

MECCANO Mechanical Loading Shovel

SPECIAL FEATURES

Powered by an E15R Electric Motor this model of a typical modern shovel excavator carries out all the essential motions of a real machine. Each movement is independently controllable from a conveniently grouped set of levers.

Shovel

(MODEL No. 10.20)

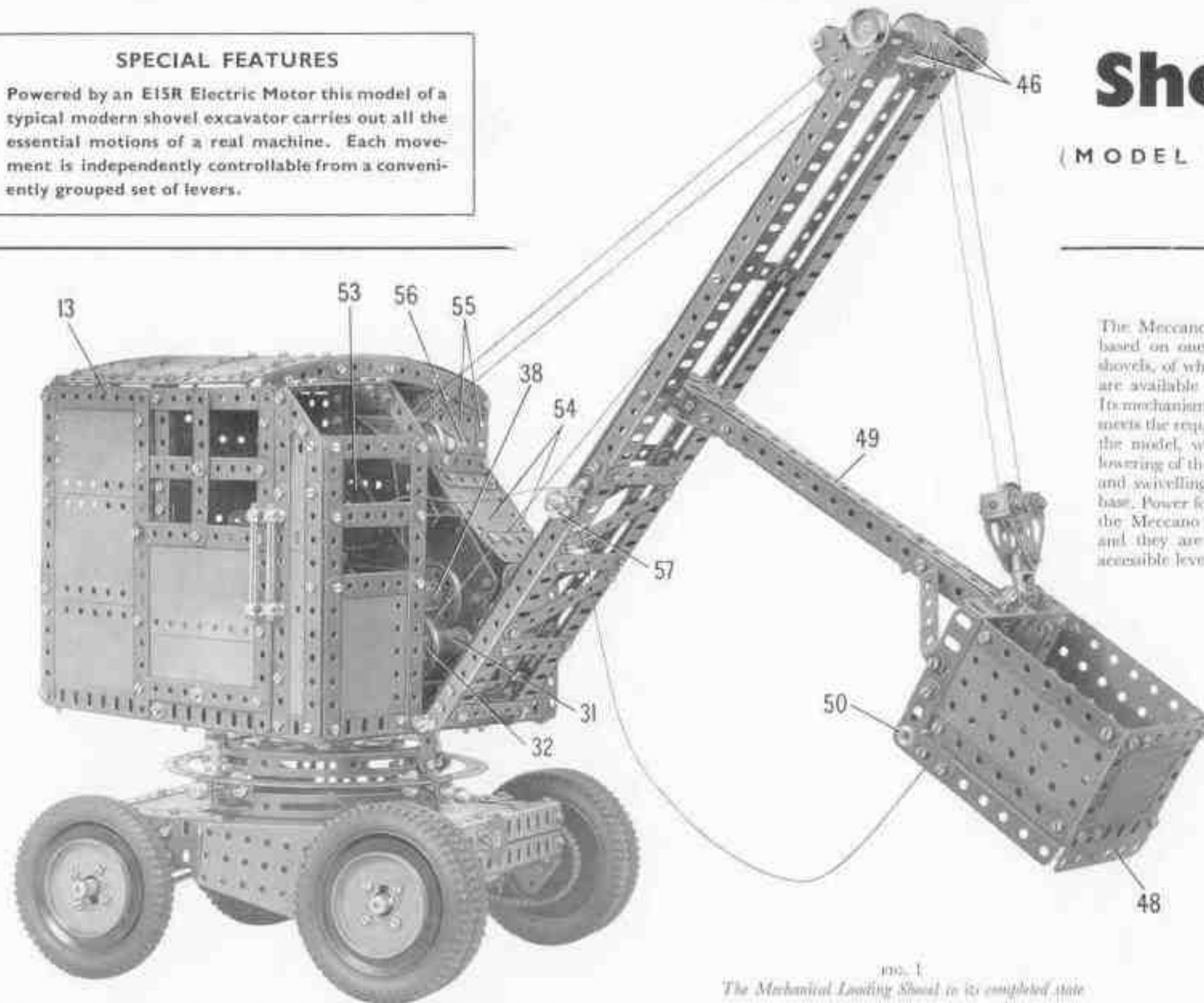

The Meccano model described in this Leaflet is based on one of the lighter types of mechanical shovels, of which many different kinds of all sizes are available to modern constructional engineers. Its mechanism, while quite simple to assemble, fully meets the requirements of the various movements of the model, which include travelling, raising and lowering of the jib, manipulation of the bucket arm and swivelling of the cab and jib on the wheeled base. Power for all these movements is provided by the Meccano E15R Electric Motor inside the cab and they are individually controlled from easily accessible levers.

Construction of the model should commence with the wheeled base or undercarriage, details of which are as follows.

The Wheeled Base (Figs. 2 and 4)

Each side-member of the base consists of two 9½" Angle Girders joined together by two 1½" Flat Girders. The side-members are connected at each end by two 5½" Angle Girders, which are bolted to Angle Brackets fixed to the 9½" Girders. A 5½" x 2½" Flexible Plate is bolted across the top of each end of the base, and the inner edges of these Plates are strengthened by 5½" Angle Girders (1) (Fig. 2).

FIG. 1

The Mechanical Loading Shovel in its completed state

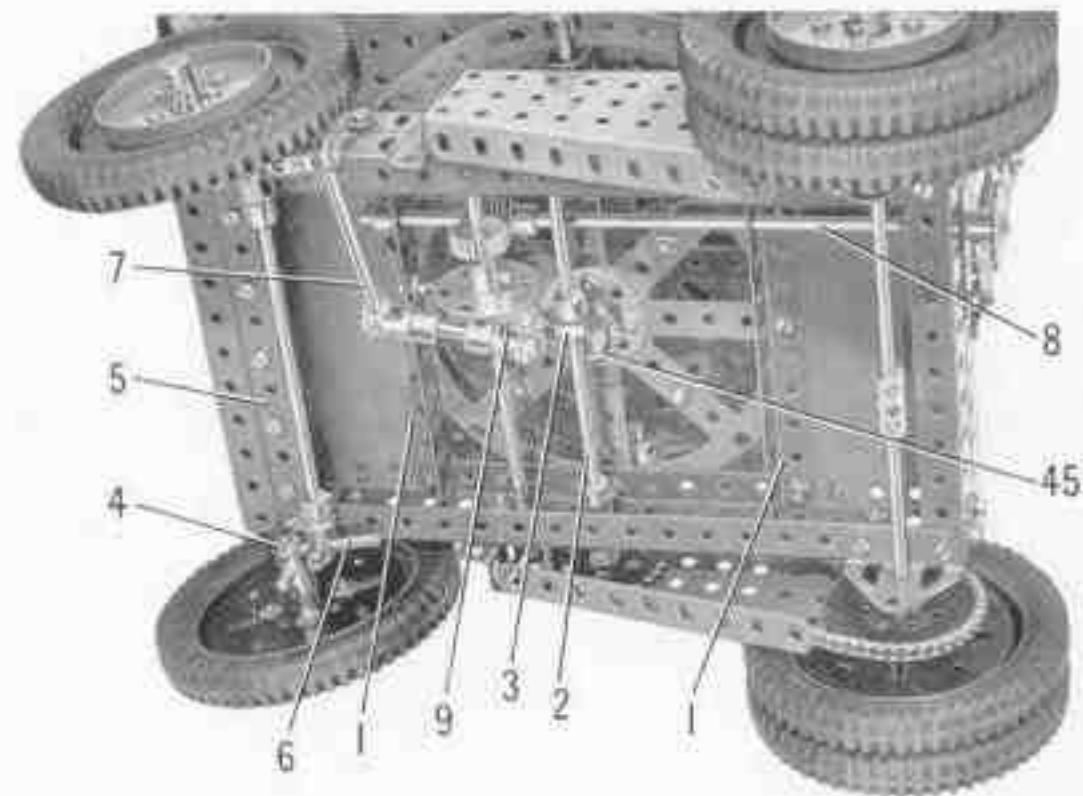

FIG. 2

The underside of the undercarriage or wheeled base, showing the steering arrangement.

The driving wheels are mounted on an axle made from a $1\frac{1}{2}$ " and a 5" Rod joined by a Coupling. This axle carries a 2" Sprocket, and is supported in Trunnions bolted to the base. The axle is held in position by the 2" Sprocket and by a $1\frac{1}{2}$ " Sprocket, and the 2" Sprocket is connected by Chain to a $1\frac{1}{2}$ " Sprocket on a Rod (2), which is held in place by a Coupling and is fitted with a $\frac{1}{2}$ " Bevel Gear (3). A guard over the Chain drive is formed by a Flanged Sector Plate. The narrow end of this Plate is attached to a $1\frac{1}{2}$ " Angle Girder by an Angle Bracket, and its wide end is supported by a Fishplate bolted to the top of the base.

Each of the steerable wheels is free to turn on a 1" Rod gripped in a Coupling (4). These Couplings are fixed on $1\frac{1}{2}$ " Rods passed through the bosses of Cranks bolted to the ends of a strip (5). This strip is made from two $4\frac{1}{2}$ " Strips overlapped five holes, and each of the Couplings (4) is spaced from it by three Washers. The $1\frac{1}{2}$ " Rods that carry the Couplings are held in place by Collars.

Each of the Couplings (4) is fitted with a $1\frac{1}{2}$ " Rod (6), and these are connected by a 5" Rod and two Swivel Bearings. One of the Rods (6) carries also a Coupling fitted with a 2" Rod (7).

A 2" Rod (8) is mounted in $2\frac{1}{2}$ " Strips that cover the slotted holes in the Girder at one end of the base, and in one of the Girders (1). A Worm on this Rod drives a $\frac{1}{2}$ " Pinion on a $6\frac{1}{2}$ " Rod held in the base side-members by Spring Clips, and the latter Rod carries a Bush Wheel (6 holes) to which a $1\frac{1}{2}$ " Strip (9) is bolted. The Strip is linked to the Rod (7) by two swivel bearings connected by a $1\frac{1}{2}$ " Rod. These swivel bearings are obtained from Universal Couplings.

Details of the Roller Bearing (Figs. 4 and 5)

A Hub Disc, with a Bush Wheel (8 holes) bolted to its centre, is fixed to the top of the wheeled base. A second Hub Disc is connected to the first by four $1\frac{1}{2}$ " \times $\frac{1}{2}$ " Double Angle Strips, and a $\frac{1}{2}$ " fixed Pulley and three $\frac{1}{2}$ " loose Pulleys (10) are located between the rims of the two Hub Discs. A $3\frac{1}{2}$ " Gear (11) is fitted with four $\frac{1}{2}$ " Bolts held in place by nuts, and each Bolt is then fixed to the upper Hub Disc by two nuts.

The Cab: Floor and Sides (Figs. 1, 3 and 8)

The framework of the floor of the cab is made from two $9\frac{1}{2}$ " Angle Girders connected at the front by a $7\frac{1}{2}$ " Angle Girder, and it is filled in by three $5\frac{1}{2}$ " \times $2\frac{1}{2}$ " Flat Plates, two $4\frac{1}{2}$ " \times $2\frac{1}{2}$ " Flat Plates and a $5\frac{1}{2}$ " \times $3\frac{1}{2}$ " Flat Plate (Fig. 3). A Circular Strip (12) is attached to the floor by two brackets, each made from a $1"$ \times $1"$ and a $\frac{1}{2}"$ \times $\frac{1}{2}"$ Angle Bracket bolted together. The bolts fixing the $\frac{1}{2}"$ \times $\frac{1}{2}"$ Angle Brackets to the Circular Strip secure also Double Brackets. At each side of the base a Coupling and five Washers are placed on a 2" Screwed Rod, between the base and the Circular Strip, and the Screwed Rod is fixed in place by nuts. Double Brackets also are fixed by the Screwed Rods as shown. The Double Brackets support 2" Rods and on these are mounted the $\frac{1}{2}"$ Pulleys (10) of the roller bearing. The loose Pulleys are held on the Rods by Collars, and the Rods are retained in the Double Brackets by two Handrail Couplings, a Collar, and one half of a Dog Clutch.

The side of the cab seen in Fig. 8 consists of a $9\frac{1}{2}"$ \times $2\frac{1}{2}"$ Strip Plate, two $5\frac{1}{2}"$ \times $2\frac{1}{2}"$ Flexible Plates, a vertical $5\frac{1}{2}"$ \times $1\frac{1}{2}"$ Flexible Plate and a $3\frac{1}{2}"$ \times $2\frac{1}{2}"$ Flexible Plate placed at an angle. The side is strengthened by Strips and built-up strips as shown.

The rear part of the side seen in Fig. 1 is filled in by three $4\frac{1}{2}"$ \times $2\frac{1}{2}"$ Flexible Plates attached to two vertical $7\frac{1}{2}"$ Strips by $\frac{1}{2}"$ Bolts, but they are spaced from the Strips by a nut on each Bolt. The top edge of the upper Plate is strengthened by a strip (13), made from two $5\frac{1}{2}"$ Strips overlapped five holes. The front part of this side consists of a $5\frac{1}{2}"$ \times $1\frac{1}{2}"$ and a $2\frac{1}{2}"$ \times $1\frac{1}{2}"$ Flexible Plate overlapped three holes and edged by Strips as shown.

Power Unit and Reduction Gearing (Figs. 6 and 7)

A Meccano E15R Electric Motor is bolted to the cab base (Fig. 7), and a $\frac{1}{2}"$ Pinion on its armature shaft

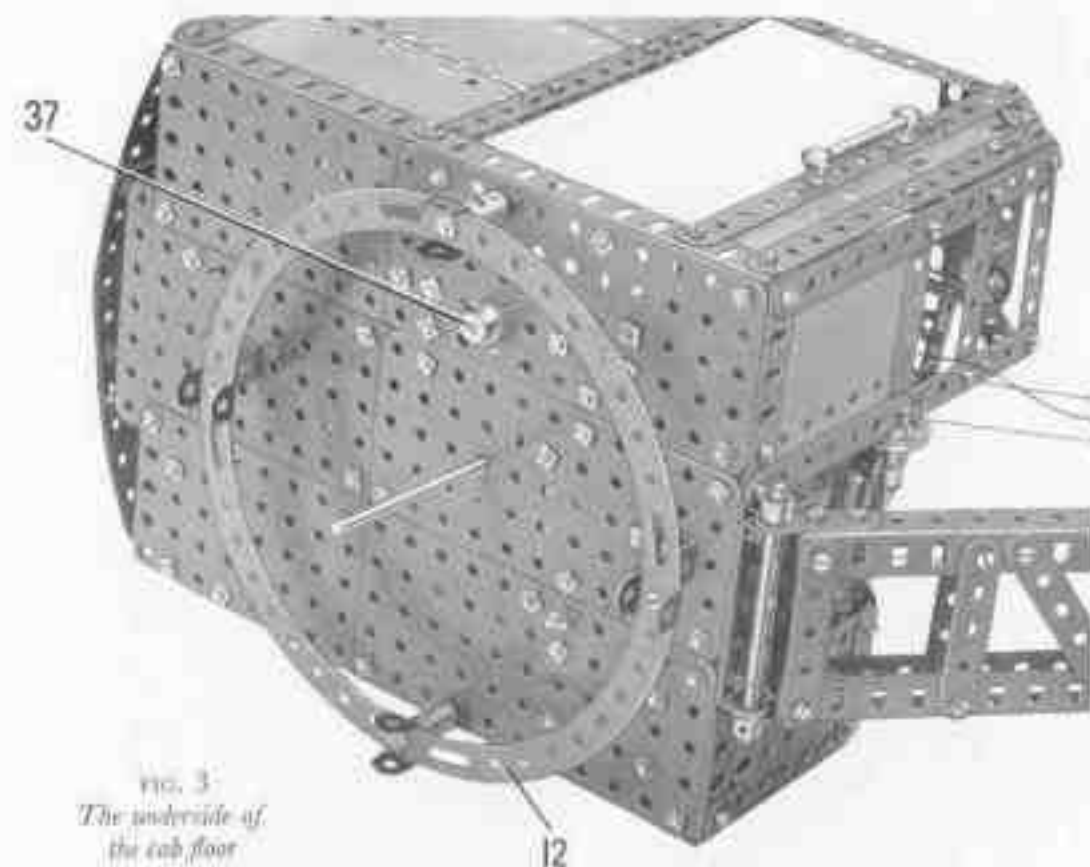
FIG. 3
The underside of the cab floor

drives a 57-tooth Gear (14) on a 3" Rod. A $\frac{1}{2}$ " Pinion on the opposite end of this Rod engages a 57-tooth Gear on a $3\frac{1}{2}$ " Rod (15). This Rod is supported in the top front holes of the Motor side-plates, and is retained in place by a $\frac{1}{2}$ " Pinion. A $\frac{1}{2}$ " Sprocket on Rod (15) is connected by Chain to a 2" Sprocket on a $4\frac{1}{2}$ " Rod (16). Rod (16) is mounted in the Motor side-plates as shown and in two $2\frac{1}{2}$ " x $1\frac{1}{2}$ " Flanged Plates (17) bolted to the base. The top flanges of the Flanged Plates are joined by a 2" Strip, and a $2\frac{1}{2}$ " x $\frac{1}{2}$ " Double Angle Strip is bolted to one of the Plates and to the Motor. The second Flanged Plate is connected to the Double Angle Strip by an Angle Bracket. A $\frac{1}{2}$ " Pinion on Rod (16) drives a 57-tooth Gear on a 2" Rod (18), which is mounted in the Flanged Plates. A $\frac{1}{2}$ " Sprocket (19) is fixed on the Rod (18).

Arrangement of the Gear-box Drive (Figs. 6, 7 and 11)

The housing for the gear-box is made by bolting two $3\frac{1}{2}$ " x $2\frac{1}{2}$ " Flanged Plates (20) (Fig. 7) and a similar Flanged Plate (21) to the floor of the cab. The Plates are spaced from the floor by a $7\frac{1}{2}$ " Strip, one end of which is seen at (22) (Fig. 11). The Flanged Plate (21) and one of the Plates (22) are each extended towards the rear by a $2\frac{1}{2}$ " x $2\frac{1}{2}$ " Flat Plate (23), which is connected to the Flanged Plate by Fishplates. A vertical $7\frac{1}{2}$ " Strip (24) (Fig. 11) is bolted to the front edge of each of the Flat Plates (23). These Strips are connected by a $2\frac{1}{2}$ " x $\frac{1}{2}$ " Double Angle Strip as shown in Fig. 6, and by a similar part bolted between the top ends of the Strips. The Strips are braced to the upper rear corners of the Flat Plates (23) by $5\frac{1}{2}$ " Angle Girders (25) (Figs. 6 and 7) which are connected by three $2\frac{1}{2}$ " Strips (see Fig. 7).

A $2\frac{1}{2}$ " x $\frac{1}{2}$ " Double Angle Strip is bolted between the Flat Plates (23) by a bolt (26) (Fig. 11) on each side, and a $2\frac{1}{2}$ " x $1\frac{1}{2}$ " Double Angle Strip is used to connect the Flat Plates to the floor of the cab. The Flanged Plates (20) (Fig. 7) are joined together by two $1\frac{1}{2}$ " Strips bolted to their upper flanges.

The gear-box has three driving or input shafts, each of which is a 2" Rod supported in the Flanged Plates (20) and fitted with a 1" Sprocket and a $\frac{1}{2}$ " Pinion. One of these shafts is indicated at (27) (Figs. 6 and 7), and it is mounted in the next to top holes of the rear edges of the Flanged Plates (20). This shaft is used to engage the forward drive for the travelling movement and the lifting drive to the luffing drum. The second driving shaft is seen at (28) (Fig. 7). This shaft is mounted in the centre holes of the Flanged Plates (20), and it will be seen that its $\frac{1}{2}$ " Pinion is fixed towards the centre of the shaft, so that a gap sufficient to accommodate a 50-tooth Gear is left between the Pinions on the shafts (27) and (28). The shaft (28) is used to provide the reverse drives for all four movements of the gear-box, and it is located in its bearings by a collar formed by the other half of the Dog Clutch. Unfortunately the third driving shaft cannot be seen in our illustrations, but

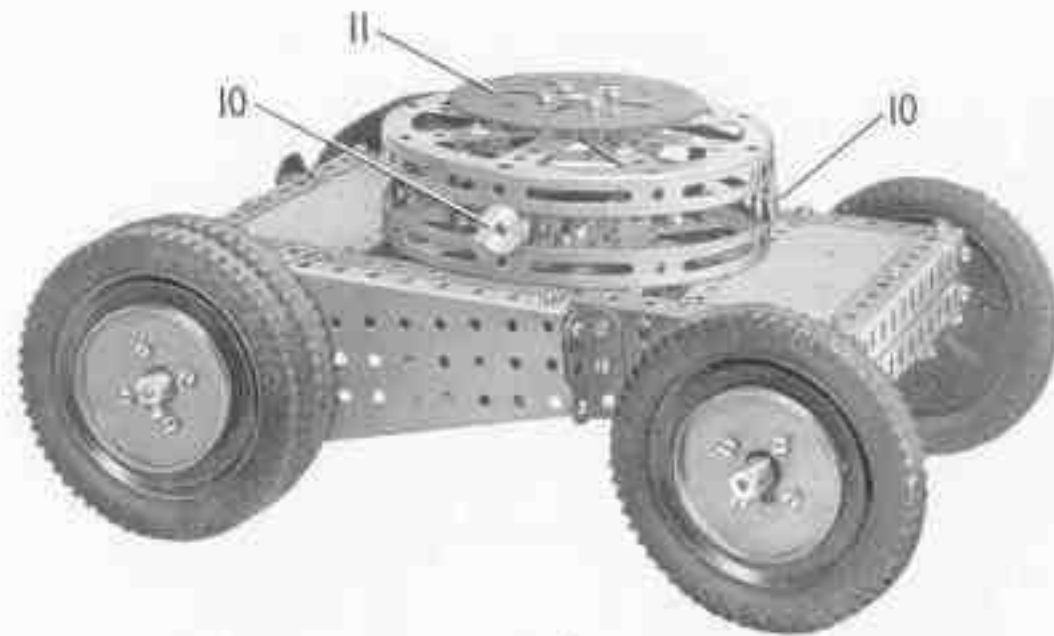

FIG. 4

A general view of the wheeled base or undercarriage.

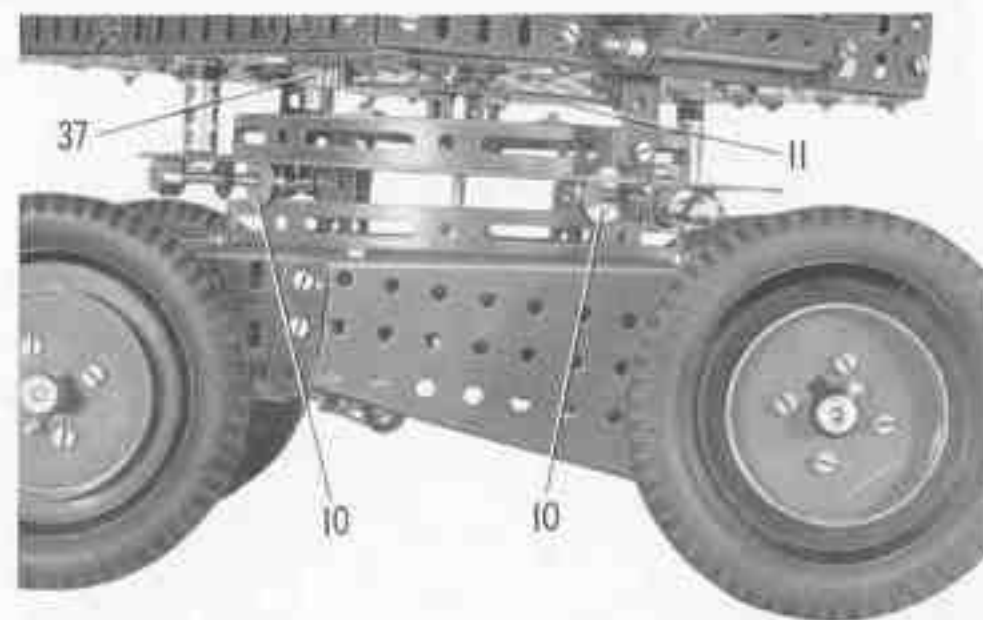

FIG. 5 A close-up of the roller bearing unit mounted on the wheeled base

the arrangement of its Sprocket and Pinion is the same as for the shaft (27). This third shaft, however, is mounted in the next to bottom holes along the front edges of the Flanged Plates (20), and it provides the drive to the hoisting movement of the bucket, and also to the cab slewing motion in one direction. To simplify the description of the drives from the third shaft it will be referred to as shaft (29), but of course this number does not appear in the illustrations as the shaft cannot be seen.

The drive to the gear-box is by Chain from the Sprocket (19) (Fig. 7). The Chain passes over and round the Sprocket on shaft (27), under and round the Sprocket on shaft (28), and over and round the Sprocket on the hidden third shaft (29). This arrangement ensures that shaft (28) turns in the opposite direction to the shafts (27) and (29).

The Bucket Arm and the Slewing Motion Drives (Figs. 1, 5 and 11)

The shaft that carries the bucket arm hoisting drum is a 5" Rod (30) (Fig. 11), mounted in the Flanged Plates (20) and (21). The drum (seen at 31 Fig. 1) is a Sleeve Piece pressed inside the teeth of a $\frac{1}{2}$ " Contrate and fixed on the Rod between this Contrate and a $1\frac{1}{2}$ " Pulley (32). A length of Cord tied to the $7\frac{1}{2}$ " Angle Girder at the front of the cab is passed round the Pulley (32) and is fastened to a Driving Band. The Driving Band is stretched slightly and is placed over a $3\frac{1}{2}$ " Rod passed through holes in the lower edges of the Flanged Plate (21) and one of the Flanged Plates (20). This arrangement provides a constant braking effect on the winding drum shaft (30).

The drum shaft (30) carries a 50-tooth Gear arranged so that it can be meshed with the Pinion on the shaft (28) or the Pinion on the hidden shaft (29). The Gear is engaged with the appropriate Pinion by sliding the Rod (30) by means of a lever (33) (Fig. 11). This lever is a $2\frac{1}{2}$ " Rod fitted in a Rod and Strip Connector lock-nutted to a Double Bracket bolted to the base of the cab. The lever engages between two Collars on the drum shaft (30).

The drive to the slewing motion is engaged by meshing a 50-tooth Gear on a $6\frac{1}{2}$ " Rod (34) (Fig. 11) with either of the Pinions on shafts (28) and (29), in the same way as the drive to the drum shaft (30) already described. The movement of Rod (34) is controlled by a lever (35), which is a $1\frac{1}{2}$ " Rod held in a Rod and Strip Connector that is bolted tightly to a $1\frac{1}{2}$ " Strip. This Strip is lock-nutted to the other lug of the Double Bracket that supports the lever (33). A $\frac{1}{2}$ " Bolt fixed in the $1\frac{1}{2}$ " Strip by two nuts engages between a Collar and a $\frac{1}{2}$ " Pinion (36) on Rod (34). The outer end of the Rod (34) is supported by a $1"$ x $1"$ Angle Bracket, which is spaced from the floor of the cab by a Fishplate.

Pinion (36) engages a $\frac{1}{2}$ " Contrate on a $3\frac{1}{2}$ " Rod, which is supported in the lugs of a $2\frac{1}{2}$ " x $1"$ Double Angle Strip spaced from the floor of the cab by a $2\frac{1}{2}$ " Strip. Each lug is strengthened by a $1"$ x $\frac{1}{2}"$ Angle Bracket bolted to the lug and to the floor. A $\frac{1}{2}"$ Bevel Gear on the $3\frac{1}{2}"$ Rod drives a similar

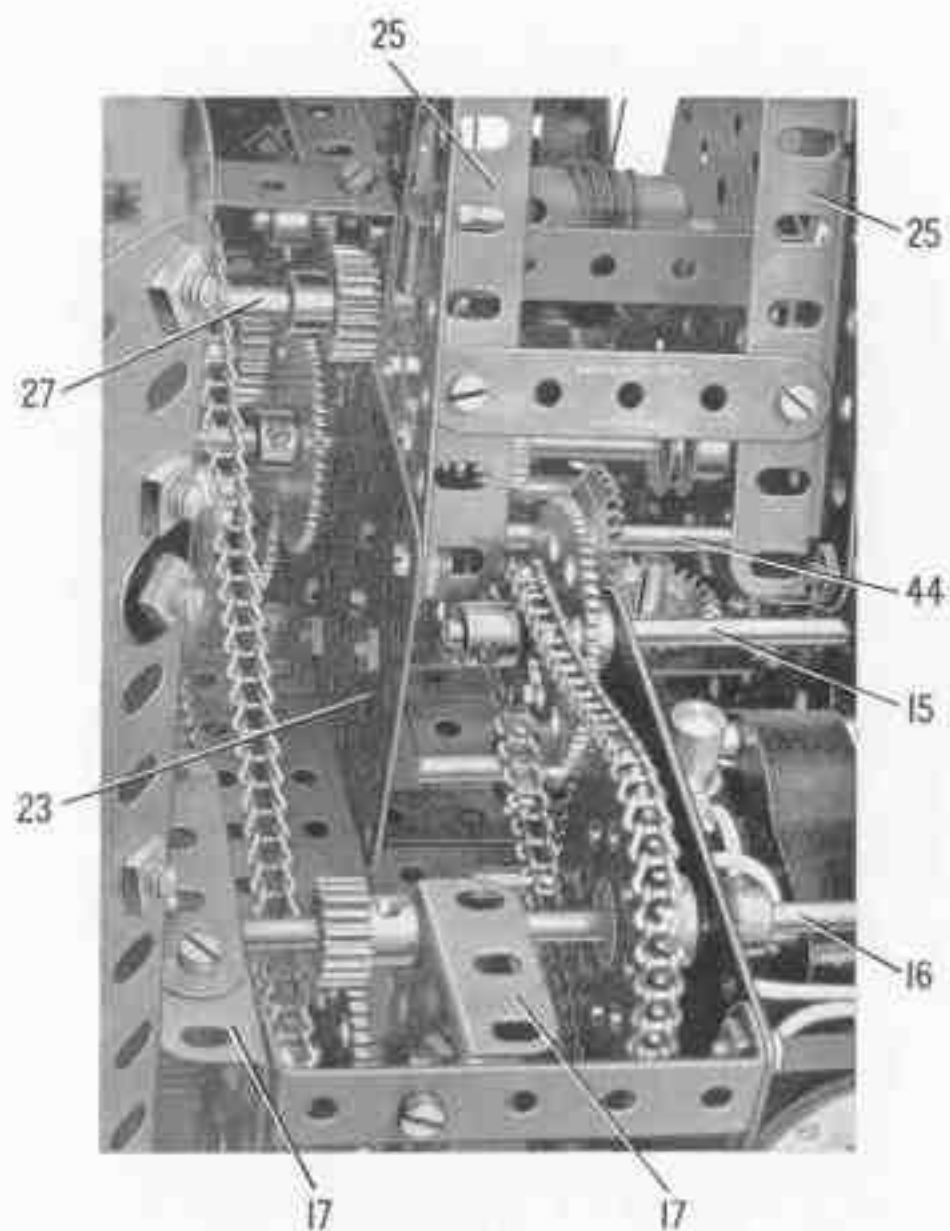

FIG. 6

A close-up of the Main reduction gearing and the gear-bus housed in the cab

Bevel Gear on a 1" Rod passed through the floor of the cab. A $\frac{1}{2}$ " Pinion (37) (Fig. 5) on the lower end of the 1" Rod engages the Gear (11) of the roller bearing.

Drives to the Luffing and Travelling Movements (Figs. 1, 2, 4, 5, 6, 7 and 11)

The luffing drum, which is seen at (38) (Fig. 1), consists of a Sleeve Piece fitted with a Chimney Adaptor at one end and connected at its other end to a $1\frac{1}{2}$ " Pulley by an Angle Bracket. The Pulley is fixed on a 5" Rod (39) (Fig. 11), and is provided with a Cord brake in the same way as the Pulley (32) (Fig. 1). Rod (39) carries a 50-tooth Gear that can be meshed with the Pinions on shafts (27) and (28), as already described in connection with the drive to Rod (30). The movement of Rod (39) is controlled by a lever (40) (Fig. 11), which is a 1" Rod in a Rod and Strip Connector that is bolted tightly to a $1\frac{1}{2}$ " Strip. The bolt head engages between two Collars on Rod (39), and the Strip is lock-welded to an Angle Bracket bolted to the Flanged Plate (21).

The drive to the travelling motion is engaged by sliding a 5" Rod (41) (Fig. 11) to bring a 50-tooth Gear into mesh with the Pinion on either shaft (27) or shaft (28) (Fig. 7). The sliding motion is controlled by a lever (42) (Fig. 11), which is a $2\frac{1}{2}$ " Rod in a Rod and Strip Connector. The lever engages between two Collars on Rod (41), and the Rod and Strip Connector is lock-welded to an Angle Bracket bolted to the floor of the cab. Rod (41) is fitted with a $\frac{1}{2}$ " diameter, $\frac{1}{4}$ " face Pinion (43), and this drives a 57-tooth Gear on a $2\frac{1}{2}$ " Rod (44) (Figs. 6 and 7). A $\frac{1}{2}$ " Bevel Gear on Rod (44) engages a similar Bevel Gear on a vertical Rod supported in the floor of the cab and in the Double Angle Strip held by the bolts (26). The vertical Rod passes freely through the Gear (11) (Figs. 4 and 5) and the centre of the roller bearing unit, and at its lower end it is fitted with a $\frac{1}{2}$ " Bevel Gear (45) (Fig. 2) that drives the Bevel Gear (3) of the wheeled base.

FIG. 7
A view of the
general layout
inside the cab

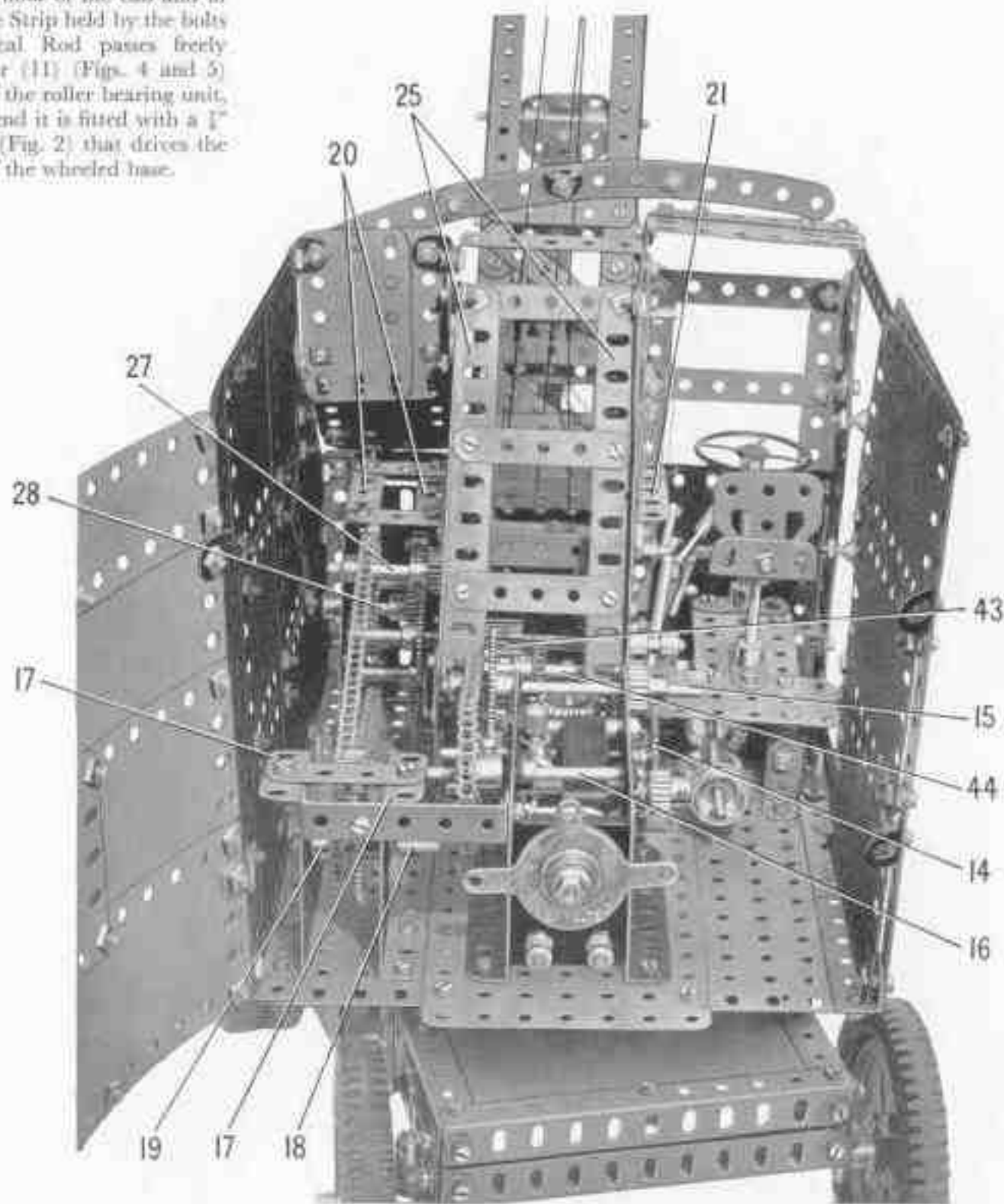

Details of the Jib (Figs. 1 and 8)

Two $1\frac{1}{2}$ " Angle Girders are connected together by $2\frac{1}{2}$ " Strips as shown (Fig. 1), and are braced by diagonal 3" Strips. Two $1\frac{1}{2}$ " Strips on each side are overlapped 13 holes, and are then attached to the Girder by Angle Brackets. The $1\frac{1}{2}$ " Strips are linked and braced by $2\frac{1}{2}$ " and 3" Strips in the same way as the Angle Girders. The lower end of each Angle Girder is extended one hole by a $\frac{1}{2}$ " Strip. These Strips are mounted on a $\frac{3}{4}$ " Rod supported in a $2\frac{1}{2}$ " \times $\frac{1}{2}$ " Double Angle Strip bolted to the front of the cab. A $\frac{3}{4}$ " Rod is mounted at the top of the jib, and on it are placed two 1" Pulleys (46).

Two $\frac{1}{2}$ " Corner Brackets are bolted to the top of the jib, and two $2\frac{1}{2}$ " \times $1\frac{1}{2}$ " Double Angle Strips are *lock-welded* to them by 1" Bolts. A Flatplate is bolted to the centre of each Double Angle Strip, and a 1" loose Pulley (47) (Fig. 8) is freely mounted on a Pivot Bolt passed through the Flatplates and fixed by its nuts. The Pulley is spaced centrally on the Pivot Bolt by Washers.

The Bucket and Its Supporting Arm (Figs. 1 and 8)

The sides of the bucket are $3\frac{1}{2}$ " \times $2\frac{1}{2}$ " Flanged Plates, connected at each end by two $2\frac{1}{2}$ " \times $2\frac{1}{2}$ " Flexible Plates overlapped four holes. The inner end Plates are strengthened along their lower edges by a 3" Strip, and the outer end Plates by a 3" Strip and a 3" Flat Girder (48) (Fig. 1). The inner end of the bucket is edged by two $2\frac{1}{2}$ " Angle Girders and a 3" Angle Girder.

The bucket arm consists of four 9 $\frac{1}{2}$ " Strips. The two side Strips are attached to the bucket by Angle Brackets, and are tied to its sides by 3" Strips shaped as shown. Each of the side 9 $\frac{1}{2}$ " Strips is fitted at its outer end with a Crank, and these are fixed on a 3" Rod mounted in the jib. The arm is made into a box-section girder by two further 9 $\frac{1}{2}$ " Strips (49), each of which is fitted at its inner end with a Flat Trunnion. One of the Strips (49) is attached to the bucket by an Angle Bracket, and the two Strips are then held against the edges of the side 9 $\frac{1}{2}$ " Strips by 1" Bolts. These Bolts are passed through the Strips (49).

The bucket has a hinged flap (see Fig. 8) which consists of a $3\frac{1}{2}$ " Angle Girder and a $3\frac{1}{2}$ " Flat Girder on each side, connected by two 2" Strips bolted to the Flat Girders. Two $3\frac{1}{2}$ " Strips are fixed to the 2" Strips. A Bell Crank (50) is bolted to each $3\frac{1}{2}$ " Angle Girder, and is *lock-welded* to one of the $2\frac{1}{2}$ " Angle Girders that edge the inner end of the bucket.

The hinged flap can be released to discharge the contents of the bucket by opening a catch (51) (Fig. 8). This is a $\frac{3}{4}$ " Rod fixed with an End Bearing, and it slides freely in a Double Bracket and an Angle Bracket bolted to the back of the hinged flap. A Collar restricts the sliding movement of the Rod. When the flap is closed the lower end of the Rod passes through a hole in the Flat Girder (48).

A pivoted pulley block is fitted to the bucket as shown in Fig. 1. It is formed by two Flat Trunnions connected by Double Brackets, with a 1" loose Pulley (52) (Fig. 8) freely mounted on a Pivot Bolt. Bolts passed through the holes at the pointed ends of the Flat Trunnions are screwed into the boss of a small Fork Piece. The Fork Piece pivots on a 1" Screwed Rod, which is fixed by nuts in Angle Brackets bolted to the 3" Angle Girder.

The Cab: Front, Roof and Back (Figs. 1, 8 and 11)

The front of the control cabin is made from a $3\frac{1}{2}$ " \times $2\frac{1}{2}$ " Flexible Plate and Strips as shown in Fig. 1. The side window is formed by a $3\frac{1}{2}$ " Strip at the front, connected to the upper end of one of the Strips (24) (Fig. 11) by two 2" Strips. A $\frac{1}{2}$ " Strip (53) is bolted diagonally across the window and is connected to the $3\frac{1}{2}$ " Strip by a 2" Strip, placed horizontally. A $2\frac{1}{2}$ " \times $\frac{1}{2}$ " Double Angle Strip is bolted between the Strip (53) and between a similar Strip on the opposite side. The roof over the cabin is made from two $2\frac{1}{2}$ " \times $1\frac{1}{2}$ " Flexible Plates supported by Angle Brackets.

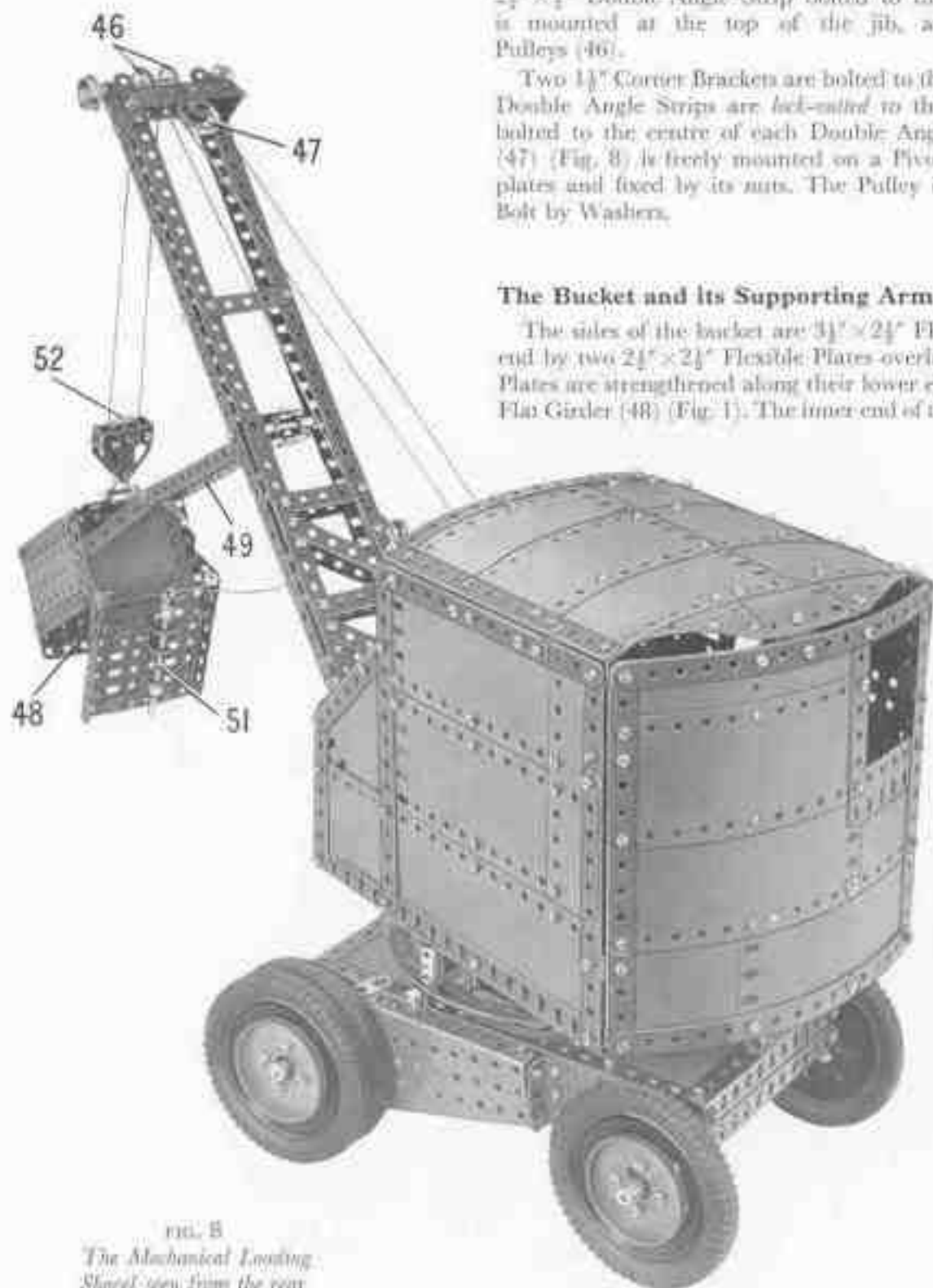

FIG. 8
The Mechanical Lifting
Sheet, seen from the rear



FIG. 9
The driver's seat removed from the cab

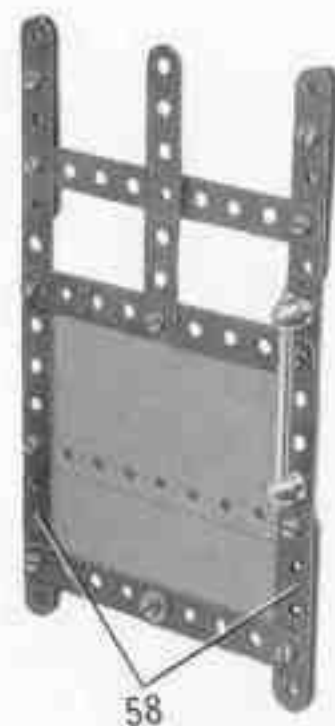

FIG. 10
Detail of the sliding
door of the cab

The lower part of the front opposite to the control cabin consists of two vertical $3\frac{1}{2}$ " Strips connected at their upper ends by a 2" Strip, and joined to the side of the cab by an Angle Bracket. A $2\frac{1}{2}$ " x $1\frac{1}{2}$ " Flexible Plate is fixed to one of the $3\frac{1}{2}$ " Strips. Two $2\frac{1}{2}$ " x $1\frac{1}{2}$ " Flexible Plates (54) (Fig. 1) are connected by a 2" Flat Girder and a 2" Strip, and this assembly is attached to the lower part of the front by an Obtuse Angle Bracket. Two further $2\frac{1}{2}$ " x $1\frac{1}{2}$ " Flexible Plates (55) are connected to the side of the cab and to one of the Strips (24) (Fig. 11) by Angle Brackets, and are joined to the Plates (54) by two Obtuse Angle Brackets. The front is completed by two $5\frac{1}{2}$ " Curved Strips overlapped seven holes.

The roof is formed by $4\frac{1}{2}$ " x $2\frac{1}{2}$ " Flexible Plates, two $2\frac{1}{2}$ " x $1\frac{1}{2}$ " Flexible Plates and two $2\frac{1}{2}$ " x $1\frac{1}{2}$ " Triangular Flexible Plates, arranged as shown in Fig. 8 and edged by Strips. The joints between the Plates are strengthened on the inside by pairs of $5\frac{1}{2}$ " Strips overlapped six holes each. The roof is attached to the sides of the cab by Obtuse Angle Brackets, and to the Curved Strips of the front by an Angle Bracket.

The construction of the back is shown in Fig. 8. It is attached to one side by two Hinges, and bolted to Obtuse Angle Brackets fixed to the other side.

Arrangement of the Cords (Figs. 1 and 8)

The luffing Cord is tied to the drum (38) (Fig. 1), is passed over a 1" Pulley on a Rod (56) and round the 1" loose Pulley (47) (Fig. 11). It passes over a second 1" Pulley on Rod (56) (Fig. 1) and is tied to the $2\frac{1}{2}$ " x $1\frac{1}{2}$ " Double Angle Strip that is bolted to the Strip (53). The

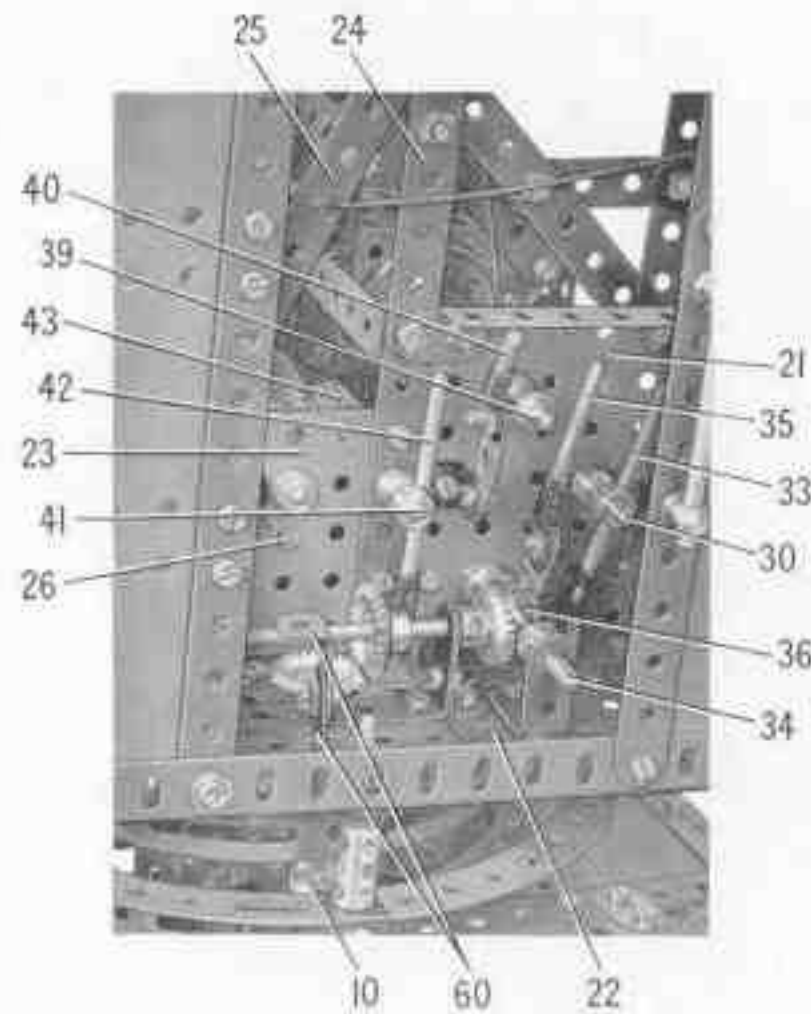

FIG. 11

The united levers are grouped together, and access to them is gained by sliding the movable cab door

Rod (56) is mounted in a $2\frac{1}{2}$ " x $1\frac{1}{2}$ " Double Angle Strip bolted to the upper ends of the Girders (25) (Fig. 7).

The Cord for controlling the bucket is fastened to the drum (31), is taken over one of the Pulleys (46) (Fig. 1), round Pulley (52) (Fig. 8) of the bucket, and is passed over the second Pulley (46). The Cord is tied finally to one of the bearing Strips of the jib.

A length of Cord tied to the End Bearing of the bucket discharge catch is taken over a $\frac{1}{2}$ " loose Pulley (57) (Fig. 1) and is fastened inside the cab. Pulley (57) is free to turn on a $\frac{1}{2}$ " Bolt, which is fixed by a nut in a Threaded Crank bolted to the jib. The Cord is retained in the groove of the Pulley by a Fishplate bolted to an Angle Bracket, which is fixed to the jib.

The Cab: Sliding Door and the Driver's Seat

The sliding door of the cab is made by bolting two $4\frac{1}{2}$ " x $2\frac{1}{2}$ " Flexible Plates between two $7\frac{1}{2}$ " Strips (58) (Fig. 10). The window frame is made from Strips as shown. A $2\frac{1}{2}$ " Strip is attached to each end of each Strip (58) by two 1" Bolts, but is spaced from the Strip (58) by a nut and a Washer on each Bolt. The lower ends of the Strips (58) and their $2\frac{1}{2}$ " Strips fit over the Angle Girder that edges the floor of the cab, and the upper ends of the Strips slide freely over the strip (13) (Fig. 1).

The driver's seat is seen removed from the cab in Fig. 9. It is connected to the side of the cab by a $1\frac{1}{2}$ " x $1\frac{1}{2}$ " Angle Bracket (59), and is supported by two $1\frac{1}{2}$ " x $1\frac{1}{2}$ " Angle Brackets (60) (Fig. 11) bolted together as shown.

Parts Required to Build the Meccano Mechanical Loading Shovel

4 of No. 1	2 of No. 9b	1 of No. 15b	1 of No. 21	85 of No. 38	3 of No. 62b	2 of No. 103e	4 of No. 137	4 of No. 190
4 " " 14	1 " " 9c	6 " " 16	1 " " 24b	1 " " 40	7 " " 63	1 " " 103g	2 " " 140	2 " " 190a
6 " " 16	2 " " 9d	6 " " 16a	4 " " 25	3 " " 46	3 " " 70	4 " " 103h	6 " " 142b	11 " " 191
23 " " 2	2 " " 9f	4 " " 16b	6 " " 26	1 " " 47	2 " " 72	6 " " 111	1 " " 144	9 " " 192
11 " " 2a	14 " " 10	8 " " 17	1 " " 26b	4 " " 48	2 " " 73	1 " " 111a	1 " " 145	1 " " 195
16 " " 3	9 " " 11	6 " " 18a	4 " " 27	8 " " 48a	2 " " 81	14 " " 111c	2 " " 147b	4 " " 212
12 " " 4	48 " " 12	4 " " 18b	4 " " 27a	2 " " 51	1 " " 82	2 " " 114	2 " " 163	2 " " 221
34 " " 5	4 " " 12a	6 " " 19b	1 " " 27b	1 " " 52a	2 " " 89	2 " " 118	2 " " 164	
11 " " 6	5 " " 12b	3 " " 20b	2 " " 29	5 " " 53	1 " " 94	2 " " 126	2 " " 165	
9 " " 6a	9 " " 12c	2 " " 21	6 " " 30	2 " " 53a	2 " " 95	6 " " 126a	1 " " 166	
2 " " 7a	1 " " 13a	4 " " 22	1 " " 32	2 " " 54	2 " " 95a	2 " " 128	1 " " 185	1 E15R
6 " " 8a	3 " " 14	2 " " 22a	4 " " 35	24 " " 59	4 " " 96	2 " " 133	2 " " 186	Electric Motor
1 " " 8b	4 " " 15	4 " " 23	539 " " 57a	4 " " 62	2 " " 96a	4 " " 156	10 " " 188	(not included
8 " " 9	4 " " 15a	2 " " 23a	474 " " 57b	1 " " 62a	2 " " 103d	2 " " 136a	5 " " 189	in Outfit)