

# MECCANO

## Road Surfacing Machine

(MODEL No. 10.19)

### SPECIAL FEATURES

This Model is operated by a Meccano E15R type 15-20-volt Electric Motor that provides power for four independently controlled mechanisms and movements, viz., a drive to the travelling wheels, a conveyor that carries the surfacing material to the grader and distributor head, a feed arrangement to spread the material as the machine travels along and a tamping device operated by eccentrics to consolidate the road surface. Each movement is controlled by a group of levers arranged conveniently close to the driver's seat.

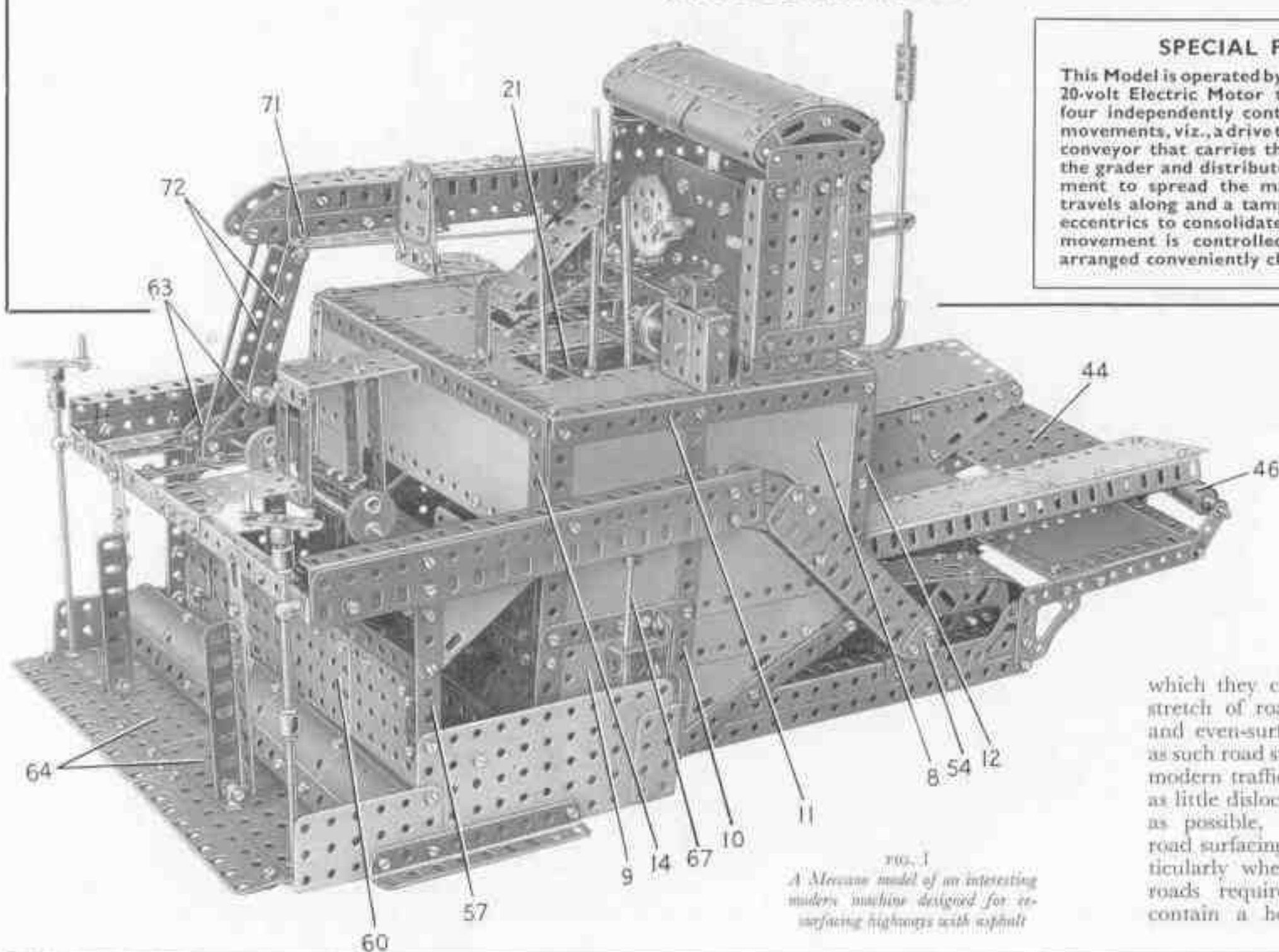

FIG. 1  
A Meccano model of an interesting modern machine designed for resurfacing highways with asphalt

We are all familiar with gangs of roadmakers, with their picks and shovels, tar boilers and steam or diesel rollers, busy at work re-making our highways, and few of us perhaps have not paused to watch them at work and to marvel at the comparative rapidity with which they convert a badly pitted and rough stretch of roadway into a beautifully graded and even-surfaced highway. Fast and efficient as such road surfacing methods can be, however, modern traffic conditions in some areas call for as little dislocation in the use of a thoroughfare as possible, and nowadays therefore special road surfacing machines are often used, particularly when very long stretches of asphalt roads require resurfacing. These machines contain a hopper into which the prepared

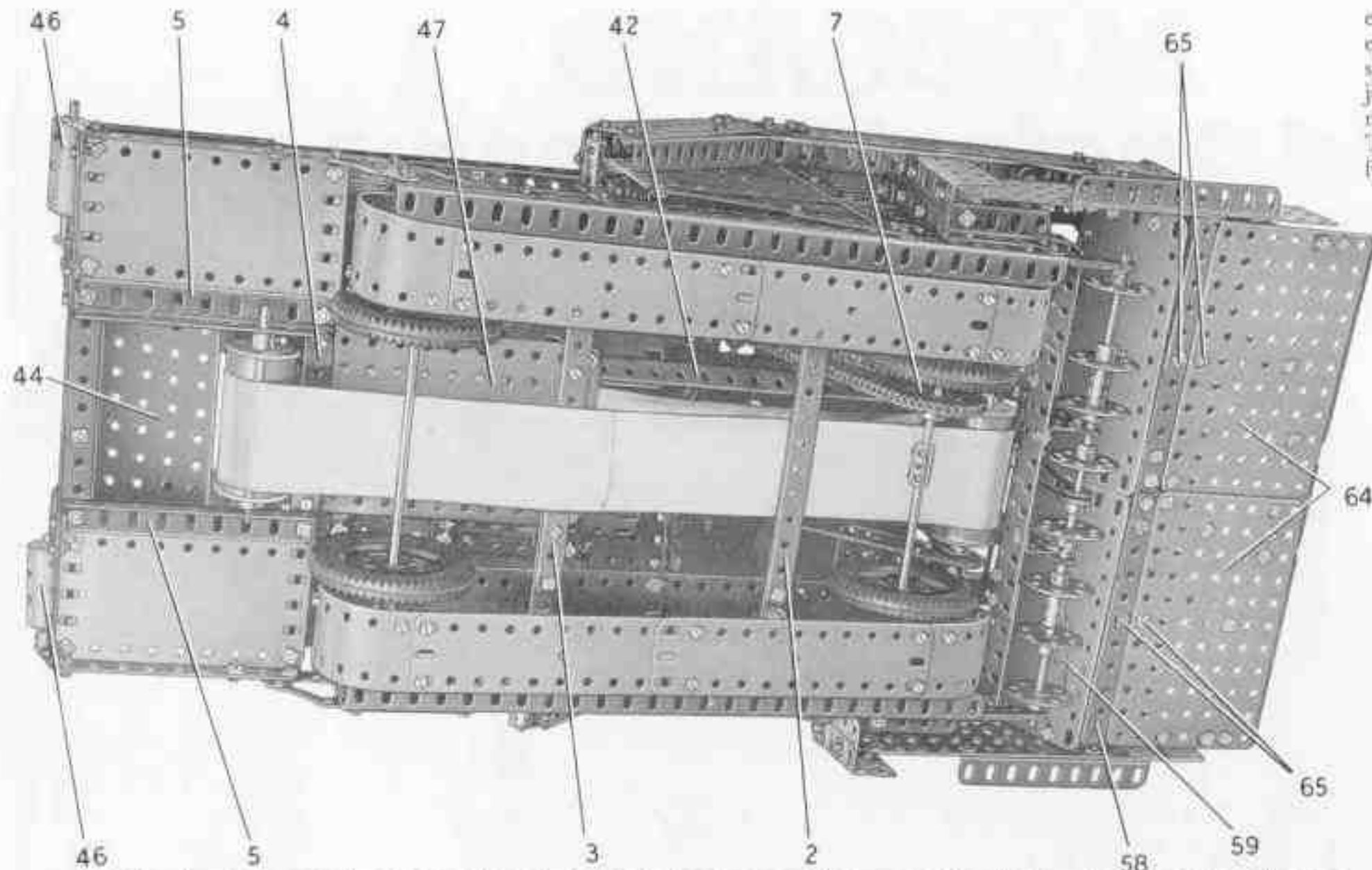

FIG. 2 An underneath view of the Road Surfacing Machine showing details of the main frame and the conveyor. As the asphalt leaves the conveyor it is distributed over the road surface by the column of revolving Bush Wheels seen at the rear end of the machine

asphalt is loaded. The hopper feeds a conveyor which carries the material under powerful heaters that make it sufficiently plastic for distribution, and a distributing device spreads it evenly over the road surface as the machine travels slowly along. There is also a tamping device that consolidates the material and an adjustable grading plate that gives the correct camber to the road surface.

The Meccano model reproduces most of the features of an actual machine of this kind, but of course the heating plant has had to be omitted for obvious reasons.

#### Construction of the Main Frame (Figs. 2 and 3)

Each side of the frame consists of two 12½" Angle Girders connected at one

end by a 7½" Strip (1) and at the other end by two Corner Gussets, arranged as shown in Fig. 3. The side members are joined together by three built-up strips numbered (2), (3) and (4) in Fig. 2. The strips (2) and (3) are each made from two 7½" Strips overlapped 11 holes, and strip (4) consists of two 5½" Strips overlapped three holes. The strip (4) is bolted to 4½" Angle Girders fixed to the Corner Gussets, and these Girders support also 4½" x 2½" Flexible Plates. The outer ends of the 4½" Angle Girders are connected by two 5½" Strips overlapped three holes, and two 4½" Angle Girders (5) are bolted between these Strips and the strip (4).

A 12½" Strip (6) (Fig. 3) on each side is attached to the strip (2) by an Angle Bracket, and is connected to the main side member by two 1½" x ½" Double Angle Strips, one of which is fixed below the strip (3) and the other is positioned in the third hole behind the strip (2). A Face Plate is bolted to each end of each of the Strips (6), and these support in their bosses the axes that carry the travelling wheels. These wheels are 2" Pulleys with Tyres. Two of them are fixed on an 8" Rod that is held in position by Collars. The other two are mounted on an

axle formed by a 5" Rod and a 4½" Rod joined by a Coupling and fitted with a 2" Sprocket (7) (Fig. 2).

The dummy creeper tracks are each made from six 5½" x 1½" Flexible Plates bolted together and attached by Angle Brackets to the Face Plates. The inner edge of the lower side of each track is strengthened by two 5½" Strips.

#### Assembly of the Mechanism Housing (Figs. 1, 3, 4 and 7)

Each side of the housing consists of two 4½" x 2½" Flexible Plates, two 3½" x 2½" Flexible Plates, a 5½" x 2½" Flexible Plate (8), a 2½" x 2½" Flexible Plate (9) and a 3½" x 2" Triangular Flexible Plate. These parts are arranged as shown in Figs. 1 and 3, and are strengthened by the Strip (1), a 7½" Strip (10), two



horizontal  $3\frac{1}{2}$ " Strips, a  $7\frac{1}{2}$ " Angle Girder (11), a  $5\frac{1}{2}$ " Angle Girder (12) and a built-up strip. The built-up strip is made from a 3" and a  $2\frac{1}{2}$ " Strip.

The front end of the housing is made by bolting a  $9\frac{1}{2}$ " $\times$  $2\frac{1}{2}$ " Strip Plate between the Girders (12). The Strip Plate is edged by a  $9\frac{1}{2}$ " Strip and a  $9\frac{1}{2}$ " Flat Girder, and is extended downward at each side by a  $2\frac{1}{2}$ " $\times$  $1\frac{1}{2}$ " Flexible Plate strengthened by a 2" Angle Girder (13). The rear of the housing (Fig. 1) consists of a  $9\frac{1}{2}$ " $\times$  $2\frac{1}{2}$ " Strip Plate bolted to a  $9\frac{1}{2}$ " Angle Girder fixed between the Girders (11) of the sides. The Strip Plate is extended downward at each side by a  $2\frac{1}{2}$ " $\times$  $2\frac{1}{2}$ " Flexible Plate, and these are edged by  $4\frac{1}{2}$ " Strips (14). The lower edges of the  $2\frac{1}{2}$ " $\times$  $2\frac{1}{2}$ " Flexible Plates are strengthened by a  $9\frac{1}{2}$ " Strip (15) (Fig. 10), which is connected to the Strips (1) by Angle Brackets. A built-up strip (16), made from two  $5\frac{1}{2}$ " Strips, also is attached to the Strips (1) by Angle Brackets, and a built-up flat girder (17), made from a  $5\frac{1}{2}$ " and two 3" Flat Girders, is supported by  $1$ " $\times$  $\frac{1}{2}$ " Angle Brackets bolted to the Strips (1).

A  $9\frac{1}{2}$ " Angle Girder (18) (Fig. 4) is bolted across the top of the housing and to it are fixed a  $5\frac{1}{2}$ " $\times$  $3\frac{1}{2}$ " Flat Plate (19) and a  $4\frac{1}{2}$ " $\times$  $2\frac{1}{2}$ " Flat Plate (20). The top of the housing is completed by two  $4\frac{1}{2}$ " $\times$  $2\frac{1}{2}$ " Flexible Plates, a  $3\frac{1}{2}$ " $\times$  $2\frac{1}{2}$ " Flexible Plate and two  $2\frac{1}{2}$ " $\times$  $1\frac{1}{2}$ " Flexible Plates, as shown in Fig. 7. A  $5\frac{1}{2}$ " Strip (21) (Fig. 1) is bolted to the top.

#### The Power Unit and Reduction Gearing (Figs. 3 and 6)

An E15R Electric Motor is bolted by its flanges to two  $5\frac{1}{2}$ " Angle Girders, which are connected at their ends by  $2\frac{1}{2}$ " Angle Girders (22) (Fig. 6). A  $3\frac{1}{2}$ " $\times$  $2\frac{1}{2}$ " Flanged Plate is fixed to one of the Girders (22) and is extended upward by a  $2\frac{1}{2}$ " Flat Girder. Two  $3\frac{1}{2}$ " Angle Girders are bolted to the second Girder (22), and are connected by a  $2\frac{1}{2}$ " $\times$  $2\frac{1}{2}$ " Flat Plate, a  $2\frac{1}{2}$ " Strip and a  $2\frac{1}{2}$ " Flat Girder. A vertical  $3\frac{1}{2}$ " Strip is bolted to the Flat Plate. The engine cover is formed by a  $5\frac{1}{2}$ " $\times$  $2\frac{1}{2}$ " Flexible Plate fitted at each side with three U-section Curved Plates, whose lower edges are connected by  $5\frac{1}{2}$ " Strips. Two curved  $3\frac{1}{2}$ " Strips are bolted to the Plates as shown and a 3" Stepped Curved Strip is attached to each end by an Angle Bracket. The cover is bolted at one end to the

top flange of the Flanged Plate. At the other end a  $1\frac{1}{2}$ " Strip is bolted between the corners of the "U"-section Plates and is connected to the radiator by an Angle Bracket.

A Trunnion is fixed by its flange to each of the Girders (22), and the Trunnions are bolted to  $2\frac{1}{2}$ " Angle Girders (23) (Figs. 3 and 6) attached to the Flat Plate (19). The exhaust pipe is formed by a Dog Clutch and two Collars on a  $6\frac{1}{2}$ " Rod, which is held by a Spring Clip in a Single Bent Strip bolted to the radiator. A Spring is passed over the lower end of the Rod and is bolted to an Angle Bracket fixed to one of the  $5\frac{1}{2}$ " Angle Girders.

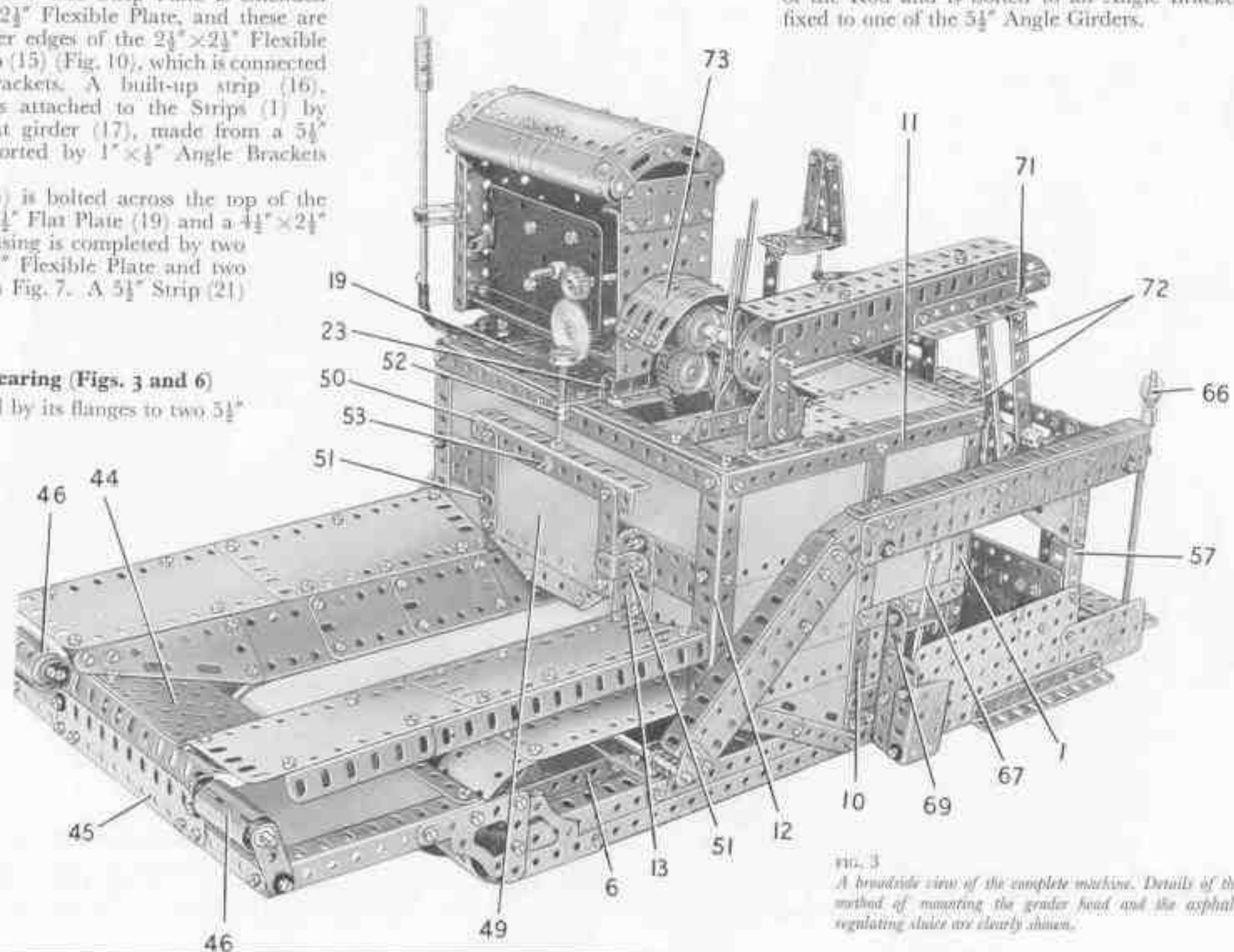

FIG. 3  
A broadside view of the complete machine. Details of the method of mounting the grader head and the asphalt regulating sluice are clearly shown.

A  $\frac{7}{16}$ " diameter Pinion on the Motor armature shaft drives a 60-tooth Gear on a  $2\frac{1}{2}$ " Rod (24) (Fig. 6). A  $\frac{3}{4}$ " Pinion on this Rod engages a 50-tooth Gear on a  $2\frac{1}{2}$ " Rod (25), and this Rod carries a Worm placed between the Motor side-plates. Rod (25) is held in position by a Collar. A  $6\frac{1}{2}$ " Rod supported in the Trunnions bolted to the Girders (22) is fitted with a  $\frac{1}{2}$ " Pinion that is in constant mesh with the Worm. The Pinion is spaced from one of the Trunnions by five Washers, and the  $6\frac{1}{2}$ " Rod carries a  $\frac{3}{4}$ " Sprocket (26) and a 1" Gear (27).

**Details of the Gear-box (Figs. 1, 2, 4, 8 and 9)**

The gear-box provides drives to the travelling wheels, the spreading screws and the conveyor belt. The housing is formed by two  $3\frac{1}{2}$ " x  $2\frac{1}{4}$ " Flanged Plates connected at their lower ends by two  $1\frac{1}{2}$ " Strips. There are three input shafts, each of which is a 2" Rod fitted with a 1" Sprocket (28) and a  $\frac{3}{4}$ " Pinion (29). The Rods are held in place by Collars. The Pinions (29) on the outer Rods are placed against one of the Flanged Plates, but the Pinion on the centre shaft is positioned towards the centre of the Rod.

The output shafts are numbered (30), (31) and (32) in Figs. 8 and 9. Each of these shafts carries a 50-tooth Gear that can be moved into mesh with one of the Pinions (29) by sliding the shaft in its bearings. The levers that control the sliding movements are each fitted with a Rod and Strip Connector that is lock-nutted to an Angle Bracket bolted to the gear-box housing. Two of the levers engage between Collars on the Rods (30) and (31), and the third lever is positioned between a Collar and  $\frac{1}{2}$ " fixed Pulley (33) on Rod (32). Rod (31) carries a  $\frac{3}{4}$ " Sprocket (34), and Rod (30) is fitted with a  $1\frac{1}{2}$ " Pulley (35) (Fig. 9). The Pulley (33) is connected by an endless belt of Spring Cord to one of two 1" loose

Pulleys (36). These Pulleys are placed on a  $\frac{1}{2}$ " Bolt that is screwed tightly into a Threaded Coupling fixed on a  $2\frac{1}{2}$ " Rod. The Rod is held in the gear-box housing by a Collar.

The top flanges of the Flanged Plates are bolted to the Girder (18) and to the Strip (21) (Fig. 1). A  $2\frac{1}{4}$ " Strip fixed to the lower end of the housing carries a  $9\frac{1}{2}$ " Flat Girder (37) (Figs. 8 and 9) and a 1" x 1" Angle Bracket (38) (Fig. 9).

The Flat Girder (37) is connected to the sides of the mechanism housing by 1" x  $\frac{1}{4}$ " Angle Brackets (Fig. 4), and the Angle Bracket (38) is bolted to the Strip (15) (Fig. 10).

A length of Sprocket Chain is passed round the Sprockets (26) and (28) as shown in Fig. 4. The arrangement of the Chain is such that the centre input shaft turns in the opposite direction to the two outer shafts. Thus by sliding shafts (30), (31) and (32) in one direction their 50-tooth Gears can be engaged with the Pinions (29) of the outer pair of input shafts, to engage the drive. When shafts (30), (31) and (32) are moved in the opposite direction their Gears mesh with the Pinion on the centre input shaft, and the direction of the drive is reversed.

The Sprocket (34) (Fig. 8) is connected by Chain to the Sprocket (7) (Fig. 2) to complete the drive to the travelling wheels.

**Drive to the Spreader Screws (Fig. 10)**

In the actual machine the spreader screws used to distribute the surfacing material evenly over the section of the road traversed by the machine are spirals. In the model, however, the spirals are represented by six Bush Wheels and two Wheel Discs on a made-up axle consisting of a  $4\frac{1}{2}$ " Rod and two 2" Rods joined by Couplings (see Fig. 10). The Bush Wheels are fixed on the axle and the Wheel Discs are clamped between the Couplings and Collars. A  $\frac{1}{2}$ " fixed Pulley (39) is fixed at the centre of the axle.

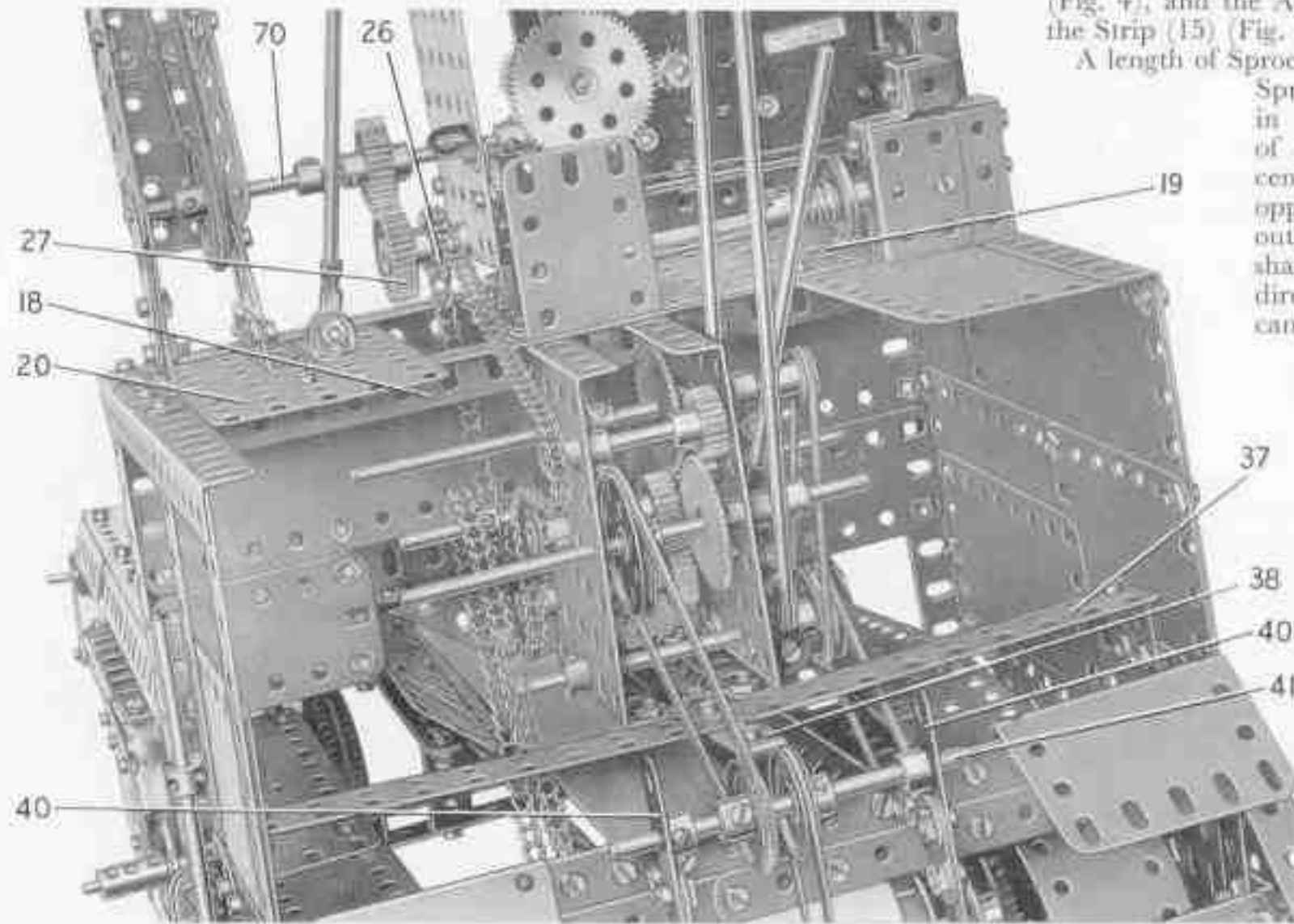

FIG. 4 A close-up, showing driving arrangements from the Electric Motor and gear-box

to distribute the surfacing material evenly over the section of the road traversed by the machine are spirals. In the model, however, the spirals are represented by six Bush Wheels and two Wheel Discs on a made-up axle consisting of a  $4\frac{1}{2}$ " Rod and two 2" Rods joined by Couplings (see Fig. 10). The Bush Wheels are fixed on the axle and the Wheel Discs are clamped between the Couplings and Collars. A  $\frac{1}{2}$ " fixed Pulley (39) is fixed at the centre of the axle.



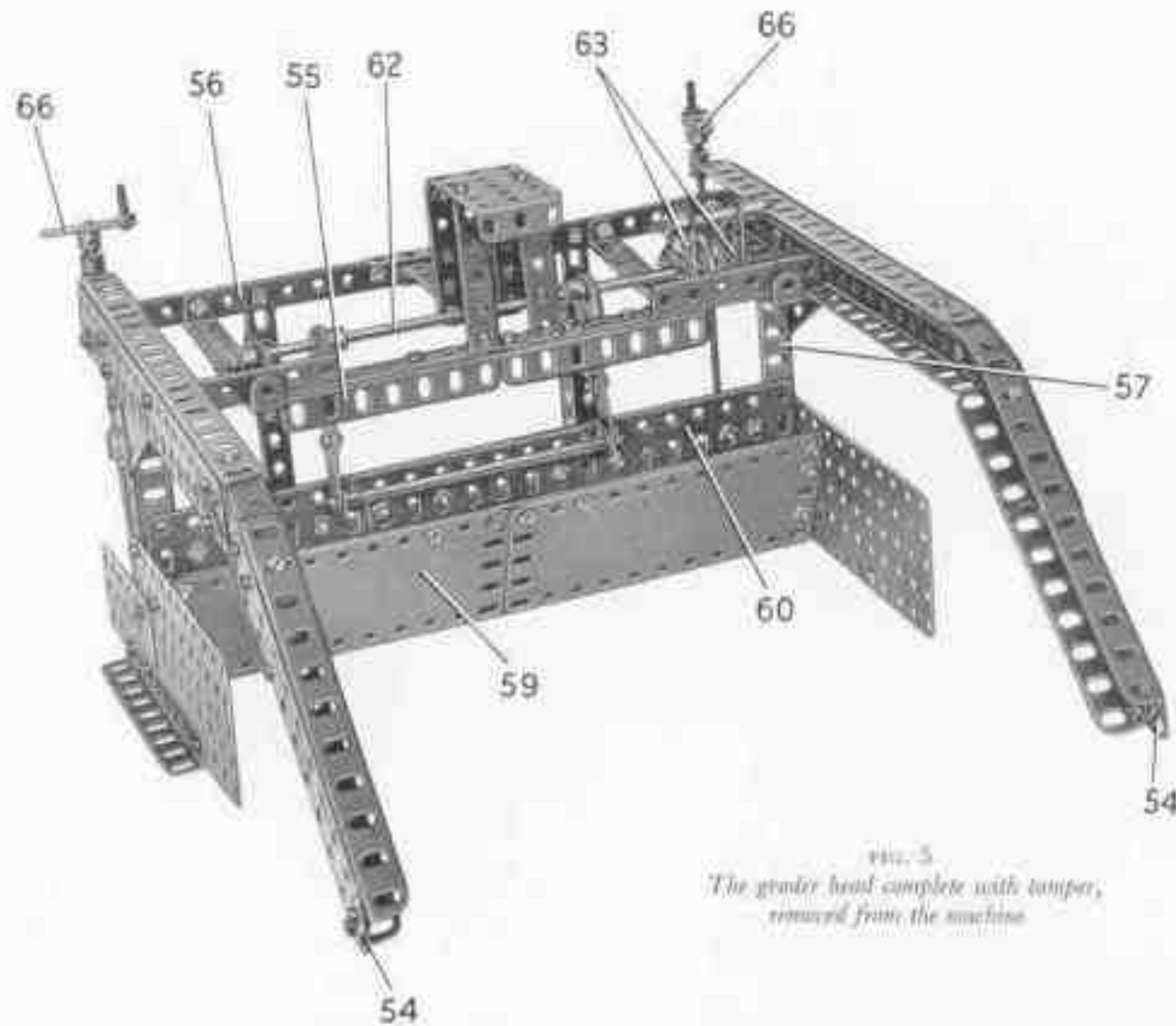

FIG. 5  
The girder head complete with temper,  
removed from the machine

The axle is mounted at each end in three  $2\frac{1}{2}$ " Strips bolted to the main frame, and at the centre it is supported in strips (40), each of which consists of a  $4\frac{1}{2}$ " and a  $3\frac{1}{2}$ " Strip placed face to face. The lower ends of the strips (40) are connected by  $1" \times \frac{1}{2}"$  Angle Brackets to the flat girder (17). Their upper ends are fastened to the lugs of a  $2\frac{1}{2}" \times 1"$  Double Angle Strip, with the joins strengthened by  $1"$  Corner Brackets. The Double Angle Strip is attached to the Strip (15) by  $\frac{3}{4}"$  Bolts, but is spaced from the Strip by four  $2\frac{1}{2}"$  Strips. A  $3\frac{1}{2}"$  Rod (41) mounted in the strips (40) is fitted with two  $1"$  Pulleys. One of these Pulleys is connected by a Driving Band to the  $\frac{1}{2}"$  Pulley (39), and the other is driven by an endless belt of Spring Cord passed round the Pulley (35) of the gear-box (Fig. 9).

**Arrangement of the Hopper and Conveyor (Figs. 2, 3, 9 and 10)**

The sloping sides of the hopper (Fig. 3) are each formed by four  $2\frac{1}{2}" \times 1\frac{1}{2}"$  Flexible Plates and a  $3\frac{1}{2}" \times 1\frac{1}{2}"$  Triangular Flexible Plate bolted to a built-up strip (42) (Fig. 2) on each side. These strips are made

from  $12\frac{1}{2}"$  and  $5\frac{1}{2}"$  Strips overlapped seven holes, and at their rear ends they are supported by Corner Angle Brackets fixed to the Strip (15) (Fig. 10) by bolts (43). The top edges of the sloping Plates on each side are connected by five Obtuse Angle Brackets to two  $5\frac{1}{2}" \times 2\frac{1}{2}"$  Flexible Plates, strengthened along their inner edges by two  $5\frac{1}{2}"$  Strips. The outer edges of the  $5\frac{1}{2}" \times 2\frac{1}{2}"$  Flexible Plates are braced by a  $7\frac{1}{2}"$  and a  $3"$  Angle Girder, as shown in Fig. 3. The  $7\frac{1}{2}"$  Angle Girders are connected by Angle Brackets to the Girders (12).

The front corners of the Triangular Flexible Plates are connected by Obtuse Angle Brackets to a  $5\frac{1}{2}" \times 2\frac{1}{2}"$  Flat Plate (44), which is edged by a  $5\frac{1}{2}"$  Angle Girder. This Girder is joined by Fishplates to a  $5\frac{1}{2}"$  Flat Girder (45), and the latter is extended at each side by a  $3"$  Strip. The  $3"$  Strips are connected by Angle Brackets to the front end of the main frame. Two rollers are seen at (46). These are Sleeve Pieces fitted over Chimney Adaptors, which are freely mounted on Rods fixed in Cranks bolted to the main frame. The inner ends of the Rods are supported in Angle Brackets attached to the  $5\frac{1}{2}"$  Angle Girder.

A supporting plate for the conveyor belt is provided by a  $5\frac{1}{2}" \times 3\frac{1}{2}"$  Flat Plate (47) (Fig. 2). This is attached to the strip (4) by two  $\frac{3}{4}"$  Bolts, but is spaced from the strip by nuts, and is supported also by two  $1"$  Reversed Angle Brackets bolted to the strip (3) also seen in this view.

The driving roller for the conveyor belt is formed by two  $1\frac{1}{2}"$  Flanged Wheels pressed into the ends of a Cylinder, around which two  $2\frac{1}{2}"$  Driving Bands are

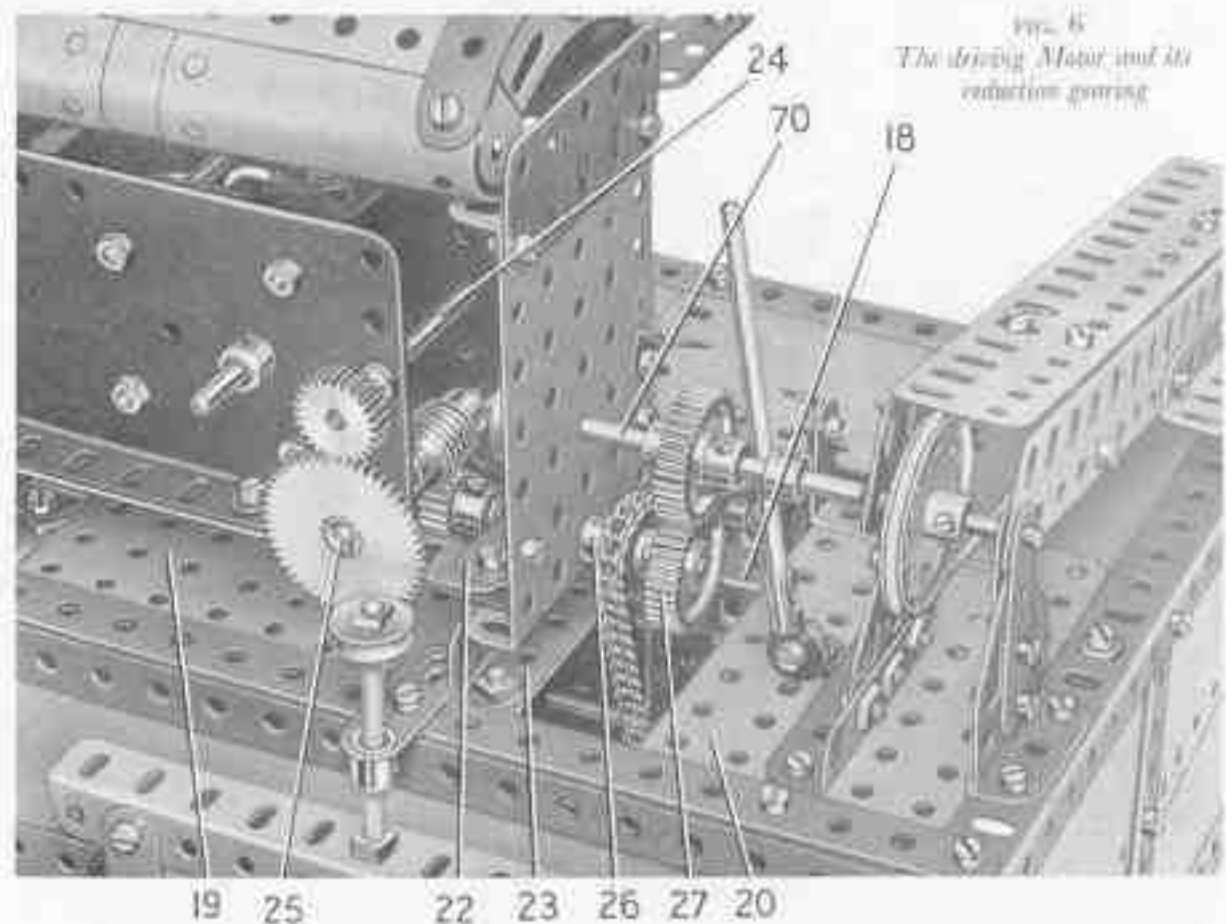

FIG. 6  
The driving Motor and its  
reduction gearing

then placed. The roller is fixed on a 4" Rod supported in two 2" Strips (48) (Fig. 10), which are attached by Angle Brackets to the Strip (15) and the built-up strip (16). A 1" Pulley on the Rod is connected to the outer one of the two Pulleys (36) (Fig. 9) by an endless belt of Spring Cord. The idling roller is also made from a Cylinder and two 1½" Flanged Wheels, and it is fixed on a 4" Rod supported in the Girders (5) (Fig. 2). The conveyor belt can be made from an endless length of cloth or strong paper passed round the rollers.

### The Feed Regulating Sluice (Fig. 3)

The flow of road surfacing material along the conveyor can be controlled by means of an adjustable sluice gate (49) (Fig. 3). This consists of a 4½" × 2½" Flexible Plate edged by a 5½" Angle Girder (50) and two 2½" Strips. The Flexible Plate is extended downward by two 2½" × 2" Triangular Flexible Plates, which are connected at their lower corners by a 2" Flat Girder. The gate slides between the Girders (13) and ½" Reversed Angle Brackets (51) bolted to the Girders but spaced from them by a Washer on each bolt.

A ½" loose Pulley is fixed between two nuts on a 3½" Screwed Rod, which is then screwed through a Threaded Crank (52) fixed as shown in Fig. 3. The Screwed Rod passes through the Girder (50) and through the long bore of a Coupling attached inside the gate by a nut and bolt (53). Lock-nuts are placed on the Screwed Rod above the Girder (50) and below the Coupling.

### Building the Grader Head (Figs. 1, 2, 3, 5 and 7)

The grader head (Fig. 5) is supported in the machine by a pivoted arm on each side. These arms are each made from a 9½" Flat Girder fitted with two 9½" Angle Girders, and a 3½" Flat

FIG. 7  
A semi-plan view from the rear, showing the general layout of the Road Surfacing Machine

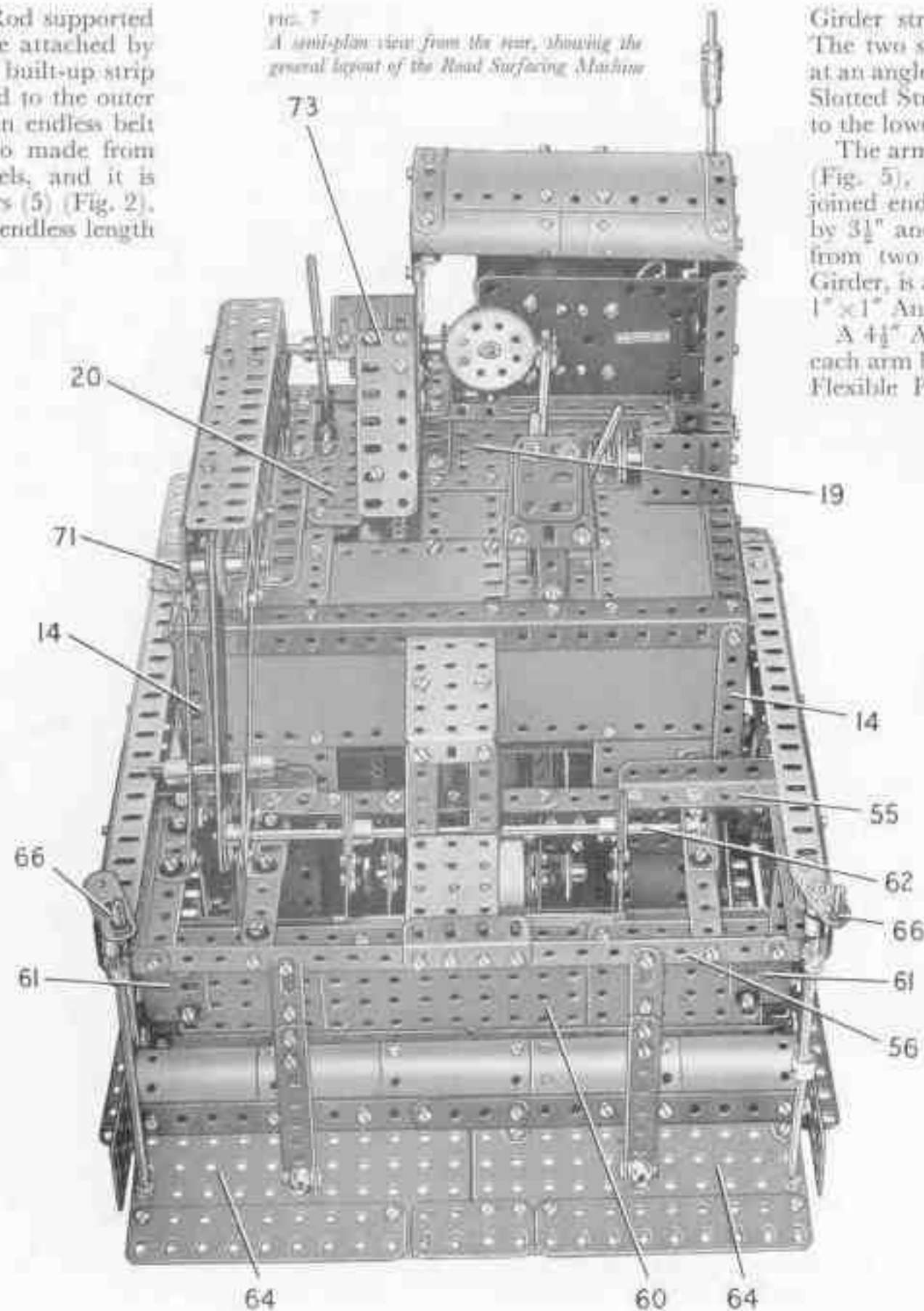

Girder strengthened by two 5½" Angle Girders. The two sections of each arm are joined together at an angle by two 2½" Curved Strips and a Formed Slotted Strip. A 1" Triangular Plate (54) is bolted to the lower end of each arm.

The arms are connected by a bridging piece (55) (Fig. 5), made as shown from two 5½" Strips joined end-to-end by a 3" Strip and strengthened by 3½" and 3" Angle Girders. A strip (56), made from two 5½" Strips connected by a 2" Angle Girder, is attached to the front ends of the arms by 1" × 1" Angle Brackets.

A 4½" Angle Girder (57) (Fig. 5) is attached to each arm by a 2½" Strip and a 3½" × 2½" Triangular Flexible Plate. The lower ends of these Girders are connected by a built-up girder (58) (Fig. 2) made from two 5½" Angle Girders joined at the centre by a 2" Strip. A 5½" × 2½" Flat Plate and a 3" × 1½" Flat Plate are bolted to each of the Girders (57) and are connected on the outside by a 4½" Angle Girder. A plate (59) (Fig. 5) is attached at an angle to the 5½" × 2½" Flat Plates by 1½" Angle Girders. This plate consists of two 5½" × 2½" Flexible Plates bolted to two 5½" Strips, which are connected end-to-end by a 3" Strip.

A tamping device (60) (Figs. 1 and 5) consists of two 4½" × 2½" Flat Plates that overlap a central 4½" × 2½" Flat Plate, one by four holes and the other by three holes. A 7½" Flat Girder extended by a 3½" Flat Girder fixed to the Plates, is arranged so that the ends of the Flat Girders are located behind the flanges of the Girders (57).

A 1½" Flat Girder (61) (Fig. 7) at each end of the tamping plate in front of Girder (57), is spaced from the plate by a Washer on each bolt, and the complete plate slides freely over the flanges of the Girders (57). The tamping plate is given an up and down movement by two Single Throw Eccentrics on an 8" Rod (62). The Eccentrics are extended by 2" Strips



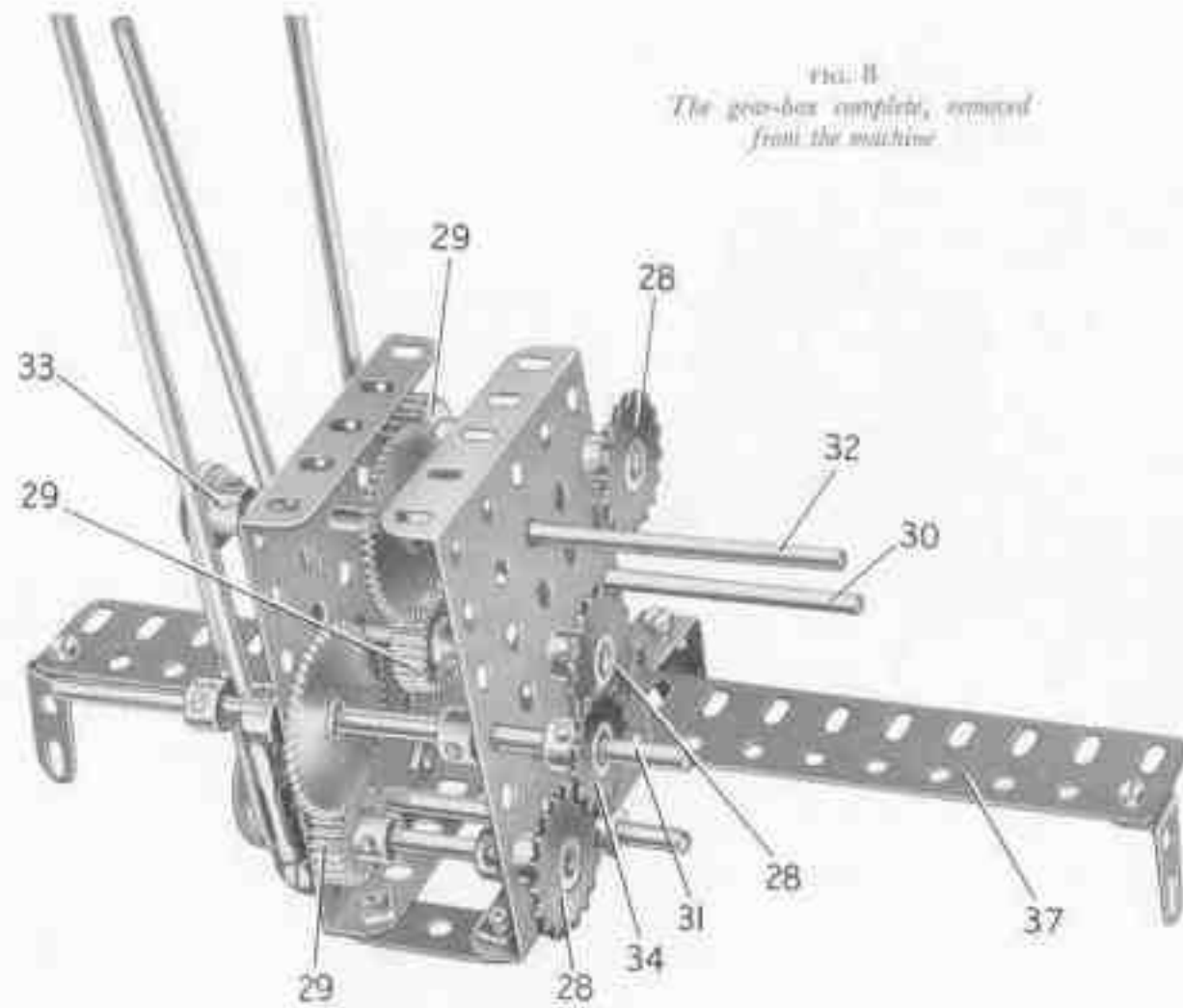

FIG. 8  
The gear-box complete, removed  
from the machine

that pivot freely on a 5" Rod, which is held by Spring Clips in a 4½" x ½" Double Angle Strip bolted behind the tamping plate. At one end the Rod (62) is supported in a 1½" Angle Girder bolted to a 4½" x ½" Double Angle Strip fixed to the strip (56) (Fig. 5) and the bridging piece (55). The other end of the Rod is mounted in a 1½" Angle Girder fixed to a 3½" Strip bolted to the bridging piece and connected to strip (56) by a 1" x ½" Angle Bracket. The last-mentioned 1½" Angle Girder supports one of two 1½" Corner Brackets (63). The other Corner Bracket is fixed to another 1½" Angle Girder bolted to a 4½" x ½" Double Angle Strip.

Two 5½" x 3½" Flat Plates (64) (Fig. 2) are pivotally connected to the girder (58) by Hinges held by bolts (65). The inner edges of the Flat Plates are loosely connected by a lock-nutted ½" Bolt passed through an Angle Bracket bolted to each Flat Plate at its rear inner corner. The front edges of the Flat Plates (64) carry Flat Girders, as shown in Fig. 7.

Each Flat Plate can be adjusted vertically by turning a handle (66) on the shank of an Adaptor for Screwed Rod fixed by a nut at the top end of a Screwed Rod. The two Screwed Rods are passed through the threaded holes of Handrail Supports fixed at the ends of the strip (56). The lower ends of the Screwed Rods turn freely in the Flat Plates (64) and each is held in place by two sets of lock-nuts, one set above and one below the Plate. On one side a 6"

Screwed Rod is used, but on the other side two 3" Screwed Rods are connected by a Threaded Boss and are fixed tightly in it by nuts. A 3½" Angle Girder is fixed by two nuts on a ½" Bolt that is mounted freely in a Handrail Support bolted to each of the Flat Plates (64). The Angle Girder is extended upward by a 2" Slotted Strip, the slotted hole of which is passed over a bolt held by two nuts in the strip (56). The join between the Slotted Strip and the Angle Girder is strengthened by a 1½" Strip.

Five U-section Curved Plates seen in Figs. 1 and 7 represent the cover of the heaters of the actual machine. The assembly is connected to one of the Flat Plates (64) by Angle Brackets.

The Triangular Plates (54) of the grader head (Fig. 5) are passed over the ends of an 11½" Rod that is held by Couplings in 2½" x ½" Double Angle Strips bolted to the strip (3) (Fig. 2). A 4½" Rod (67) (Figs. 1 and 3) on each side is fitted in a Coupling held on a Threaded Pin fixed in a 3" Angle Girder (68) (Fig. 10). The Rod is supported by a 1" Reversed Angle Bracket attached to a vertical 2½" Angle Girder (69). A Girder Bracket is attached to this Angle Girder by means of a 2½" Flat Girder. The Rods (67) pass through the arms of the grader head, and the arms are supported on the Rods by 'spiders' obtained from Swivel Bearings (see Figs. 1 and 3).

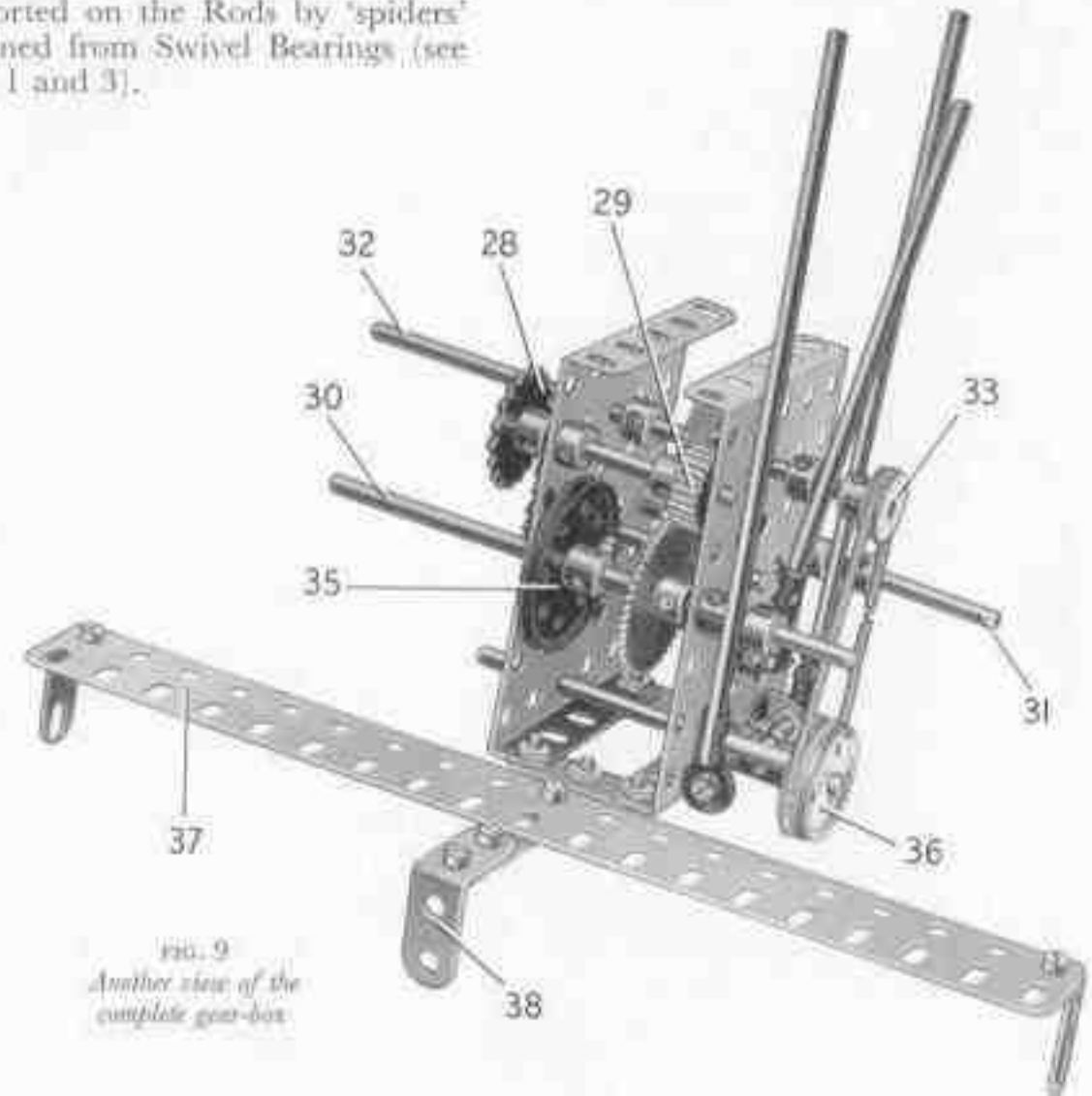

FIG. 9  
Another view of the  
complete gear-box

### The Tamper Drive

(Figs. 3, 4, 6 and 7)

A  $4\frac{1}{2}$ " Rod (70) (Figs. 4 and 6) is mounted in one end of the engine housing and in two 2" Strips, each of which is fixed to a Flat Trunnion. One of the Flat Trunnions is supported by a  $1\frac{1}{2}$ " Angle Girder and the other is attached to a 2" Angle Girder. Rod (70) carries a 1" Gear, and by sliding the Rod this Gear can be meshed with the Gear (27). Movement of the Rod is controlled by a  $3\frac{1}{2}$ " Rod that engages between Collars on Rod (70). The  $3\frac{1}{2}$ " Rod is fitted at its lower end with a Rod and Strip Connector, which is lock-mitted to an Angle Bracket bolted to the Flat Plate (20).

A  $1\frac{1}{2}$ " Pulley on Rod (70) is connected by an endless belt of Spring Cord to a 1" Pulley on a  $1\frac{1}{2}$ " Rod (71) (Fig. 7). Rod (71) carries a second 1" Pulley and is mounted at the end of an arm that pivots on Rod (70). This arm consists of three  $7\frac{1}{2}$ "

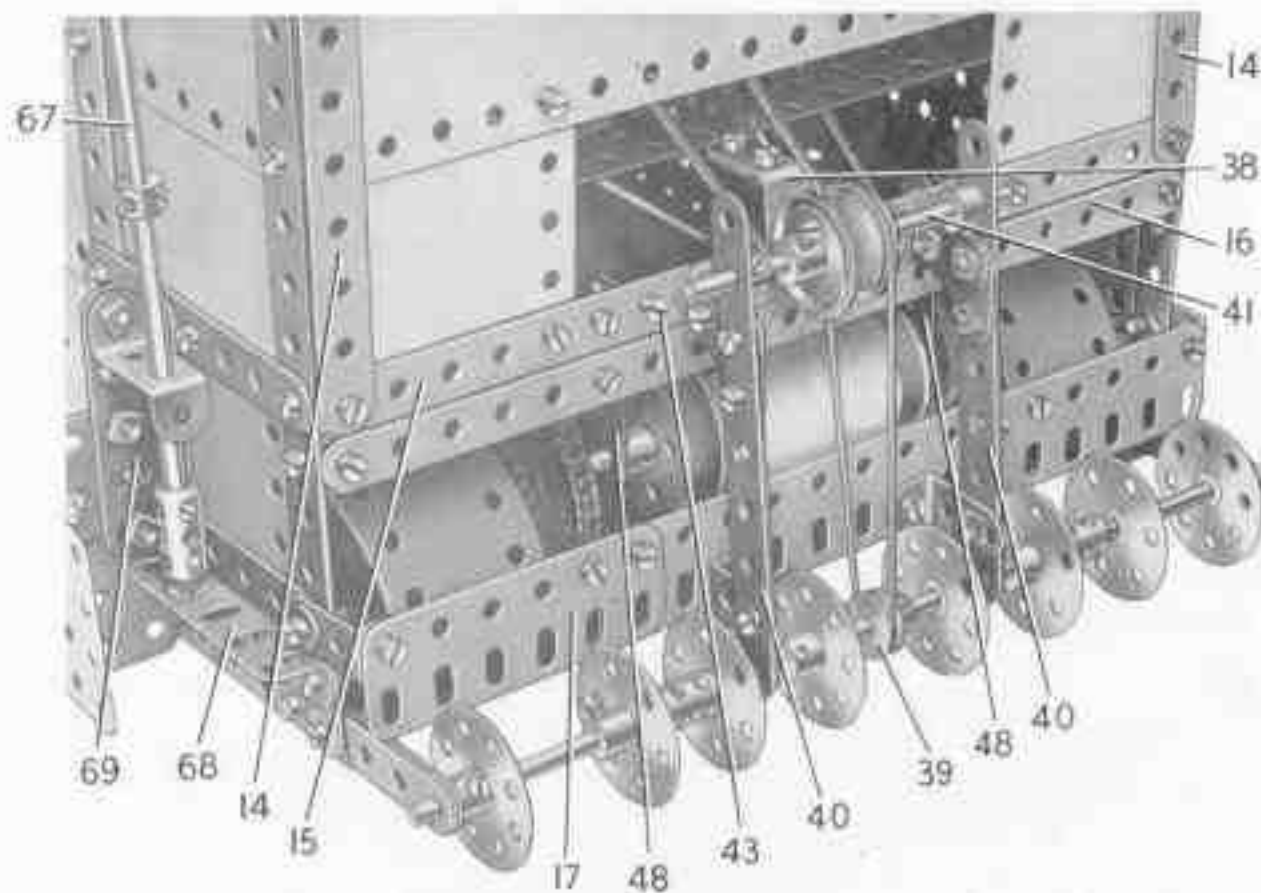

FIG. 10. The road surfacing material is distributed evenly over the highway as the machine travels along by means of a distribution spiral, represented in the model by a row of revolving Bush Wheels.

Flat Girders connected by  $1" \times 1"$  and  $1" \times \frac{1}{2}"$  Angle Brackets to form a deep section channel girder. It is extended at one end by two 3" Strips and two  $2\frac{1}{2}"$  Stepped Curved Strips (see Fig. 1). A  $3\frac{1}{2}"$  Angle Girder is bolted to each side of the arm, and two  $3\frac{1}{2}"$  Strips (72) are lock-mitted to Angle Brackets fixed to these Girders. The lower ends of the Strips (72) pivot on a  $1\frac{1}{2}"$  Rod that is held by Rod Sockets in the Corner Brackets (63). The second 1" Pulley on Rod (71) is connected by a Driving Band to a 1" Pulley on the end of Rod (62) (Fig. 7).

A cover plate (73) (Fig. 7) is made from three Formed Slotted Strips joined by  $1\frac{1}{2}"$  Strips and extended by a  $3\frac{1}{2}"$  Flat Girder. It is attached to one end of the engine housing by an Angle Bracket, and is supported by a  $\frac{1}{2}" \times \frac{1}{2}"$  Angle Bracket and a  $1" \times 1"$  Angle Bracket bolted as shown in Fig. 7 to the Flat Plate (20).

### Parts Required to Build the Meccano Road Surfacing Machine

4 of No. 1	8 of No. 9d	2 of No. 16b	4 of No. 27	2 of No. 35a	4 of No. 50	4 of No. 109	1 of No. 154b	2 of No. 196
4 - - 1a	4 - - 9e	3 - - 17	1 - - 27d	1 - - 38	2 - - 90a	4 - - 111a	2 - - 160	12 - - 199
6 - - 11b	8 - - 9f	2 - - 18a	2 - - 31	24 - - 39	1 - - 94	17 - - 111c	2 - - 161	4 - - 212
20 - - 2	7 - - 10	4 - - 20	2 - - 32	2 - - 62	1 - - 95	2 - - 114	2 - - 163	5 - - 215
4 - - 2a	2 - - 11	4 - - 20a	3 - - 35	1 - - 62a	3 - - 96	4 - - 115	4 - - 164	2 - - 216
12 - - 3	47 - - 12	1 - - 20b	599 - - 37a	2 - - 62b	2 - - 96a	4 - - 124	2 - - 165	2 - - 221
8 - - 4	7 - - 12a	2 - - 31	569 - - 37b	8 - - 63	1 - - 102	5 - - 125	2 - - 173a	2 - - 224
20 - - 5	8 - - 12b	7 - - 22	70 - - 38	1 - - 63c	4 - - 103	2 - - 126	2 - - 179	2 - - 225
12 - - 6	12 - - 12c	2 - - 22a	1 - - 43	1 - - 64	4 - - 103a	2 - - 126a	2 - - 186	2 - - 226
7 - - 6a	1 - - 13	1 - - 23	1 - - 46	3 - - 70	2 - - 103c	2 - - 130a	1 - - 186a	
4 - - 8	2 - - 13a	2 - - 23a	4 - - 48	1 - - 72	2 - - 103d	4 - - 133	1 - - 186c	
6 - - 8a	4 - - 14	4 - - 24	4 - - 48a	2 - - 73	2 - - 103e	2 - - 133a	12 - - 188	
4 - - 8b	6 - - 15	2 - - 24b	3 - - 48c	2 - - 77	4 - - 103f	4 - - 136	12 - - 189	
12 - - 9	5 - - 15a	2 - - 24c	2 - - 51	1 - - 79a	2 - - 103g	1 - - 140	4 - - 190	
8 - - 9a	2 - - 15b	4 - - 25	4 - - 52a	1 - - 80a	3 - - 103h	4 - - 142a	4 - - 190a	
8 - - 9b	2 - - 16	1 - - 26	3 - - 53	2 - - 80c	4 - - 103k	1 - - 144	10 - - 191	
4 - - 9c	6 - - 16a	1 - - 26c	4 - - 53a	2 - - 80a	4 - - 100	1 - - 154a	9 - - 192	

1 E15R  
Electric Motor  
(not included  
in Outfit)