

# MECCANO

## Bottom Dump Truck

MODEL No. 10.18

### SPECIAL FEATURES

A two-speed and reverse gear-box in the motor power unit, and special mechanism for controlling the opening and closing of the dumping doors, are attractive features of the Bottom Dump Truck described in this Leaflet. The model is an interesting one to build and operate and it is powered by an E15R type 15-20-volt Electric Motor.

FIG. 1  
The Bottom Dump Truck in its completed state. An E15R 15-20-volt Electric Motor is concealed under the bonnet of the power unit.

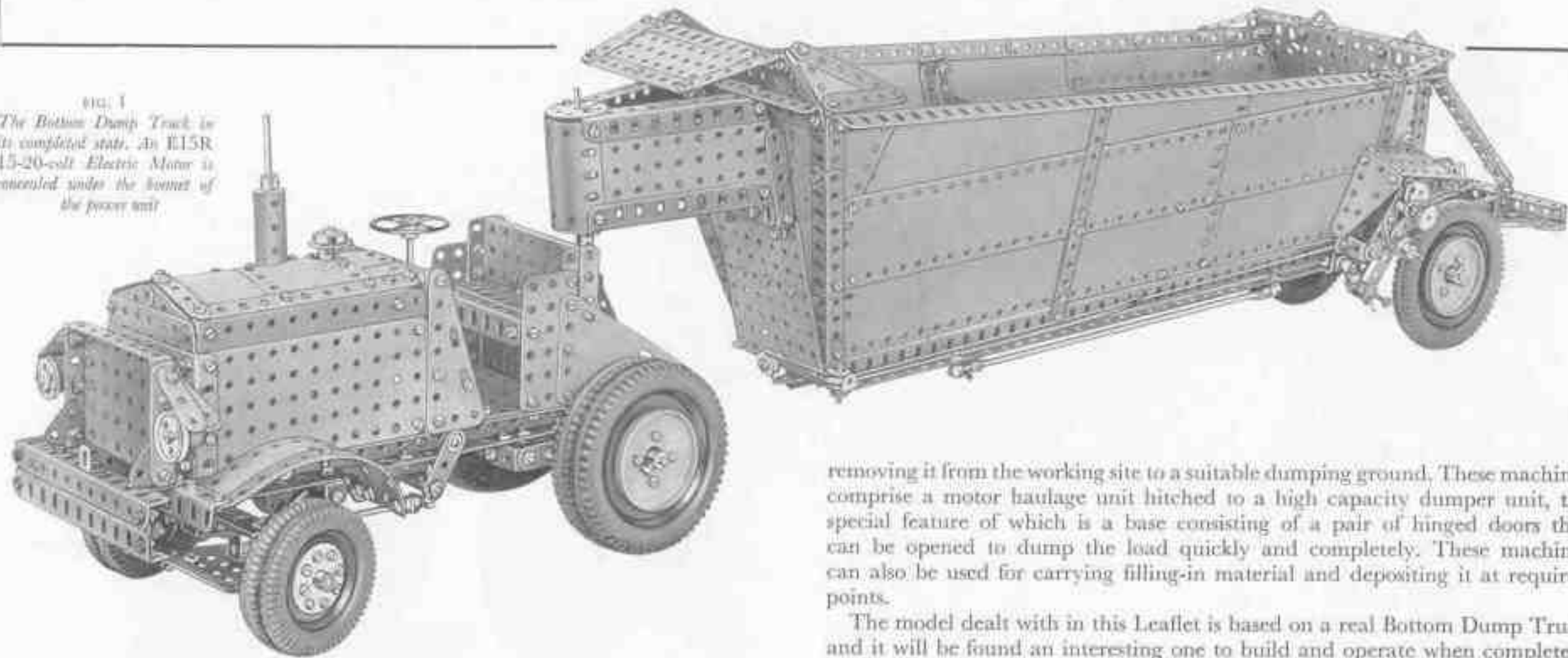

removing it from the working site to a suitable dumping ground. These machines comprise a motor haulage unit hitched to a high capacity dumper unit, the special feature of which is a base consisting of a pair of hinged doors that can be opened to dump the load quickly and completely. These machines can also be used for carrying filling-in material and depositing it at required points.

The model dealt with in this Leaflet is based on a real Bottom Dump Truck and it will be found an interesting one to build and operate when completed. It is best to commence construction with the motor power unit.

### Construction of the Power Unit Chassis (Figs. 2 and 7)

Each side-member of the power unit chassis consists of two 12½" Angle Girders bolted together to form a channel section girder. At the rear the

Machines used in the preparation of large building sites and in the work on modern civil engineering projects such as dams, road and drainage schemes, bridges, etc., take many forms, and most of them provide splendid subjects for the Meccano model-builder. One fine example is the Bottom Dump Truck used for conveying spoil excavated by mechanical shovels, grab cranes, etc., and

FIG. 2  
This illustration shows details of  
the power unit chassis, motor  
mounting and steering gear

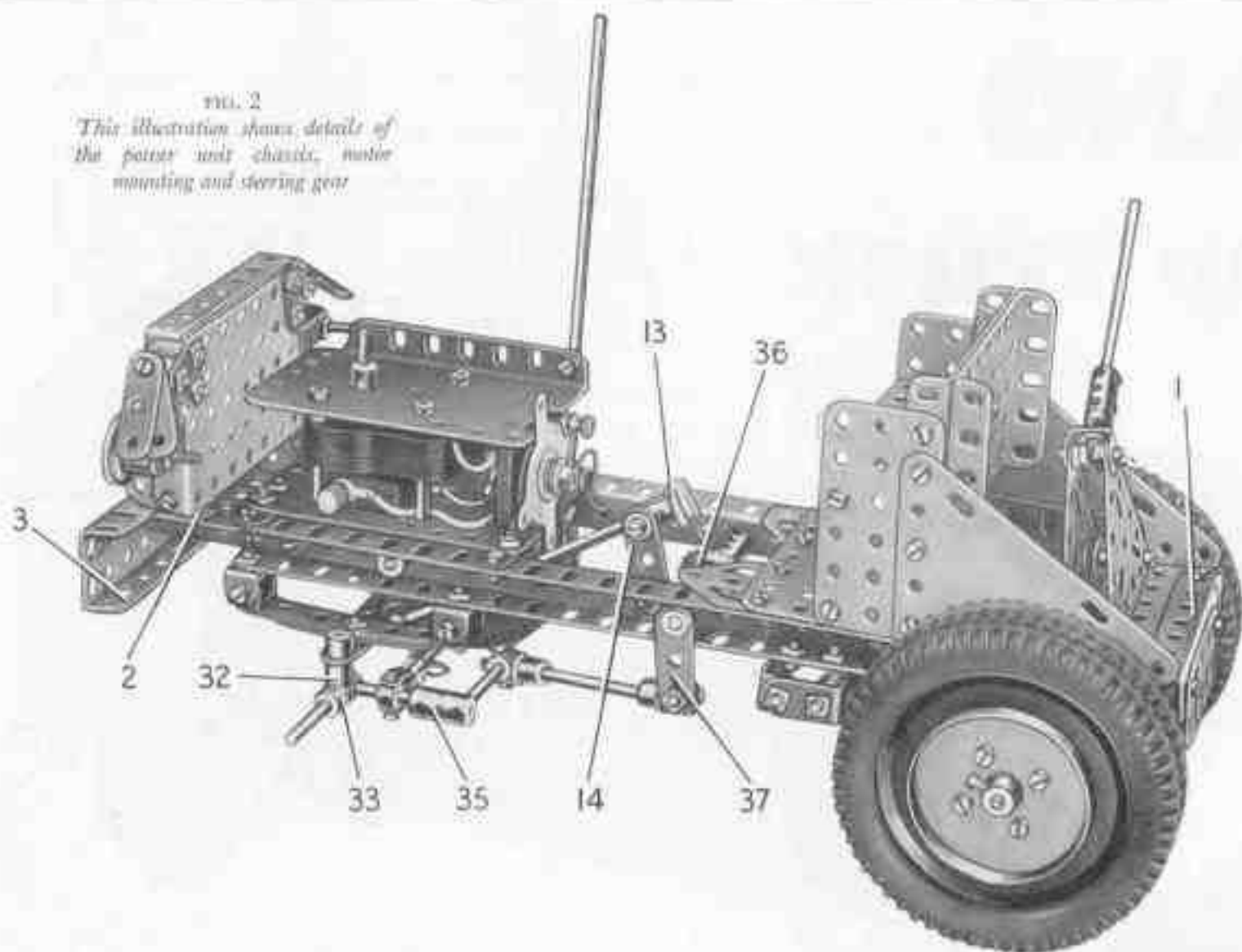

side-members are connected by a  $5\frac{1}{2}'' \times 3\frac{1}{2}''$  Flat Plate and a  $3\frac{1}{2}''$  Angle Girder (1), to which a  $2\frac{1}{2}''$  Flat Girder is bolted. Each side-member is extended forward three clear holes by a  $2\frac{1}{2}''$  Angle Girder (2) (Fig. 7), and to these is bolted a  $5\frac{1}{2}''$  Angle Girder. A  $5\frac{1}{2}''$  Flat Girder is fixed to the  $5\frac{1}{2}''$  Angle Girder to support a further  $5\frac{1}{2}''$  Angle Girder (3). Two Flat Trunnions are bolted to the front edge of the  $5\frac{1}{2}'' \times 3\frac{1}{2}''$  Flat Plate as shown in Fig. 2.

#### The Power Unit, Clutch and Gear-Box (Figs. 2, 4, 6 and 7)

An E15R Electric Motor is bolted by one of its flanges to one side-member of the chassis, and is connected to the other side-member by two Fishplates (see Fig. 2). The frame of the gear-box consists of two  $3'' \times 1\frac{1}{2}''$  Double Angle Strips bolted together by their lugs, with a  $1\frac{1}{2}''$  Flat Girder attached at each end by bolts passed through its slotted holes. To one of the Flat Girders is fixed a Double Bent Strip (4) (Fig. 4), and to each Double Angle Strip is bolted a  $1''$  Corner Bracket (5) (Fig. 6). A  $1'' \times 1''$  Angle Bracket (6) is attached

to one side of the frame but is spaced from it by a  $1\frac{1}{2}''$  Strip. At one end of the frame a  $2''$  Strip (7) is attached.

Two Angle Brackets also are bolted to one side of the frame, and these are fixed direct to the chassis side-member. Two further Angle Brackets are spaced from the other side of the frame by a Washer on each bolt, and a  $1\frac{1}{2}''$  Flat Girder bolted to these Angle Brackets (see Fig. 6) is attached to the chassis.

A Worm is fixed on the Motor shaft and is arranged to drive a  $\frac{1}{2}''$  diameter,  $\frac{1}{2}''$  face Pinion (8) (Fig. 7) fixed on a  $3\frac{1}{2}''$  Rod. This Rod is mounted in the Strip (7) and in a  $1\frac{1}{2}''$  Flat Girder (9) that is supported by a  $1\frac{1}{2}''$  Angle Girder bolted to the Motor. The Pinion (8) is spaced from the Flat Girder by four Washers and the Rod is held in position by a Collar. The  $3\frac{1}{2}''$  Rod also carries a  $\frac{1}{2}'' \times 1''$  Pinion that drives a 57-tooth Gear (10) on a  $5''$  Rod (11). This Rod is supported in the Flat Girder (9) and in one end of the gear-box frame, and it forms the gear-box main shaft. The Gear (10) is gripped in a Socket Coupling (12) that is free to turn on Rod (11). The Gear is pressed by a Compression Spring against a Motor Tyre on a  $1''$  Pulley fixed on Rod (11). The Compression Spring is placed between the Socket Coupling (12) and a Collar, and this assembly forms the clutch mechanism.

The clutch is disengaged by pressing a pedal (13) (Fig. 5), formed by a Slide Piece on a  $4''$  Rod. A Collar is fixed on this Rod immediately below the Slide Piece, and a  $1\frac{1}{2}''$  Strip (14)

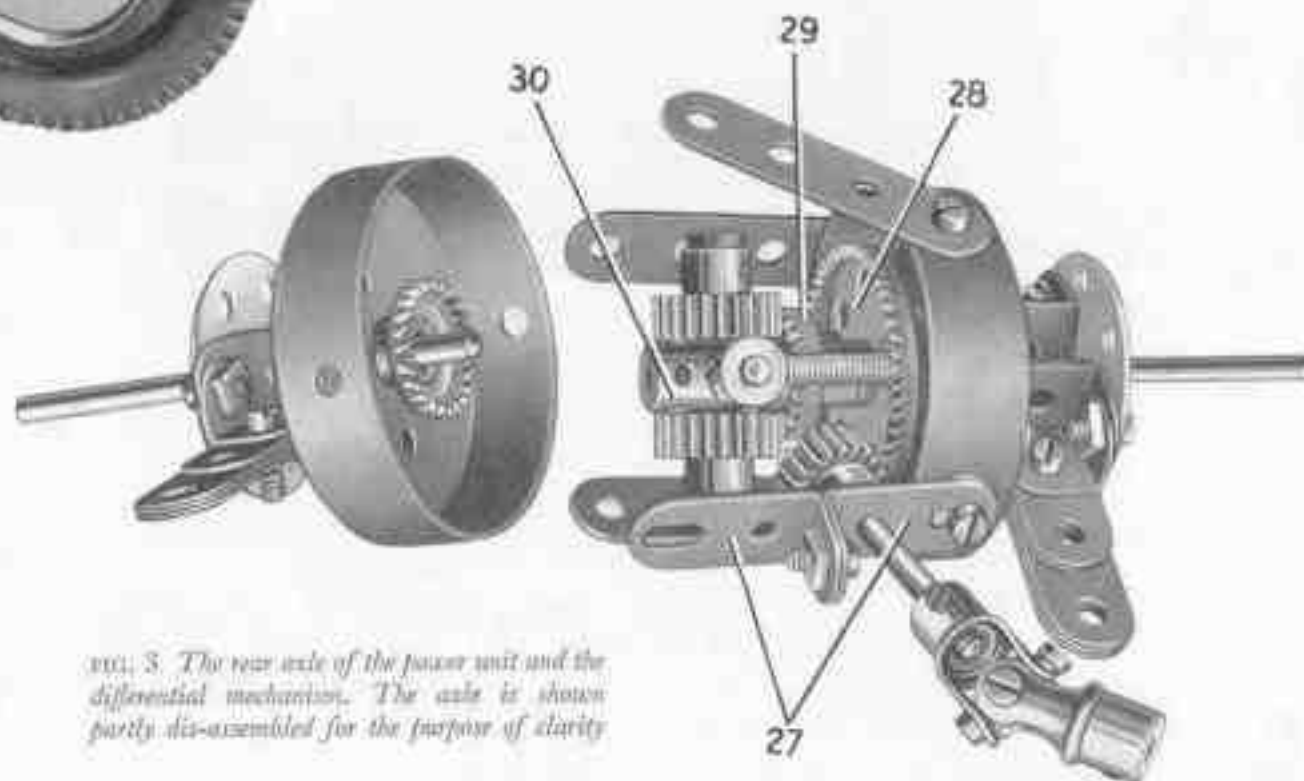

FIG. 3 The rear axle of the power unit and the differential mechanism. The axle is shown partly dis-assembled for the purpose of clarity



(Fig. 2) is pivoted on a bolt screwed into the Collar. The lower end of Strip (14) is lock-nutted to the chassis. A Rod and Strip Connector fitted to the lower end of the 4" Rod is lock-nutted to one arm of a Bell Crank on a 3" Rod, which is mounted in the chassis girders and is held in place by a Collar. A second Bell Crank (15) is fixed on the 3" Rod, and a Threaded Pin held in one of its arms engages the groove in the Socket Coupling (12).

The Rod (11) (Figs. 6 and 7) carries, inside the gear-box frame, a Collar, a 3/4" Pinion (16) and a 1/2" Pinion (17). The Rod projects about 1/4" beyond Pinion (17) into a 1/2" Pinion (18) on the output shaft. This shaft is a 2 1/2" Rod mounted in one end of the frame and in the 1" x 1" Angle Bracket (6), and it carries also a 7/8" diameter, 1/2" face Pinion (19) (Fig. 6).

The layshaft is a 3 1/4" Rod fitted with a 1/2" Pinion (20) (Fig. 7), a Collar and a 3/4" Pinion (21). The layshaft is mounted as shown (in Fig. 7) and is free to slide in its bearings, but the sliding movement is limited by one half of a Dog Clutch, which serves as a Collar. A 1/2" reverse Pinion (22) (see Fig. 4) is retained on a 1 1/2" Rod by a Spring Clip but is free to turn on the Rod. The Rod is fixed in the centre cross hole of a Coupling (23), which is screwed as shown on to a bolt at one end of the frame. It should be noted that one of the bolts supporting the Double Bent Strip (4) (Figs. 4 and 7) is fitted with a nut before it is passed through the frame, so that the shank of the bolt is clear of the Coupling (23).

The sliding movement of the layshaft is controlled by a lever (24) (Fig. 6) which is formed by a 3" Strip lock-nutted at its lower end to the chassis. A Collar is screwed on to a bolt fixed in the lever by a nut, and a 1 1/2" Bolt fixed in the Collar is fixed also in a Swivel Bearing (25) (Fig. 6). A 3/4" Bolt passed through the boss of the Swivel Bearing is screwed into a Collar fixed on a 2" Rod mounted in the Corner Brackets (5). A Crank (26) is fixed on the Rod, with a Compression Spring between it and one of the Corner Brackets (5), and a 1/2" Bolt held in the Crank by two nuts engages between the Pinion (21) and the Collar on the layshaft (Fig. 7).

Top gear is obtained by sliding the layshaft so that Pinion (21) (Fig. 7) engages both Pinions (17) and (18) (Fig. 6). Second gear is provided by meshing Pinion (19) (Fig. 6) with Pinion (20) (Fig. 7) and Pinion (21) (Fig. 7) with Pinion (17) (Fig. 6). Reverse is obtained when Pinion (19) (Fig. 6) is in mesh with Pinion (20) and Pinion (21) engages the reverse Pinion (22) (Fig. 7), which is in constant mesh with Pinion (16) (Fig. 6).

**Rear Axle and Differential (Figs. 3 and 7)**

Each half of the rear axle casing (Fig. 3) consists of a Boiler

End and a Wheel Disc (six holes) connected to each other by two Double Brackets. When the differential mechanism is assembled the halves of the casing are joined together by bolting three 2" Strips and two 1" x 1/2" Angle Brackets (27) between the Boiler Ends.

A 3 1/4" Rod is passed through one half of the casing and on it a 1 1/2" Contrate (28) is mounted freely. A 3/4" Contrate (29) is fixed on the Rod, which extends into a Coupling (30). Two 1" Screwed Rods are fixed by nuts in the Contrate (28) and on each of them a Collar is screwed as shown. A 1 1/2" Rod passed through the Coupling (30) is fixed in the Collars. Two 3/4" Pinions are mounted freely on Pivot Bolts, which are screwed into the Coupling (30) opposite to each other. These Pinions engage the Contrate (29), and mesh also with a similar Contrate on a 3" Rod passed through the other half of the axle casing. Washers are placed on the 3" and 3 1/4" Rods so that the Pinions and Contrates mesh accurately, and so that the Contrate (28) engages a 1/2" Pinion on a 1 1/2" Rod supported in one of the Angle Brackets (27). This Rod is connected by a Universal Coupling to the gear-box output shaft (see Fig. 7).

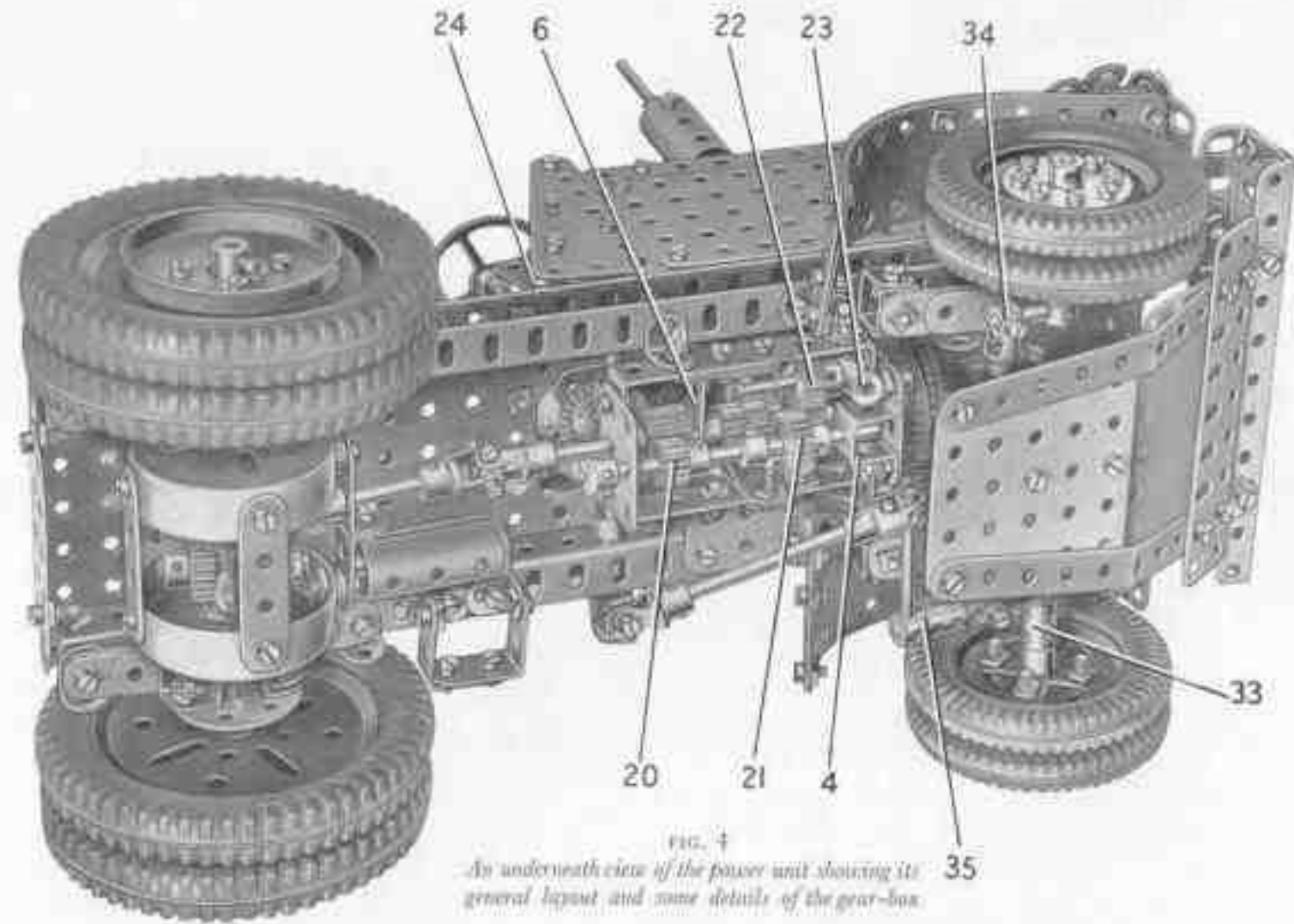

FIG. 4  
An underneath view of the power unit showing its general layout and some details of the gear-box.

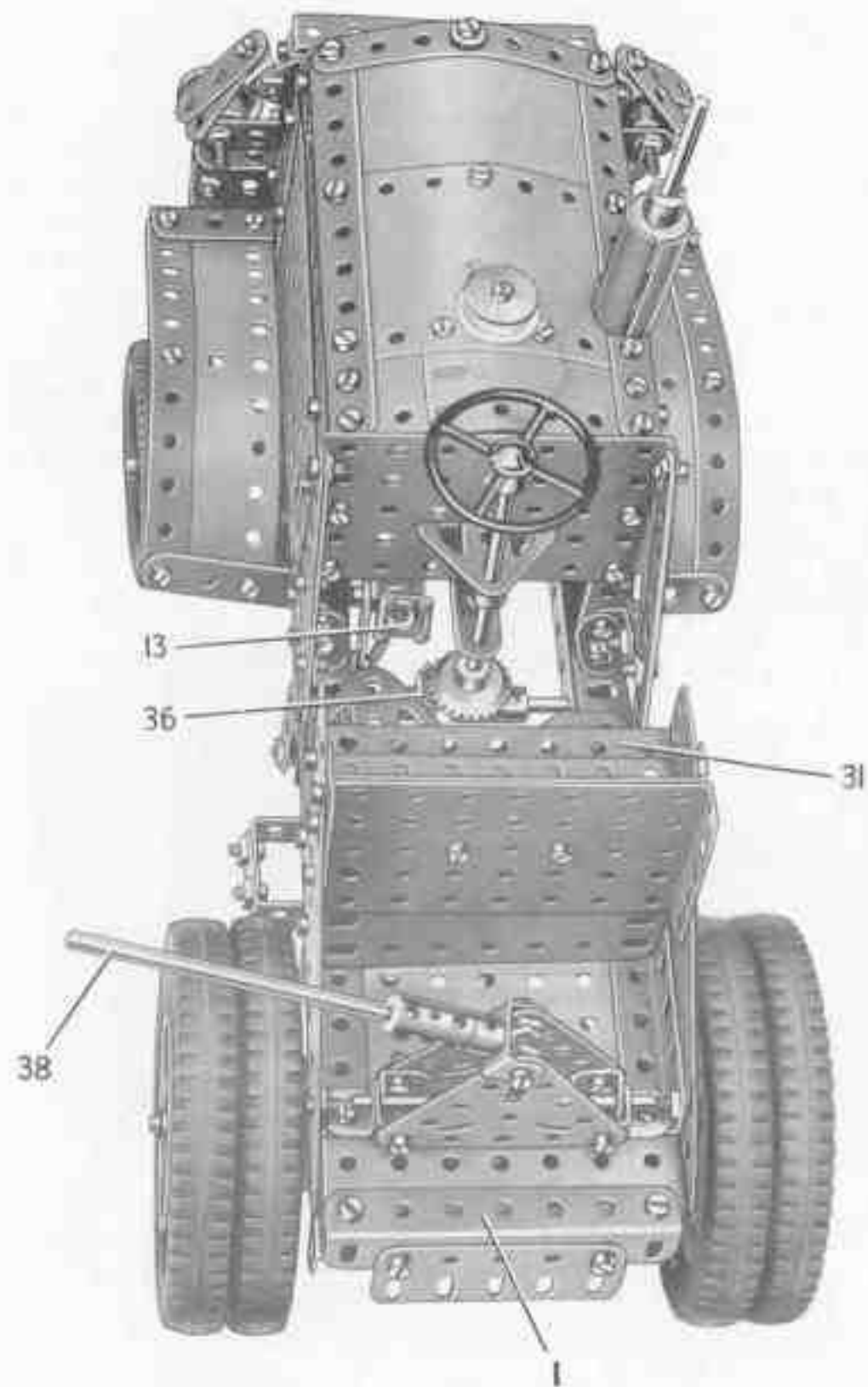

FIG. 5  
Details of the bonnet and bodywork of the power unit

The completed axle is connected by two Angle Brackets to each of the rear springs (see Fig. 7). These are each made from two  $3\frac{1}{2}$ " Strips and a  $2\frac{1}{2}$ " Strip and are attached to the chassis by  $\frac{1}{2}$ " Bolts, each of which is fitted with an Angle Bracket. The rear ends of the springs are spaced from the chassis by four Washers on each Bolt.

**The Bonnet and Bodywork (Figs. 1, 2 and 5)**

Each side of the bonnet is a  $5\frac{1}{2}$ "  $\times$   $2\frac{1}{2}$ " Flat Plate extended by a  $5\frac{1}{2}$ " Flat Girder. The two sides are connected at the front by a  $3\frac{1}{2}$ "  $\times$   $2\frac{1}{2}$ " Flanged Plate extended as shown in Fig. 1 by a  $3\frac{1}{2}$ " Flat Girder, to which two 2" Strips are bolted at an angle. At the back a  $3\frac{1}{2}$ "  $\times$   $2\frac{1}{2}$ " Flanged Plate is connected to the sides by Angle Brackets, and a  $3\frac{1}{2}$ "  $\times$   $1\frac{1}{2}$ " Triangular Flexible Plate is bolted to each flange of the Flanged Plate. The sloping edges of the Triangular Flexible Plates are strengthened by  $3\frac{1}{2}$ " Strips.

The top of the bonnet is filled in by two  $3\frac{1}{2}$ "  $\times$   $2\frac{1}{2}$ " Flexible Plates and two  $2\frac{1}{2}$ "  $\times$   $1\frac{1}{2}$ " Flexible Plates edged by Strips (Fig. 5). The Plates are curved slightly and the assembly is attached to the sides of the bonnet by Obtuse Angle Brackets. A  $\frac{1}{2}$ " Flanged Wheel, capped by a  $\frac{1}{2}$ " Washer, is fixed to the top by means of a  $\frac{1}{2}$ " Bolt.

The bonnet and radiator assembly is attached to the chassis members by Angle Brackets. The exhaust pipe is represented by a 5" Rod fixed in a Collar screwed on to a bolt passed through a flange of the Electric Motor (Fig. 2). This Rod passes through the top of the bonnet, and on it is placed a Sleeve Piece fitted with a Chimney Adaptor and a  $\frac{1}{2}$ " Washer. These parts are held on the Rod by the half of the Dog Clutch left over from the construction of the gear-box.

The radiator guard is a  $3\frac{1}{2}$ "  $\times$   $2\frac{1}{2}$ " Flanged Plate fitted at the top with a  $3\frac{1}{2}$ "  $\times$   $\frac{1}{2}$ " Double Angle

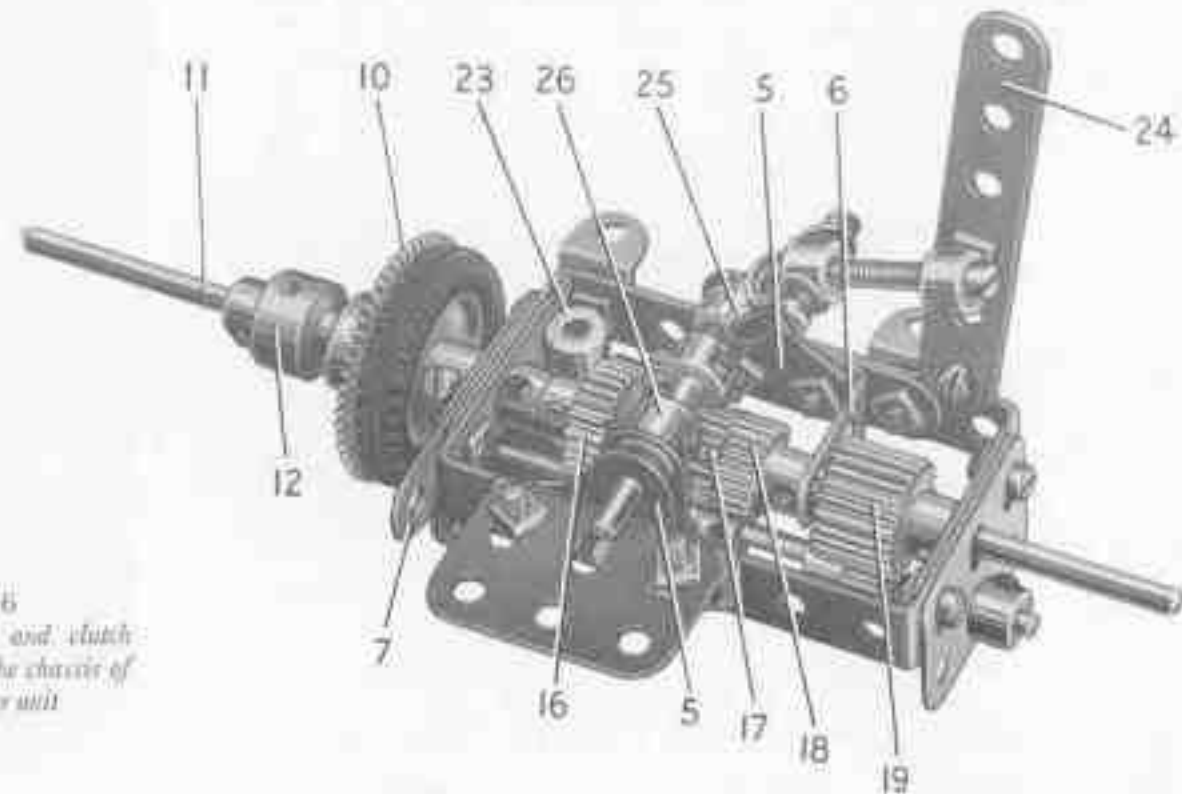

FIG. 6  
The gear-box and clutch removed from the chassis of the power unit



Strip. The headlamps are 1" loose Pulleys and Chimney Adaptors fixed by 1½" Bolts to 1" x ½" Angle Brackets. The shield over each headlamp consists of two 1½" Strips bolted to an Angle Bracket, which is fixed to a 1" Triangular Plate that is attached to the Flanged Plate. The Flanged Plate is supported by Angle Brackets fixed to the chassis.

The driver's seat is formed by two 3½" x 2½" Flanged Plates placed back to back and extended by a 3½" x 2½" Flexible Plate (see Fig. 5). A 3" x 1½" Flat Plate and a 3½" x 2½" Triangular Flexible Plate are bolted to each side as shown (Fig. 2), and these parts are fastened to 3½" Angle Girders fixed to the chassis. A 3½" Angle Girder (31) (Fig. 5) is connected to the Flat Plates by Angle Brackets, and a 3½" Flat Girder behind Girder (31) is supported by a 1½" Angle Girder bolted to the Flanged Plates.

**Assembly of the Steering Mechanism (Figs. 2, 4, 5 and 7)**

The front axle beam (see Fig. 2) consists of three 3½" Strips with a Crank (32) fixed at each end with the boss holes of the Cranks overhanging the ends of the Strips. Each Crank is strengthened by a 2" Strip. The axle beam is attached to springs, each of which consists of three 3½" Strips and a 2½" Strip, and is fitted at each end with a Double Bracket. These Double Brackets are lock-nutted to further Double Brackets fixed to the chassis (see Figs. 2 and 7).

Each of the front wheels (see Figs. 4 and 7) consists of two 2" Pulleys clamped together by four ½" Bolts that fix a Wheel Disc to the face of the outer Pulley. The wheel is mounted freely on a 1½" Rod held in a Coupling (33). These Couplings are fixed on 1" Rods that are free to turn in the Cranks (32) and are

held in place by Collars. Another 1" Rod is fixed in one of the Couplings (33) and is fitted with a Swivel Bearing (34). The latter is connected by a 2½" Rod to a second Swivel Bearing on a 1½" Rod held in the other Coupling (33). The 1½" Rod carries another Coupling (35).

The steering column is a 4½" Rod supported in a Trunnion and a 1" x 1" Angle Bracket bolted to the back of the bonnet (Fig. 5). The Rod carries a ½" Bevel Gear, and its lower end enters the centre hole of a Coupling mounted

freely on a 3½" Rod that carries a ½" Bevel Gear (36). The Rod is fitted also with a Crank (37) (Fig. 7), and is held in the chassis side-members by a Collar. An Angle Bracket is lock-nutted to Crank (37) and to the Angle Bracket in turn is lock-nutted an End Bearing fitted with a 2½" Rod. This Rod is connected by a swivel bearing to a 2" Rod fixed in the Coupling (35). The swivel bearing is obtained from a Universal Coupling.

A protection plate is arranged underneath the steering mechanism as shown in Fig. 4. The plate is attached to the Girder (3) (Fig. 2) by Obtuse Angle Brackets, and is supported by a 1" Reversed Angle Bracket bolted to the axle beam.

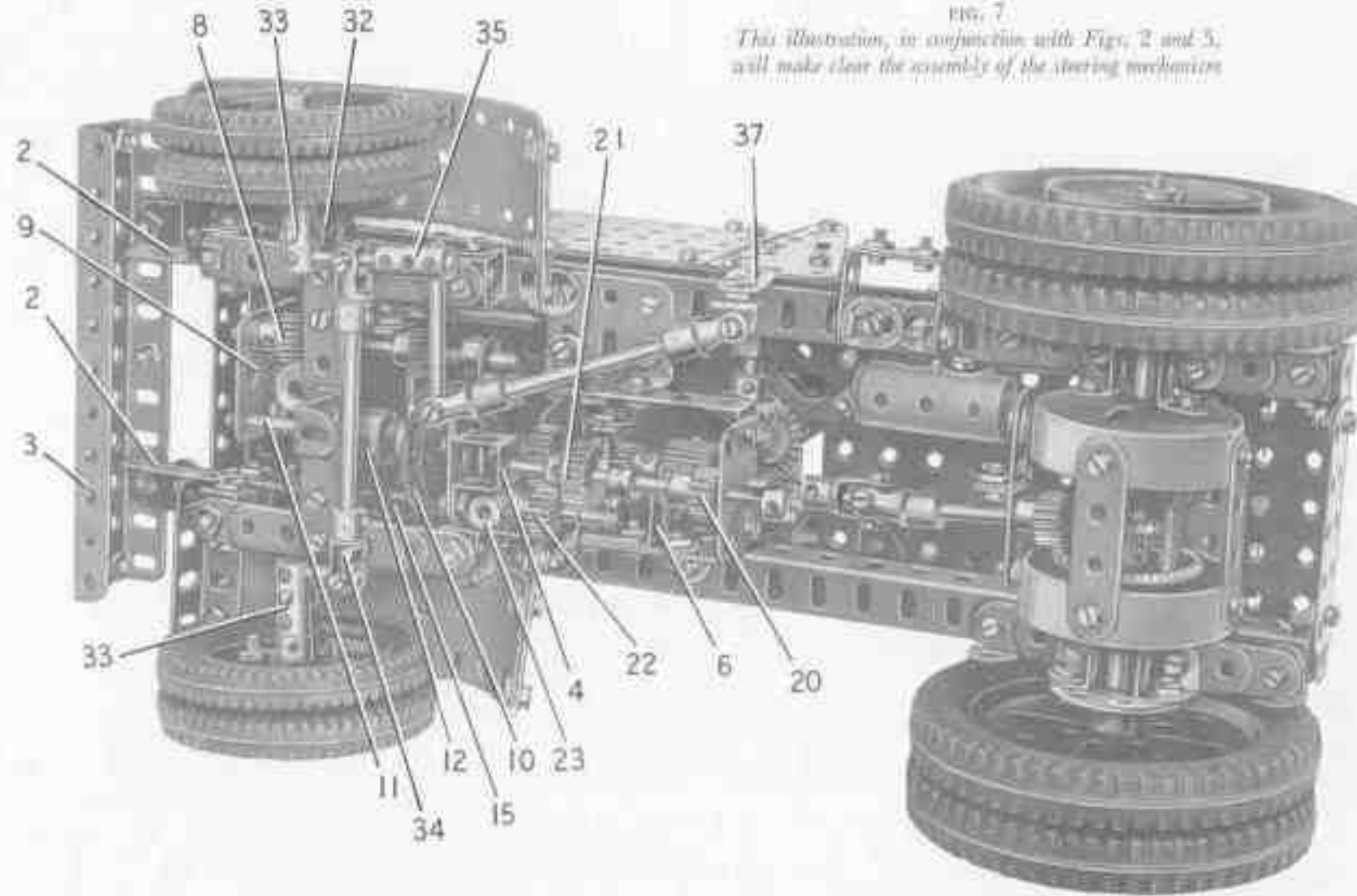

FIG. 7  
This illustration, in conjunction with Figs. 2 and 5, will make clear the assembly of the steering mechanism

**The Coupling Pivot for the Dumper (Fig. 5)**

A 4½" Rod (38), fitted with a Coupling, is fixed in a large Fork Piece lock-nutted to two 2½" Triangular Plates. One of the Triangular Plates is fitted with a 2½" x ½" Double Angle Strip, and the other carries two Angle Brackets. A 3" Rod passed through the logs of the Double Angle Strip and through the Angle Brackets is mounted in further Angle Brackets bolted to the chassis.

### Construction of the Dumper: The Body (Figs. 8 and 9)

Each side of the dumper body is formed with three  $12\frac{1}{2}'' \times 2\frac{1}{4}''$  Strip Plates, two  $9\frac{1}{2}'' \times 2\frac{1}{4}''$  Strip Plates, a  $5\frac{1}{2}'' \times 1\frac{1}{4}''$  Flexible Plate (39) (Fig. 8) and a  $3\frac{1}{2}'' \times 2''$  Triangular Flexible Plate (40). These Plates are bolted together as shown in Figs. 8 and 9, and are edged along the top by a girder (41), made from an  $18\frac{1}{2}''$  Angle Girder and a  $3''$  Angle Girder. A girder (42), made from a  $5\frac{1}{2}''$  Angle Girder and a  $2''$  Angle Girder, is bolted along the front edge of each side and is connected to a  $24\frac{1}{2}''$  Angle Girder (43) by an Obtuse Angle Bracket. The side is strengthened by two  $5\frac{1}{2}''$  Strips (44), a  $3''$  Strip (45) and a built-up strip (46), the lower ends of these Strips being bolted to the Girder (43). The strip (46) consists of a  $5\frac{1}{2}''$  and a  $3''$  Strip.

The front end of the body consists of two  $5\frac{1}{2}'' \times 3\frac{1}{2}''$  Flat Plates and two  $5\frac{1}{2}'' \times 1\frac{1}{2}''$  Flexible Plates. These are bolted together and are strengthened by a  $3\frac{1}{2}'' \times \frac{1}{2}''$  Double Angle Strip fixed between the front ends of the Girders (43), a  $4\frac{1}{2}''$  Strip (47) and a  $7\frac{1}{2}''$  Angle Girder (48). A  $2''$  Strip on each side is bolted between the upper corner of the  $5\frac{1}{2}'' \times 1\frac{1}{4}''$  Flexible Plate and the top corner of the upper  $5\frac{1}{2}'' \times 3\frac{1}{4}''$  Flat Plate.

Each front corner of the dumper is covered by a  $2\frac{1}{2}'' \times 2''$  Triangular Flexible Plate edged by a  $2\frac{1}{2}''$  Strip and a  $3''$  Strip. These Plates are connected to the upper  $5\frac{1}{2}'' \times 3\frac{1}{4}''$  Flat Plate by Angle Brackets.

The rear end of the body consists of a  $5\frac{1}{2}'' \times 3\frac{1}{4}''$  Flat Plate (49) (Fig. 9)

placed vertically, and bolted to a  $3\frac{1}{2}'' \times \frac{1}{2}''$  Double Angle Strip and a  $7\frac{1}{2}''$  Angle Girder (50). The Double Angle Strip is bolted between the Girders (43), and the Angle Girder (50) is attached to the girders (41) by Angle Brackets. A  $5\frac{1}{2}''$  strip on each side is bolted between the lower corner of the Plate (49) and the next-to-end hole of the Girder (50). A  $2\frac{1}{2}'' \times 2\frac{1}{4}''$  Triangular Flexible Plate on each side is used to fill in the gap between the  $5\frac{1}{2}''$  Strip and the Flat Plate (49). A  $2\frac{1}{2}'' \times 2\frac{1}{4}''$  Flat Plate (51), with a  $2\frac{1}{2}'' \times 1\frac{1}{4}''$  Triangular Flexible Plate bolted to each side of it, is supported by a  $3\frac{1}{2}'' \times \frac{1}{2}''$  Double Angle Strip fixed between the Girders (43).

A  $12\frac{1}{2}''$  Strip extended by a  $9\frac{1}{2}''$  Strip is bolted inside the top edge of each side of the body. The sides are tied together by a  $5\frac{1}{2}''$  Flat Girder and a  $4\frac{1}{2}''$  Flat Girder bolted to two  $5\frac{1}{2}''$  Angle Girders (52). The lower ends of the Angle Girders are fixed to the sides, and their top ends are connected to the girders (41) by Corner Angle Brackets.

The Girders (43) are connected at their rear ends by two  $7\frac{1}{2}''$  Angle Girders bolted together to form a channel girder (53). Two built-up girders, each made from a  $5\frac{1}{2}''$  Angle Girder and a  $1\frac{1}{2}''$  Angle Girder, are attached to the girder (53) by Angle Brackets and also to the Girder (50) by Obtuse Angle Brackets. Two other built-up girders (54) are bolted to the girder (53) and are connected to the Flat Plate (49) by Angle Brackets. Each of the girders (54) consists of a  $3\frac{1}{2}''$  Angle Girder and a  $1\frac{1}{2}''$  Angle Girder.

Each of the dumper wheels is fixed on a  $2''$  Rod mounted in two Trunnions

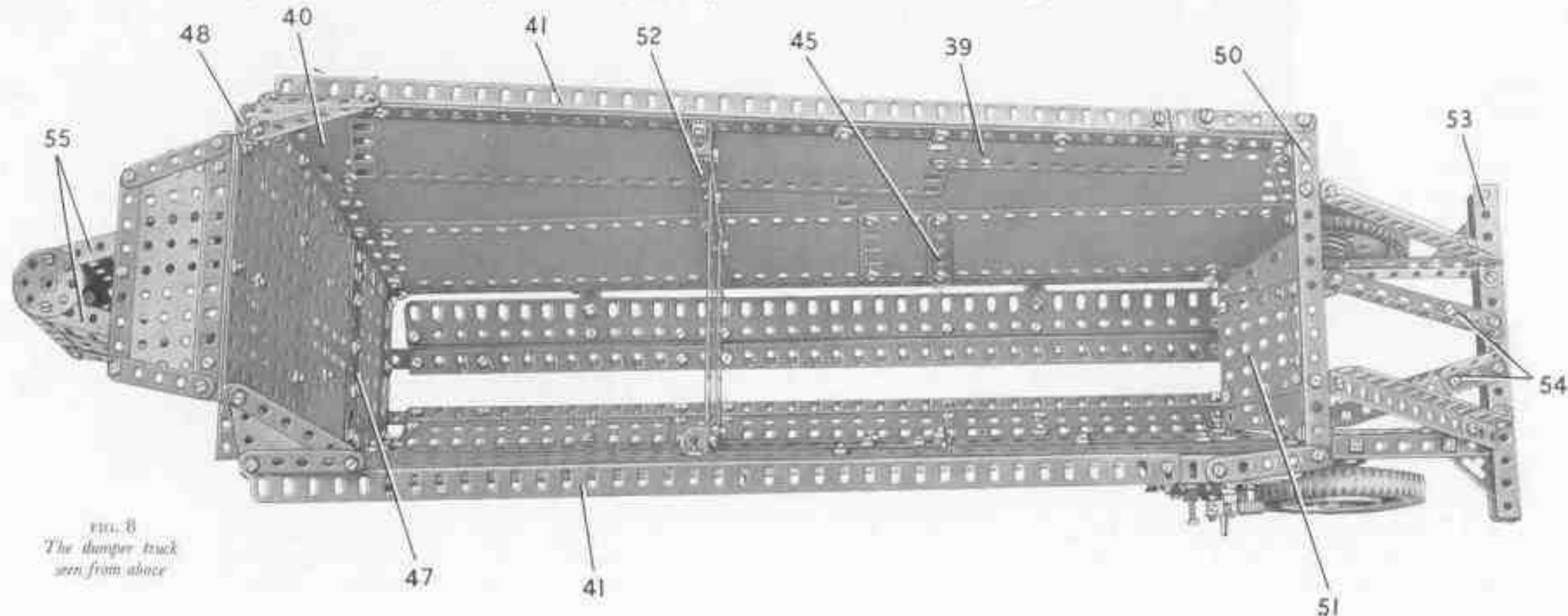

FIG. 8  
The dumper truck  
seen from above



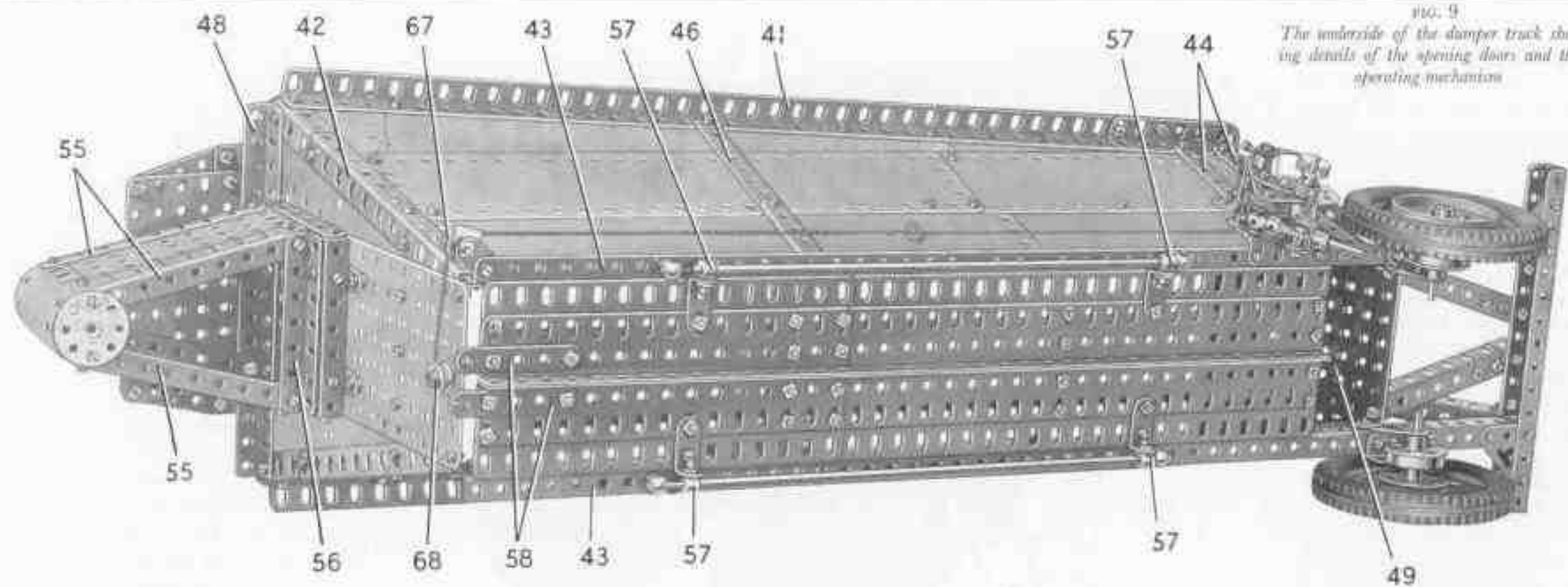

FIG. 9  
The underside of the dumper track showing details of the opening doors and their operating mechanism

bolted to one of the Girders (43). The Rod is held in place by a  $1\frac{1}{4}$ " Pulley and a  $1\frac{1}{4}$ " Flanged Wheel.

The supporting bracket for the coupling unit consists of a  $4\frac{1}{2}$ " x  $2\frac{1}{2}$ " Flat Plate on each side edged by two  $4\frac{1}{2}$ " Angle Girders (55). The upper pair of Girders (55) is bolted to the Girder (48) and the lower pair is attached to a  $3\frac{1}{2}$ " Angle Girder (56). The Girder (56) is connected to the front of the body by two  $\frac{1}{2}$ " Reversed Angle Brackets, each of which is spaced from the body by two Washers. A  $3\frac{1}{2}$ " x  $\frac{1}{2}$ " Double Angle Strip is bolted to the remaining face of the  $\frac{1}{2}$ " Reversed Angle Brackets, and to each lug of this Double Angle Strip a  $2\frac{1}{2}$ " Strip is fixed.

The front ends of the Girders (55) are connected by a U-section Curved Plate and two Bush Wheels, as shown in Figs. 8 and 9. The Rod (38) (see Fig. 5) of the motor unit passes through the Bush Wheels to form the coupling between the motor and the dumper.

#### The Dumper Doors and Operating Mechanism (Figs. 8, 9 and 10)

The floor of the dumper takes the form of two opening doors each made from two  $12\frac{1}{2}$ " Flat Girders, two  $7\frac{1}{2}$ " Flat Girders and an  $18\frac{1}{2}$ " Angle Girder, arranged as shown in Figs. 8 and 9. Two  $1" \times \frac{1}{2}"$  Angle Brackets are bolted to each door, and a bolt is fitted with a nut and then is passed through each Angle Bracket. Two Collars (57) are screwed tightly on to the bolts and then an  $11\frac{1}{2}"$  Rod is pushed through them. The Rods are supported in Handrail Supports

fixed to the Girders (43). A  $2\frac{1}{2}"$  Strip (58) is bolted to each door.

The dumper is fitted with special mechanism for opening and closing the bottom doors. They are opened for dumping the load by moving a handle that releases a ratchet device and allows them to drop downwards. After dumping is completed another lever is moved and the dumper is set in motion. As it moves slowly forward, the special mechanism comes into action and closes the doors automatically.

The arrangement of this mechanism, which can be seen in Figs. 1, 9 and 10, is as follows.

A Girder Bracket is bolted to one of the Girders (43) and to it is fixed a  $\frac{1}{2}"$  Reversed Angle Bracket to which are bolted a  $2\frac{1}{2}"$  Strip (59) (Fig. 10) and two  $1\frac{1}{2}"$  Strips (60). A second  $2\frac{1}{2}"$  Strip is fixed to the Girder Bracket and is connected to Strip (59) by an Angle Bracket and a  $1"$  Reversed Angle Bracket. The  $1"$  Reversed Angle Bracket is bolted to the side of the dumper body (Fig. 9). Two  $3"$  Strips are connected at their lower ends by a large Fork Piece (61), which is attached to one Strip by a lock-nutted  $\frac{3}{16}"$  bolt and to the other Strip by a lock-nutted  $\frac{1}{4}"$  Bolt (62). The  $3"$  Strips pivot on a  $2"$  Rod, which is held in the Strips (60) and the Girder Bracket by a  $\frac{1}{2}"$  fixed Pulley and a  $\frac{1}{2}"$  Pinion. A  $1"$  Rod is mounted freely in the top holes of the  $3"$  Strips and is fitted with a  $\frac{3}{4}"$  Sprocket (63), a 57-tooth Gear (64) and a Ratchet Wheel. A Pawl, which is fitted with a  $\frac{1}{2}"$  Bolt (65) to form a release handle, is mounted on a Pivot Bolt held in the Strip (59). The Pawl engages the teeth of the Ratchet and is held against them by a short piece of Spring Cord (66).

The Fork Piece (61) slides on a 2" Rod held in a Handrail Coupling that is mounted freely on a Pivot Bolt fixed in the Girder Bracket. Between the Fork Piece and the Handrail Coupling a Compression Spring is fitted.

One end of a length of Cord is tied to the boss of the Sprocket (63) and its other end is tied to a Washer. Two separate lengths of Cord are also fastened to the Washer, and each of these is led over one of two 1/2" loose Pulleys (67) (Fig. 9), which are mounted on a 3/8" Bolt held in a Fishplate by two nuts. Both Cords are then passed over a 1/2" loose Pulley (68), and each is tied to one of the Strips (59) of the doors. The Fishplate that supports the Pulleys (67) is bolted to one of the Girders (43) and an Angle Bracket on the 3/8" Bolt serves to keep the Cords on the Pulleys.

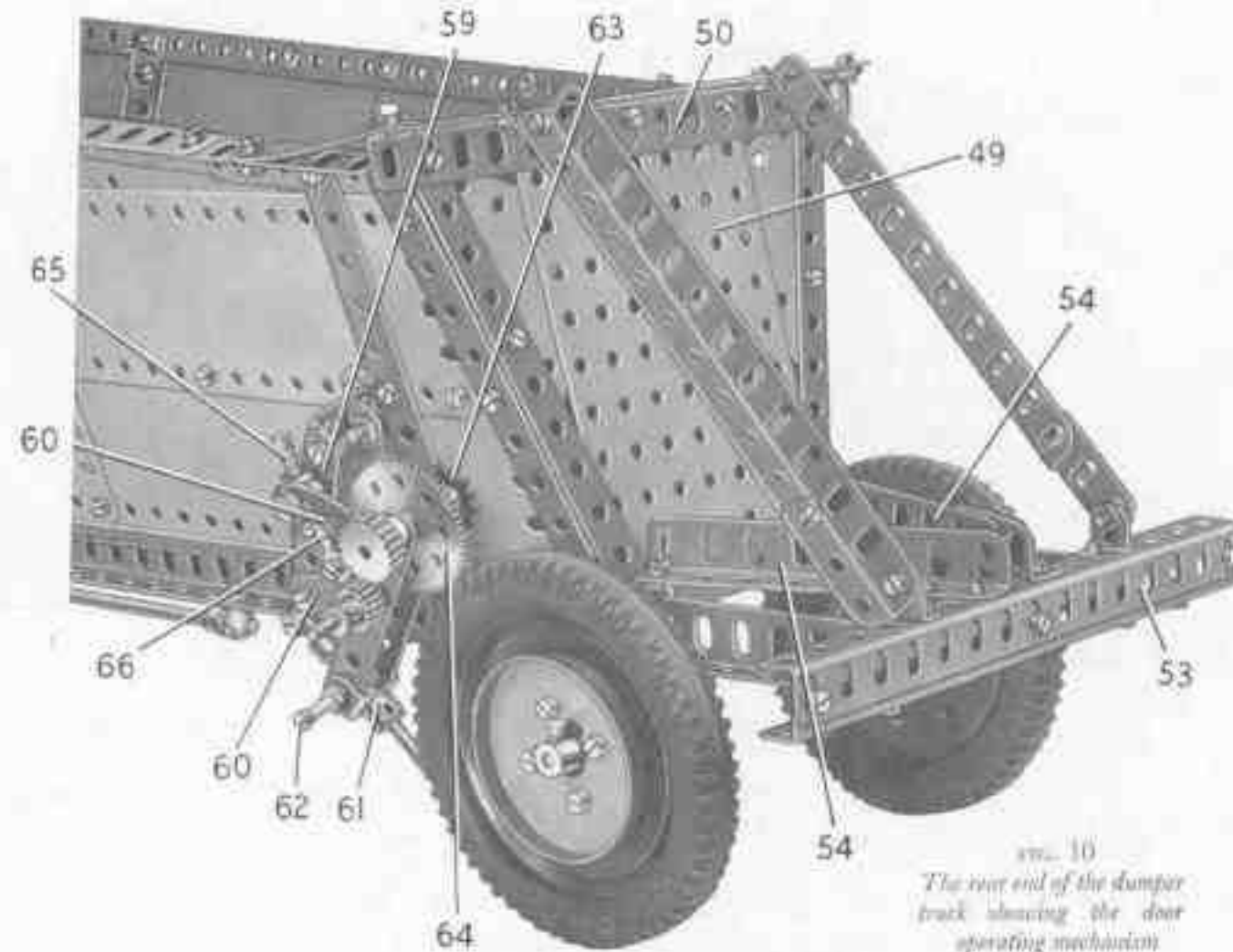

The Pulley (68) is mounted on a Pivot Bolt attached to the front of the body, and is spaced on the Bolt by four Washers.

The doors are closed by moving the Bolt (62) against the action of the Compression Spring until the Gear (64) is pressed against the Tyre of one of the dumper wheels. When the truck is moved forward the Tyre turns the Gear, and thus the Cord is wound round the boss of the Sprocket (63) and the doors are closed. The doors can be opened for unloading the dumper by moving the handle (65) to release the Pawl from the teeth of the Ratchet, so that the Cord unwinds freely from the Sprocket.

A cover over the winding gear is provided by a 2 1/4" x 1 1/2" Flanged Plate and a 2 1/4" x 1 1/2" Triangular Flexible Plate attached to the side of the dumper by an Angle Bracket (Fig. 1).

### Parts Required to Build the Meccano Bottom Dump Truck

2 of No. 1	7 of No. 9b	4 of No. 16	2 of No. 24	58 of No. 38	7 of No. 65	14 of No. 111	1 of No. 136a	4 of No. 164	2 of No. 222
2 - - 1a	2 - - 9c	3 - - 16a	2 - - 24a	2 - - 38d	2 - - 70	2 - - 111a	4 - - 137	2 - - 165	2 - - 223
14 - - 2	2 - - 9d	3 - - 16b	2 - - 24c	1 - - 40	2 - - 72	21 - - 111c	2 - - 140	1 - - 166	2 - - 224
4 - - 2a	4 - - 9e	6 - - 17	4 - - 25	1 - - 45	2 - - 71	3 - - 111d	4 - - 142a	1 - - 171	2 - - 225
18 - - 3	6 - - 9f	6 - - 18a	1 - - 25a	2 - - 47a	2 - - 76	1 - - 115	6 - - 142b	1 - - 179	2 - - 226
10 - - 4	4 - - 10	4 - - 18b	7 - - 26	1 - - 48a	4 - - 77	2 - - 116	1 - - 142c	1 - - 185	
19 - - 5	12 - - 11	6 - - 19b	1 - - 26a	3 - - 48b	2 - - 82	4 - - 120b	1 - - 144	2 - - 188	
12 - - 6	49 - - 12	2 - - 20	2 - - 27a	1 - - 50	1 - - 95a	2 - - 124	1 - - 147	6 - - 189	
8 - - 6a	4 - - 12a	4 - - 20a	1 - - 28	1 - - 51	4 - - 103	3 - - 125	3 - - 147a	1 - - 190	
2 - - 7	8 - - 12b	1 - - 20b	2 - - 29	4 - - 52a	4 - - 103b	5 - - 126	1 - - 148	4 - - 190a	
4 - - 7a	11 - - 12c	2 - - 21	2 - - 30	5 - - 53	2 - - 103c	2 - - 126a	1 - - 154a	4 - - 196	
4 - - 8	2 - - 13	1 - - 22	1 - - 32	3 - - 53a	2 - - 103d	2 - - 128	1 - - 154b	6 - - 197	
4 - - 8b	2 - - 13	2 - - 22a	3 - - 35	1 - - 58	1 - - 103f	2 - - 133	1 - - 161	1 - - 199	
9 - - 9	2 - - 13a	3 - - 23	504 - - 37a	24 - - 59	4 - - 103h	2 - - 133a	2 - - 162a	1 - - 212	
4 - - 9a	1 - - 13b	1 - - 23a	456 - - 37b	4 - - 62	4 - - 103k	4 - - 136	2 - - 163	3 - - 221	

1 E15R  
Electric Motor  
(not included  
in Outfit)