

# MECCANO Lifting Shovel

(MODEL No. 10.6)

## SPECIAL FEATURES

The model represents a popular type of mechanical loading shovel used on large construction jobs where quantities of spoil or other material have to be loaded into vehicles for removal from the site. Power is provided by a Meccano E15R Electric Motor that drives the road wheels through a differential. The lifting and unloading movements of the shovel are controlled from the cab, and the hoisting winch is fitted with an automatic brake.

Among the many labour-saving devices available to modern civil engineers probably few are more useful than the various types of mechanical shovels. These are available in many forms, and the subject of the model described in this Leaflet is a highly manoeuvrable machine known as a Lifting Shovel. The original is powered by a diesel or petrol engine, and is very compact. It is extremely useful for loading spoil or other material from heaps into wagons or trucks, and the model incorporates all the essential features. In building the model it is best to commence with the wheeled chassis, details of which follow.

### Details of the Chassis (Fig. 2, 4, 5 and 8)

Each side-member is made from two  $1\frac{1}{2}$ " Angle Girders joined together by two  $1\frac{1}{2}$ " Flat Girders. They are connected at the rear by a  $4\frac{1}{2}$ "  $\times$   $\frac{1}{2}$ " Double Angle Strip (1) (Fig. 4), and at the front by two  $3\frac{1}{2}$ "  $\times$   $\frac{1}{2}$ " Double Angle Strips (2) (Figs. 2 and 5). To one of the Double Angle Strips (2) a Double Bent Strip (3) is bolted.

Two further  $3\frac{1}{2}$ "  $\times$   $\frac{1}{2}$ " Double Angle Strips (4) are fixed across the chassis and between them a  $2\frac{1}{2}$ "  $\times$   $\frac{1}{2}$ " Double Angle Strip (5) is bolted. Then a  $1\frac{1}{2}$ "  $\times$   $\frac{1}{2}$ " Double Angle Strip is positioned between the Double Angle Strip (5) and the side of the chassis.

A Flat Trunnion is fixed to the  $1\frac{1}{2}$ "  $\times$   $\frac{1}{2}$ " Double Angle Strip, and a similar part is bolted also to each of the Double Angle Strips (4). Two  $3\frac{1}{2}$ "  $\times$   $\frac{1}{2}$ " Double Angle Strips (6) (Figs. 2 and 8) are fixed across the chassis as shown.

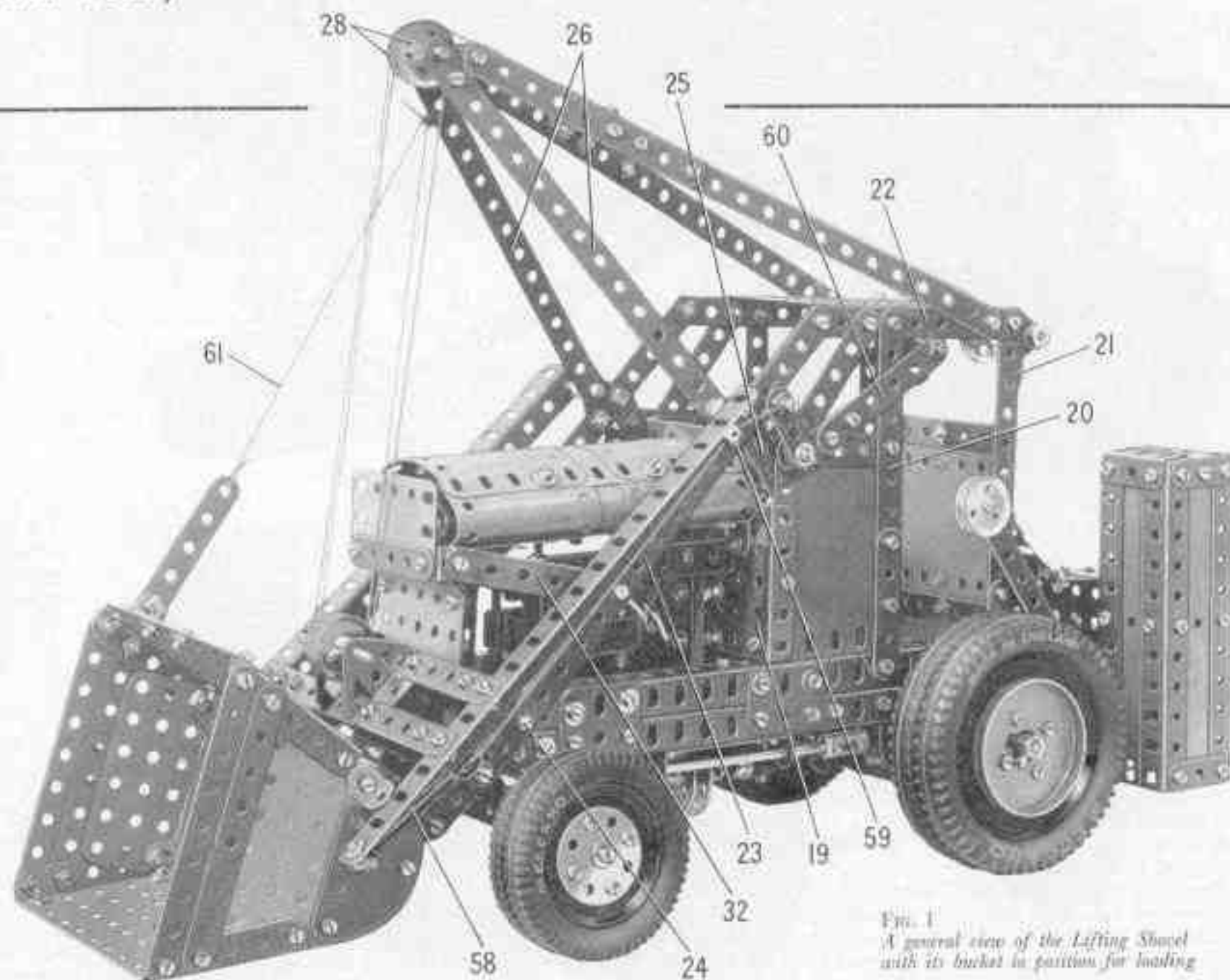

FIG. 1  
A general view of the Lifting Shovel  
with its bucket in position for loading

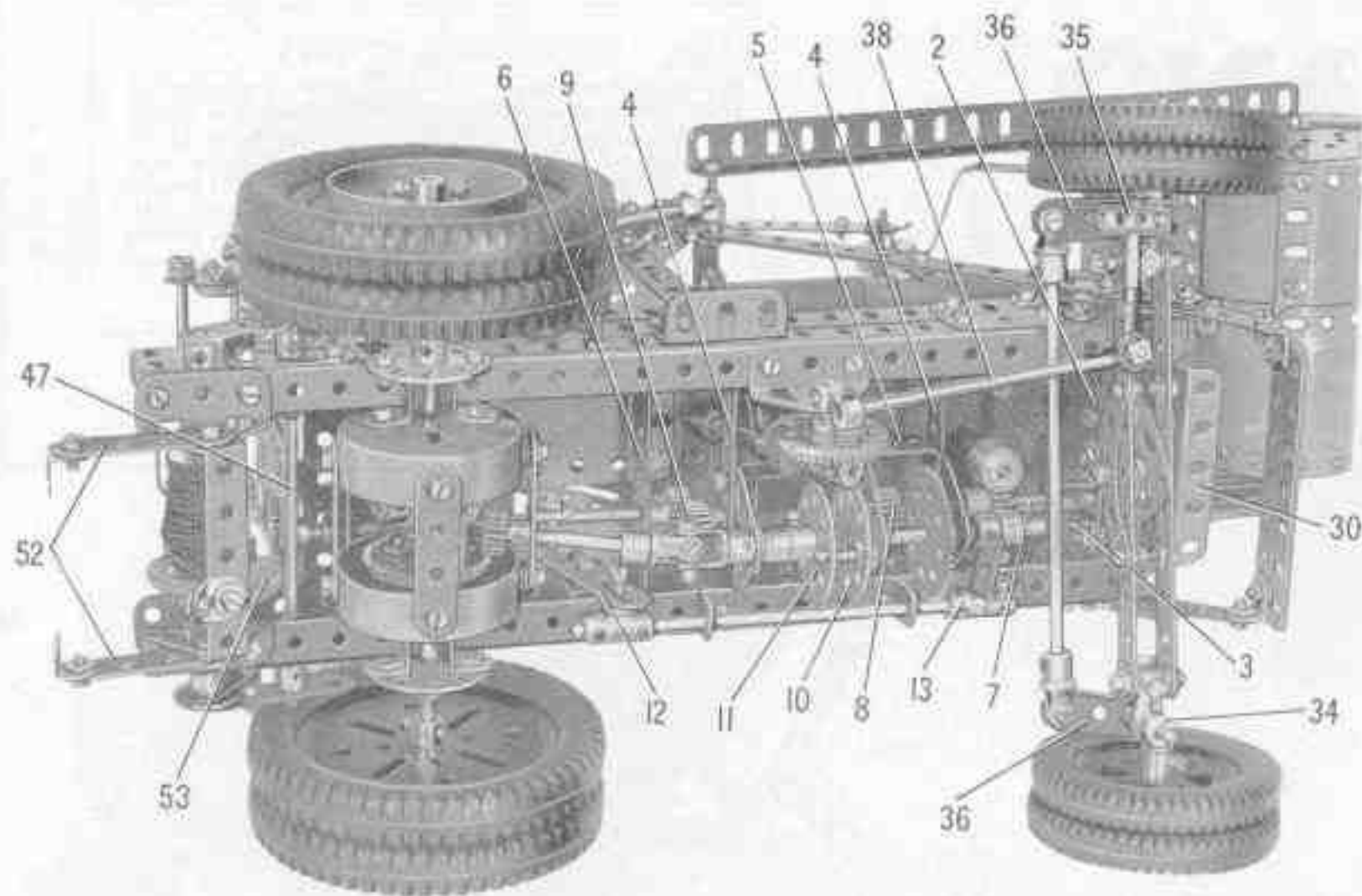

FIG. 2 The Lifting Shaft seen from underneath, with the reduction gearing and the driving mechanism clearly shown

An E15R Electric Motor is attached to the top flanges of the chassis side-members by two Fishplates on each side.

**The Main Drive Gears (Figs. 2, 4 and 5)**

A Worm on the lower end of the Motor armature shaft drives a  $\frac{1}{2}$ " Pinion on a  $4\frac{1}{2}$ " Rod (7). The Rod is supported in the Double Bent Strip (3) and in the Double Angle Strips (4), and it carries two  $\frac{1}{2}$ " Pinions (8 and 9) (Fig. 2). A 57-tooth Gear and a Bush Wheel (10) are fixed on a  $2\frac{1}{2}$ " Rod supported in two of the Flat Trunnions. The Bush Wheel is fitted with two Threaded Pins, and these engage holes in a second Bush Wheel (11), fixed on a  $1\frac{1}{2}$ " Rod mounted in a Crank. The Crank is bolted to the Flat Trunnion fixed to the rear one of the Double Angle Strips (4), and the  $1\frac{1}{2}$ " Rod is held in place by a Universal Coupling.

By sliding the  $2\frac{1}{2}$ " Rod the 57-tooth Gear can be moved into mesh with the Pinion (8). This movement is controlled by a lever (12) (Fig. 4), made from a 3" Strip and a 2" Slotted Strip overlapped two holes. The lever is lock-acted to a Double Bent Strip bolted inside the chassis side-member. A  $\frac{1}{2}$ " Bolt is passed through the slotted hole of the 2" Slotted Strip, and is fixed by a nut in a Coupling on a 3" Rod. This Rod is mounted in a  $2\frac{1}{2}$ " x  $\frac{1}{2}$ " Double Angle Strip bolted to the chassis, and it carries a Coupling (13)

to which a  $1" \times \frac{1}{2}"$  Angle Bracket is attached by means of a  $\frac{1}{4}"$  Bolt. The slotted hole of the Angle Bracket is passed over the  $2\frac{1}{2}"$  Rod as shown (Fig. 5), and a Collar is fixed on each side of it.

**The Rear Axle and Differential (Figs. 2 and 3)**

The rear axle is shown, partly dismantled, in Fig. 3. The axle casing is in two sections, each made by bolting two Double Brackets between a Boiler End and a Bush Wheel (8-holes) (14). When the differential is finally assembled the sections are connected by three 2" Strips and two  $1" \times \frac{1}{2}"$  Angle Brackets (15), each of the latter being spaced from the casing by two Washers on a  $\frac{1}{2}"$  Bolt.

A 4" Rod is passed through one section of the axle casing, and on it a  $1\frac{1}{2}"$  Contrate (16) is free to rotate. A  $\frac{1}{2}"$  Contrate (17) is fixed on the Rod, which is then inserted in a Coupling (18). Two 1" Screwed Rods are held in holes in the Contrate (16) by two nuts each, and Collars are screwed on to the ends of the Screwed Rods. A  $1\frac{1}{2}"$  Rod is fixed in the Collars and in the centre hole of Coupling (18). Two  $\frac{1}{2}"$  Pinions are free to turn on Pivot Bolts screwed into the Coupling. A second  $\frac{1}{2}"$  Contrate is fixed on a  $3\frac{1}{2}"$  Rod supported in the other section of the axle casing.

A 2" Rod is passed through one of the Angle Brackets (15), and a  $\frac{1}{2}"$  Pinion on it engages the Contrate (16). The two  $\frac{1}{2}"$  Contrates mesh with the  $\frac{1}{2}"$  Pinions. Washers are placed on the Rods so that the Pinions and Contrates mesh accurately.

FIG. 3 The differential. One half of the axle casing is removed to reveal the arrangement of the gears

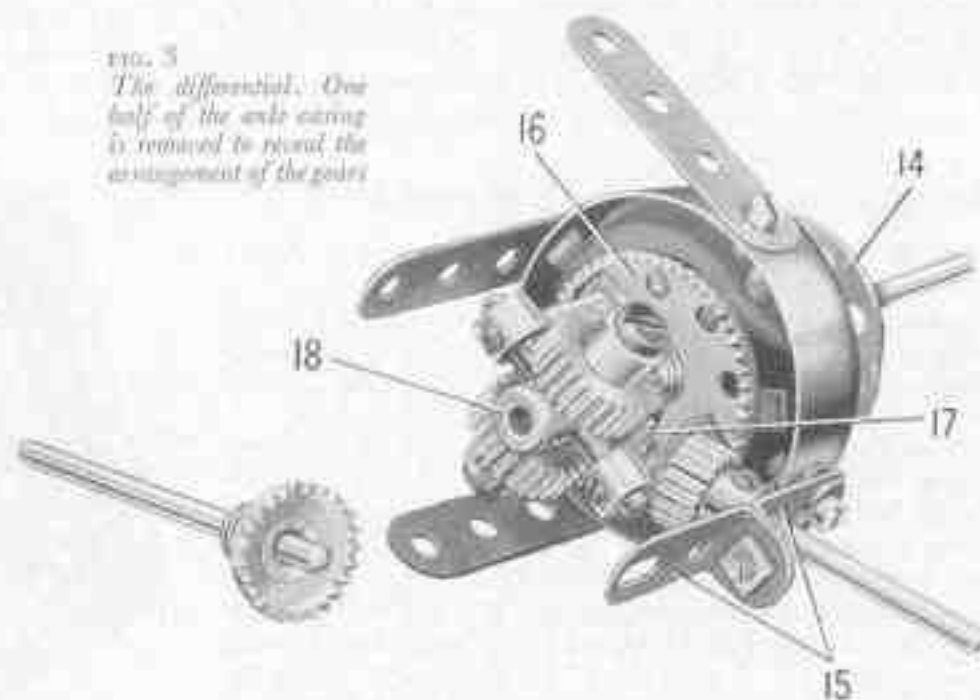



The axle is fitted to the chassis by bolting the Bush Wheels (14) to the side-members. The 2" Rod is fixed in the Universal Coupling on the Rod that carries the Bush Wheel (11).

### Construction of the Cab (Figs. 2, 4, 7 and 8)

The cab front is made by bolting a 3 1/2" x 2 1/2" Flanged Plate (19) (Fig. 1) to a 3 1/2" Angle Girder fixed across the chassis. A 3 1/2" x 2 1/2" Flexible Plate is attached to each flange of the Flanged Plate, and is edged at the top by a 2 1/2" Strip and along its rear edge by a made-up strip (20), formed from a 5 1/2" and a 2 1/2" Strip overlapped four holes.

A 5 1/2" Angle Girder (21) on each side is attached to the chassis by a 1 1/2" Corner Bracket, and the top end of this Girder is connected to the strip (20) by a 4 1/2" Strip (22). A 3" Strip is fixed between the Strip (22) and the top front corner of the 3 1/2" x 2 1/2" Flexible Plate, and a 3 1/2" x 1" Double Angle Strip is bolted between these corners of the Plates on each side.

The Girders (21) are connected together by 3 1/2" Strips and a 3 1/2" x 2 1/2" Flexible Plate as shown (Fig. 8). The floor of the cab is made from a 3 1/2" x 2 1/2" Flexible Plate and a 2 1/2" x 1 1/2" Flexible Plate (Fig. 4). The cab roof is a 3 1/2" x 2 1/2" Flanged Plate, to which two 3 1/2" Strips are attached by means of two 2" Strips.

### Details of the Jib (Figs. 1, 4 and 7)

Two 9 1/2" Strips (23) placed face to face, are bolted between the front of the Strip (22) and the chassis on each side. Their lower ends are extended two clear holes by a 2 1/2" Strip. A 1" Bolt (24) is used to connect the Strips (23) to the chassis, and a nut is placed on the Bolt to space the Strips from the chassis. The lower ends of the 2 1/2" Strips are connected by Angle Brackets to two 3 1/2" Flat Girders placed face to face.

A 5 1/2" Strip (25) on each side is bolted to the Strips (23) and is fixed to the chassis by the same bolt that holds the strip (20). A 1" Triangular Plate is attached to the Strips (23) by the same bolt as the Strips (25), and to this Triangular Plate a 7 1/2" Strip (26) is attached. The bolt that secures the Strip (26) is screwed into the Threaded Boss 27 (Fig. 7).

A 1" Corner Bracket is bolted to the top of each of the Strips (26), and this is connected

to the Strip (22) by a built-up strip made from a 7 1/2" and a 4 1/2" Strip overlapped three holes. The assembled strips are joined across by a 1 1/2" Strip supported by Angle Brackets. Two 1" loose Pulleys (28) are mounted between Collars on a 1 1/2" Rod, which is supported in the end holes of the Strips (26).

Two 1 1/2" Angle Girders are bolted to the back of the cab and each of them supports a 1" Triangular Plate. A 3" Rod held in the Triangular Plates by Collars carries a 1" Pulley (29) (Fig. 8).

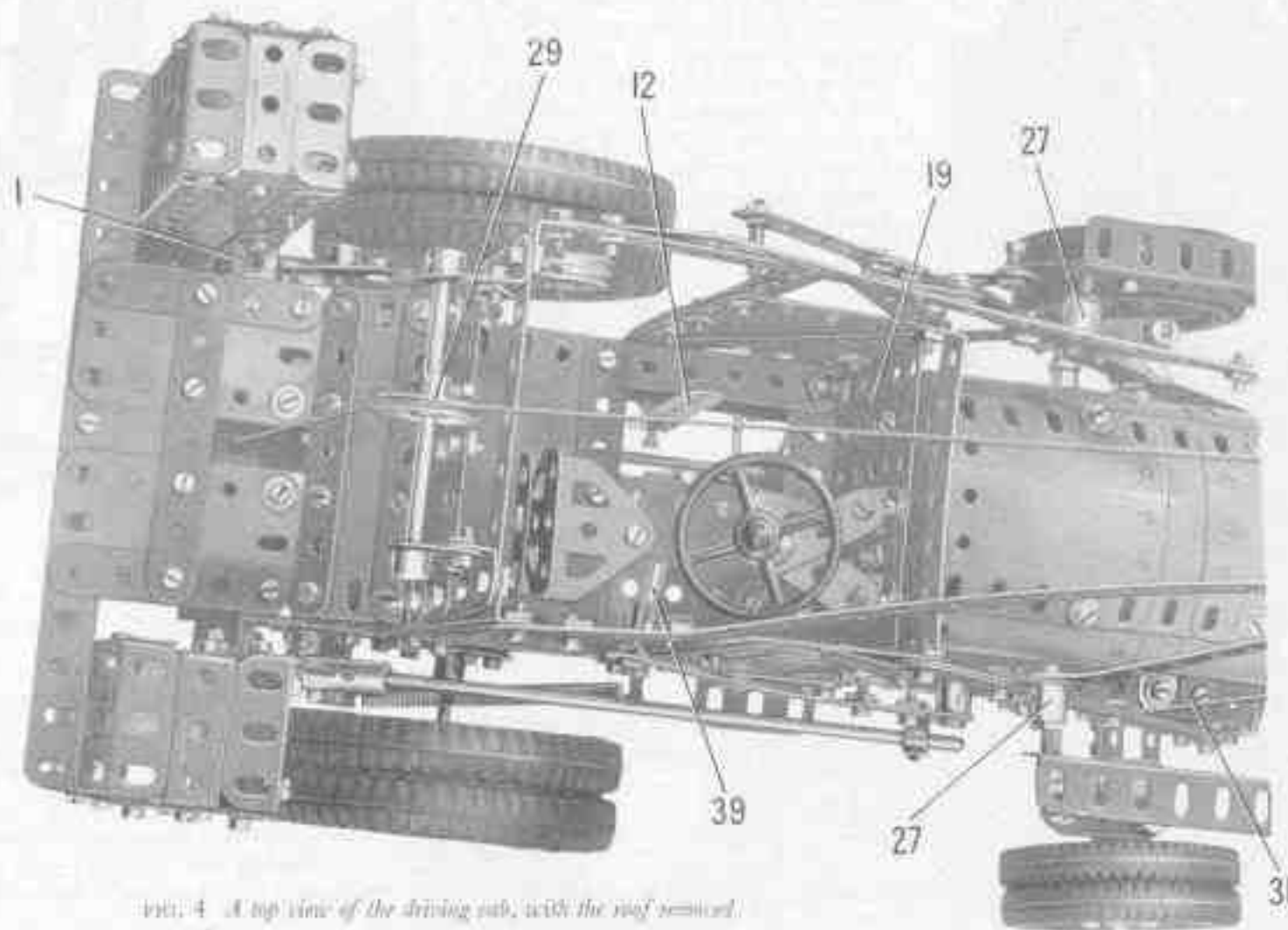

FIG. 4. A top view of the driving cab, with the roof removed.

### Assembly of the Bonnet and Radiator (Figs. 1, 2, 4 and 7)

The bonnet consists of two 1 3/8" radius Curved Plates that overlap a similar Plate at the centre by two holes each. Each side consists of three U-section Curved Plates, and the front pair of these is connected by a 2 1/2" x 1 1/2" Flexible Plate. A 2 1/2" Stepped Curved Strip is bolted to a 2 1/2" Strip attached to the 2 1/2" x 1 1/2" Flexible Plate by an Angle Bracket. The rear end of the bonnet is supported by Angle Brackets bolted to the Flanged Plate (19).

The radiator is made by bolting a 3 1/2" x 2 1/2" Flanged Plate (30) to the front edge of the 2 1/2" x 1 1/2" Flexible Plate. The Flanged Plate is supported by 1/2" Corner Angle Brackets (31) fixed to the chassis, and a 2 1/2" x 2 1/2" Flat Plate is attached to the Flanged Plate by 7" Bolts, but is spaced from it by nuts. Two 1/2" Reversed Angle Brackets are fixed to the top of the 2 1/2" x 2 1/2" Flat Plate and these support a 2 1/2" Strip and a 2 1/2" x 1 1/2" Flexible Plate. A 3" Strip (32) on each side is bolted to the Strip (23) and is connected to one of the 1/2" Reversed Angle Brackets by an Angle Bracket.

### Front Axle and Steering Mechanism (Figs. 2, 4, 5 and 7)

The front axle beam, which is pivoted, consists of two 5 1/2" Strips, with a Coupling (33) (Fig. 5) fixed between them at each end. The Coupling is attached to each Strip by a bolt, which carries a Washer and passes through the lug of a Double Bracket and through an end hole of the Strip. A second Washer is placed on the bolt and it is then screwed tightly into the Coupling. A 1/2" Bolt is passed through the centre portion of the Double Bracket and a Washer is placed on it before it enters the Coupling. A nut is screwed tightly on the Bolt to fix the Coupling and the Double Bracket firmly together.

A 2 1/2" Stepped Curved Strip is bolted to each 5 1/2" Strip of the axle beam, and a 1" Bolt is passed through them and through the centre holes of Flat Trunnions bolted to

Double Angle Strips (2). A Collar and three Washers are placed on the Bolt between the Flat Trunnions, and the Bolt is fitted with *lock-nuts* to allow the axle beam to pivot freely.

A  $1\frac{1}{2}$ " Bolt carrying two Washers is passed through the bosses of each pair of front wheels and another Washer is placed on the Bolt. One Bolt is then screwed into a Collar (34) and the other is screwed into a Coupling (35). The Collar and the Coupling are fixed on  $1\frac{1}{2}$ " Rods, which are mounted in the Couplings (33). A Crank (36) on each Rod is spaced from the Coupling (33) by two Washers. An End Bearing is *lock-nutted* to each Crank, the End Bearings afterwards being linked together by a 5" Rod.

The steering column is a 5" Rod passed through the  $3\frac{1}{2}$ " Angle Girder that supports the Flanged Plate (19). At its upper end the Rod is supported in holes in two  $1\frac{1}{2}$ " Strips, each of which is connected to the Flanged Plate (19) by an Obtuse Angle Bracket (Fig. 4).

The lower end of the Rod is supported in a Coupling (37) (Fig. 5) which is fixed on a 1" Rod and is spaced from a  $1\frac{1}{2}$ " Contrace by three Washers. The Contrace is free to turn on the Rod, which is then held by a Collar in a Trunnion bolted to the chassis. A  $\frac{1}{2}$ " Pinion on the steering column engages the Contrace.

A  $\frac{1}{2}$ " Bolt is passed through a hole in the Contrace, it fitted with two Washers and a nut, and is then fixed in a Collar on a  $3\frac{1}{2}$ " Rod (38). A Rod and Strip Connector on the other end of Rod (38) is *lock-nutted* to another Rod and Strip Connector on a  $1\frac{1}{2}$ " Rod. The  $1\frac{1}{2}$ " Rod is fixed as shown in the Coupling (35).

#### The Motor Control Switch (Figs. 4 and 7)

A 1" Rod (39) is gripped in a Handrail Coupling, which is fixed on a  $2\frac{1}{2}$ " Rod passed through the Flanged Plate (19) and held in place by a Collar and a Double Arm Crank (40) (Fig. 7). A 2" Strip is *lock-nutted* to the Double Arm Crank and to an arm of the Motor switch.

#### Arrangement of the Winch (Figs. 2, 6, 7 and 8)

The Pinion (9) drives a  $\frac{1}{2}$ " Pinion on a 5" Rod supported in the Double Angle Strips (6) and held in place by a Collar. The rear end of this Rod carries a  $\frac{1}{2}$ " Bevel (41) that drives a similar Bevel on a  $4\frac{1}{2}$ " Rod (42) (Fig. 8), which is fitted with a

Collar (43). Rod (42) is held in position by two Collars.

The winch drum consists of a Sleeve Piece fitted at one end with a Chimney Adaptor and at the other end with a  $\frac{1}{2}$ " Flanged Wheel. This assembly is fixed on a  $4\frac{1}{2}$ " Rod passed through slotted holes in the chassis and held in place by a Collar at each end. A 1" Pulley (44), fitted with a Rubber Ring, is fixed on the Rod.

The drive to the winch is brought into operation by sliding the  $4\frac{1}{2}$ " Rod upwards in the slotted holes until the Rubber Ring on Pulley (44) presses against the Collar (43). The movement of the Rod is controlled by a Crank (45) (Fig. 8), and a Double Arm Crank (46) extended by a  $1\frac{1}{2}$ " Strip (Fig. 6). These are fixed on a 5" Rod (47) mounted in  $1\frac{1}{2}$ " Strips that are bolted over slotted holes in the chassis. A Double Arm Crank (48) is fixed on Rod (47). The Crank (45) and the Strip bolted to the Double Arm Crank (46), are slipped over the ends of the Rod that carries the winch drum. At one side a balance arm (49) is fitted on the Rod, and is separated from the  $1\frac{1}{2}$ " Strip by two  $\frac{1}{2}$ " Washers. The balance arm consists of a 2" Slotted Strip and a  $3\frac{1}{2}$ " Strip overlapped two holes, and it is held by a Collar at one end of the Rod (42). The top end of the arm is weighted by two 1" loose Pulleys.

The drive to the drum is engaged by operating a lever (50) (Fig. 7). This consists of a  $3\frac{1}{2}$ " Strip bolted to a Bell Crank, which is mounted on a Pivot Bolt attached to one of the Strips (25) by two nuts. A Collar pivots on a bolt passed through the Bell Crank, and is connected by a  $6\frac{1}{2}$ " Rod to a Strip Coupling (51). The latter is pivotally connected to one arm of the Double Arm Crank (48) by a  $\frac{1}{2}$ " Bolt. A Spring is bolted to the other arm of the Double Arm Crank and is attached to the chassis by a Pivot Bolt as shown (Fig. 8).

#### The Balance-weight Boxes and Winch Cover (Figs. 1, 4 and 7)

At the rear of the chassis are two balance-weight boxes, each of which consists of four  $5\frac{1}{2}$ " x  $1\frac{1}{2}$ " Flexible Plates connected by four  $5\frac{1}{2}$ " Angle Girders. The top of each box is filled in by two  $1\frac{1}{2}$ " Angle Girders and a  $1\frac{1}{2}$ " x  $\frac{1}{2}$ " Double Angle Strip. The two boxes are connected by a  $7\frac{1}{2}$ " Angle Girder, a  $5\frac{1}{2}$ " Strip, a  $7\frac{1}{2}$ " Strip and a  $4\frac{1}{2}$ " x  $2\frac{1}{2}$ " Flexible Plate. The boxes themselves are bolted to the lugs of the Double Angle Strip (1).

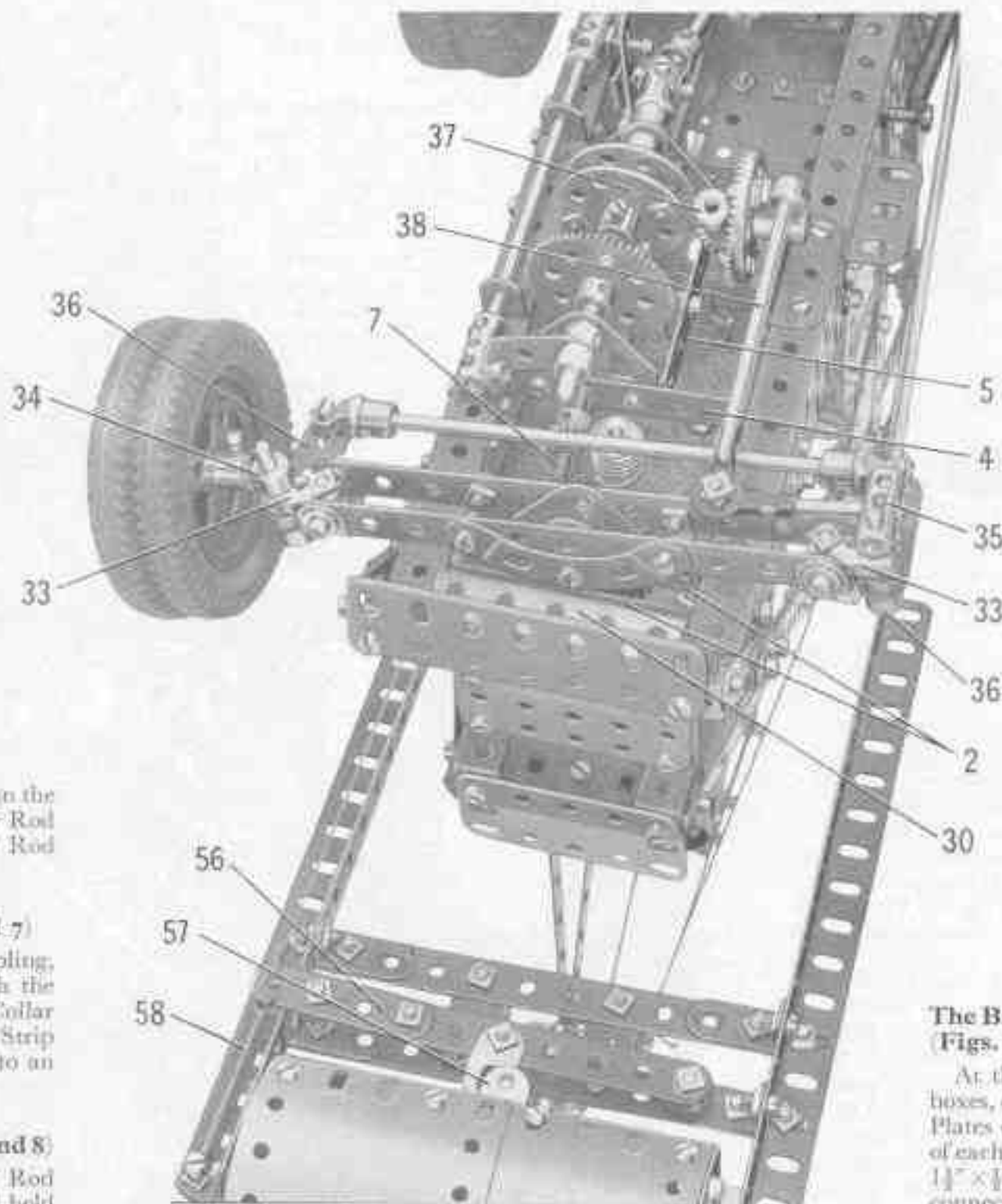

FIG. 5. A front and end view showing the pivoted front axle beam and details of the steering mechanism.



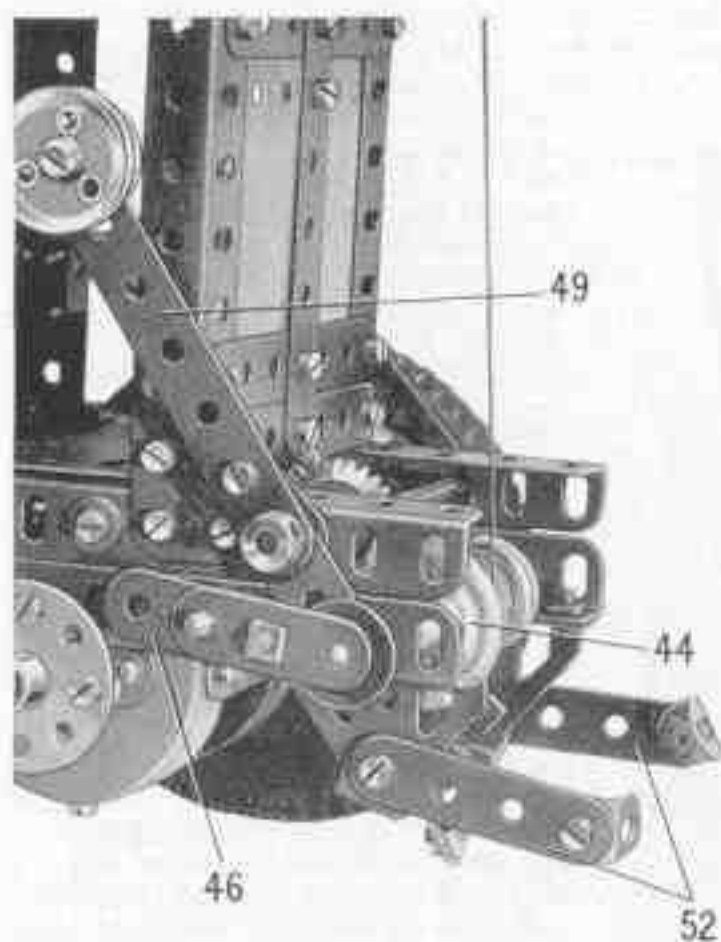

FIG. 6 The balance weight and lever fitted to one end of the winding drum shaft

Two 2" Strips (52) are connected to the 7½" Strip by Angle Brackets, and are bolted to Trunnions fixed to the chassis (Fig. 6). A 2½" × ½" Double Angle Strip is bolted between the Trunnions, and a 2½" Strip (53) is attached to it by an Obtuse Angle Bracket. This Strip is arranged so that the Rubber Ring on Pulley (44) bears against it when the winding drum is pulled by its spring to the lower limits of the slotted holes. This forms an automatic brake that is released when the winding drum is lifted to engage the drive.

A cover over the winding drum mechanism is arranged as shown in Figs. 4 and 7. The cover hangs on Hinges, which are bolted to the back of the cab.

A catch (56) is formed by a 4½" Strip extended one hole by a 2" Strip (Fig. 5). The catch pivots on a ½" Bolt passed through the shovel arm. A 'spider' from a Swivel Bearing is placed on the Bolt, which is then fixed by two nuts in a hole at one end of the catch. A Fishplate bolted to the catch engages an Angle Bracket (57) fixed to the back of the shovel. A Spring (58) (Fig. 1) is fitted between the free end of the catch and one side of the shovel arm.

#### Arrangement of the Cords (Figs. 1 and 7)

The lifting Cord is tied to the winch drum and is taken over the Pulley (29) and one of the Pulleys (28). It is passed round one of the Pulleys (54) of the shovel, round the second Pulley (28) and round the second Pulley (54). The Cord is tied finally to the top of the jib.

FIG. 7

The Loading Shovel seen from the rear. The shovel arm is raised and the shovel is tipped to discharge its load.

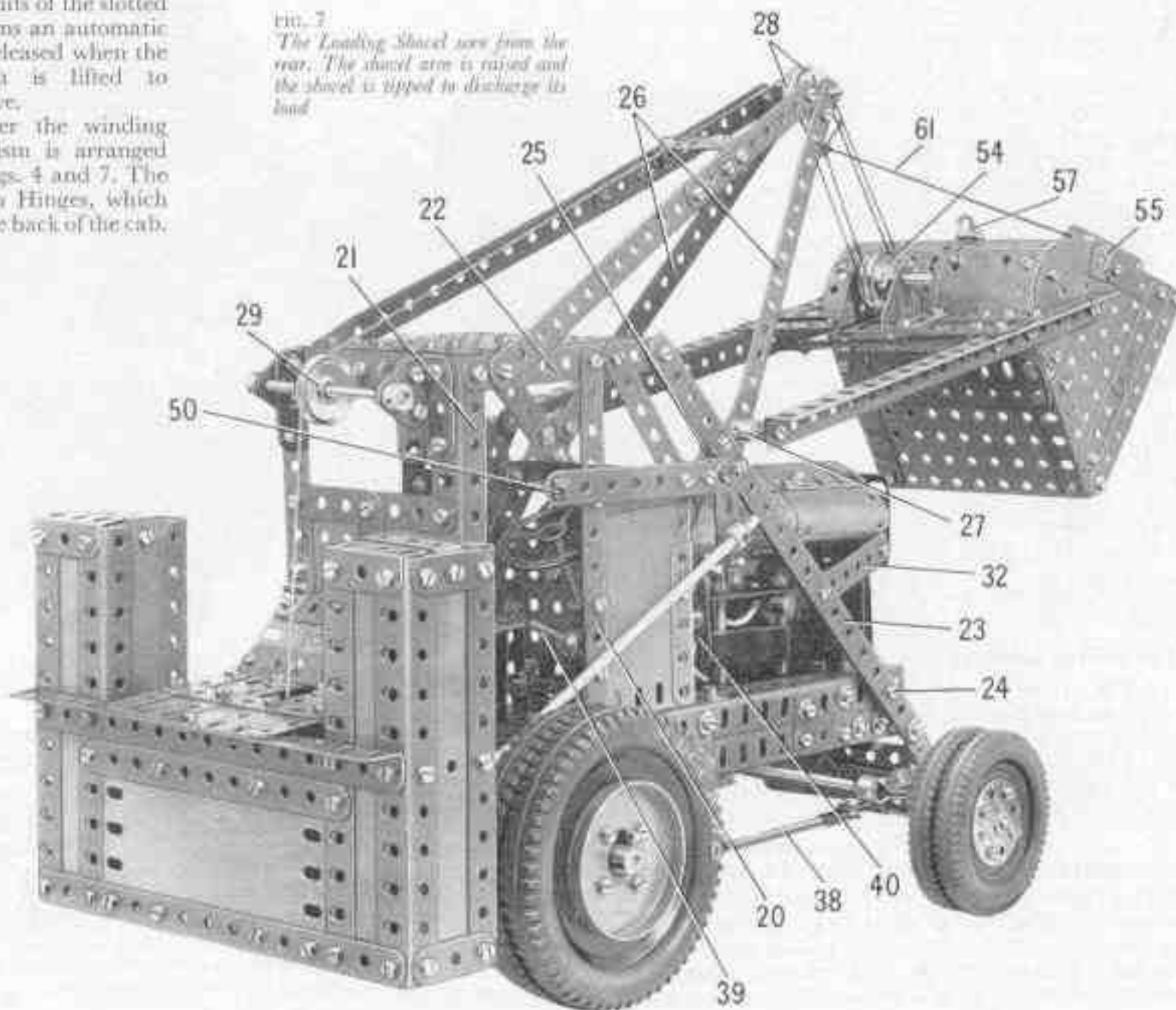

#### Details of the Shovel Arm and Shovel (Figs. 1, 7 and 9)

The shovel arm consists of two 9½" Angle Girders connected by two assembled strips, each made from a 5½" and a 2½" Strip overlapped four holes. The ends of the strips are bolted to 1" × ½" Angle Brackets. Two Trunnions are bolted between the strips and they carry a 2" Rod that bears two 1" Pulleys (54) (Fig. 7). The shovel arm pivots on ½" Bolts, each of which is fixed by a nut in one of the Threaded Bosses (27).

Each side of the shovel is formed by a 3" × 1½" Flat Plate edged by two 2½" Angle Girders, to which are bolted a 4½" Strip and two 2½" Strips. A Semi-Circular Plate is connected to the 3" × 1½" Flat Plate by two Fishplates. The sides are connected by a 4½" × 2½" Flexible Plate and a 4½" × 2½" Flat Plate bolted between the 2½" Angle Girders. Each of these Plates is strengthened at the top by a 4½" Strip, and along its lower edge a 4½" Flat Girder is bolted. Four 1½" radius Curved Plates are bolted to the Flat Girders and are connected to the Semi-Circular Plates by Angle Brackets. A stop (55) (Fig. 9) on each side is formed by an Angle Bracket. These stops control the angle of the shovel when the arm is lowered. The shovel pivots freely on ½" Bolts held by lock-nuts in the Semi-Circular Plates.

FIG. 8  
A close-up of the winding drum and its control lever.

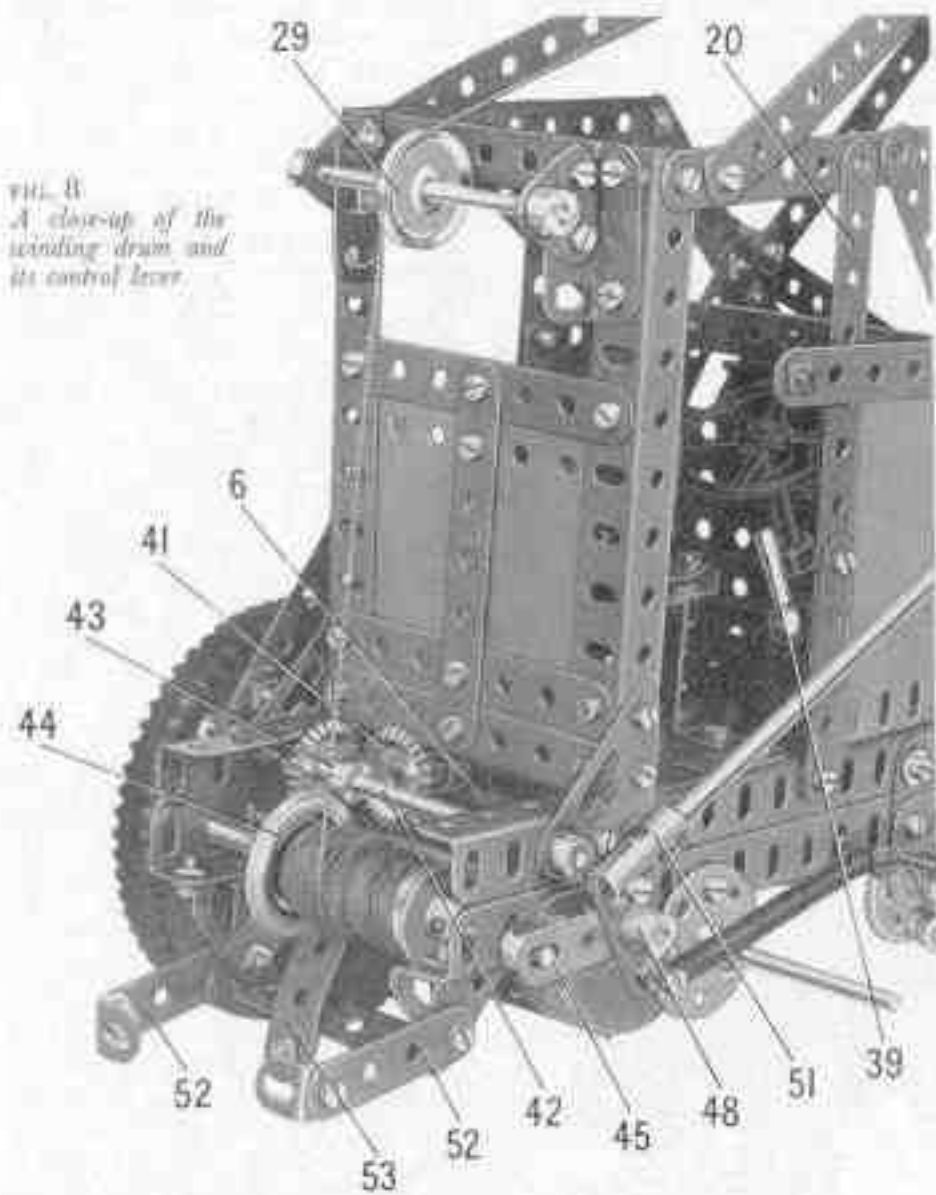

The release Cord for the catch (56) is tied to the free end of the catch lever and is passed through a 'sunder' (59) from a Swivel Bearing, which is screwed on to a bolt fixed by a nut in one side of the shovel arm. Then the Cord is tied to a  $\frac{1}{2}$ " Bolt fixed by nuts in a Bell Crank. The latter is pivoted on a  $\frac{1}{2}$ " Bolt attached to the side of the cab by two nuts. One arm of the Bell Crank is extended by a 3" Strip to form a lever (60). When this lever is pulled downwards the catch (56) is released and the shovel tilts to discharge its contents.

After discharging its contents the shovel is returned to its working angle automatically by a Cord (61) (Fig. 9). This is tied to the top of the jib and to a  $\frac{1}{4}$ " Strip, lock-mitted to an Angle Bracket bolted to the shovel. The length of the Cord (61) is adjusted so that it is taut when the shovel arm is fully lowered and the lower face of the shovel rests on the ground. While in this position the Angle Bracket (57) is adjusted so that it engages the Fishplate of the catch (56).

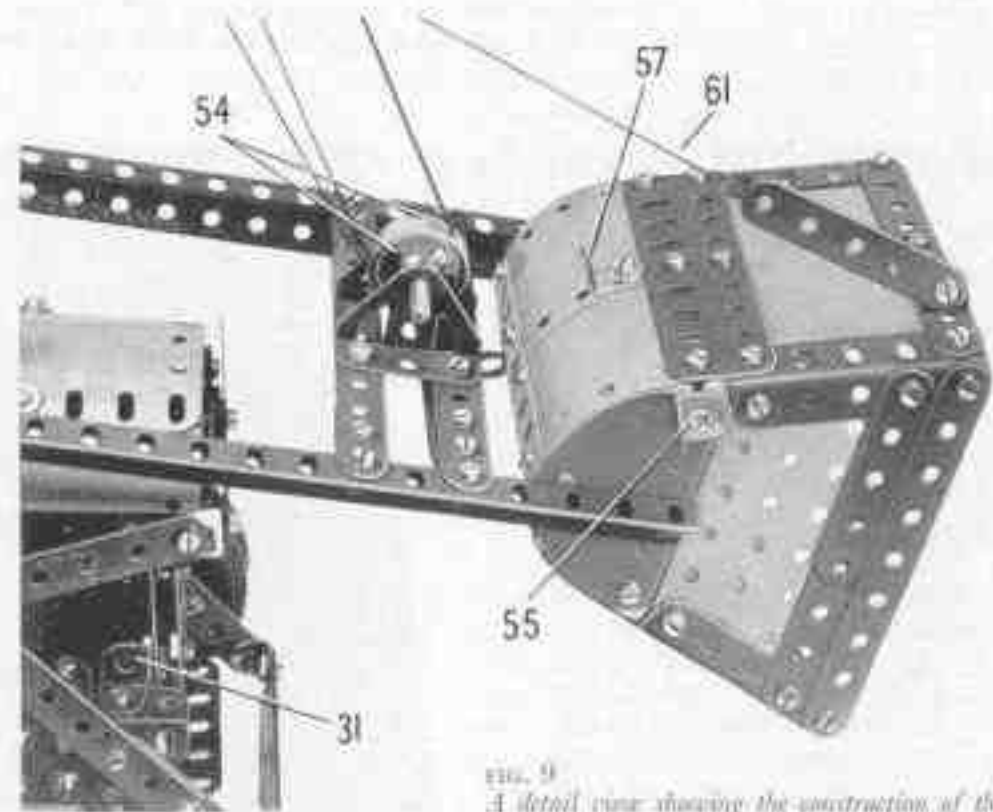

FIG. 9  
A detail view showing the construction of the shovel and the catch that controls the discharging operation.

### How to Operate the Lifting Shovel

First lower the shovel arm and engage the catch (56). Then the machine is ready for driving forward into the material to be moved, in order to load the shovel. Now engage the witch and raise the shovel arm. The shovel is prevented from tilting by the catch (56). The machine can now be travelled to the discharge point, where the lever (60) is depressed to release the catch and so allow the shovel to tilt and discharge its contents.

### Parts required to Build the Meccano Lifting Shovel

4 of No. 1a	10 of No. 9	1 of No. 15b	4 of No. 22a	381 of No. 37b	1 of No. 53a	2 of No. 82	2 of No. 125	4 of No. 147b	4 of No. 190a
5 - - 1b	1 - - 9b	2 - - 16	4 - - 24	85 - - 38	2 - - 55a	3 - - 90a	5 - - 126	1 - - 154a	2 - - 191
9 - - 2	5 - - 9d	2 - - 16a	2 - - 24a	2 - - 38d	24 - - 59	2 - - 103c	7 - - 126a	1 - - 154b	5 - - 199
8 - - 2a	8 - - 9f	1 - - 16b	2 - - 25	1 - - 40	4 - - 62	2 - - 103d	2 - - 128	1 - - 155	7 - - 200
13 - - 3	10 - - 10	2 - - 17	6 - - 26	2 - - 43	3 - - 62b	4 - - 103b	2 - - 133	2 - - 162a	2 - - 212
6 - - 4	6 - - 11	5 - - 18a	1 - - 27a	2 - - 45	7 - - 63	2 - - 111	2 - - 133a	1 - - 163	2 - - 214
18 - - 5	19 - - 12	3 - - 18b	2 - - 28	3 - - 48	1 - - 63b	8 - - 111a	1 - - 136a	1 - - 164	
9 - - 6	7 - - 12b	1 - - 20b	2 - - 29	4 - - 48a	2 - - 64	14 - - 111c	2 - - 137	2 - - 165	
10 - - 6a	7 - - 12c	4 - - 19b	2 - - 30	7 - - 48b	1 - - 72	2 - - 111d	1 - - 140	2 - - 166	
4 - - 8	1 - - 14	4 - - 20a	1 - - 32	1 - - 48c	2 - - 73	2 - - 114	4 - - 142a	1 - - 165	
2 - - 8a	4 - - 15	4 - - 22	421 - - 57a	3 - - 53	4 - - 77	4 - - 115	4 - - 142b	9 - - 168	1 E15R Electric Motor (not included in Outfit).
1 - - 8b	4 - - 15a							8 - - 189	