

MECCANO[®]

**BOOK OF MODELS
VOORBEELDENBOEK
LIVRE DES MODÈLES
LIBRO DEI MODELLI
MODELLBUCH
MODELLBOK
LIBRO DE MODELOS
LIVRO DE MODELOS
MODELLBOK**

5

Complete list of Meccano Parts
 Komplete lijst van Meccano-onderdelen
 Liste complète des pièces Meccano
 Distinta delle componenti del Corredo Meccano
 Vollständige Liste der Meccano-Teile
 Fullständig förteckning över Meccanodelar
 Lista completa de piezas de Meccano
 Lista completa de peças do Meccano
 Komplett liste over Meccanodeler

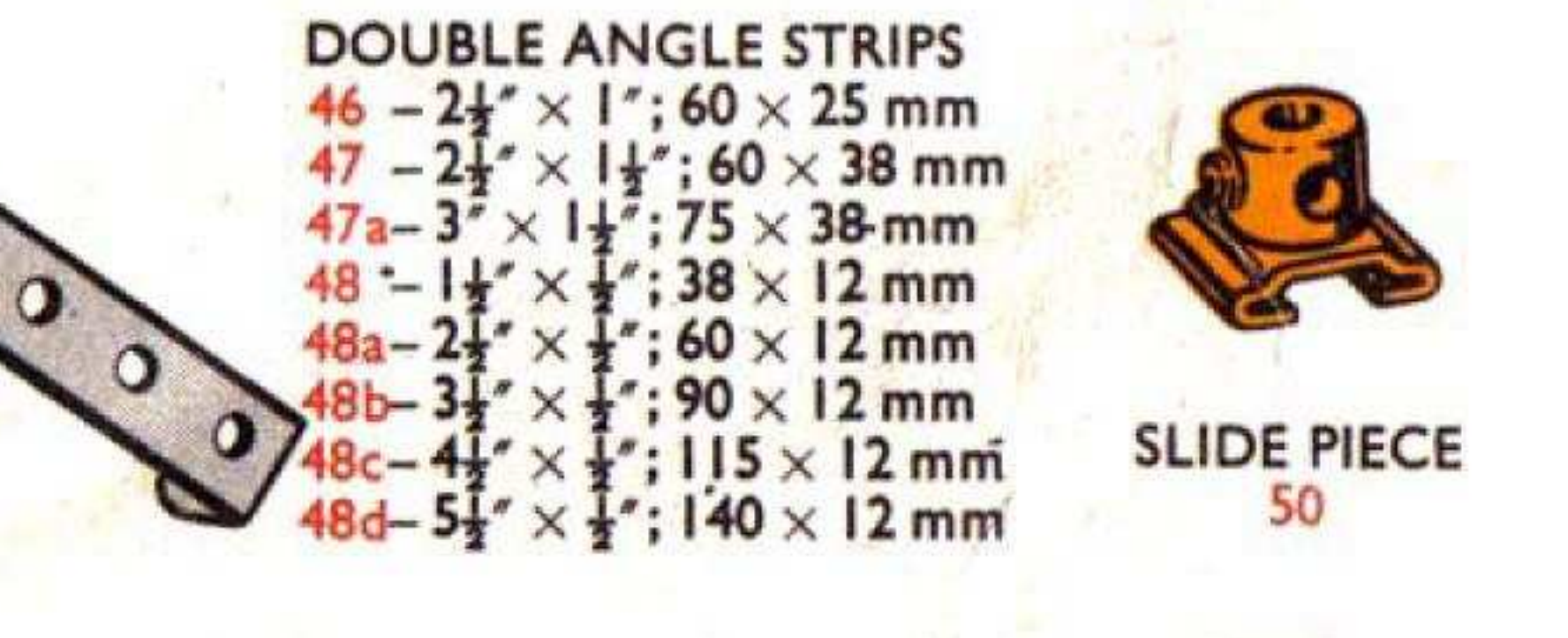
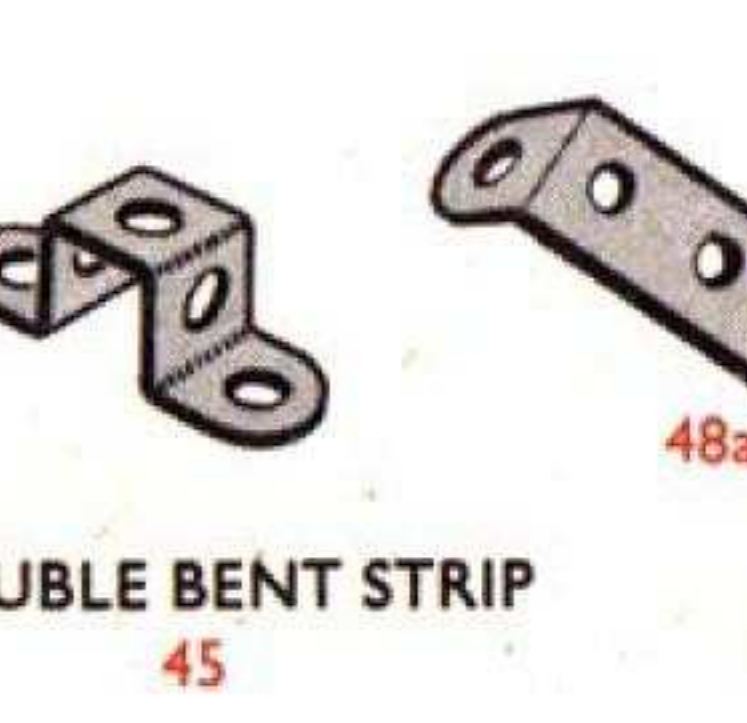
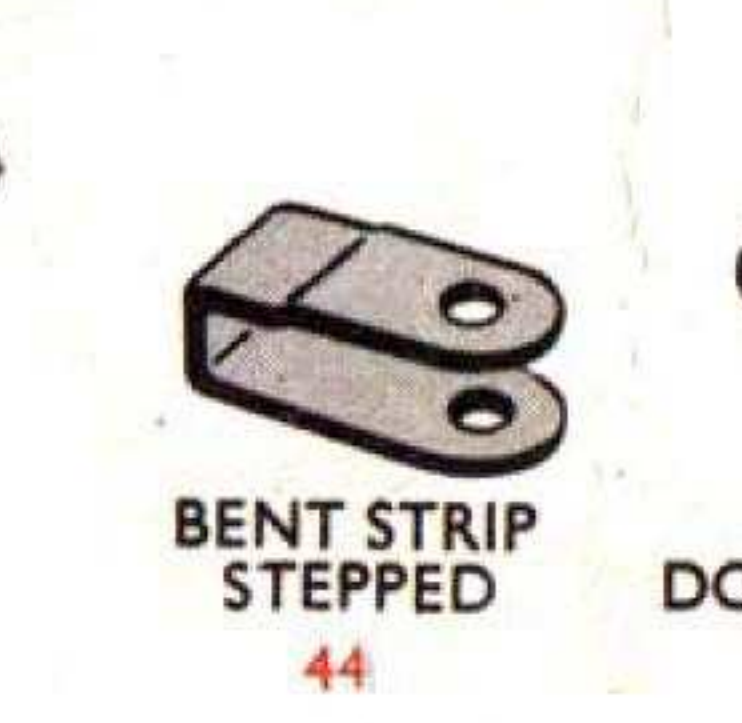
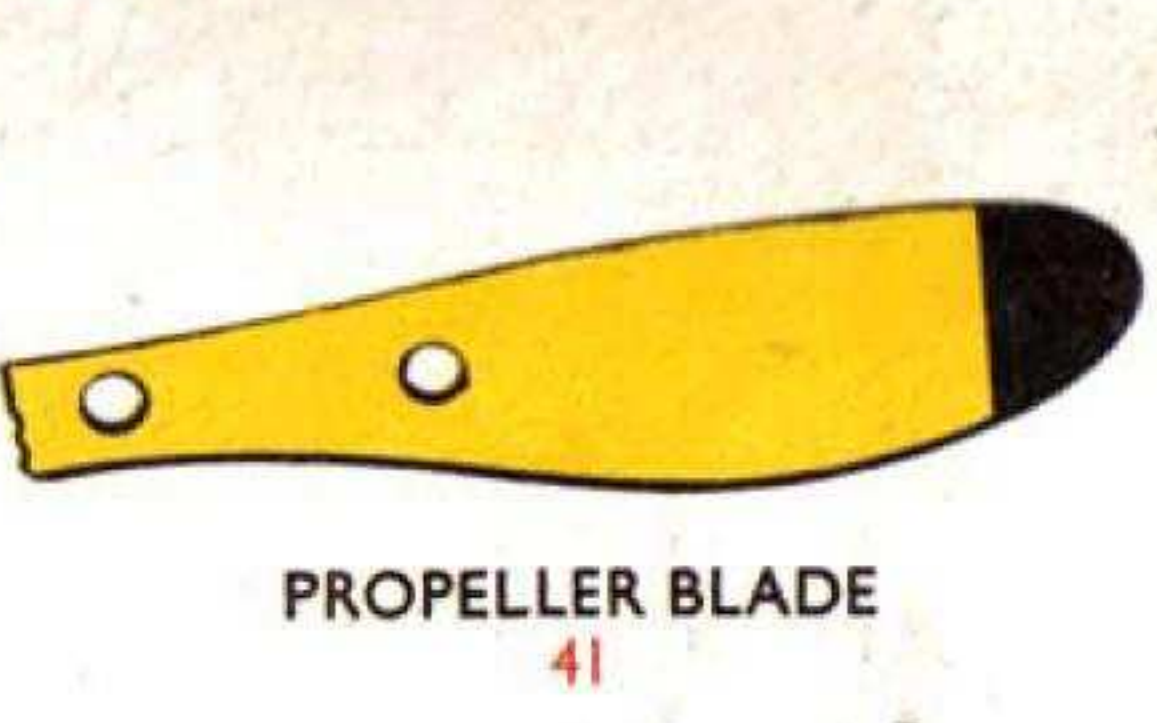
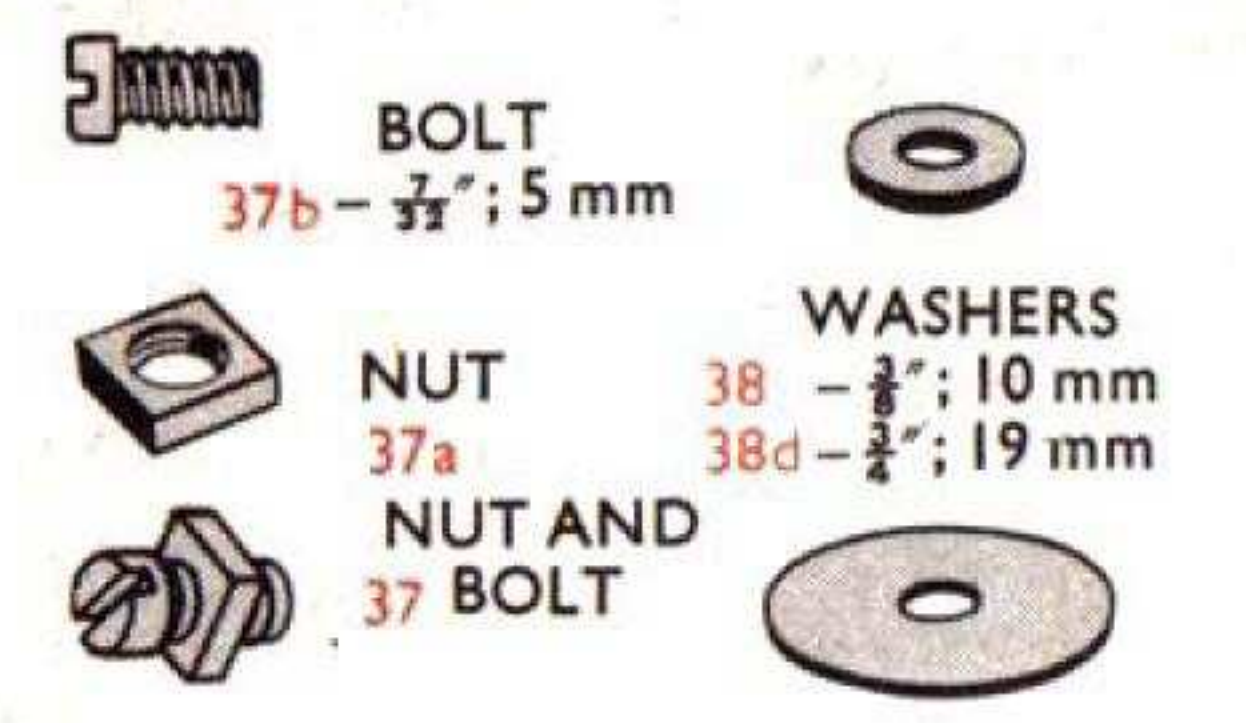
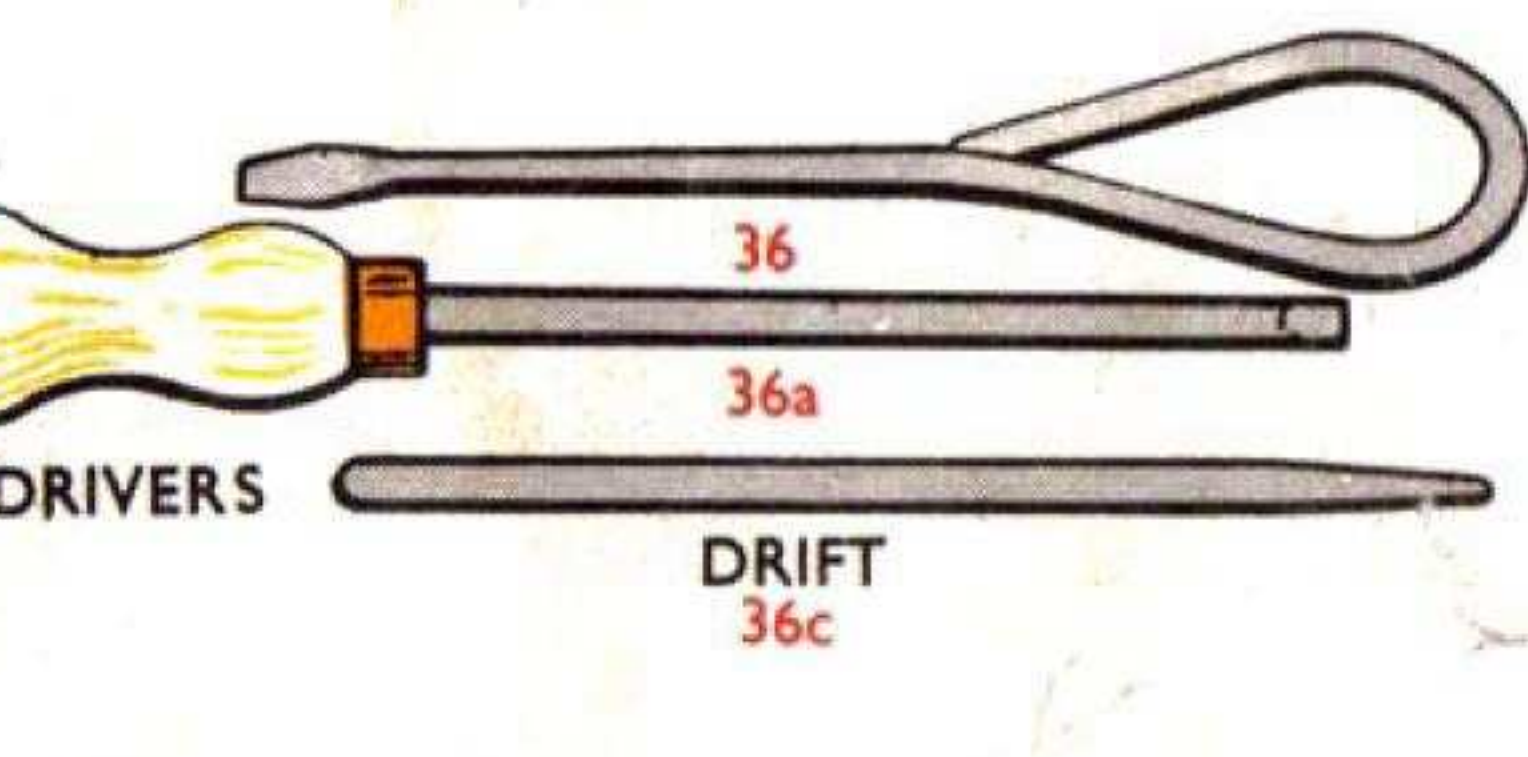
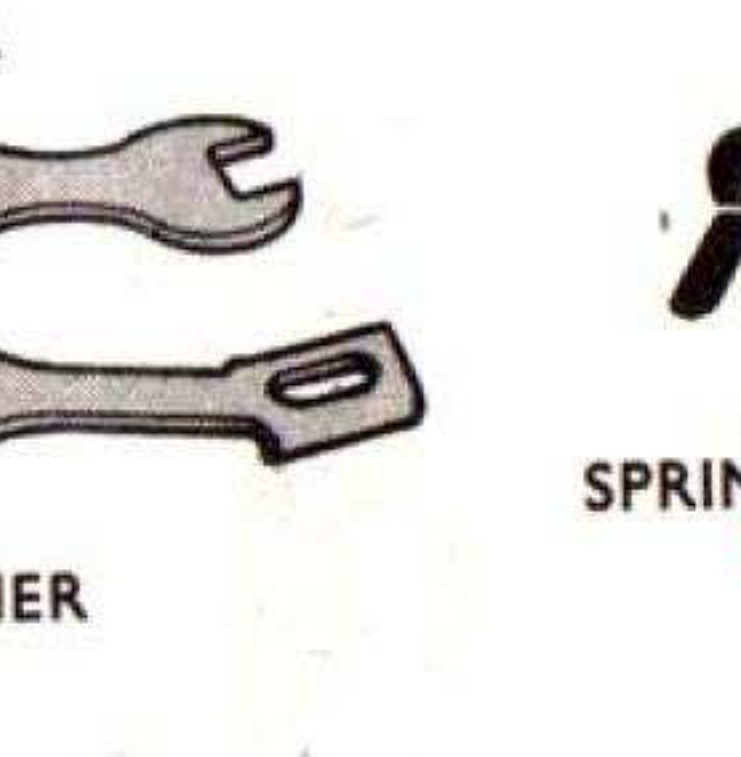
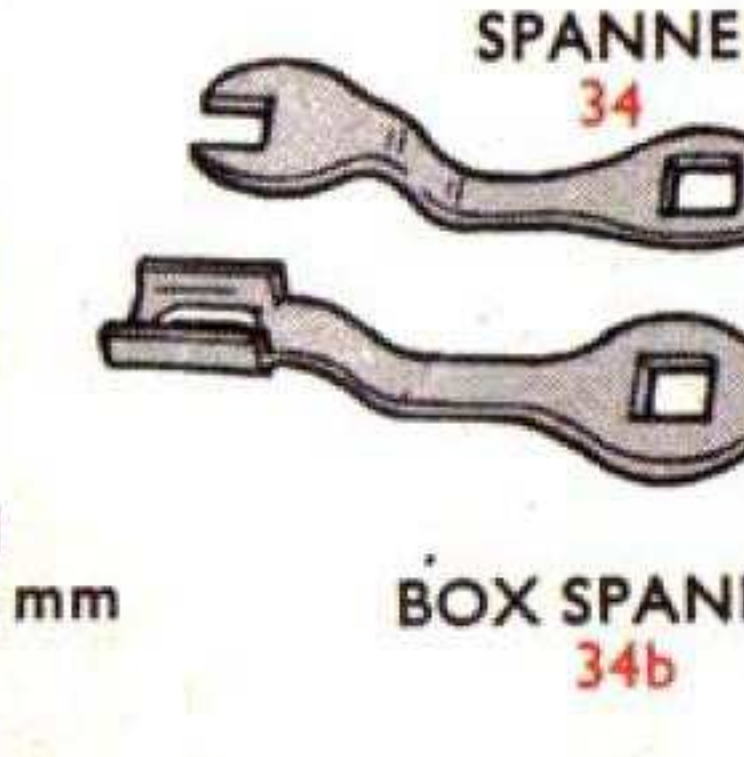
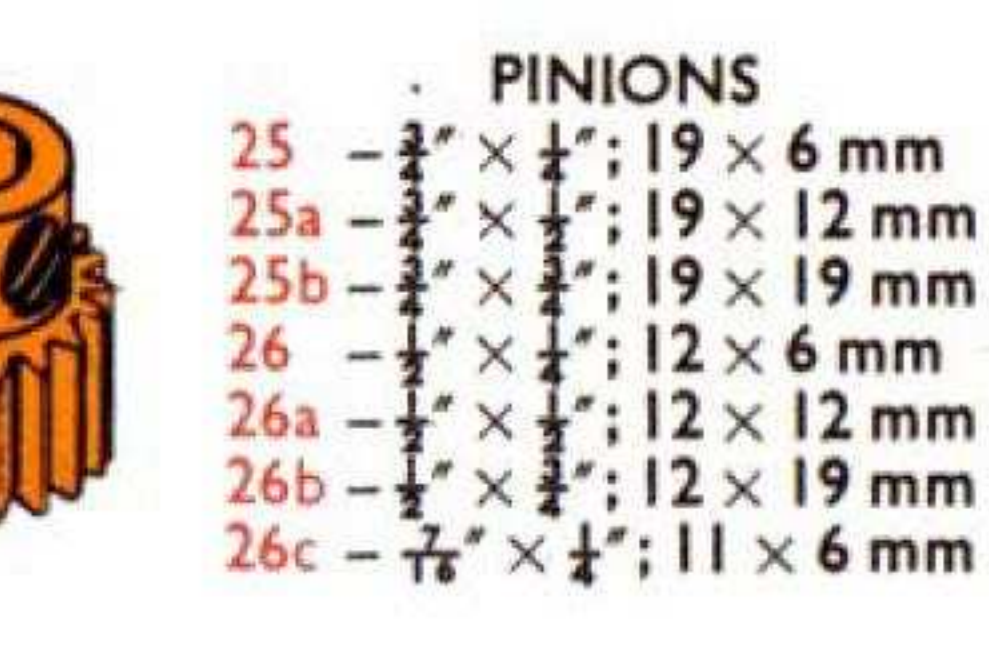
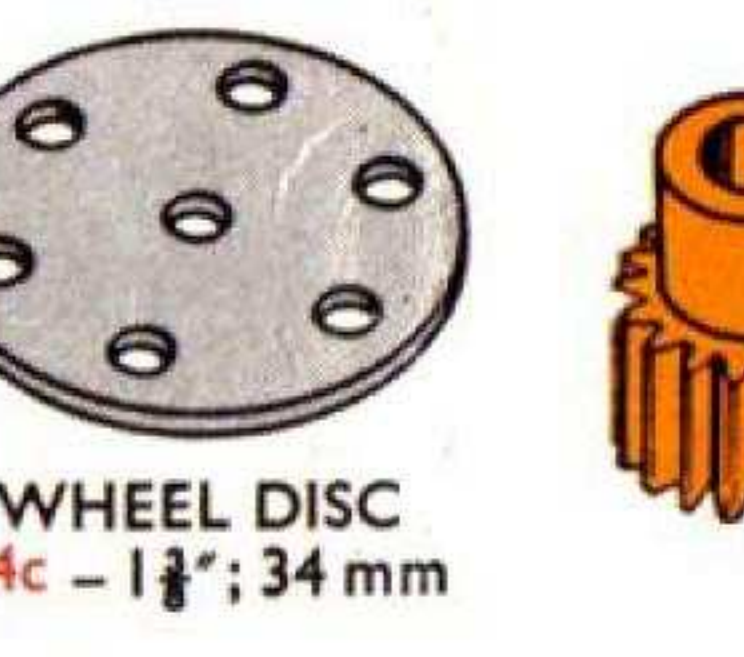
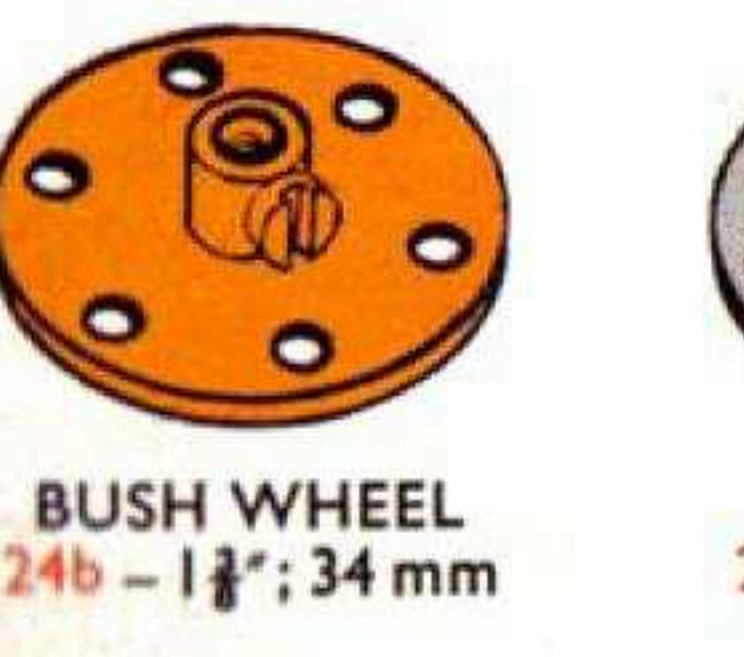
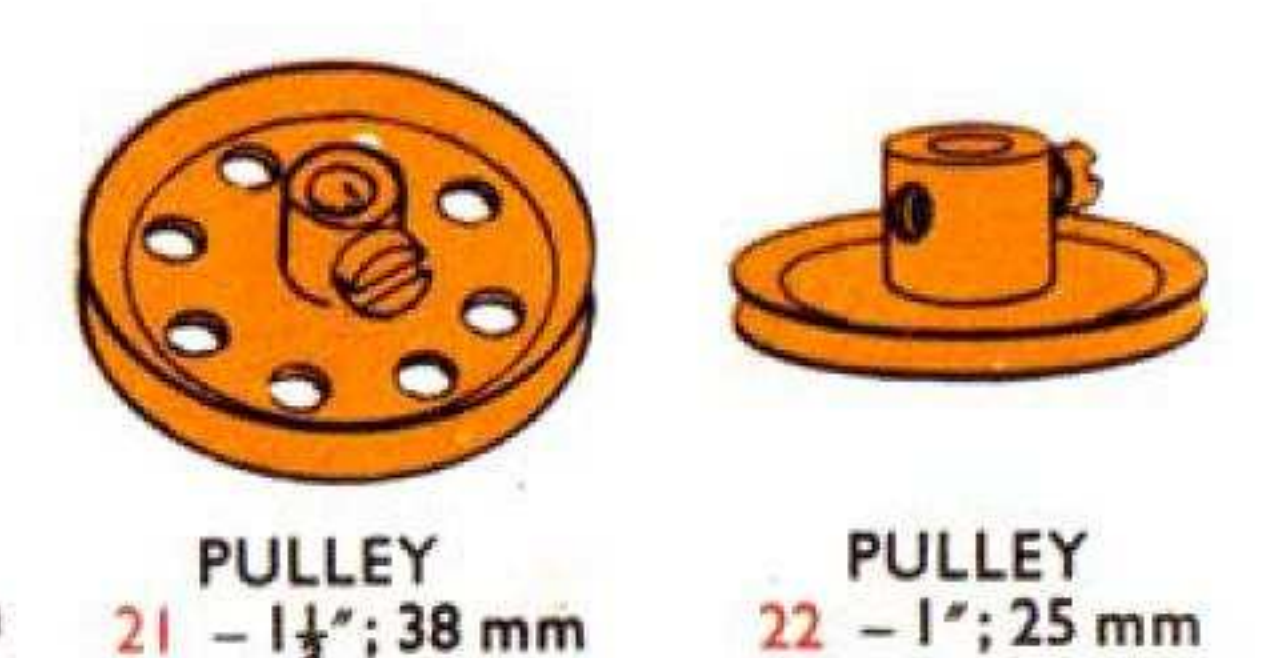
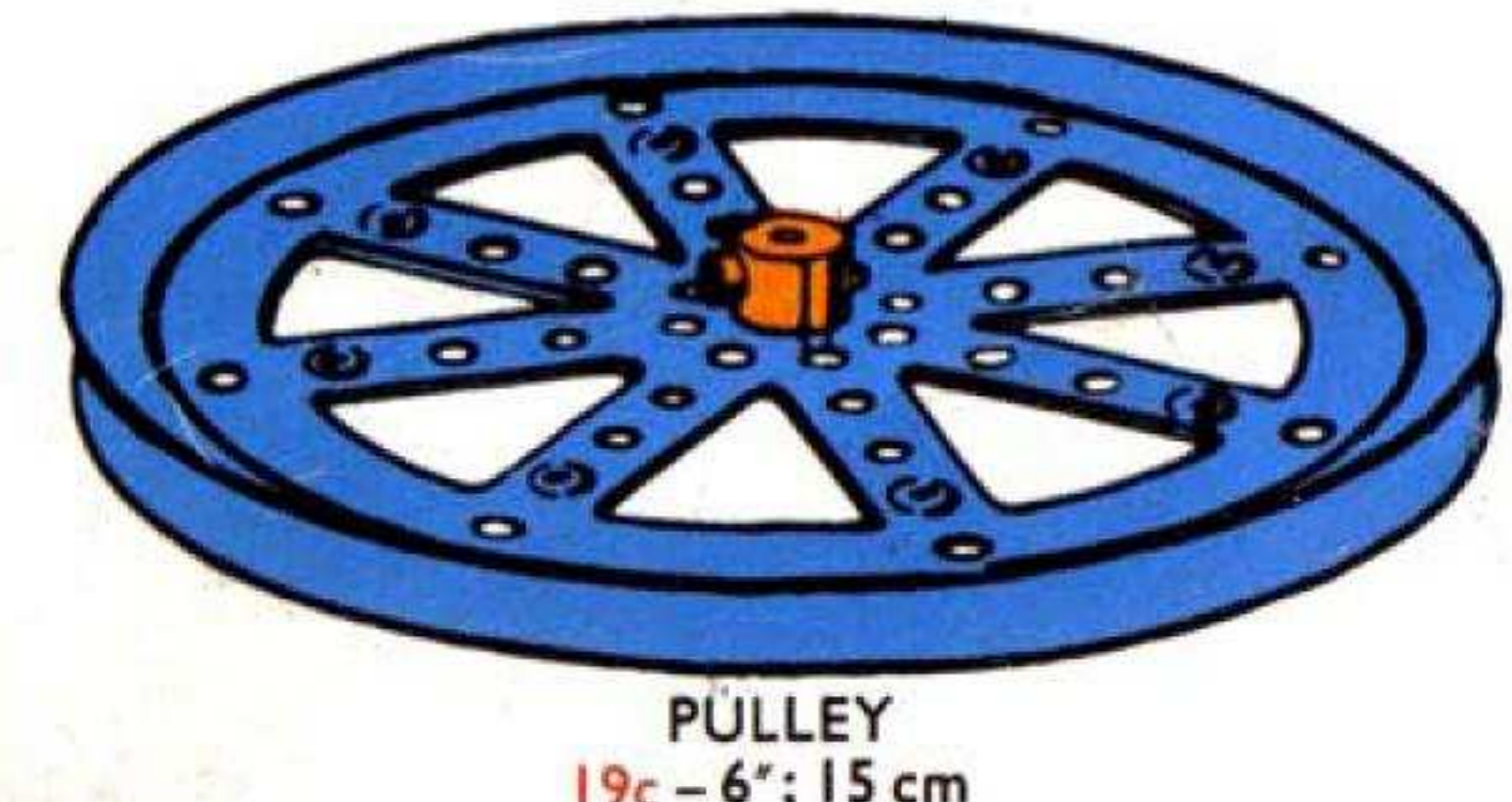
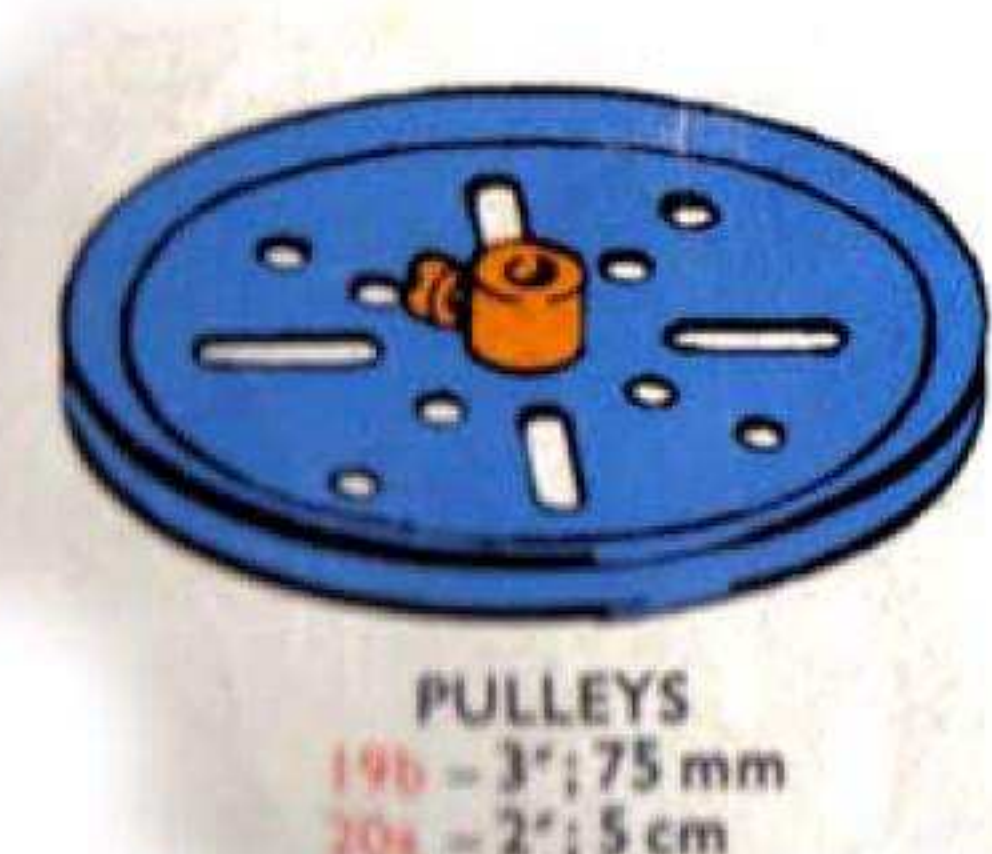
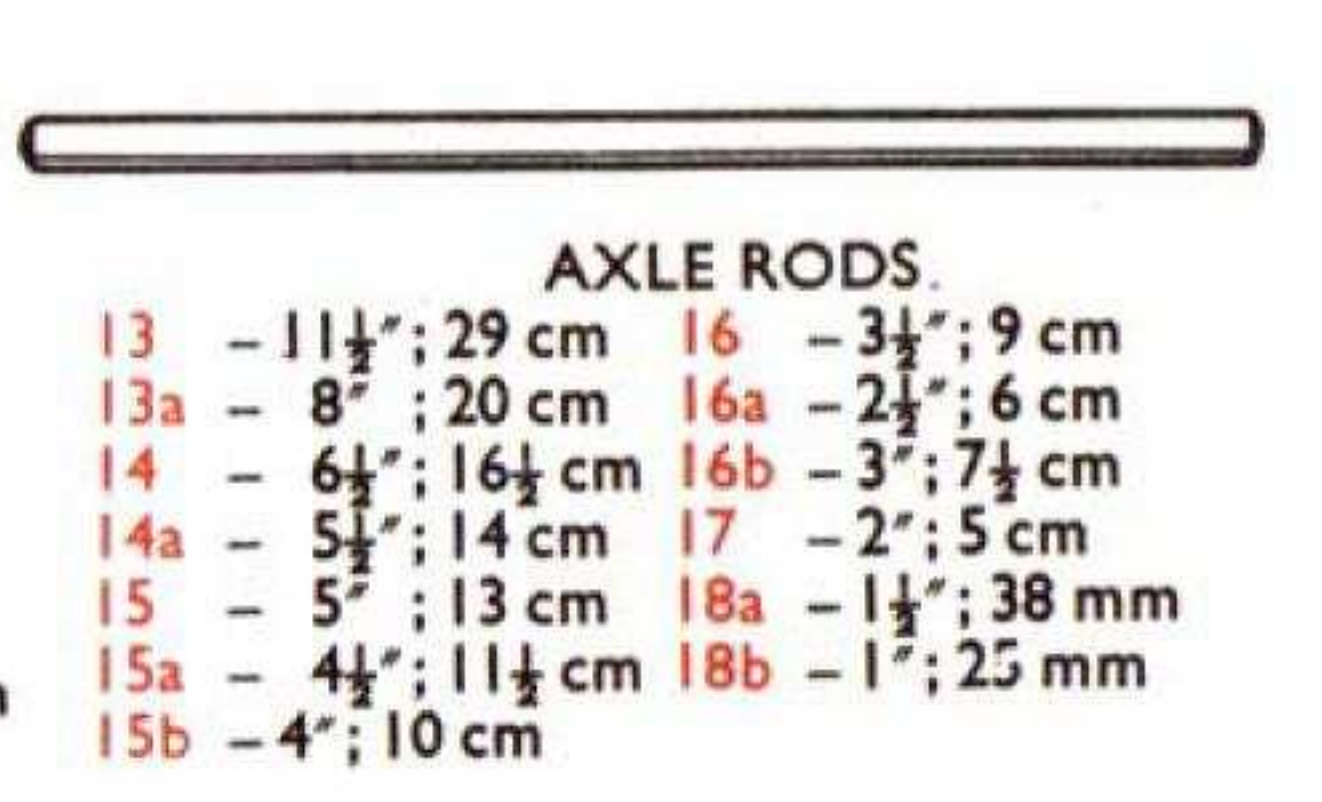
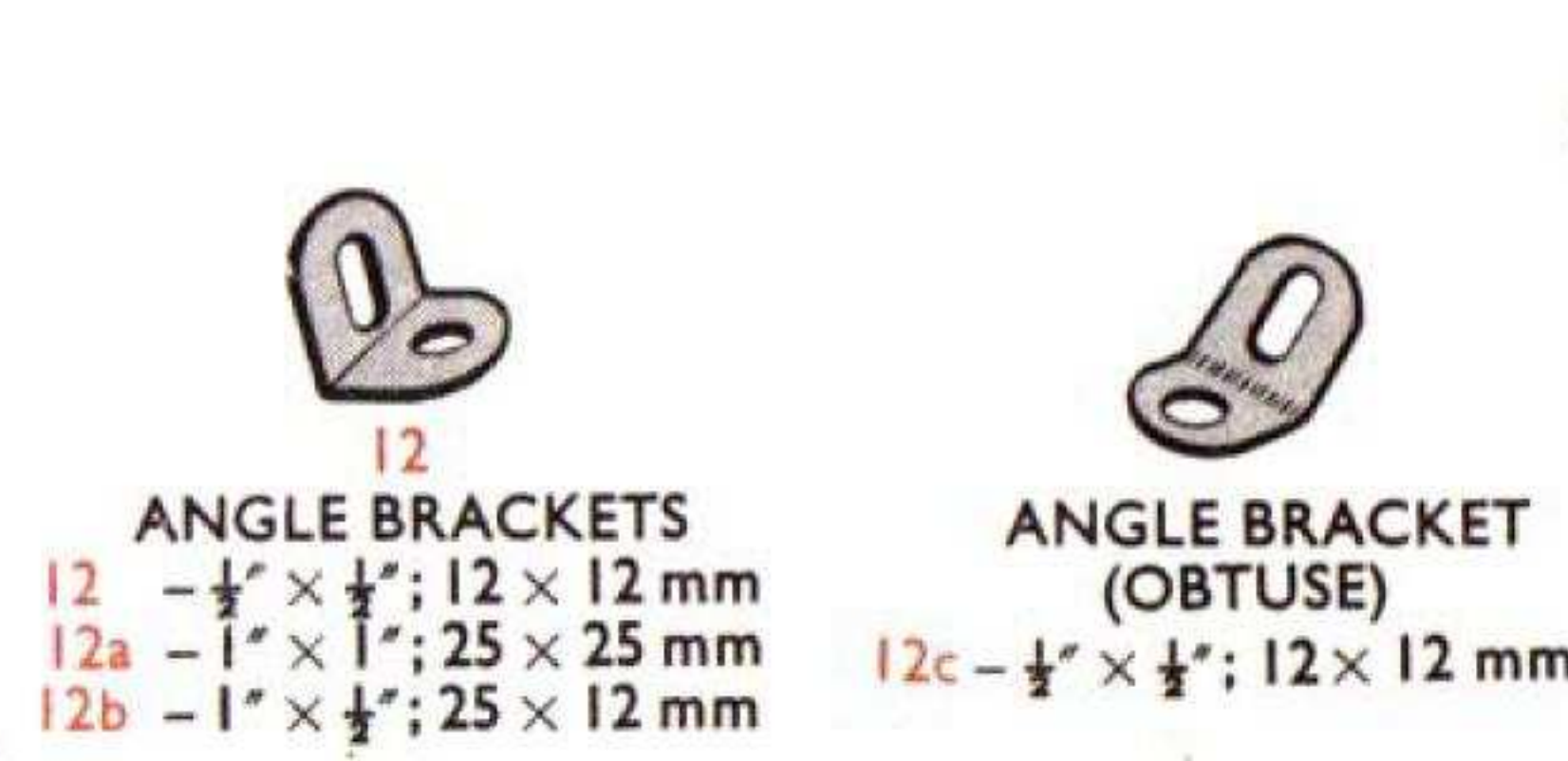
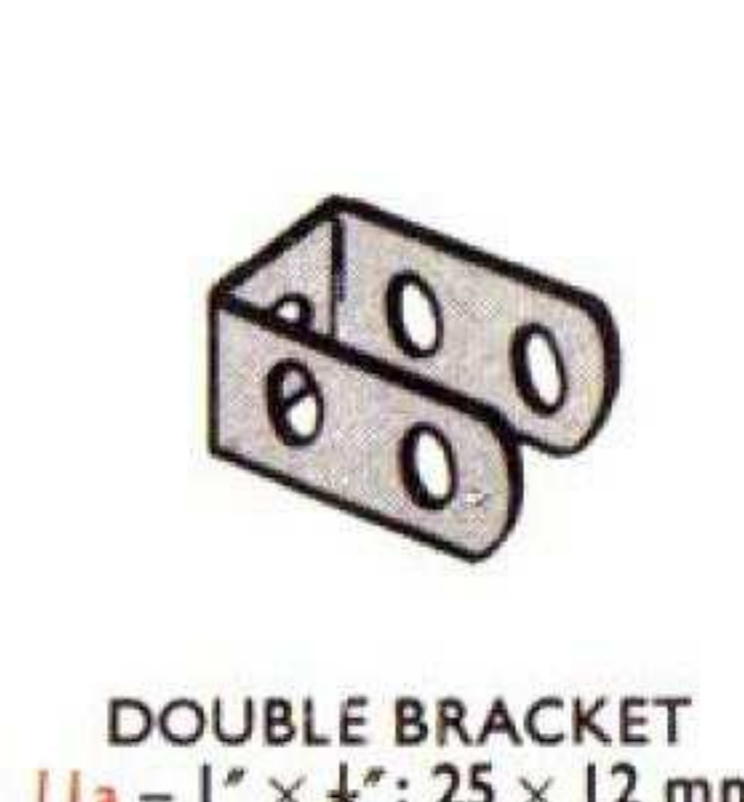
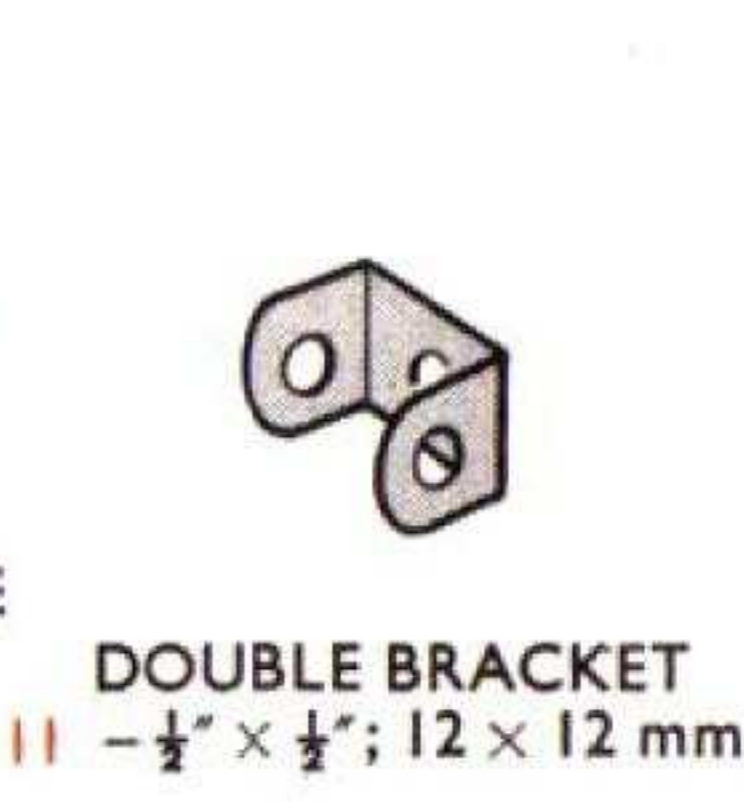
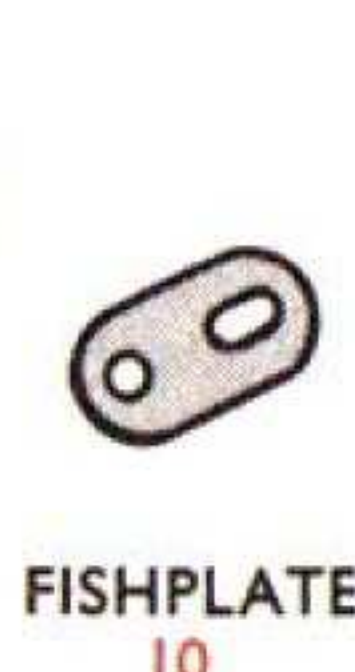
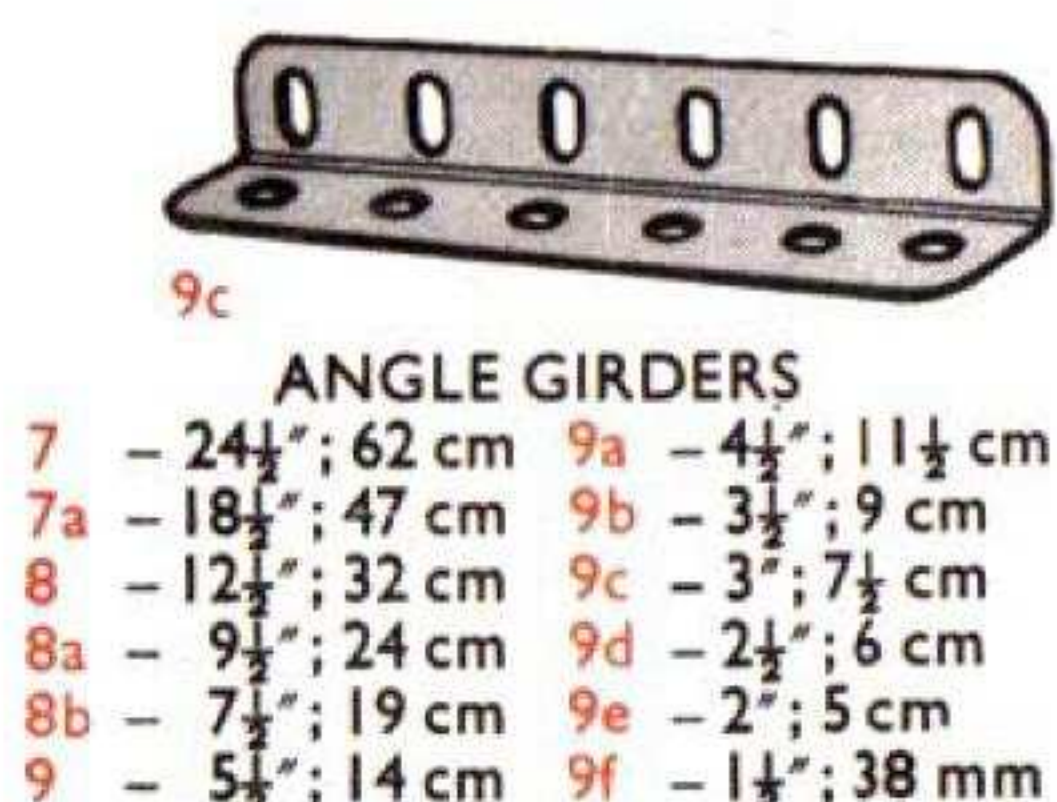
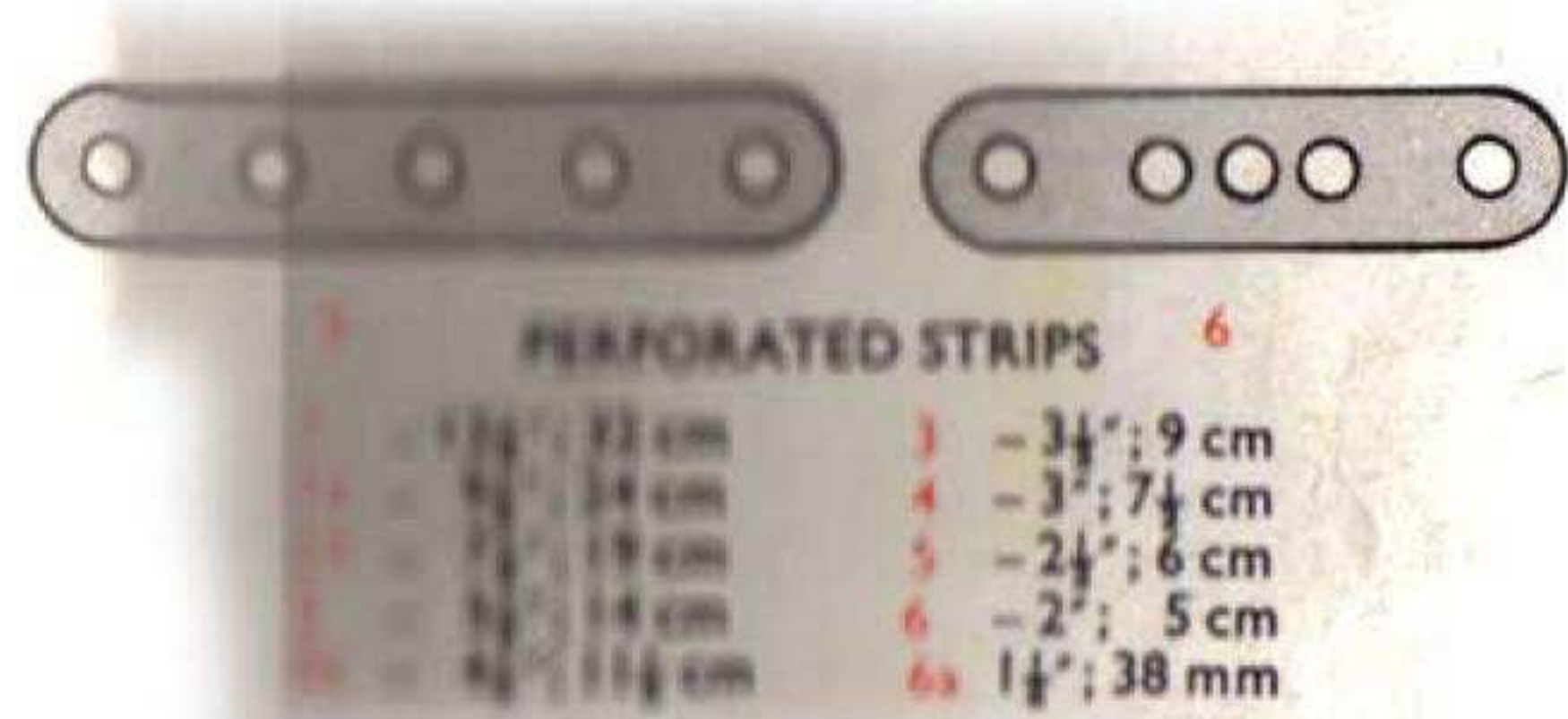

5.1

Car Ferry

Autovervoerboot

Ferry-boat pour voitures

Traghetto per automobili

Autofähre

Bilfärja

Buque transbordador de vehiculos

Ferry-boat

Bilferge

4- i	2- 35	2-126
8- 2	107- 37a	2-126a
2- 3	93- 37b	4-142c
8- 5	11- 38	2-155
3- 10	2- 38d	2-188
2- 11	1- 40	2-189
1- 11a	2- 48	4-190
10- 12	5- 48a	2-191
1- 12c	1- 51	2-192
4- 16	1- 52	1-193
1- 18a	2- 53a	2-194
1- 18b	2- 54	1-212
4- 22	2- 90a	2-212a
2- 22a	2-111	2-214
1- 23	4-111c	4-221
2- 24	2-125	

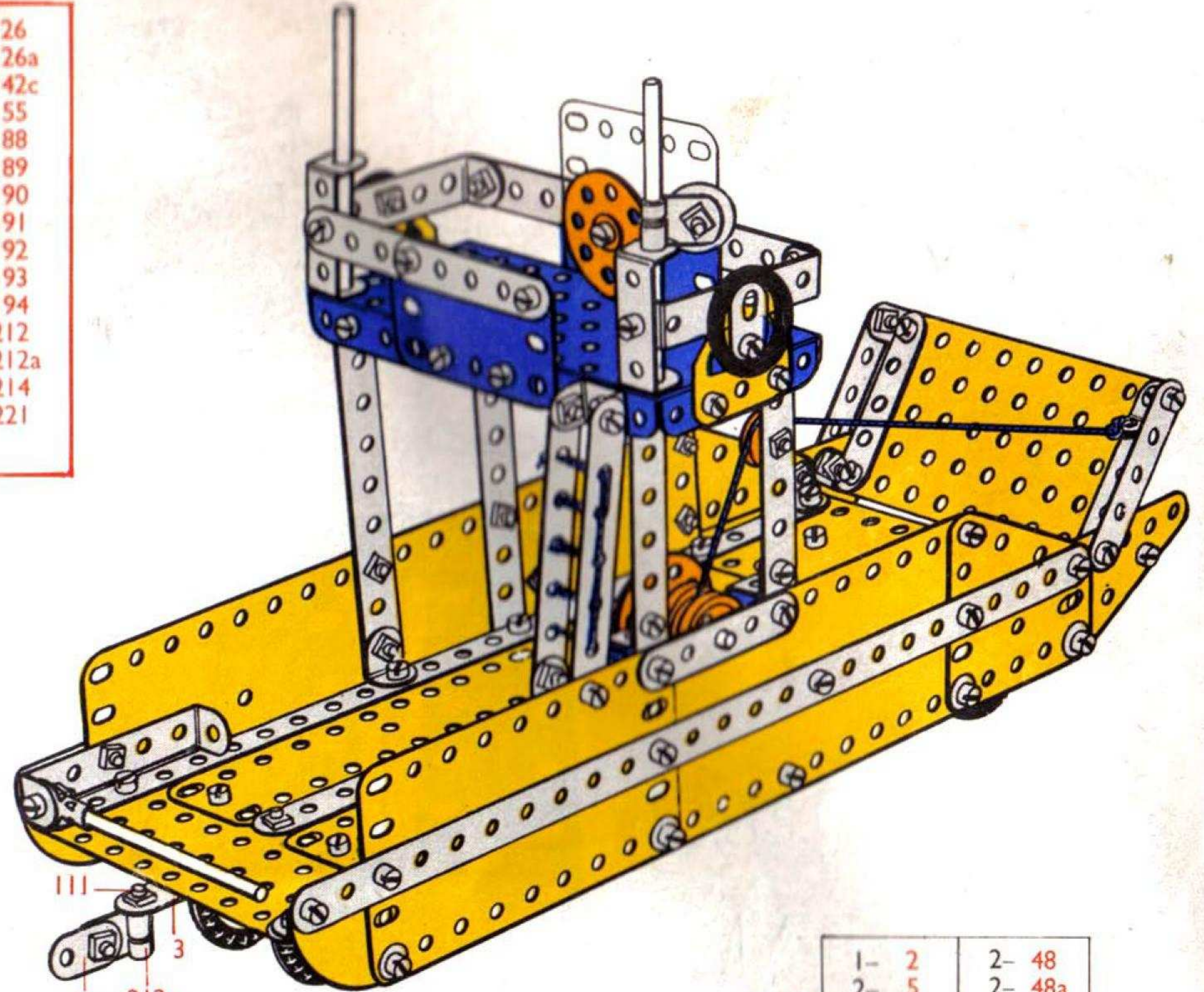

4- 1	1- 40
7- 2	3- 48a
2- 3	1- 51
6- 5	2- 53a
1- 10	2- 54
2- 11	2- 90a
1- 11a	1-111
10- 12	2-111c
1- 12c	2-125
2- 16	2-126
1- 18a	4-142c
1- 18b	2-188
4- 22	2-189
2- 22a	4-190
1- 23	2-191
1- 24	2-192
81- 37a	1-212
73- 37b	1-212a
10- 38	2-214
1- 38d	4-221

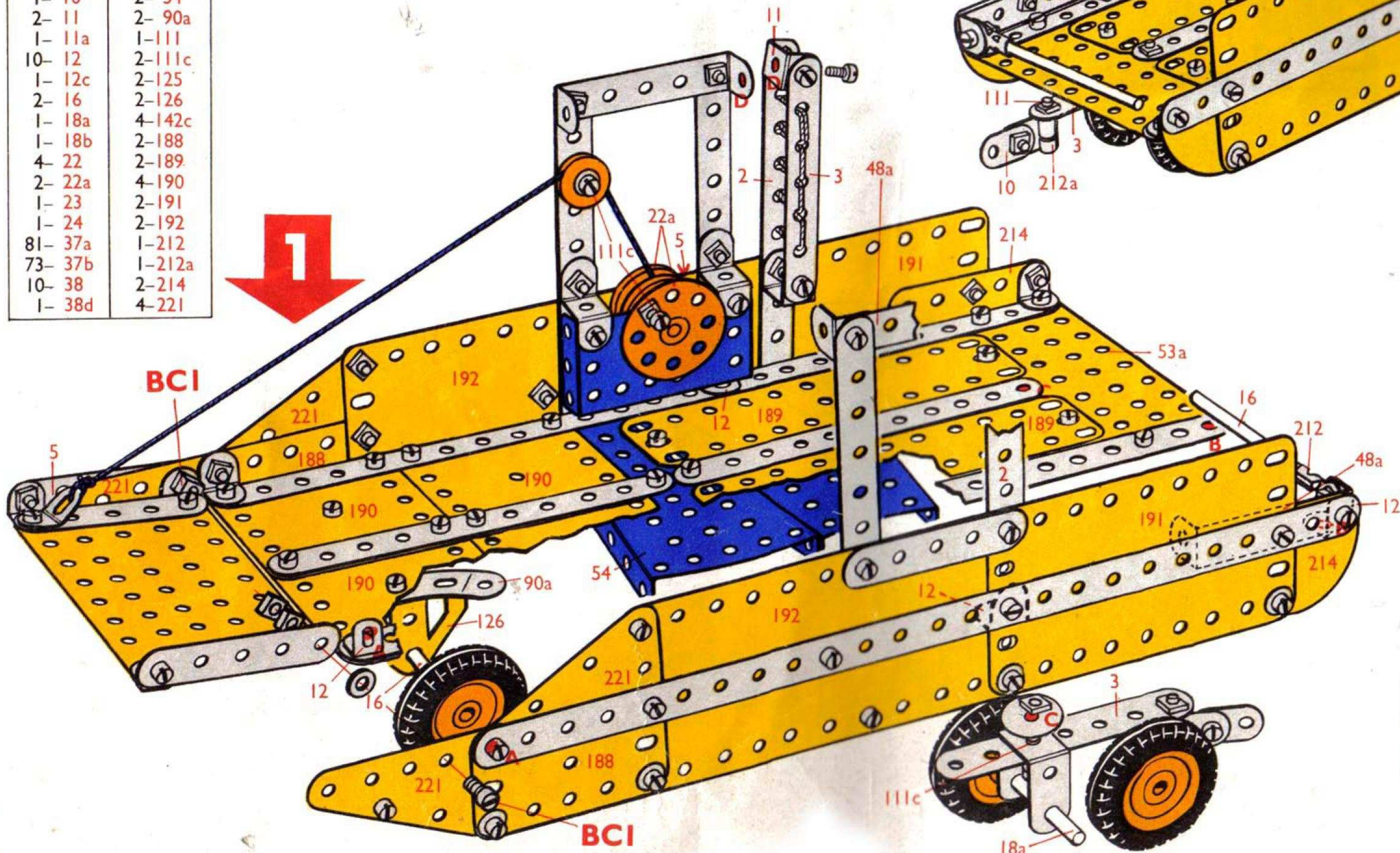

1- 2	2- 48
2- 5	2- 48a
2- 10	1- 52
2- 16	1-111
1- 24	2-111c
2- 35	2-126a
26- 37a	2-155
20- 37b	1-193
1- 38	2-194
1- 38d	1-212a

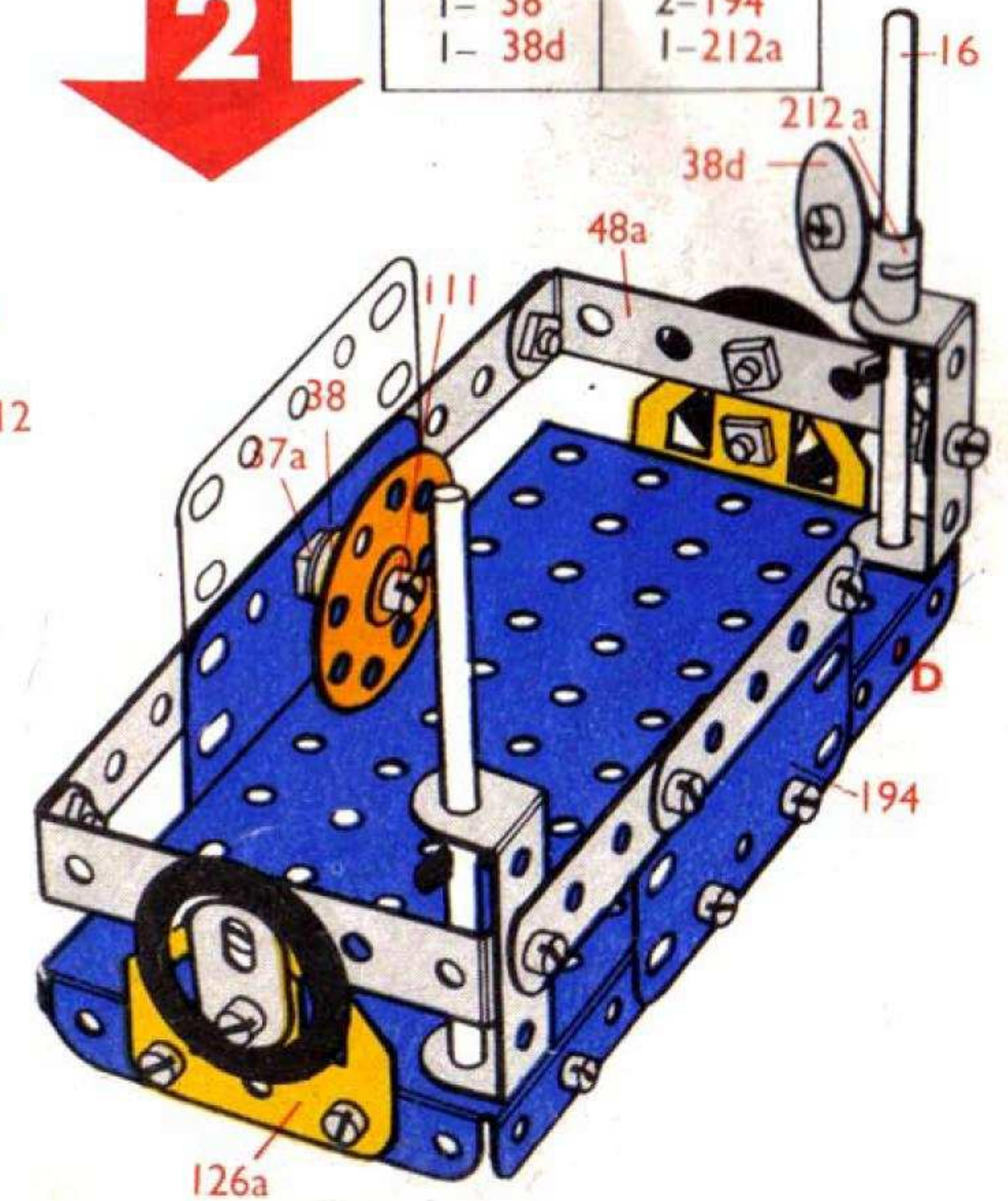

5.2

Swing Bridge
Draaibrug
Pont basculant
Ponte girevole
Drehbrücke
Svängbro
Puente giratorio
Ponte levadiça
Svingbro

4- 1	2- 24	4- IIIc
8- 2	2- 27f	2- 125
2- 3	4- 35	2- 126
9- 5	101- 37a	2- 126a
4- 10	93- 37b	2- 188
1- 11	13- 38	2- 189
9- 12	1- 40	4- 190
2- 12c	6- 48a	2- 191
1- 15b	1- 51	2- 192
3- 16	1- 52	2- 194
1- 19s	2- 53a	2- 212a
1- 20a	2- 54	2- 214
3- 22	4- 90a	4- 221
1- 23a	2- IIIa	

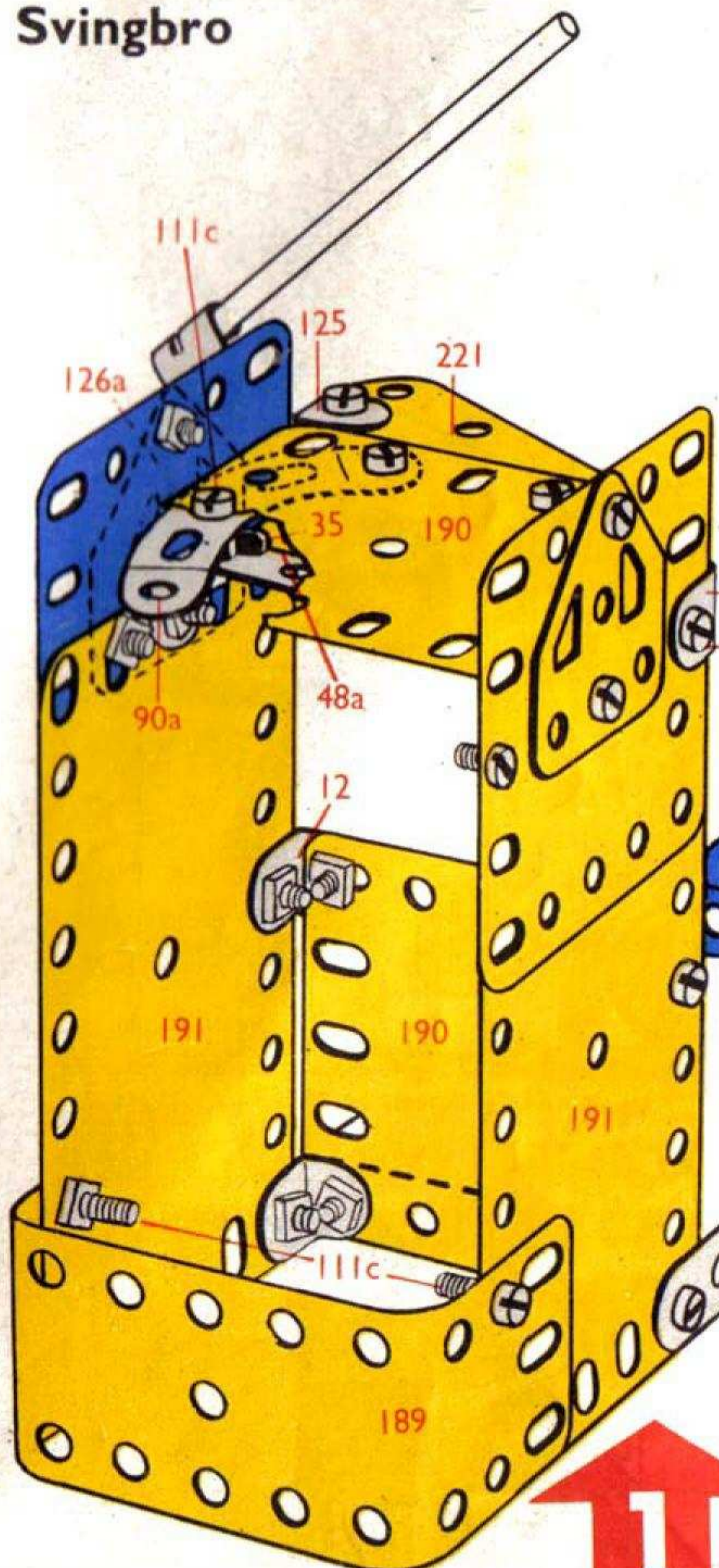
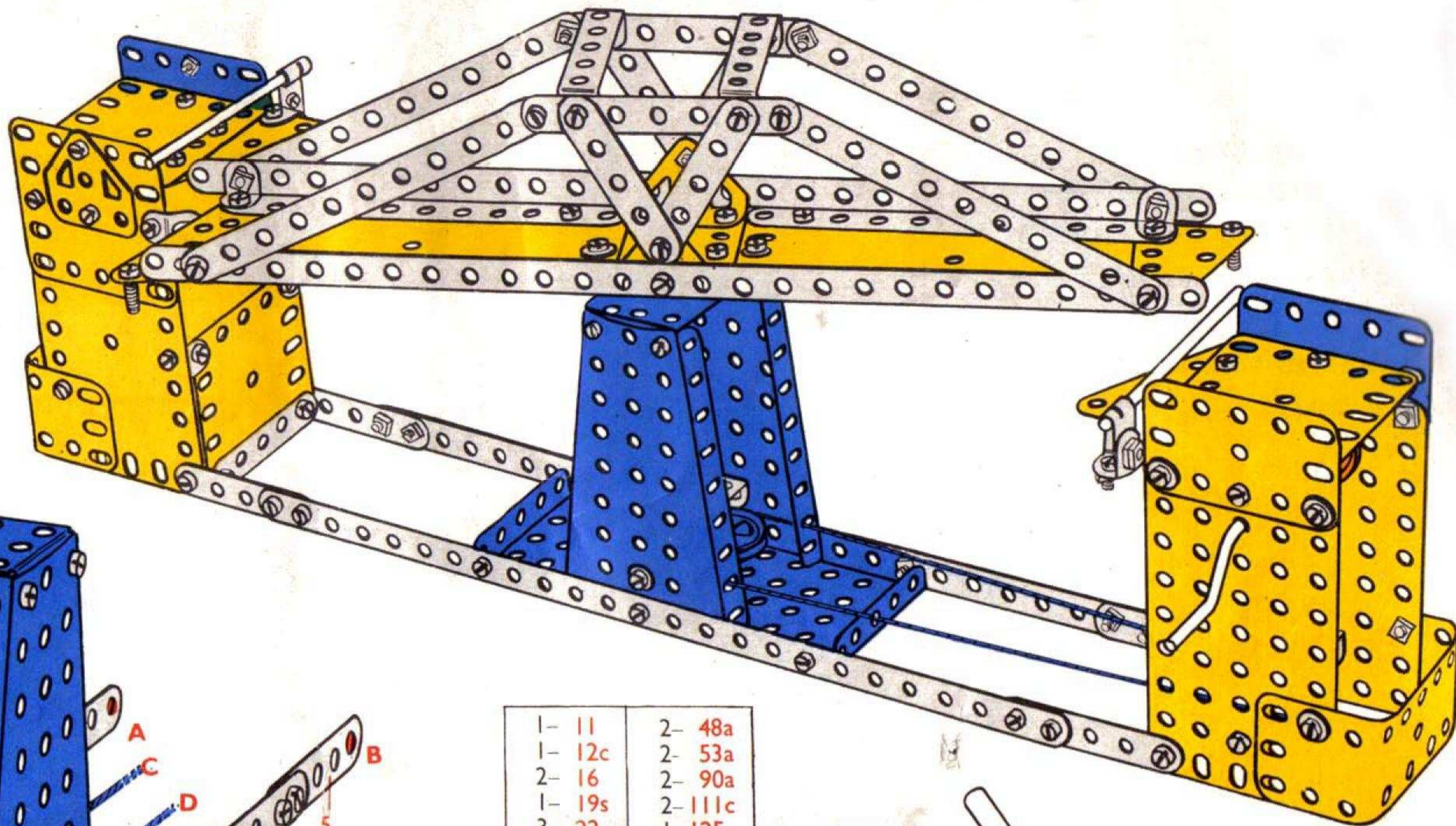

2- 1	44- 37b	1- 125
5- 5	2- 38	2- 126a
5- 12	1- 40	1- 189
1- 12c	2- 48a	3- 190
1- 15b	1- 51	2- 191
1- 16	1- 52	1- 194
1- 20a	2- 54	1- 212a
2- 35	2- 90a	1- 221
47- 37a	4- IIIc	

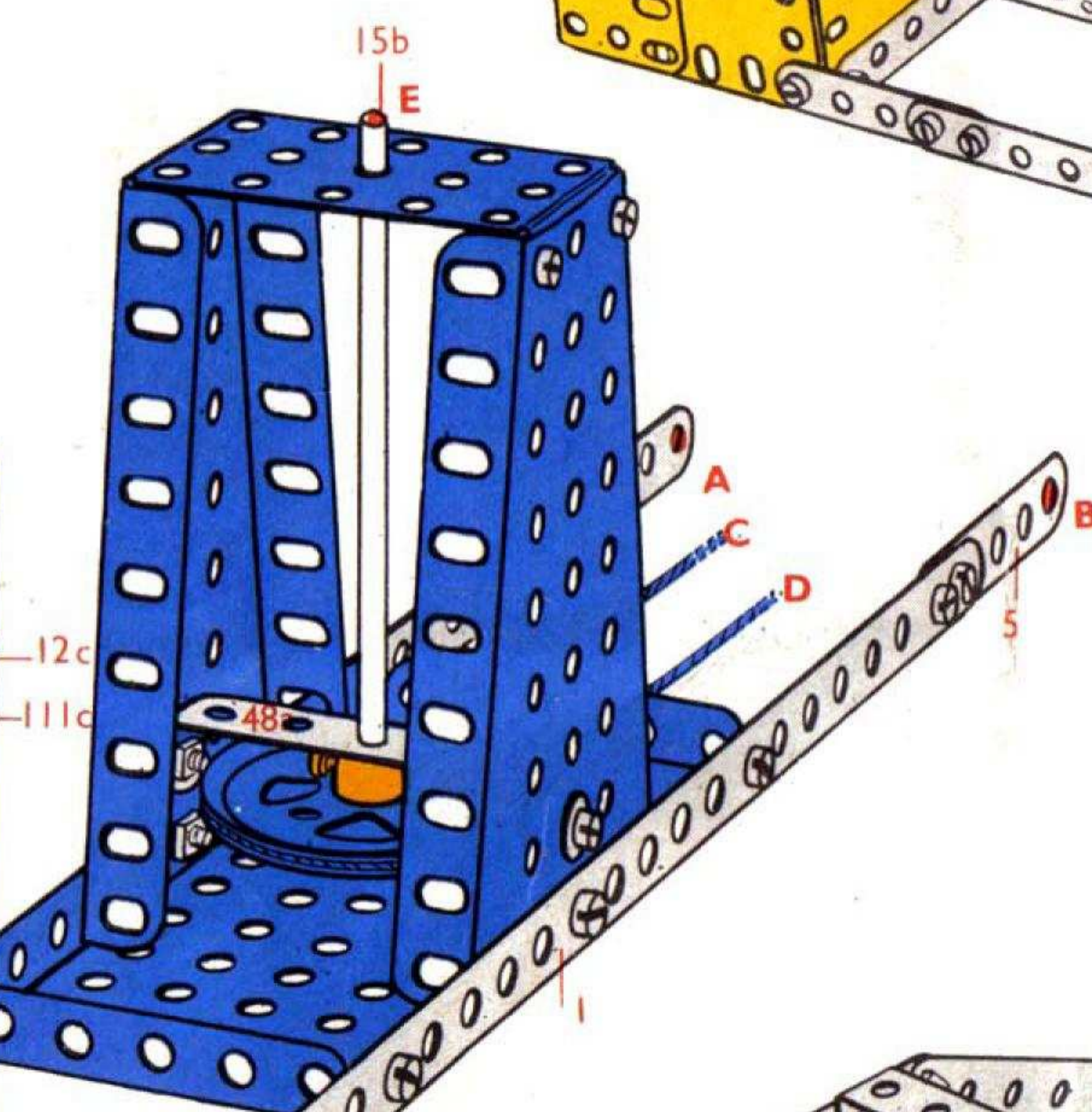

1- 11	2- 48a
1- 12c	2- 53a
2- 16	2- 90a
1- 19s	2- IIIc
3- 22	1- 125
1- 23a	1- 188
1- 24	1- 189
2- 27f	1- 190
2- 35	1- 194
20- 37a	1- 212a
17- 37b	1- 221
9- 38	

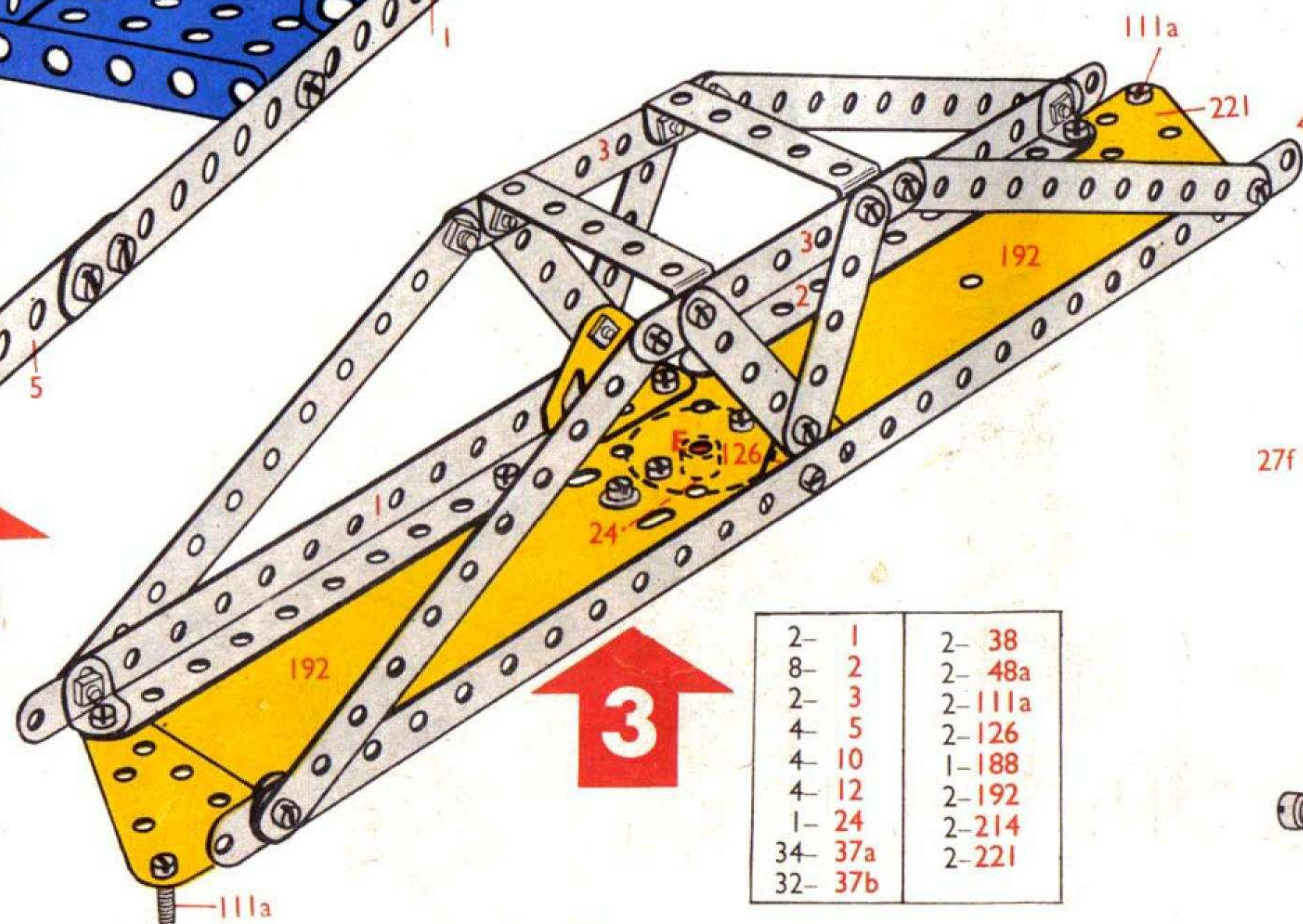

2- 1	2- 38
8- 2	2- 48a
2- 3	2- IIIa
4- 5	2- 126
4- 10	1- 188
4- 12	2- 192
1- 24	2- 214
34- 37a	2- 221
32- 37b	

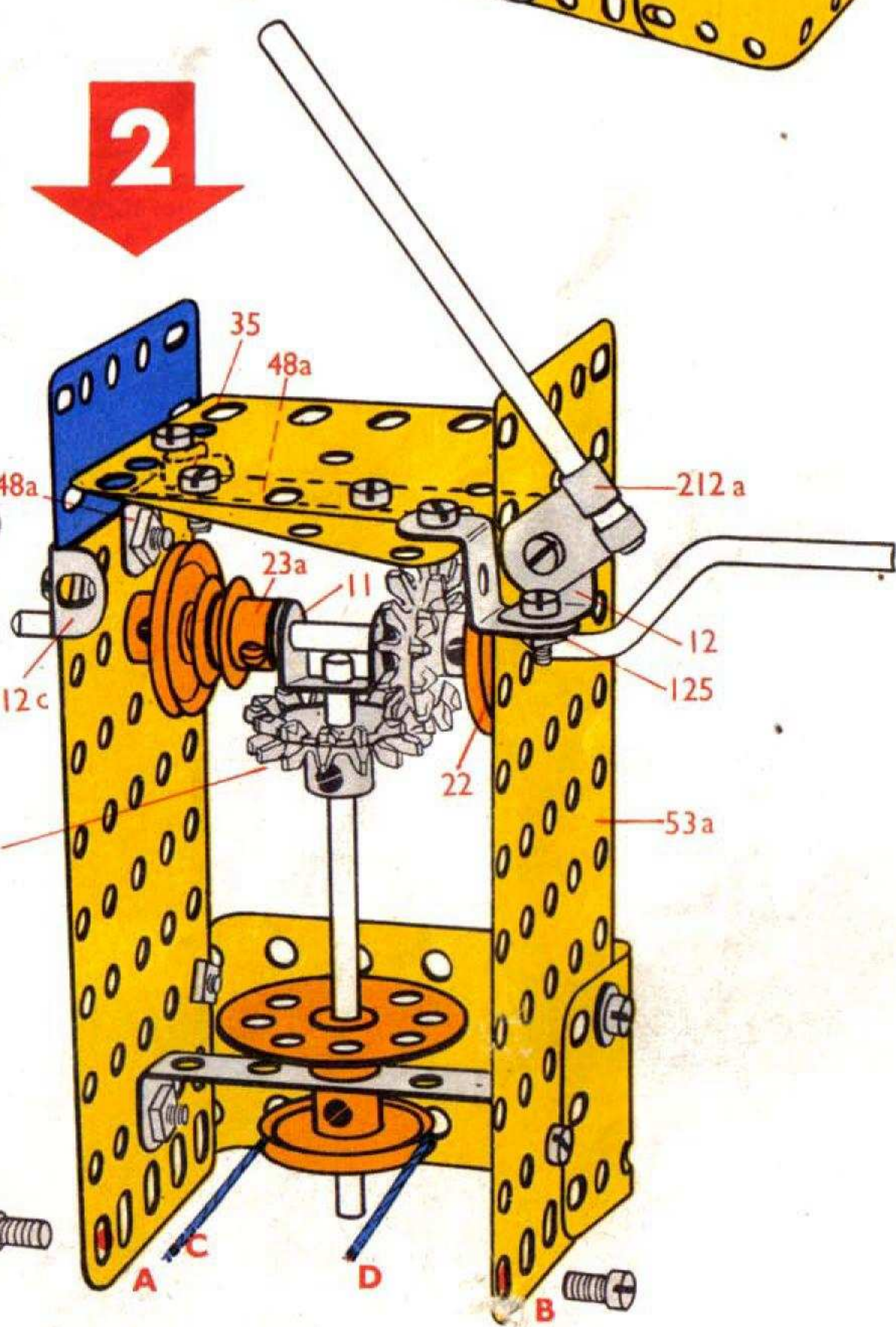

5.3

Heavy Goods Lorry

Zware vrachtwagen

Camion poids-lourd

Autocarro per servizio pesante

Schwerlastwagen

Tung lastbil

Camión de mercancías pesadas

Camião de carga

Tung lastebil

4- 1	2- 22	1- 52	2-189
8- 2	2- 22a	2- 53a	4-190
2- 3	1- 23	3- 90a	2-191
9- 5	1- 23a	1-111	2-192
4- 10	1- 24	1-111a	2-193
2- 11	8- 35	6-111c	1-193a
1- 11a	107- 37a	2-125	2-194a
6- 12	93- 37b	2-126	2-212a
1- 12c	14- 38	2-126a	1-213
2- 16	2- 38d	1-155	2-214
2- 17	2- 48	*1-186b	4-215
2- 18a	6- 48a	4-187	4-221
1- 18b	1- 51	2-188	*1-M2

* Not included in set

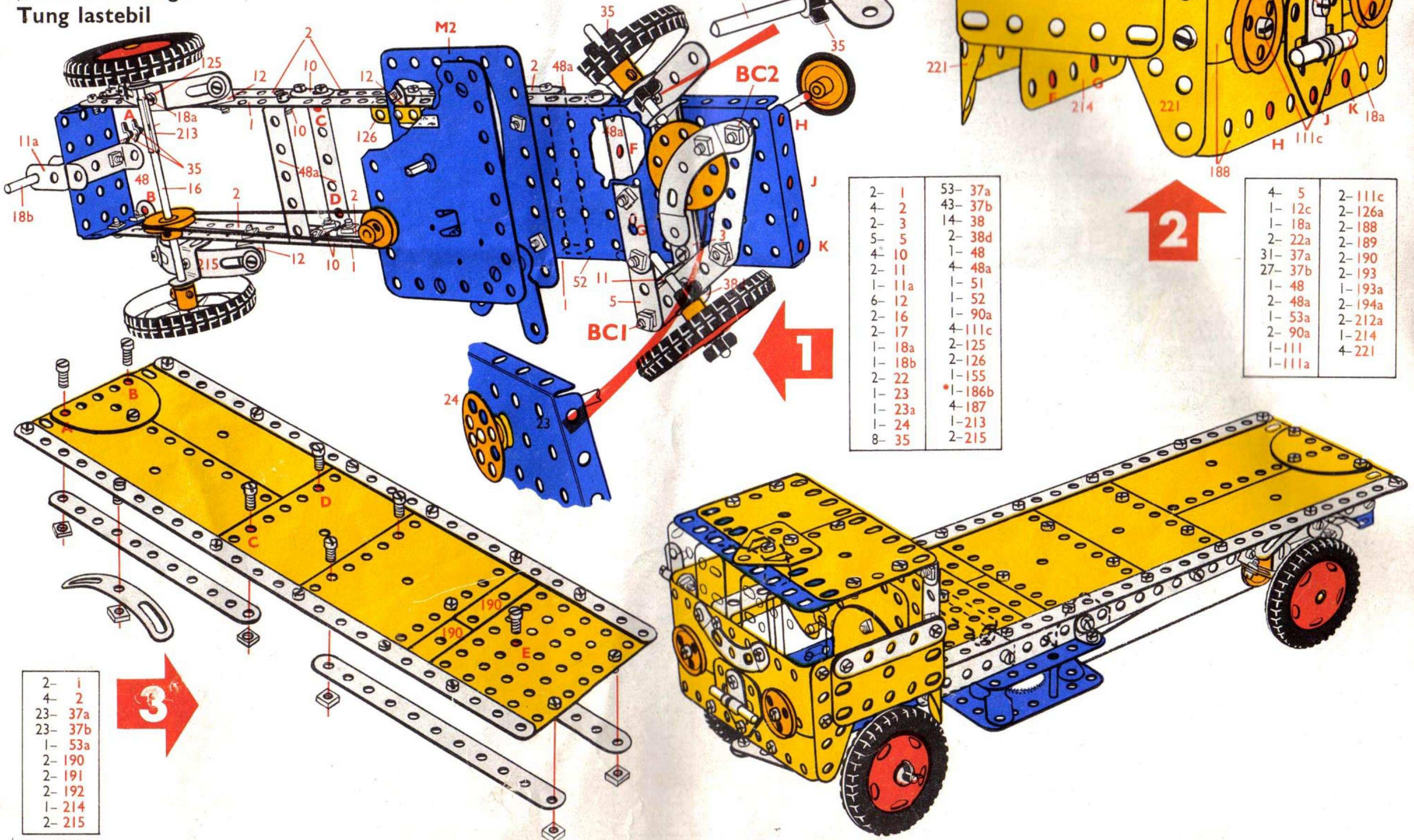

2- 1	53- 37a
4- 2	43- 37b
2- 3	14- 38
5- 5	2- 38d
4- 10	1- 48
2- 11	4- 48a
1- 11a	1- 51
6- 12	1- 52
2- 16	1- 90a
2- 17	4-111c
1- 18a	2-125
1- 18b	2-126
2- 22	1-155
1- 23	*1-186b
1- 23a	4-187
1- 24	1-213
8- 35	2-215

4- 5	2-111c
1- 12c	2-126a
1- 18a	2-188
2- 22a	2-189
31- 37a	2-190
27- 37b	2-193
1- 48	1-193a
2- 48a	2-194a
1- 53a	2-212a
2- 90a	1-214
1-111	4-221
1-111a	

2- i
4- 2
23- 37a
23- 37b
1- 53a
2- 190
2- 191
2- 192
1- 214
2- 215

5.4

Moon Explorer
Maanvoertuig
Engin d'exploration lunaire
Esploratore lunare
Mondfahrzeug
Månfarkost
Explorador lunar
Måneutforsker

4- 1	1- 18a	2- 48	1-176
8- 2	1- 18b	6- 48a	1-186
2- 3	1- 19s	1- 51	3-187
7- 5	1- 20a	1- 52	2-188
4- 10	4- 22	2- 53a	2-192
2- 11	1- 22a	2- 54	1-212
1- 11a	2- 24	2- 90a	1-212a
10- 12	9- 35	1-111a	1-213
4- 12c	105- 37a	6-111c	1-215
1- 15b	83- 37b	1-126	2-221
2- 16	8- 38	3-142c	
2- 17	1- 40	1-155	

1- 2	4- 38
7- 5	1- 40
1- 11a	1- 48
2- 12	2- 90a
1- 16	1-111a
1- 19s	6-111c
1- 20a	1-176
1- 22	1-186
5- 35	2-188
40- 37a	2-221
18- 37b	

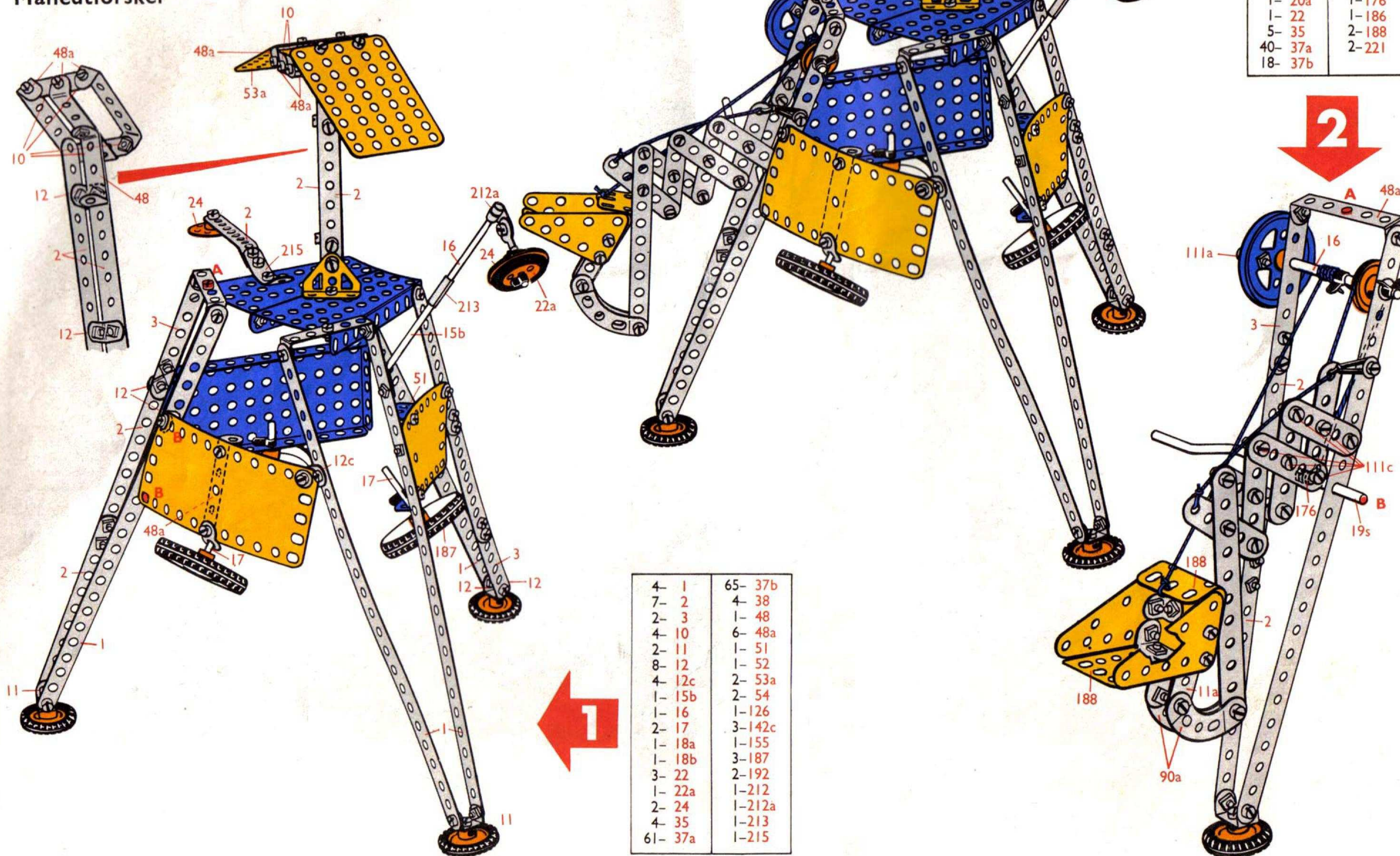

4- 1	65- 37b
7- 2	4- 38
2- 3	1- 48
4- 10	6- 48a
2- 11	1- 51
8- 12	1- 52
4- 12c	2- 53a
1- 15b	2- 54
1- 16	1-126
2- 17	3-142c
1- 18a	1-155
1- 18b	3-187
3- 22	2-192
1- 22a	1-212
2- 24	1-212a
4- 35	1-213
61- 37a	1-215

5.5

Car Ramp
Auto-oprit
Rampe pour voitures
Rampa per auto
Autorampe
Bilbrygga
Rampa para automóviles
Rampa para automóveis
Bilrampe

4- 1	1- 18b	1- 40	4- 142c
8- 2	1- 19s	1- 48	1- 186
2- 3	1- 20a	6- 48a	2- 188
9- 5	4- 22	1- 52	2- 189
4- 10	2- 22a	2- 53a	2- 191
2- 11	2- 24	2- 54	2- 192
4- 12	7- 35	3- 90a	1- 193
2- 12c	74- 37a	5- 111c	2- 212a
1- 15b	66- 37b	2- 125	2- 221
2- 16	14- 38	2- 126	
1- 17	2- 38d	2- 126a	

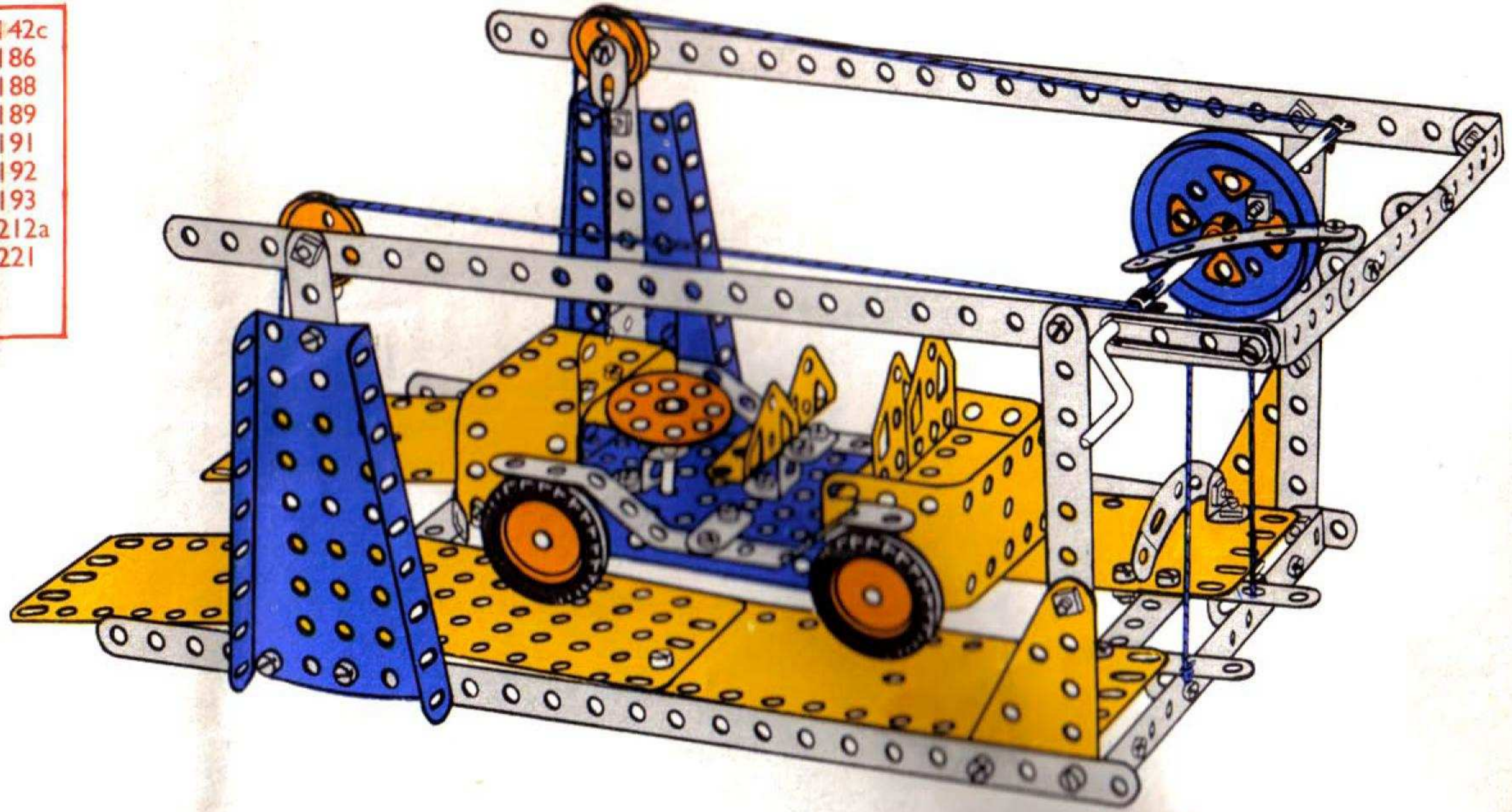

4- 1	1- 20a	6- 48a
6- 2	2- 22a	2- 53a
2- 3	1- 24	2- 54
9- 5	5- 35	3- 90a
2- 10	56- 37a	5- 111c
1- 11	48- 37b	1- 186
2- 12	4- 38	2- 191
1- 15b	2- 38d	2- 192
1- 18b	1- 40	2- 212a
1- 19s	1- 48	2- 221

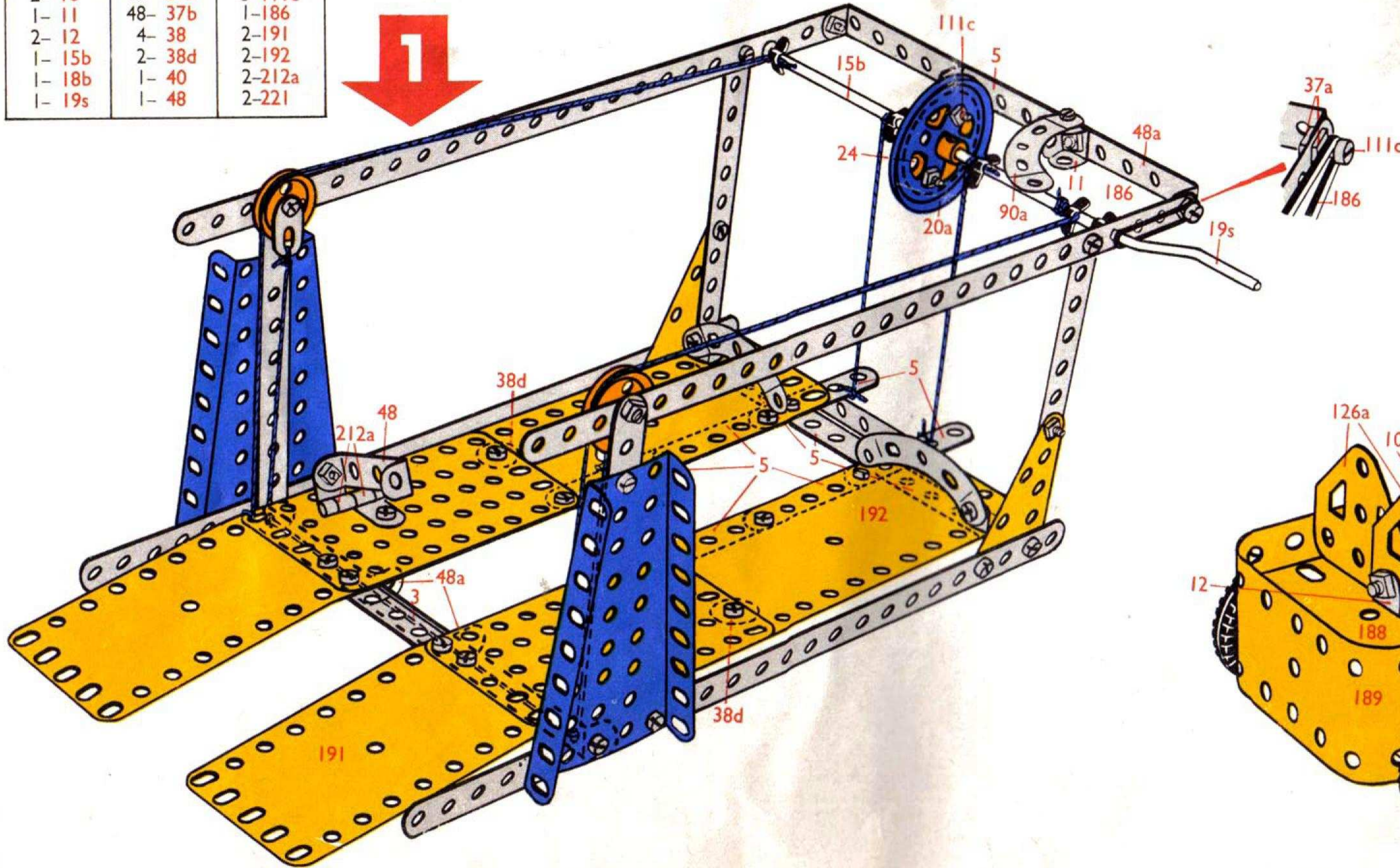

2- 2	4- 22	2- 125
2- 10	1- 24	2- 126
1- 11	2- 35	2- 126a
2- 12	18- 37a	4- 142c
2- 12c	18- 37b	2- 188
2- 16	10- 38	2- 189
1- 17	1- 52	1- 193

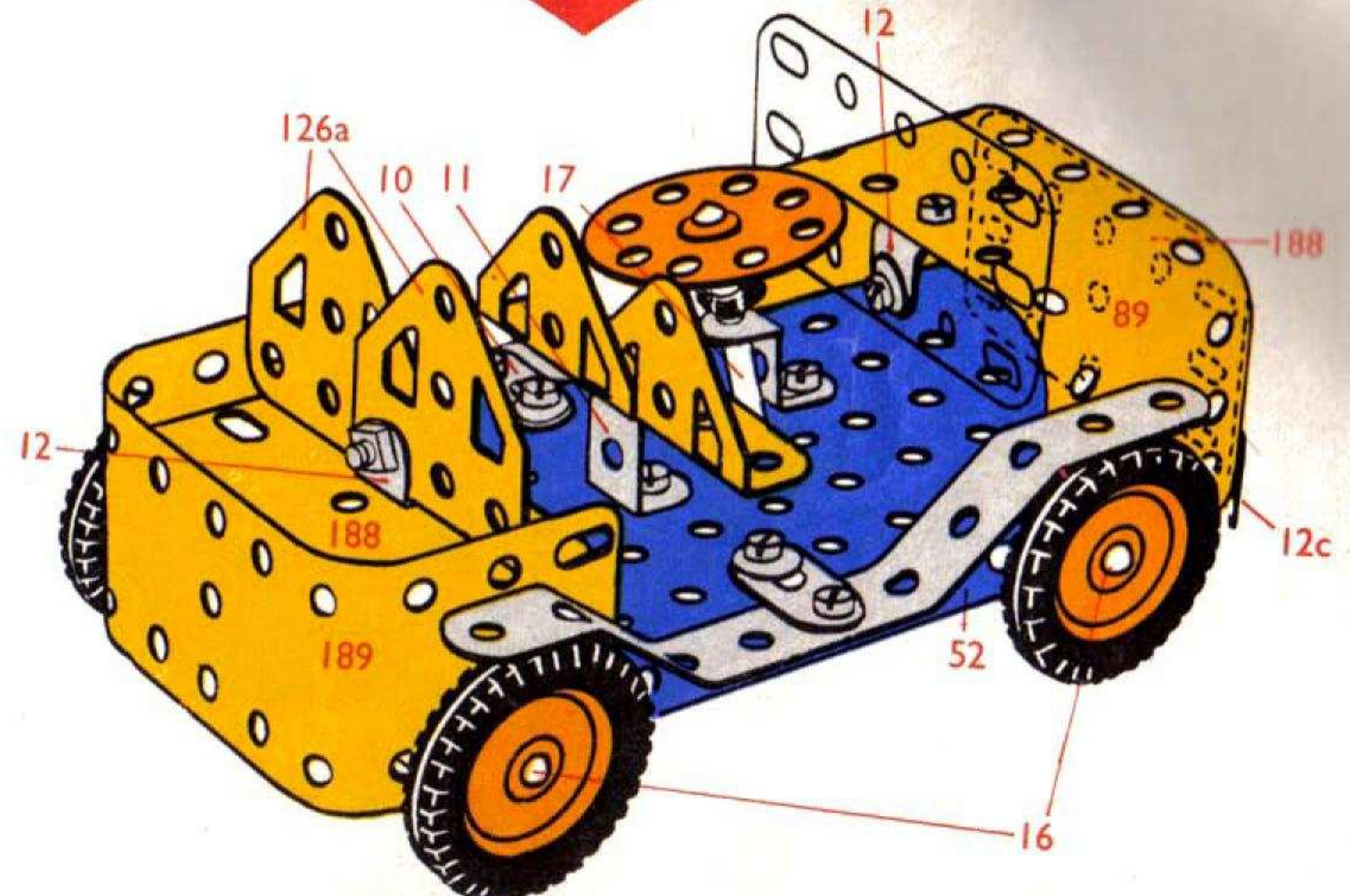

5.6

Jumbo Crane
 Jumbokraan
 Grue géante
 Gru Jumbo
 Jumbo Kran
 Tung lyftkran
 Grúa gigante
 Guindaste gigante
 Jumbo-kran

2-	1	1-	20a	6-	48a	1-	176
8-	2	4-	22	1-	51	4-	187
2-	3	1-	23	1-	52	2-	188
9-	5	1-	23a	2-	54	2-	189
2-	10	2-	24	1-	57c	1-	190
2-	11	2-	27f	2-	90a	2-	191
1-	11a	10-	35	2-	111	2-	194
4-	12	104-	37a	2-	111a	1-	200
2-	15b	88-	37b	1-	111c	1-	212
2-	16	15-	38	2-	126	2-	212a
2-	17	2-	38d	2-	126a	2-	214
2-	18a	1-	40	1-	142c	4-	221
1-	19s	2-	48	2-	155		

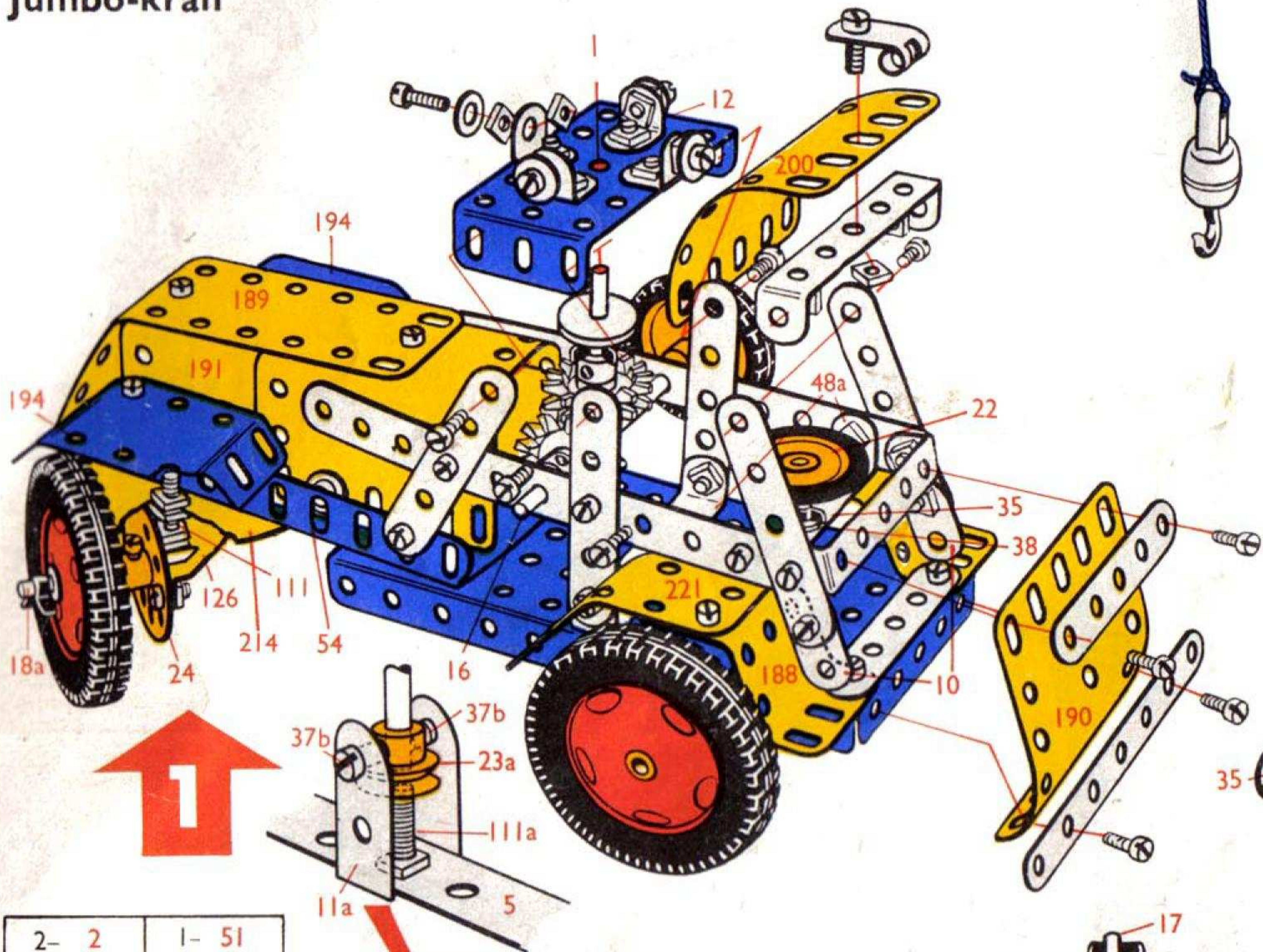

2-	2	1-	51
1-	3	1-	52
8-	5	1-	54
2-	10	2-	90a
4-	12	2-	111
1-	15b	2-	126
1-	16	1-	142c
2-	17	1-	155
2-	18a	4-	187
2-	22	2-	188
2-	24	1-	189
2-	27f	1-	190
5-	35	2-	191
72-	37a	2-	194
62-	37b	1-	200
7-	38	1-	212a
2-	38d	2-	214
1-	48	2-	221
4-	48a		

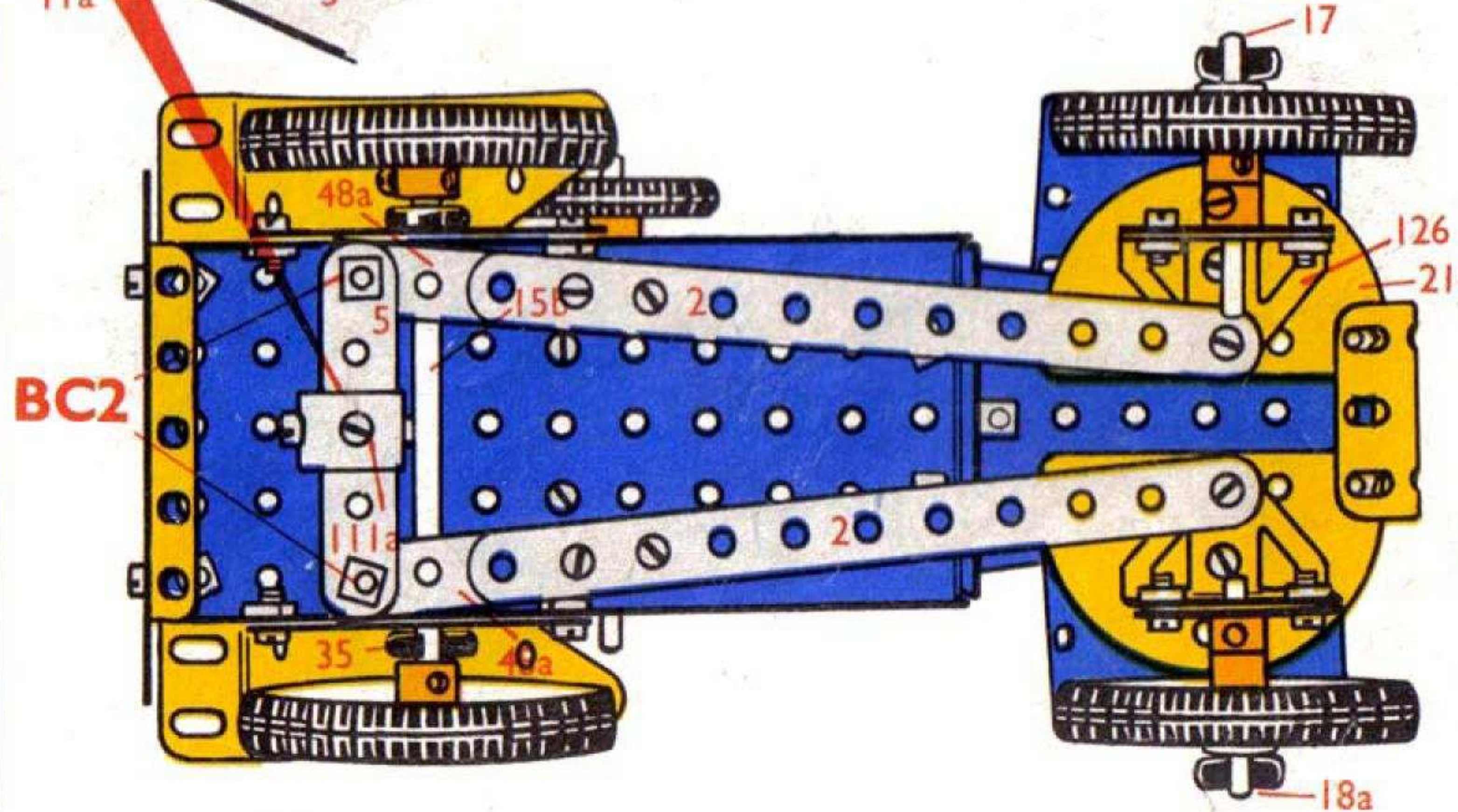

2-	2
1-	5
1-	11a
1-	23a
13-	37a
10-	37b
2-	48a
1-	111a

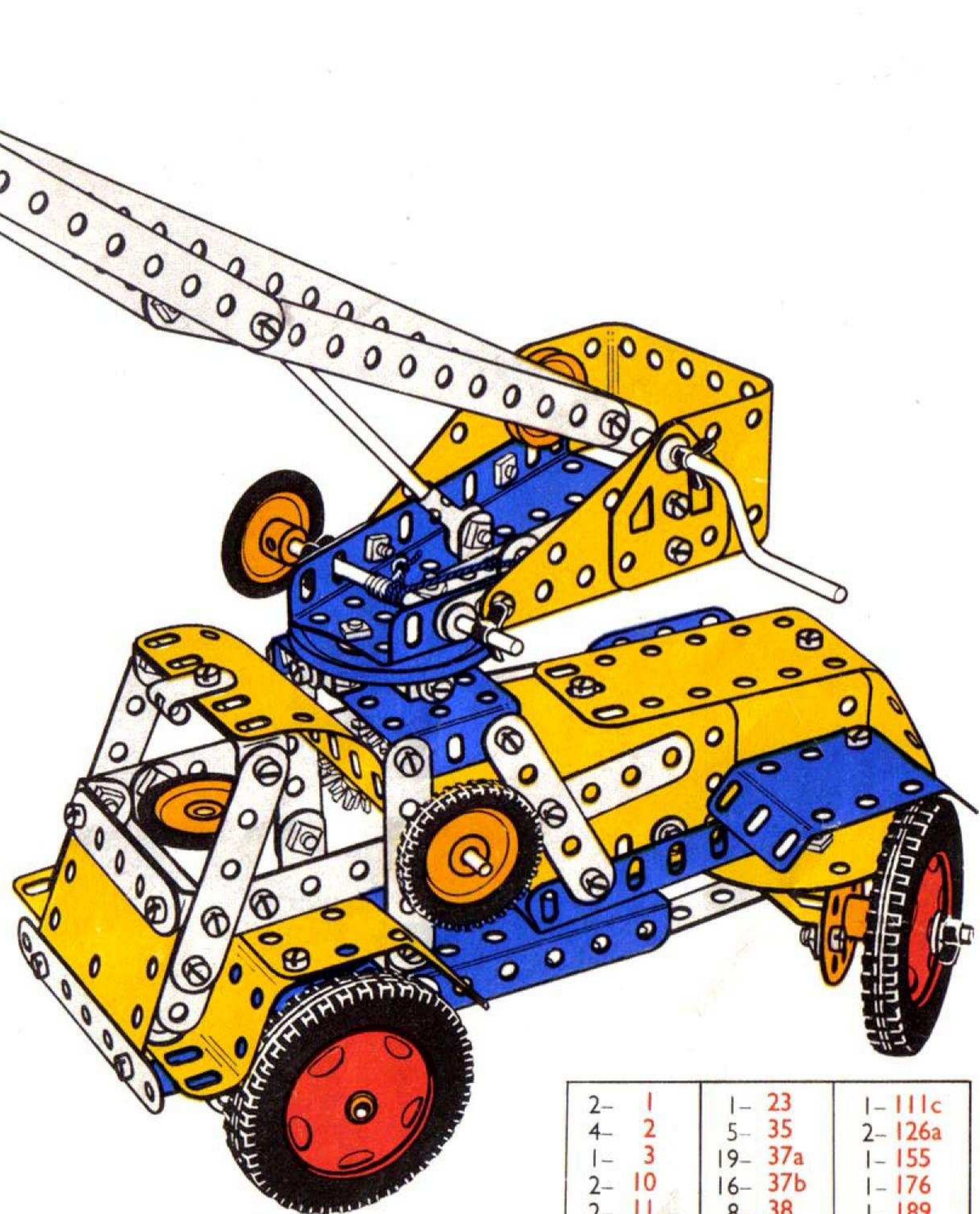

2-	1	1-	23	1-	111c
4-	2	5-	35	2-	126a
1-	3	19-	37a	1-	155
2-	10	16-	37b	1-	176
2-	11	8-	38	1-	189
1-	15b	1-	40	1-	212
1-	16	1-	48	1-	212a
1-	19s	1-	54	2-	221
1-	20a	1-	57c		
2-	22	1-	111a		

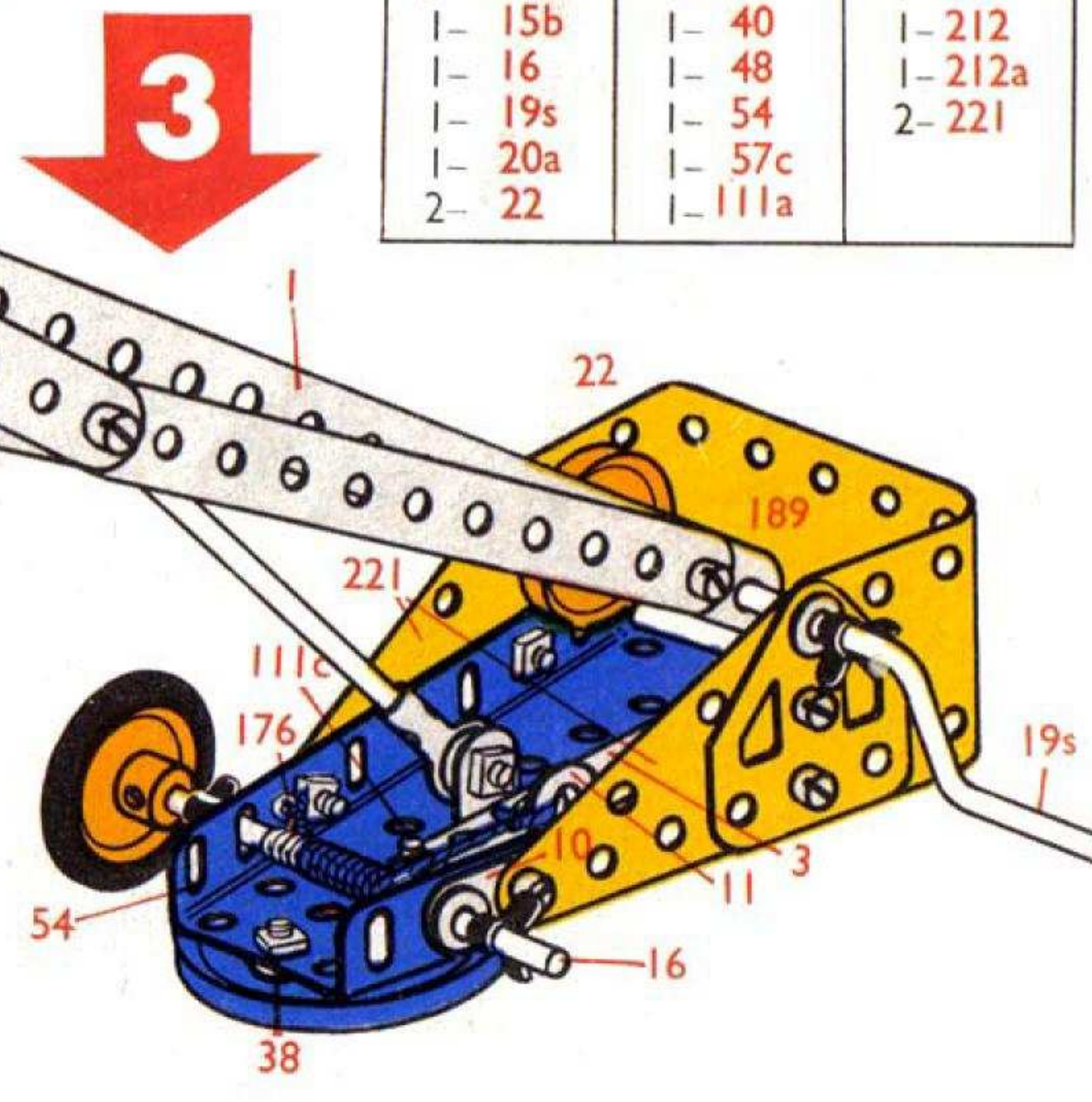

5.7

Loading Shovel
Lepelschop
Pelle de chargement
Motopala
Schaufellader
Skoplastare
Pala cargadora
Pá de cargar
Lasteskuffe

8- 2	1- 19s	1- 52	3-190
2- 3	4- 22	2- 53a	2-191
9- 5	2- 24	2- 54	1-199
1- 10	2- 27f	4- 90a	1-200
2- 11	16- 35	4-111c	1-212
1- 11a	95- 37a	2-125	2-212a
10- 12	93- 37b	2-126	1-213
4- 12c	12- 38	2-126a	2-214
2- 15b	2- 38d	1-155	4-221
4- 16	1- 40	1-176	
2- 17	1- 48	1-186	
2- 18a	6- 48a	4-187	
1- 18b	1- 51	1-188	

2- 2	2- 22	1- 51	1-188
2- 3	1- 24	1- 52	3-190
2- 5	2- 27f	2- 54	2-191
1- 11a	3- 35	2- 90a	1-200
4- 12c	55- 37a	2-111c	1-212
2- 16	53- 37b	2-126	2-212a
1- 18a	4- 38	2-126a	2-214
1- 18b	2- 38d	1-155	
1- 19s	4- 48a	1-176	

5- 5	9- 37b
2- 11	4- 38
2- 16	1- 48a
2- 17	1-111c
1- 24	4-187
7- 35	1-199
10- 37a	1-213

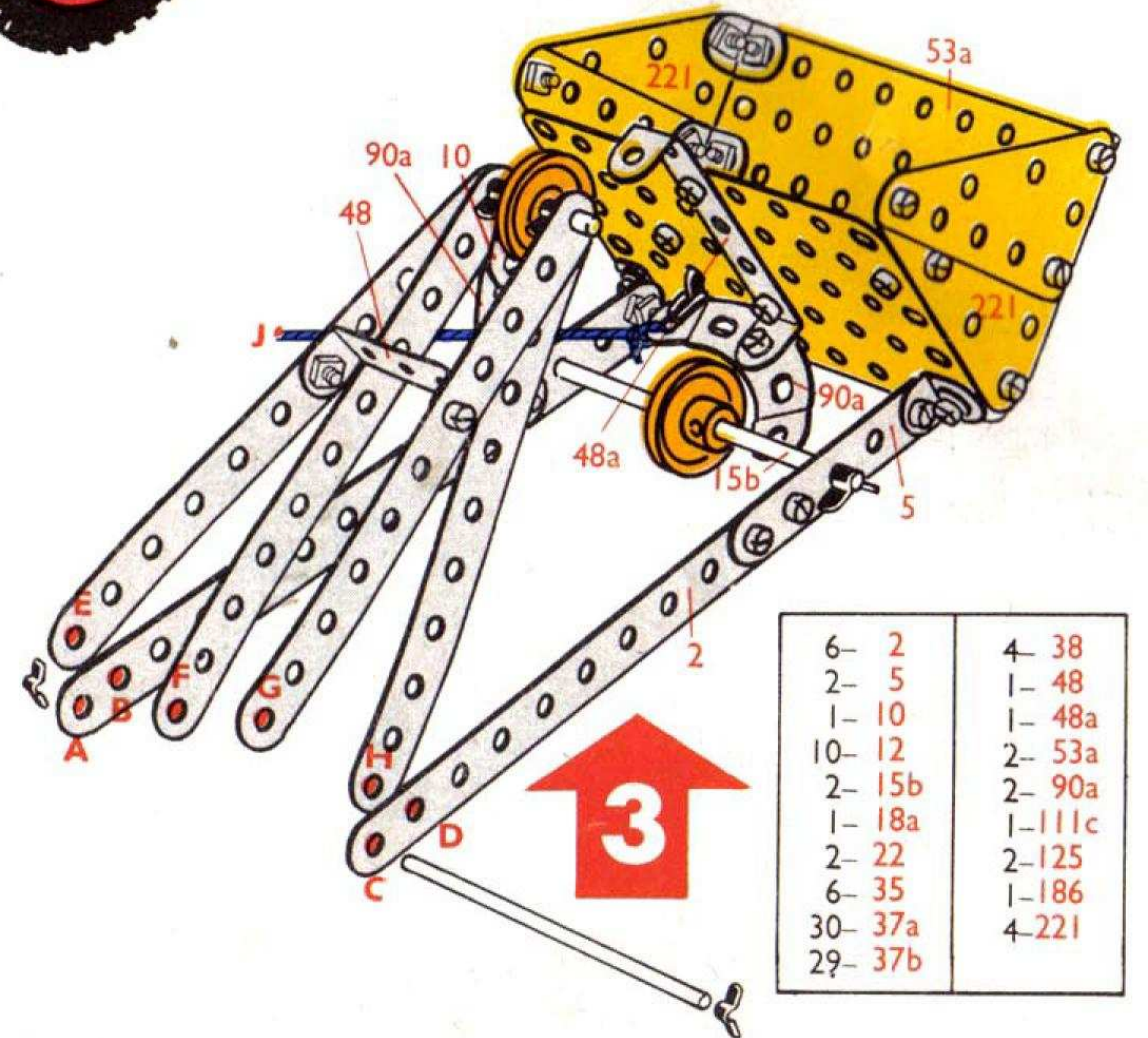
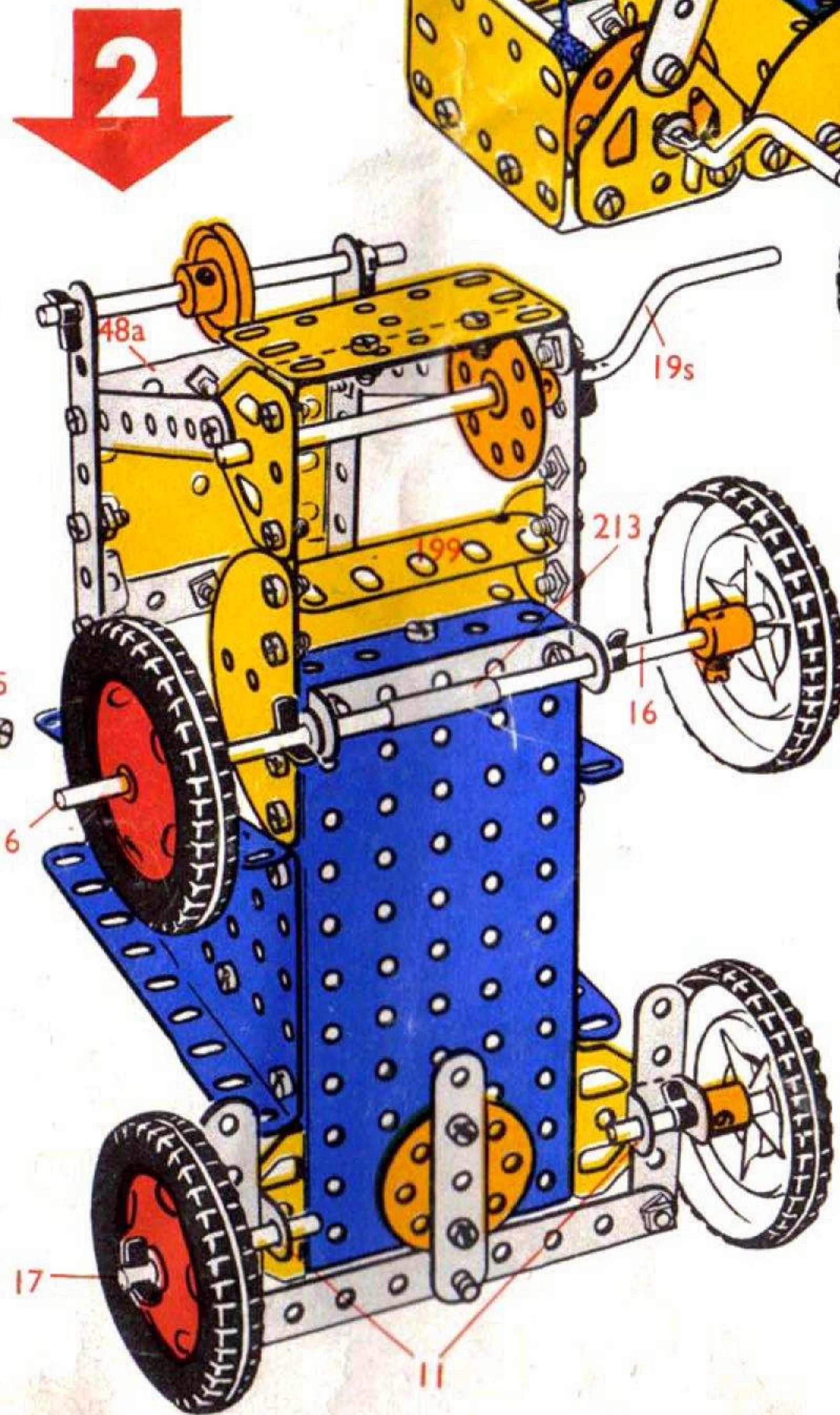
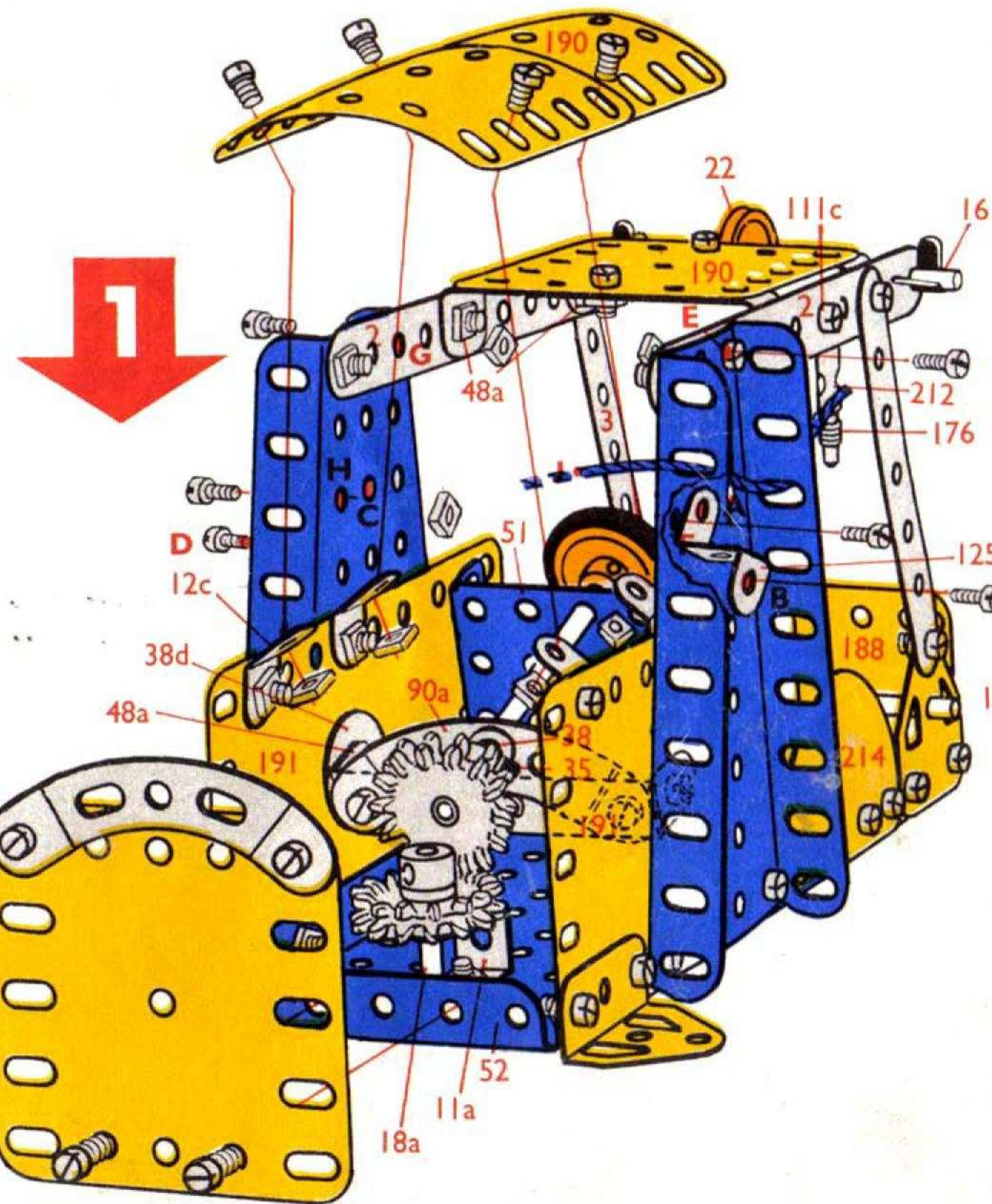
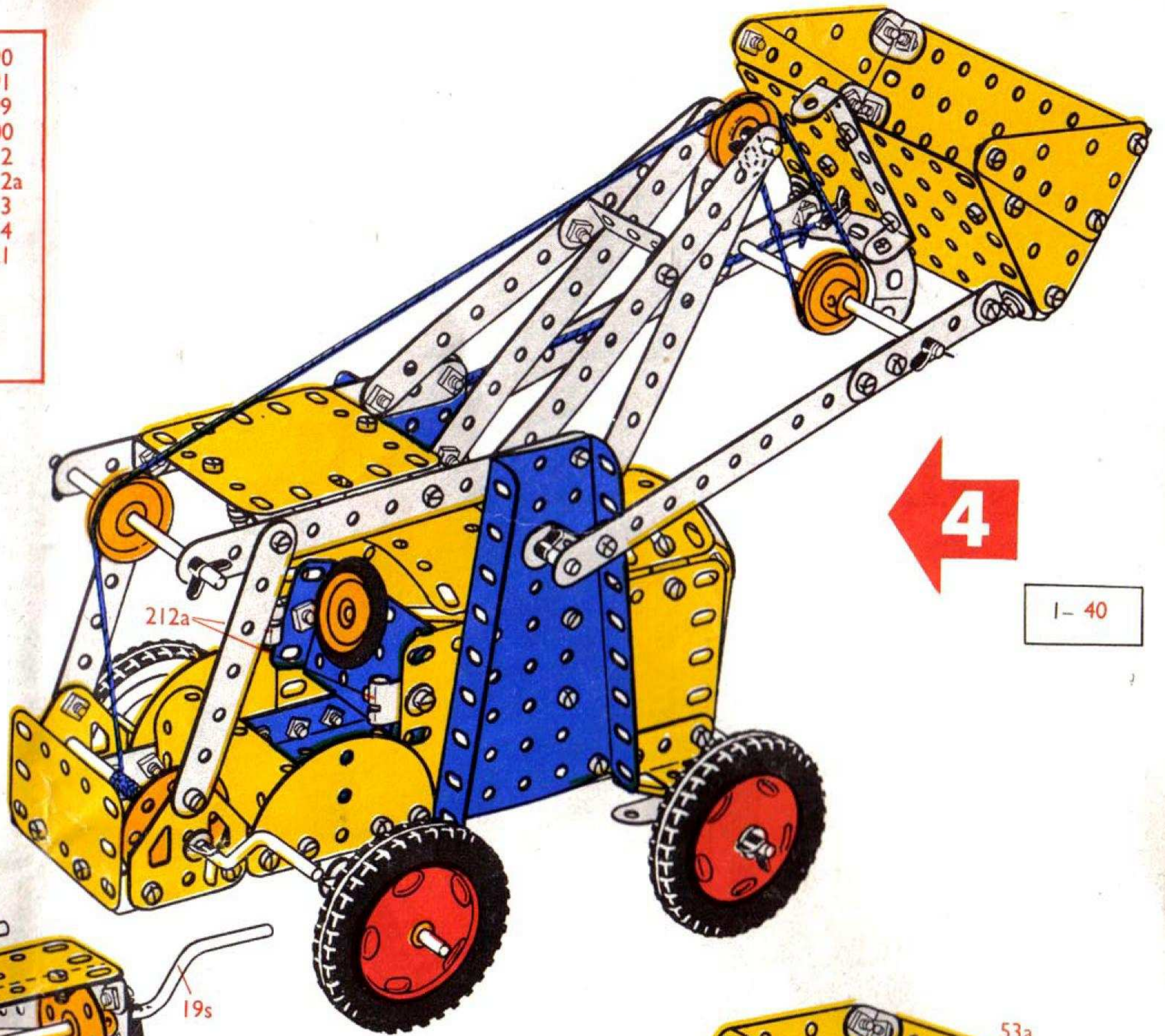

6- 2	4- 38
2- 5	1- 48
1- 10	1- 48a
10- 12	2- 53a
2- 15b	2- 90a
1- 18a	1-111c
2- 22	2-125
6- 35	1-186
30- 37a	4-221
29- 37b	

5.8

Helicopter
 Hefschroefvliegtuig
 Hélicoptère
 Elicottero
 Hubschrauber
 Helikopter
 Helicóptero

4- 1	4- 22	1- 51	1-191
8- 2	2- 22a	2- 54	2-192
2- 3	1- 23	3- 90a	2-193
9- 5	2- 24	2-111	1-193a
1-10	2- 27f	2-125	1-199
1-11a	1- 35	2-126	1-200
5-12	94-37a	2-126a	1-213
4-12c	91-37b	2-142c	2-214
2-15b	11- 38	2-155	4-215
1-16	1- 38d	1-186	4-221
1-18a	1- 40	2-188	
2-19b	1- 48	2-189	
1-20a	4- 48a	3-190	

1- 1	1- 20a	1- 48	1-186
1- 2	3- 22	4- 48a	2-188
2- 3	2- 22a	1- 51	3-190
4- 5	1- 23	2- 54	2-193
1-11a	2- 27f	3- 90a	1-193a
3-12	1- 35	1-111	1-200
4-12c	54-37a	2-125	1-213
2-15b	52-37b	2-126	2-214
1-16	7- 38	2-126a	3-215
1-18a	1- 38d	2-142c	4-221
2-19b	1- 40	2-155	

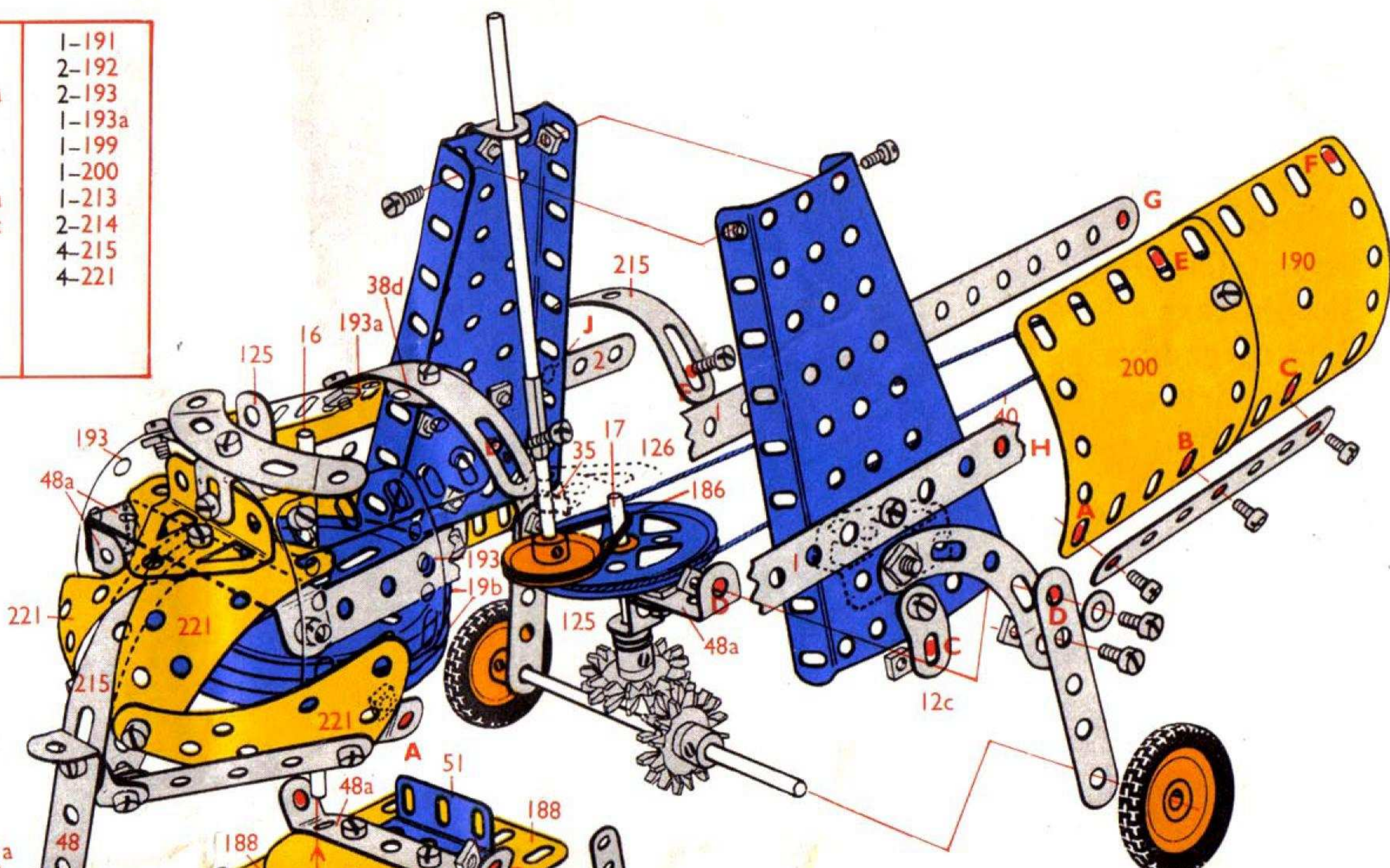
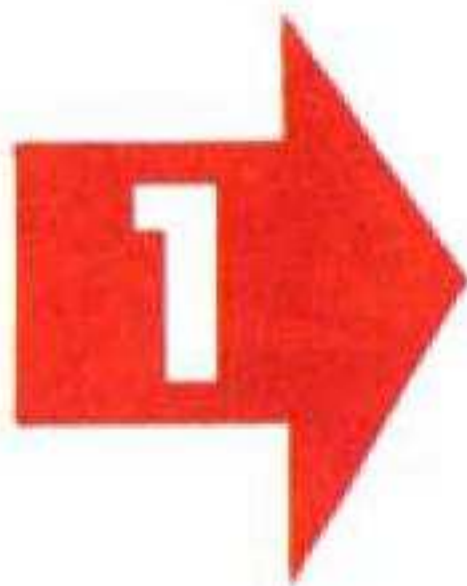

3- 1	4- 38
1- 2	1-111
2- 5	2-189
1-10	1-191
2-12	2-192
1-22	1-199
25-37a	1-215
24-37b	

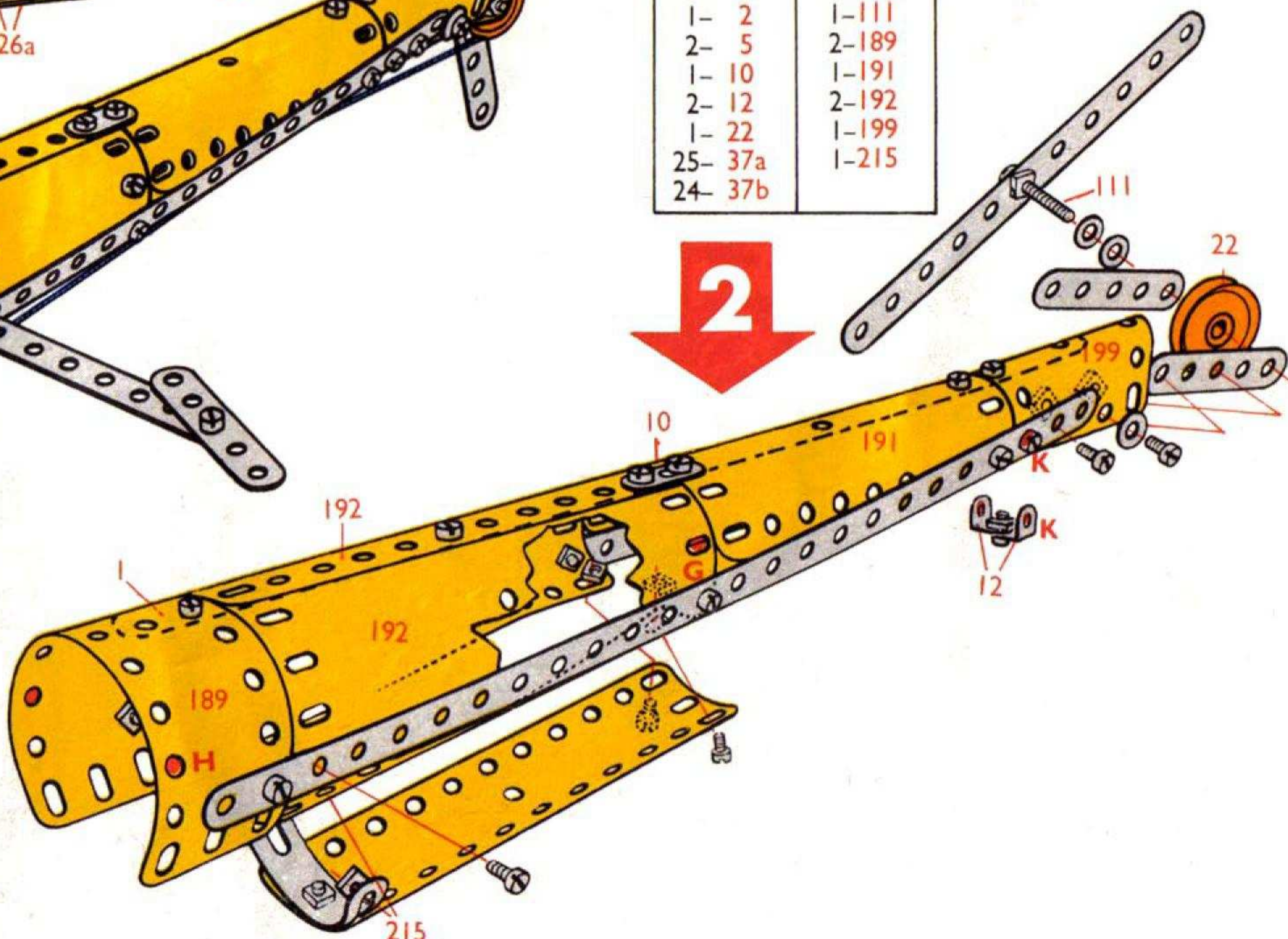

6- 2
3- 5
2- 24
15-37a
15-37b

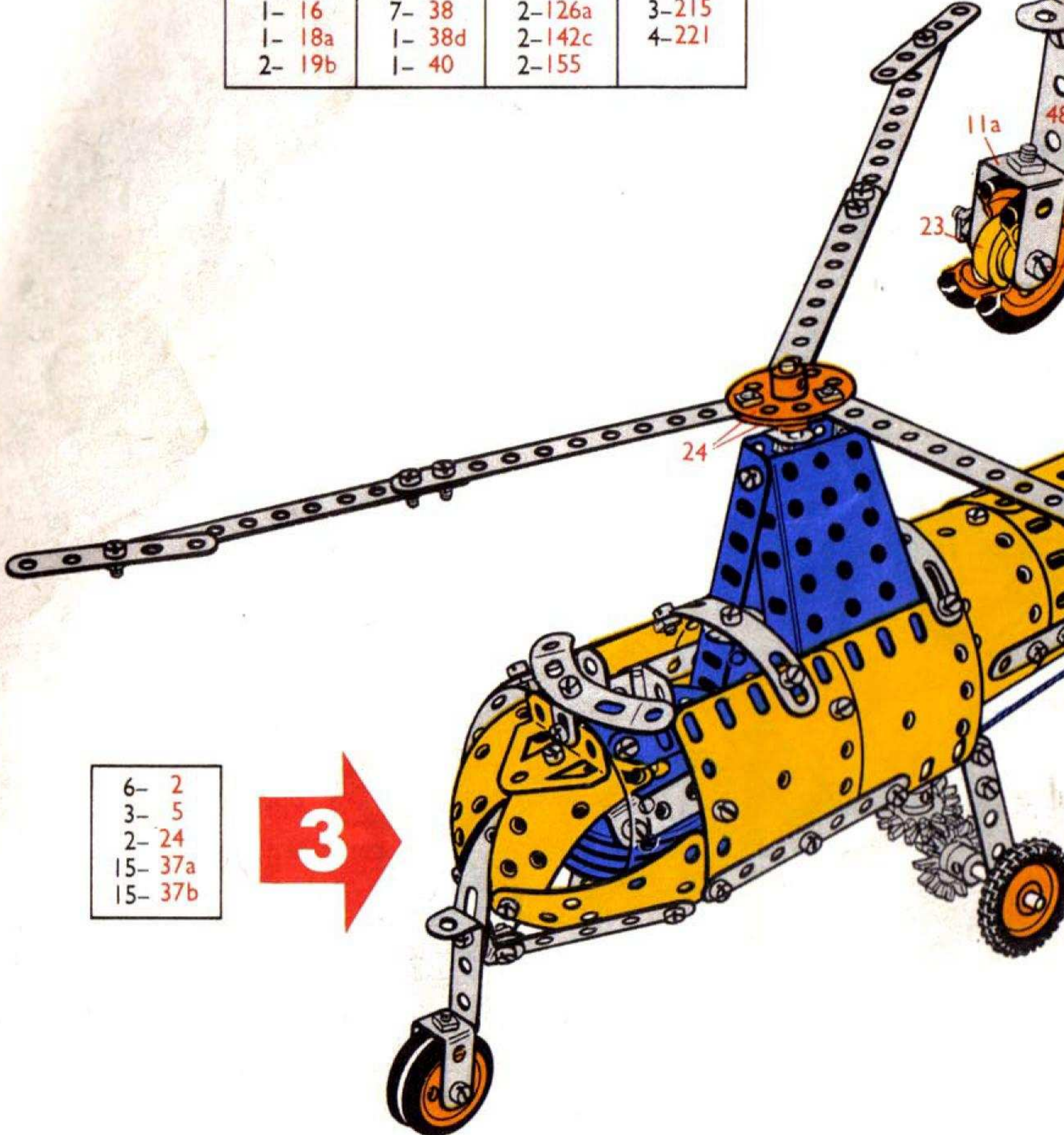

5.9

Construction Crane with Grab
 Constructiekraan met grijper
 Grue de construction avec benne preneuse
 Gru per cantiere con benna
 Baukran mit Greifer
 Byggnadskran med gripanordning
 Grúa para obras, con bivalva
 Guindaste de construção com garras
 Kran med grabb

4- 1	1- 19s	2- 38d	2- 126a
8- 2	1- 20a	1- 40	1- 176
2- 3	4- 22	2- 48	1- 186a
9- 5	2- 22a	6- 48a	*1- 186b
4- 10	1- 23	1- 51	2- 187
2- 11	*1- 23a	1- 52	2- 188
1- 11a	1- 23a	2- 53a	2- 189
10- 12	2- 24	2- 54	1- 190
1- 12c	2- 27f	4- 90a	1- 200
2- 15b	16- 35	2- 111	2- 212a
4- 16	103- 37a	2- 111a	1- 213
2- 17	93- 37b	2- 111c	2- 221
2- 19b	14- 38	2- 126	*1- M5

* Not included in set No. 5



6- 2
2- 5
2- 10
4- 12
1- 12c
2- 17
2- 22
1- 23
2- 35
25- 37a
23- 37b
1- 48
1- 48a
3- 90a
2- 111c
2- 126
1- 190
1- 200
2- 212a

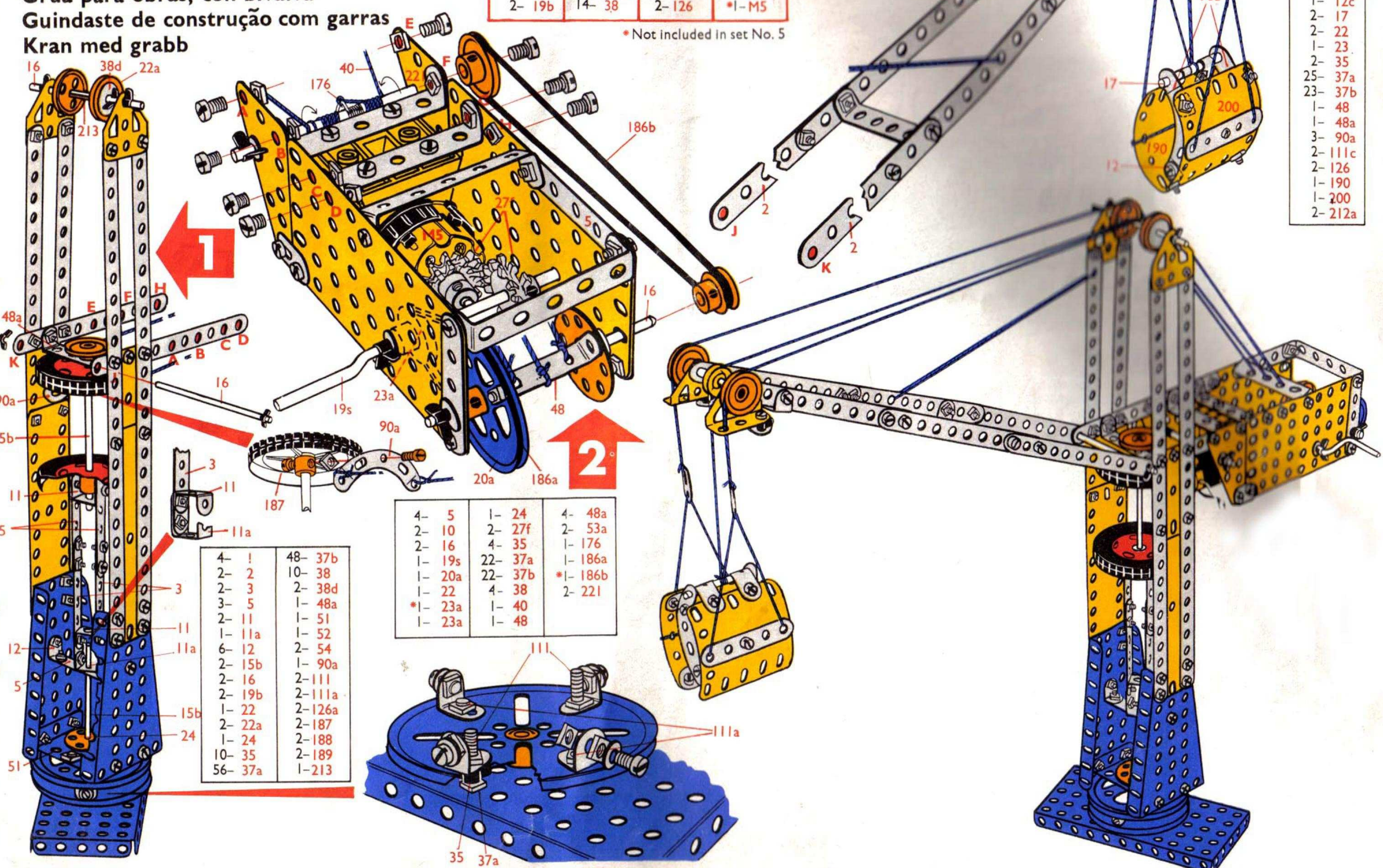

4- 1	48- 37b
2- 2	10- 38
2- 3	2- 38d
3- 5	1- 48a
2- 11	1- 51
1- 11a	1- 52
6- 12	2- 54
2- 15b	1- 90a
2- 16	2- 111
2- 19b	2- 111a
1- 22	2- 126a
2- 22a	2- 187
1- 24	2- 188
10- 35	2- 189
56- 37a	1- 213

4- 5	1- 24	4- 48a
2- 10	2- 27f	2- 53a
2- 16	4- 35	1- 176
1- 19s	22- 37a	1- 186a
1- 20a	22- 37b	*1- 186b
1- 22	4- 38	2- 221
*1- 23a	1- 40	
1- 23a	1- 48	

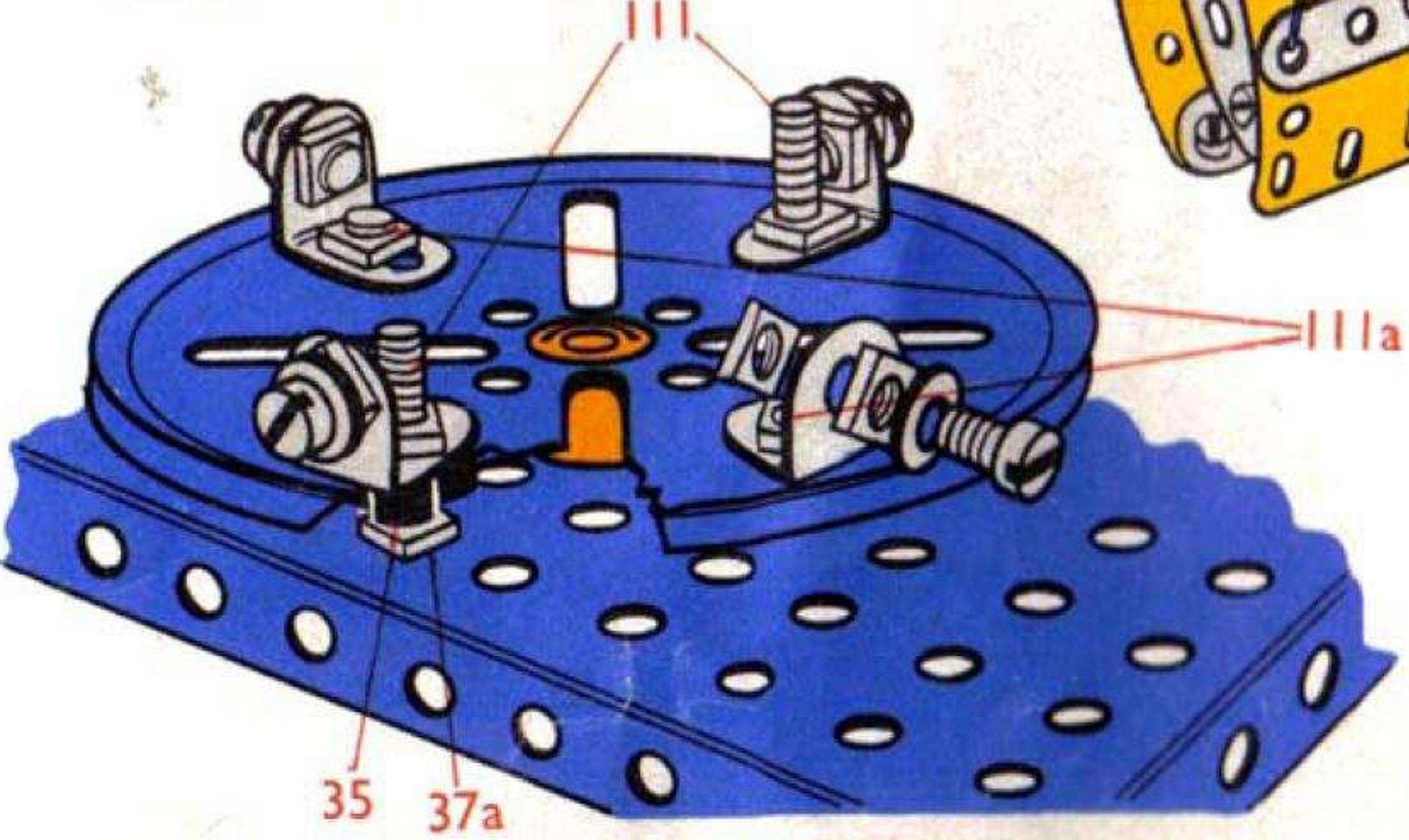

5.10

Diesel Electric Locomotive
Diesel-elektrische locomotief
Locomotive électrique Diesel
Locomotore diesel/eletrico
Elektro-Diesel-Lokomotive
Dieselektriskt lok
Locomotora diesel eléctrica
Locomotiva Diesel eléctrica
Diesel-lokomotiv

2-	1	32-	37b
2-	2	1-	38
4-	5	2-	38d
4-	10	2-	48a
1-	11a	1-	51
1-	12	1-	52
1-	16	3-	111c
*1-	23a	2-	126
1-	24	2-	126a
2-	35	1-	212
40-	37a		

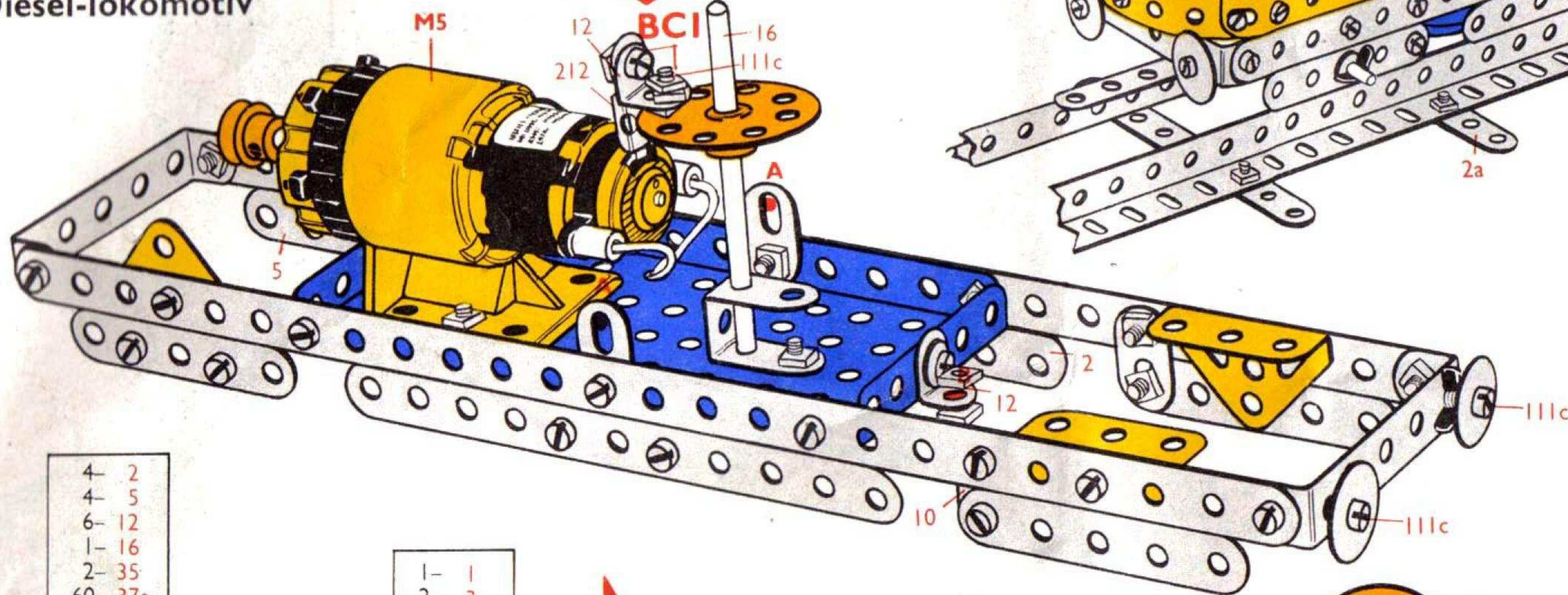
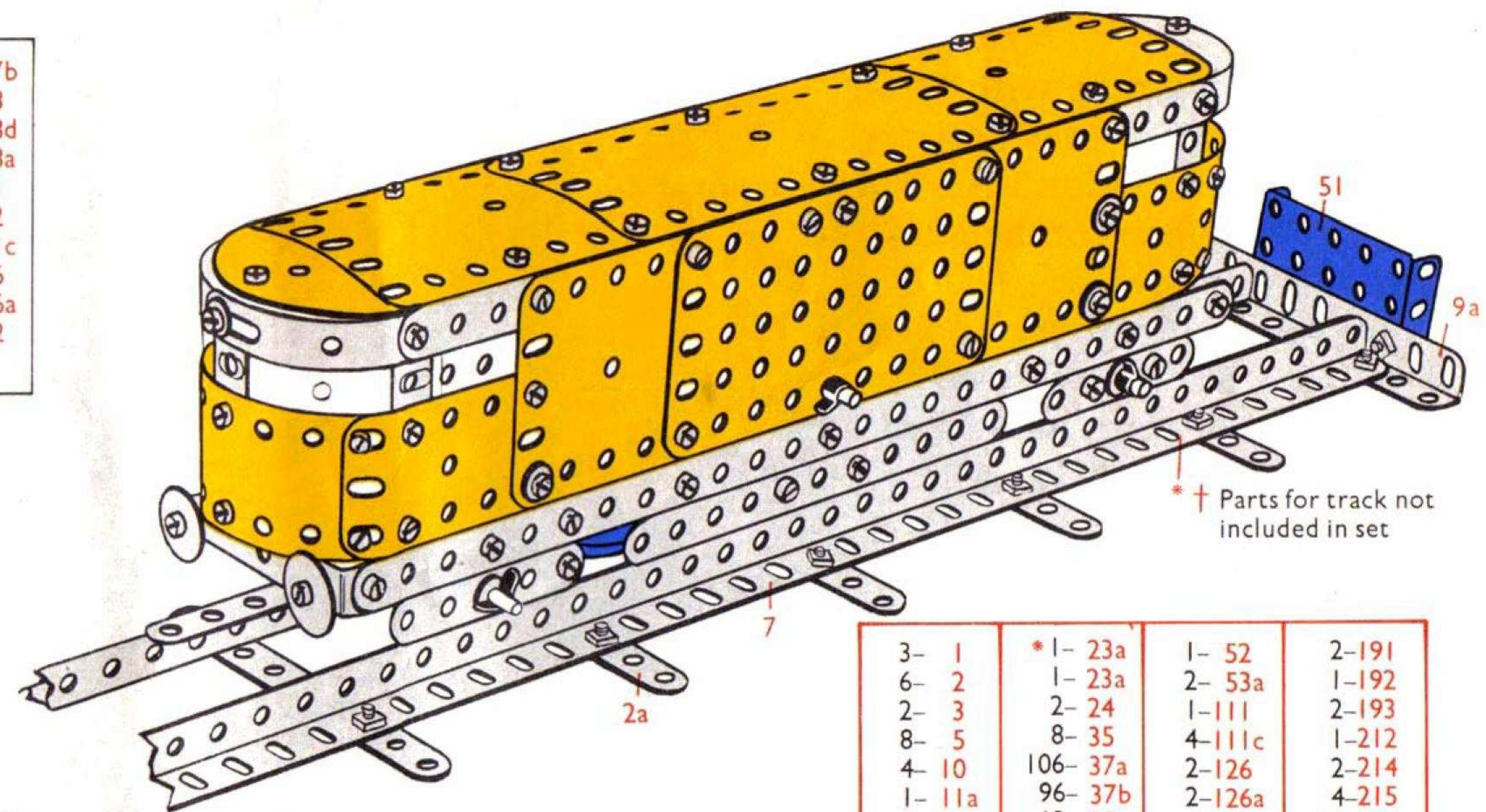

3-	1	*1-	23a	1-	52	2-	191
6-	2	1-	23a	2-	53a	1-	192
2-	3	2-	24	1-	111	2-	193
8-	5	8-	35	4-	111c	1-	212
4-	10	106-	37a	2-	126	2-	214
1-	11a	96-	37b	2-	126a	4-	215
7-	12	13-	38	1-	186	*	1-M5
4-	16	2-	38d	2-	188		
1-	20a	6-	48a	2-	189		
4-	22	1-	51	4-	190		

* Not included in set No. 5

4-	2
4-	5
6-	12
1-	16
2-	35
60-	37a
60-	37b
8-	38
4-	48a
2-	53a
2-	188
2-	189
4-	190
2-	191
1-	192
2-	193
2-	214
4-	215

1-	1
2-	3
2-	16
1-	20a
4-	22
1-	23a
1-	24
4-	35
6-	37a
3-	37b
4-	38
1-	111
1-	111c
1-	186

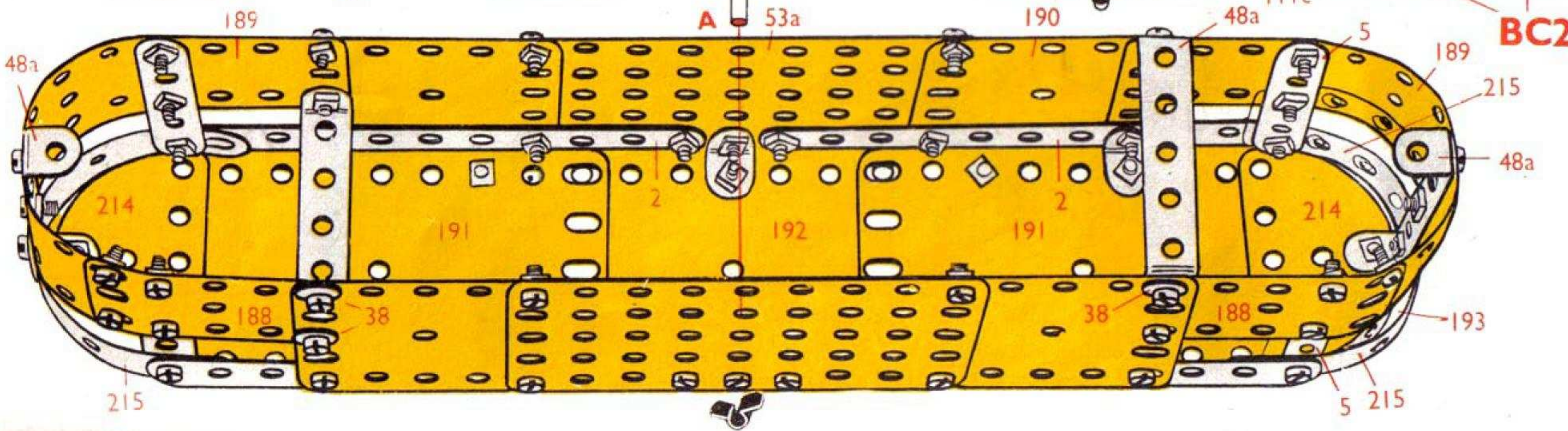
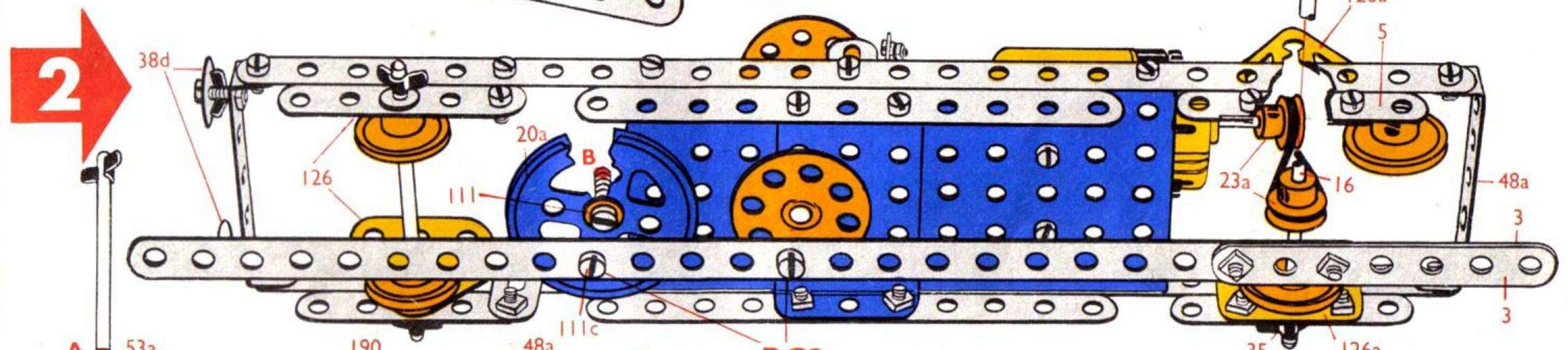

Parts for 24½" (62cm) Track not included in set.
 Onderdelen voor 62cm. spoor zijn niet inbegrepen bij de set.
 Les pièces pour le circuit de 24½" (62cm) ne sont pas comprises.
 I pezzi per il cingolo di 62cm. non sono inclusi nella serie.
 Teile für 62cm Spur sind in diesem Satz nicht enthalten.
 Delar till 62cm spår ingår ej i satsen.
 Las piezas para vía de 62cm (24½") no van incluidas en el juego.
 Peças para vias de 62cm (24½") nao estao incluidas no jogo.
 Deler til 62cm spor er ikke inkludert i settet.

Part No.	2a	7	9a	37a	37b	51
† Quantity	7	2	2	22	22	2

5.11

Traction Engine
 Tractiewagen
 Moteur de traction
 Motore di trazione
 Zugmaschine
 Lokomobil
 Máquina de tracción
 Motor de tracção

8- 2	4- 22	2- 48	*1-186a
2- 3	2- 22a	6- 48a	1-186a
8- 5	1- 23	1- 52	2-187
2- 11	*1- 23a	2- 53a	2-188
1- 11a	1- 23a	1-111	3-190
10-12	2- 24	2-111c	2-191
4- 12c	2- 27f	2-125	2-192
2- 15b	7- 35	2-126	1-194a
4- 16	97- 37a	2-126a	1-199
2- 17	85- 37b	1-142c	1-212
1- 18a	10- 38	1-155	*1-M4
2- 19b	2- 38d	1-176	
1- 20a	1- 40	1-186	

* Not included in set No. 5

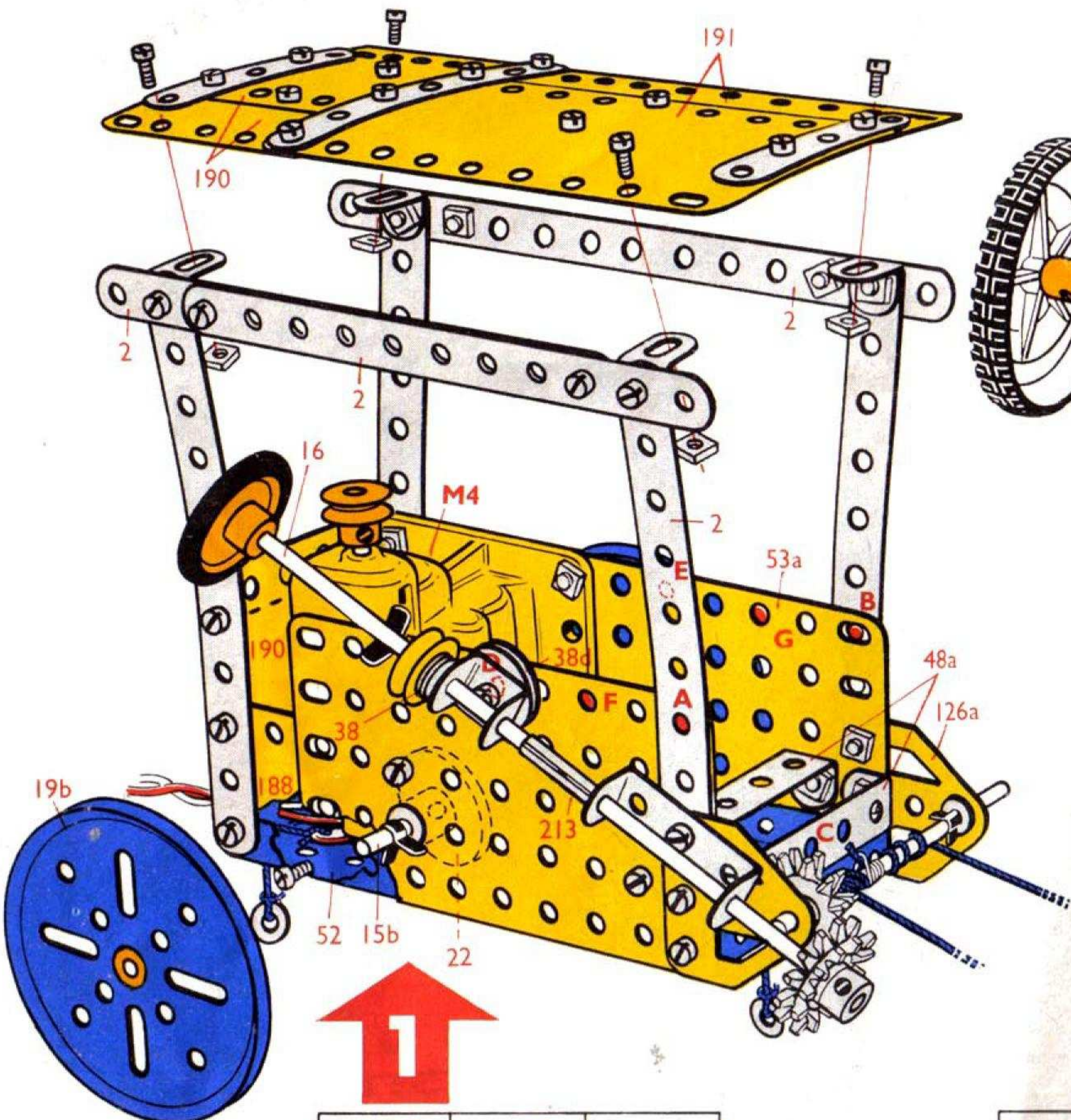

8- 2	1- 23a	1- 52
1- 3	2- 27f	2- 53a
3- 5	4- 35	2-126a
1- 11	52- 37a	1-155
6- 12	52- 37b	1-176
1- 15b	10- 38	2-188
3- 16	2- 38d	3-190
2- 19b	1- 40	2-191
2- 22	1- 48	
1- 23	2- 48a	

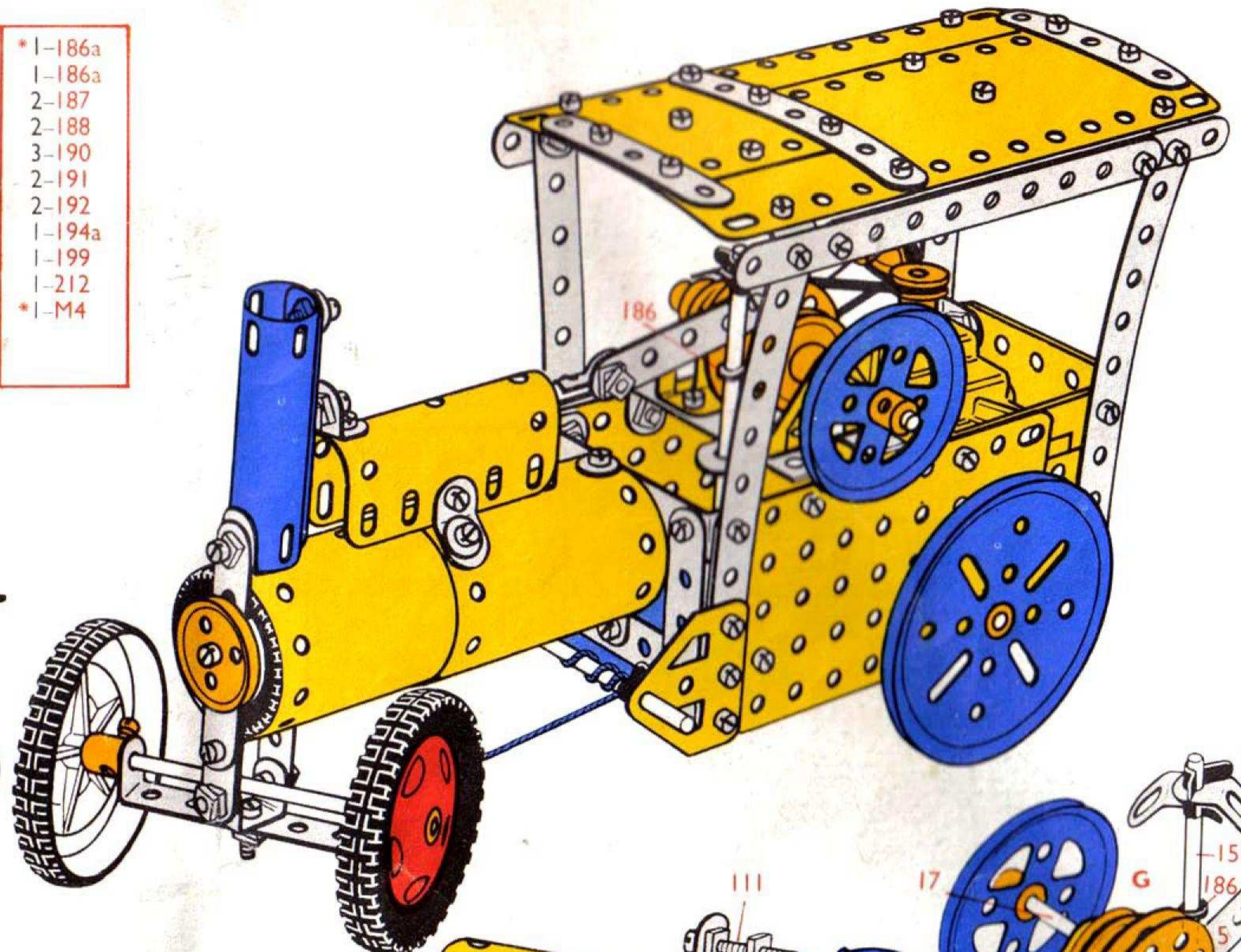

1- 3	1- 48
3- 5	1- 48a
1- 11	1-111
1- 11a	1-111c
4- 12	2-125
2- 12c	1-142c
1- 16	2-187
2- 22a	2-192
32- 37a	1-194a
24- 37b	1-199

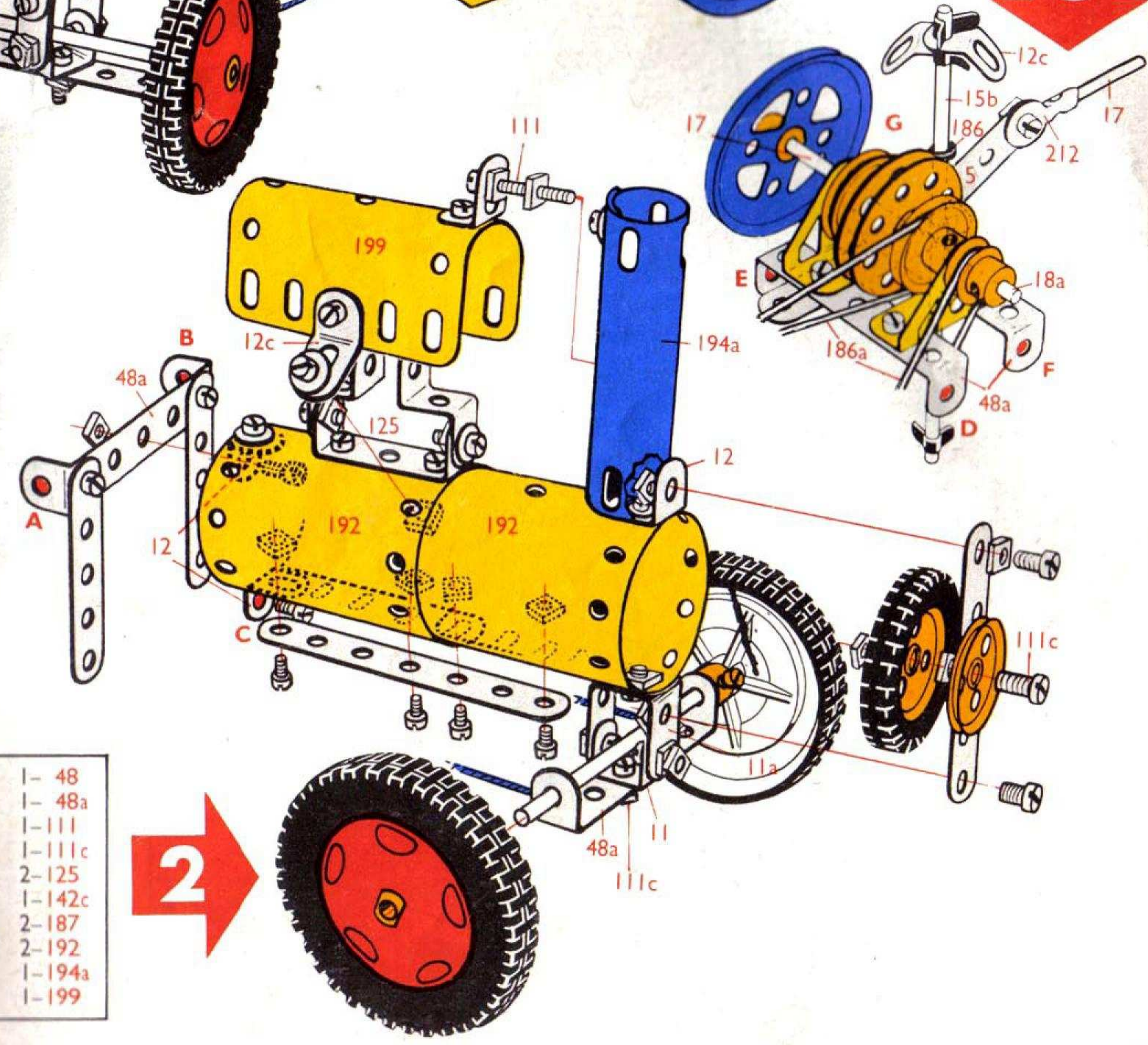

2- 5
2- 12c
1- 15b
2- 17
1- 18a
1- 20a
2- 22
*1- 23a
2- 24
3- 35
13- 37a
9- 37b
2- 48a
1-111c
2-126
1-186
*1-186a
1-186a
1-212



5.12

Dumper Truck
 Stortwagen
 Dumper
 Ribaltabile
 Kipplaster
 Tipptruck
 Camión volquete
 Carrinho basculante
 Dumperbil

2- 2	1- 20a	6- 48a	*1-186b
2- 3	4- 22	1- 51	2-187
9- 5	2- 22a	2- 53a	2-188
4- 10	1- 23	2- 54	2-189
2- 11	*1- 23a	4- 90a	2-191
1- 11a	1- 23a	2-111	1-192
10-12	2- 24	5-111c	1-212
2- 15b	15- 35	2-125	2-212a
4- 16	91- 37a	2-126	2-214
1- 17	79- 37b	2-126a	2-221
1- 18a	14- 38	2-142c	*1-M4
1- 18b	2- 48	1-155	

* Not included in set No. 5

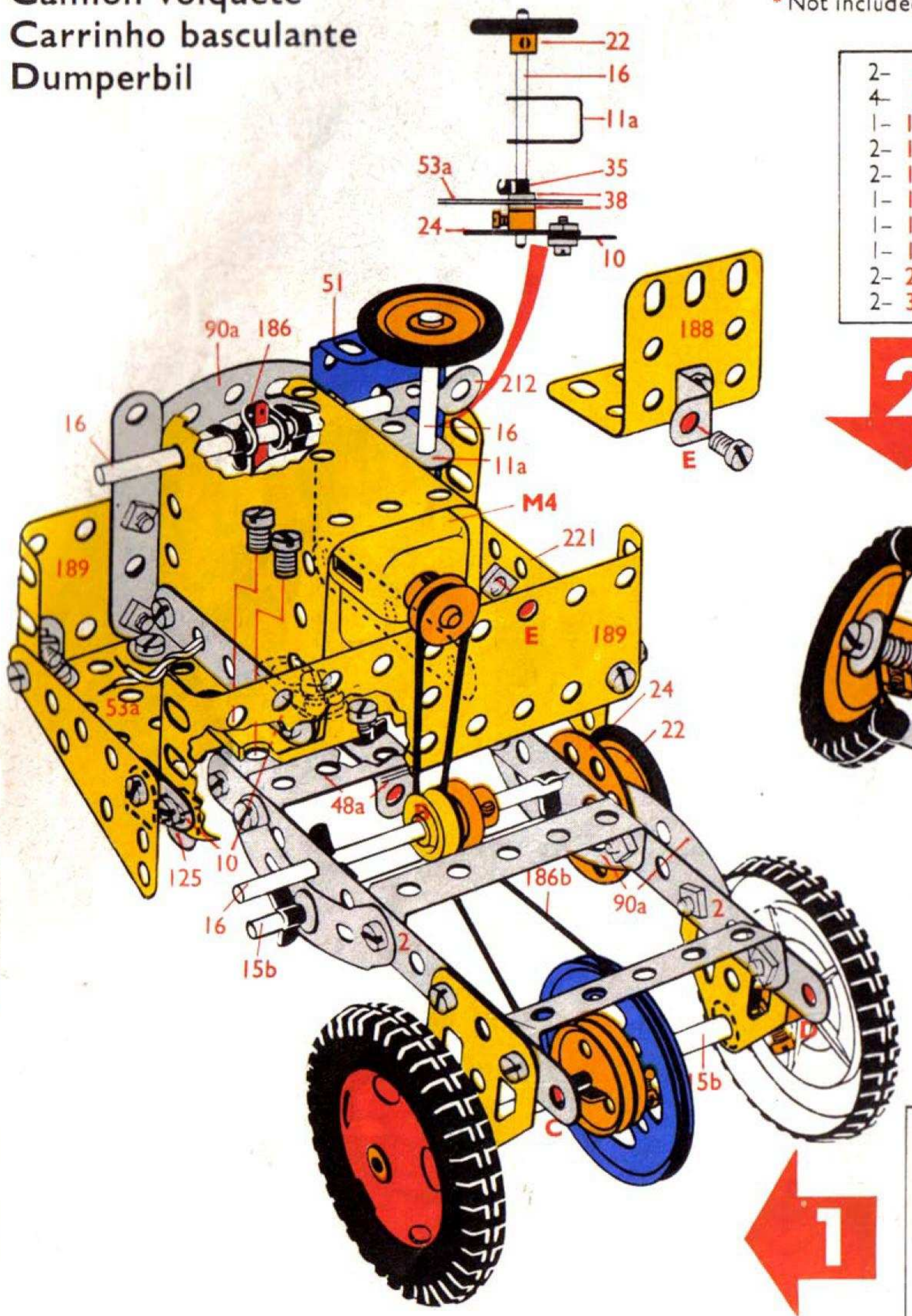

2- 3	25- 37a
4- 5	17- 37b
1- 10	2- 38
2- 11	1- 48
2- 12	2-111
1- 17	2-126
1- 18a	2-142c
1- 18b	2-212a
2- 22	1-214
2- 35	

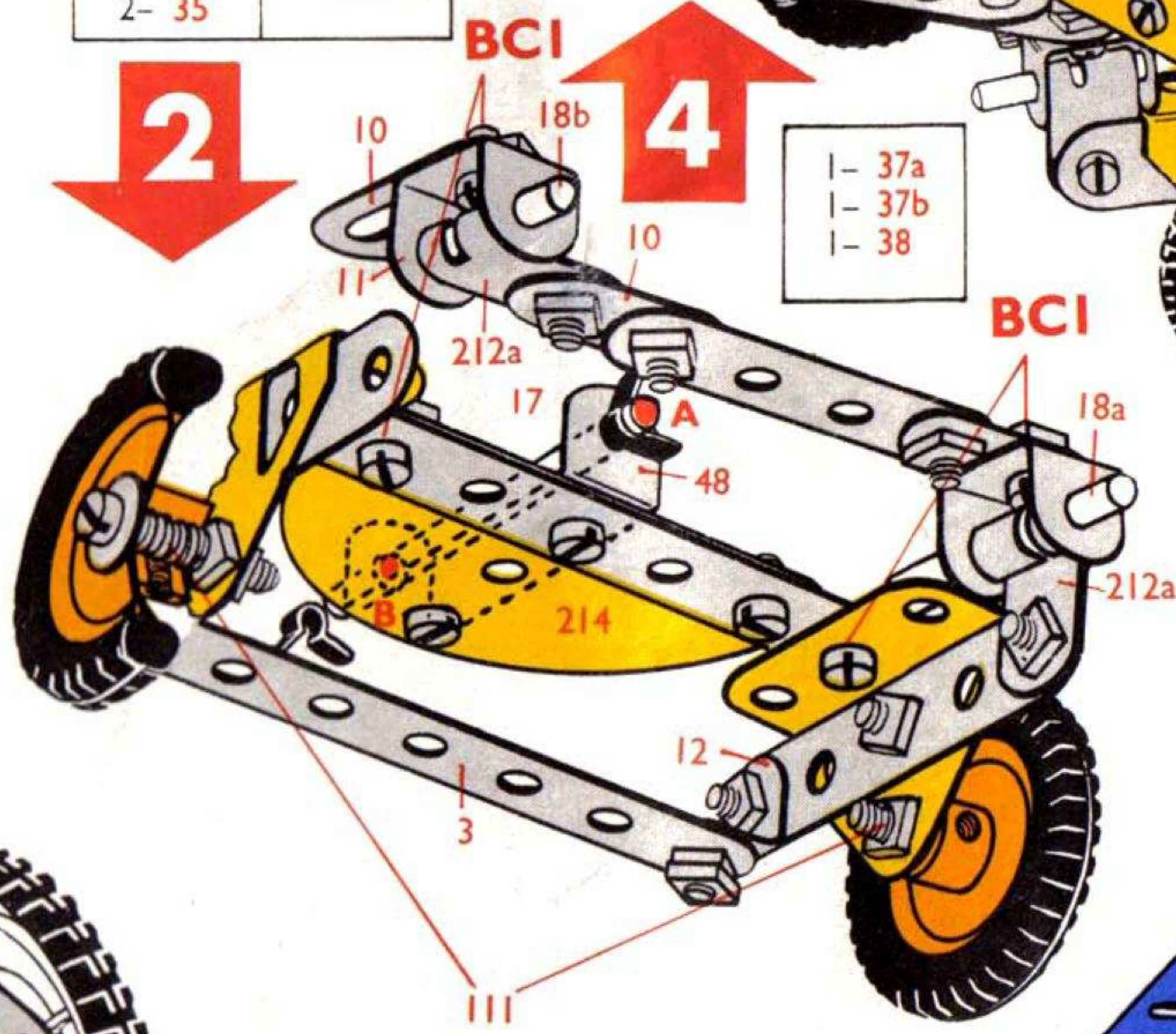

1- 37a
1- 37b
1- 38

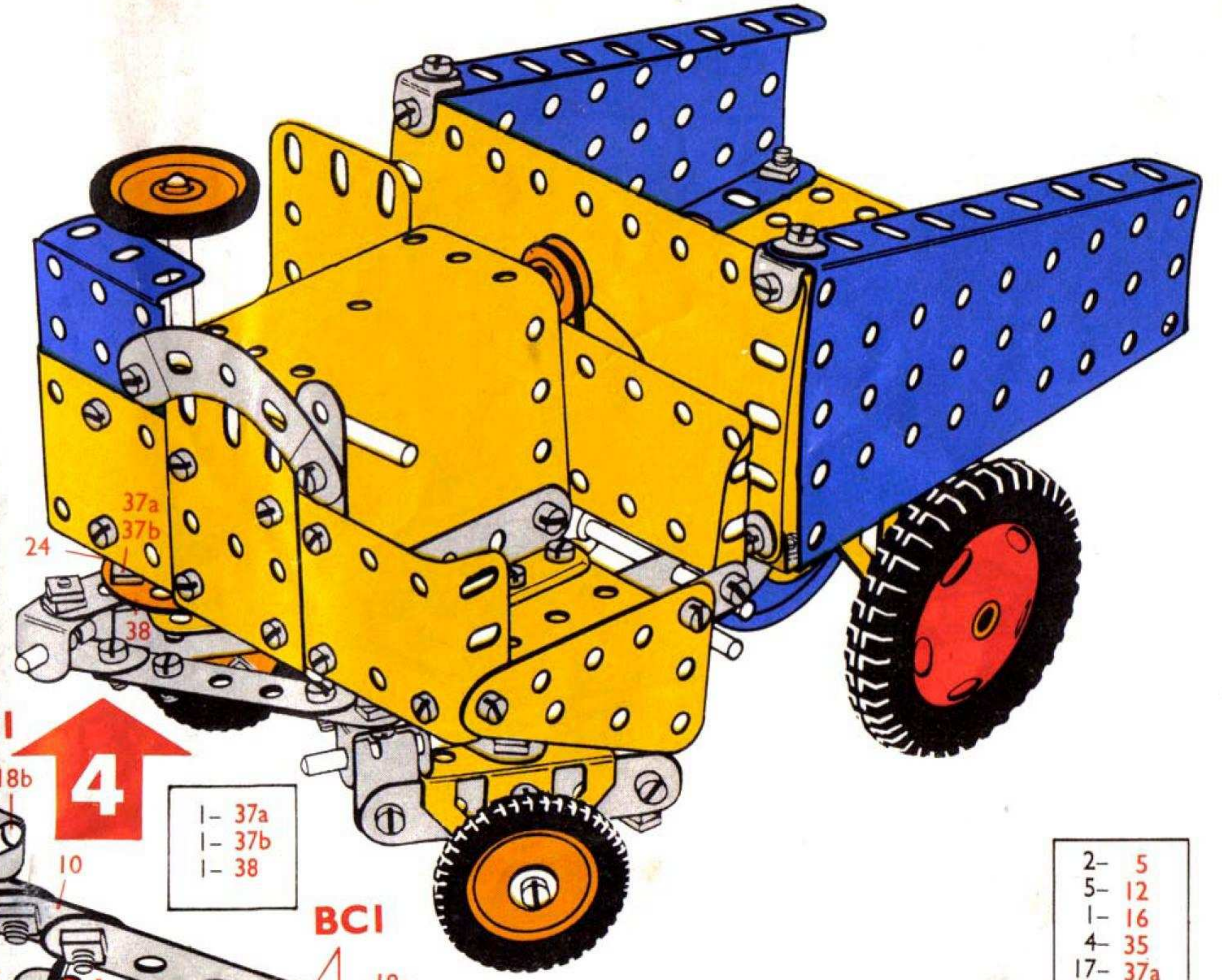

2- 5
5- 12
1- 16
4- 35
17- 37a
15- 37b
6- 38
1- 48a
1- 53a
2- 54
2-111c
2-191
1-214

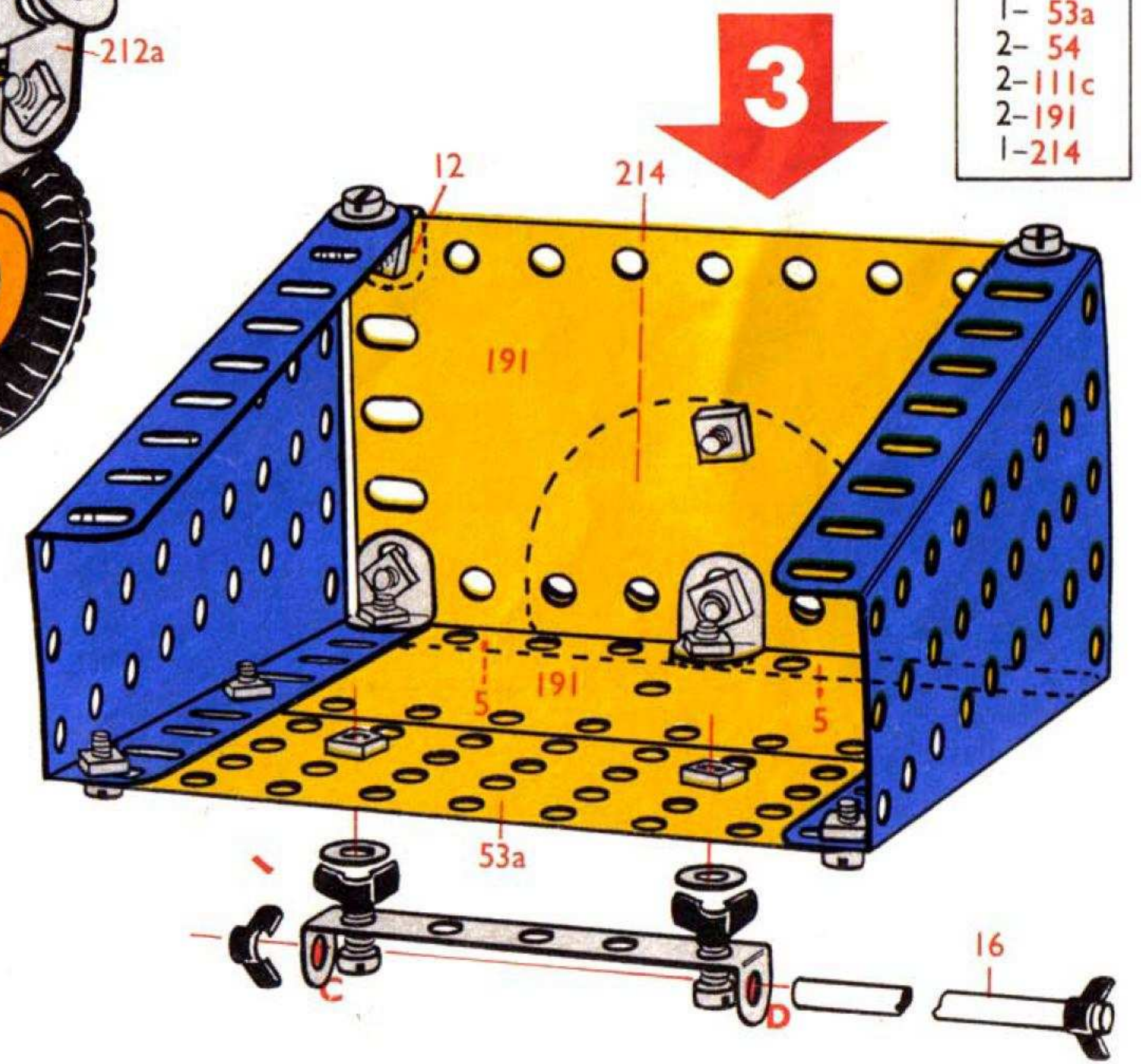

2- 2	1- 23a	2-125
3- 5	2- 24	2-126a
3- 10	9- 35	1-155
1- 11a	48- 37a	*1-186b
3- 12	46- 37b	2-187
2- 15b	6- 38	2-188
3- 16	1- 48	2-189
1- 20a	5- 48a	1-192
2- 22	1- 51	1-212
2- 22a	1- 53a	2-221
1- 23	4- 90a	
*1- 23a	3-111c	

5.13

Food Mixer

Mixer voor voedingsmiddelen

Mixer pour aliments

Frullino

Speisemixer

Hushållsmaskin

Batidora

Misturadora para cozinha

Matblander

7- 2	4- 22	3- 48a	2-126a
2- 3	1- 23	1- 51	*1-186b
8- 5	*1- 23a	1- 52	2-188
4- 10	1- 23a	2- 53a	2-189
2- 11	2- 24	2- 54	1-191
8- 12	2- 27f	4- 90a	2-192
2- 15b	2- 35	2-111	1-199
1- 17	87- 37a	1-111a	1-213
1- 18a	80- 37b	2-111c	2-214
1- 18b	13- 38	1-125	3-215
1- 20a	2- 48	2-126	*1-M5

* Not included in set No. 5

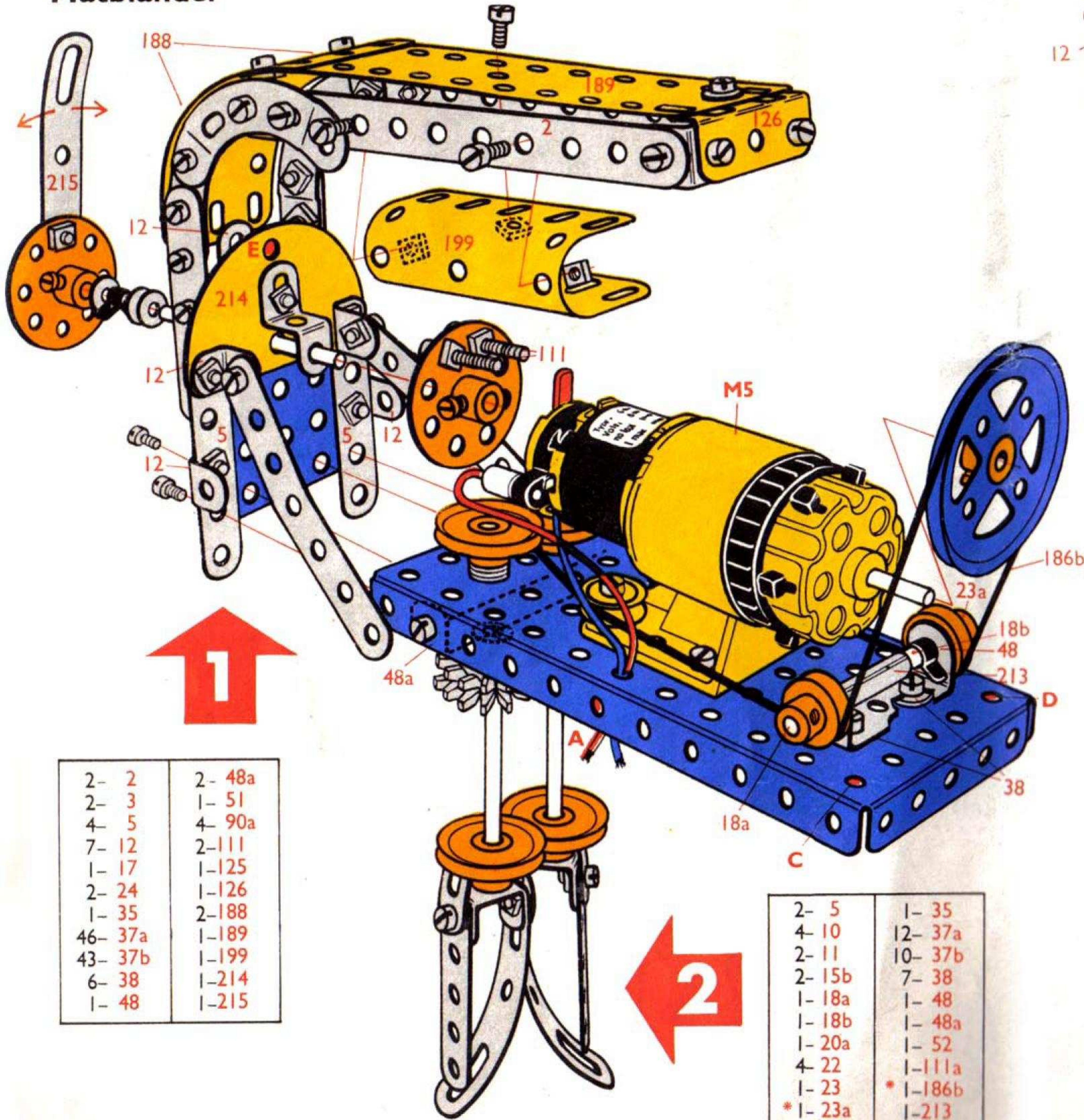

2- 2	2- 48a
2- 3	1- 51
4- 5	4- 90a
7- 12	2-111
1- 17	1-125
2- 24	1-126
1- 35	2-188
46- 37a	1-189
43- 37b	1-199
6- 38	1-214
1- 48	1-215

2- 5	1- 35
4- 10	12- 37a
2- 11	10- 37b
2- 15b	7- 38
1- 18a	1- 48
1- 18b	1- 48a
1- 20a	1- 52
4- 22	1-111a
1- 23	*1-186b
*1- 23a	1-213
1- 23a	2-215
2- 27f	

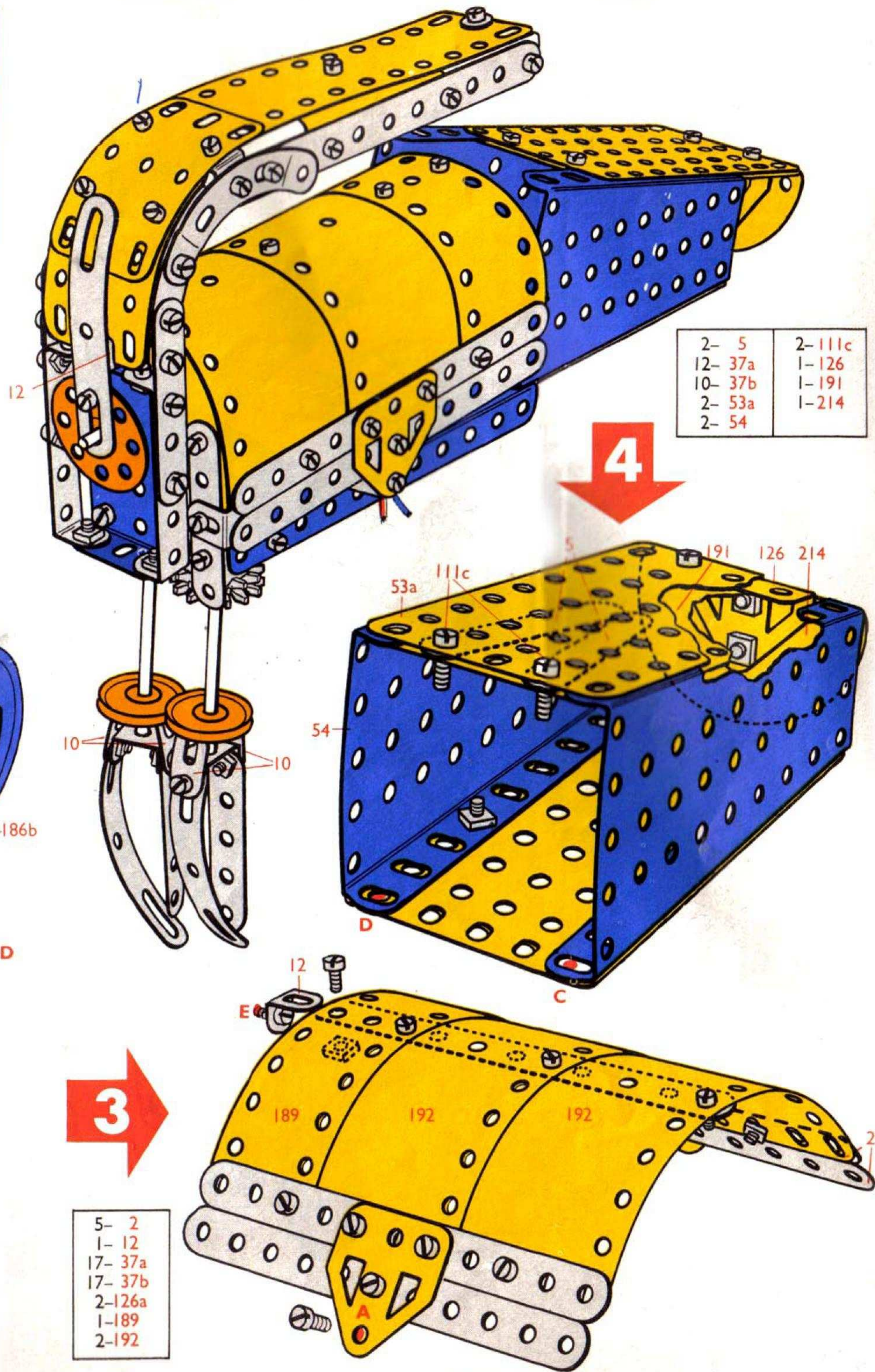

2- 5	2-111c
12- 37a	1-126
10- 37b	1-191
2- 53a	1-214
2- 54	

5- 2
1- 12
17- 37a
17- 37b
2-126a
1-189
2-192

5.14

Scorpion
 Schorpioen
 Scorpione
 Skorpion
 Escorpión
 Escorpião

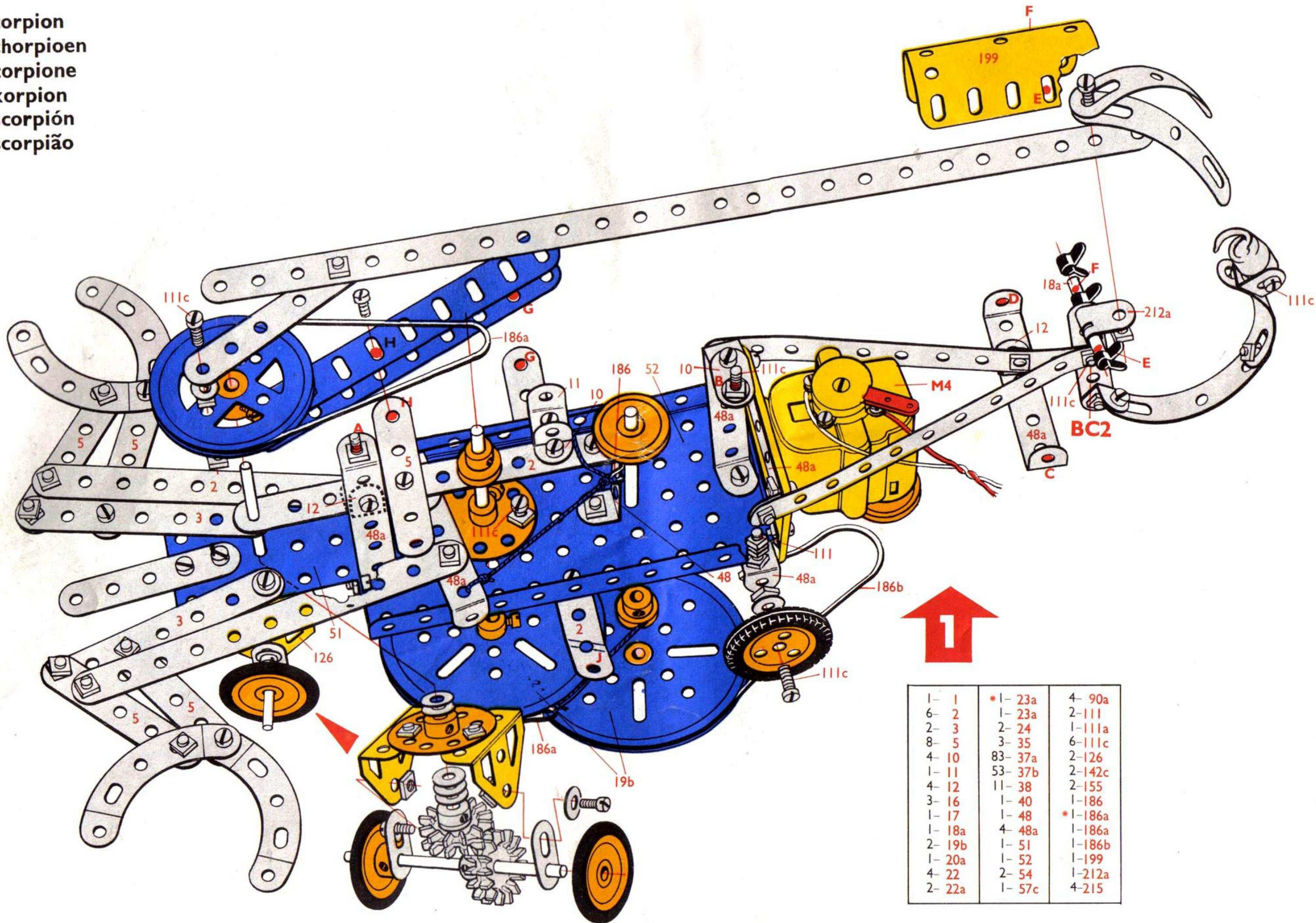

1- 1	*1- 23a	4- 90a
6- 2	1- 23a	2-111
2- 3	2- 24	1-111a
8- 5	3- 35	6-111c
4- 10	83- 37a	2-126
1- 11	53- 37b	2-142c
4- 12	11- 38	2-155
3- 16	1- 40	1-186
1- 17	1- 48	*1-186a
1- 18a	4- 48a	1-186a
2- 19b	1- 51	1-186b
1- 20a	1- 52	1-199
4- 22	2- 54	1-212a
2- 22a	1- 57c	4-215

1- 1	2- 22a	1- 57c	2- 191
8- 2	*1- 23a	4- 90a	2- 192
2- 3	1- 23a	2- 111	1- 193
8- 5	2- 24	1- 111a	2- 194
4- 10	3- 35	6- 111c	1- 199
1- 11	107- 37a	2- 126	1- 200
4- 12	75- 37b	2- 142c	1- 212a
3- 12c	13- 38	2- 155	2- 214
3- 16	1- 40	1- 186	4- 215
1- 17	1- 48	*1- 186a	4- 221
1- 18a	4- 48a	1- 186a	*1- M4
2- 19b	1- 51	1- 186b	
1- 20a	1- 52	1- 189	
4- 22	2- 54	4- 190	

*Not included in set No.5

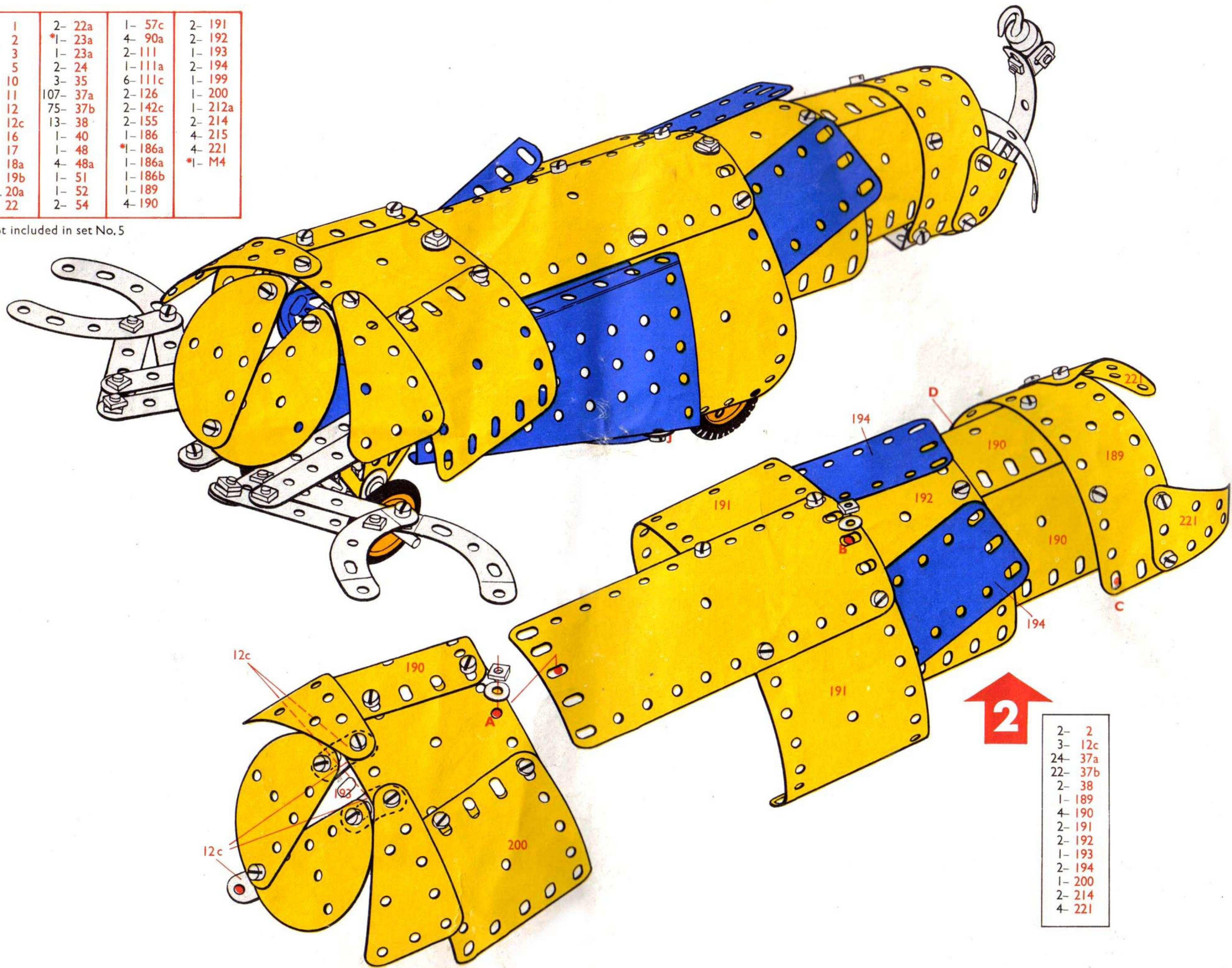

2

2-	2
3-	12c
24-	37a
22-	37b
2-	38
1-	189
4-	190
2-	191
2-	192
1-	193
2-	194
1-	200
2-	214
4-	221

5.15

- Martian**
- Marsbewoner**
- Martien**
- Marziano**
- Marsmensch**
- Marsinnevånare**
- Marciano**
- Marsianer**

4- 1	1- 20a	1- 51	2-189
8- 2	1- 22	1- 52	4-190
2- 3	1- 23a	2- 53a	2-191
9- 5	2- 24	2- 54	2-192
2- 10	2- 35	3- 90a	2-194a
2- 11	105- 37a	2-111	1-200
1- 11a	94- 37b	1-111a	1-212a
10- 12	17- 38	4-111c	2-214
2- 17	2- 38d	2-126	4-215
1- 18a	1- 40	2-126a	4-221
1- 18b	2- 48	2-187	*1-M5
2- 19b	6- 48a	2-188	

4- 2	2- 38d
1- 3	2-111c
2- 12	1-192
2- 17	2-194a
2- 19b	2-214
2- 35	4-215
21- 37a	4-221
19- 37b	

* Not included in set No. 5

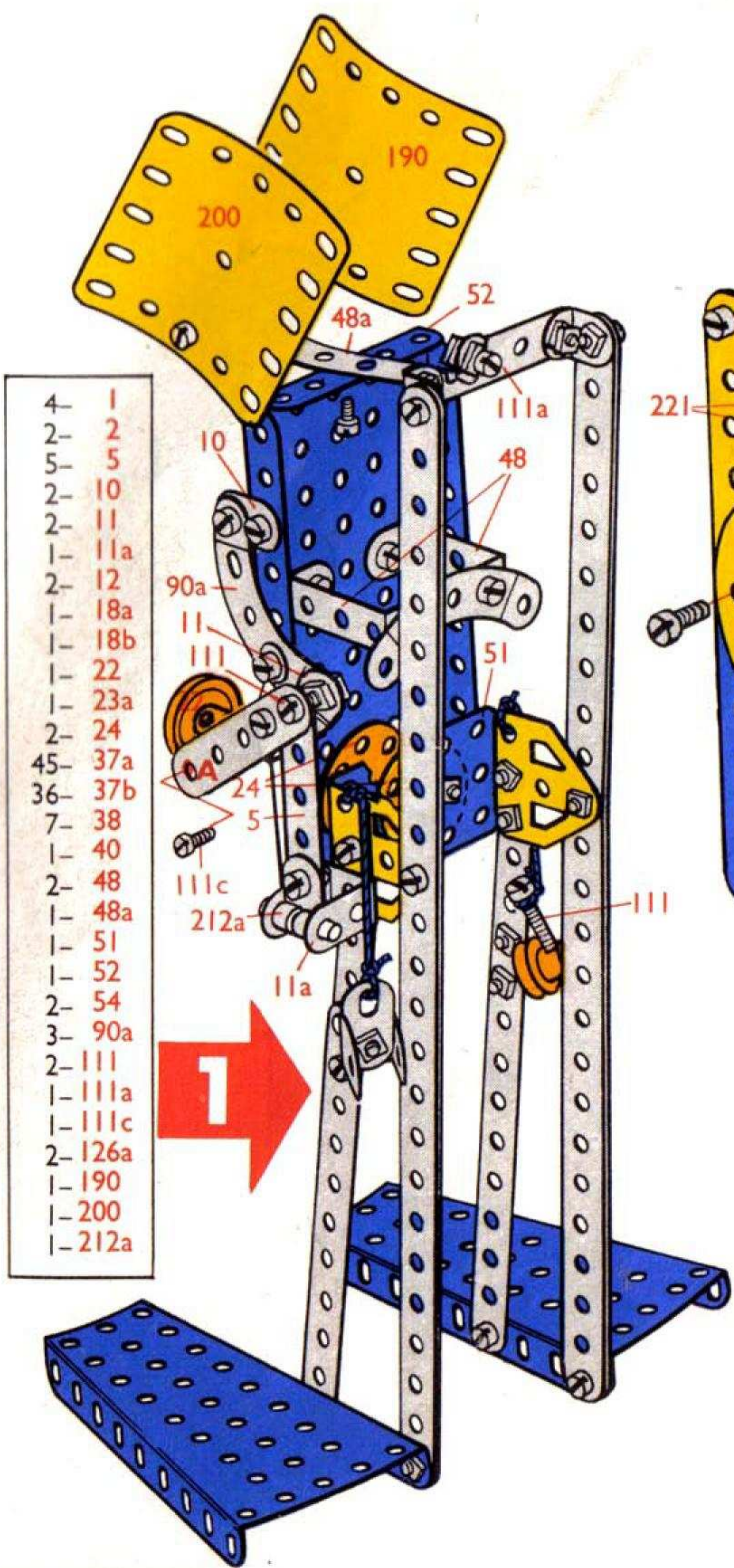

- 4- 1
- 2- 2
- 5- 5
- 2- 10
- 2- 11
- 1- 11a
- 2- 12
- 1- 18a
- 1- 18b
- 1- 22
- 1- 23a
- 2- 24
- 45- 37a
- 36- 37b
- 7- 38
- 1- 40
- 2- 48
- 1- 48a
- 1- 51
- 1- 52
- 2- 54
- 3- 90a
- 2- 111
- 1- 111a
- 1- 111c
- 2- 126a
- 1- 190
- 1- 200
- 1- 212a

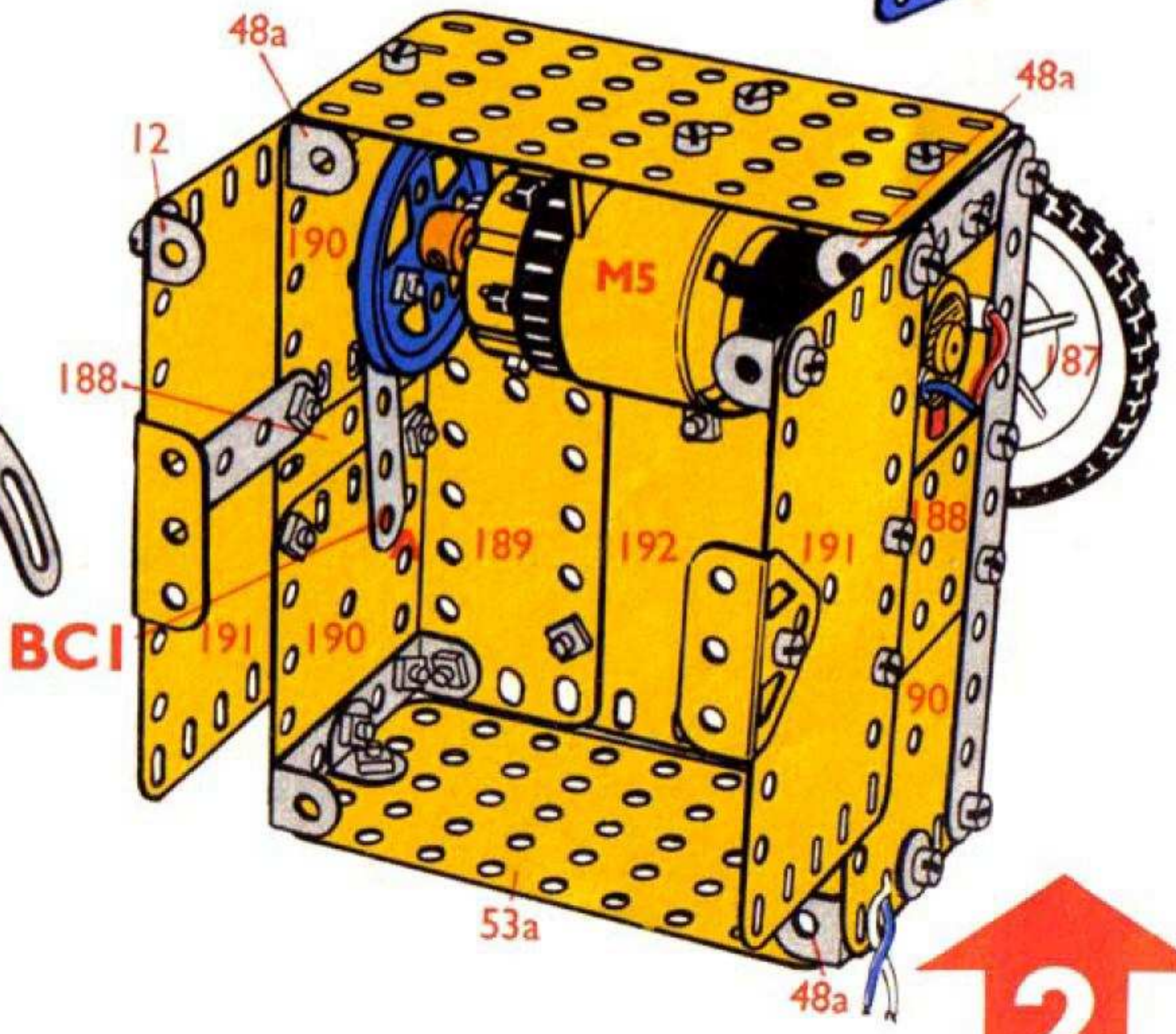
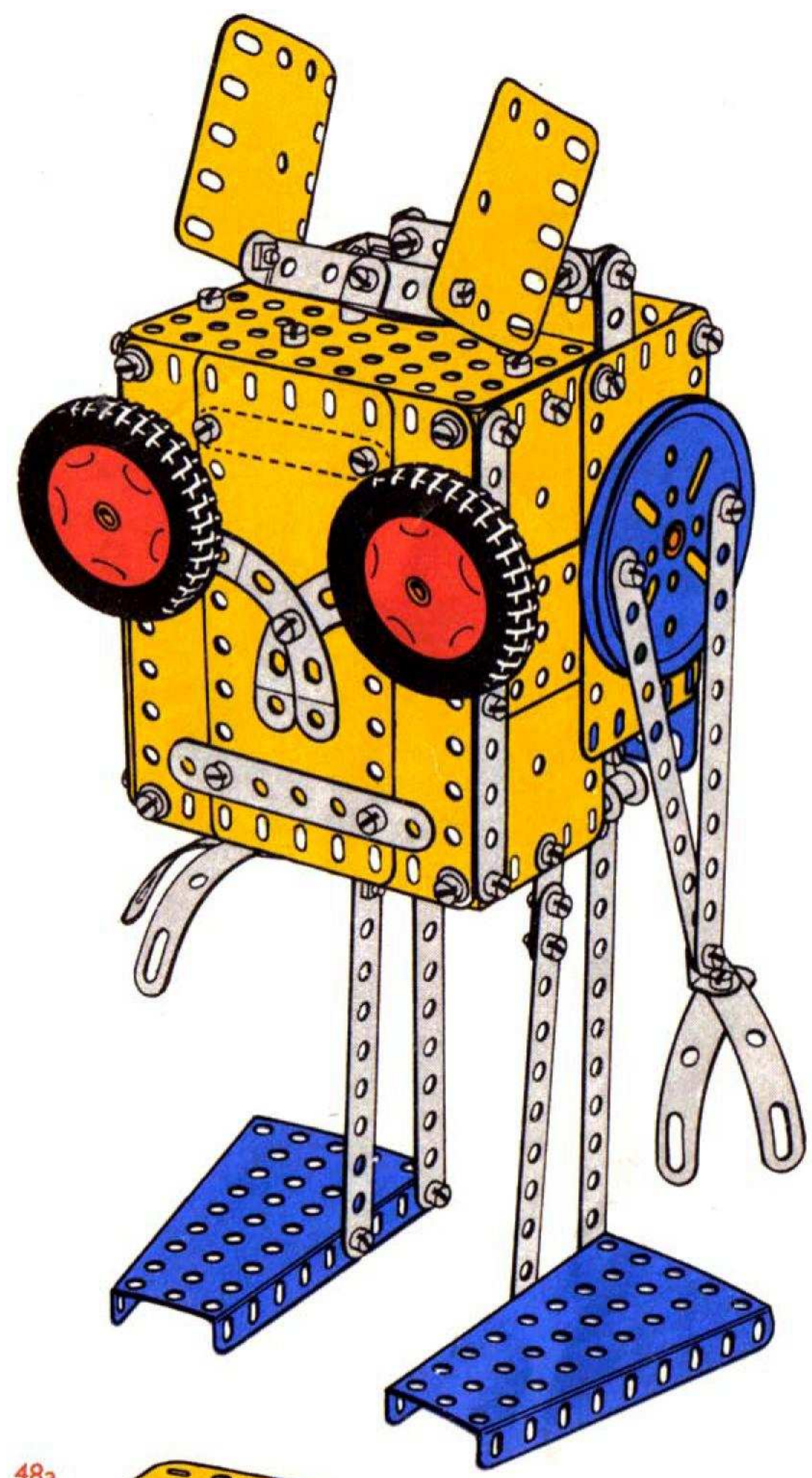
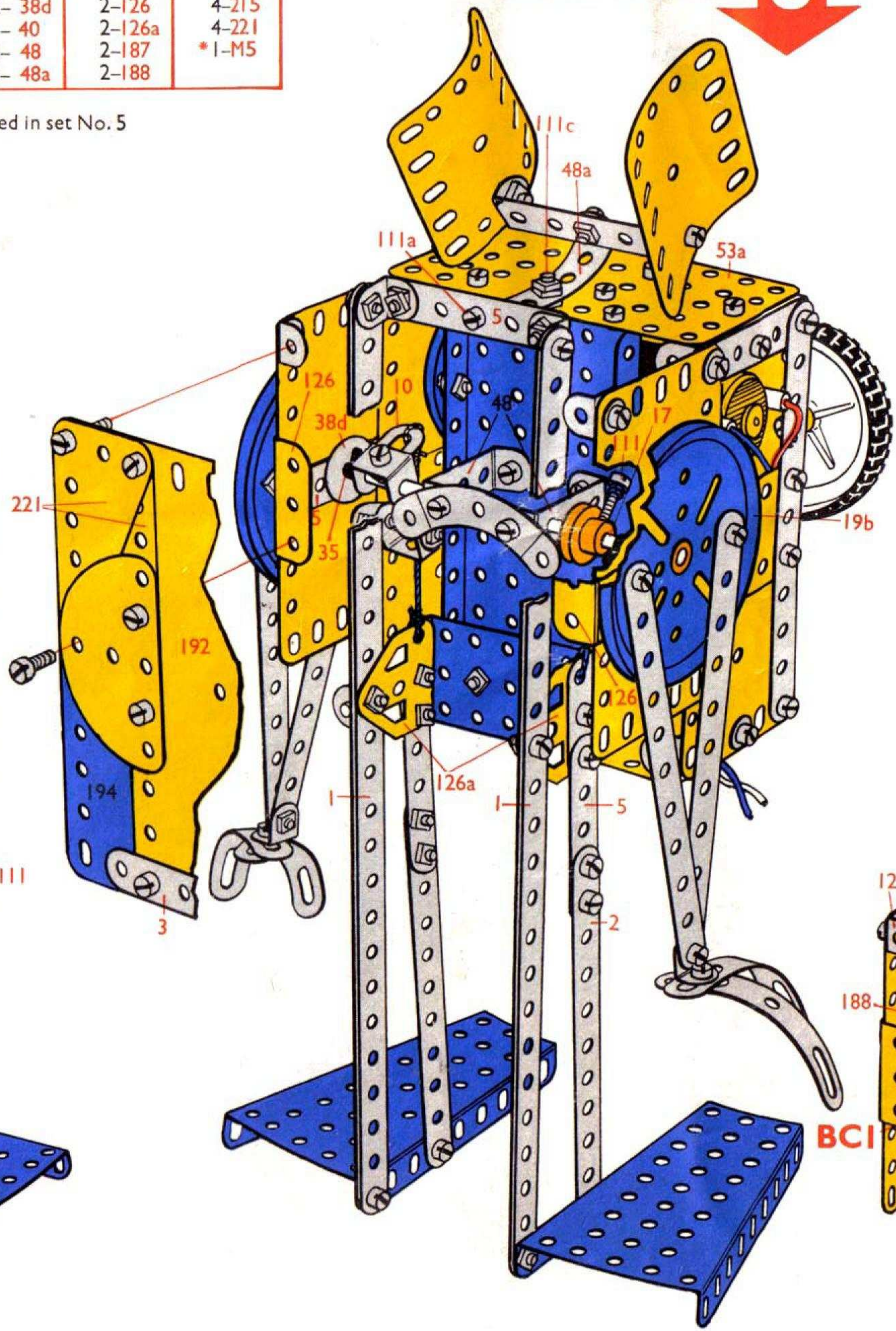

- 2- 2
- 1- 3
- 4- 5
- 6- 12
- 1- 20a
- 39- 37a
- 39- 37b
- 10- 38
- 4- 48a
- 2- 53a
- 1-111c
- 2-126
- 2-187
- 2-188
- 2-189
- 3-190
- 2-191
- 1-192

ELECTRONIC 5.16.

Automatic Press
 Automatische pers
 Presse automatique
 Pressa automatica
 Automatische Presse
 Automatisk press
 Prensa automatica
 Prensa Automatica
 Automatpresse

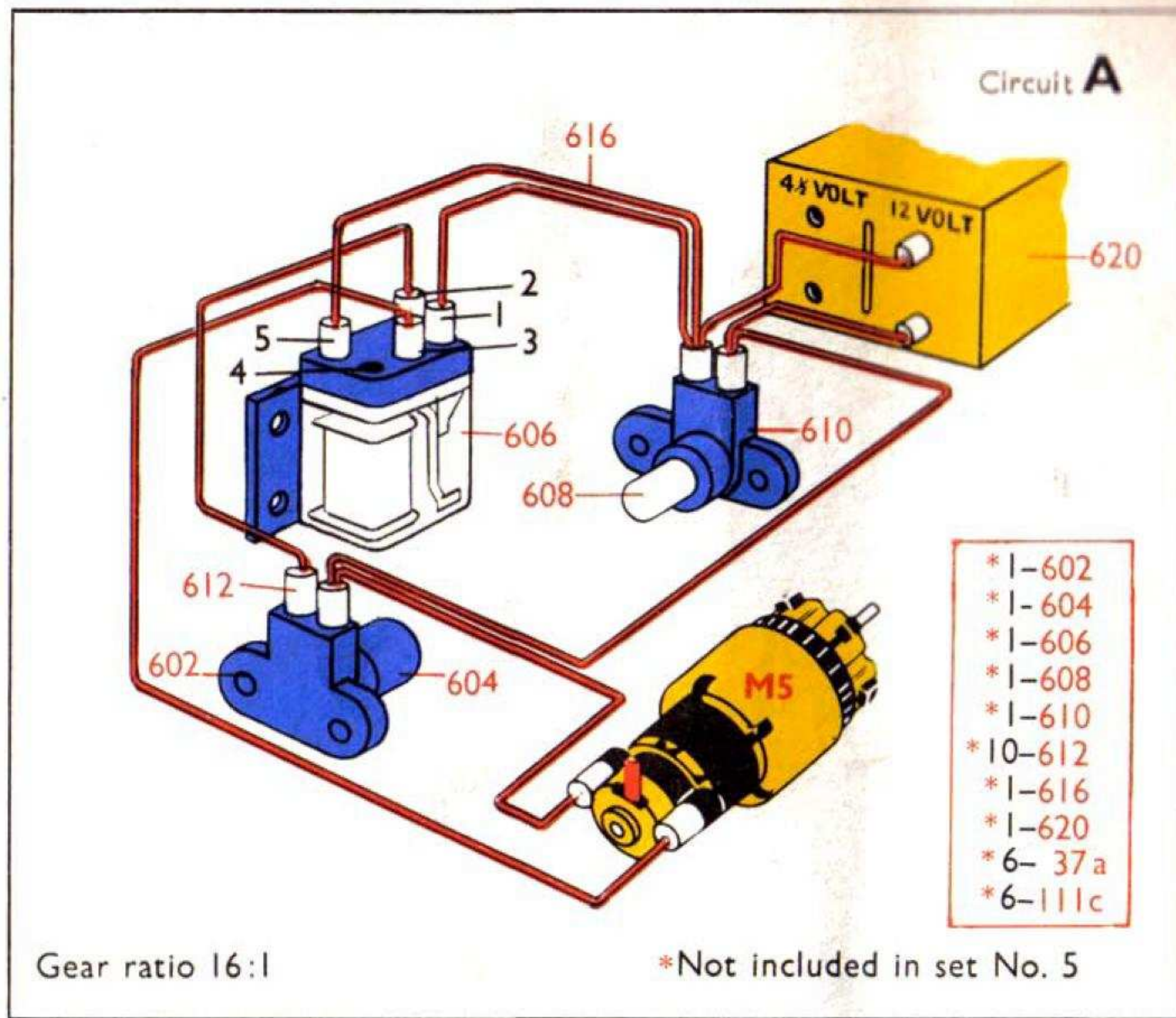

8- 2	1- 23a	1-111a
1- 3	2- 24	5-111c
5- 5	2- 27f	2-126
2-10	7- 35	2-126a
2-15b	52-37a	1-186a
1- 16	44-37b	*1-186b
2-17	16-38	1-191
2-18a	2- 40	1-212
1-18b	6- 48a	1-213
1-19b	1- 51	2-214
1-20a	1- 52	*1-M5
4- 22	2- 53a	
*1-23a	2- 54	

*Not included in set No. 5

2- 2	2- 35
1- 3	16-37a
2- 5	14-37b
2-15b	8- 38
1-20a	1- 52
2- 22	2- 54
1-23a	2-111c
*1-23a	2-126
2- 27f	1-186a

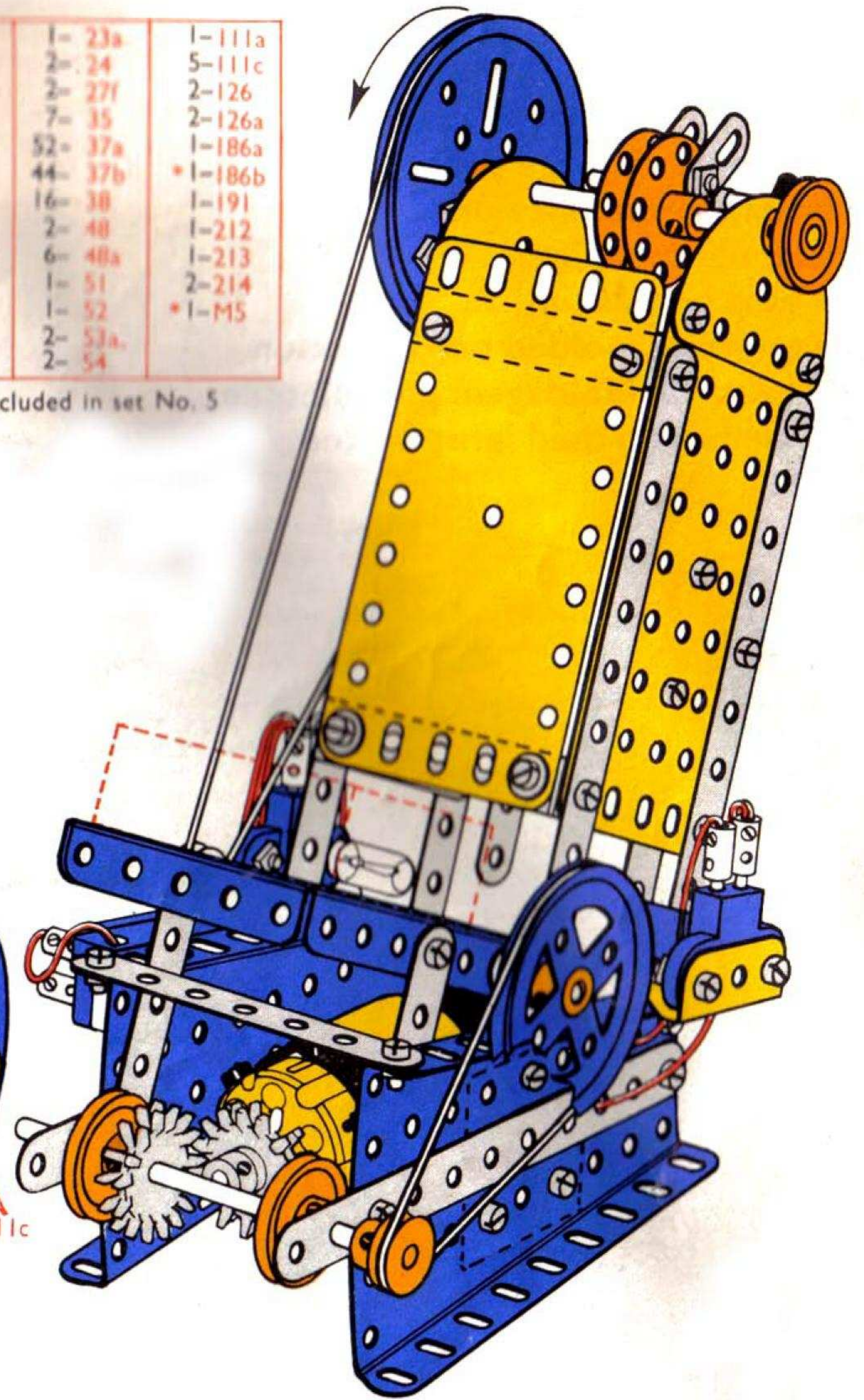
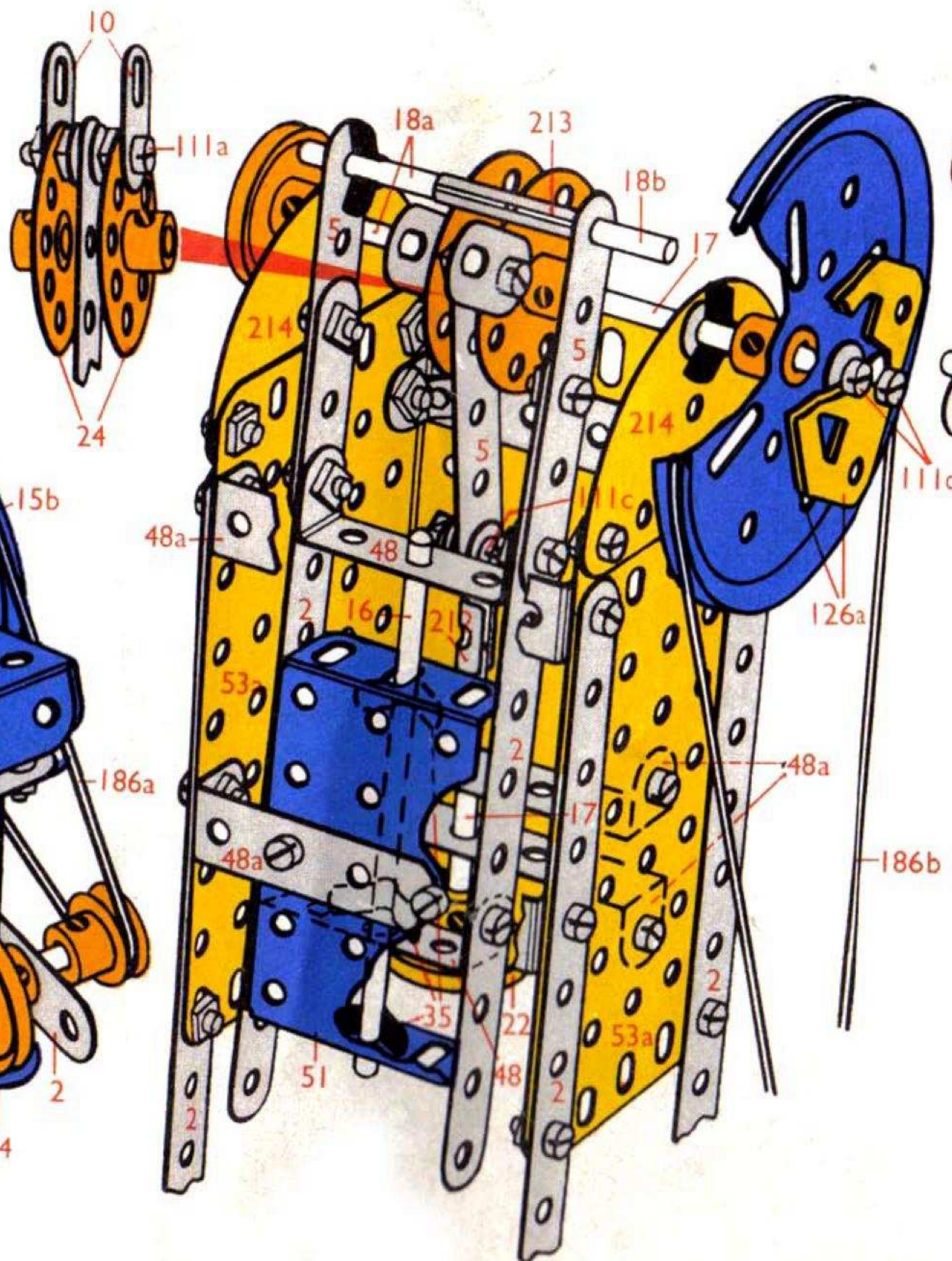
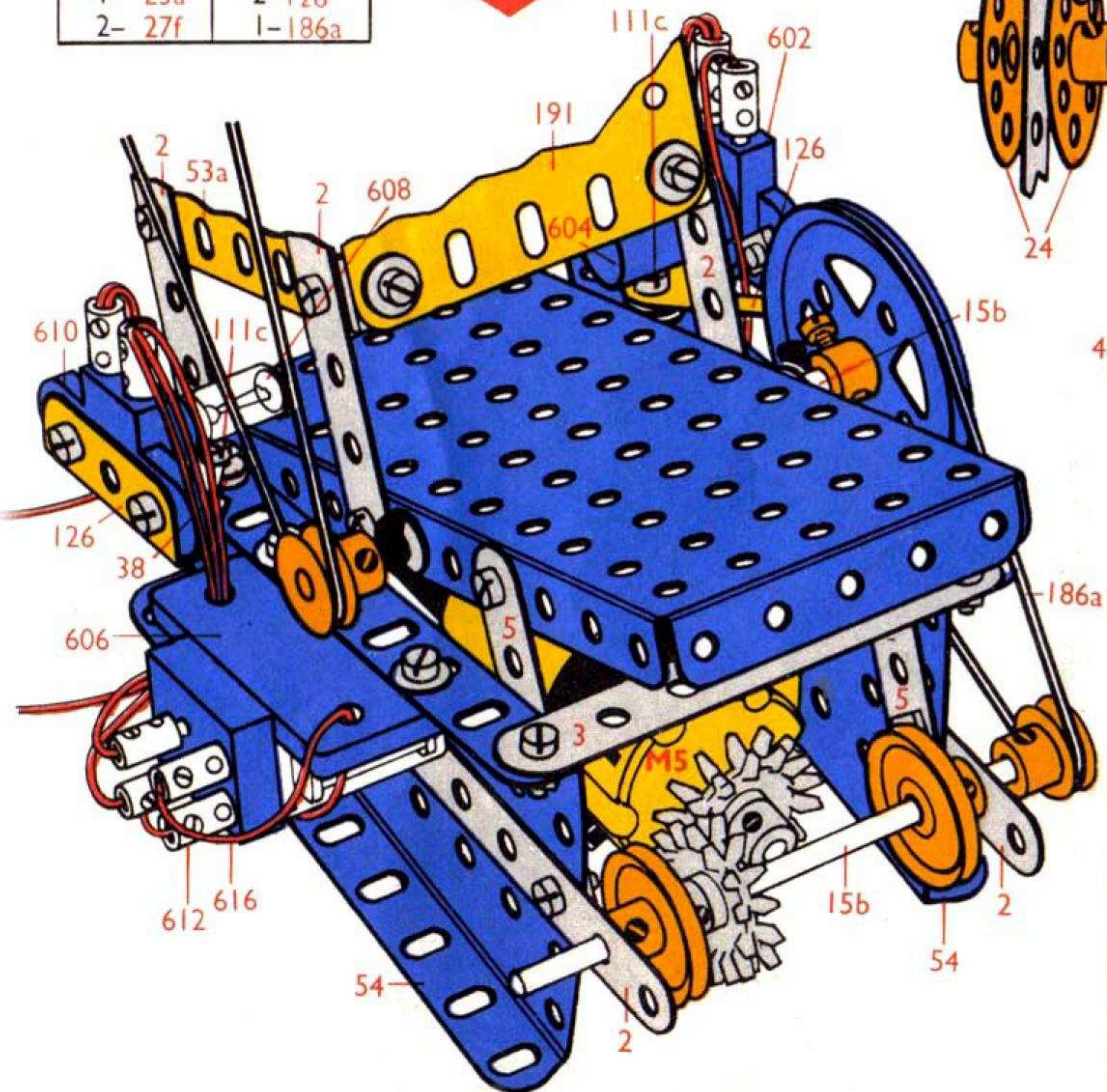
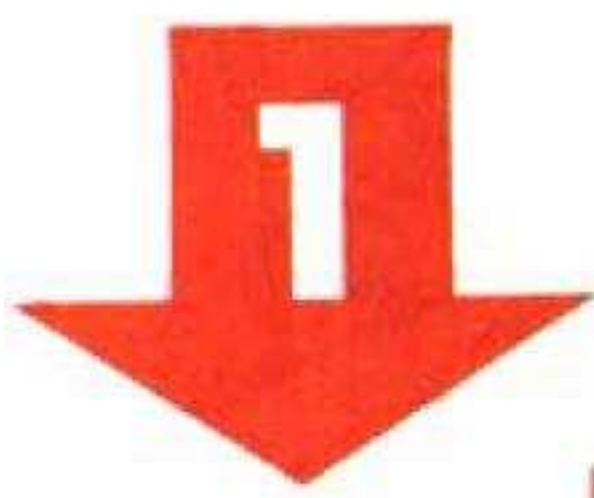

6- 2	2- 24	1-111a
3- 5	5- 35	3-111c
2-10	29-37a	2-126a
1- 16	22-37b	1-186b
1- 17	8- 38	1-191
2-18a	2- 48	1-212
1-18b	6- 48a	1-213
1-19b	1- 51	2-214
2- 22	2- 53a	

ELECTRONIC 5.17.

Injection Moulding Machine

Sputgietmachine

Machine à moulage par injection

Formatrice ad iniezione

Spritgussmaschine

Formsprutmaskin

Máquina de moldeo por inyección

Máquina de Moldagem por Injecção

Formemaskin med innsprøyting

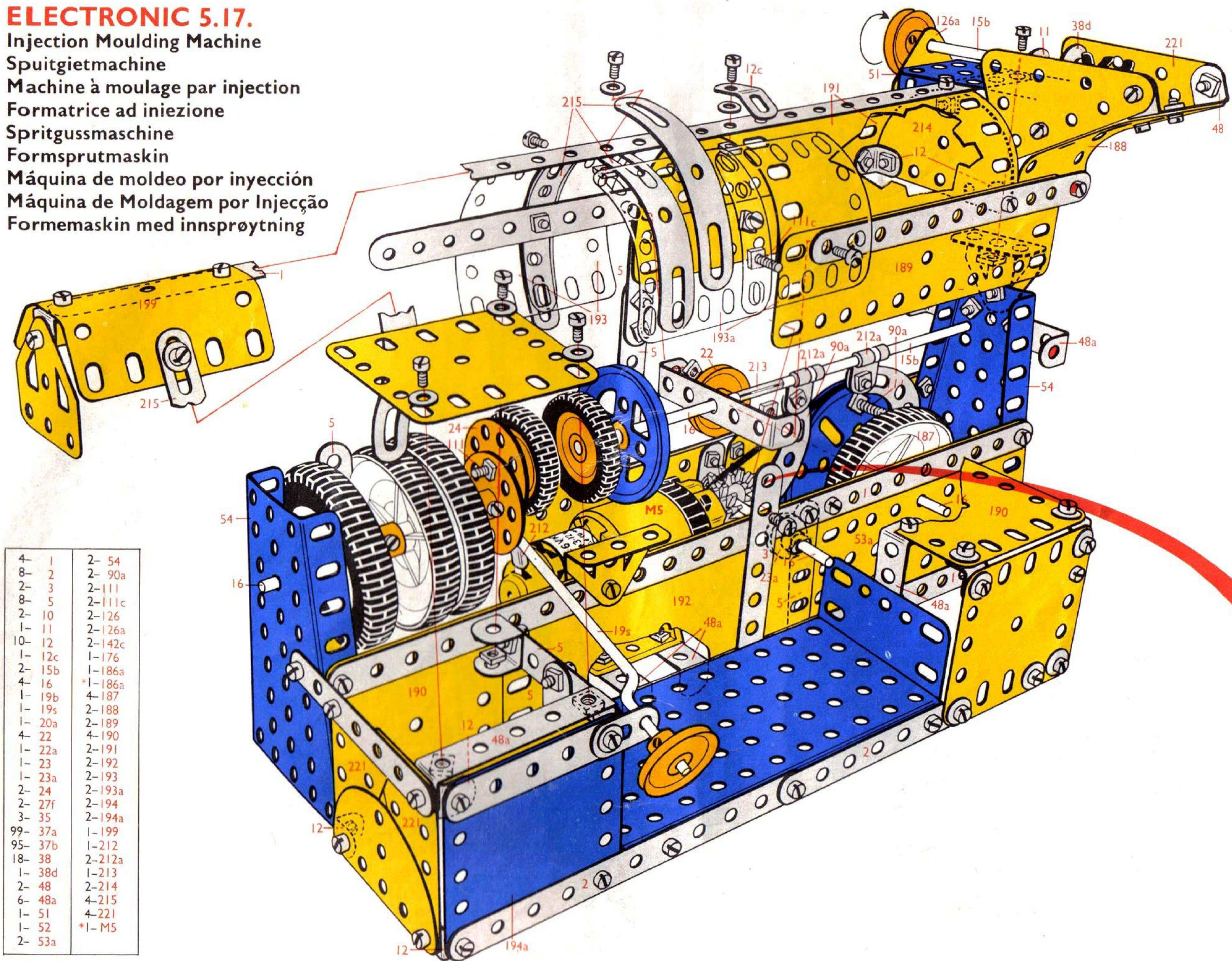

4-	1	2-	54
8-	2	2-	90a
2-	3	2-	111
8-	5	2-	111c
2-	10	2-	126
1-	11	2-	126a
10-	12	2-	142c
1-	12c	1-	176
2-	15b	1-	186a
4-	16	*1-	186a
1-	19b	4-	187
1-	19s	2-	188
1-	20a	2-	189
4-	22	4-	190
1-	22a	2-	191
1-	23	2-	192
1-	23a	2-	193
2-	24	2-	193a
2-	27f	2-	194
3-	35	2-	194a
99-	37a	1-	199
95-	37b	1-	212
18-	38	2-	212a
1-	38d	1-	213
2-	48	2-	214
6-	48a	4-	215
1-	51	4-	221
1-	52	*1-	M5
2-	53a		

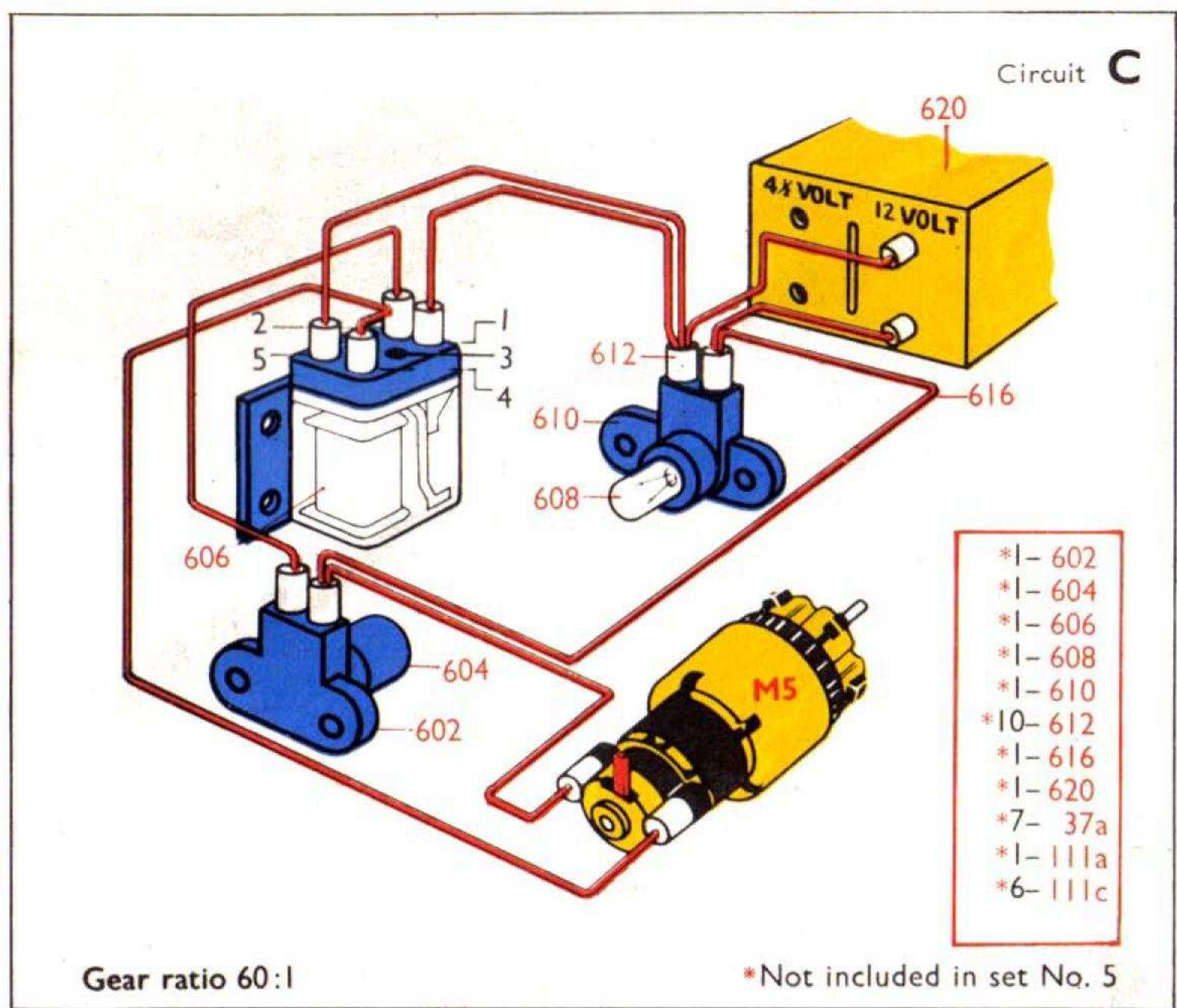

4- 1	1- 23	2- 90a	2- 193
8- 2	1- 23a	2- 111	2- 193a
2- 3	2- 24	2- 111c	2- 194
8- 5	2- 27f	2- 126	2- 194a
2- 10	3- 35	2- 126a	1- 199
1- 11	99- 37a	2- 142c	1- 212
10- 12	95- 37b	1- 176	2- 212a
1- 12c	18- 38	1- 186a	1- 213
2- 15b	1- 38d	*1- 186a	2- 214
4- 16	2- 48	4- 187	4- 215
1- 19b	6- 48a	2- 188	4- 221
1- 19s	1- 51	2- 189	*1- M5
1- 20a	1- 52	4- 190	
4- 22	2- 53a	2- 191	
1- 22a	2- 54	2- 192	

*Not included in set No. 5

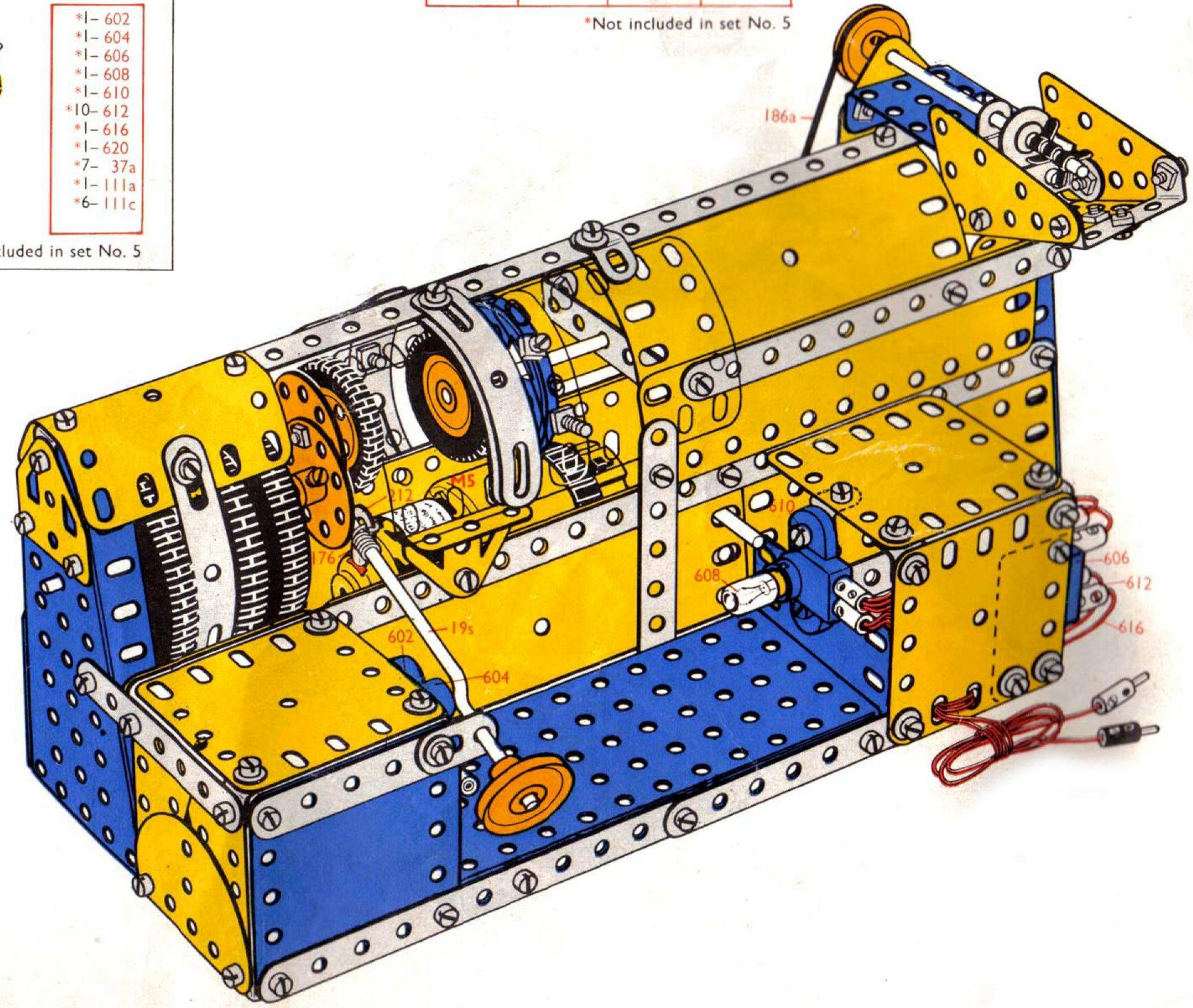
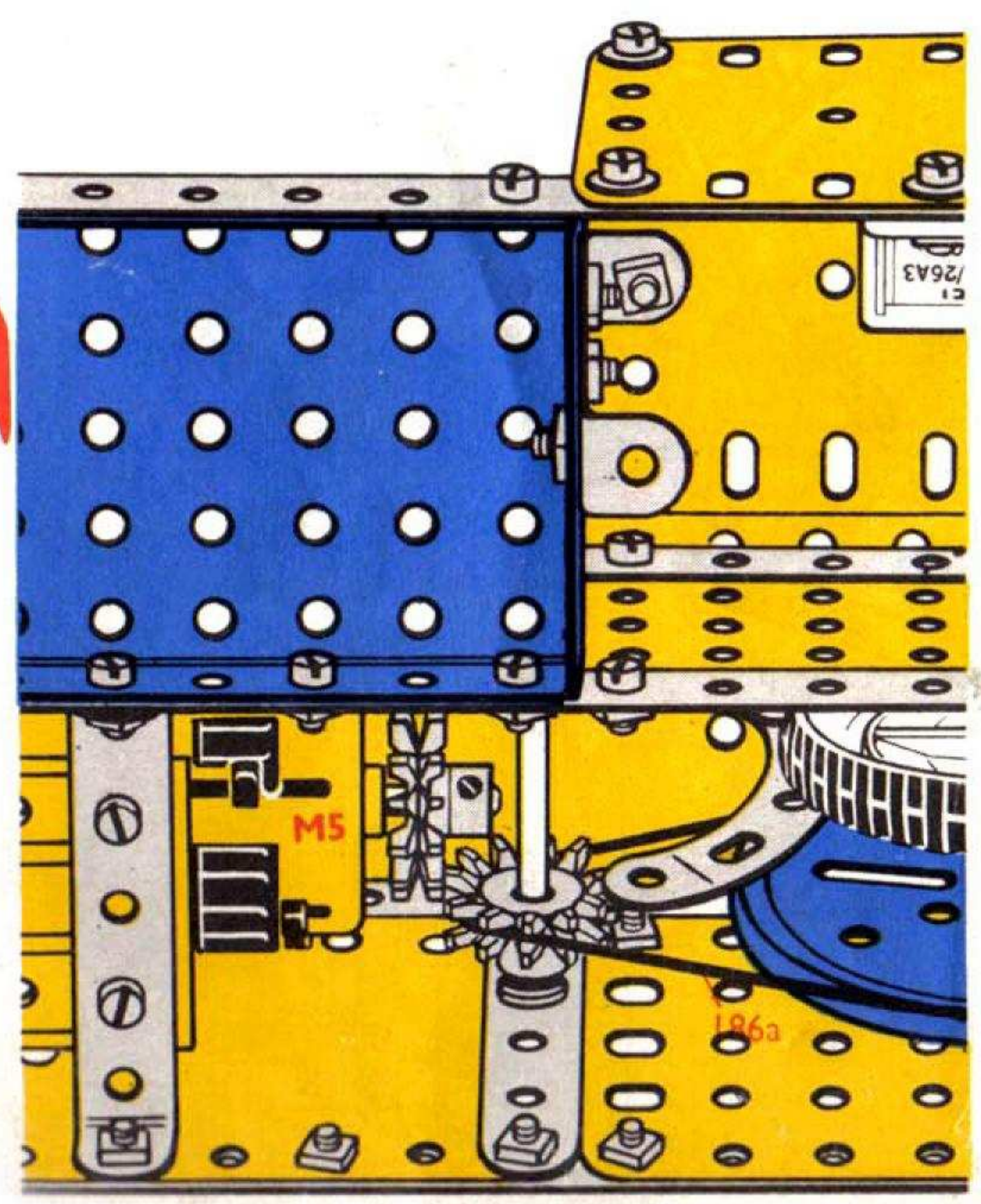

ELECTRONIC 5.18.

- Counting Conveyor
- Teltransporteur
- Convoyeur-compteur
- Trasportatore contatore
- Zahlforderer
- Transportor med rakneverk
- Transportador contador
- Transportador Contador
- Telletransportor

4- 1	1- 23a	2- 111a
5- 2	2- 24	2- 111c
2- 3	2- 27f	2- 126
9- 5	14- 35	2- 126a
4- 10	87- 37a	1- 155
2- 11	71- 37b	1- 186
1- 11a	18- 38	1- 186a
8- 12	2- 38d	*1- 186a
2- 15b	1- 40	2- 190
4- 16	1- 48	2- 192
1- 17	6- 48a	1- 212
2- 19b	1- 51	2- 212a
1- 20a	1- 52	1- 213
4- 22	2- 53a	2- 214
2- 22a	2- 54	*1- M5
1- 23	4- 90a	
*1- 23a	1- 111	

*Not included in set No. 5

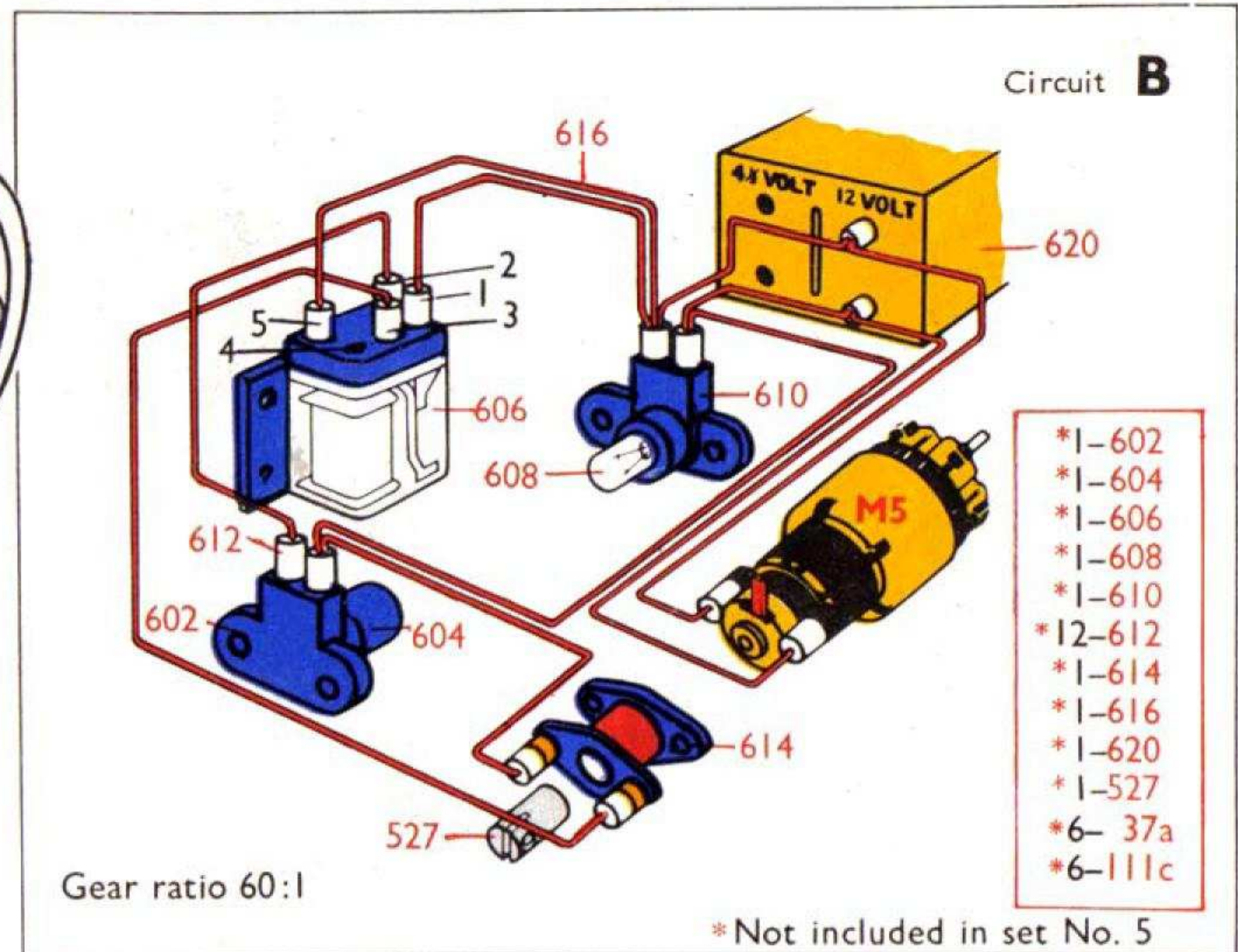
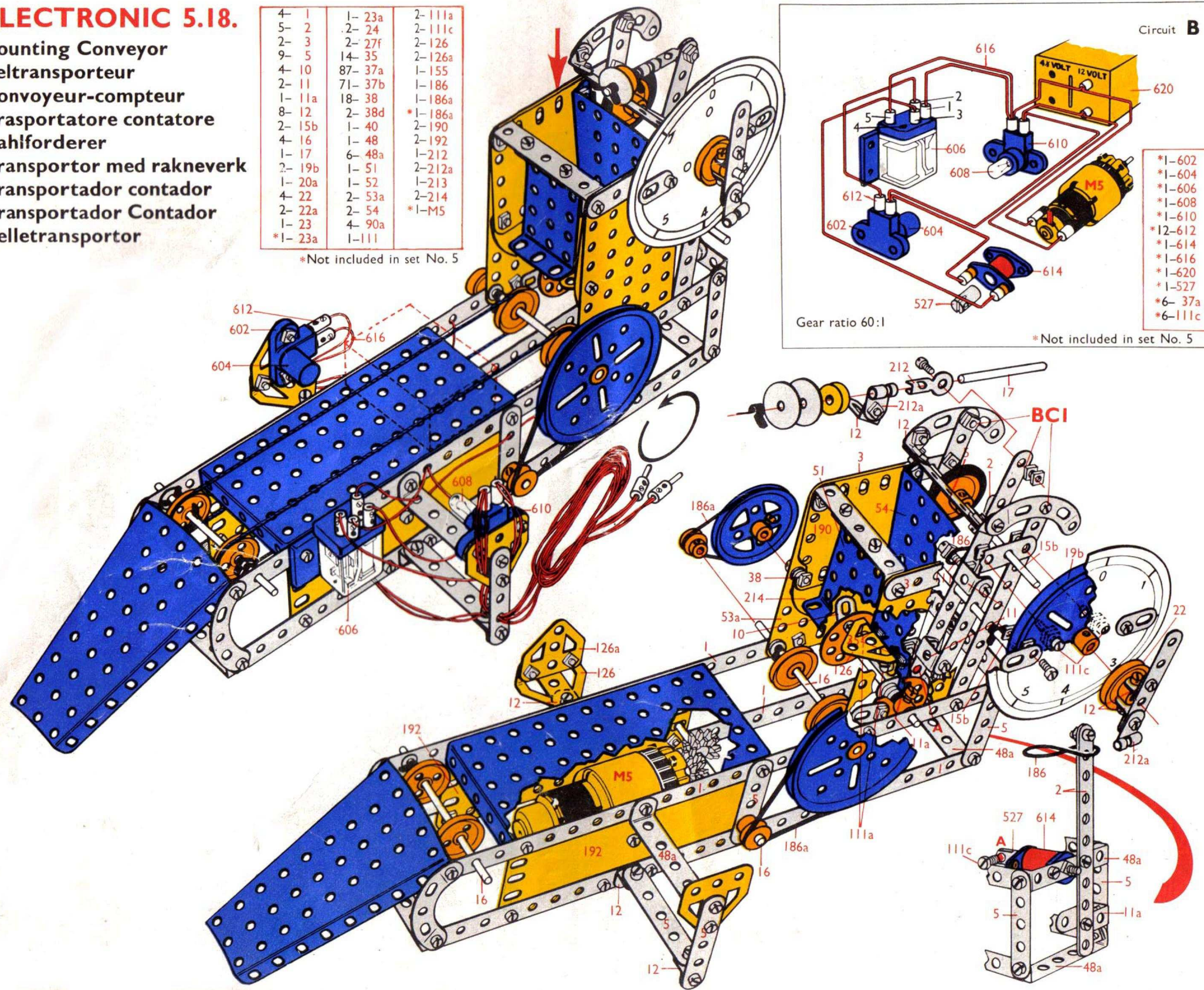

Circuit B

Gear ratio 60:1

*Not included in set No. 5

- *1- 602
- *1- 604
- *1- 606
- *1- 608
- *1- 610
- *12- 612
- *1- 614
- *1- 616
- *1- 620
- *1- 527
- *6- 37a
- *6- 111c

BCI

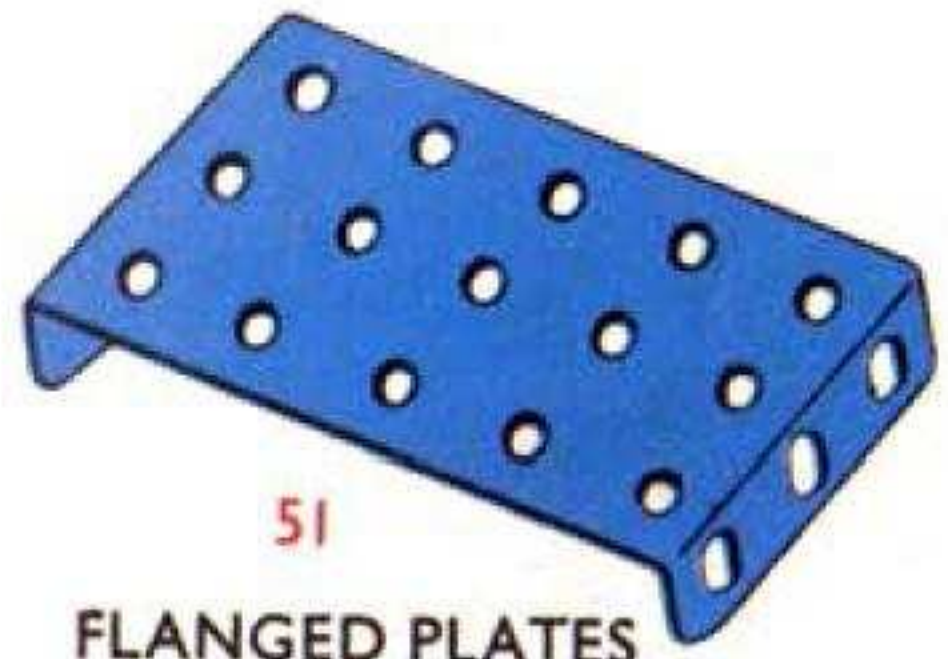

51
FLANGED PLATES
51 - 2½" × 1½"; 60 × 38 mm
52 - 5½" × 2½"; 14 × 6 cm
53 - 3½" × 2½"; 9 × 6 cm

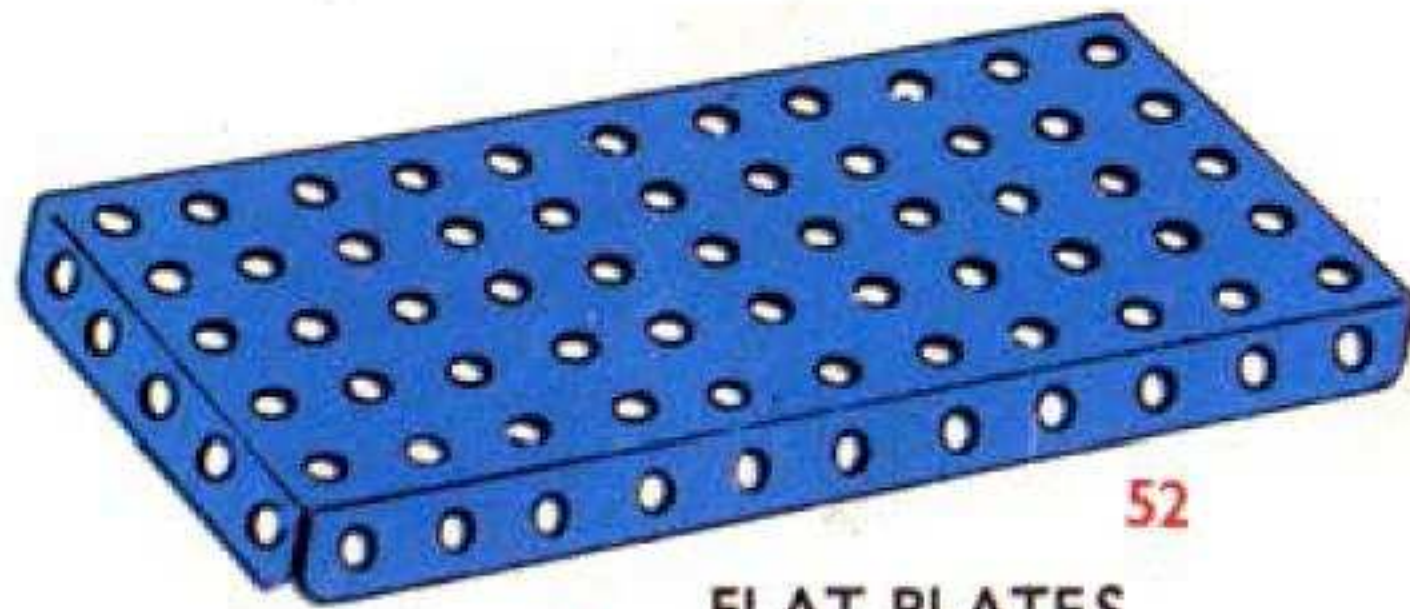

52
FLAT PLATES
52a - 5½" × 3½"; 14 × 9 cm
53a - 4½" × 2½"; 11½ × 6 cm

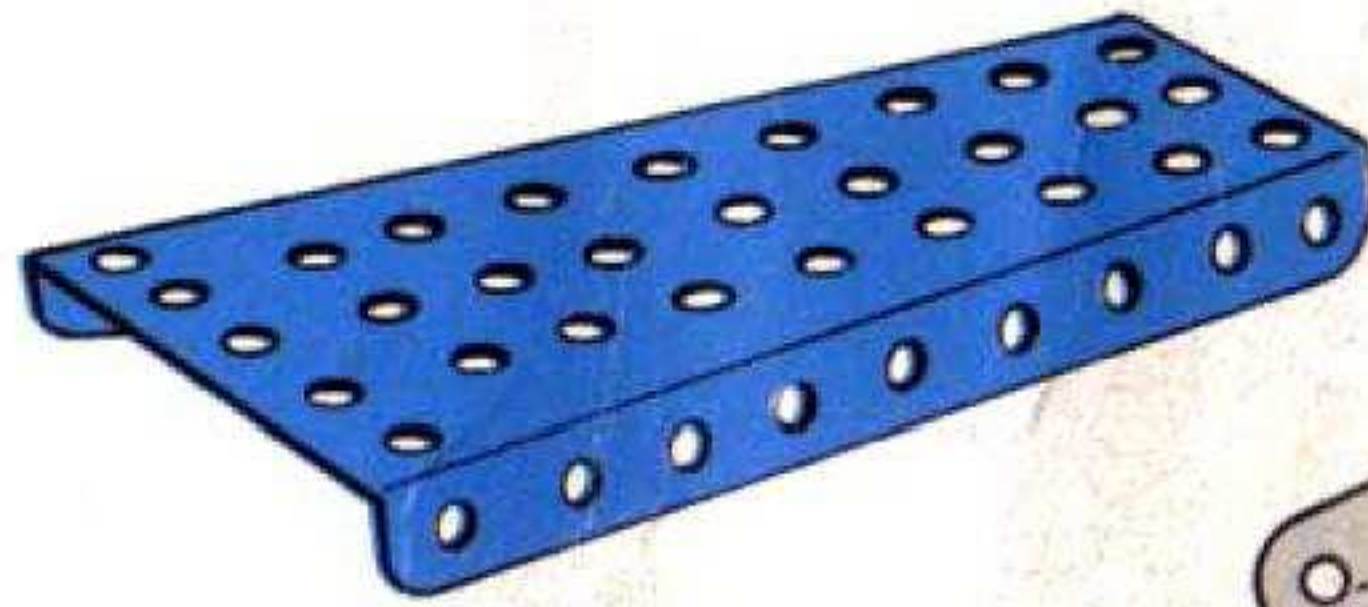

54 - 4½"; 115 mm
FLANGED SECTOR PLATE



PERFORATED SLOTTED STRIP
55 - 5½"; 14 cm
55a - 2"; 5 cm



57b
HOOK



57c
HOOK



57d
WIRE HOOK



58 **SPRING CORD** - 40"; 1 metre



58a
COUPLING SCREW FOR 58



58b
HOOK FOR 58



59
COLLAR WITH SCREW



61
WINDMILL SAIL



62
62 **CRANK**
62a **THREADED CRANK**



62b **DOUBLE ARM CRANK**



63
COUPLING



63b **STRIP COUPLING**



63c
THREADED COUPLING



63d **SHORT COUPLING**



64
THREADED BOSS



65
CENTRE FORK



69 - ¼"; 4 mm
SET SCREW



69a - ½"; 4 mm
69b - ⅜"; 5 mm
69c - ¼"; 3 mm
GRUB SCREWS



70 - 5½" × 2½"; 14 × 6 cm
72 - 2½" × 2½"; 6 × 6 cm
73 - 3" × 1½"; 75 × 38 mm
74 - 1½" × 1½"; 38 × 38 mm
FLAT PLATES

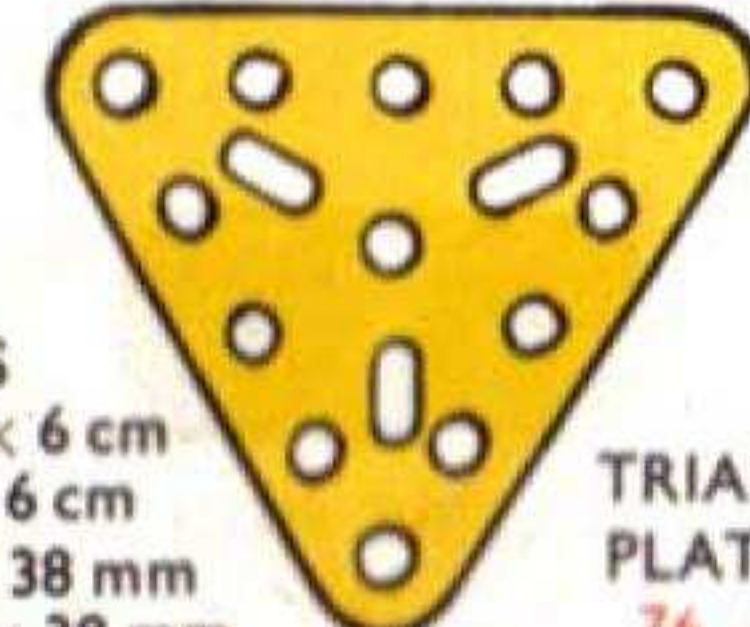

76 - 2½"; 6 cm
77 - 1"; 25 mm
TRIANGULAR PLATES



78 - 11½"; 29 cm
79 - 8"; 20 cm
79a - 6"; 15 cm
80 - 5"; 12½ cm
80a - 3½"; 9 cm
80b - 4½"; 11½ cm
80c - 3"; 7½ cm
81 - 2"; 5 cm
82 - 1"; 25 mm
SCREWED RODS

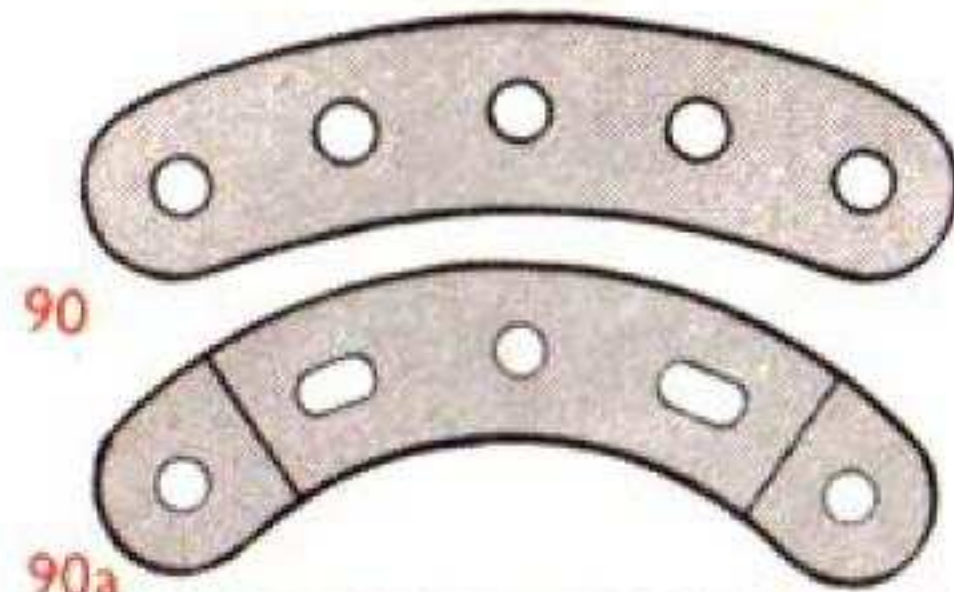

89 - 5½"; 14 cm
90 - 2½"; 6 cm
89a - 3"; 7½ cm
89b - 4"; 10 cm
90a - 2½"; 6 cm
CURVED STRIP

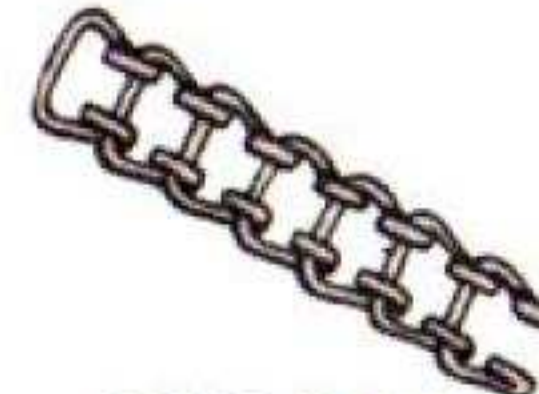

94 - 40"; 1 metre
SPROCKET CHAIN



95 - 2"; 5 cm
95a - 1½"; 38 mm
95b - 3"; 75 mm
96 - 1"; 25 mm
96a - ¾"; 19 mm
SPROCKET WHEELS

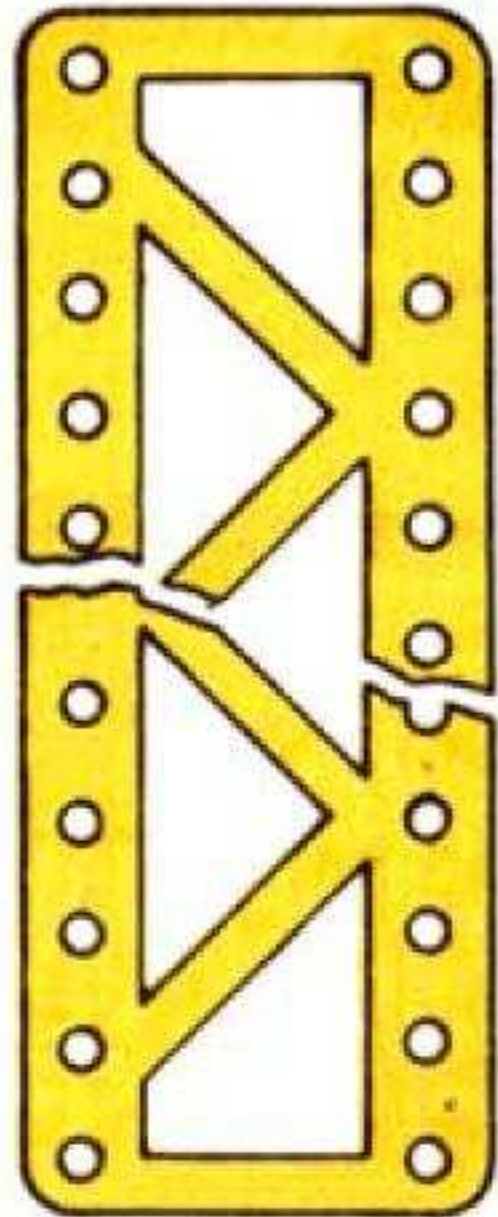

97 - 3½"; 9 cm
99 - 12½"; 32 cm
99a - 9½"; 24 cm
99b - 7½"; 19 cm
100 - 5½"; 14 cm
BRACED GIRDEERS



101
HEALD FOR LOOM

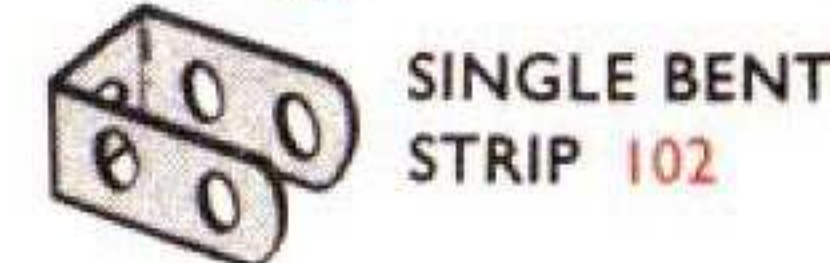

102
SINGLE BENT STRIP

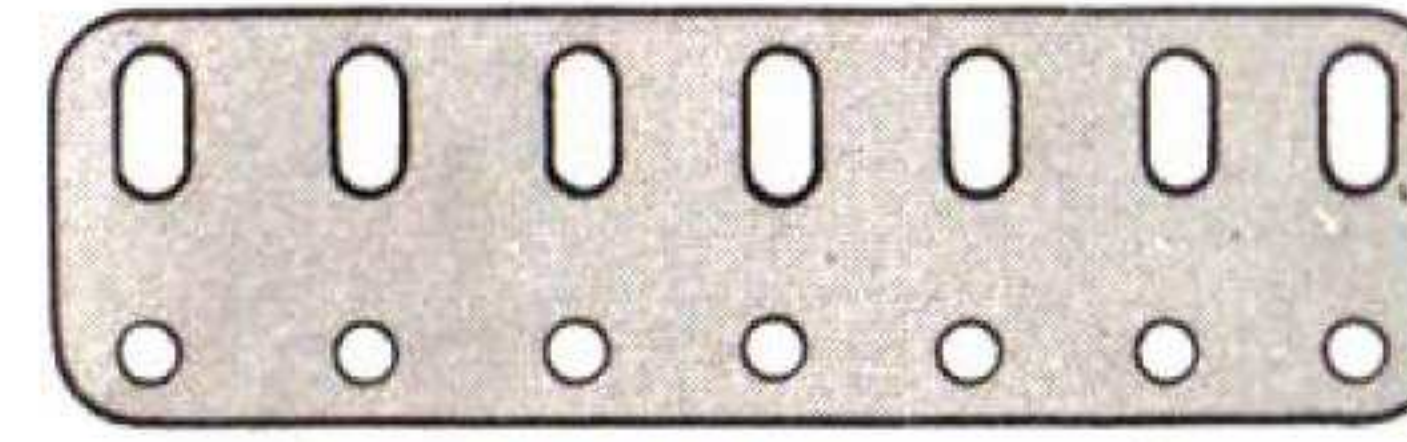

103 - 5½"; 14 cm
103a - 9½"; 24 cm
103b - 12½"; 32 cm
103c - 4½"; 11½ cm
103d - 3½"; 9 cm
103e - 3"; 7½ cm
103f - 2½"; 6 cm
103g - 2"; 5 cm
103h - 1½"; 38 mm
103k - 7½"; 19 cm
FLAT GIRDEERS



106
WOOD ROLLER

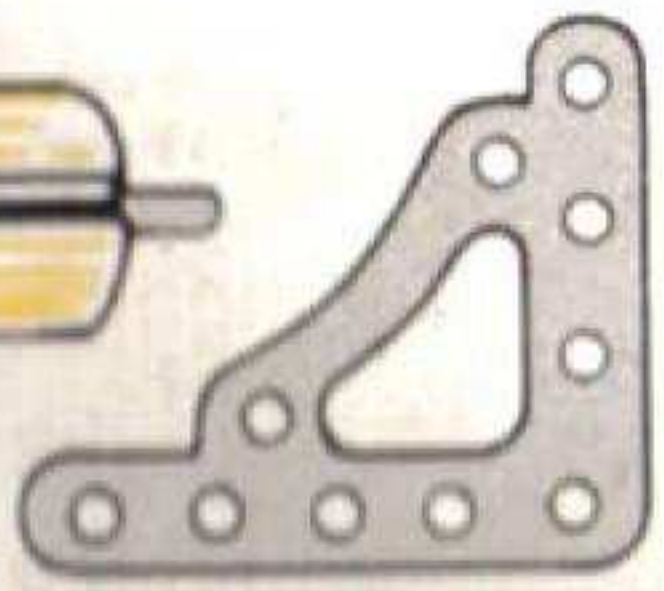

108
CORNER GUSSET

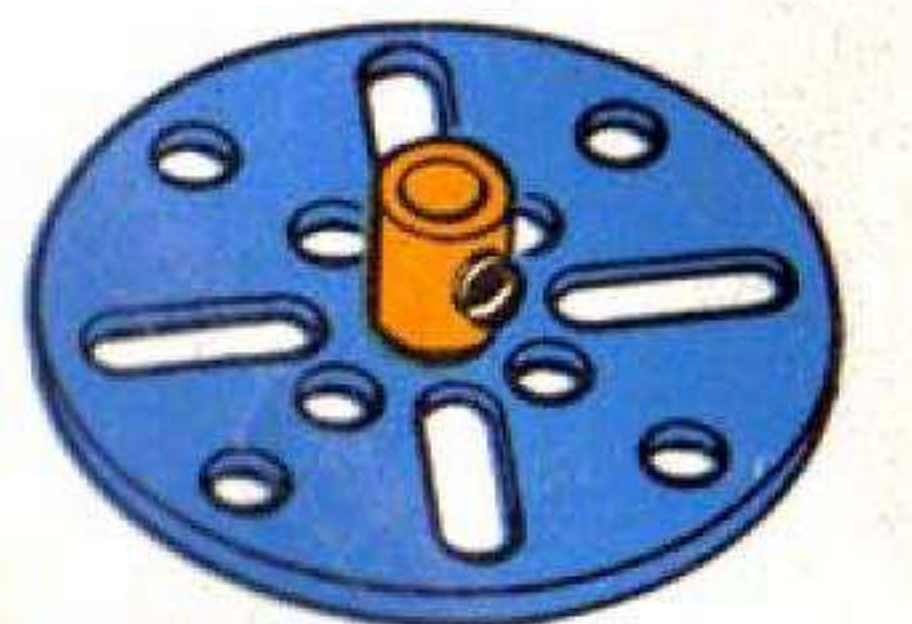

109 - 2½"; 6 cm
FACE PLATE



110 - 3½"; 9 cm
110a - 6½"; 16½ cm
RACK STRIPS



111 - ¾"; 19 mm
111a - ½"; 12 mm
111c - ¾"; 9½ mm
111d - 1½"; 28½ mm
BOLTS

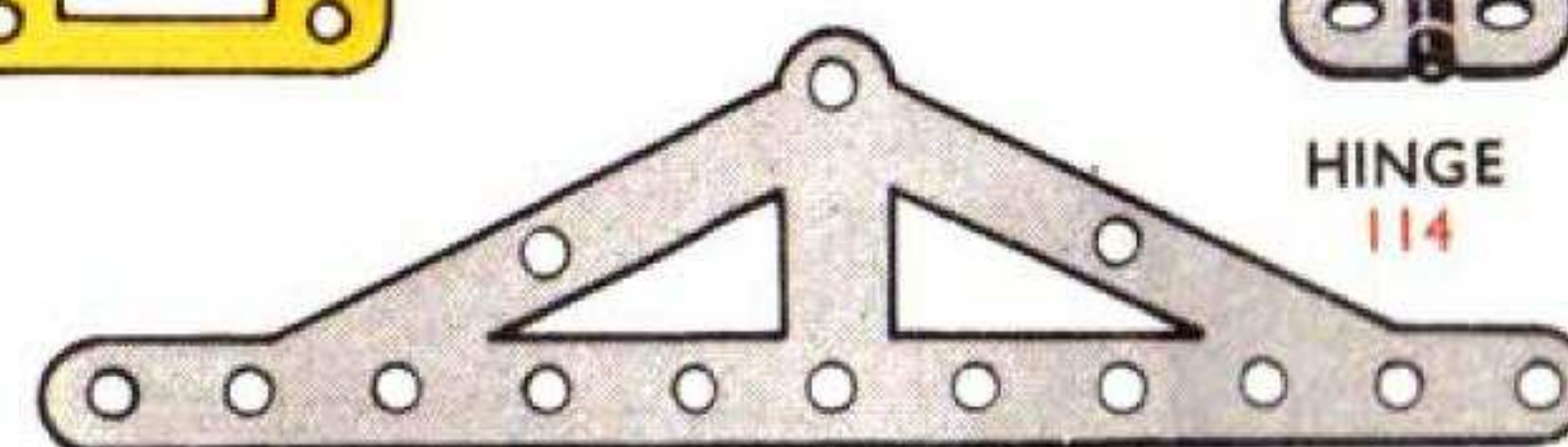

113
GIRDER FRAME



114
HINGE

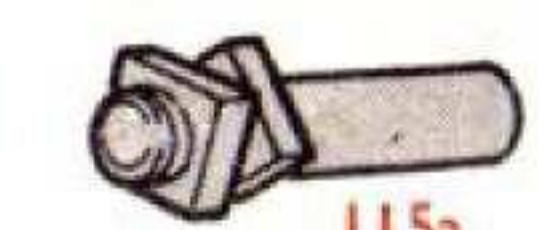

115a - 15 mm
115a long - 1½"; 34 mm
THREADED PINS



116
FORK PIECE LARGE



116a
FORK PIECE SMALL

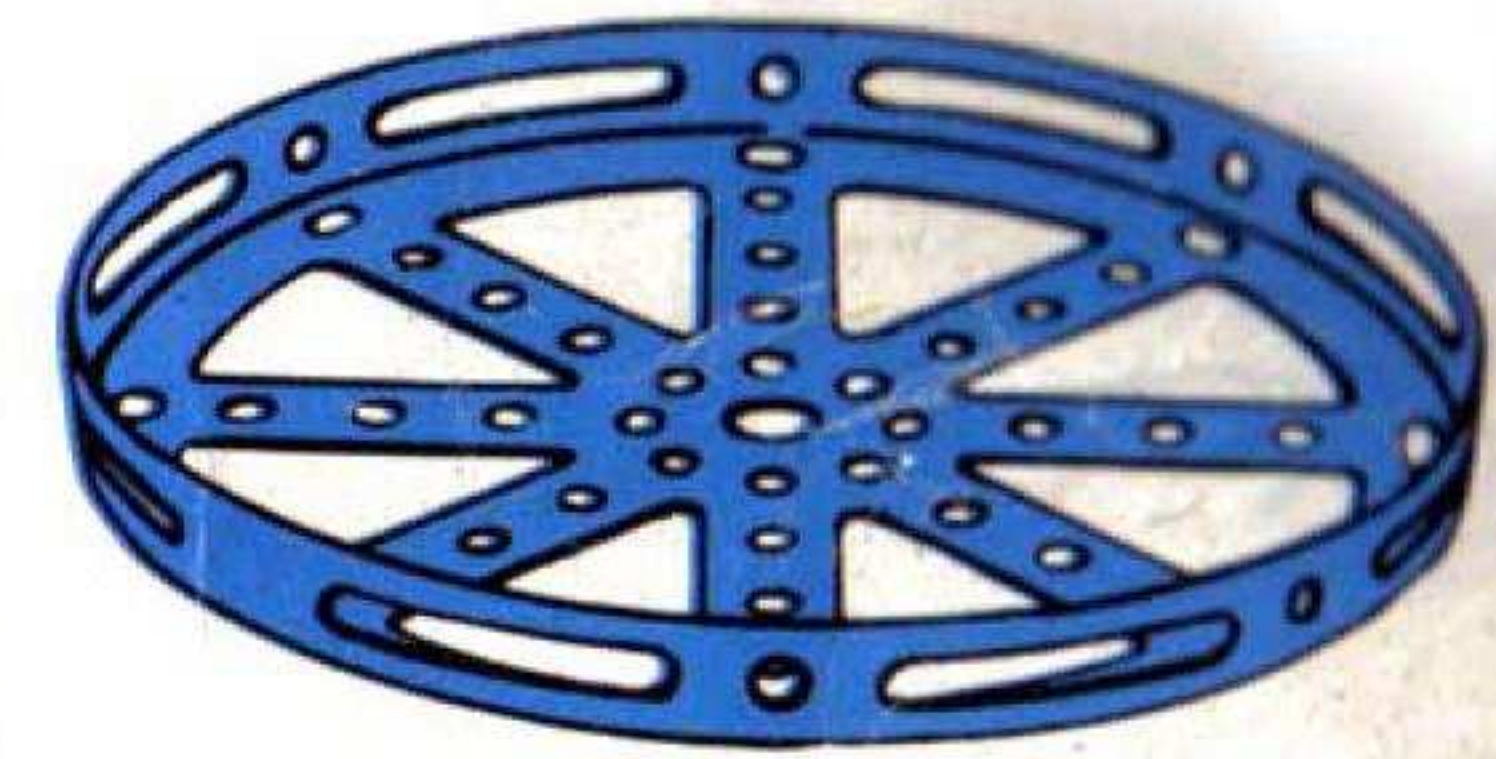

118 - 5½"; 14 cm
HUB DISC



120b - ¼"; 14 mm
COMPRESSION SPRING



122
LOADED SACK



123 - 1½" × 1" × ¾"; 32 × 25 × 19 mm
CONE PULLEY



124 - 1"; 25 mm
125 - ½"; 12 mm
REVERSED ANGLE BRACKETS

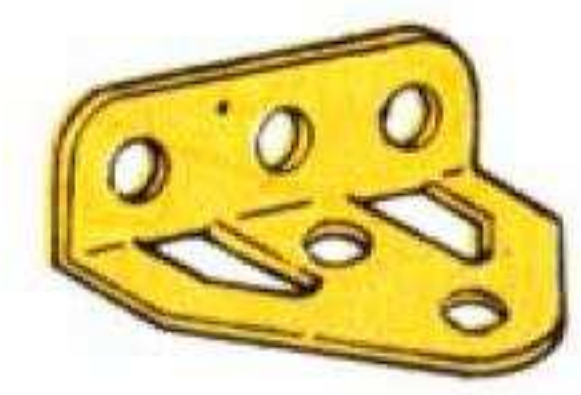

126
TRUNNION

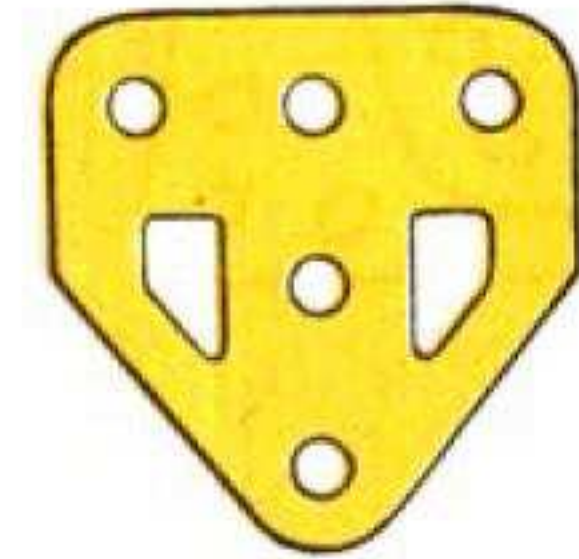

126a
FLAT TRUNNION



128
BELL CRANK



130 - ½" × ¾" × ½"; 6 × 9 × 12 mm
ECCENTRIC TRIPLE THROW



130a - ½"; 6 mm
ECCENTRIC SINGLE THROW



131
CAM

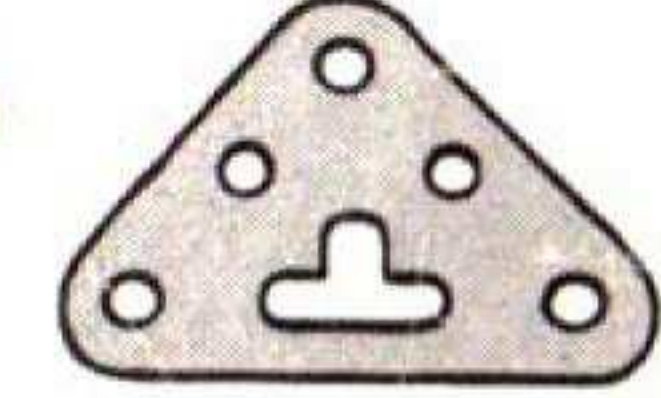

133 - 1½"; 38 mm
133a - 1"; 25 mm
CORNER BRACKETS



134 - 1"; 25 mm
CRANK SHAFT



136
HANDRAIL SUPPORT



136a
HANDRAIL COUPLING

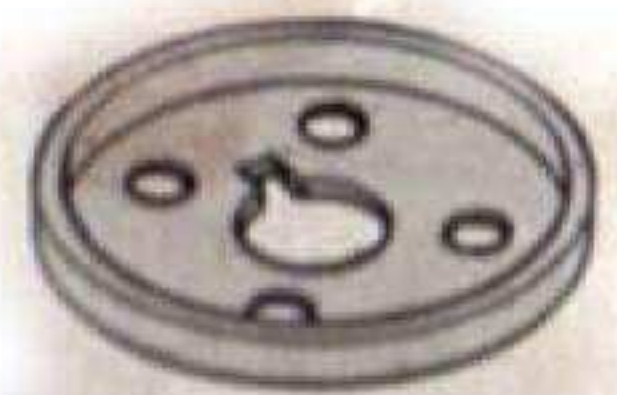

137
WHEEL FLANGE



138
SHIP'S FUNNEL



139 (right)
139a (left)
FLANGED BRACKET



140
UNIVERSAL COUPLING

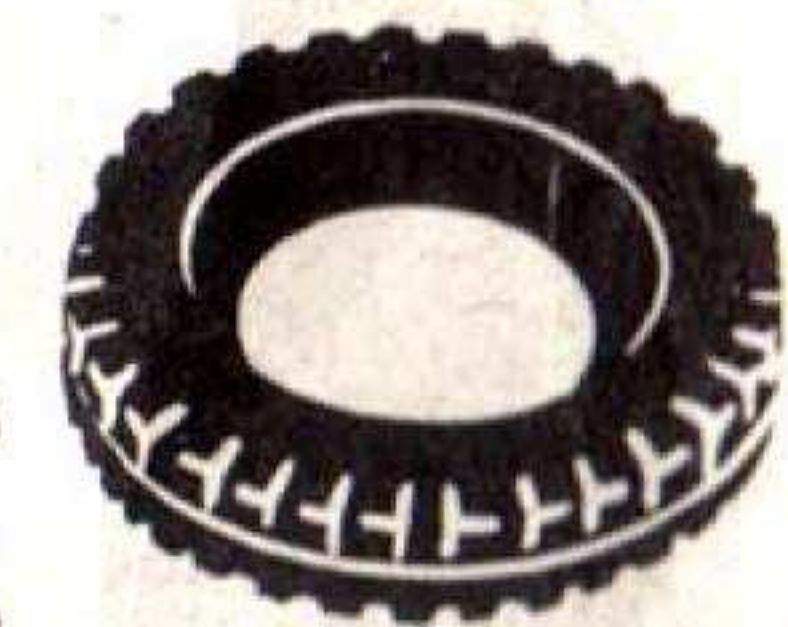

142a - 2"; 5 cm
142b - 3"; 7½ cm
142c - 1"; 25 mm
142d - 1½"; 38 mm
MOTOR TYRES



143 - 5½"; 14 cm
CIRCULAR GIRDER



144
DOG CLUTCH

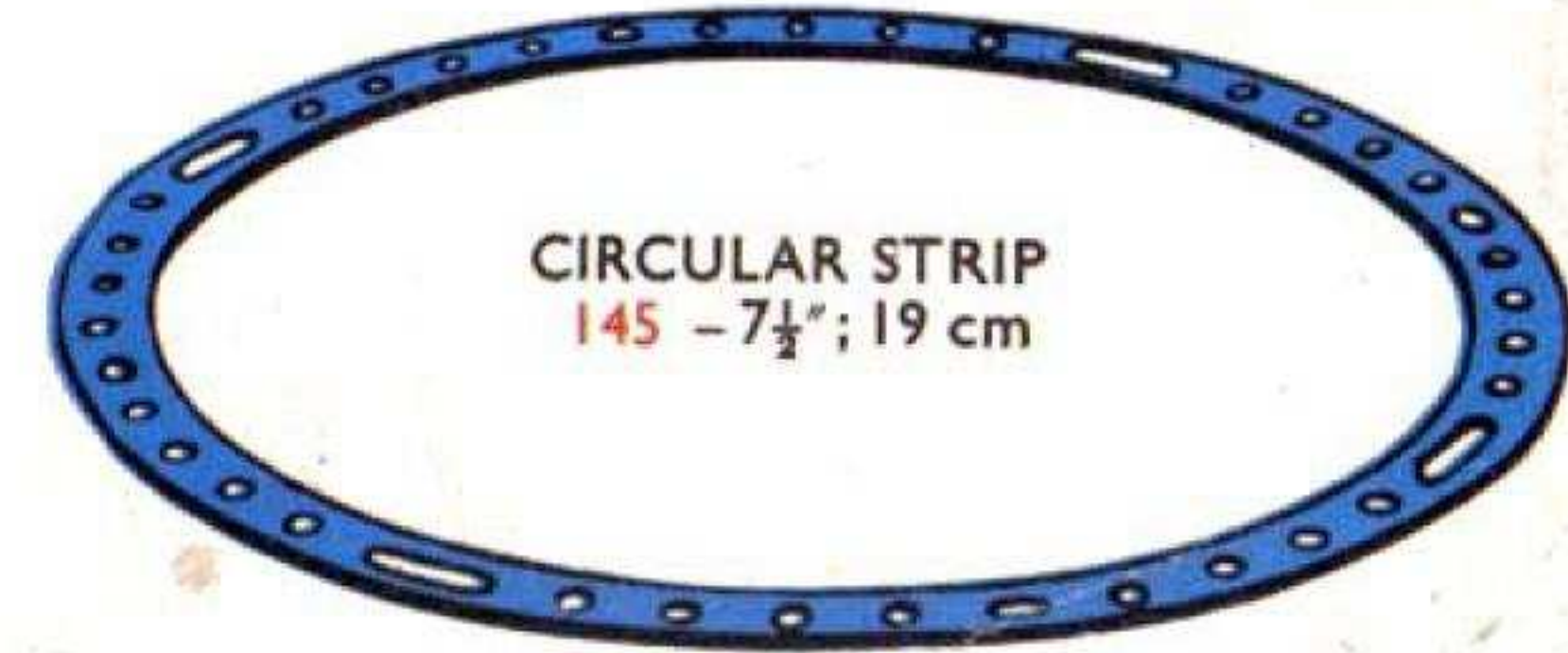

145 - 7½"; 19 cm
CIRCULAR STRIP

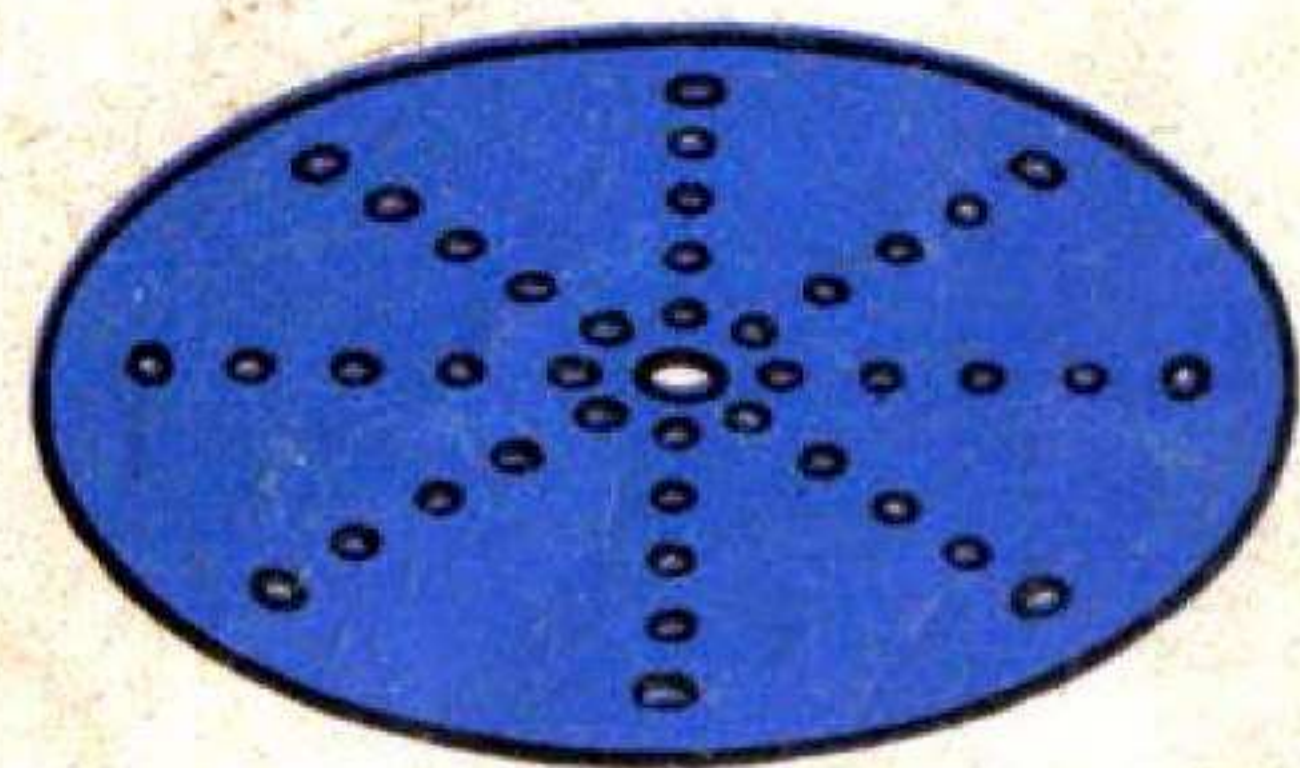

CIRCULAR PLATES
146a - 4"; 10 cm
146 - 6"; 15 cm



PAWL WITH PIVOT BOLT & NUTS
147



PAWL
147a



PIVOT BOLT
147b



147c PAWL WITHOUT BOSS



RATCHET WHEEL
148



PULLEY BLOCKS
153 TRIPLE
151 SINGLE

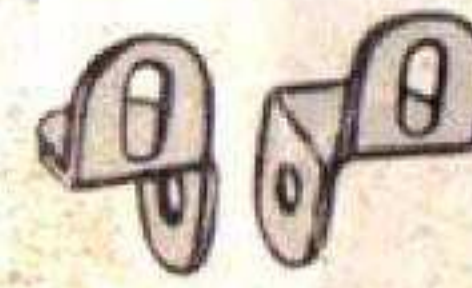

CORNER ANGLE BRACKET
154a - 1"; 12 mm (right)
154b - 1"; 12 mm (left)



RUBBER RING
155 - 1"; 25 mm



FAN
157 - 2"; 5 cm

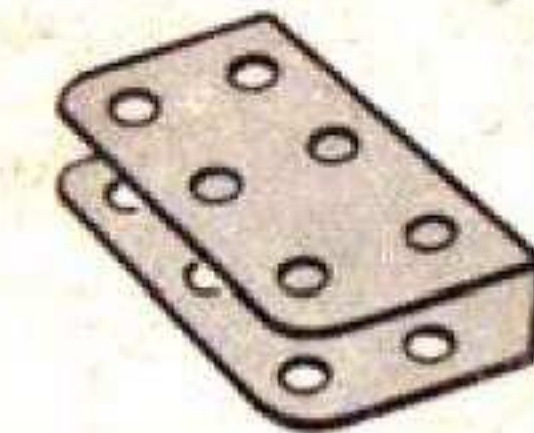

CHANNEL BEARING
160 - 1 1/2" x 1" x 1/2";
38 x 25 x 12 mm

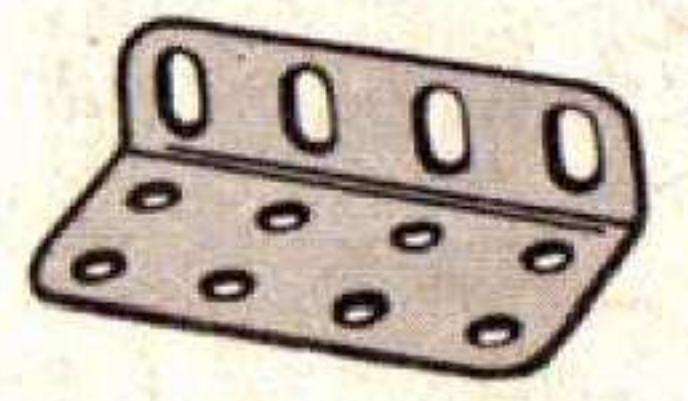

GIRDER BRACKET
161 - 2" x 1" x 1/2";
50 x 25 x 12 mm

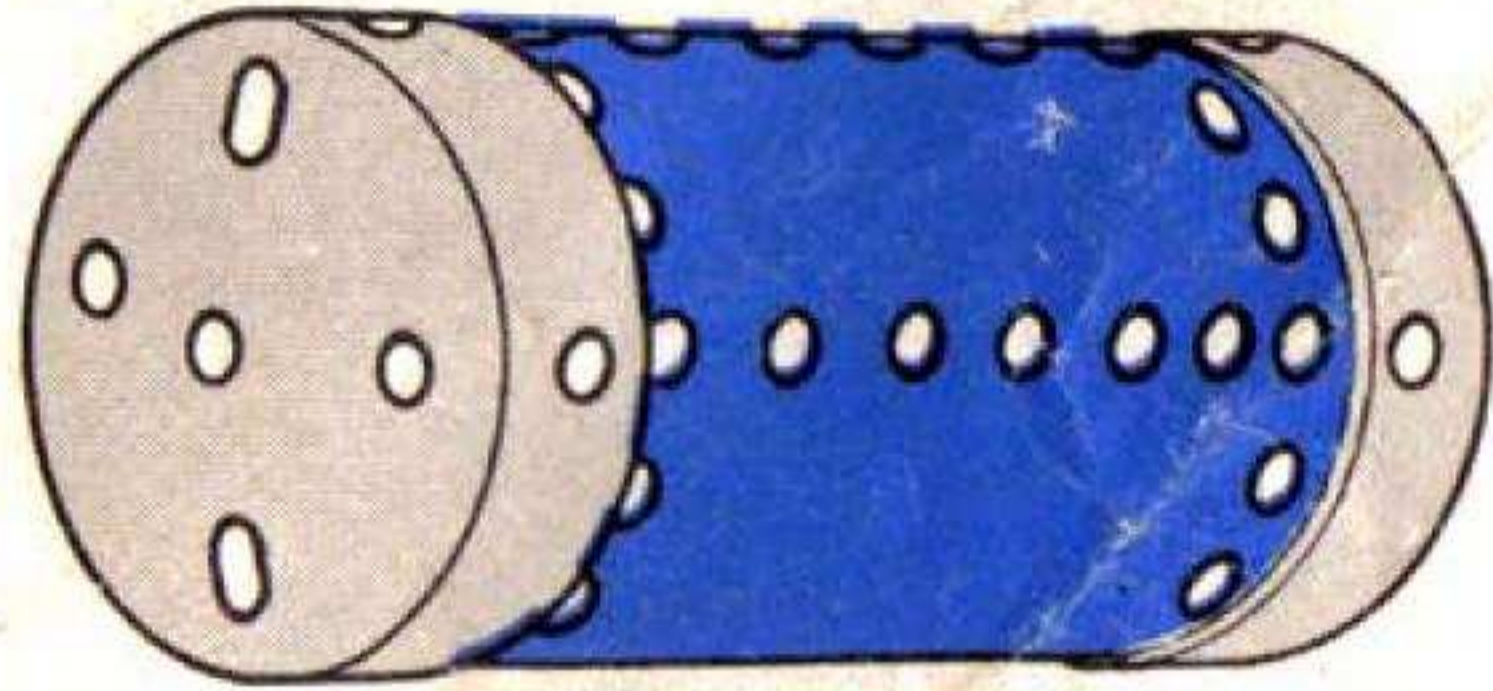

BOILER
162 BOILER COMPLETE - 5" x 2 1/2"; 12 1/2 x 5 cm
162a BOILER END - 2 1/2" x 1/2"; 50 x 19 mm

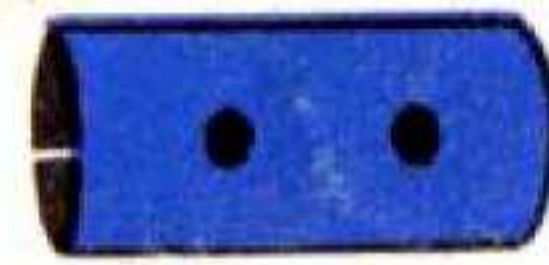

SLEEVE PIECE
163 - 1 1/2" x 1/2";
38 x 17 mm



CHIMNEY ADAPTOR
164 - 3/8" x 1/2";
16 x 12 mm



SWIVEL BEARING
165



END BEARING
166



LARGE TOOTHED QUADRANT PINION
167c

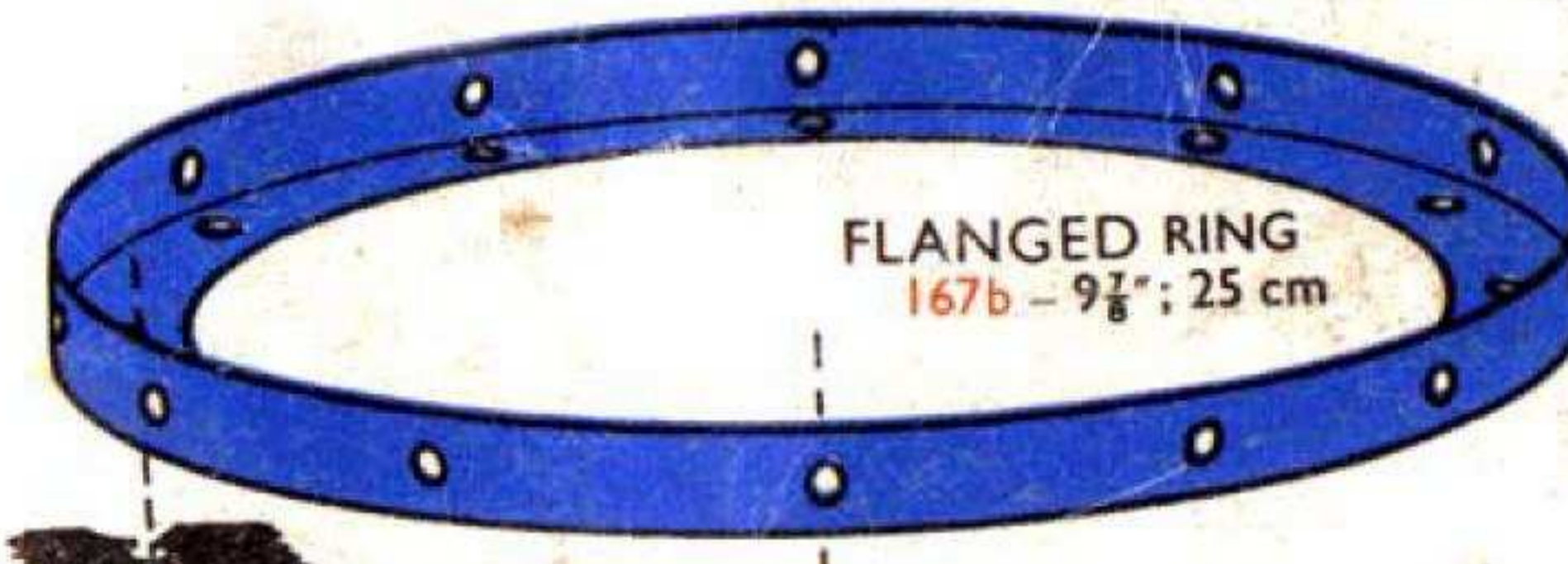

FLANGED RING
167b - 9 1/2"; 25 cm



LARGE TOOTHED QUADRANT
167a

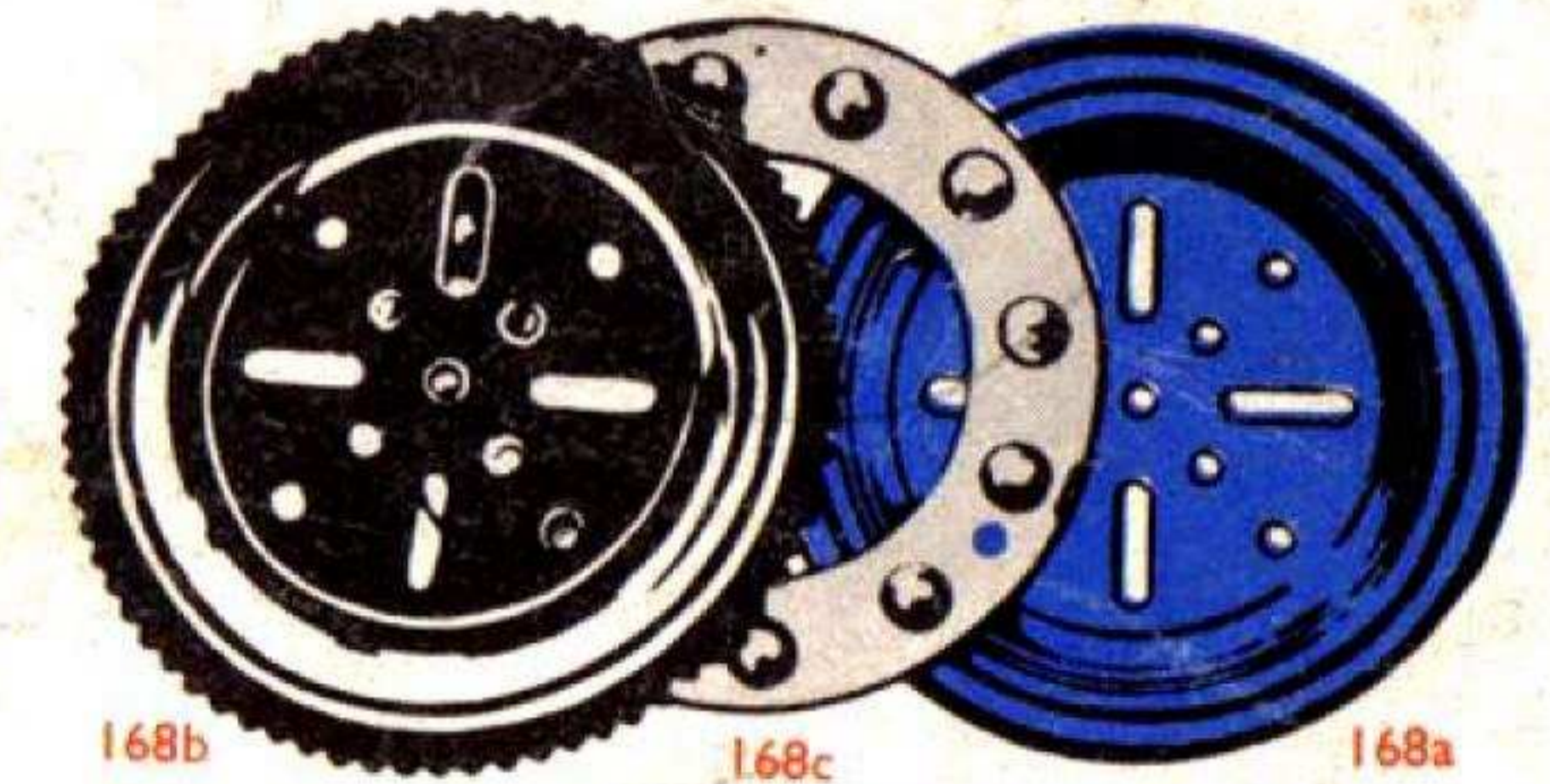

168 BALL THRUST BEARING COMPLETE 4"; 10 cm
168a AND 168b BALL THRUST RACES
168c BALL CAGE



168d BALL
3/8"; 9 1/2 mm



173a ADAPTOR FOR SCREWED ROD



179 ROD SOCKET



GEAR RING
180 - 3 1/2"; 9 cm



STEERING WHEELS
185 - 1 1/2"; 4 1/2 cm
185a - 2 1/2"; 60 mm



DRIVING BANDS
light heavy
186 - 2 1/2"; 6 cm 186c - 10"; 25 cm
186a - 6"; 15 cm 186d - 15"; 37 1/2 cm
186b - 10"; 25 cm 186e - 20"; 50 cm



ROAD WHEELS
187 - 2 1/2"; 60 mm
187b - 4 1/2"; 108 mm

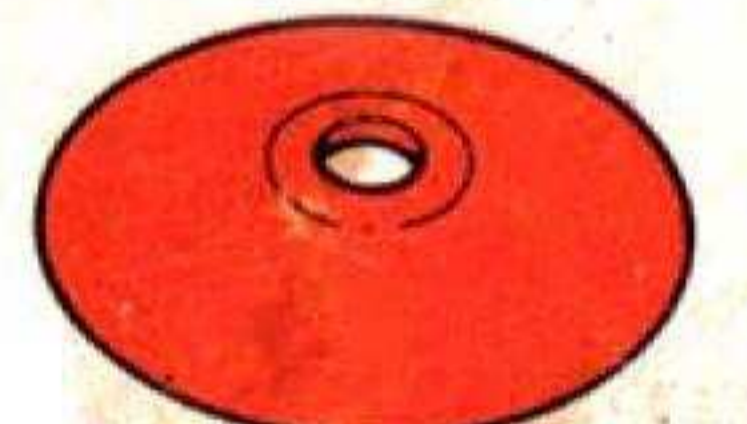

CONICAL DISC
187a - 1 1/2"; 47 mm



171 SOCKET COUPLING



176 ANCHORING SPRING



175 FLEXIBLE COUPLING UNIT

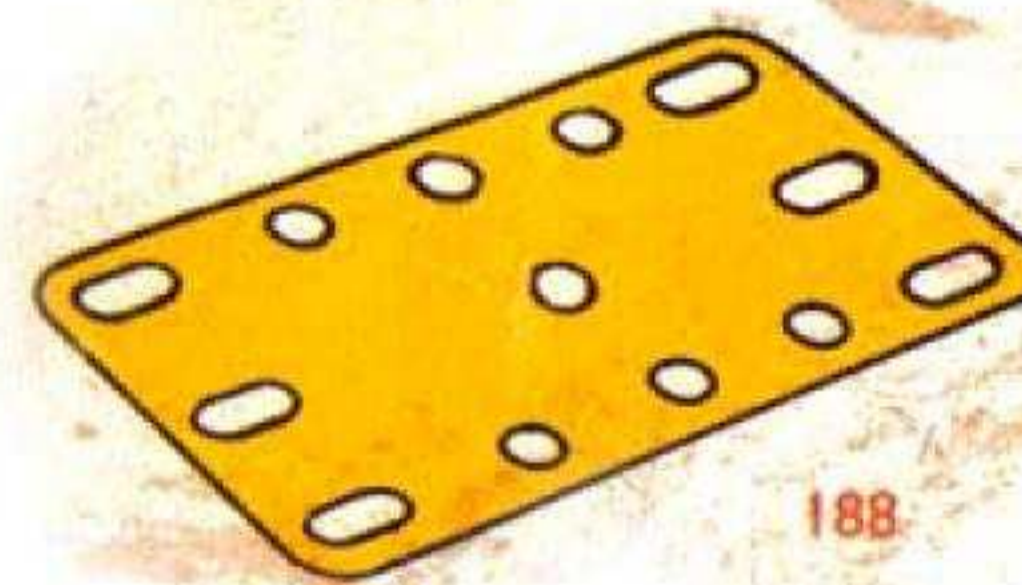

188

FLEXIBLE PLATES
188 - 2 1/2" x 1 1/2"; 60 x 38 mm
189 - 5 1/2" x 1 1/2"; 140 x 38 mm
190 - 2 1/2" x 2 1/2"; 6 x 6 cm
190a - 3 1/2" x 2 1/2"; 9 x 6 cm
191 - 4 1/2" x 2 1/2"; 11 1/2 x 6 cm
192 - 5 1/2" x 2 1/2"; 14 x 6 cm

TRANSPARENT PLATES
193 - 2 1/2" x 1 1/2"; 60 x 38 mm
193a - 2 1/2" x 2 1/2"; 60 x 60 mm

BLUE PLASTIC PLATES
193b - 3 1/2" x 2 1/2"; 90 x 60 mm
193c - 4 1/2" x 2 1/2"; 115 x 60 mm
193d - 5 1/2" x 1 1/2"; 140 x 38 mm
193e - 5 1/2" x 2 1/2"; 140 x 60 mm

STRIP PLATES
194 - 2 1/2" x 1 1/2"; 60 x 38 mm
194a - 2 1/2" x 2 1/2"; 60 x 60 mm
194b - 3 1/2" x 2 1/2"; 90 x 60 mm
194c - 4 1/2" x 2 1/2"; 115 x 60 mm
194d - 5 1/2" x 1 1/2"; 140 x 38 mm
194e - 5 1/2" x 2 1/2"; 140 x 60 mm

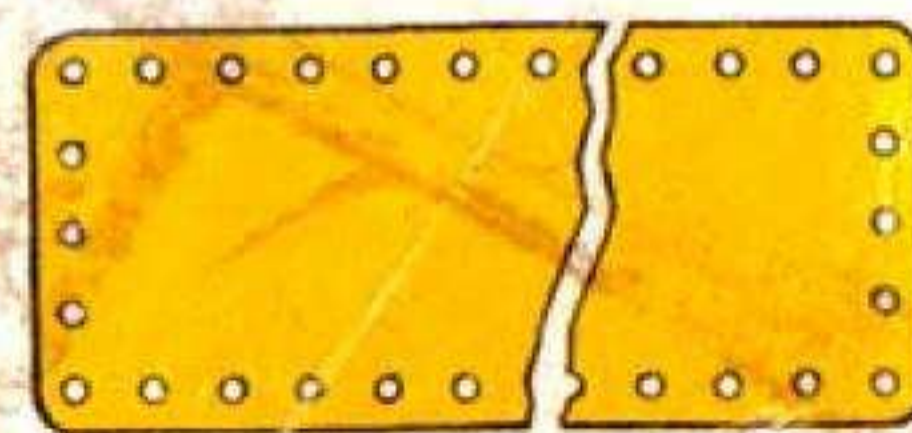

STRIP PLATES
195 - 7 1/2" x 2 1/2"; 19 x 6 cm
196 - 9 1/2" x 2 1/2"; 24 x 6 cm
197 - 12 1/2" x 2 1/2"; 32 x 6 cm

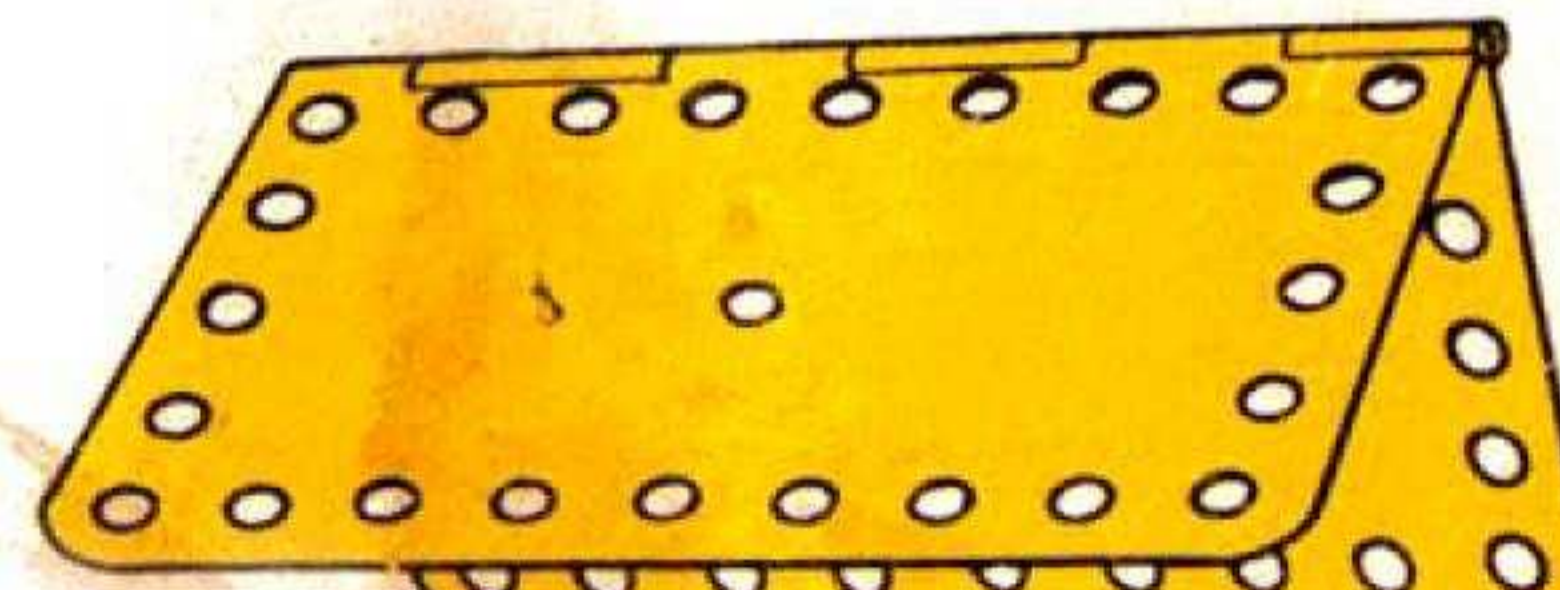

HINGED FLAT PLATE
198 - 4 1/2" x 2 1/2"; 11 1/2 x 6 cm

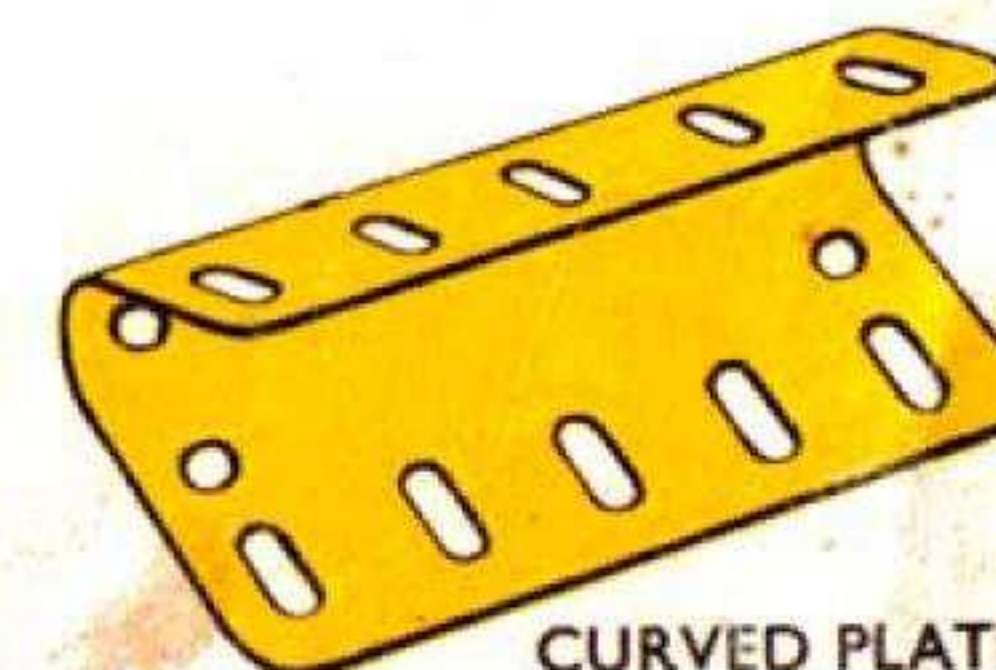

CURVED PLATE U SECTION
199 - 2 1/2" x 2 1/2" x 3/8";
60 x 60 x 7 mm

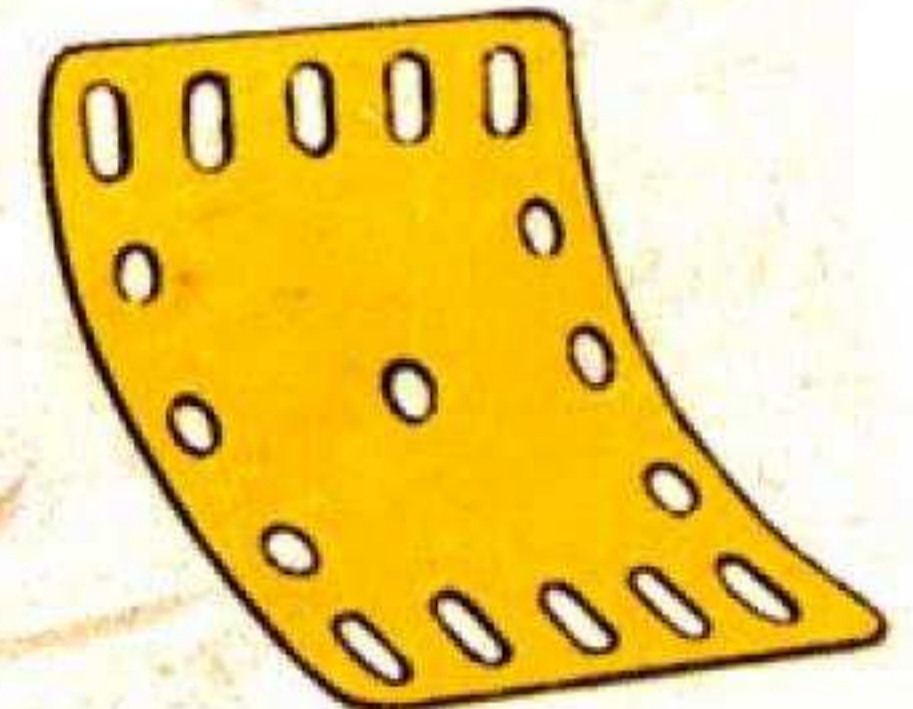

CURVED PLATE
200 - 2 1/2" x 2 1/2" x 1 1/8";
60 x 60 x 43 mm

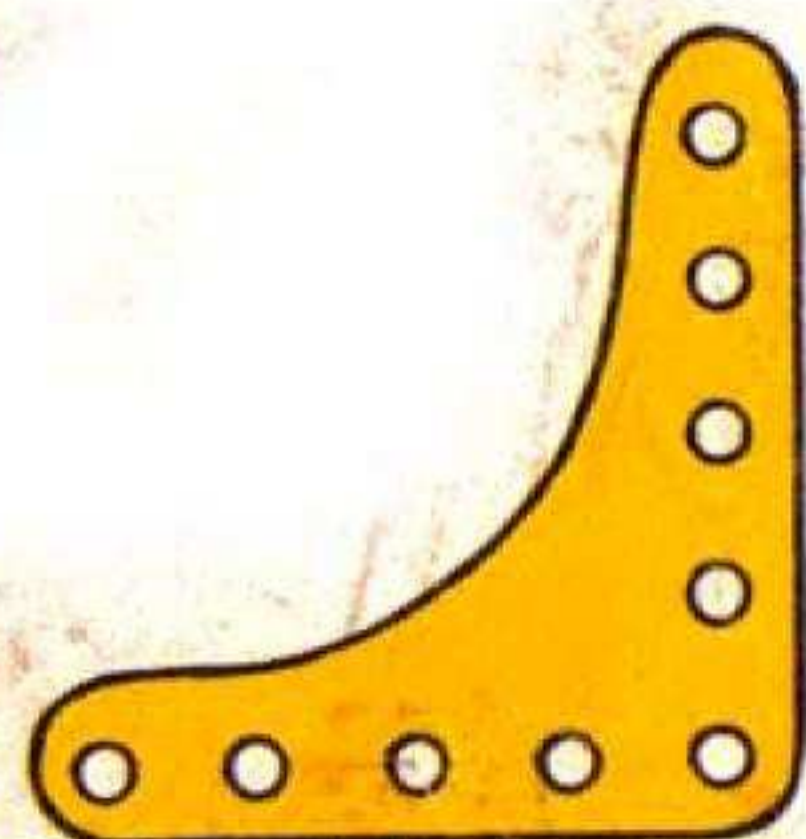

FLEXIBLE GUSSET PLATE
201 - 2 1/2" x 2 1/2";
60 x 60 mm



HELICAL GEARS
211a - 1/2"; 12 mm
211b - 1 1/2"; 38 mm
can only be used together.



212 ROD AND STRIP CONNECTOR



212a ROD AND STRIP CONNECTOR RIGHT ANGLE



213

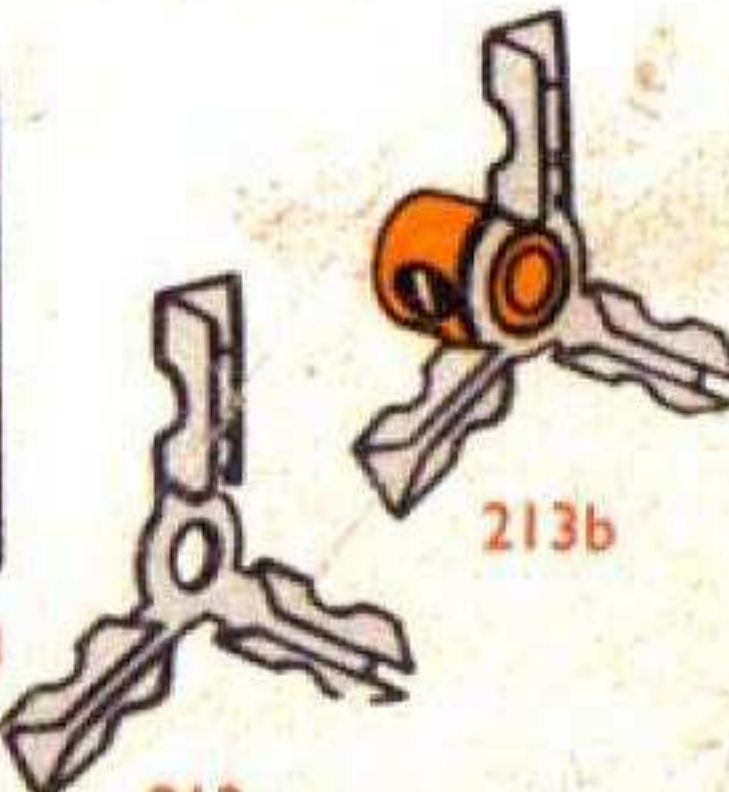

213a ROD CONNECTORS

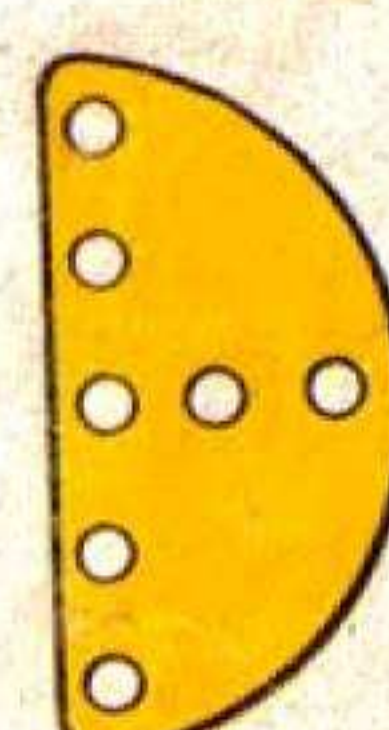

SEMI-CIRCULAR PLATE
214 - 2 1/2"; 6 cm

FORMED SLOTTED STRIP
215 - 3"; 7 1/2 cm

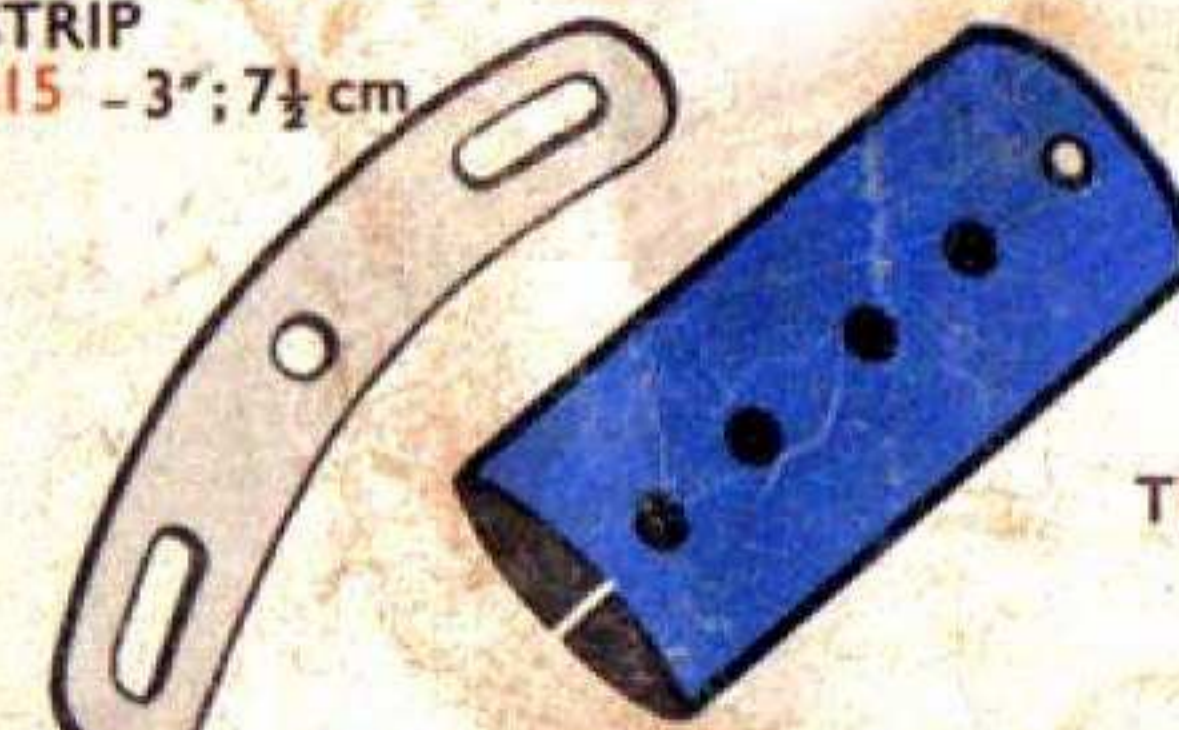

CYLINDER
216 - 2 1/2" x 1 1/2";
60 x 30 mm

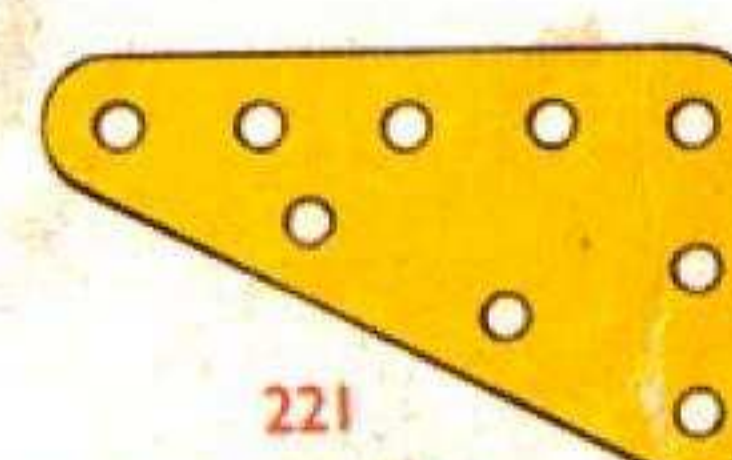

221

TRIANGULAR FLEXIBLE PLATES
221 - 2 1/2" x 1 1/2"; 60 x 38 mm
222 - 2 1/2" x 2"; 60 x 50 mm
223 - 2 1/2" x 2 1/2"; 60 x 60 mm
224 - 3 1/2" x 1 1/2"; 90 x 38 mm
225 - 3 1/2" x 2"; 90 x 50 mm
226 - 3 1/2" x 2 1/2"; 90 x 60 mm

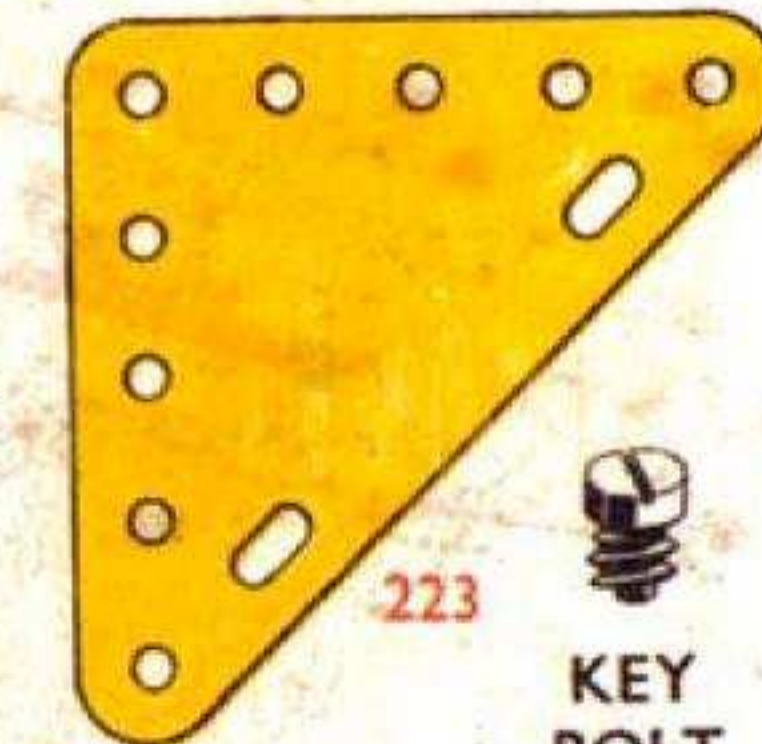

231 KEY BOLT



230 ROD WITH KEYWAY
- 4"; 10 cm

NARROW STRIPS
235 - 2 1/2" x 1 1/2"; 60 mm x 9 mm
235a - 3" x 1 1/2"; 75 mm x 9 mm
235b - 3 1/2" x 1 1/2"; 90 mm x 9 mm
235d - 4 1/2" x 1 1/2"; 115 mm x 9 mm
235f - 5 1/2" x 1 1/2"; 140 mm x 9 mm