



MECCANO[®]



**BOOK OF MODELS
VOORBEELDENBOEK
LIVRE DES MODÈLES
LIBRO DEI MODELLI
MODELLBUCH
MODELLBOK
LIBRO DE MODELOS
LIVRO DE MODELOS
MODELLBOK**

4EL

CONTENTS OF MECCANO 4EL SET

Part No.	Standard Parts	Quantity	Part No.	Standard Parts	Quantity
1	Perforated Strip, 12 1/2" x 32 cm	2	1	Perforated Strip, 12 1/2" x 32 cm	2
2	" " 5 1/2" x 14 cm	6	2	" " 5 1/2" x 14 cm	2
5	" " 2 1/2" x 6 cm	9	3	" " 3 1/2" x 9 cm	2
10	Fishplate	10	5	" " 2 1/2" x 6 cm	3
11	Double Bracket, 1" x 1 1/2"; 12 x 12 mm	2	6a	" " 1 1/2" x 38 mm	2
12	Angle Bracket, 1" x 1 1/2"; 12 x 12 mm	12	8	Angle Girder, 12 1/2" x 32 cm	2
12b	" " 1" x 1 1/2"; 25 x 12 mm	2	11	Double Bracket, 1" x 1 1/2"; 12 x 12 mm	2
12c	" " 1" x 1 1/2"; 25 x 12 mm	2	11a	" " 1" x 1 1/2"; 12 x 12 mm	2
15b	Axle Rod, 4"; 10 cm	3	12	Angle Bracket, 1" x 1 1/2"; 12 x 12 mm	1
16	" " 3 1/2" x 9 cm	1	12a	" " 1" x 1 1/2"; 25 x 25 mm	10
16b	" " 3" x 7 1/2 cm	2	12b	" " 1" x 1 1/2"; 25 x 12 mm	2
17	" " 2" x 5 cm	2	12c	Obtuse Angle Bracket, 1" x 1 1/2"; 12 x 12 mm	2
18a	" " 1 1/2" x 38 mm	1	15	Axle Rod, 5"; 13 cm	1
18b	" " 1" x 25 mm	1	15a	" " 4 1/2" x 11 1/2 cm	1
19b	Pulley, 3" diam. with boss and set screw; 7 1/2 cm	1	16	" " 3 1/2" x 9 cm	1
19s	Crank Handle, 3 1/2" shaft; 13 cm	1	18a	" " 1 1/2" x 38 mm	1
20a	Pulley, 2" diam. with boss and set screw; 5 cm	1	18b	" " 1" x 25 mm	1
22	Pulley, 1" diam. with boss and grub screw; 25 mm	4	19b	Pulley, 3" diam. with boss and set screw; 7 1/2 cm	1
22a	Pulley, 1" diam. without boss; 25 mm	2	19s	Crank Handle, 3 1/2" shaft; 9 cm	1
23	Pulley, 1/2" diam. without boss; 12 mm	1	26	Pinion, 1" diam., 1/2" face, 19 teeth with grub screw; 12 x 6 mm	1
24	Bush Wheel, 1 1/2" diam., 8 holes with set screw; 34 mm	2	35	Spring Clip	1
24a	Wheel Disc, 1 1/2" diam. without boss, 8 holes; 34 mm	2	37a	Nut	70
27f	Multi-purpose Gear Wheel, 14 teeth with grub screw	2	37b	Bolt, 3/4"; 5 mm	60
34	Spanner	2	38	Washer, 3/4" diam.; 10 mm	32
35	Spring Clip	2	38d	" " 3/4" diam.; 19 mm	1
36	Screwdriver	10	40	Hank of Cord	1
37a	Nut	134	48a	Double Angle Strip, 2 1/2" x 1 1/2"; 60 x 12 mm	2
37b	Bolt, 3/4"; 5 mm	94	52	Flanged Plate, 5 1/2" x 2 1/2"; 14 x 6 cm	1
38	Washer, 3/4" diam.; 10 mm	56	57c	Hook Loaded	1
38d	" " 3/4" diam.; 19 mm	2	59	Collar with grub screw	1
40	Hank of Cord	1	99a	Curved Strip, Stepped 2 1/2"; Radius 1 1/2"; 6 cm, 35 mm	4
48a	Double Angle Strip, 2 1/2" x 1 1/2"; 60 x 12 mm	2	111	Bolt, 1/2"; 90 mm	4
52	Flanged Plate, 5 1/2" x 2 1/2"; 14 x 6 cm	1	111a	" " 1/2"; 12 mm	8
57c	Hook Loaded	1	111c	" " 1/2"; 9 1/2 mm	13
59	Collar with grub screw	1	111d	" " 1 1/2"; 28 1/2 mm	4
99a	Curved Strip, Stepped 2 1/2"; Radius 1 1/2"; 6 cm, 35 mm	4	115	Threaded Pin	2
111	Bolt, 1/2"; 90 mm	4	120b	Compression Spring, 1/4"; 14 mm	1
111a	" " 1/2"; 12 mm	8	125	Reversed Angle Bracket, 1/2"; 12 mm	2
111c	" " 1/2"; 9 1/2 mm	13	126	Trunnion	2
111d	" " 1 1/2"; 28 1/2 mm	4	126a	Flat Trunnion	2
115	Threaded Pin	2	140y	Joint-Universal Coupling	2
120b	Compression Spring, 1/4"; 14 mm	1	142c	Motor Tyre to fit 1" diam. rim; 25 mm	4
125	Reversed Angle Bracket, 1/2"; 12 mm	2	147b	Pivot Bolt with 2 Nuts	1
126	Trunnion	2	155	Rubber Ring for 1" Pulley; 25 mm	2
126a	Flat Trunnion	2	176	Anchoring Spring for Cord	1
140y	Joint-Universal Coupling	2	186	Driving Band, 2 1/2" light; 6 cm	1
142c	Motor Tyre to fit 1" diam. rim; 25 mm	4	186a	" " 6" light; 15 cm	1
147b	Pivot Bolt with 2 Nuts	1	186b	" " 10" light; 25 cm	2
155	Rubber Ring for 1" Pulley; 25 mm	2	188	Flexible Plate, 2 1/2" x 1 1/2"; 60 x 38 mm	2
176	Anchoring Spring for Cord	1	189	" " 5 1/2" x 1 1/2"; 140 x 38 mm	2
186	Driving Band, 2 1/2" light; 6 cm	1	190	" " 2 1/2" x 2 1/2"; 6 x 6 cm	2
186a	" " 6" light; 15 cm	1	191	" " 4 1/2" x 2 1/2"; 11 1/2 x 6 cm	2
186b	" " 10" light; 25 cm	2	192	" " 5 1/2" x 2 1/2"; 14 x 6 cm	2
188	Flexible Plate, 2 1/2" x 1 1/2"; 60 x 38 mm	2	193	Transparent Plastic Plate, 2 1/2" x 1 1/2"; 60 x 38 mm	2
189	" " 5 1/2" x 1 1/2"; 140 x 38 mm	2	194	Blue Plastic Plate, 2 1/2" x 1 1/2"; 60 x 38 mm	2
190	" " 2 1/2" x 2 1/2"; 6 x 6 cm	2	194a	" " 2 1/2" x 2 1/2"; 60 x 60 mm	2
191	" " 4 1/2" x 2 1/2"; 11 1/2 x 6 cm	2	199	Curved Plate U-section, 2 1/2" x 2 1/2" x 3/5" radius; 60 x 60 x 7 mm	1
192	" " 5 1/2" x 2 1/2"; 14 x 6 cm	2	200	" " 2 1/2" x 2 1/2" x 1 1/4" radius; 60 x 60 x 43 mm	1
193	Transparent Plastic Plate, 2 1/2" x 1 1/2"; 60 x 38 mm	2	212	Rod and Strip Connector	1
194	Blue Plastic Plate, 2 1/2" x 1 1/2"; 60 x 38 mm	2	213	Rod Connector	1
194a	" " 2 1/2" x 2 1/2"; 60 x 60 mm	2	214	Semi-Circular Plate, 2 1/2"; 6 cm	2
199	Curved Plate U-section, 2 1/2" x 2 1/2" x 3/5" radius; 60 x 60 x 7 mm	1	215	Formed Slotted Strip, 3"; 7 1/2 cm	4
200	" " 2 1/2" x 2 1/2" x 1 1/4" radius; 60 x 60 x 43 mm	1	221	Triangular Flexible Plate, 2 1/2" x 1 1/2"; 60 x 38 mm	4
212	Rod and Strip Connector	1	501	Electrical Parts	2
213	Rod Connector	1	502	Insulating Strip, 5 1/2"; 14 cm	2
214	Semi-Circular Plate, 2 1/2"; 6 cm	2	503	" " 2 1/2"; 6 cm	2
215	Formed Slotted Strip, 3"; 7 1/2 cm	4	507	Insulating Flat Girder, 2 1/2"; 6 cm	1
221	Triangular Flexible Plate, 2 1/2" x 1 1/2"; 60 x 38 mm	4	508	Insulating Plate, 5 1/2" x 2 1/2"; 14 x 6 cm	1
501	Electrical Parts	2	511	Insulating Plate, 5 1/2" x 2 1/2"; 6 x 6 cm	1
502	Insulating Strip, 5 1/2"; 14 cm	2	513	" " Fishplate	2
503	" " 2 1/2"; 6 cm	2	514	" " Bush Wheel, 8 holes	1
507	Insulating Flat Girder, 2 1/2"; 6 cm	1	516	" " Bush Wheel, 1" diam.; 25 mm	1
508	Insulating Plate, 5 1/2" x 2 1/2"; 14 x 6 cm	1	518	" " Bush Wheel, 1" diam.; 25 mm	1
511	Insulating Plate, 5 1/2" x 2 1/2"; 6 x 6 cm	1	532	Slotted Strip, 2"; 5 cm	2
513	" " Fishplate	2	530	Flexible Strip, 2"; 5 cm	2
514	" " Bush Wheel, 8 holes	1	531	Wiper Arm, 1" Radius Flexible; 25 mm	2
516	" " Bush Wheel, 1" diam.; 25 mm	1	532	Slotted Strip, 2"; 5 cm	2
518	" " Bush Wheel, 1" diam.; 25 mm	1	533	Wiper Arm, 1" Radius Flexible	2
532	Slotted Strip, 2"; 5 cm	2	534	Slotted Strip, 2"; 5 cm	2
533	Wiper Arm, 1" Radius Flexible	2	537	Permanent Magnet	2
534	Slotted Strip, 2"; 5 cm	2	538	Magnet Holder	2
537	Permanent Magnet	2	539	Lamp Holder	4
538	Magnet Holder	2	540c	Lamp, Clear	1
539	Lamp Holder	4	540j	" Yellow	1
540c	Lamp, Clear	1	540r	" Red	1
540j	" Yellow	1	540v	" Green	1
540r	" Red	1	542	Terminal Nut	4
540v	" Green	1	543	Contact Screw	2
542	Terminal Nut	4	544	" Stud	8
543	Contact Screw	2	545	Pivot Bolt, 1/2"; 12 mm	2
544	" Stud	8	548	Pivot Rod, 3/4"; 9 cm	1
545	Pivot Bolt, 1/2"; 12 mm	2	549	" " 2"; 5 cm	1
548	Pivot Rod, 3/4"; 9 cm	1	550	Short Pivot	2
549	" " 2"; 5 cm	1	551	Flat Commutator	1
550	Short Pivot	2	554	Short Circuit Piece	2
551	Flat Commutator	1	555	Rod with Square End, 4"; 10 cm	1
554	Short Circuit Piece	2	556	Reel of PVC Insulating Sleeving	1
555	Rod with Square End, 4"; 10 cm	1	557	" Bare Copper Wire	1
556	Reel of PVC Insulating Sleeving	1	558	Coil of Connecting Wire	1
557	" Bare Copper Wire	1	559	Coil of Paper	1
558	Coil of Connecting Wire	1	560	Dial Card	13
559	Coil of Paper	1	561	Washer, Thin	1
560	Dial Card	13	562	Bell	1
561	Washer, Thin	1	563	Screwed Rod, 2"; 5 cm	2
562	Bell	1	564	Insulating Spacer	2
563	Screwed Rod, 2"; 5 cm	2	570	Bottle of Oil	2
564	Insulating Spacer	2			
570	Bottle of Oil	2			

Additional parts required to build models E34, E36 and E37 shown in this book

More New Models for You to Build!

New and fascinating models designed for construction from electrical and standard Meccano Parts are illustrated and described from time to time in the *Meccano Magazine*, published monthly. A Postcard to: The Editor, *Meccano Magazine*, Model and Allied Publications Ltd, 13-35 Bridge Street, Hemel Hempstead, Hertfordshire, will bring you full particulars of how to obtain this publication.

Meccano 4EL SET

Please Read Before Starting to Build

The Meccano 4EL Set is a self-contained Outfit made up of special electrical parts combined with the standard Meccano No. 4 Set and a quantity of extra standard parts that together enable a variety of interesting electrical equipment to be built, as well as allowing suitable standard models to be electrified. Shown in this book are a large number of suggested constructions, all of which can be built with the 4EL Set, *except for models E34, E36 and E37* for which some additional parts are needed. A list of these additional parts is given on the inside front cover of this book and all can be purchased separately as can any Meccano part, standard or electrical.

The various models illustrated in this book are designed to work from low voltage; between 4 and 15 volts Direct Current (DC) or Alternating Current (AC) so that no danger is involved. Some of the models requiring Direct Current (DC) can be worked from a single 4.5 volt battery (see list on page 2), while those which require a higher voltage can be run from one of the following sources:

- two or more low-voltage batteries connected together in series;
- a transformer/rectifier such as one of the popular model railway power control units, most of which have a suitable output;
- the Meccano Battery Control Box;
- the Meccano Hand Generator;
- an accumulator of suitable voltage, such as a car battery, although in this case a 1 amp fuse should be connected in series in the circuit so as to protect both the wiring and accumulator from damage in the case of short circuiting.

Some of the models in this book will operate from Alternating Current (AC) only, which can be obtained from AC mains *through a suitable transformer. Under no circumstances must a model be connected direct to a mains supply.*

The particular current and voltage supply required for each model is indicated in all cases, but please note that no power source is included in the 4EL Set. This must be obtained separately.

How to identify the parts in this Outfit

On the back cover of this book you will find listed and illustrated most of the Meccano electrical parts, together with their names and catalogue numbers. The principal Meccano standard parts used in the construction of the models shown in this book are illustrated on cover page 3.

It will help you to remember that the Meccano standard parts are numbered from 1 to 235, while the Meccano electrical parts are numbered from 501 upwards.

The parts used in the models usually can be identified by looking at the illustrations, but where the identity of a part may not be quite clear, its catalogue number is printed on the assembly drawing.

If you see in the illustrations a combination of figures such as 5(6) it means that 6 of part 5 are to be used. Similarly the figures 2(3) indicate that 3 of part 2 are to be used.

Each model is accompanied by a list of the parts required to build it. In this list the catalogue number of the part is printed in *Red* and the quantity required in *Black*.

Electrical part 560 Dial Card, is a printed card comprising dials, discs, hands, etc, each of which is marked with a letter. If you see, for example, the number '560d' in the list of parts for a model it refers to the disc marked 'Impulse Counter' on this card. The Dial, 560f, is not used in any of the models shown in this book, but will come in useful when building models of your own that require a dial.

How to Build and Wire the Models

You should first assemble the chosen model by following the explanatory drawings and photographs. Then proceed to 'wire up' the model as indicated by the *Red* lines on the drawings, or by the special wiring diagram, if one is given. *Normally wiring is done with Bare Copper Wire No. 557, which must be covered with the PVC Insulating Sleeving No. 556.* In cases where the thin Connecting Wire 558 is used, the number 558 is printed on the diagrams.

The terminals of your battery or Power Control Unit should be connected to the terminals of your model marked 'G' in the illustrations.

To make a connection with Bare Copper Wire 557, first form a loop by bending the wire around a rod. Cut off the length required, with a pair of old scissors or a wire cutter and then slip the wire through a piece of PVC Insulating Sleeving (556) of the correct length, and finally, form the terminal loop at the other end.

If a model includes revolving rods or other moving parts it is a good plan to apply a little thin oil to the bearings, before setting the model in motion. Never allow oil to drop on the contacts or terminals of a model, however, because oil forms an insulating film and might give rise to a faulty connection.

In some models it is necessary to join two Strips or other parts together in such a way that they are free to pivot or move in relation to each other. This is usually done by passing a bolt through the parts and then fitting it with two nuts. The nuts are then tightened together by turning them in opposite directions but care is taken to see that nuts do not grip the parts tightly. Before attempting to set your models working make sure that all parts and rods which have to move or rotate do so quite freely. Otherwise the model may refuse to work when the current supply is connected to it. Make sure that all bearings are exactly in line and apply a little oil to them and to all points where one or more parts are pivoted together.

If your model refuses to work you should check up the construction and make especially sure that the electrical connections are exactly as shown in the illustrations.

Never attempt to bend the insulating parts 501, 502, 503, 510 and 511.

Important Information

You should study the following notes carefully as they will enable you to get the utmost pleasure and instruction from the models you build with your 4EL Set.

Permanent Magnet (Electrical Part No. 537)
The Meccano electrical part 537, is what is known as a permanent magnet which means that it is constantly energized. A magnet has two poles, known as 'North' and 'South' poles. The 'North' poles of the Permanent Magnets are painted RED and are shown shaded in the drawings in the book.

You should be very careful to follow this indication in building your models as it is very important.

Never place two magnets together with their 'North' or 'South' poles coinciding. They should always be stored away with the 'North' (Red) pole of one coinciding with the 'South' pole of the other (see Fig. 1).

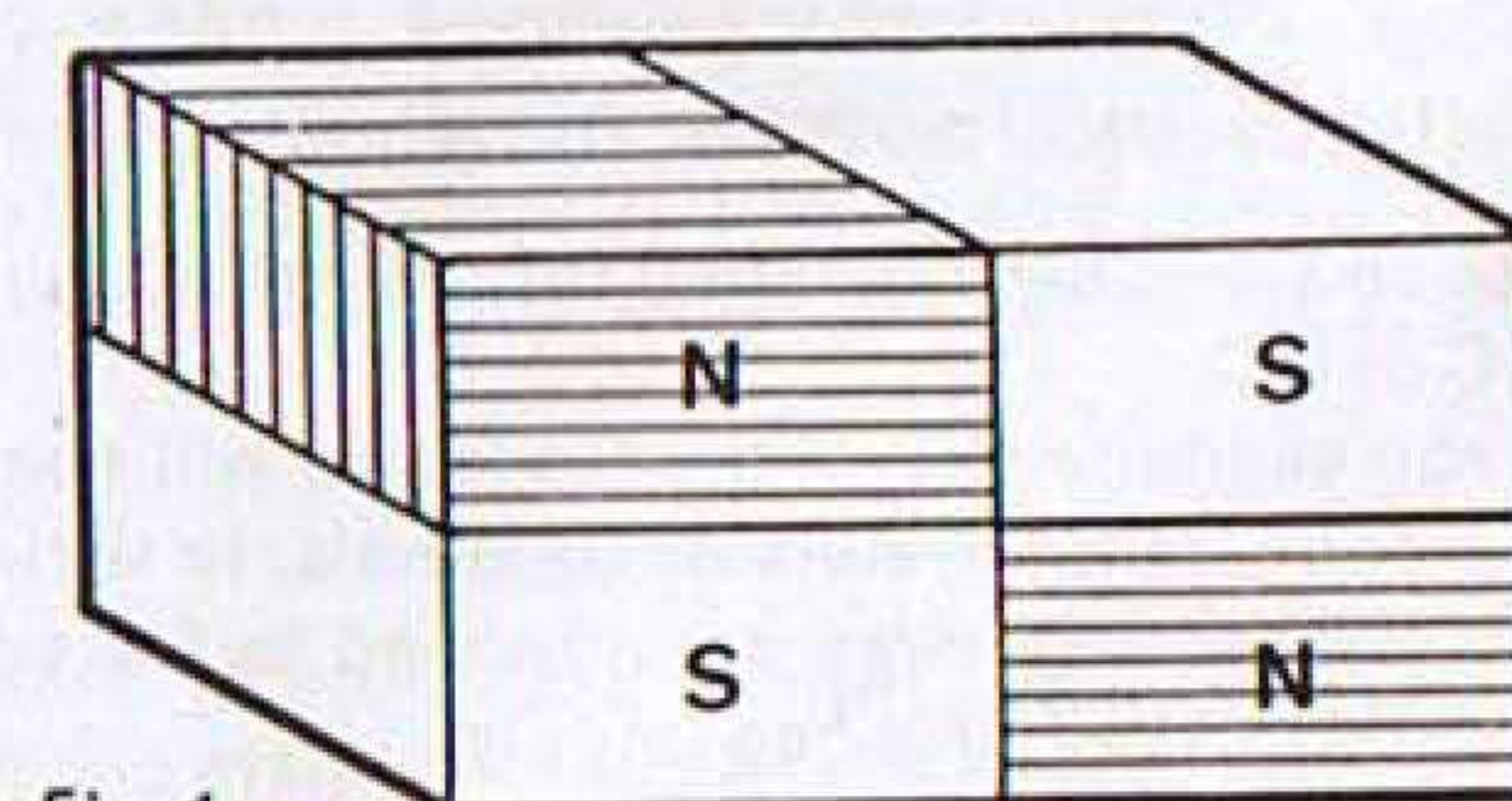

Fig. 1

You should never introduce a Permanent Magnet into a Coil which is connected to a current supply. If you do you will run the risk of de-magnetizing your magnet.

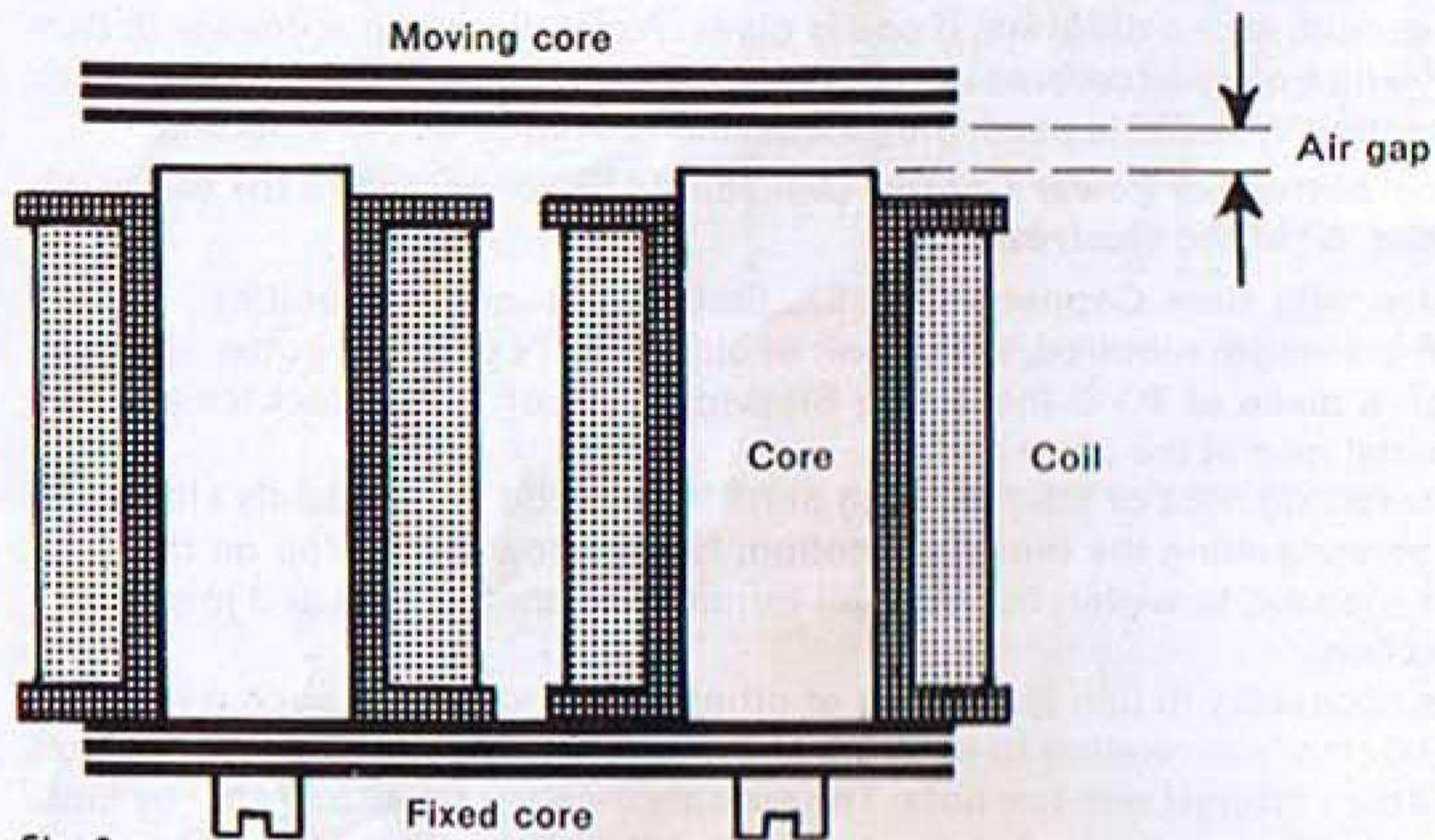

Fig. 2

Electro-Magnets

Unlike a permanent magnet, such as part 537, an electro-magnet is not constantly magnetized or 'alive'. It consists of a core of soft iron which is placed in the centre of an insulated copper wire coil, through which current from a battery or other suitable source can be passed. As soon as the current is switched on the 'core' becomes magnetized and remains so until the current is switched off again, when it once more becomes de-magnetized.

Electro-magnets (so far as our models are concerned) can be single or double. In the case of a double magnet, the two cores are connected at one end by Meccano Strips, which form a yoke, or magnetic path, and their other free ends form the 'North' and 'South' poles. They can be used to produce a mechanical motion by means of a moving core (see Fig. 2).

Another use for an electro-magnet is shown in Fig. 3, which shows a Core free to move inside its Coil. If the Core is pushed about one-third of its length into the Coil and the current is then switched on, the Core will be 'sucked' right into the Coil.

Coils (Electrical parts 520, Rectangular, with base, and 522, Cylindrical)

These Coils are designed for use with a current supply at 4 to 6 volts, which may be either AC or DC.

If you examine one of the Coils you will see that it carries the letters E (in) and S (out) near the connecting eyelets or terminals. In wiring your models it is important to make sure that the connecting wires are attached to the correct eyelets. Bolts passed through the eyelets should not be tightened unduly.

Coils should not be kept continuously fed with current, otherwise they may tend to overheat.

The 'Air Gap'

So far as the models in this book are concerned the term 'Air Gap' refers to the space between two magnetic cores, one stationary and the other movable. The extent of this gap varies

according to the requirements of a particular model, and is usually measured either by the thickness of a Meccano Strip or of parts 531 or 532.

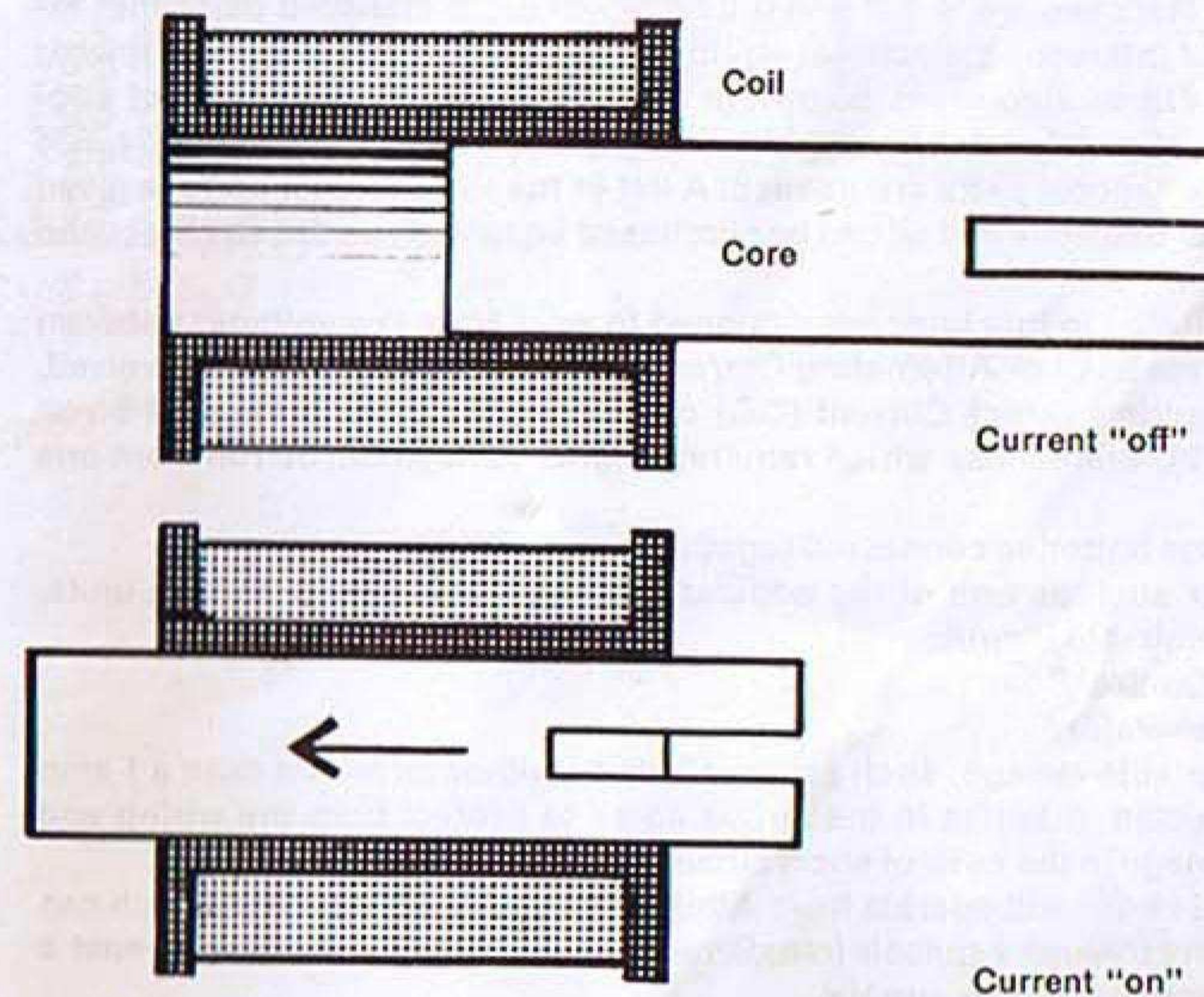

Fig. 3

Series and Parallel Wiring Circuits

An ordinary simple electrical circuit consists of a battery or other supply source, an 'on-off' switch and the apparatus to be operated, for example a lamp or a buzzer (Fig. 4). For the circuit to operate there must be no break in the connections between the various components which would interrupt the current flow.

There are two principal forms of wiring up the various elements of a circuit, which are known as 'series' and 'parallel' wiring respectively. The series system of wiring is shown in Fig. 4. In 'series' wiring the various elements in the circuit, i.e. battery, switch and model are connected up one after the other like the links of a chain, which will be clear from Fig. 5.

In 'parallel' wiring on the other hand each element is connected across the two leads from the battery or other power source (see Fig. 6).

List of Models operated by 4.5 volt battery

Of the models shown in this book the following can be operated from a 4.5 volt battery:

Model No.	E5	Model No.	E20	Model No.	E30
"	"	E7	"	"	E32
"	"	E8	"	"	E33
"	"	E9	"	"	E34
"	"	E11	"	"	E36
"	"	E14	"	"	

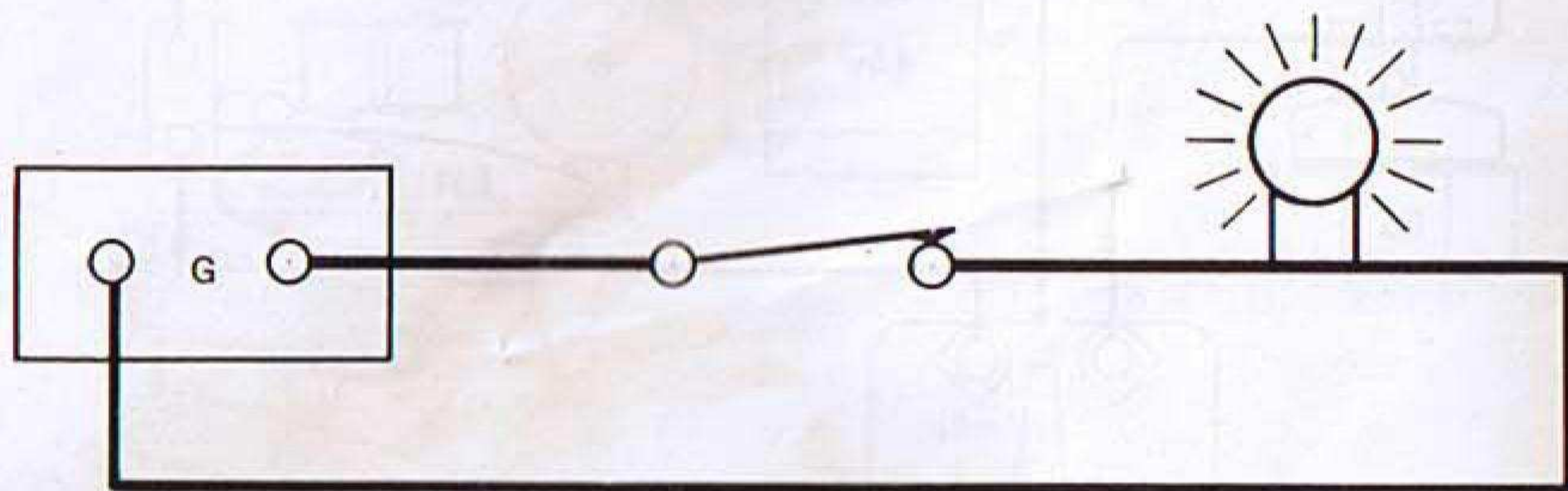
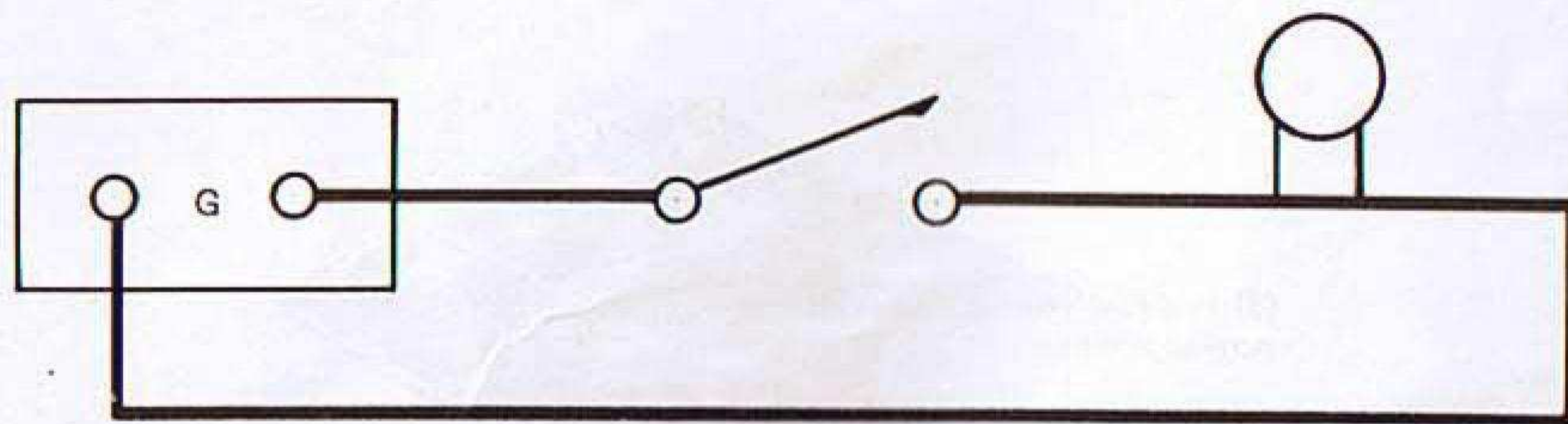

Fig. 4

Glossary of Basic Electrical Terms

An understanding of basic electrical terms listed below will enable you to obtain the greatest pleasure and interest from your 4EL Set.

Ampere :

Ampere is the unit by which the rate of flow of an electrical current is measured. The term is sometimes abbreviated to AMP.

Volt :

is the term used for measuring electrical force or pressure. If you imagine a flow of electrical current as being something like water flowing out of a tap, the term volt can be likened to the pressure behind the water, while the quantity of water passing through the tap can be likened to the term AMPERE.

Ohm :

The resistance offered by a wire to the flow of current can be likened to the resistance of a pipe to the flow of water. Ohm is the unit of electrical resistance (resistance to the flow of an electrical current through a conductor).

In electrical circuits a pressure of 1 volt is required to overcome resistance of 1 ohm in order that 1 ampere of current may flow.

Materials possess the property to conduct the flow of electricity through them to a greater, or lesser degree. Those materials that offer little resistance, for example copper and silver

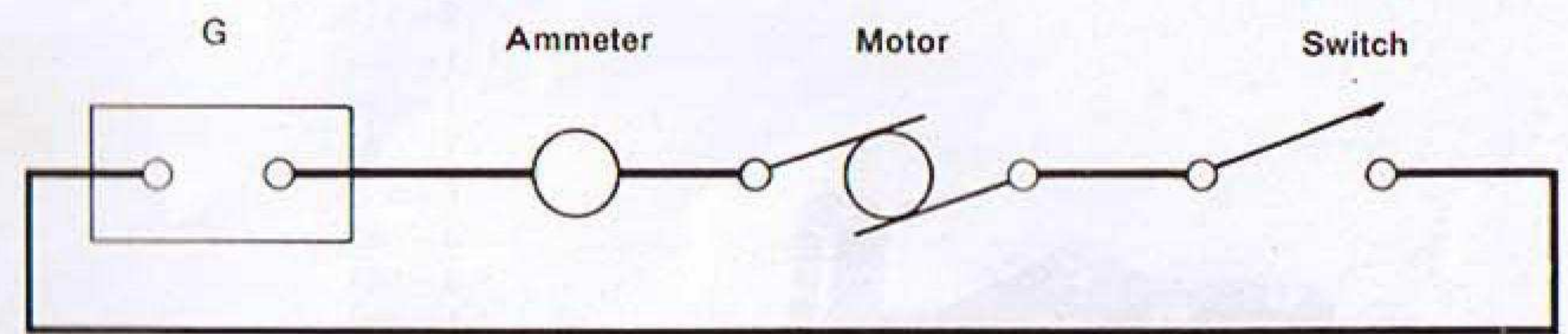

Fig. 5

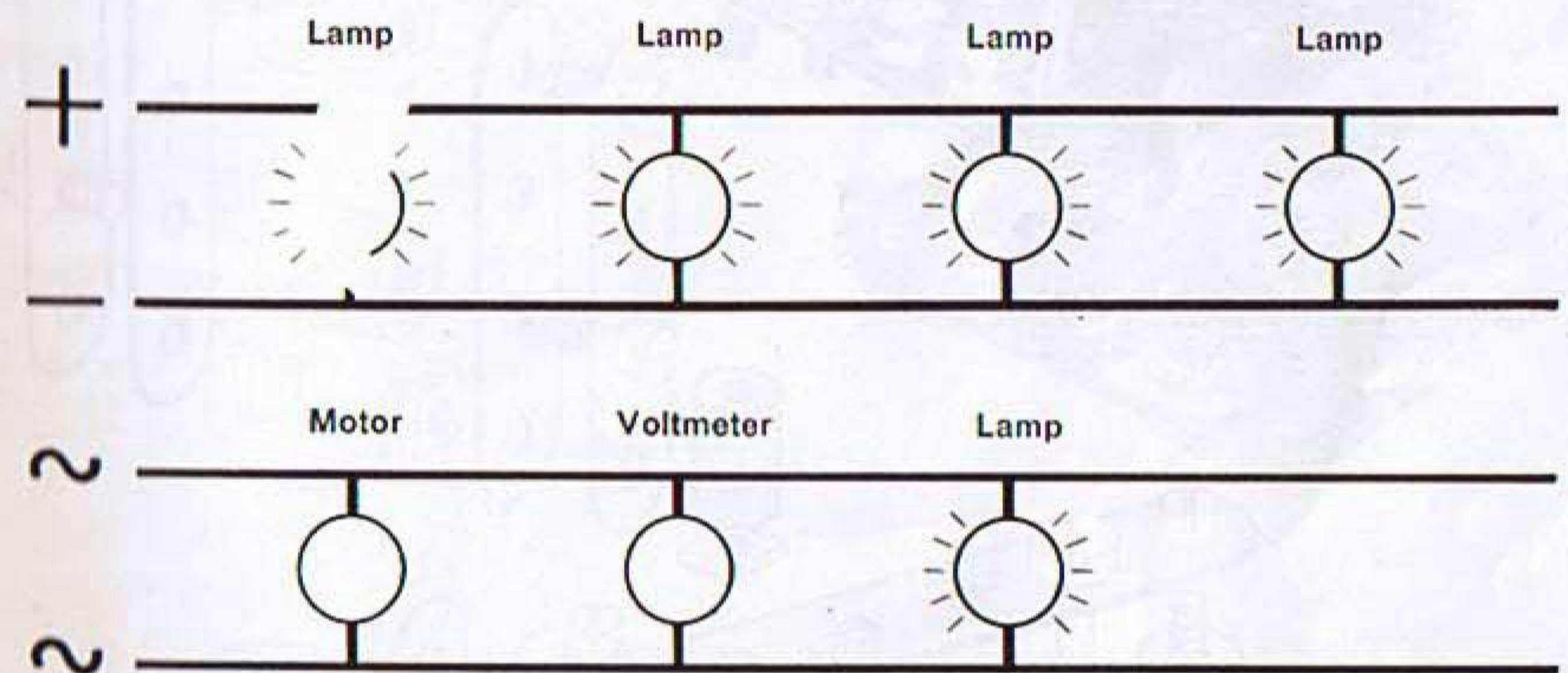

Fig. 6

are known as good CONDUCTORS. Other metals, such as iron and steel whilst still able to conduct current, do so less readily than copper. For instance, steel has approximately six times the resistance of copper.

Sometimes it is necessary to use materials which are deliberately chosen for their high resistance to current flow, and these are called resistances. They are generally alloys: an alloy of copper and nickel has a specific resistance about twenty-eight times that of copper. Non-metallic materials generally are very bad conductors of electricity. They may have specific resistances of many millions of ohms (1 million ohms = 1 megohm) and they are then called INSULATORS. Rubber, plastics, glass, paper and wood are examples of this kind of material.

Watt :

The unit for measuring the electrical energy which is produced or consumed is the watt, which is the product of the voltage and the amperage of the circuit, i.e. $V \times A = W$.

The models shown in this book represent only a few of the many ways in which the electrical parts can be used with your ordinary Meccano Set. After you have built these models you will have gained experience and will be able to devise other models for yourself.

E1 2-Way Switch

A single pole two-way switch with an 'off' position.
Never use more than 15 to 20v AC or DC.

- 2 - 10
- 2 - 12
- 12 - 37a
- 11 - 38
- 4 - 111a
- 2 - 111c
- 1 - 502
- 1 - 511
- 1 - 529
- 1 - 533
- 3 - 542
- 3 - 544
- 1 - 564

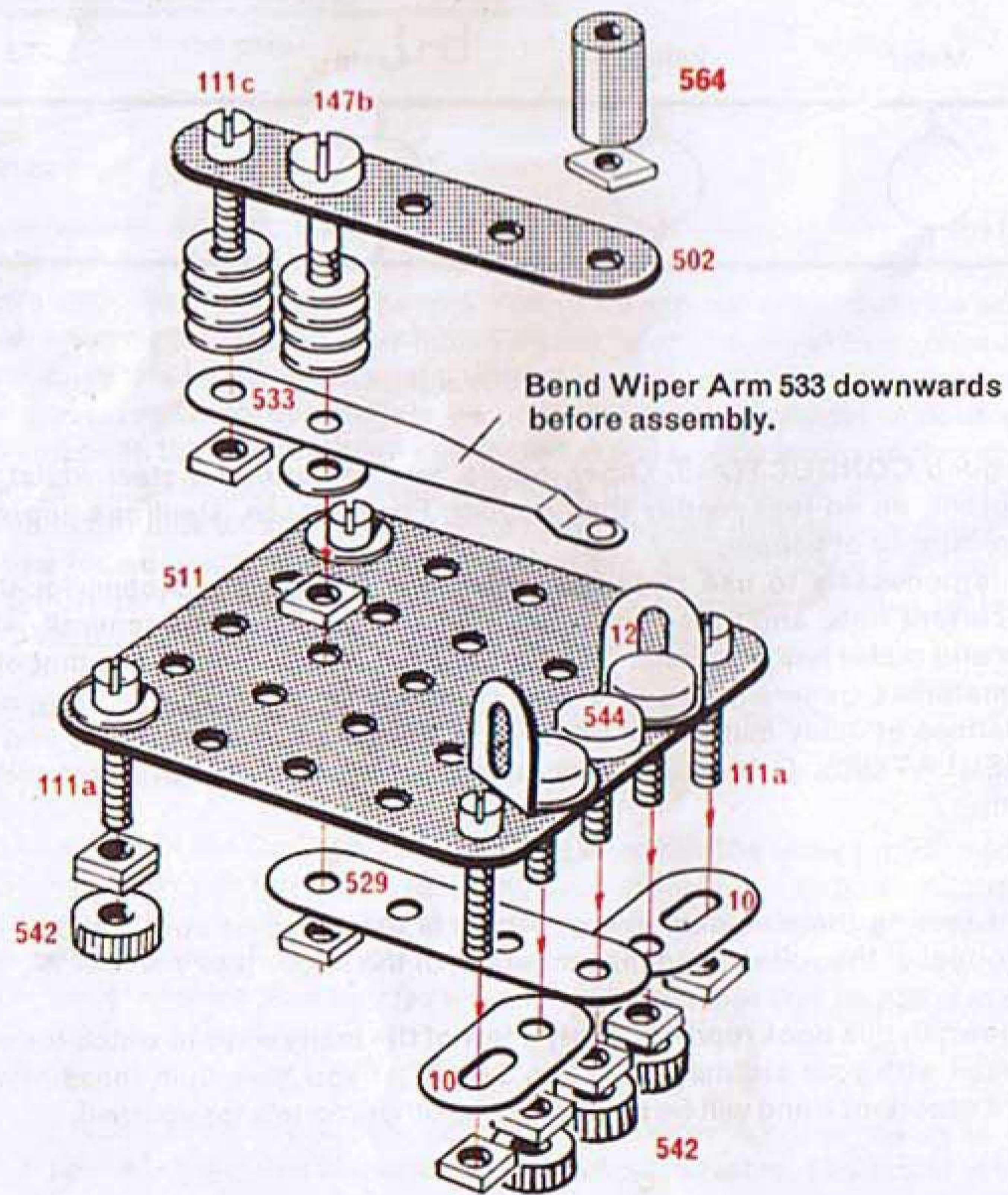
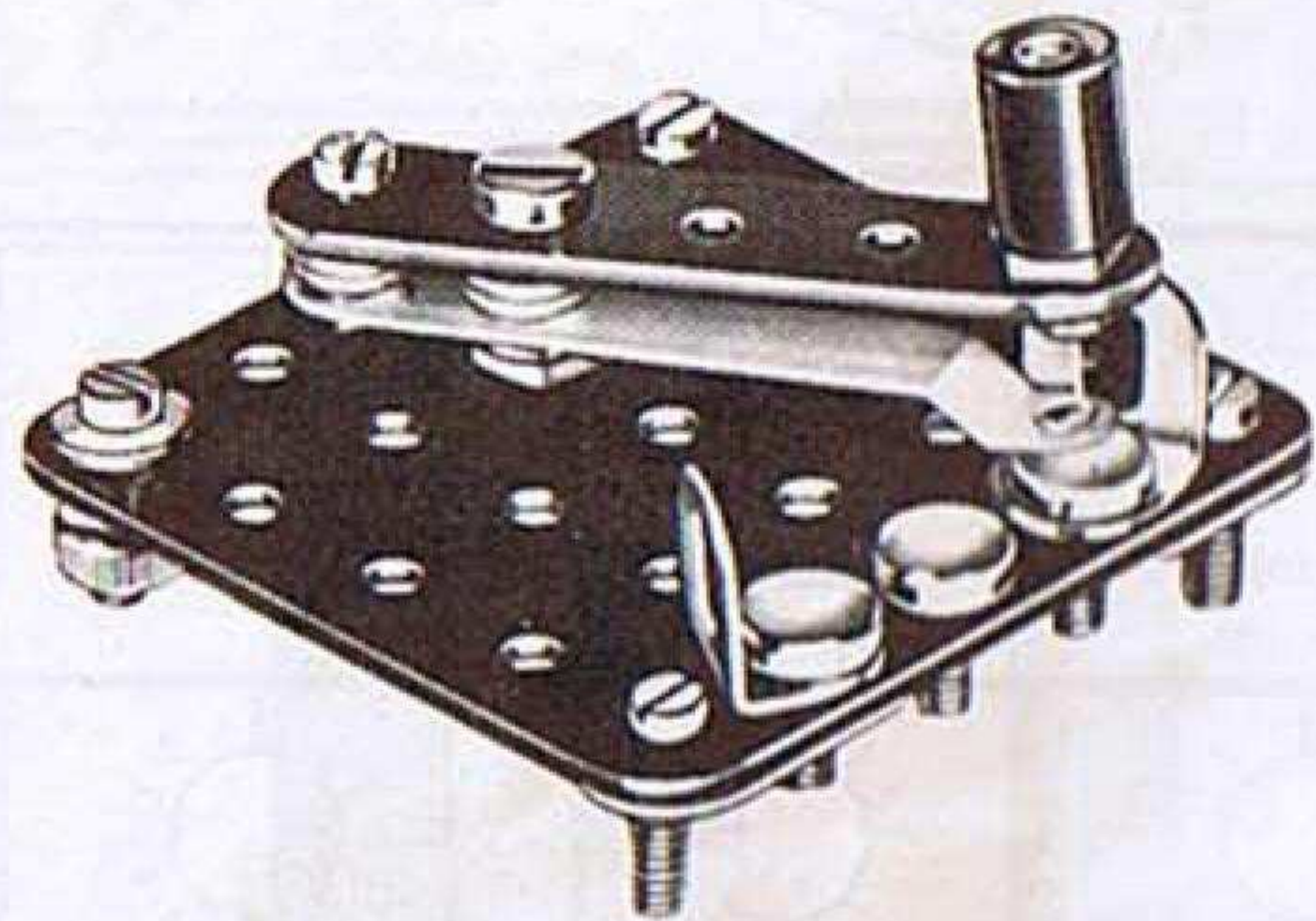

Some of the uses for a two-way switch

- (1) As a switch between a power supply and an appliance.
- (2) As a switch between an appliance and either of two alternative power supplies.

- (3) For controlling either of two appliances from the same power supply.

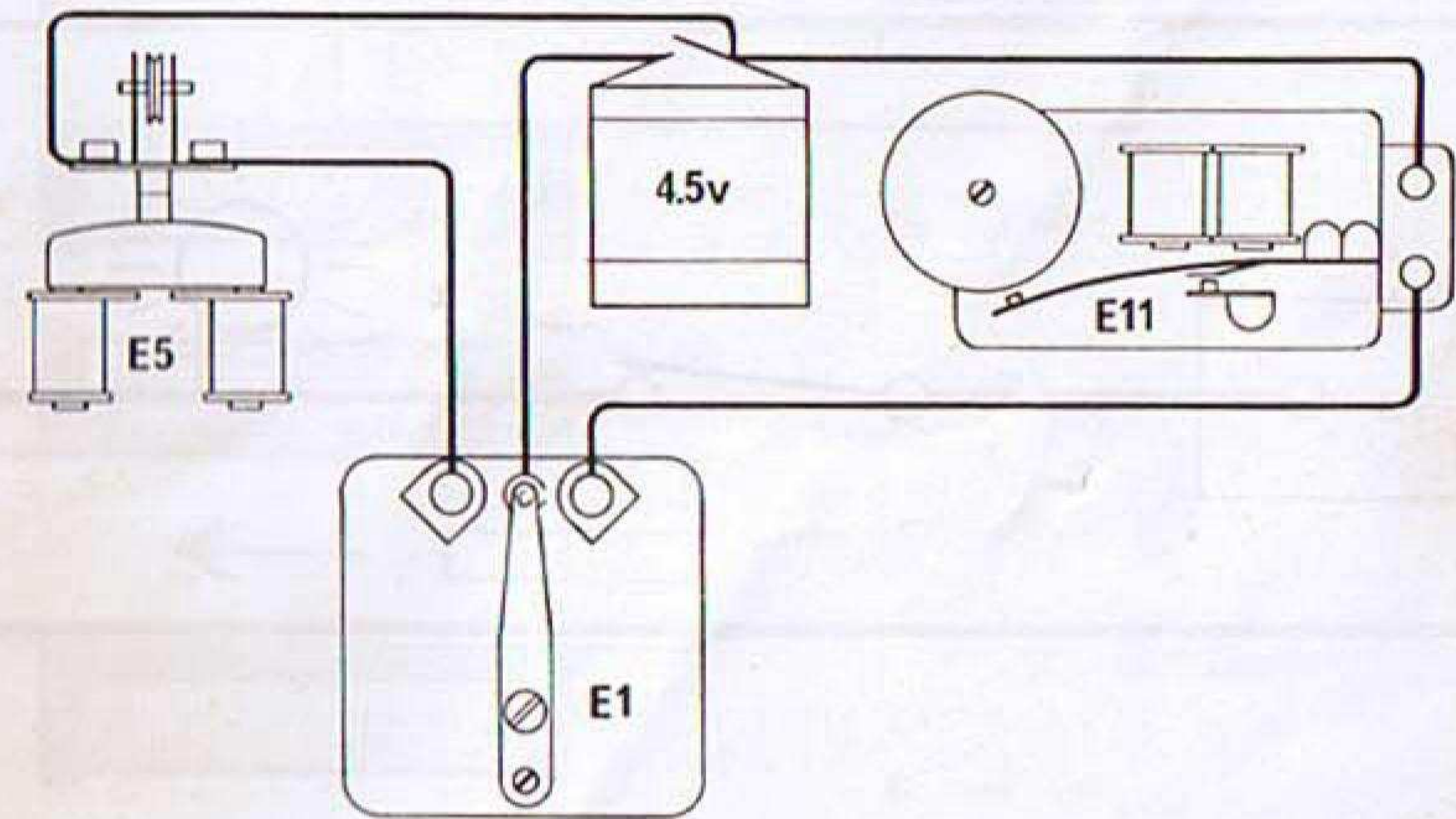

- (4) For controlling either of two separate circuits each consisting of a power supply and an appliance.

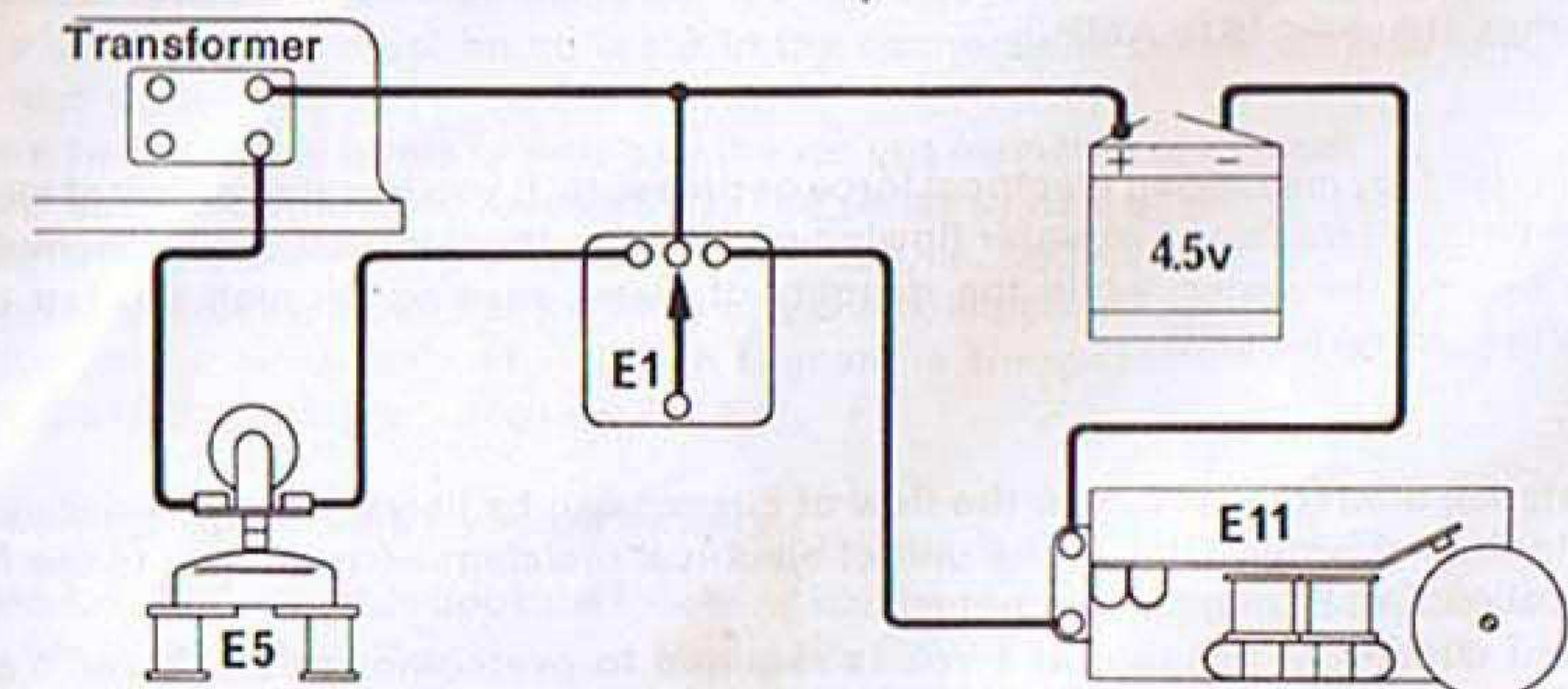

E2 Twin Push-Button Switch

A switch for push-button control of an appliance such as a doorbell.

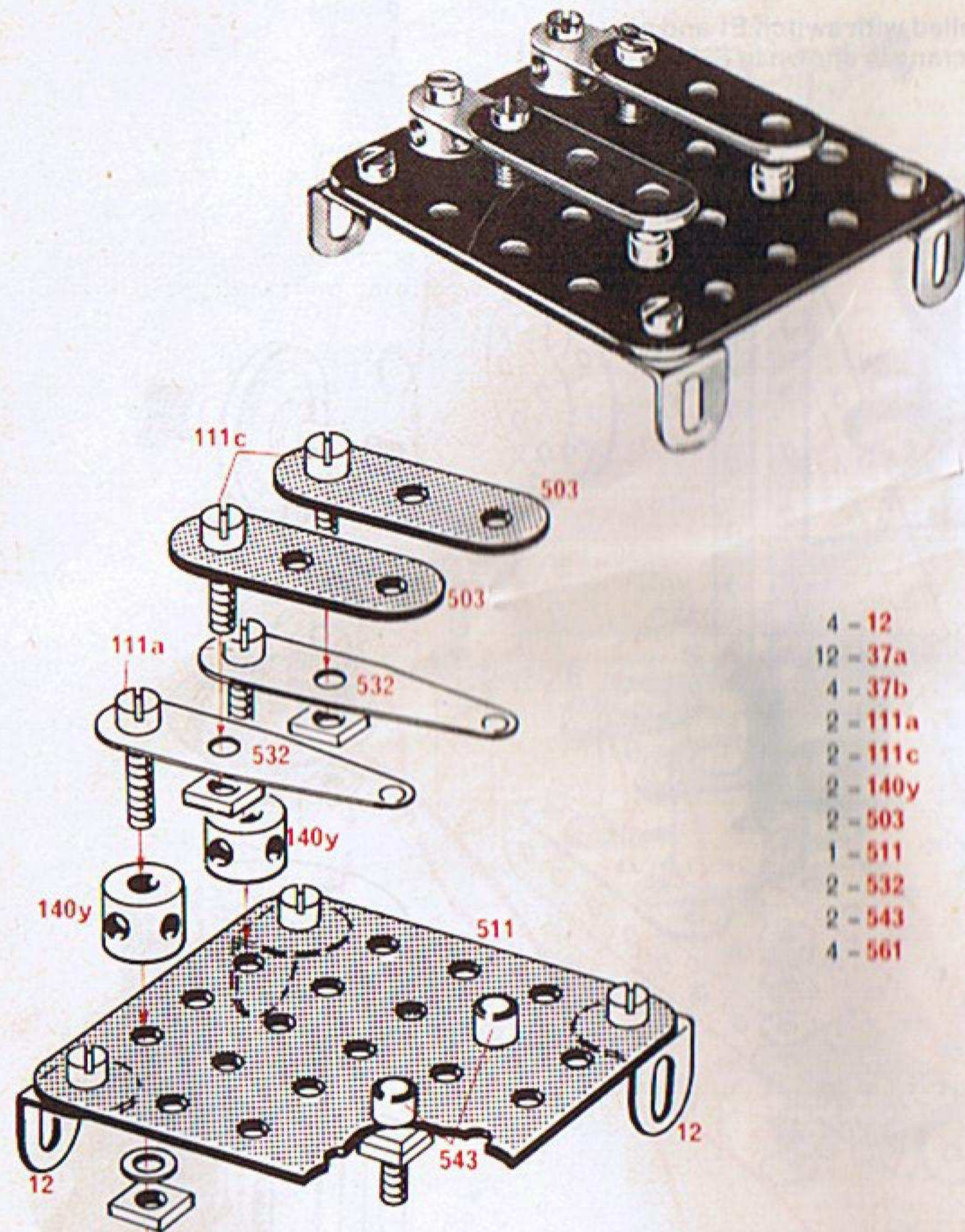

- 4 - 12
- 12 - 37a
- 4 - 37b
- 2 - 111a
- 2 - 111c
- 2 - 140y
- 2 - 503
- 1 - 511
- 2 - 532
- 2 - 543
- 4 - 561

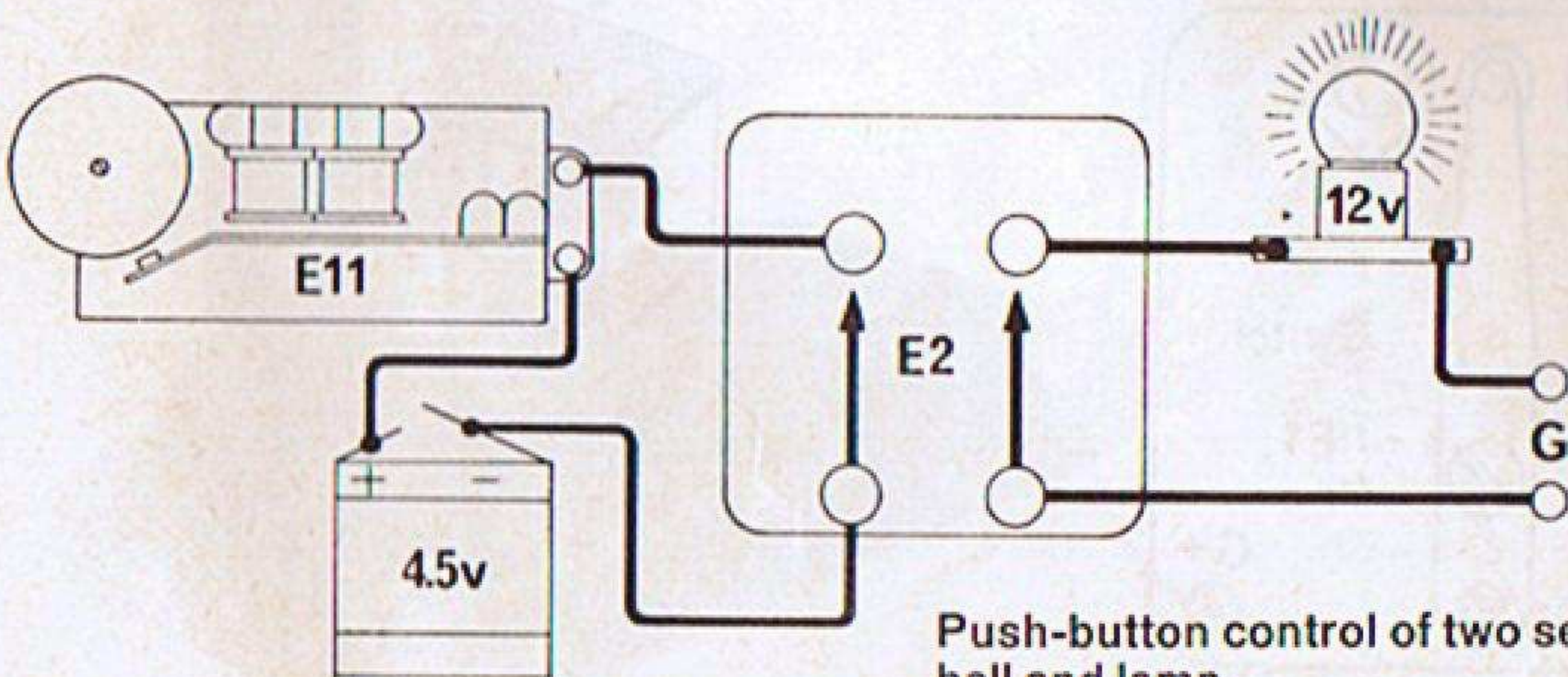

Push-button control of two separate circuits — electric bell and lamp.

E3 2-Pole Reversing Switch (Knife Switch)

This type of switch is frequently found on electrical switchboards. It is particularly useful in that it is able to reverse the polarity of a direct current supply source. For example it can be used for reversing a permanent magnet electric motor, such as model E21.

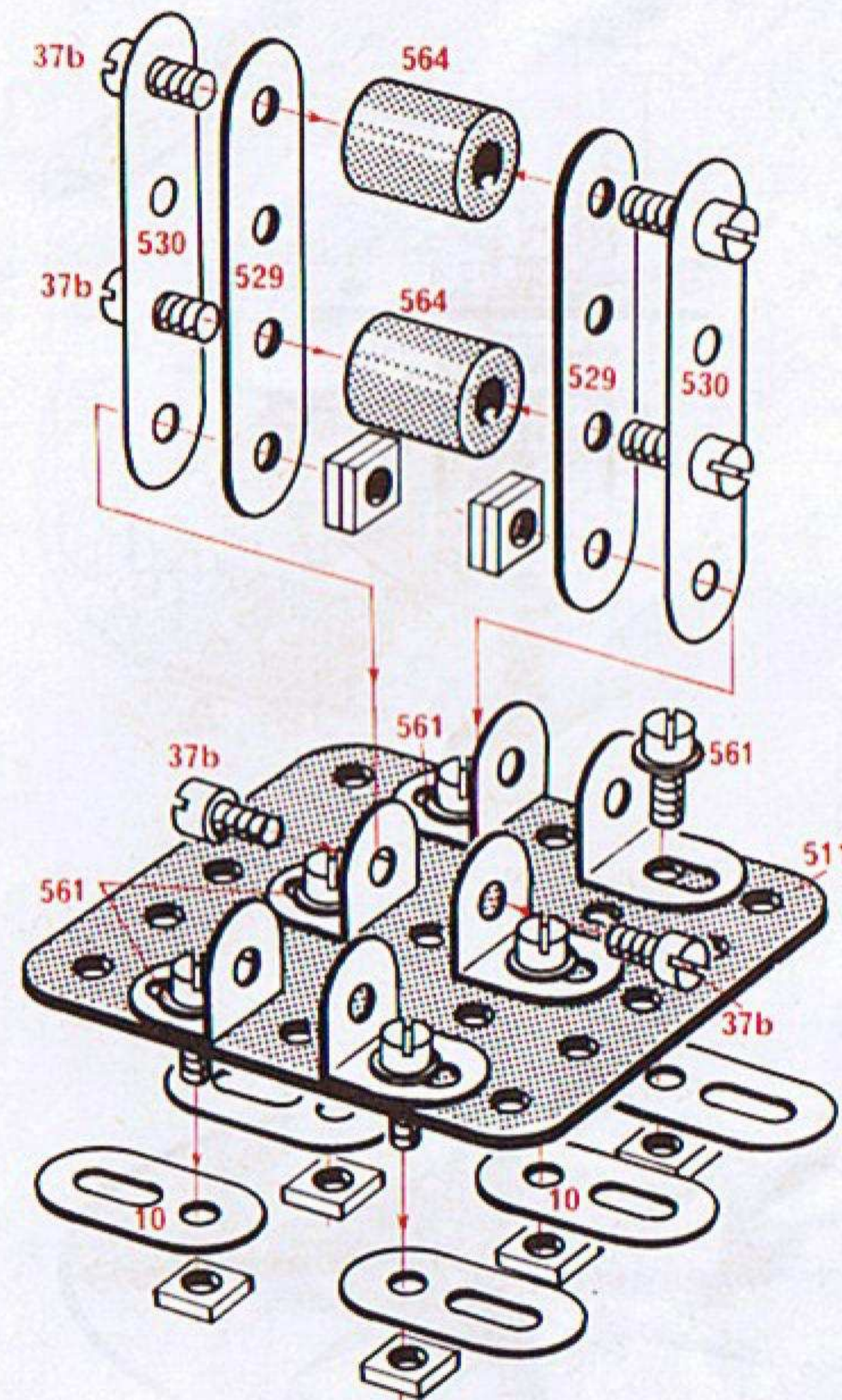

- 6 - 10
- 6 - 12
- 10 - 37a
- 12 - 37b
- 1 - 511
- 2 - 529
- 2 - 530
- 6 - 561
- 2 - 564

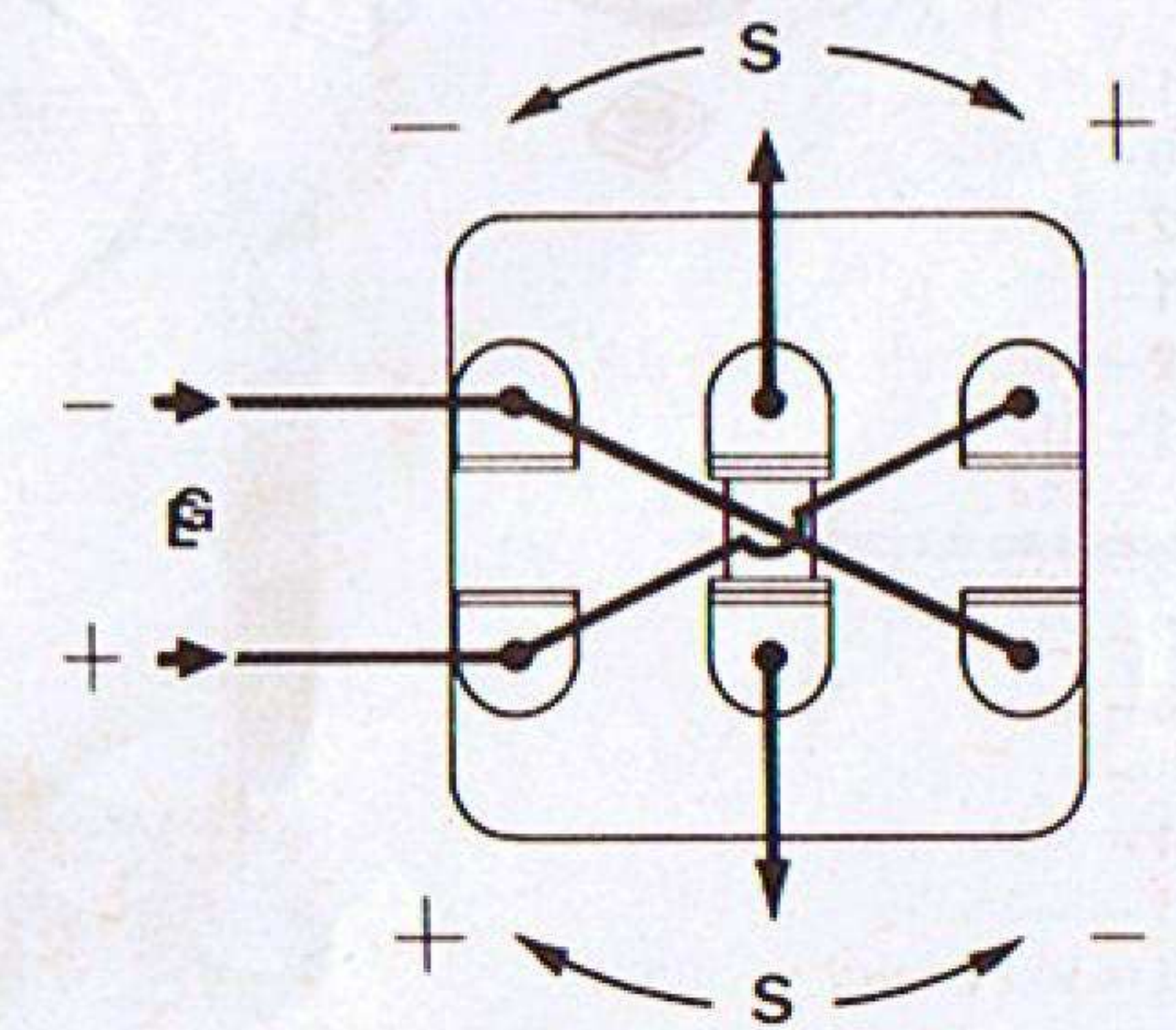
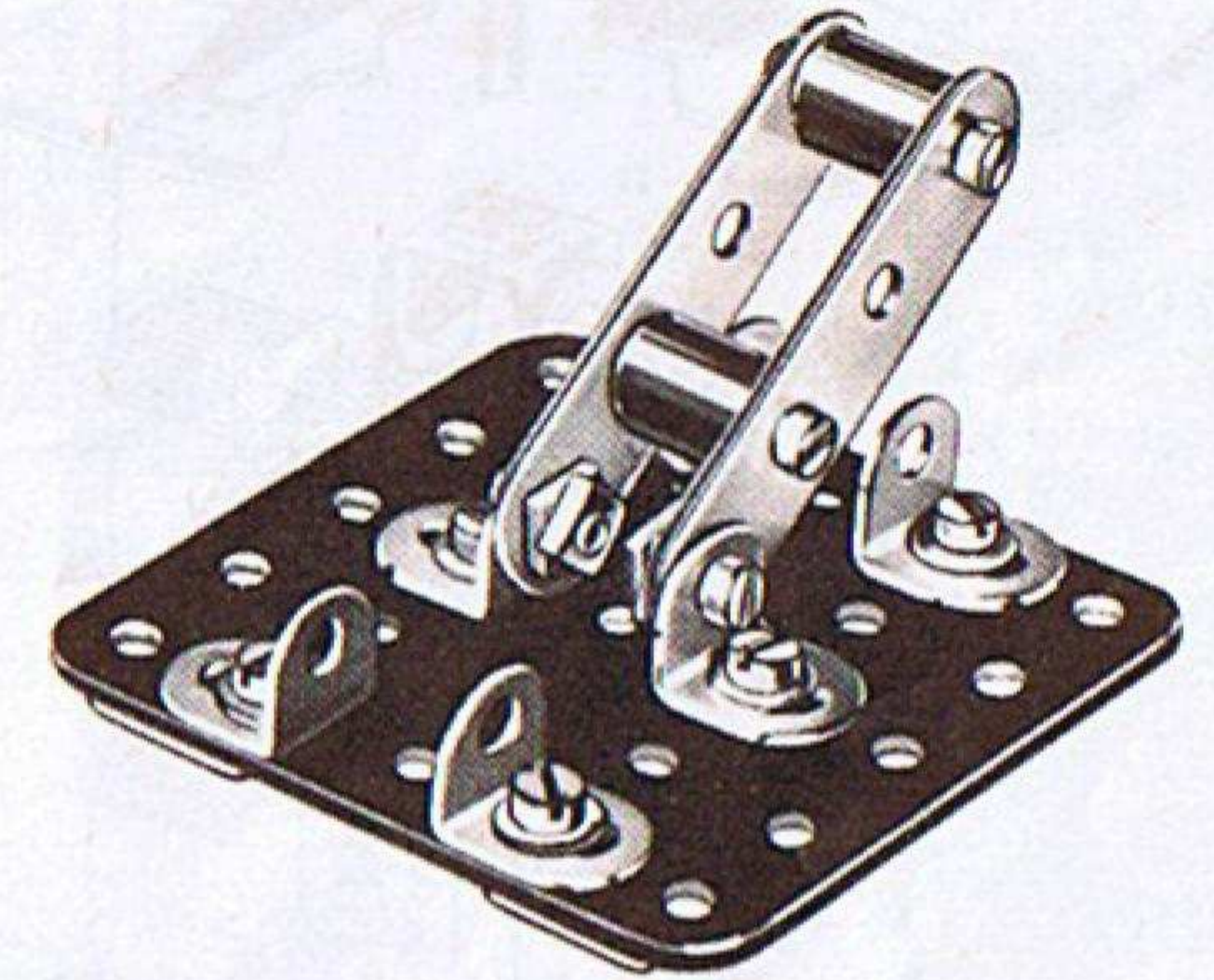

E4 Compass

This is a sensitive instrument which will be caused to deviate from its normal position if a magnet or steel object is brought near it.

Magnetic compasses, such as this, make use of the fact that a freely suspended permanent magnet always tends to align itself with the earth's magnetic field.

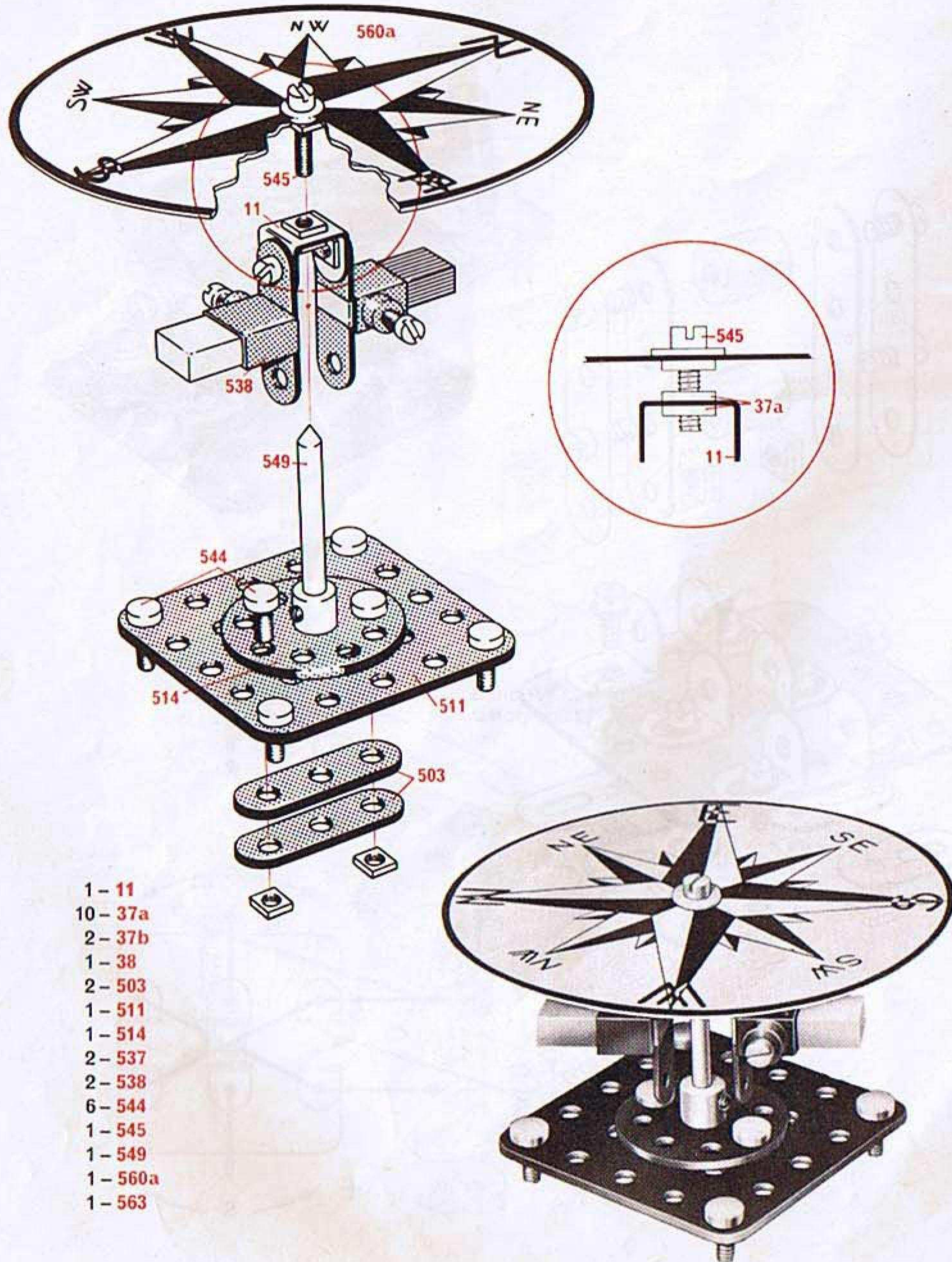

- 1 - 11
- 10 - 37a
- 2 - 37b
- 1 - 38
- 2 - 503
- 1 - 511
- 1 - 514
- 2 - 537
- 2 - 538
- 6 - 544
- 1 - 545
- 1 - 549
- 1 - 560a
- 1 - 563

E5 Electromagnetic Grab

An electromagnet of a type commonly used on cranes dealing with iron based metal.

4.5v battery.
6-15v AC or DC.

12v DC gives the best results but when using 12-15v DC avoid leaving the current on too long to prevent damage to the coils through overheating.

This model can be controlled with switch E1 and an example of its use with a crane is shown in E36.

- 2 - 12b
- 1 - 18b
- 1 - 22a
- 2 - 35
- 11 - 37a
- 2 - 37b
- 12 - 38
- 2 - 38d
- 1 - 59
- 1 - 111
- 4 - 111a
- 1 - 111d
- 1 - 514
- 2 - 520
- 2 - 525
- 2 - 526
- 2 - 542
- 4 - 561
- 1 - 562

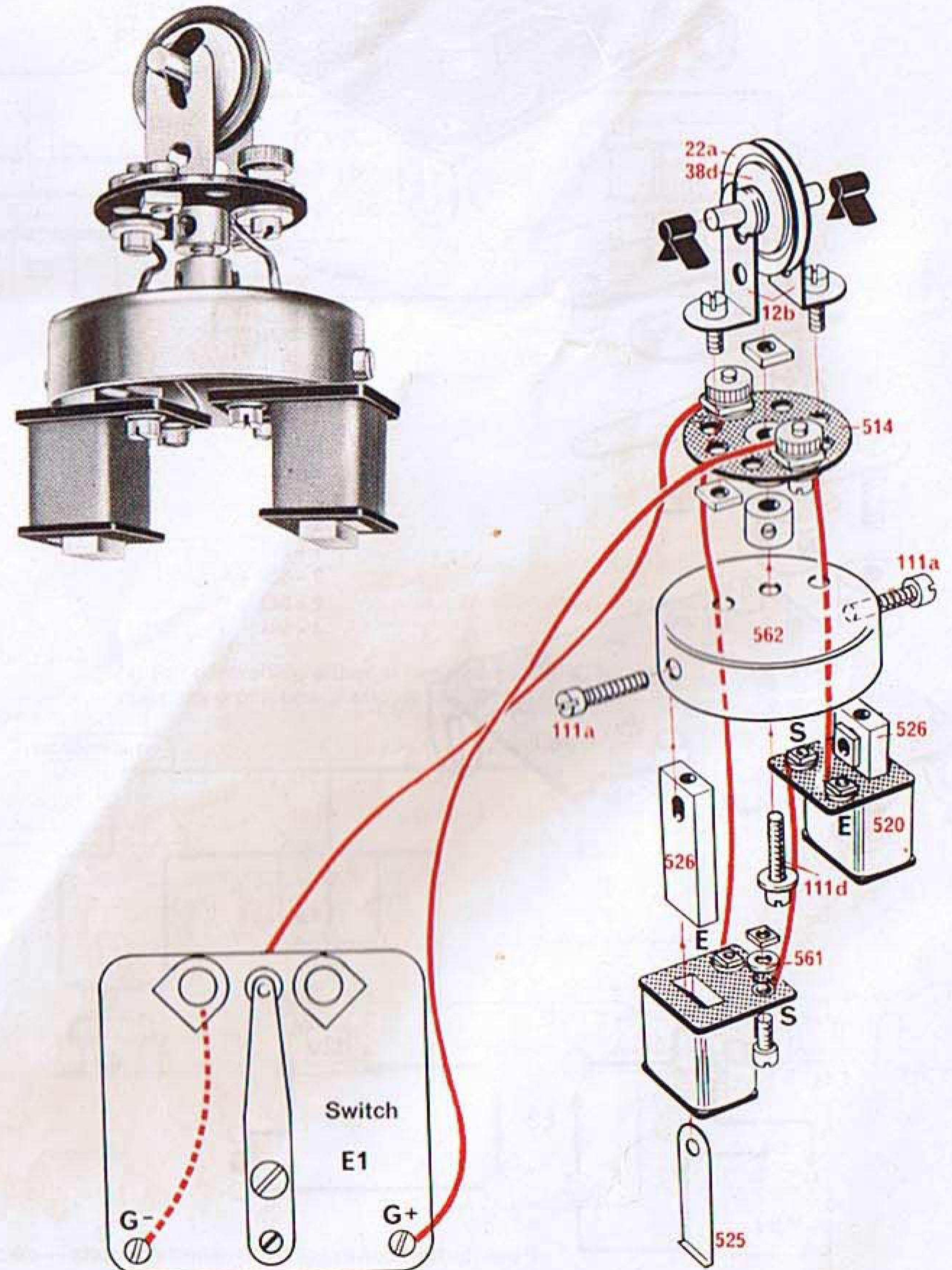

E6 Signal

A signal of a type used on continental railways. It can be used with 'O' gauge railways.

12v DC or 15v AC. A voltage of less than 12v does not give good results.

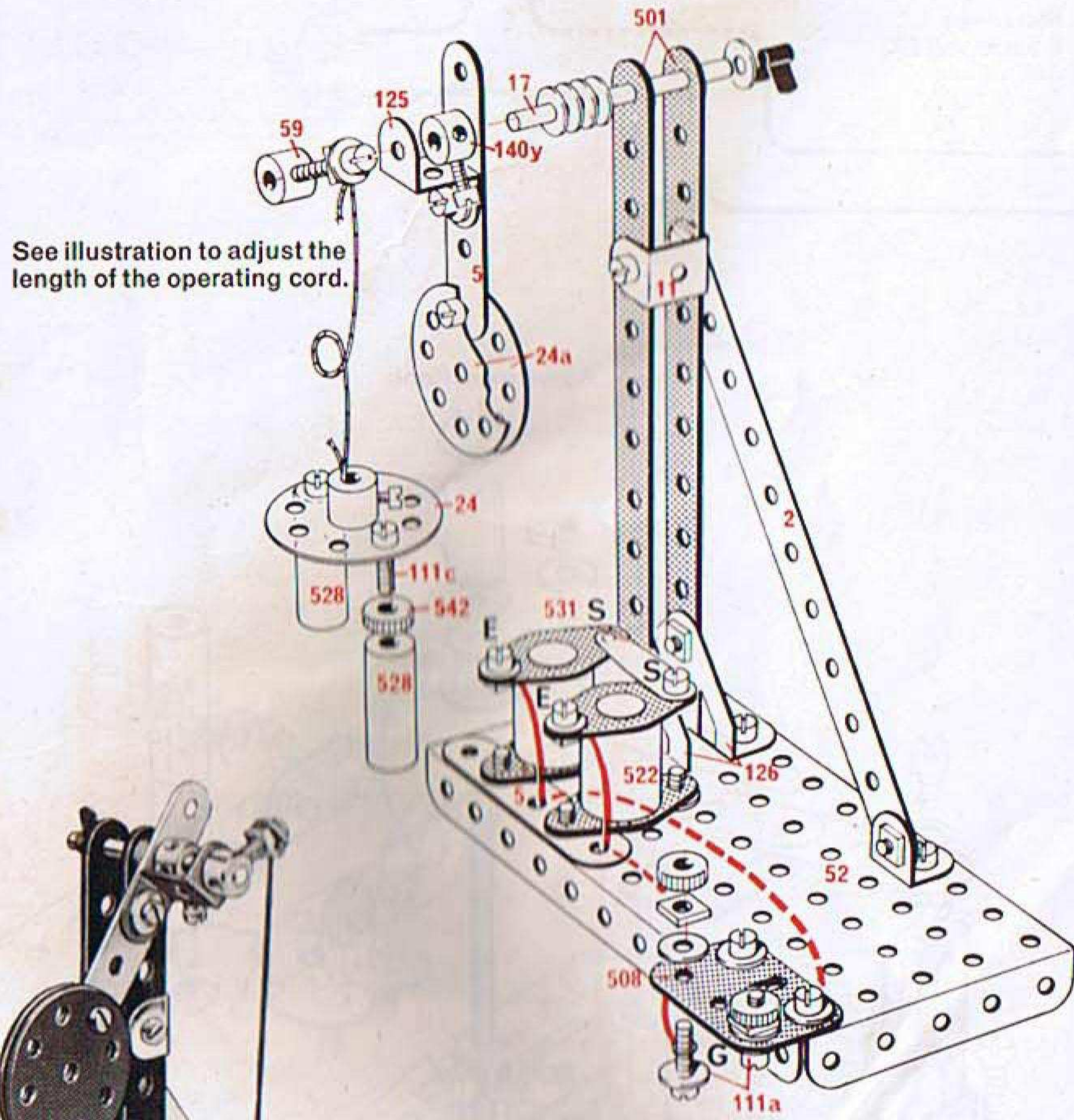

See illustration to adjust the length of the operating cord.

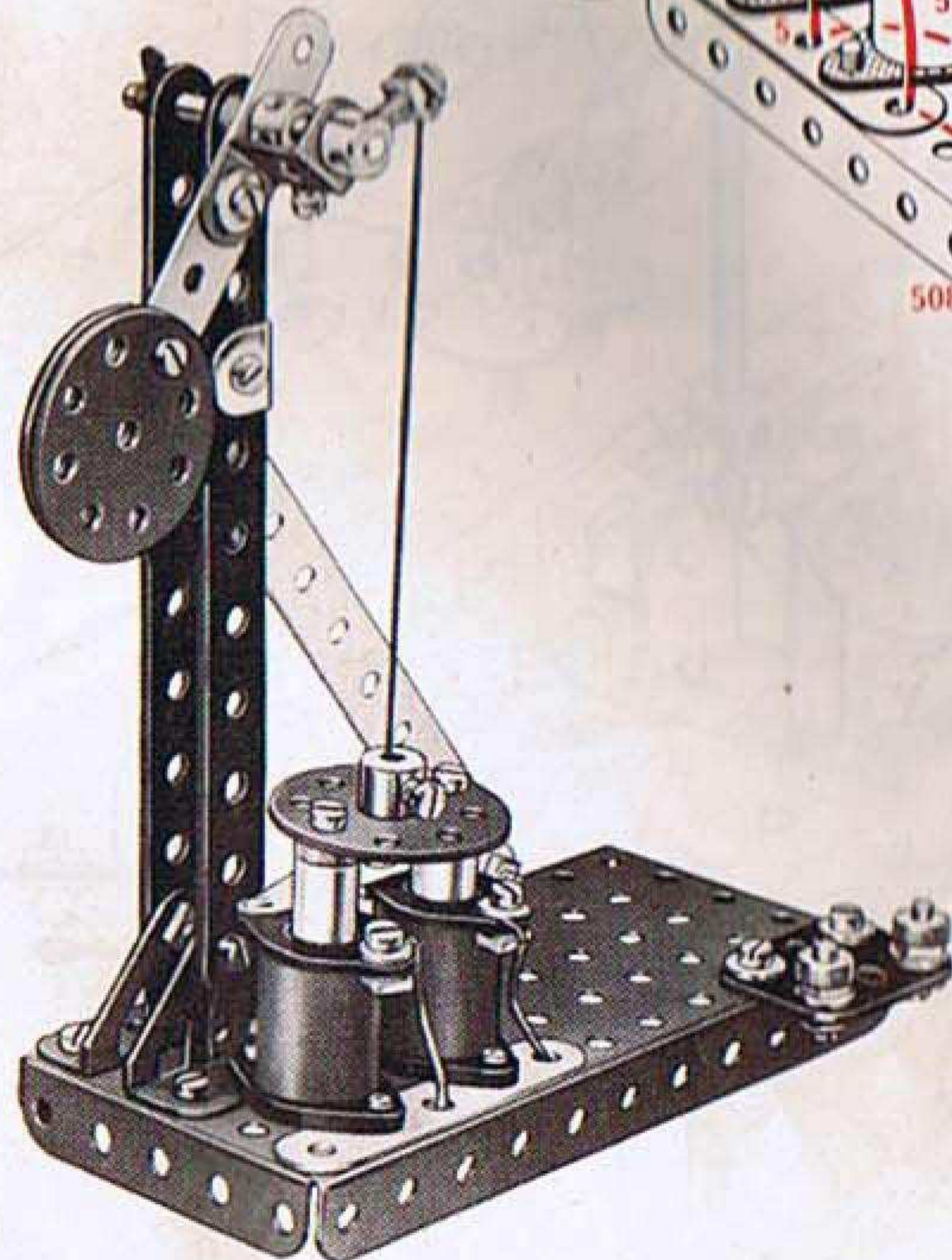

- | | |
|----------|----------|
| 1 - 2 | 3 - 111a |
| 2 - 5 | 2 - 111c |
| 1 - 11 | 1 - 125 |
| 1 - 12 | 2 - 126 |
| 1 - 17 | 1 - 140y |
| 1 - 24 | 2 - 501 |
| 2 - 24a | 1 - 508 |
| 1 - 35 | 2 - 522 |
| 21 - 37a | 2 - 528 |
| 23 - 37b | 1 - 531 |
| 15 - 38 | 4 - 542 |
| 1 - 52 | 2 - 561 |
| 1 - 59 | |

E7 4-Bladed Motor

A very simple but low-powered electric motor.
4.5v battery.
6v AC or DC.

The setting of the air-gaps must be carried out correctly and when connected up the motor must be started by spinning the rotor clockwise by hand.

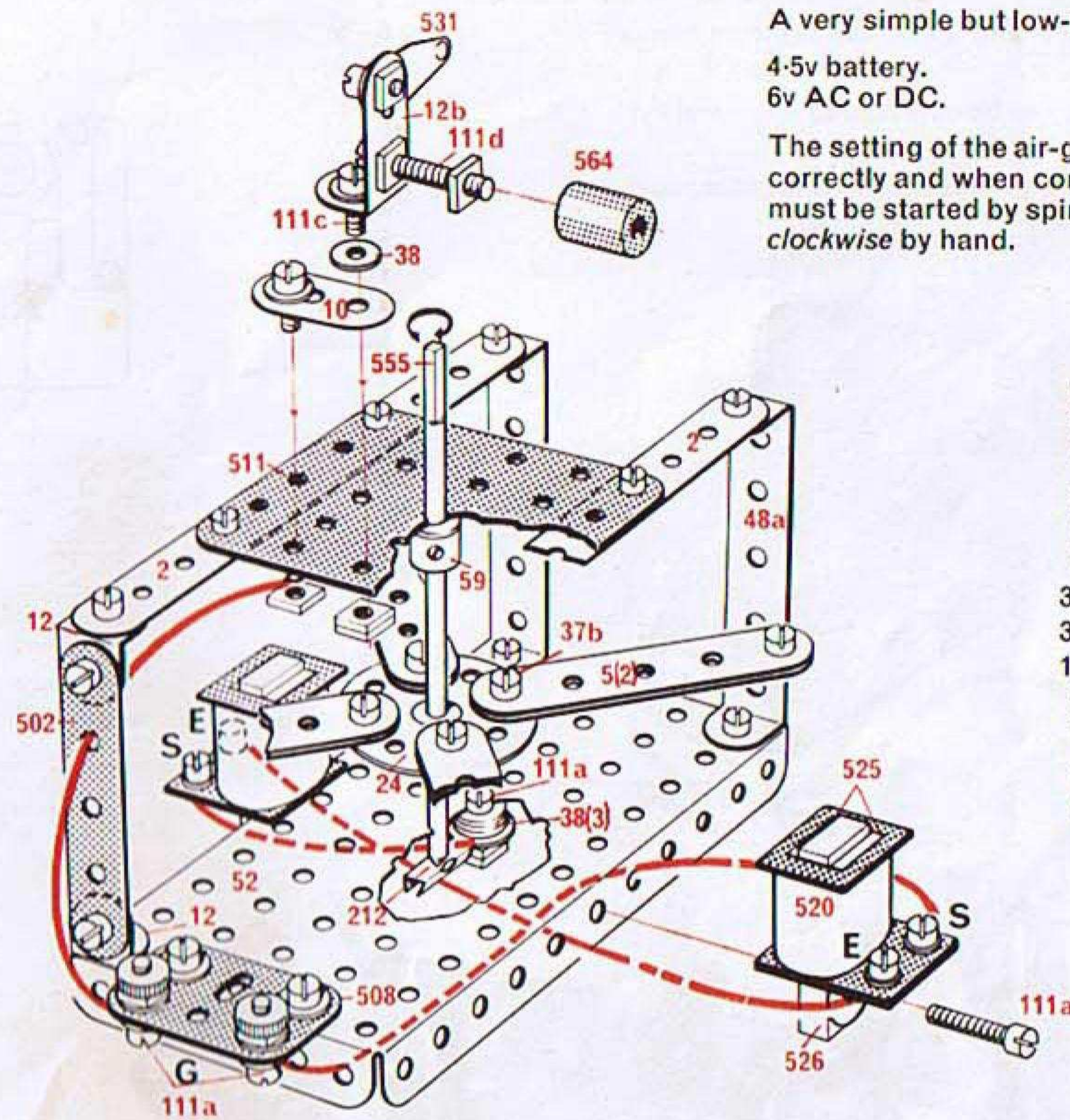

- | | |
|----------|----------|
| 2 - 2 | 2 - 111c |
| 8 - 5 | 1 - 111d |
| 1 - 10 | 1 - 212 |
| 4 - 12 | 1 - 502 |
| 1 - 12b | 1 - 508 |
| 1 - 24 | 1 - 511 |
| 35 - 37a | 2 - 520 |
| 32 - 37b | 4 - 525 |
| 18 - 38 | 2 - 526 |
| 2 - 48a | 1 - 531 |
| 1 - 52 | 2 - 542 |
| 1 - 59 | 1 - 555 |
| 4 - 111a | 1 - 564 |

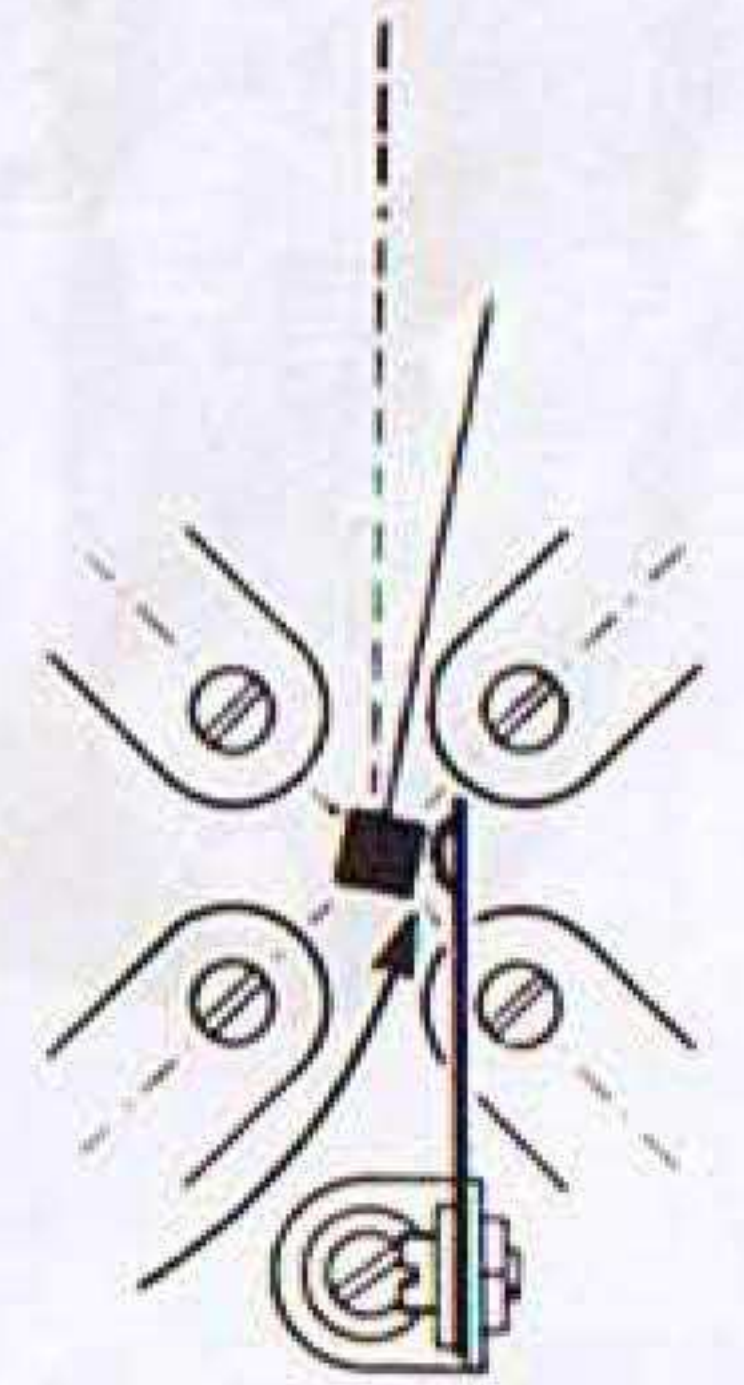
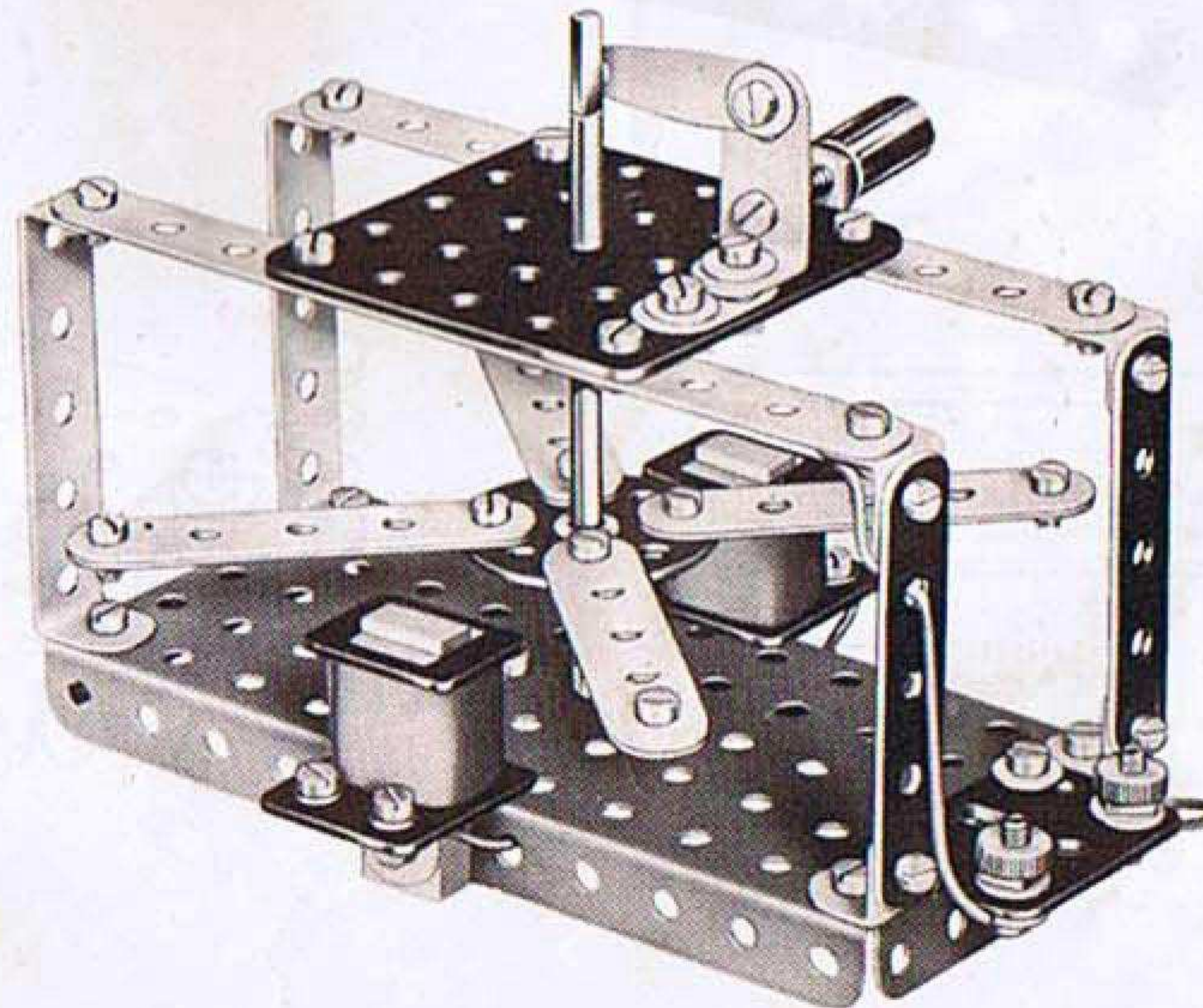

Air gap = thickness of part 532.

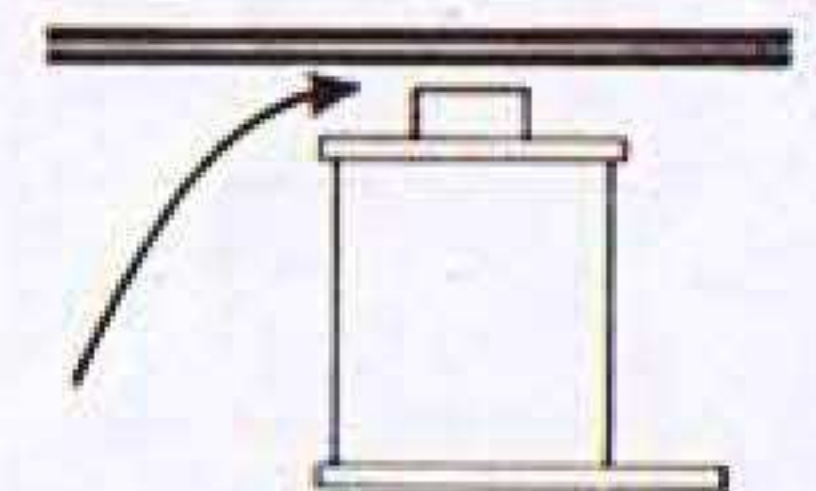

Air gap = thickness of Strip part 5.

E8 Buzzer

This buzzer can be used with the morse key from model E33.

The tone of the buzzer can be adjusted by means of the Insulating Spacer 564.

The contacts should be kept clean with fine glasspaper.

4.5v battery,
not more than 6v DC.

- 6 - 5
- 16 - 37a
- 10 - 37b
- 12 - 38
- 1 - 52
- 2 - 111a
- 5 - 111c
- 1 - 126a
- 1 - 502
- 1 - 508
- 1 - 520
- 2 - 525
- 2 - 526
- 2 - 528
- 1 - 529
- 2 - 532
- 1 - 538
- 2 - 542
- 1 - 543
- 5 - 561
- 2 - 563
- 1 - 564

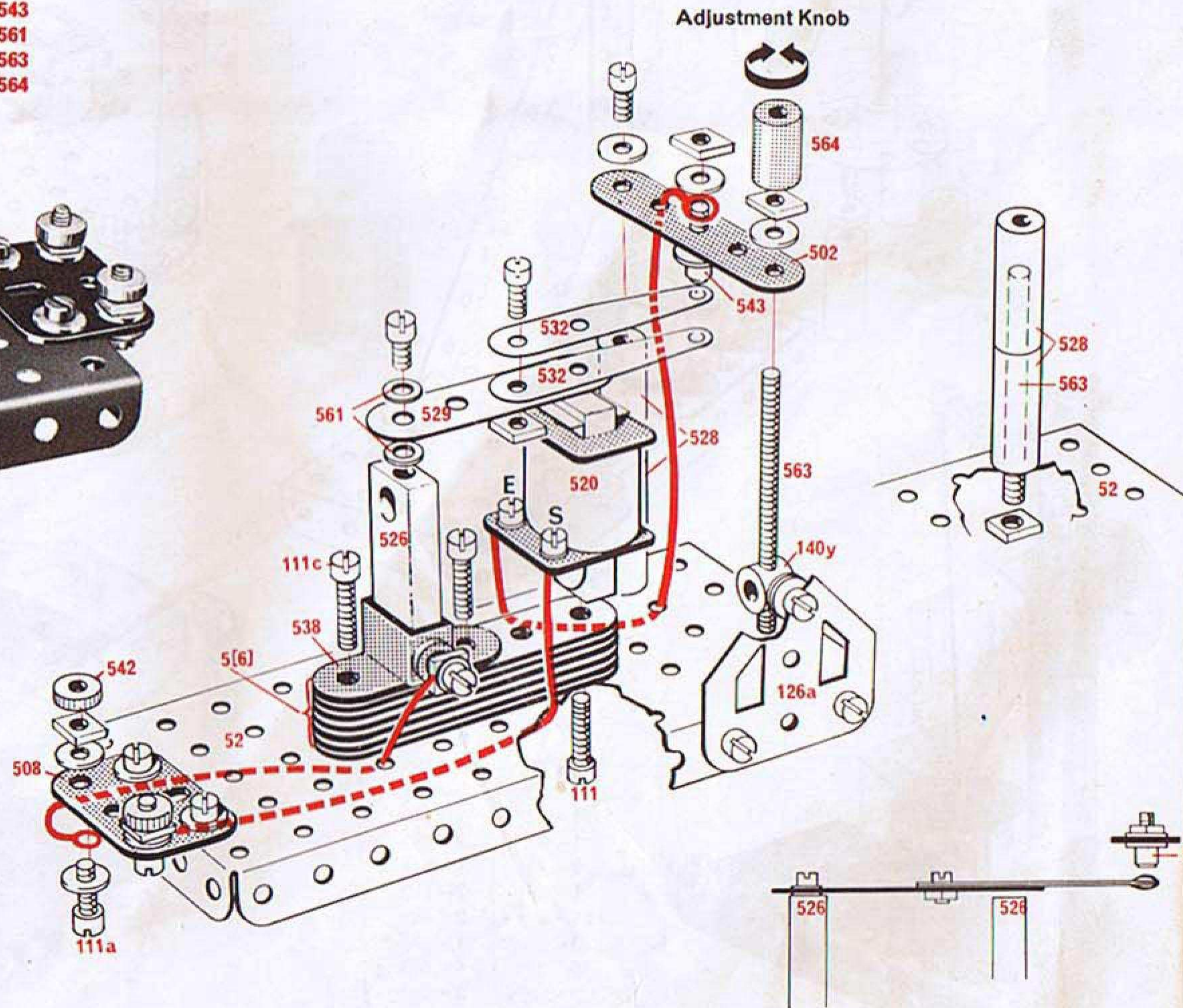
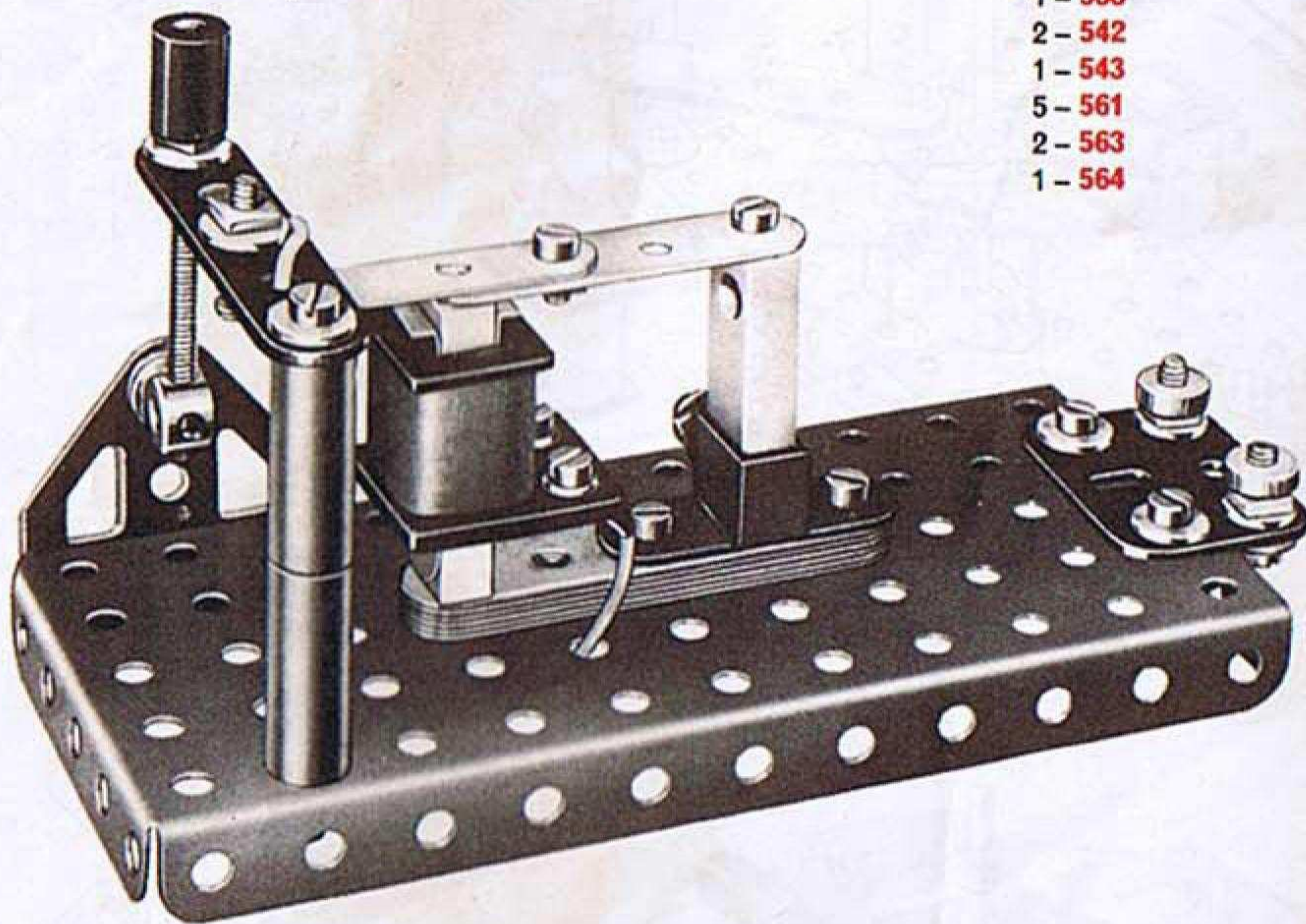
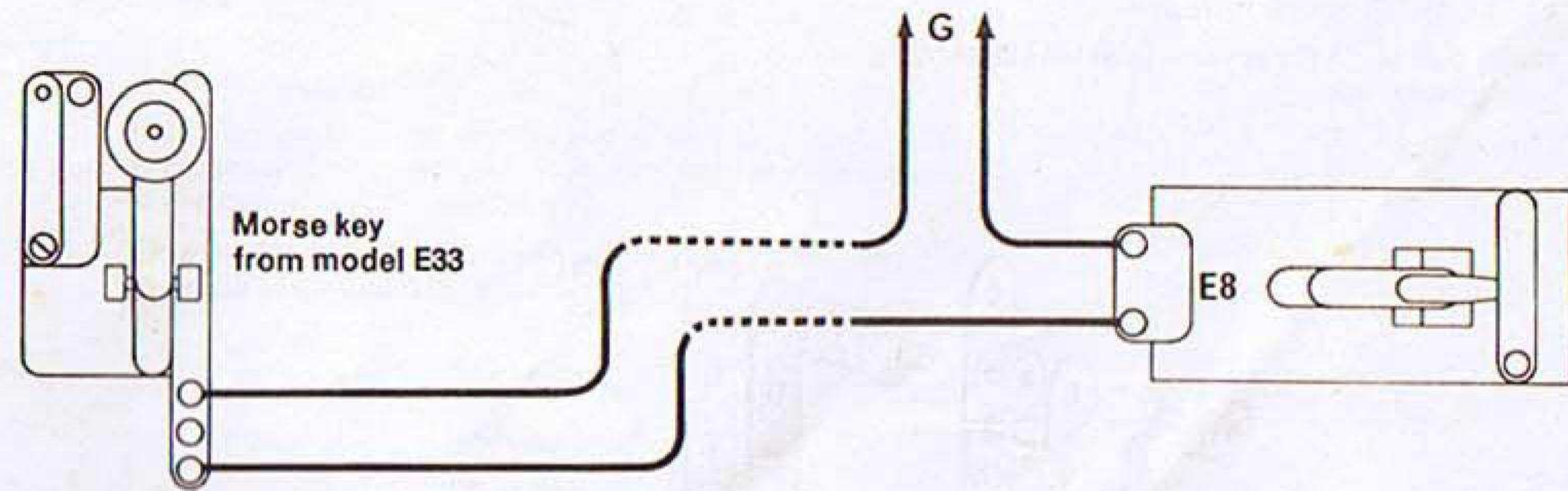

MORSE ALPHABET

A	· -	M	- -	Y	- · - -
B	- · · ·	N	- ·	Z	- - - -
C	- · - ·	O	- - -	1	- - - -
D	- · · ·	P	- · - ·	2	· - - -
E	· - · -	Q	- · - ·	3	· · - -
F	· - · -	R	- · - ·	4	· - · -
G	- · - ·	S	· · - ·	5	· · · ·
H	· · - ·	T	· - · -	6	- · · ·
I	· · - -	U	· · - -	7	- · - ·
J	- · - -	V	· - · -	8	- · - ·
K	- · · ·	W	- · - ·	9	- · - ·
L	· - · ·	X	- · · ·	0	- - - -

E9 Electric Shock Machine

The use of this apparatus is perfectly safe. If two, three or four people join hands, with those at each end holding one of the leads 534, a mild shock is felt by everyone in the chain.

This model incorporates the primary coil and contact breaker of the famous Ruhmkorff induction coil which induces a current of very low amperage and greatly increased voltage.

Operate from 4.5v battery only.

A higher voltage than 4.5v DC gives an unpleasantly strong shock and should not be exceeded.

- 7 - 5
- 3 - 12
- 30 - 37a
- 21 - 37b
- 19 - 38
- 1 - 52
- 2 - 111
- 4 - 111a
- 1 - 507
- 1 - 508
- 1 - 513
- 2 - 520
- 4 - 525
- 2 - 526
- 2 - 529
- 1 - 530
- 1 - 531
- 2 - 534
- 4 - 542
- 1 - 543
- 6 - 561
- 1 - 564

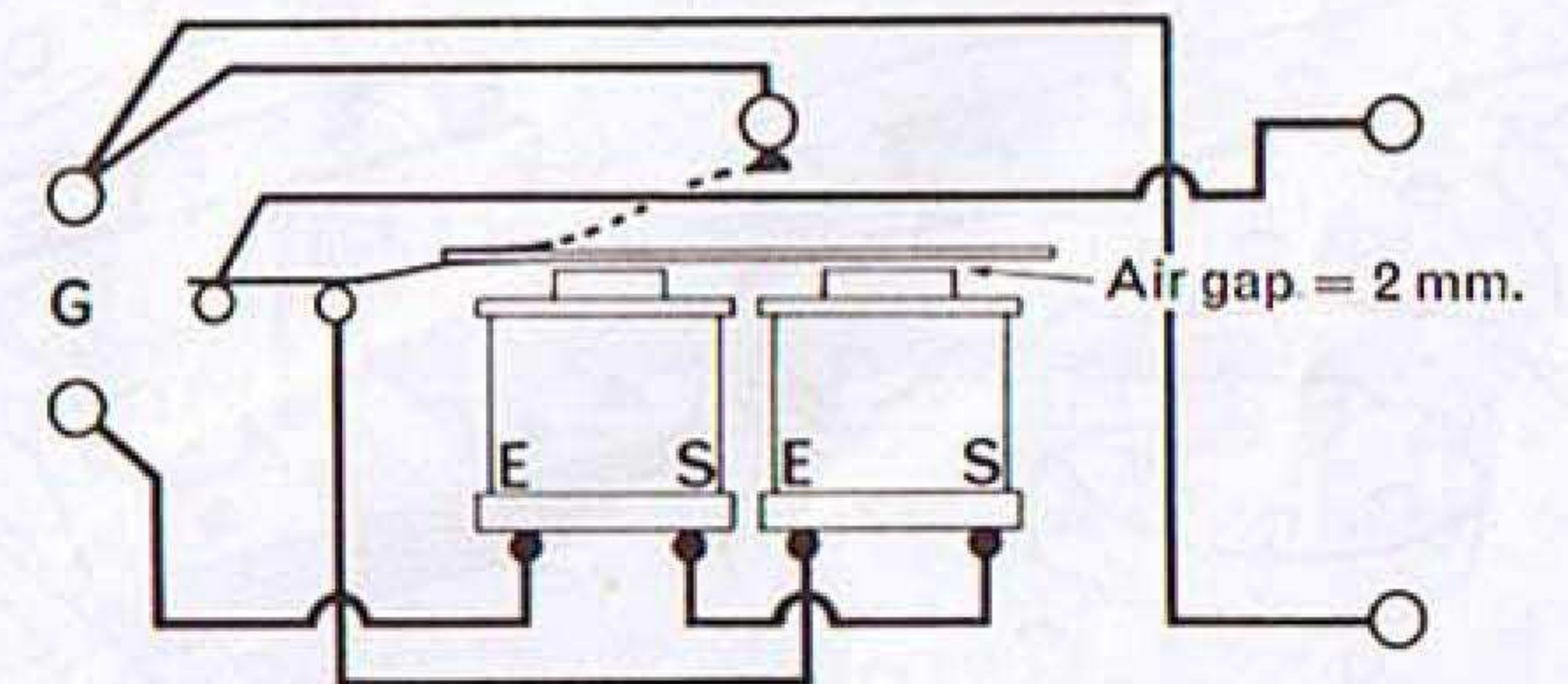
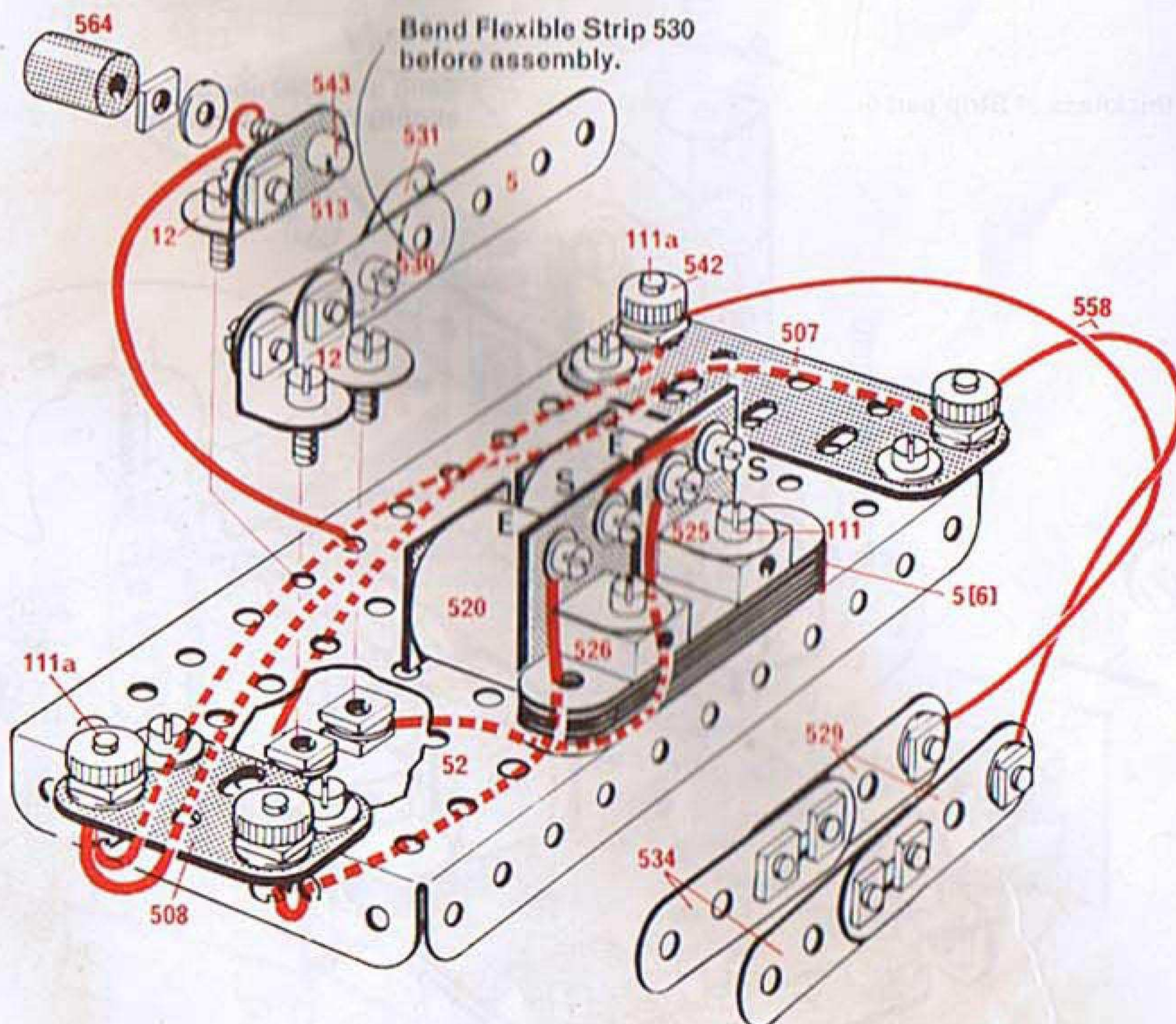
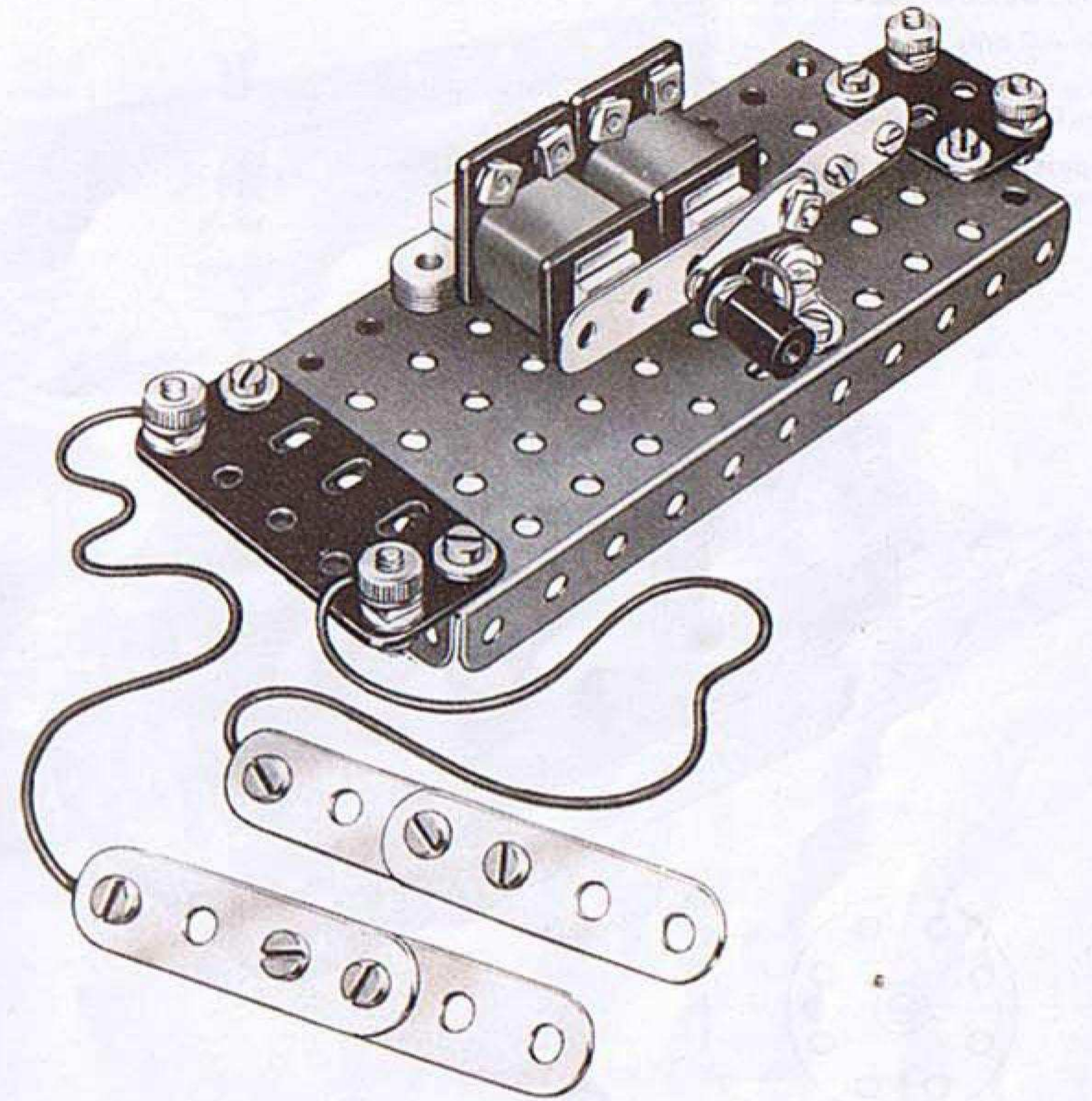

E10 Vibratory Motor

Motors working on this principle are used for operating shop window models and displays.

15v AC only.

The rubber band on the end of the arm vibrates against the Pulley Wheel and causes it to rotate.

Adjust the rubber band by trial and error to obtain the maximum speed.

- 1 - 2
- 7 - 5
- 1 - 10
- 3 - 12
- 1 - 19b
- 1 - 24a
- 26 - 37a
- 20 - 37b
- 18 - 38
- 1 - 48a
- 1 - 52
- 2 - 111
- 2 - 111a
- 3 - 111c
- 2 - 126a
- 1 - 186
- 1 - 212
- 1 - 501
- 1 - 508
- 2 - 520
- 2 - 525
- 2 - 526
- 1 - 530
- 1 - 549
- 4 - 561

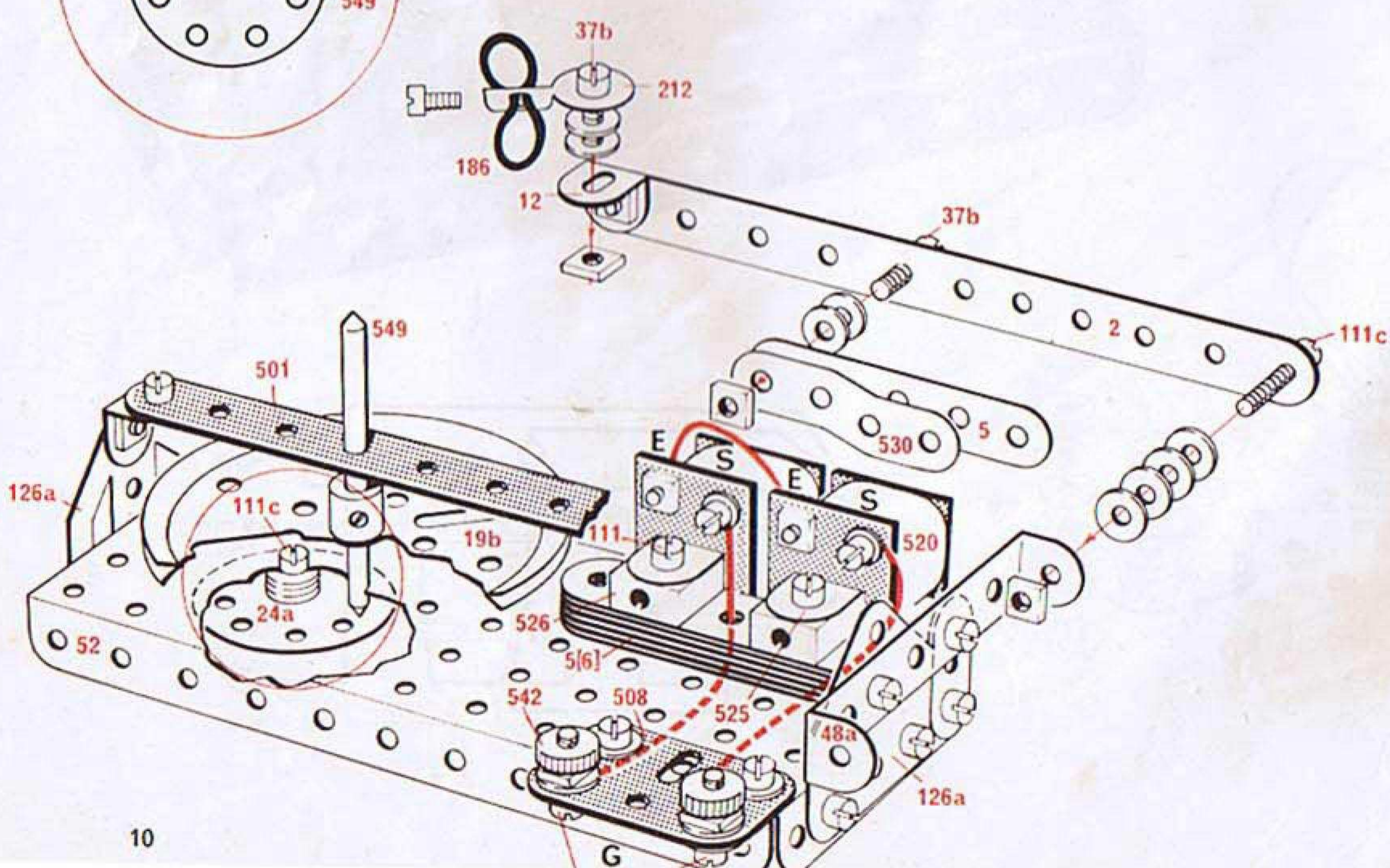
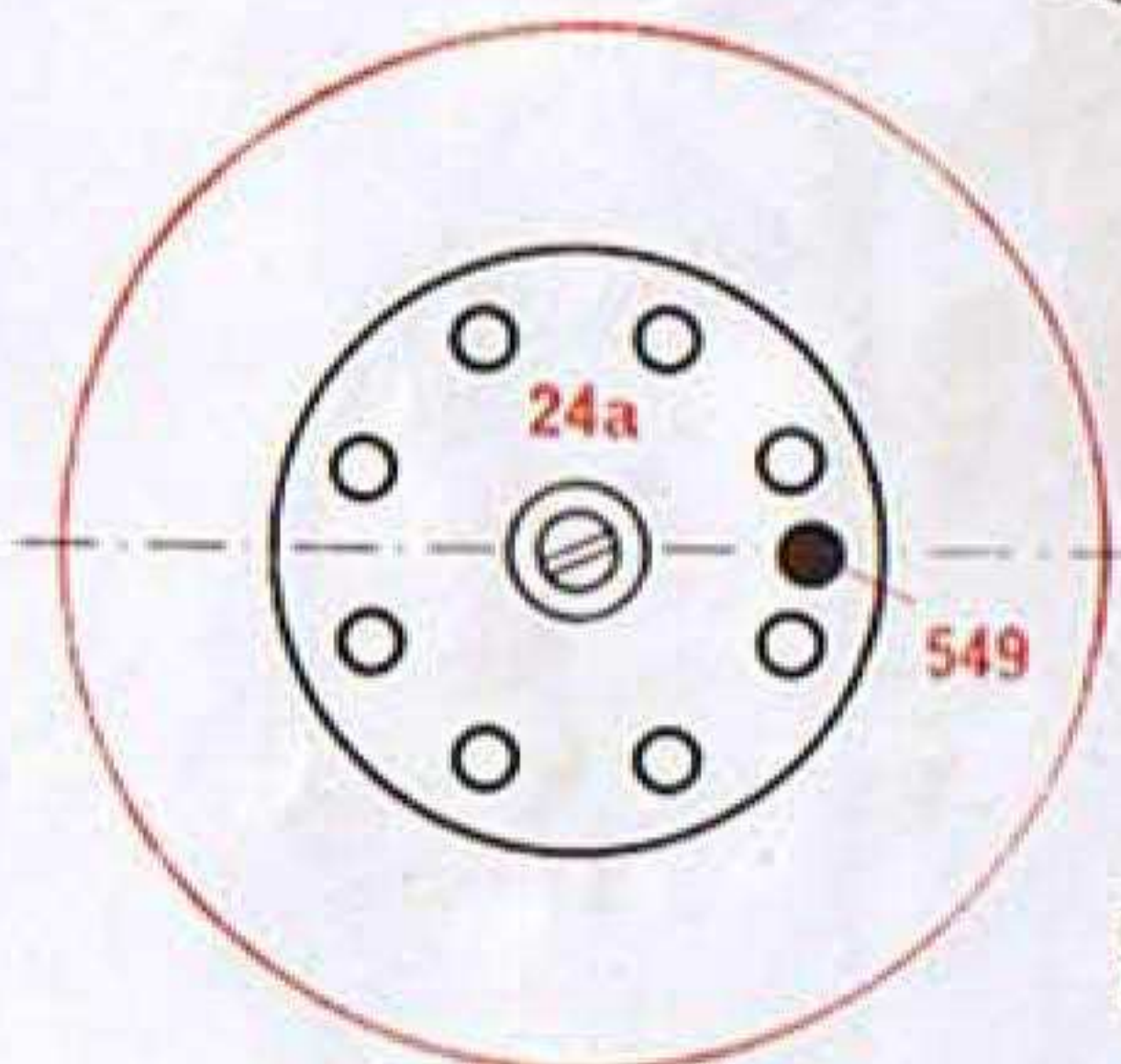
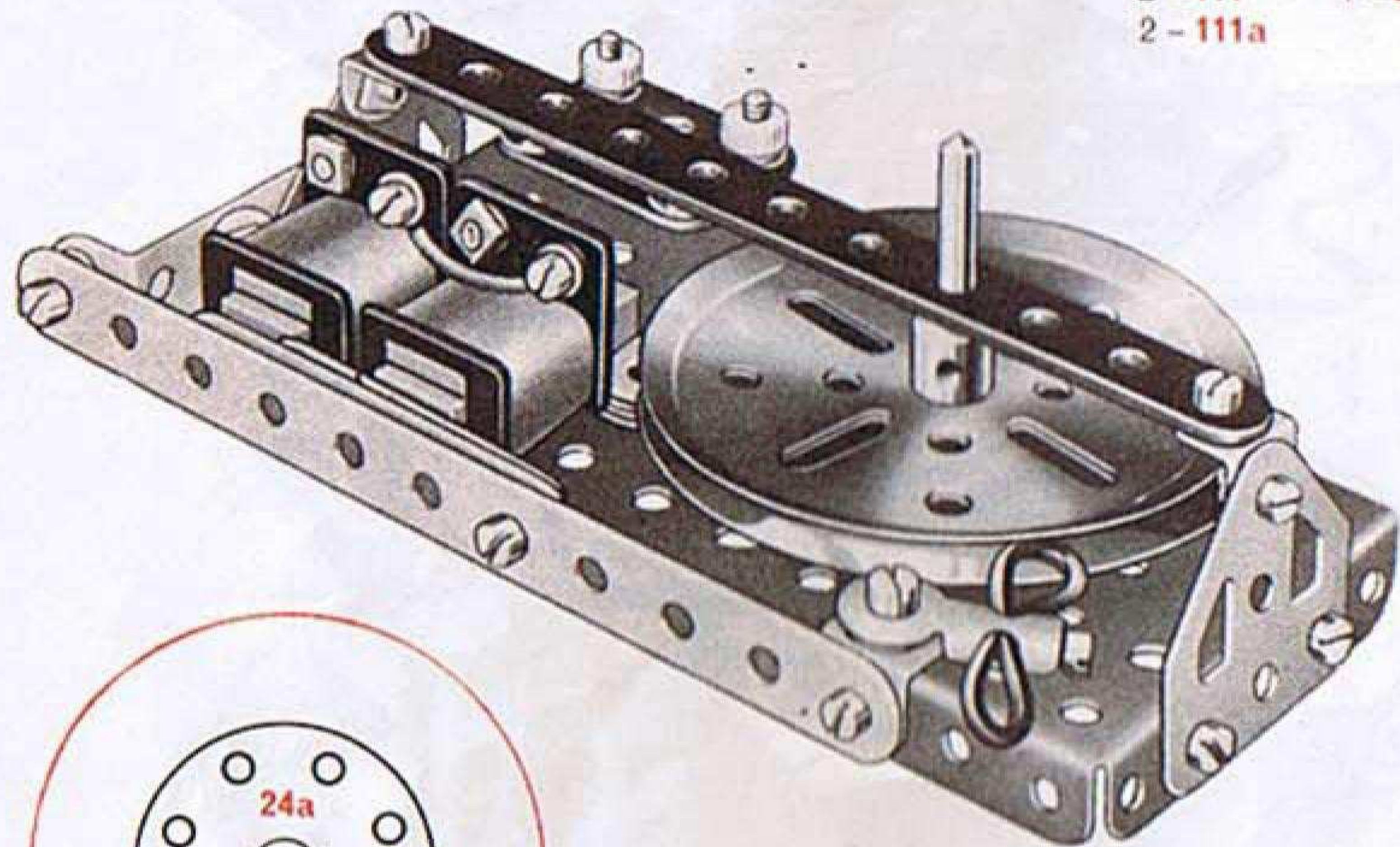

E11 Electric Bell

- 2 - 2
- 8 - 5
- 1 - 10
- 5 - 12
- 32 - 37a
- 23 - 37b
- 11 - 38
- 1 - 48a
- 2 - 111
- 3 - 111a
- 1 - 111d
- 1 - 508
- 1 - 510
- 2 - 520
- 4 - 525
- 2 - 526
- 1 - 530
- 1 - 531
- 2 - 542
- 1 - 543
- 1 - 562

This is an electric bell of the most common type.

The tone of the "ring" can be adjusted by moving the Contact Screw 543.

4-5v battery.
6-15v AC or DC.

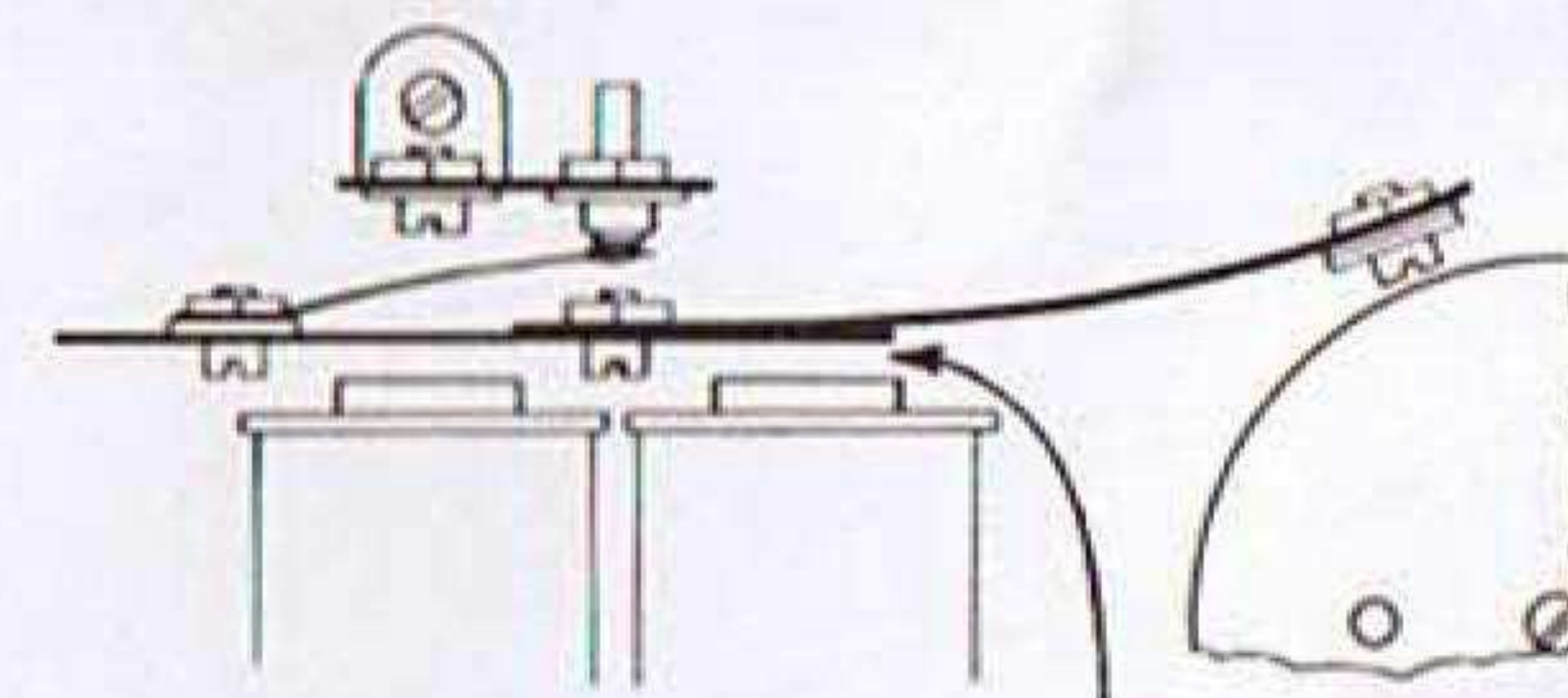
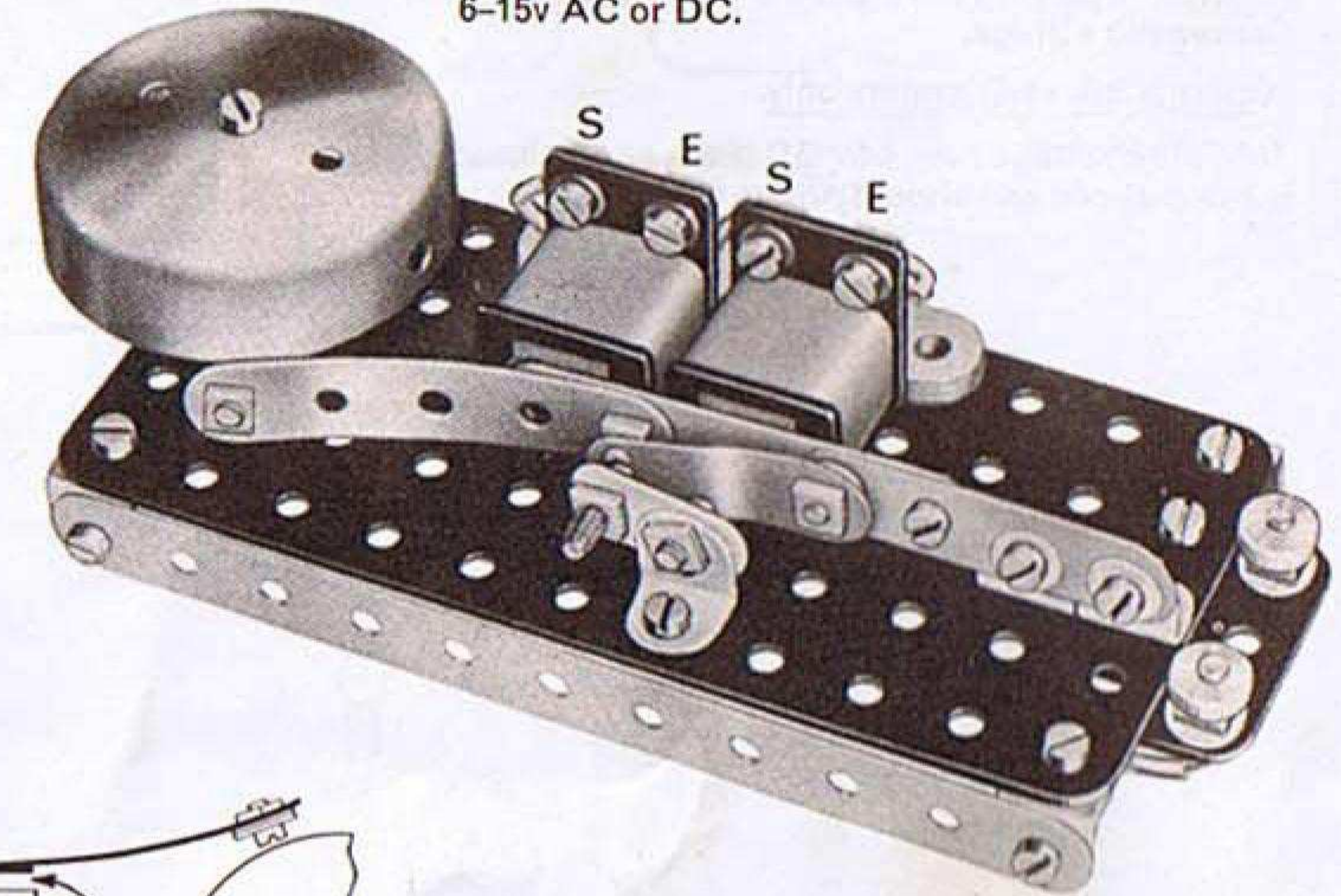

Air gap = thickness of Strip part 5.

Bend parts 530 and 531 slightly before assembly.

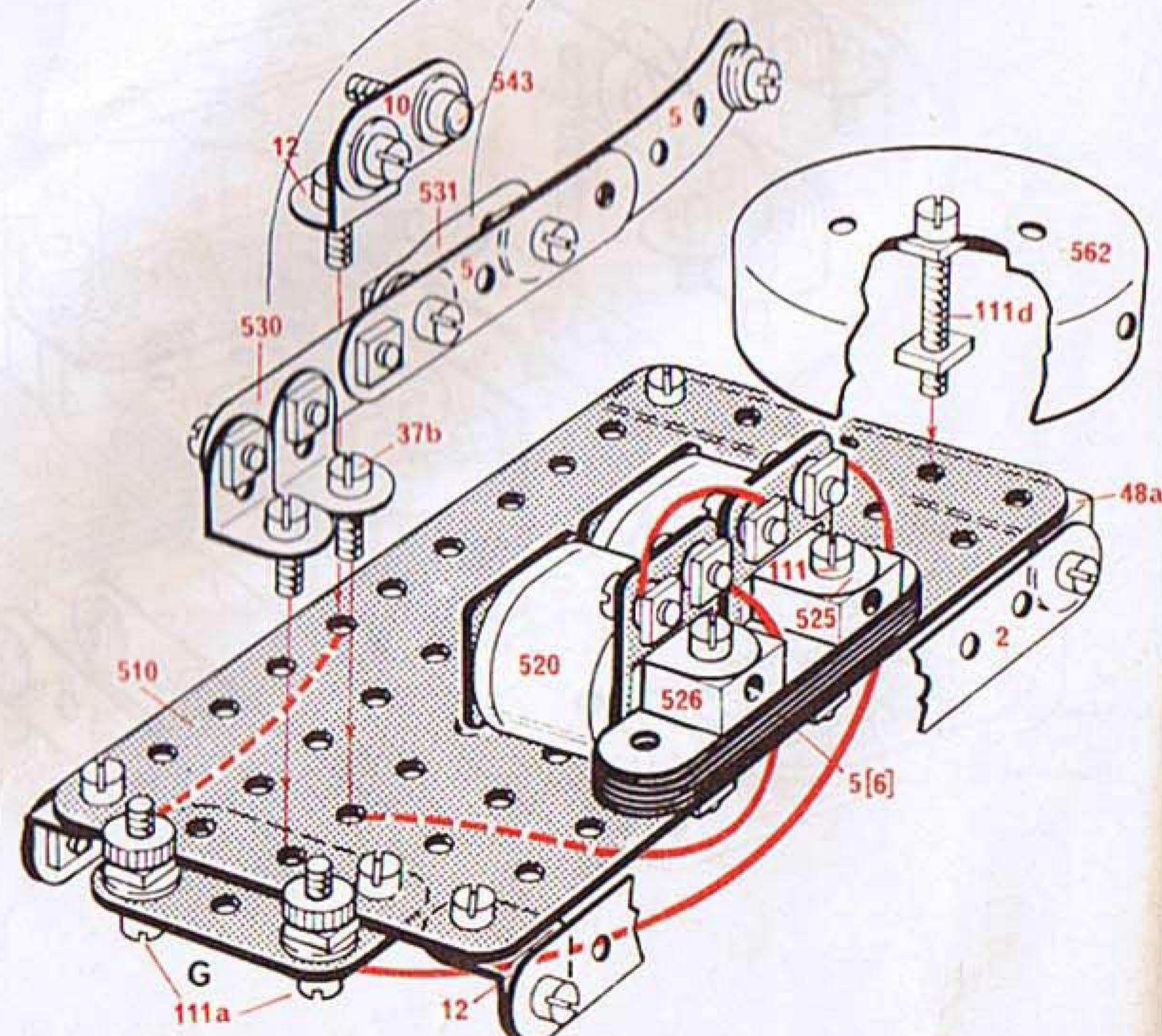

E12 Asynchronous Motor

A low-powered motor of a type often used in animated shop window displays. It is very silent in operation and capable of running for long periods without attention. It is an induction motor and does not have either brushes or commutator.

The motor starts and runs through the action of the copper Short Circuit Pieces 554 which cause a displacement of magnetic flux.

15v AC only.

This model can be fitted with cardboard dials 560b and 560e.

The Pivot Rod 549 should run freely between the retaining Pivot Bolts 545.

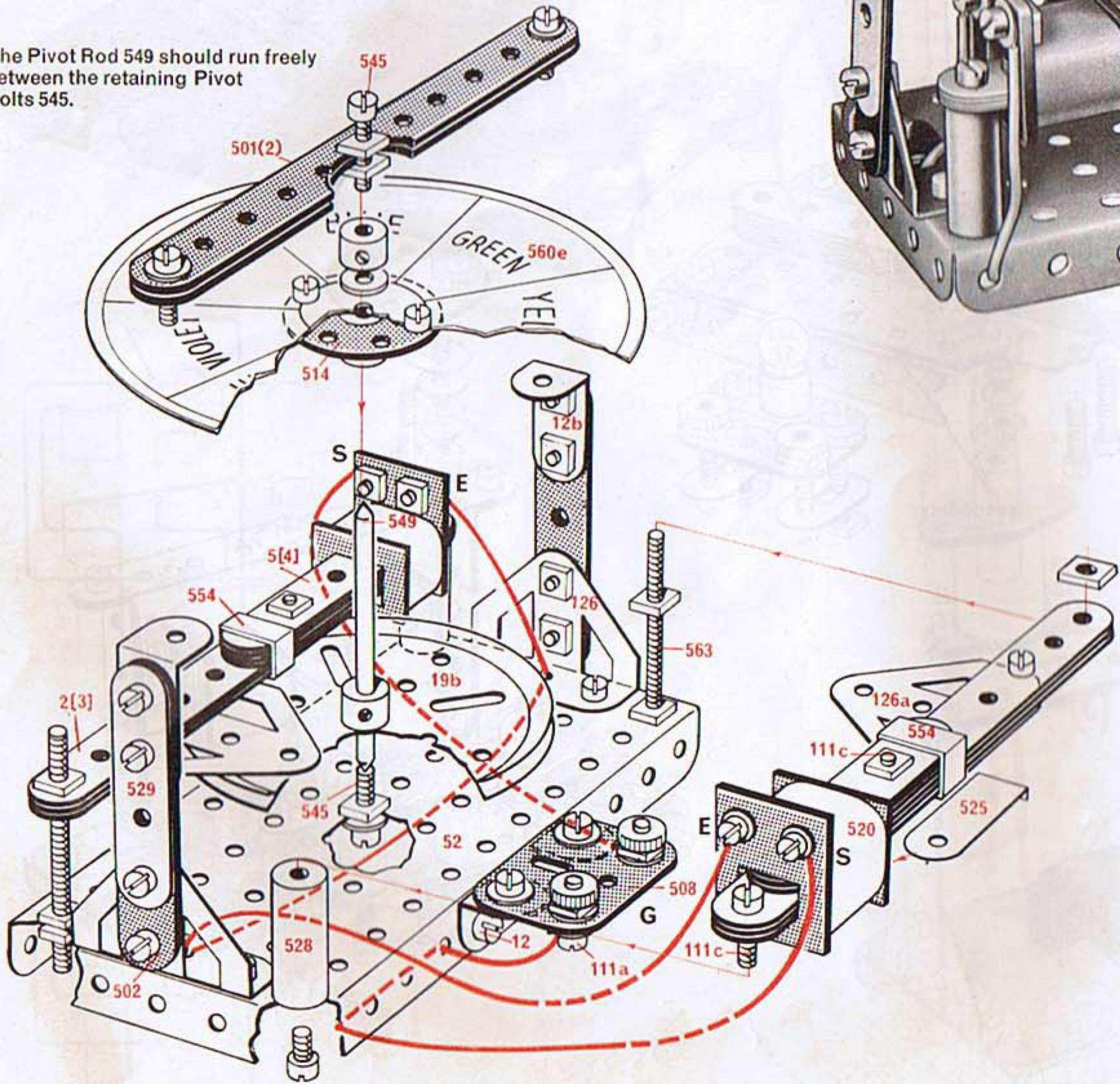
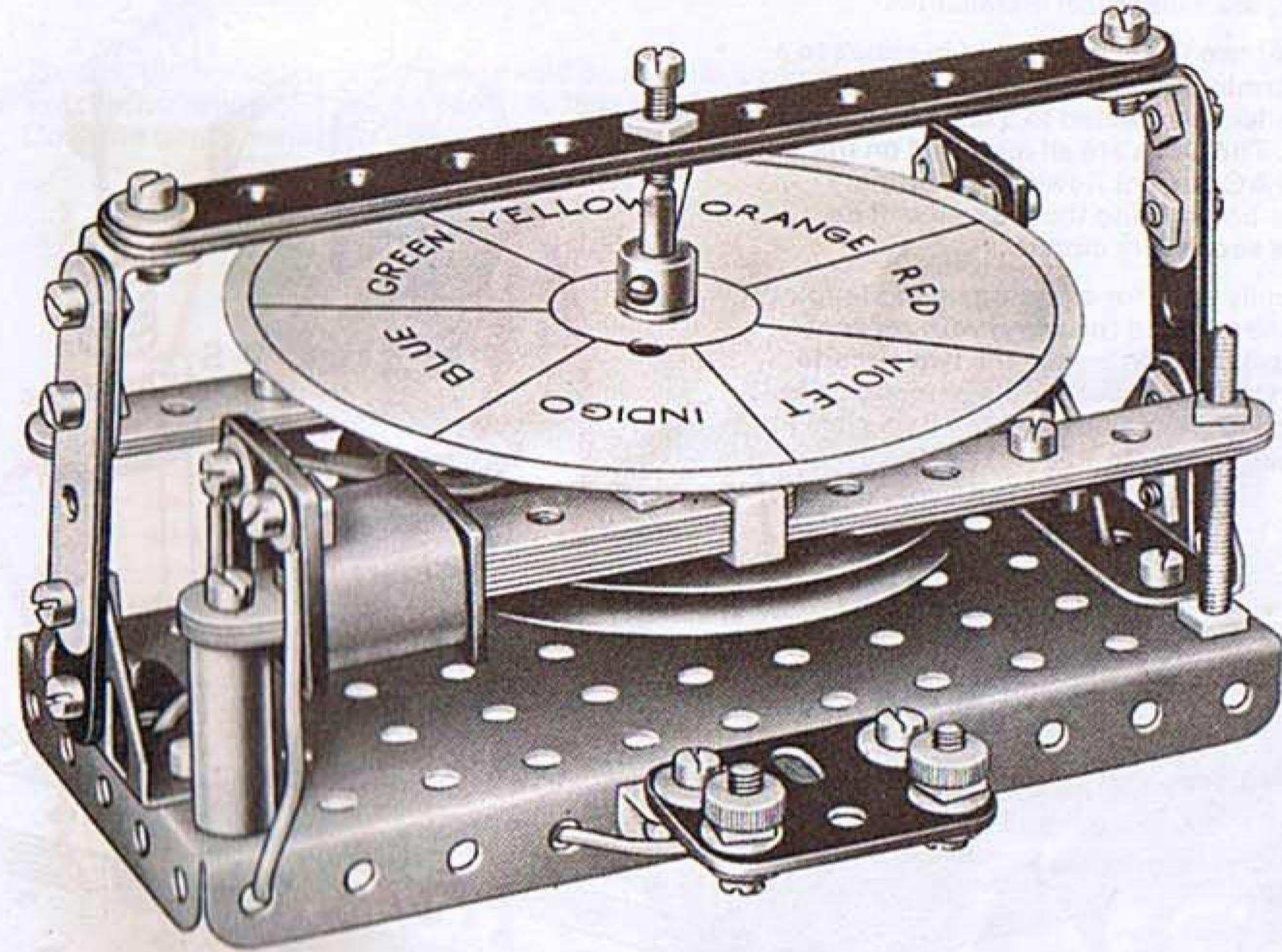

6 - 2	2 - 502
8 - 5	1 - 508
2 - 12	1 - 514
2 - 12b	2 - 520
1 - 19b	2 - 525
39 - 37a	2 - 528
25 - 37b	2 - 529
10 - 38	2 - 542
1 - 52	2 - 545
1 - 59	1 - 549
2 - 111a	2 - 554
4 - 111c	1 - 560b
2 - 111d	1 - 560e
2 - 126	4 - 561
2 - 126a	2 - 563
2 - 501	

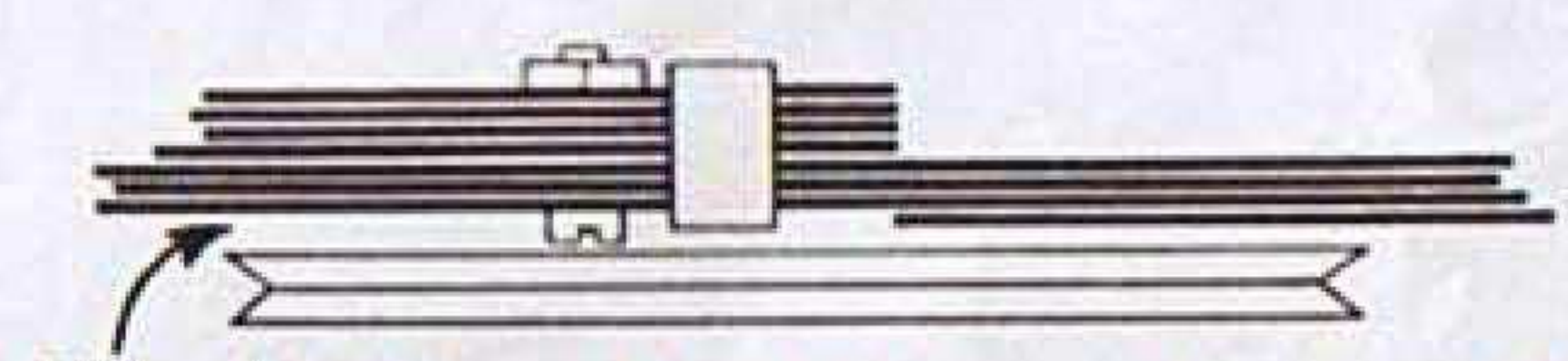

This clearance should be as small as possible.

E13 Transformer (1-1)

Transformers play a large part in industry and are often the principal elements in an electrical installation.

This model consists of two Coils connected in series to a supply at 15 volt AC forming the primary circuit, and two more Coils, also in series, connected to a lamp, forming the secondary circuit. The Coils are all mounted on the same core. When the AC current flows in the primary circuit the Lamp lights up showing the presence of an induced current in the secondary circuit.

Transformers are usually used for stepping up or stepping down the voltage of one winding (primary) with respect to the other (secondary), the currents in the two circuits being proportional to the number of windings in the coils. As the two pairs of coils in this model are the same it is in fact a 1 to 1 transformer.

- | | |
|----------|----------|
| 6 - 2 | 2 - 501 |
| 8 - 5 | 1 - 508 |
| 2 - 10 | 1 - 510 |
| 26 - 37a | 2 - 520 |
| 16 - 37b | 2 - 522 |
| 16 - 38 | 2 - 528 |
| 2 - 48a | 1 - 539 |
| 2 - 111 | 1 - 540c |
| 4 - 111a | 4 - 542 |
| 8 - 111c | 10 - 561 |
| 2 - 111d | |

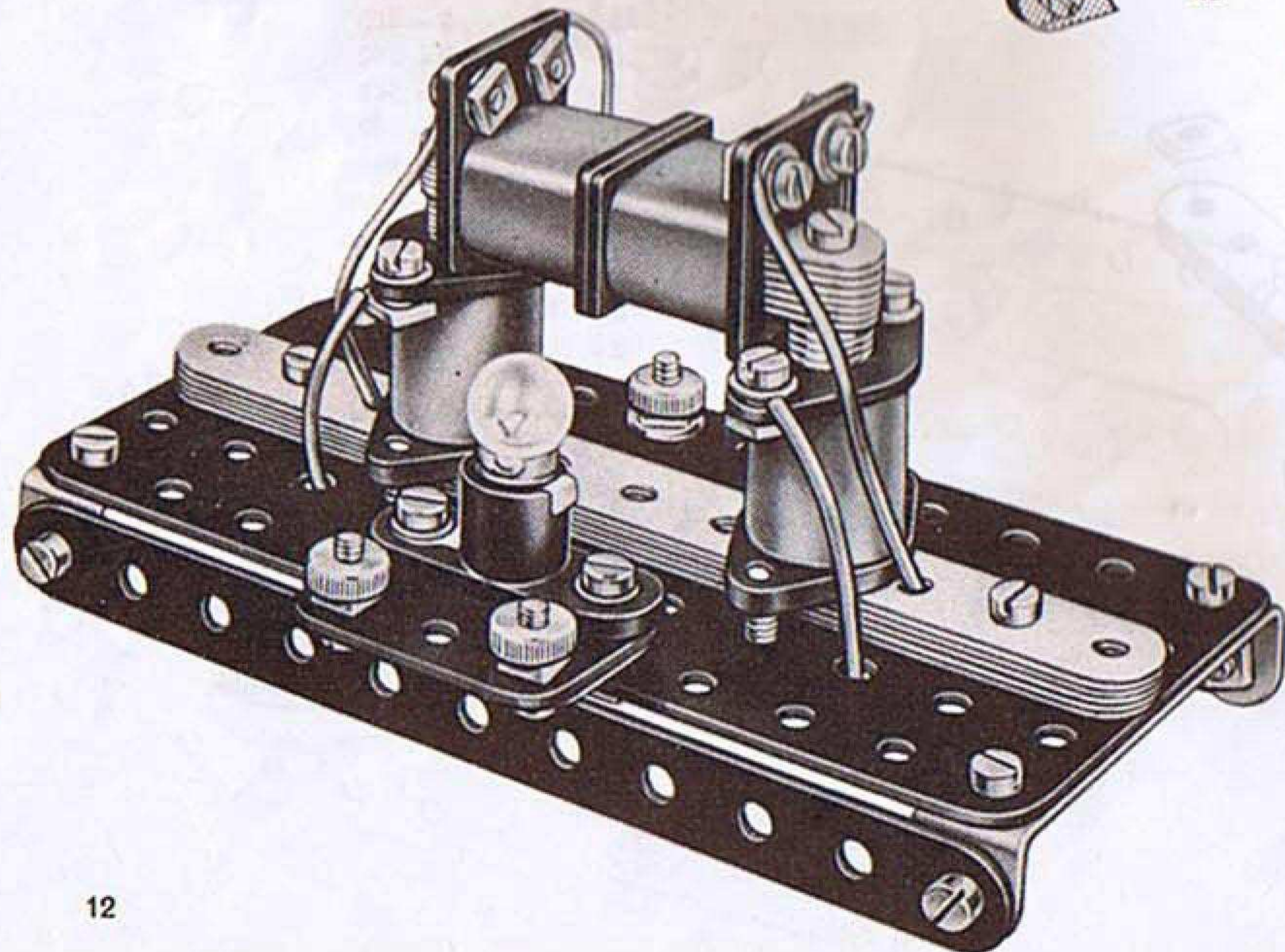
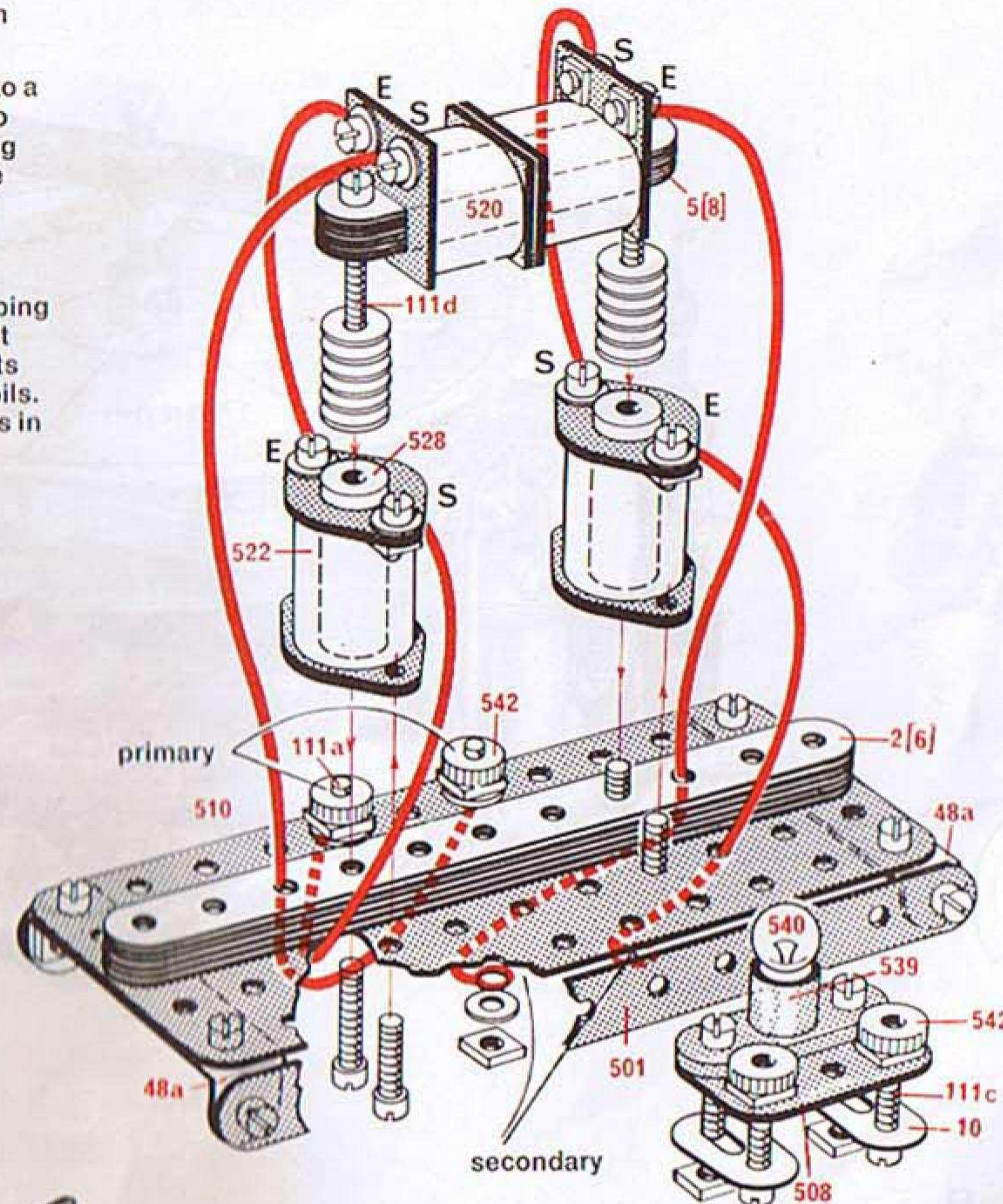

E14 Two-way Relay Switch with

Depending upon the polarity of the current fed into it, this relay switch will operate either of two separate circuits.

One of the two Lamps lights up showing which of the circuits is closed.

4.5v battery.
6-12v DC only.

NB An independent current supply G2 is required to operate the separate circuits.
The Permanent Magnet in this model acts only as a counterweight.

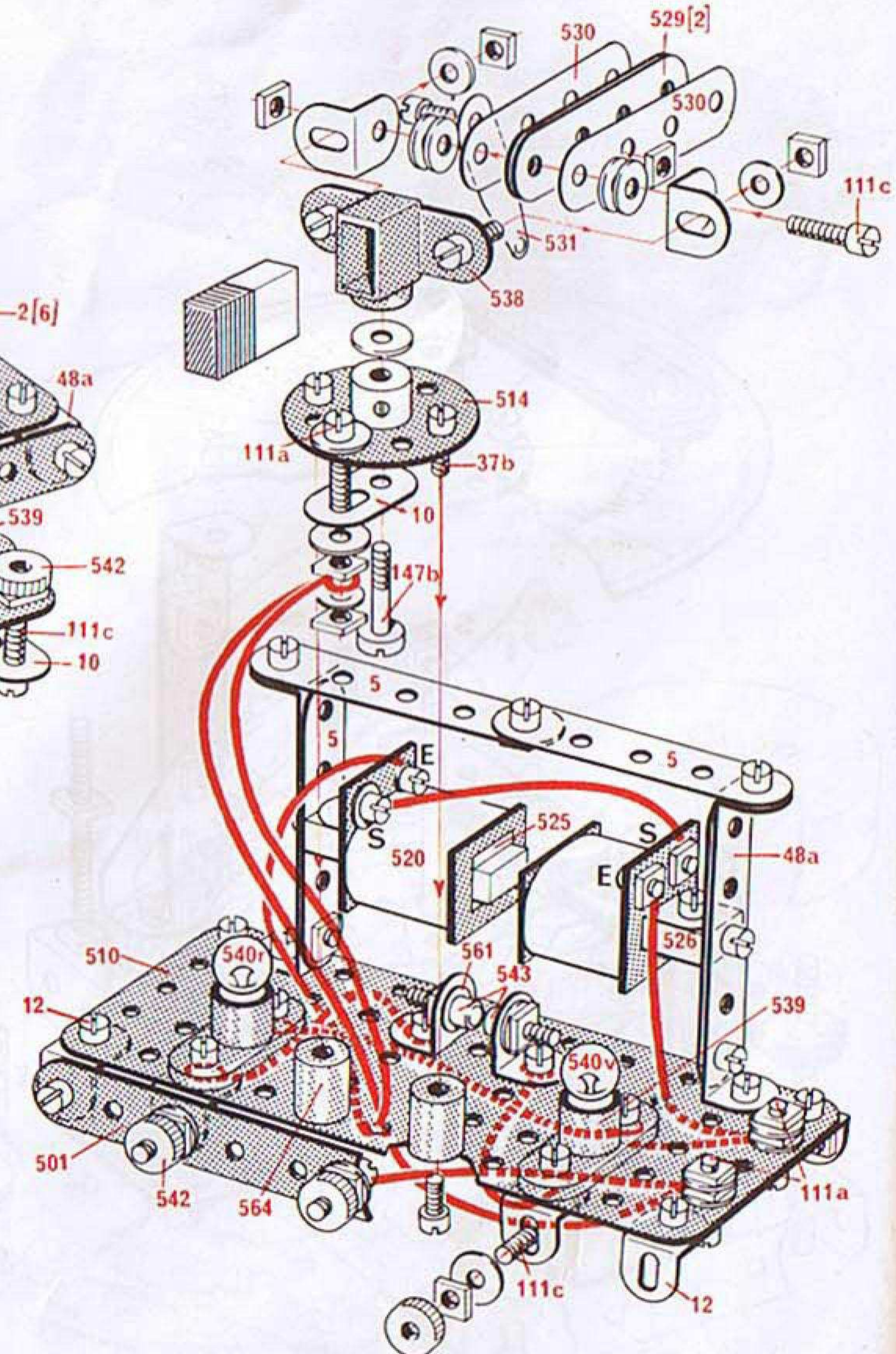

A very low-powered motor of the type used in electric clocks.

15v AC only.

To start the motor the Pivot Rod should be spun at a speed synchronous with the AC current (i.e. 750 r.p.m.) until the Coils are gently swinging above the wheel.

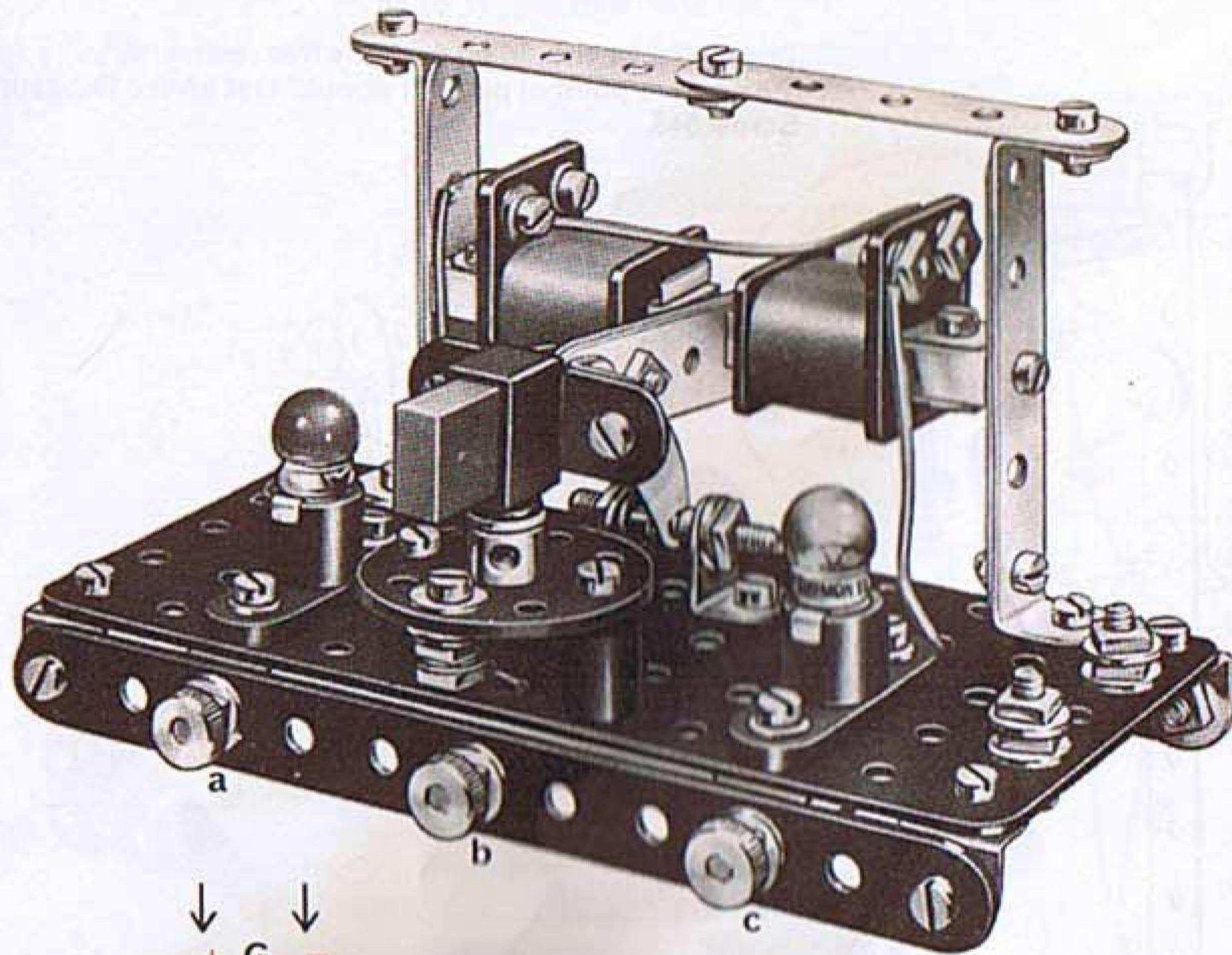

- | | | |
|---------|----------|---------|
| 2 - 2 | 4 - 35 | 1 - 212 |
| 2 - 5 | 32 - 37a | 1 - 501 |
| 2 - 10 | 32 - 37b | 1 - 508 |
| 2 - 11 | 26 - 38 | 1 - 510 |
| 4 - 12 | 2 - 48a | 2 - 522 |
| 2 - 12b | 1 - 59 | 2 - 528 |
| 1 - 18a | 2 - 111a | 2 - 529 |
| 1 - 18b | 3 - 111c | 4 - 542 |
| 1 - 19b | 2 - 126 | 1 - 548 |

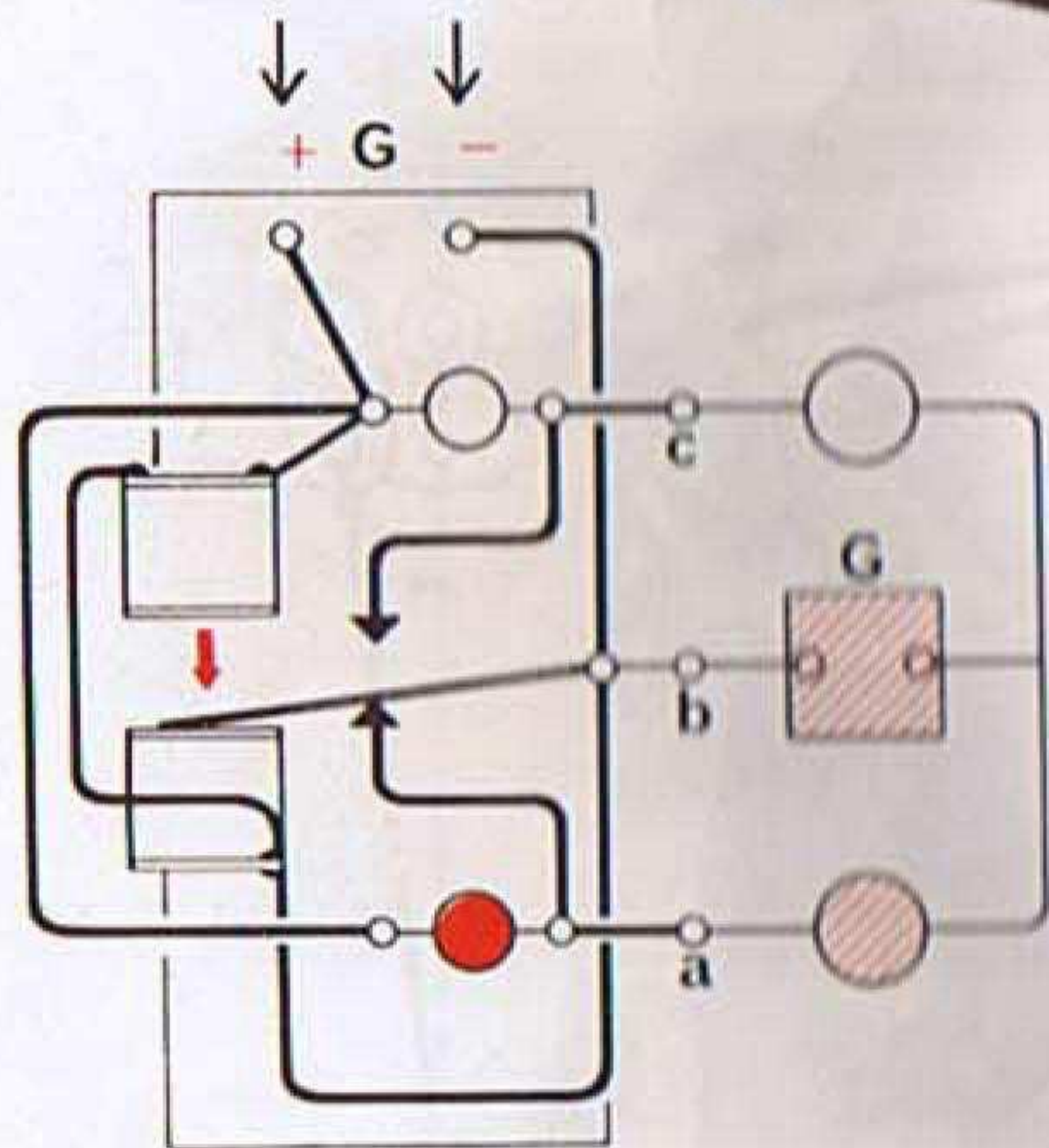
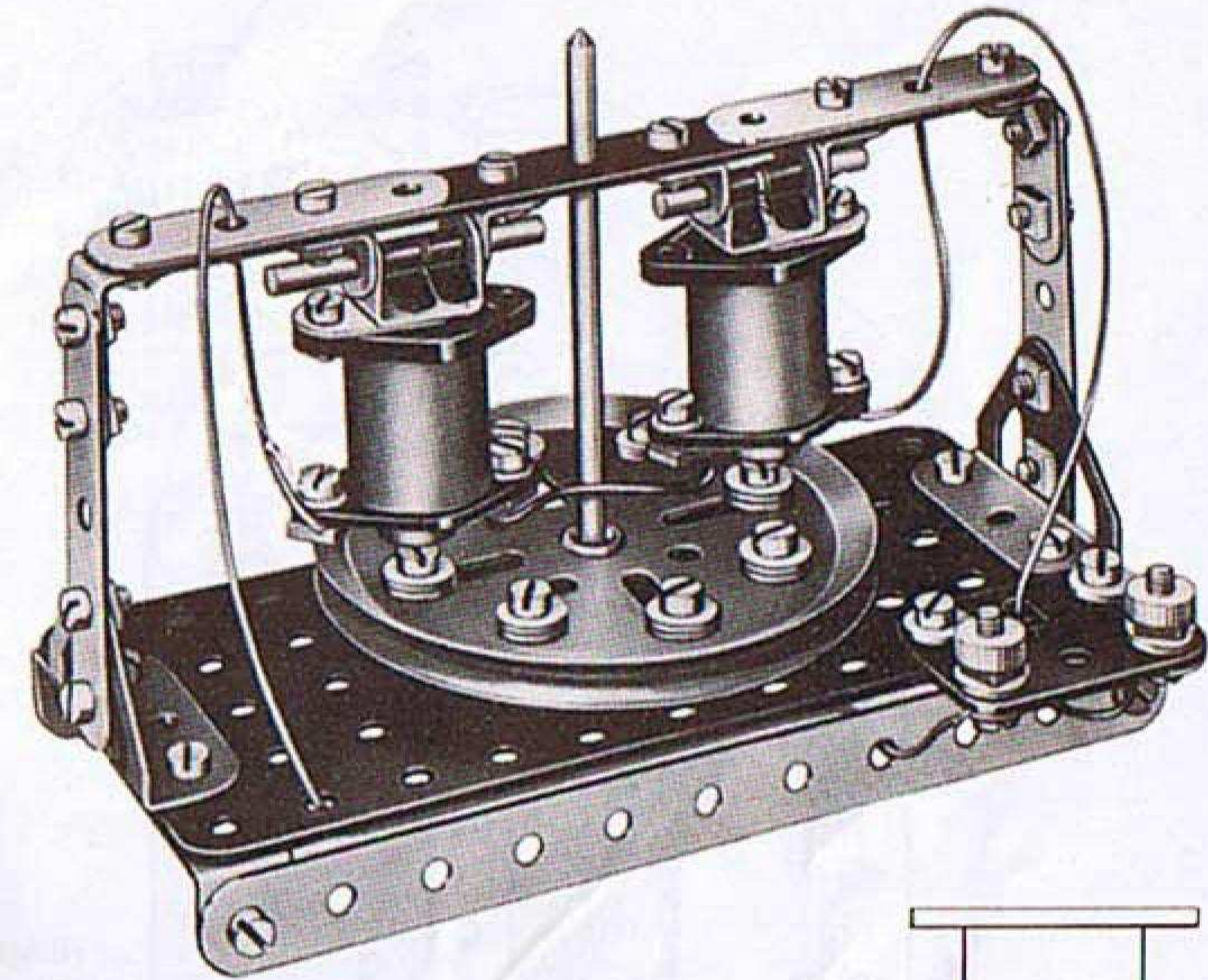

- | |
|-----------|
| 4 - 5 |
| 1 - 10 |
| 10 - 12 |
| 40 - 37a |
| 28 - 37b |
| 20 - 38 |
| 2 - 48a |
| 2 - 111a |
| 13 - 111c |
| 1 - 147b |
| 2 - 501 |
| 1 - 510 |
| 1 - 514 |
| 2 - 520 |
| 4 - 525 |
| 2 - 526 |
| 2 - 529 |
| 2 - 530 |
| 1 - 531 |
| 1 - 537 |
| 1 - 538 |
| 2 - 539 |
| 1 - 540r |
| 1 - 540v |
| 3 - 542 |
| 2 - 543 |
| 11 - 561 |
| 2 - 564 |

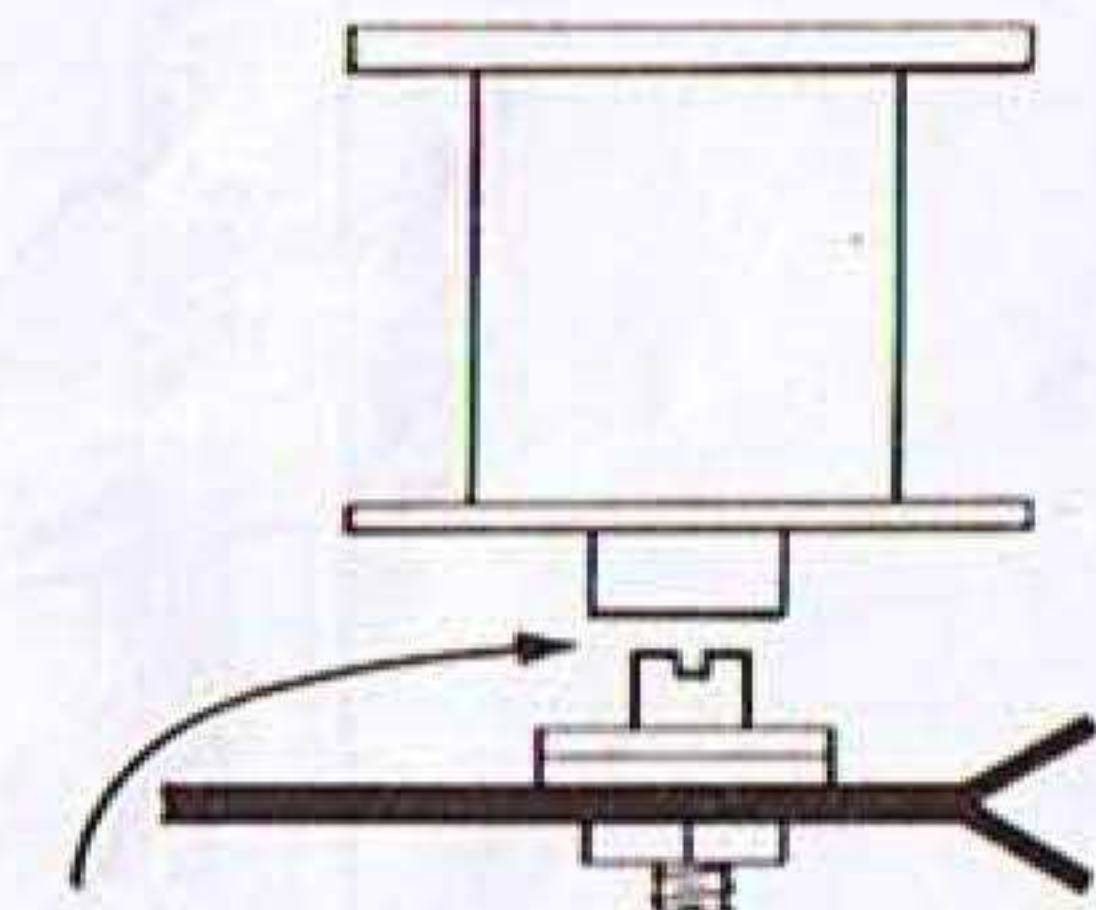
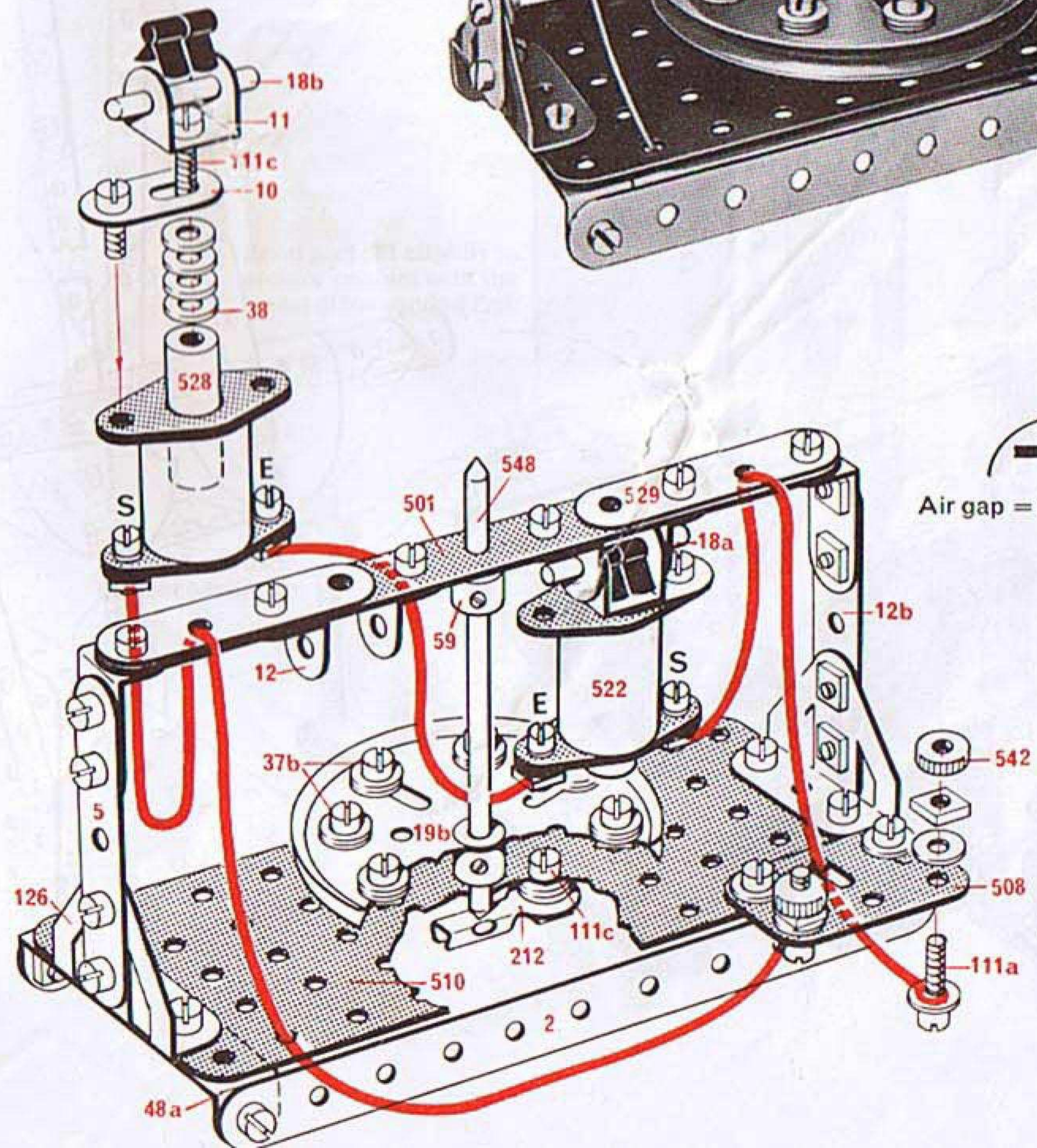

Air gap = thickness of Strip part 5.

E16 Swing

12-15v AC or DC. This model will not work efficiently on a power supply below 12 volts.

At the end of each swing in one direction part 531 makes contact supplying current to the Coils, which attract the Cores attached to the string and thus pull the swing in the other direction.

To set the model in motion give the swing a gentle push.

- | | |
|--------|--------|
| 2-1 | 1-115 |
| 6-2 | 1-126a |
| 9-5 | 2-140y |
| 1-10 | 1-147b |
| 1-11 | 2-214 |
| 8-12 | 2-501 |
| 2-12b | 1-503 |
| 2-12c | 1-508 |
| 1-15b | 1-510 |
| 1-24 | 1-511 |
| 1-35 | 1-514 |
| 55-37a | 1-516 |
| 52-37b | 2-522 |
| 24-38 | 2-527 |
| 2-48a | 2-531 |
| 1-52 | 1-533 |
| 1-59 | 4-542 |
| 3-111a | 1-543 |
| 4-111c | 13-561 |

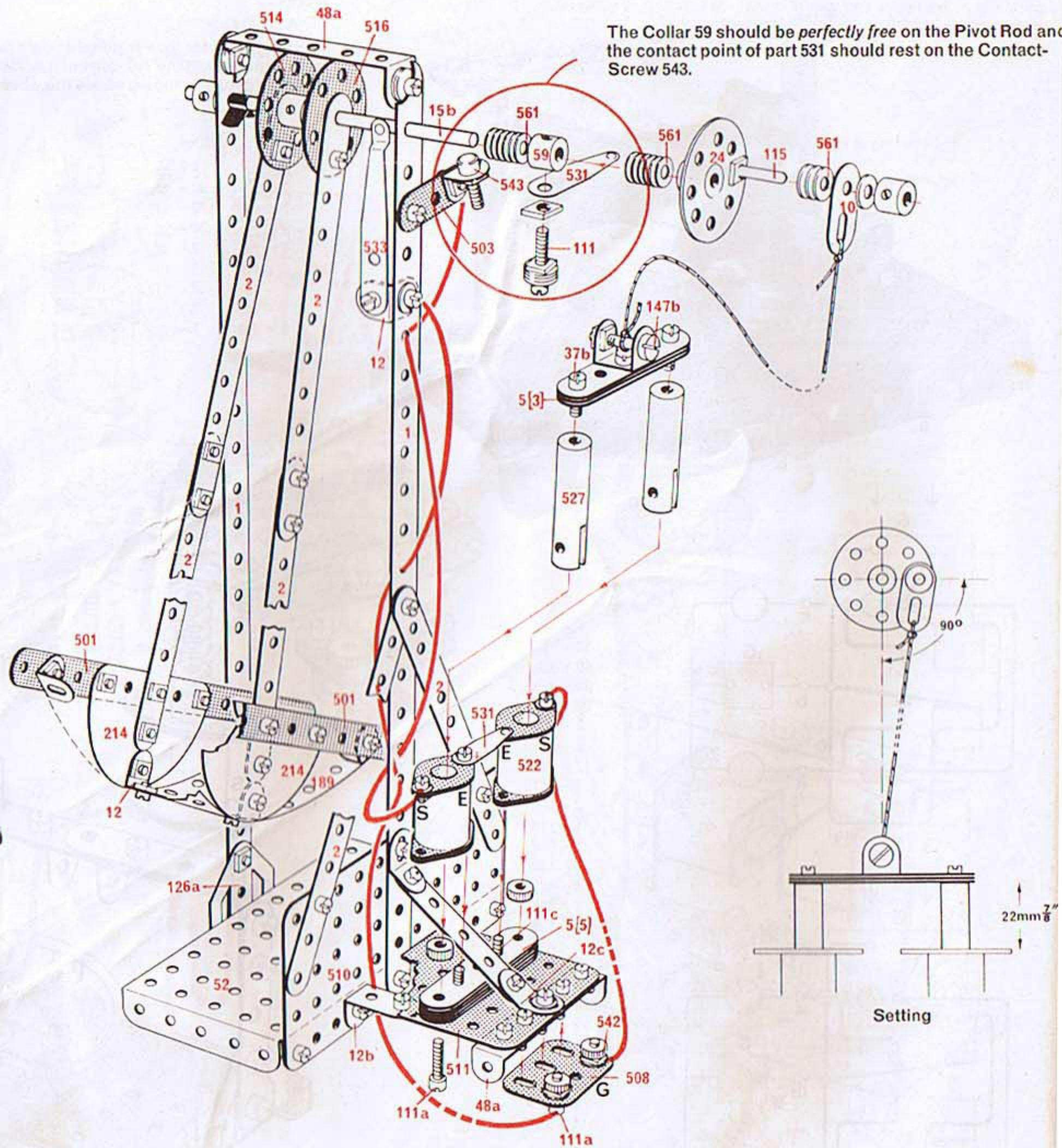
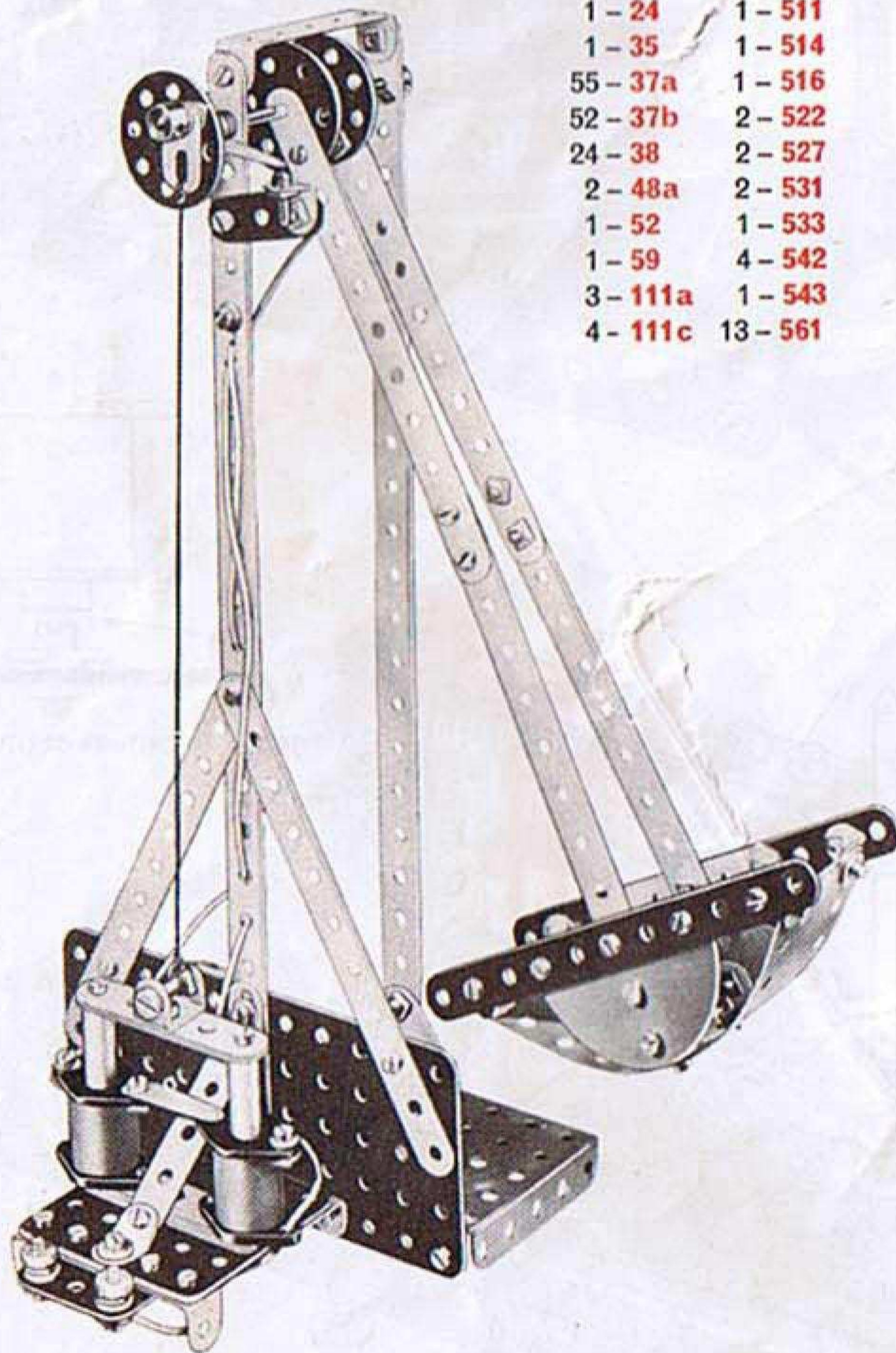

E17 Windmill

This model incorporates a novel motor. The rotary motion is caused by short, jerky movements of the cord over the large Pulley 19b.

15v AC only.

- | | |
|----------|---------|
| 5 - 2 | 2 - 189 |
| 2 - 5 | 2 - 190 |
| 1 - 15b | 2 - 214 |
| 1 - 19b | 4 - 221 |
| 1 - 22 | 2 - 501 |
| 1 - 24 | 1 - 503 |
| 1 - 24a | 1 - 510 |
| 53 - 37a | 1 - 511 |
| 48 - 37b | 2 - 522 |
| 27 - 38 | 1 - 526 |
| 1 - 38d | 2 - 528 |
| 2 - 48a | 1 - 530 |
| 1 - 52 | 2 - 531 |
| 1 - 59 | 1 - 538 |
| 2 - 111 | 4 - 542 |
| 4 - 111a | 1 - 543 |
| 1 - 126a | 2 - 561 |
| 1 - 140y | 1 - 563 |
| 2 - 188 | |

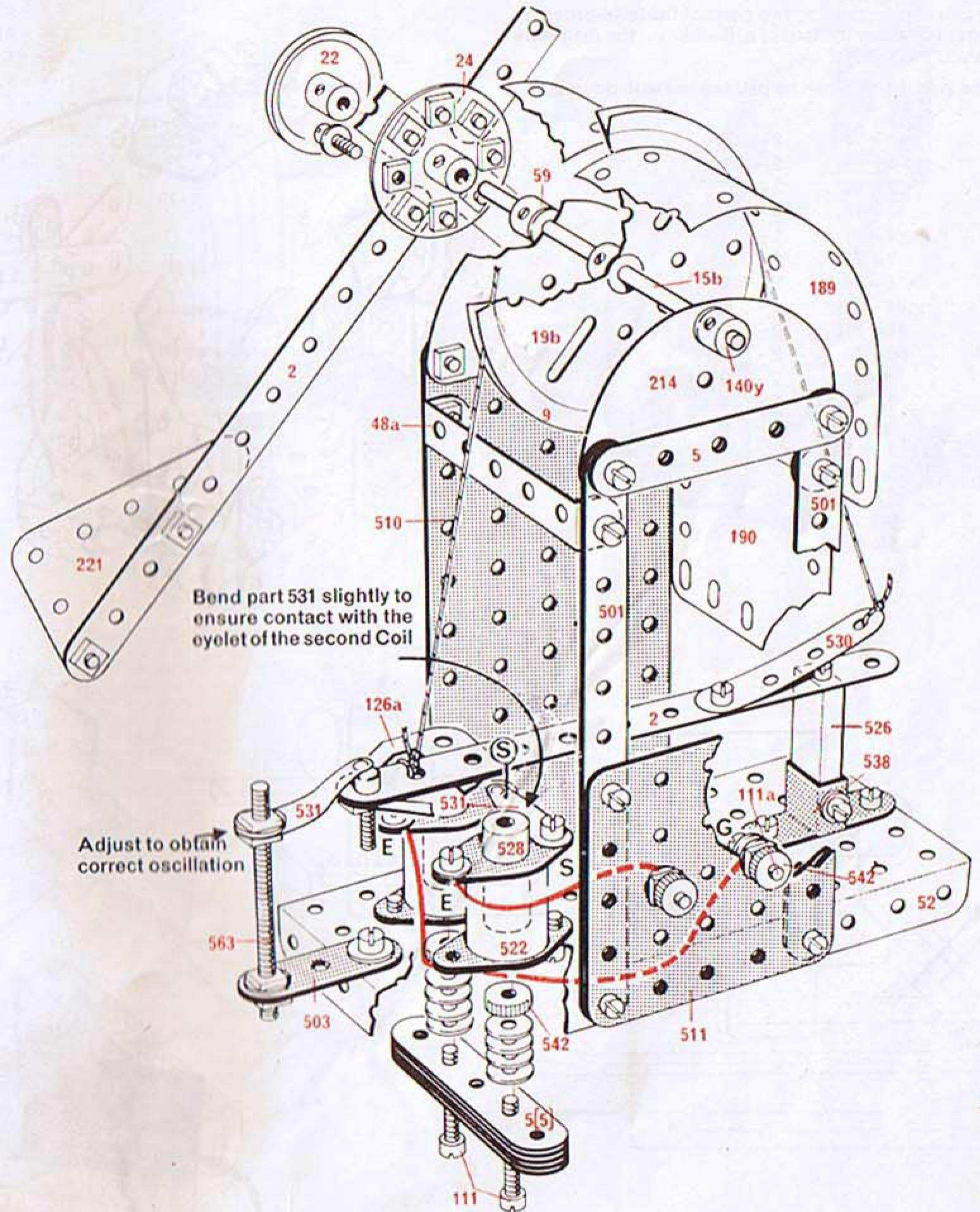
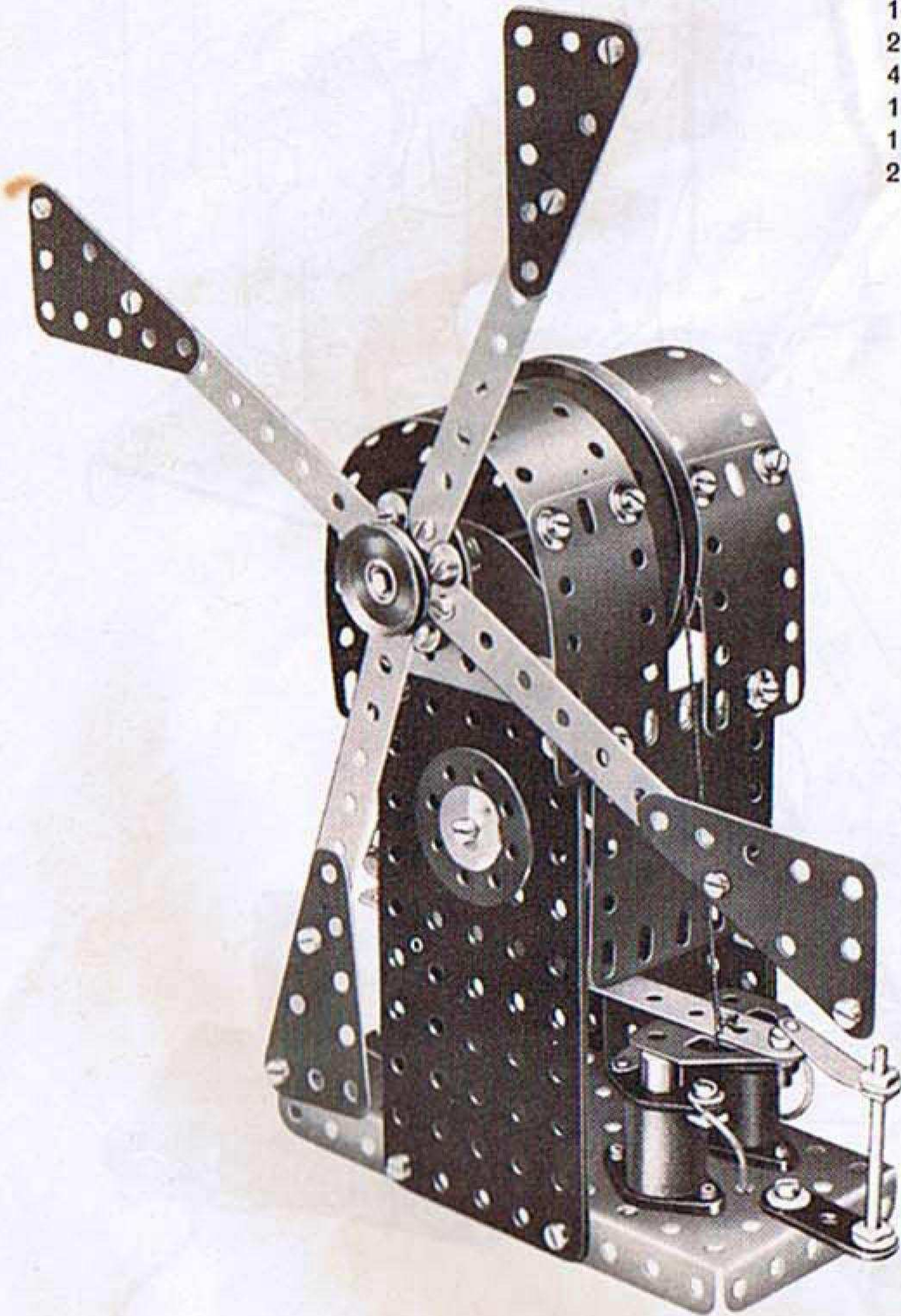

E18 Level-Crossing

A level-crossing of the type used on Continental railways. It can be used with 'O' gauge railways. The warning lamps light up when the barriers are down.

12v DC or 15v AC.

This model does not work efficiently below 12 volts.

When connecting the two parts of the level-crossing together follow the letters a, b and c on the diagrams carefully.

The yellow Lamp can be painted red with poster paint.

- | | |
|-----------|----------|
| 2 - 2 | 2 - 501 |
| 6 - 5 | 2 - 502 |
| 1 - 10 | 1 - 507 |
| 2 - 11 | 1 - 510 |
| 2 - 12 | 1 - 511 |
| 2 - 12b | 2 - 513 |
| 2 - 24a | 2 - 522 |
| 64 - 37a | 2 - 526 |
| 44 - 37b | 2 - 527 |
| 50 - 38 | 2 - 529 |
| 2 - 48a | 2 - 530 |
| 1 - 52 | 1 - 531 |
| 3 - 111 | 2 - 534 |
| 6 - 111a | 2 - 539 |
| 12 - 111c | 1 - 540r |
| 2 - 126 | 1 - 540j |
| 2 - 126a | 4 - 542 |
| 2 - 140y | |

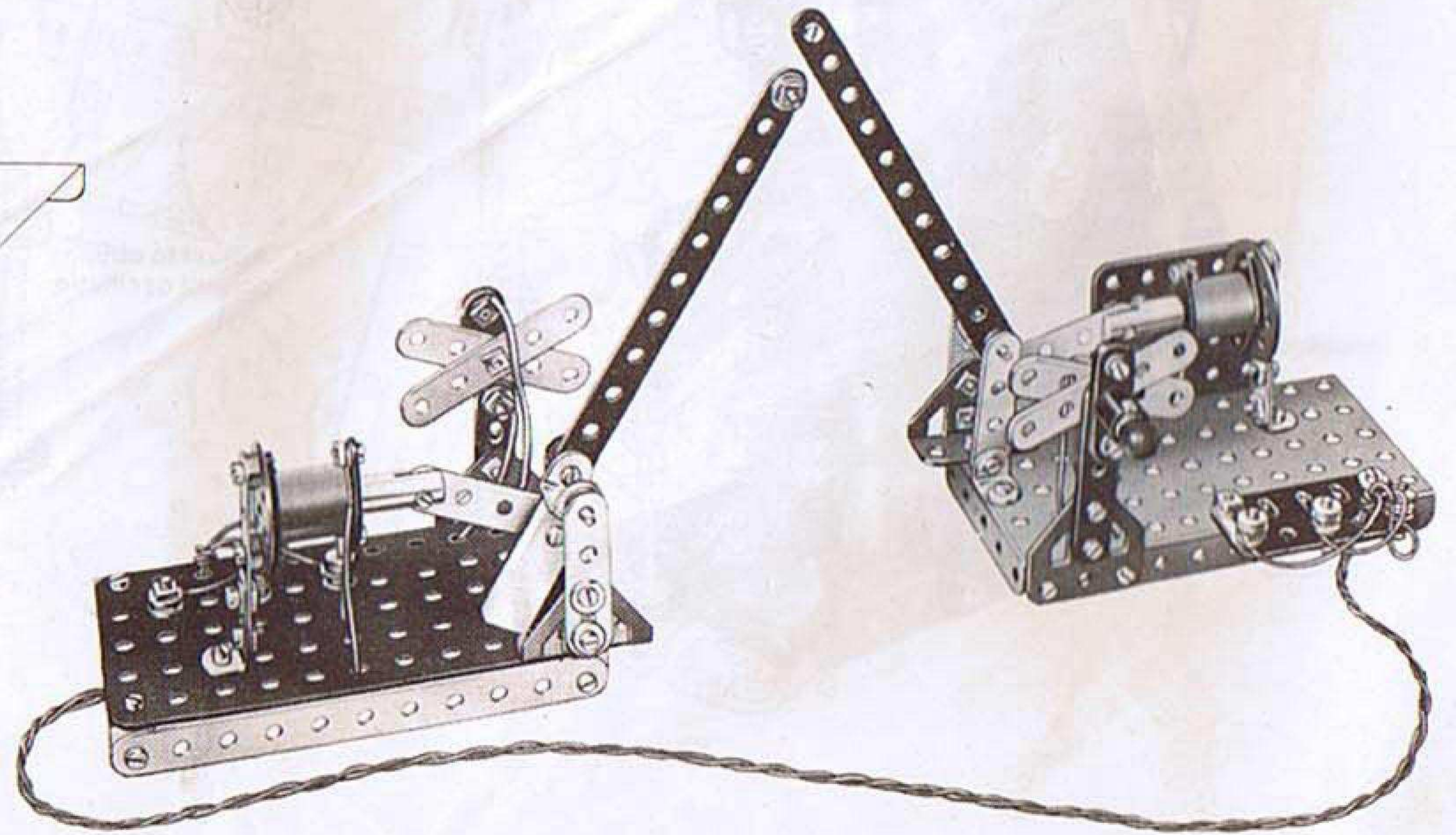
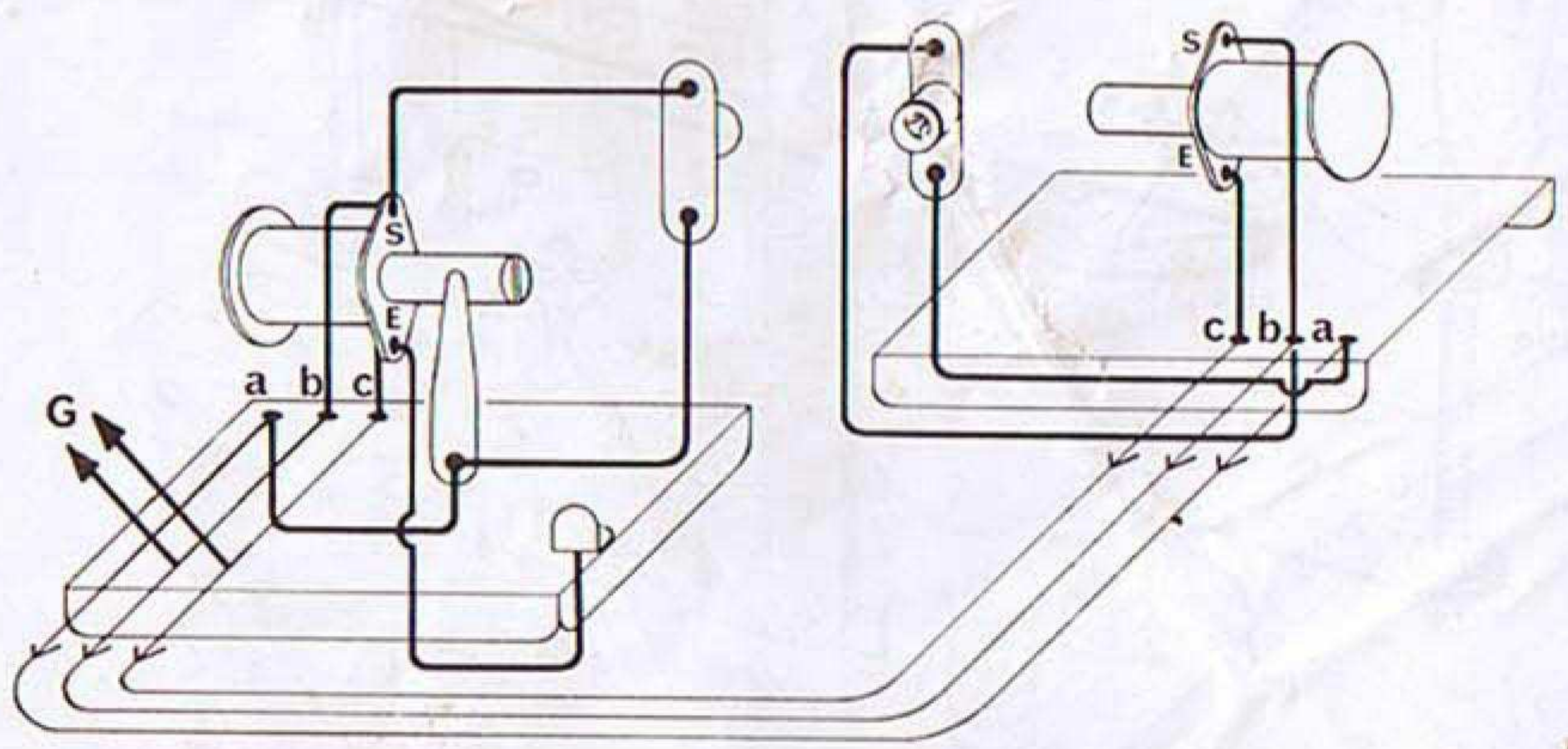
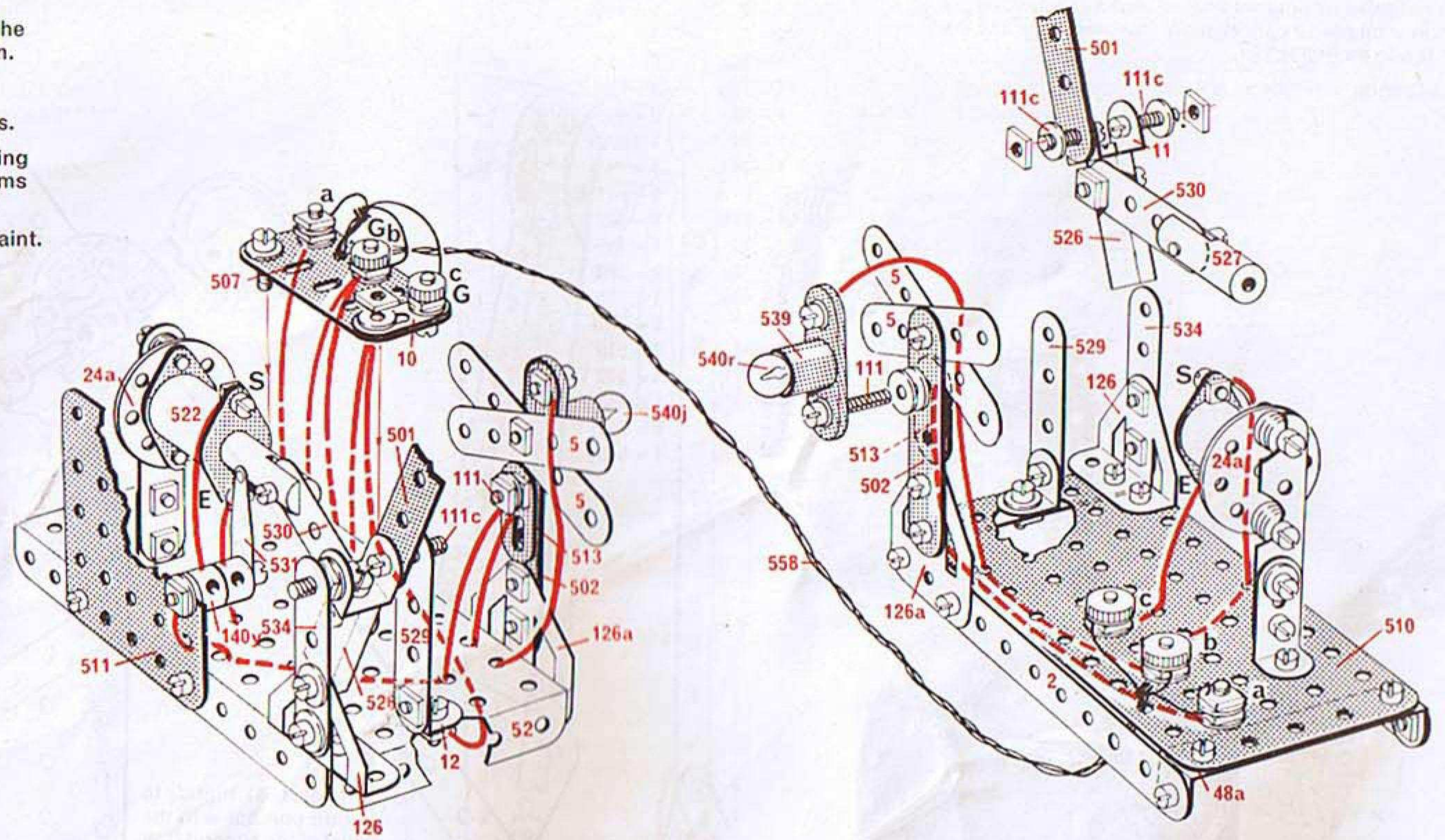

E19 2-Light Signal with Relay Switch

This remote control signal, which incorporates a relay switch, can be used with an 'O' gauge railway.

12v DC or 15v AC.

This model does not work efficiently on a current supply below 12 volts.

- | | | |
|----------|----------|----------|
| 3 - 2 | 1 - 111d | 1 - 526 |
| 4 - 10 | 2 - 126 | 2 - 532 |
| 2 - 11 | 2 - 140y | 1 - 533 |
| 7 - 12 | 1 - 147b | 2 - 539 |
| 2 - 12b | 2 - 501 | 1 - 540r |
| 57 - 37a | 2 - 502 | 1 - 540v |
| 33 - 37b | 2 - 503 | 4 - 542 |
| 10 - 38 | 1 - 507 | 2 - 543 |
| 2 - 48a | 1 - 510 | 2 - 544 |
| 3 - 111 | 1 - 511 | 11 - 561 |
| 8 - 111a | 1 - 513 | 2 - 564 |
| 4 - 111c | 2 - 520 | |

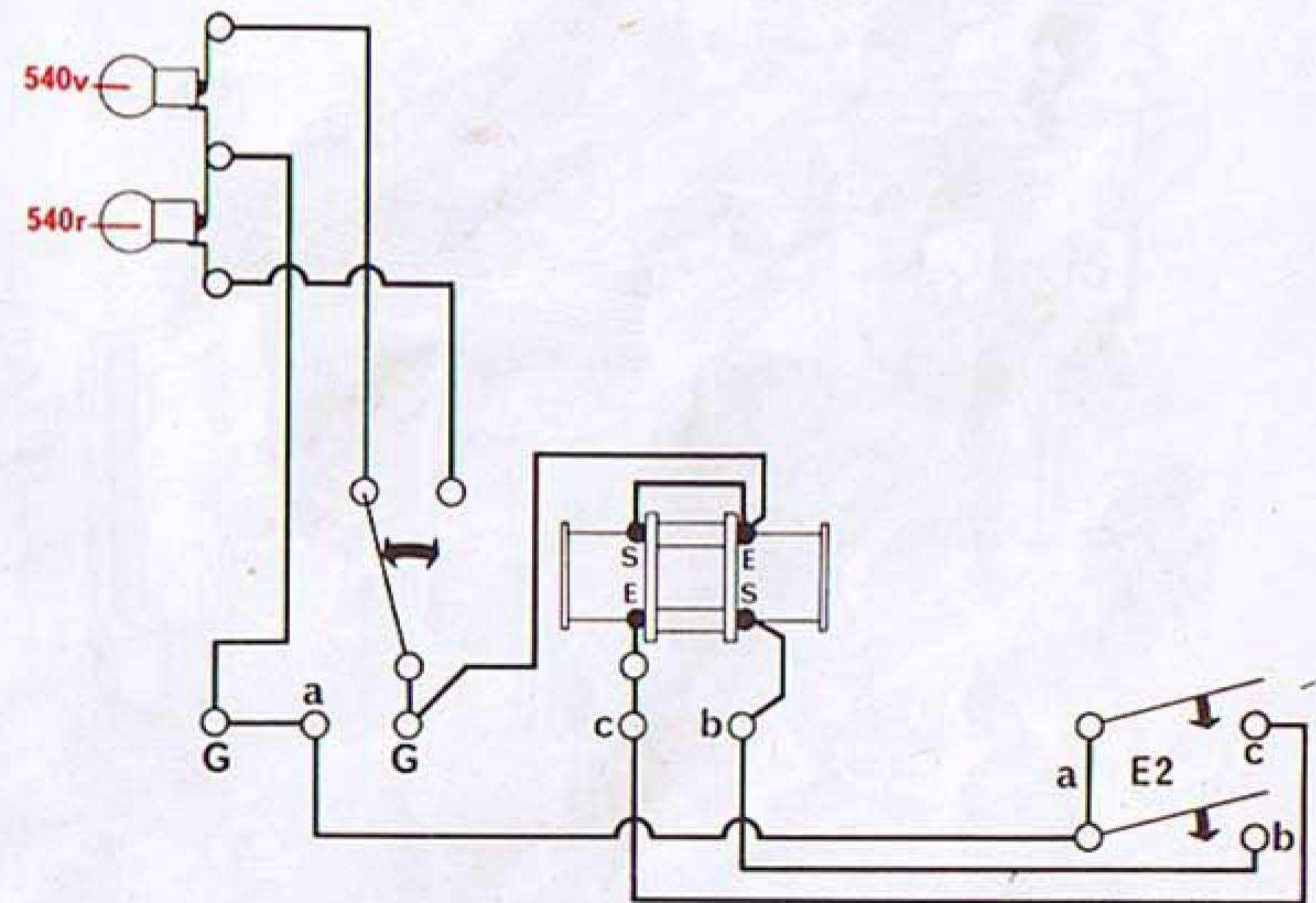
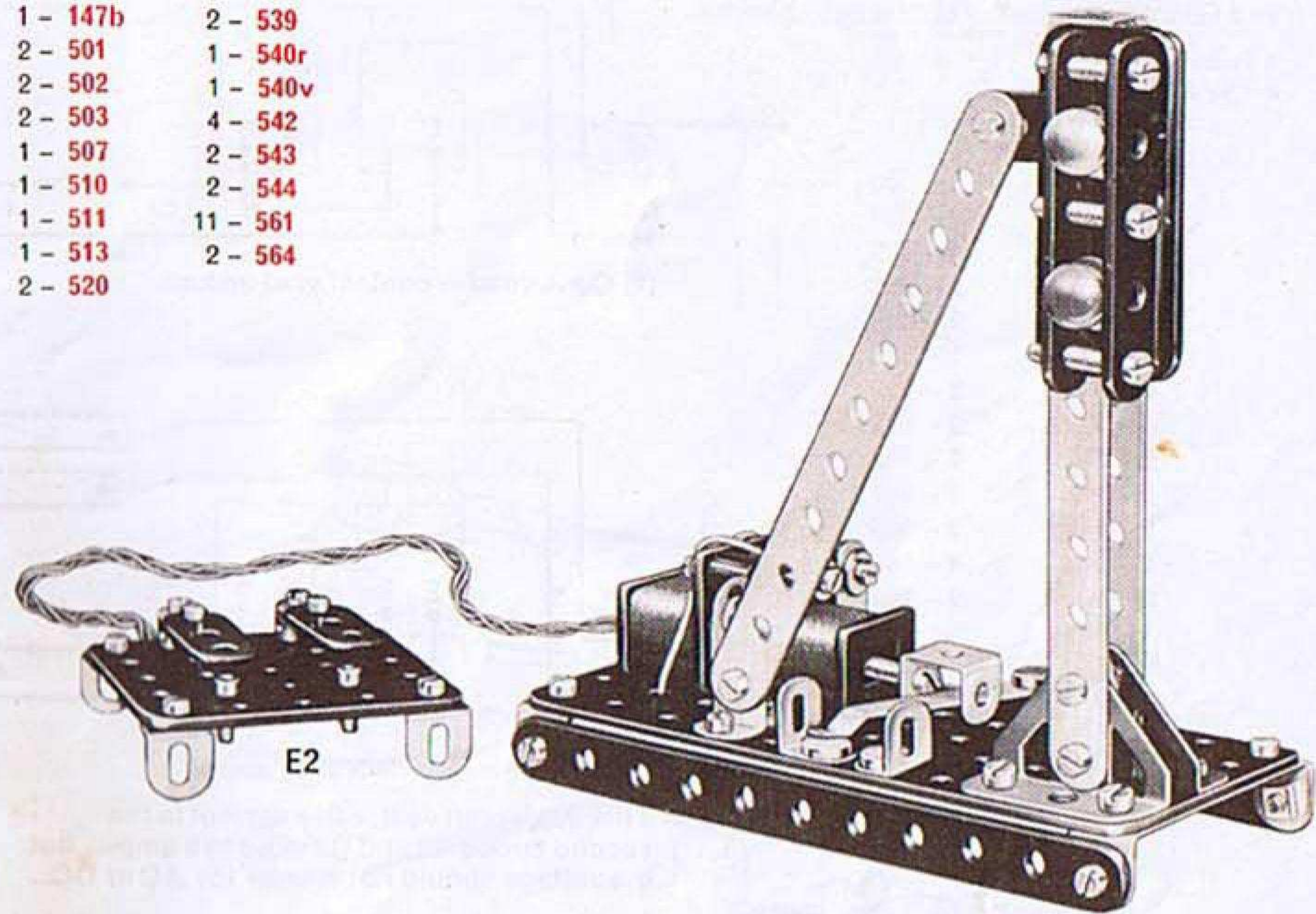
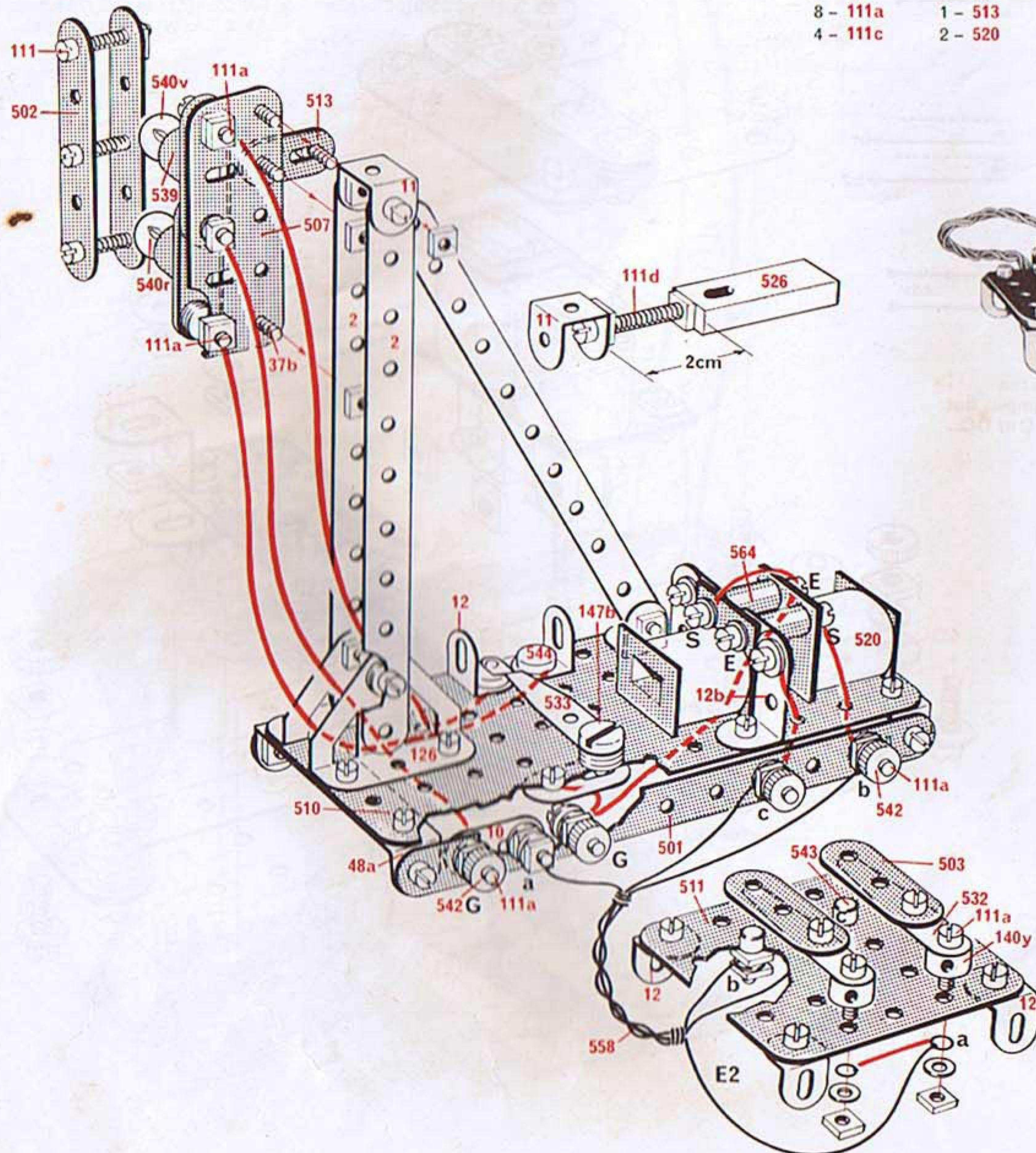

E202-Pole Relay Switch

This is a model of a two-pole relay switch which, when actuated by an electric current fed to terminals G1, switches a second current G2 and G3 from one pair of contacts to another.

4.5v battery.
6-15v AC or DC.

- | | |
|----------|---------|
| 8 - 5 | 1 - 508 |
| 6 - 10 | 2 - 520 |
| 44 - 37a | 4 - 525 |
| 25 - 37b | 2 - 526 |
| 22 - 38 | 2 - 528 |
| 1 - 52 | 1 - 529 |
| 2 - 111 | 2 - 530 |
| 4 - 111a | 2 - 531 |
| 5 - 111c | 2 - 533 |
| 2 - 125 | 4 - 542 |
| 2 - 140y | 2 - 543 |
| 2 - 502 | 4 - 561 |
| 2 - 503 | 2 - 563 |
| 1 - 507 | |

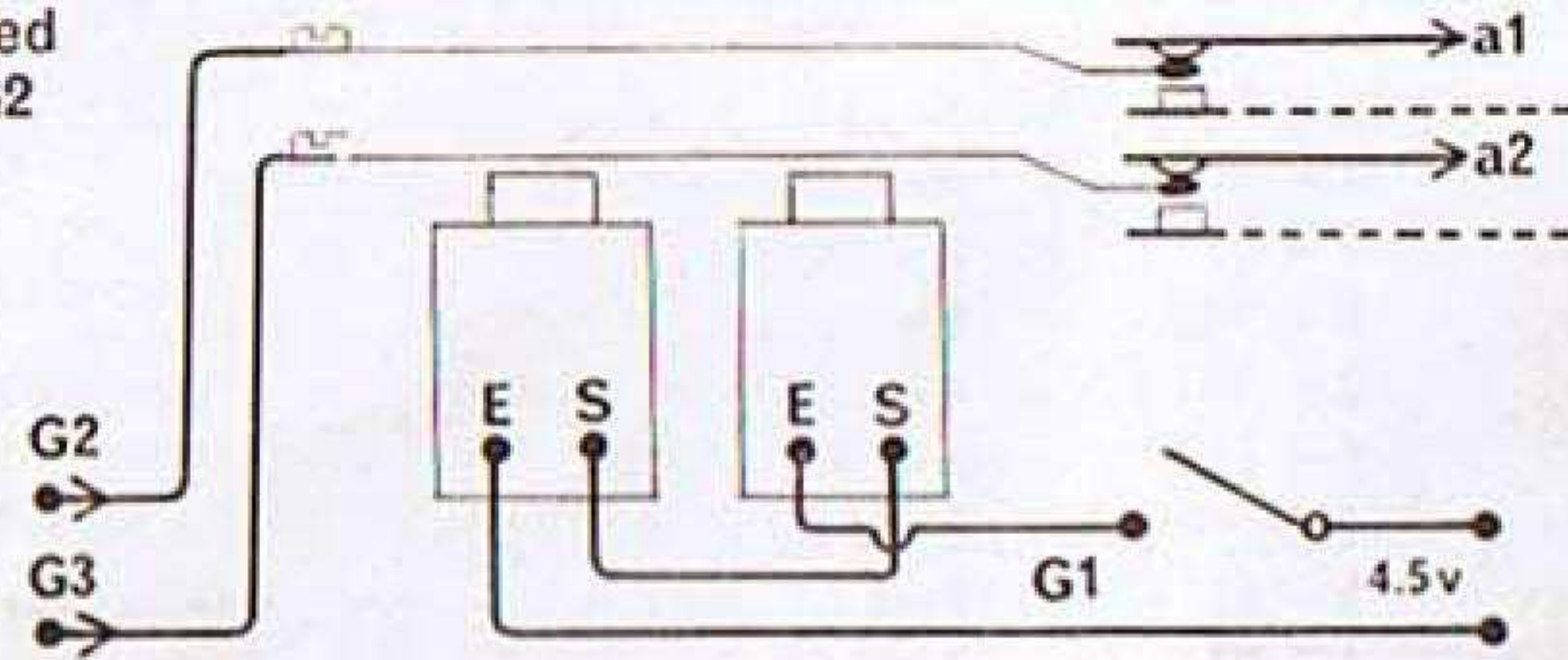

(1) Coils dead — contact at a1 and a2.

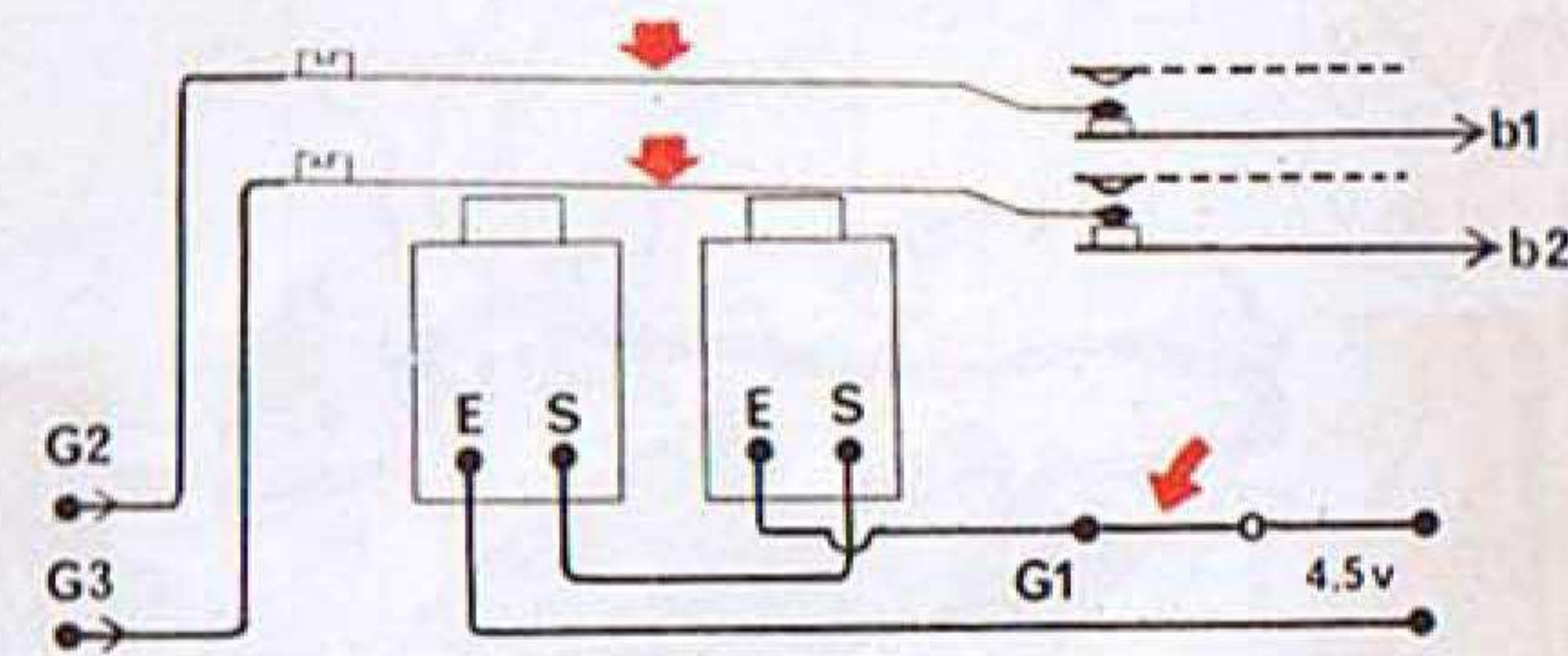

(2) Coils live — contact at b1 and b2.

This model can deal with a current in the second circuit G2 and G3 of up to 5 amps., but the voltage should not exceed 15v AC or DC.

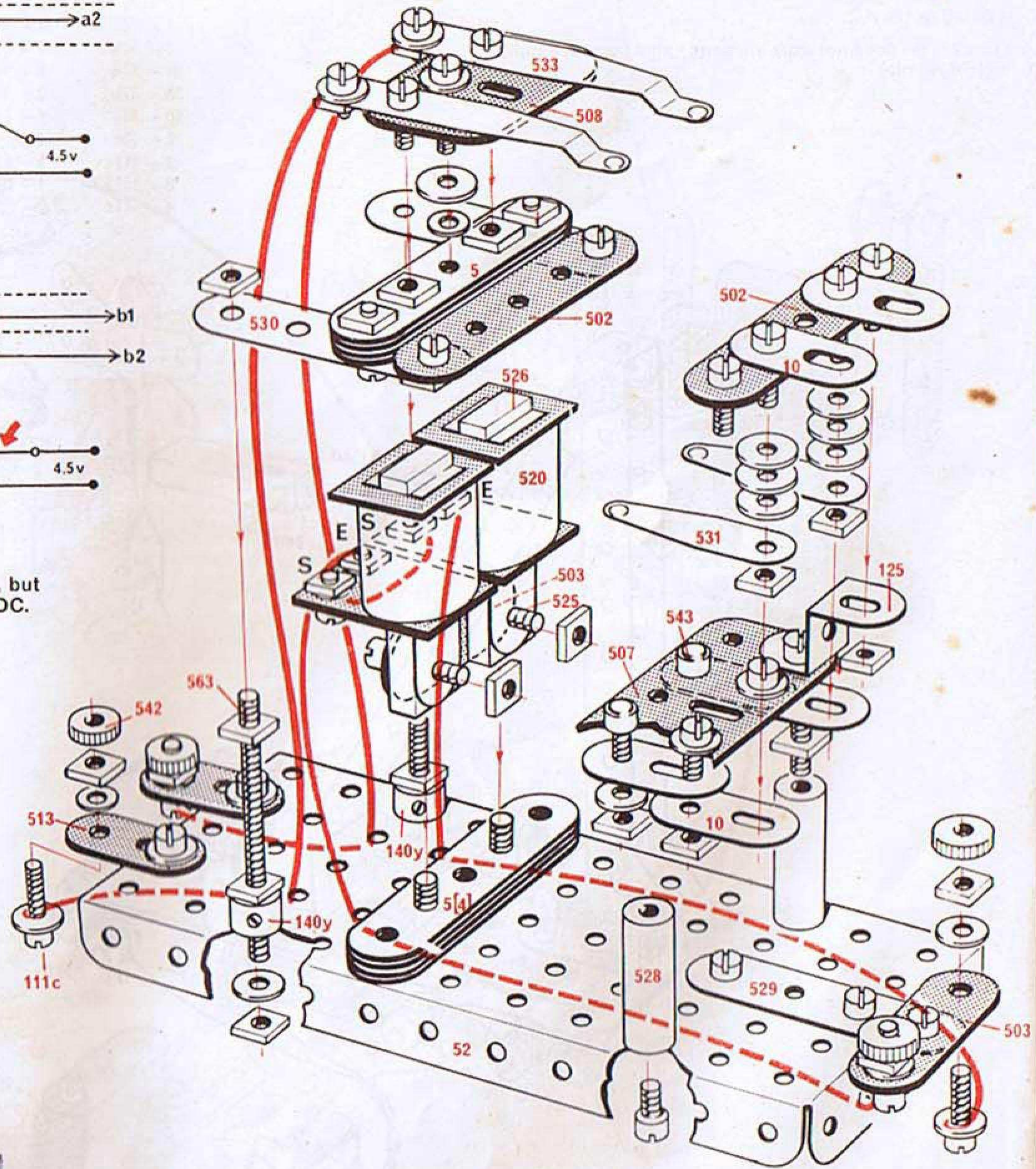
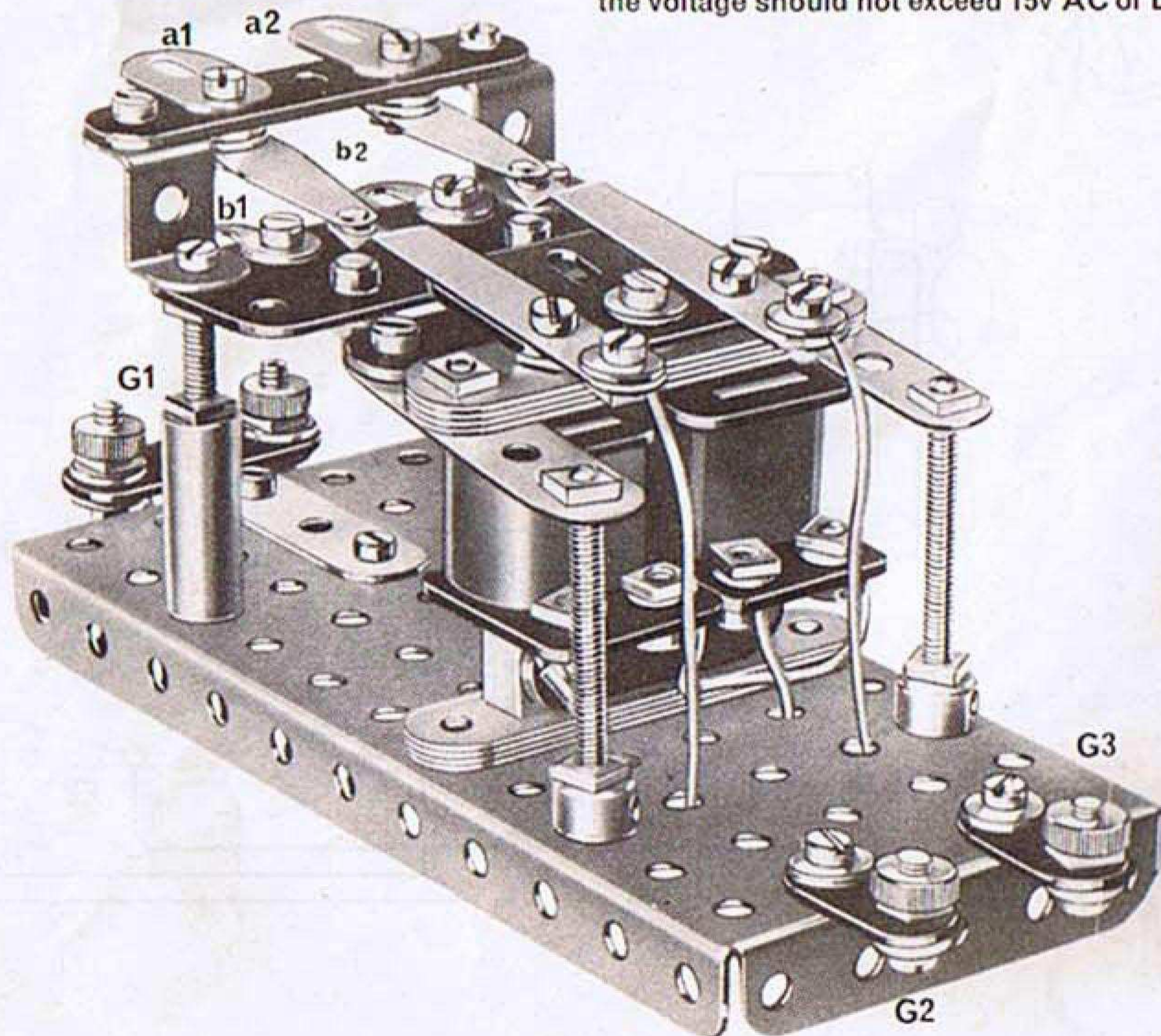

E21 Permanent Magnet Motor with reducing pulley

A very useful low-power motor for driving light Meccano models (model E37 for example).

12v DC only.

The motor will not start by itself unless the Coils are in line with the Magnets (as in the illustration) before it is switched on. Otherwise it is easily started by hand. The motor can be reversed by reversing the current at the terminals (for which switch E3 could be used).

The Wiper Arms 533 should be bent in such a way as to ensure light contact with the commutator formed by the Insulating Bush Wheel 514.

- | | |
|--------|--------|
| 7-5 | 1-140y |
| 2-10 | 1-186a |
| 1-15b | 2-501 |
| 1-19b | 1-511 |
| 1-22 | 1-514 |
| 1-24 | 2-520 |
| 51-37a | 2-525 |
| 33-37b | 2-526 |
| 11-38 | 2-533 |
| 1-52 | 2-537 |
| 1-59 | 2-538 |
| 2-111a | 2-542 |
| 4-111c | 8-544 |
| 1-125 | 1-545 |
| 2-126 | 1-548 |
| 2-126a | 2-561 |

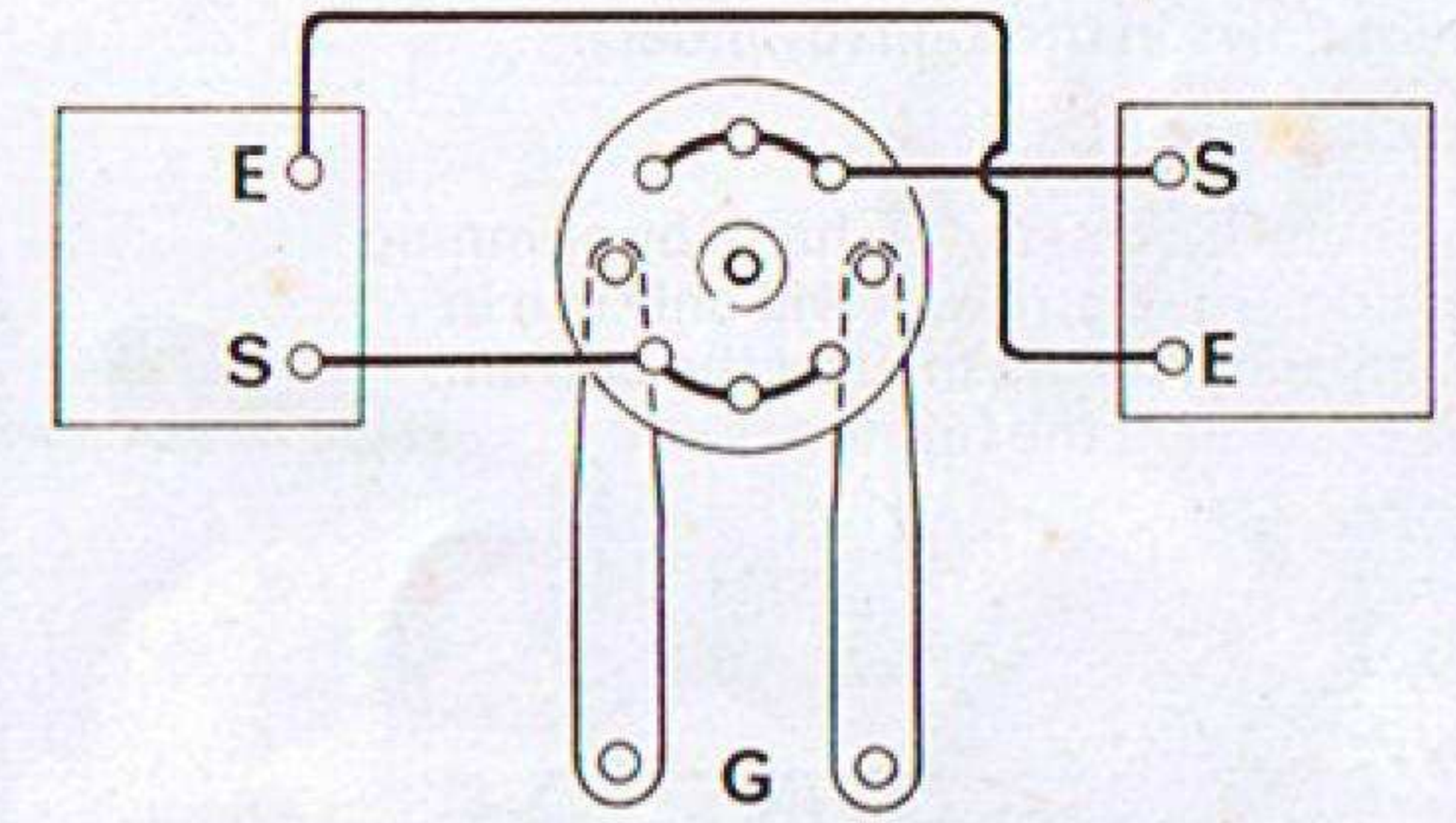

Air gap = thickness of Strip part 5.

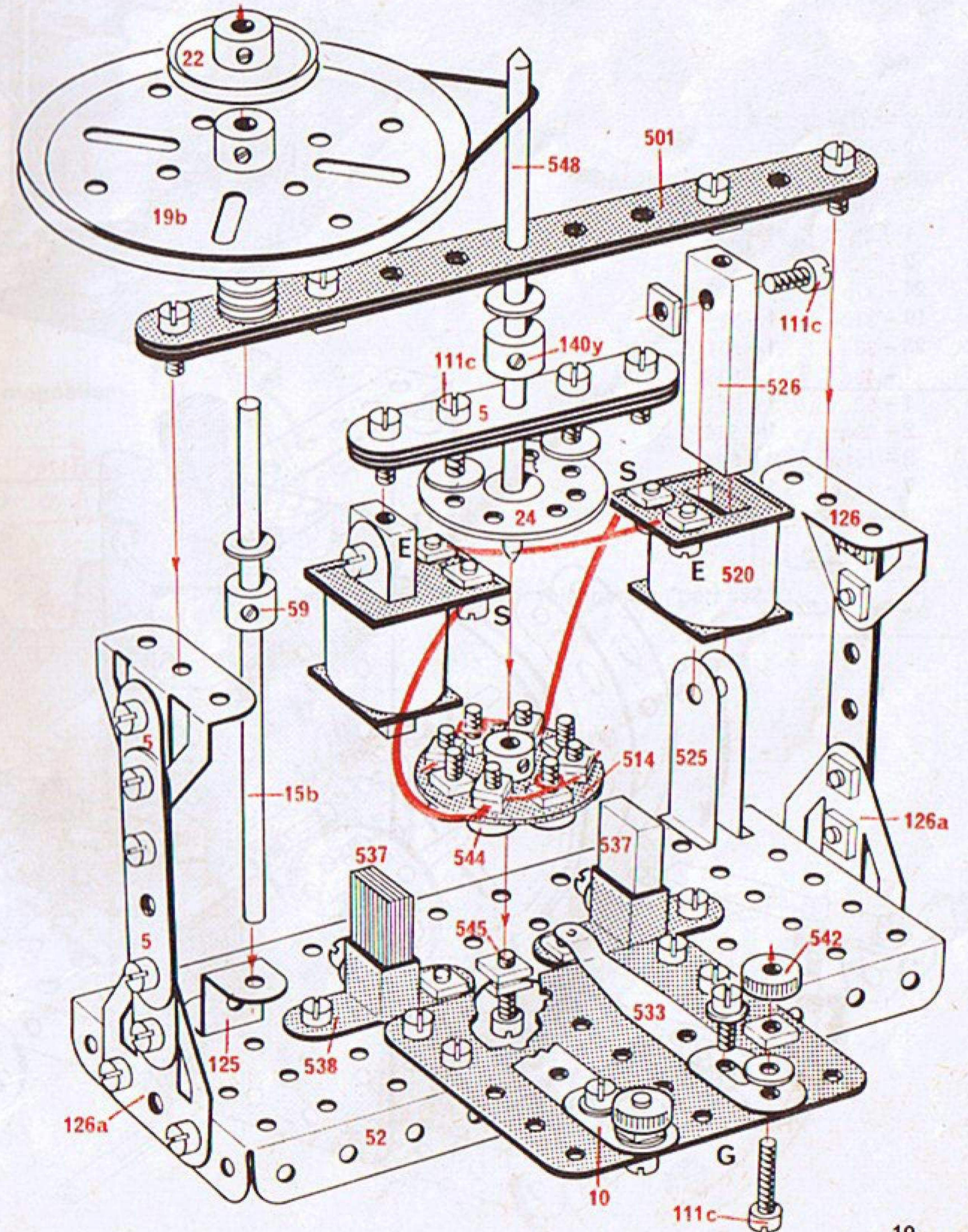
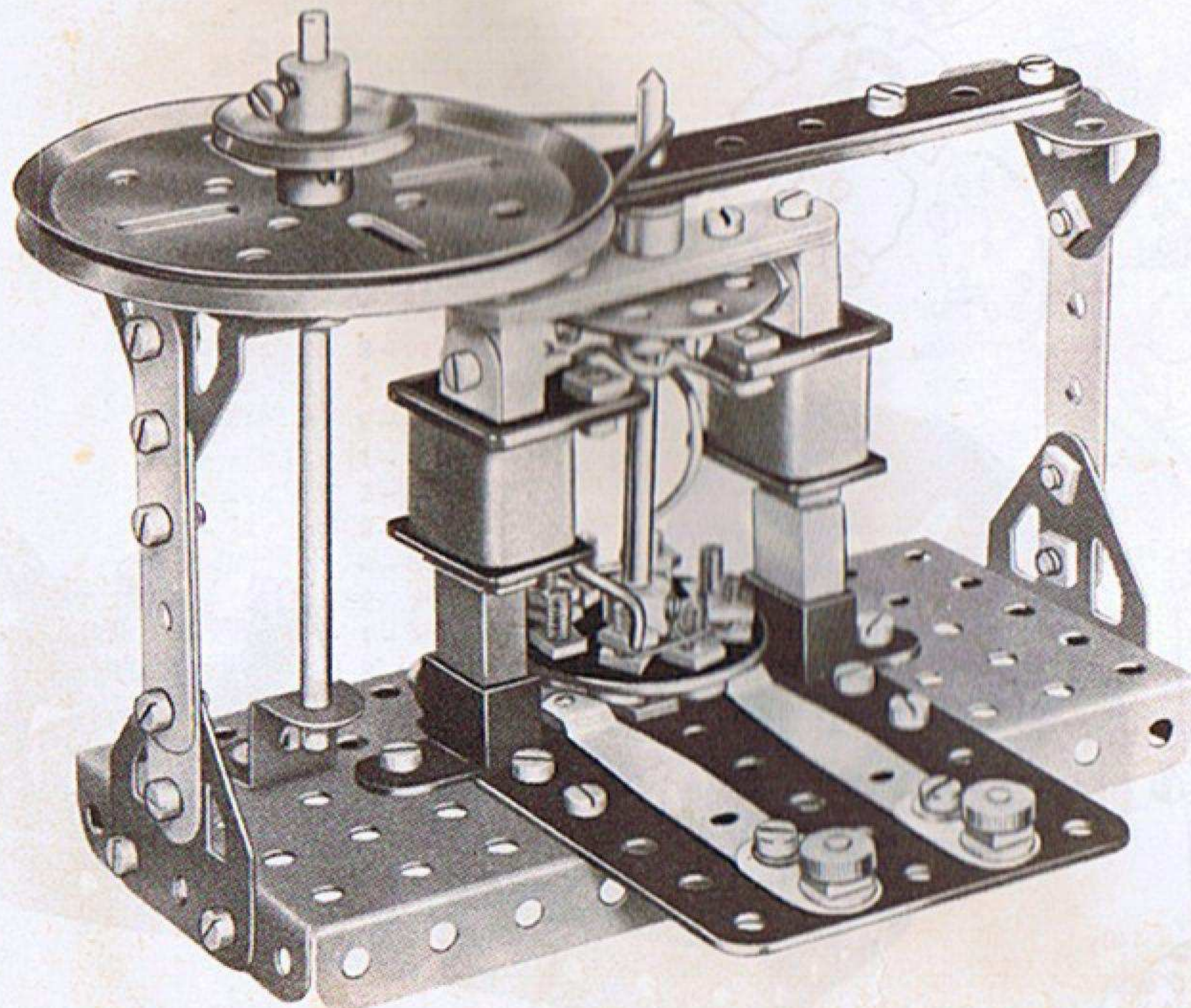
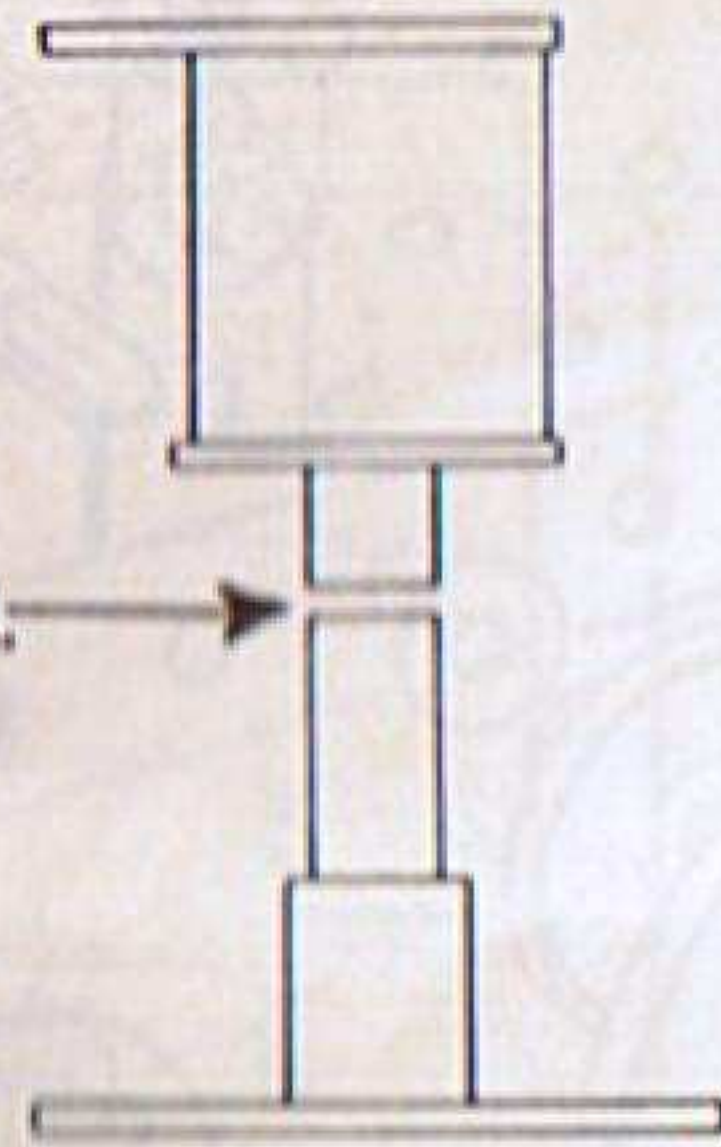

E22 Single Cylinder Vertical Engine

An experimental engine in which movement is induced in the Core, which represents a piston, when current flows in the Coil (cylinder).

12v DC only.

The engine must be started by hand by spinning in the direction of the arrow. It will only run in this direction and if it fails to start the current should be reversed at the terminals.

Air gap = thickness of Wiper Arm 531.

- | | |
|--------|--------|
| 1-2 | 1-126a |
| 1-10 | 2-140y |
| 2-11 | 1-502 |
| 2-12b | 1-503 |
| 1-18a | 1-508 |
| 1-19b | 1-510 |
| 1-24 | 1-518 |
| 2-35 | 1-522 |
| 24-37a | 1-527 |
| 19-37b | 1-529 |
| 28-38 | 1-531 |
| 1-48a | 1-533 |
| 1-52 | 1-537 |
| 2-90a | 1-538 |
| 2-111a | 3-542 |
| 7-111c | 1-555 |
| 1-115 | 2-561 |

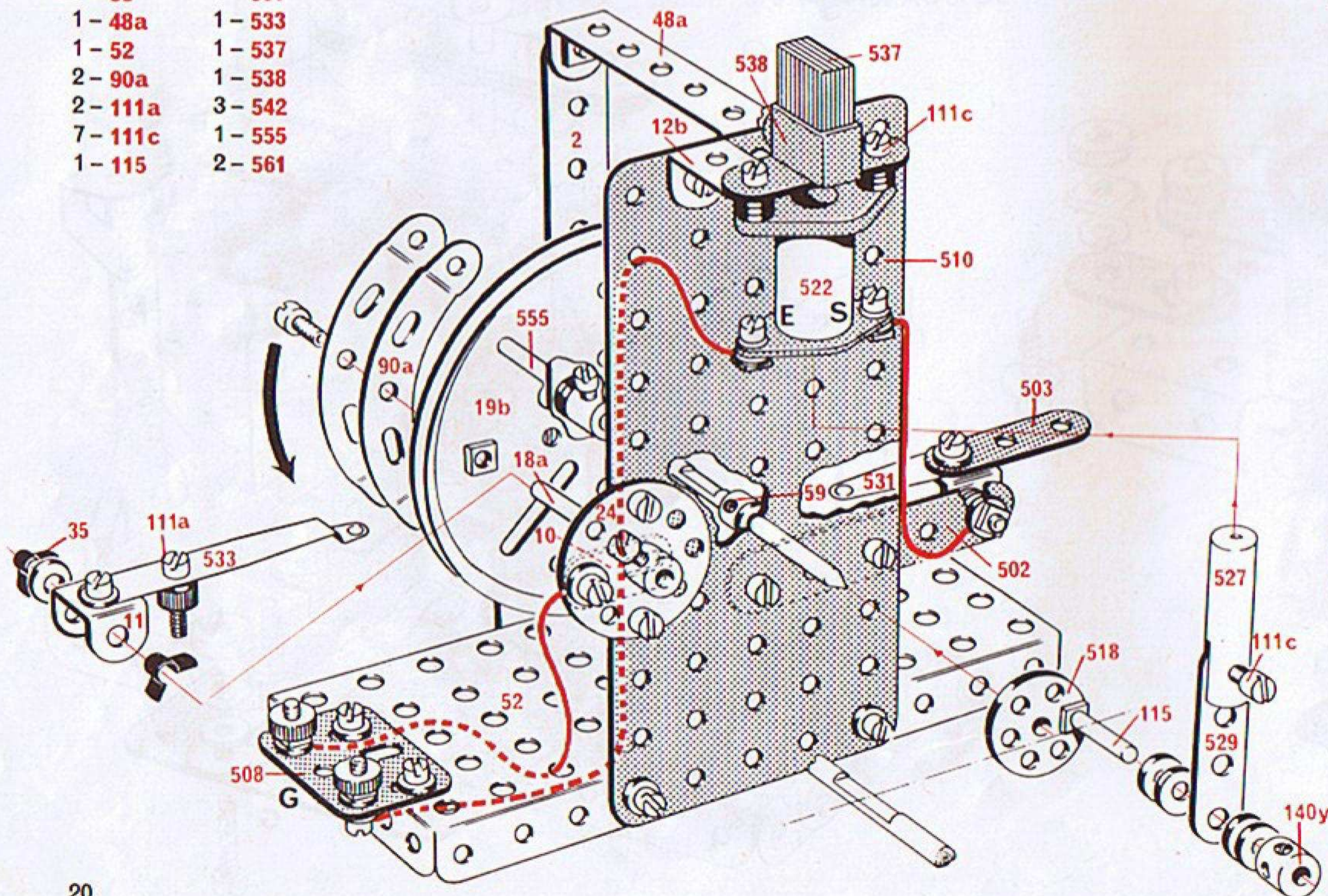
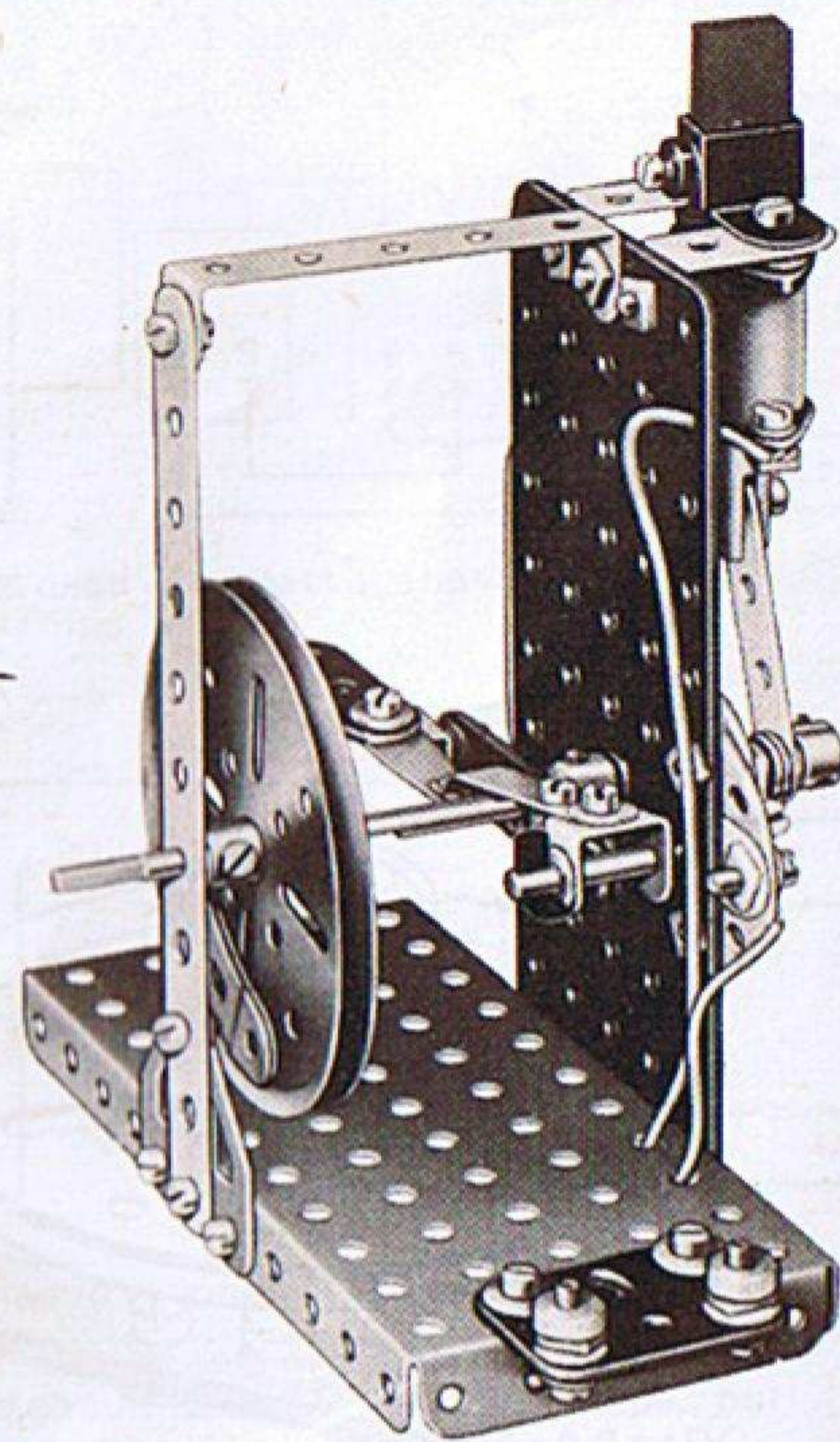

E23 Horizontal Electric Engine

The Magnets are kept in position by their own magnetism.

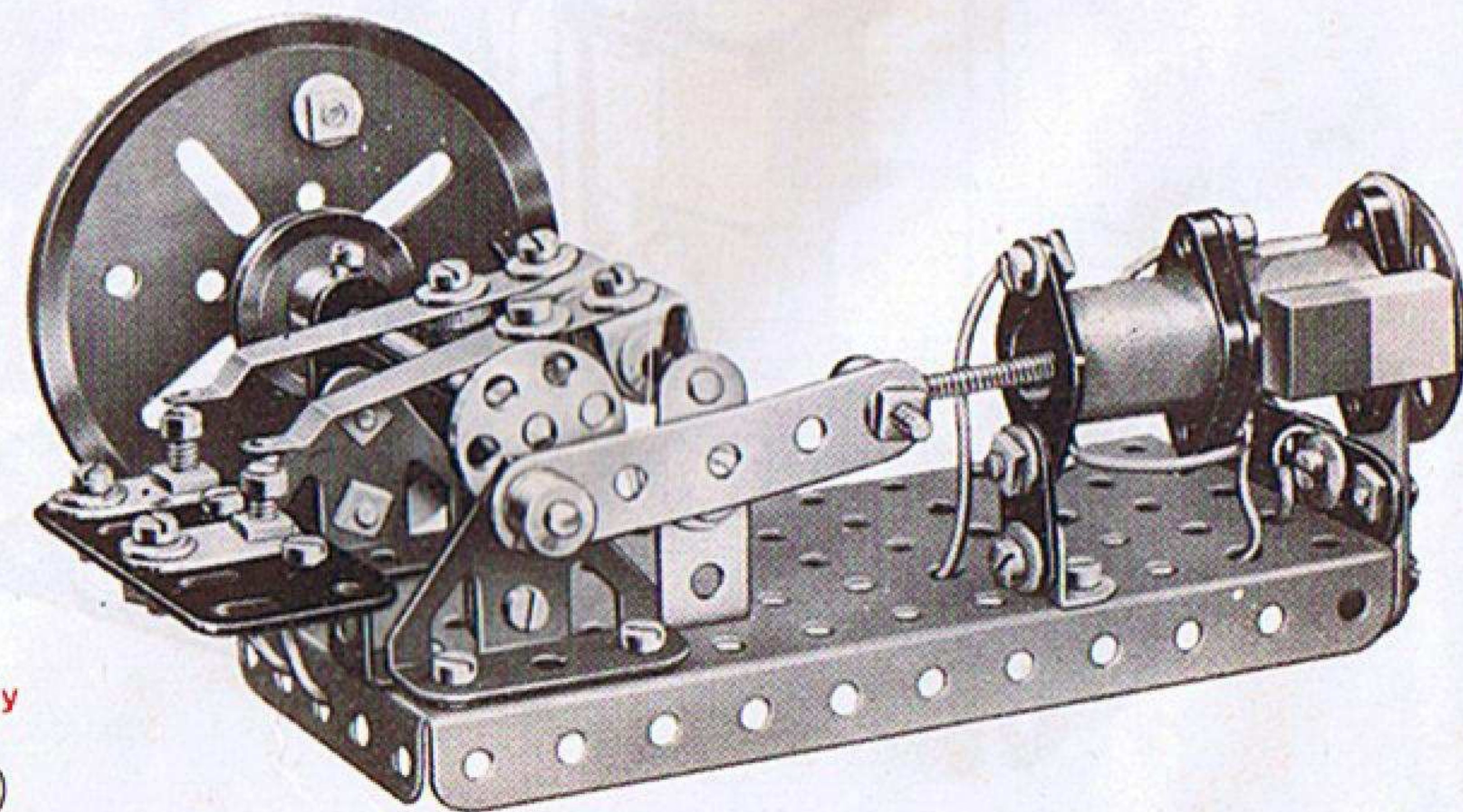
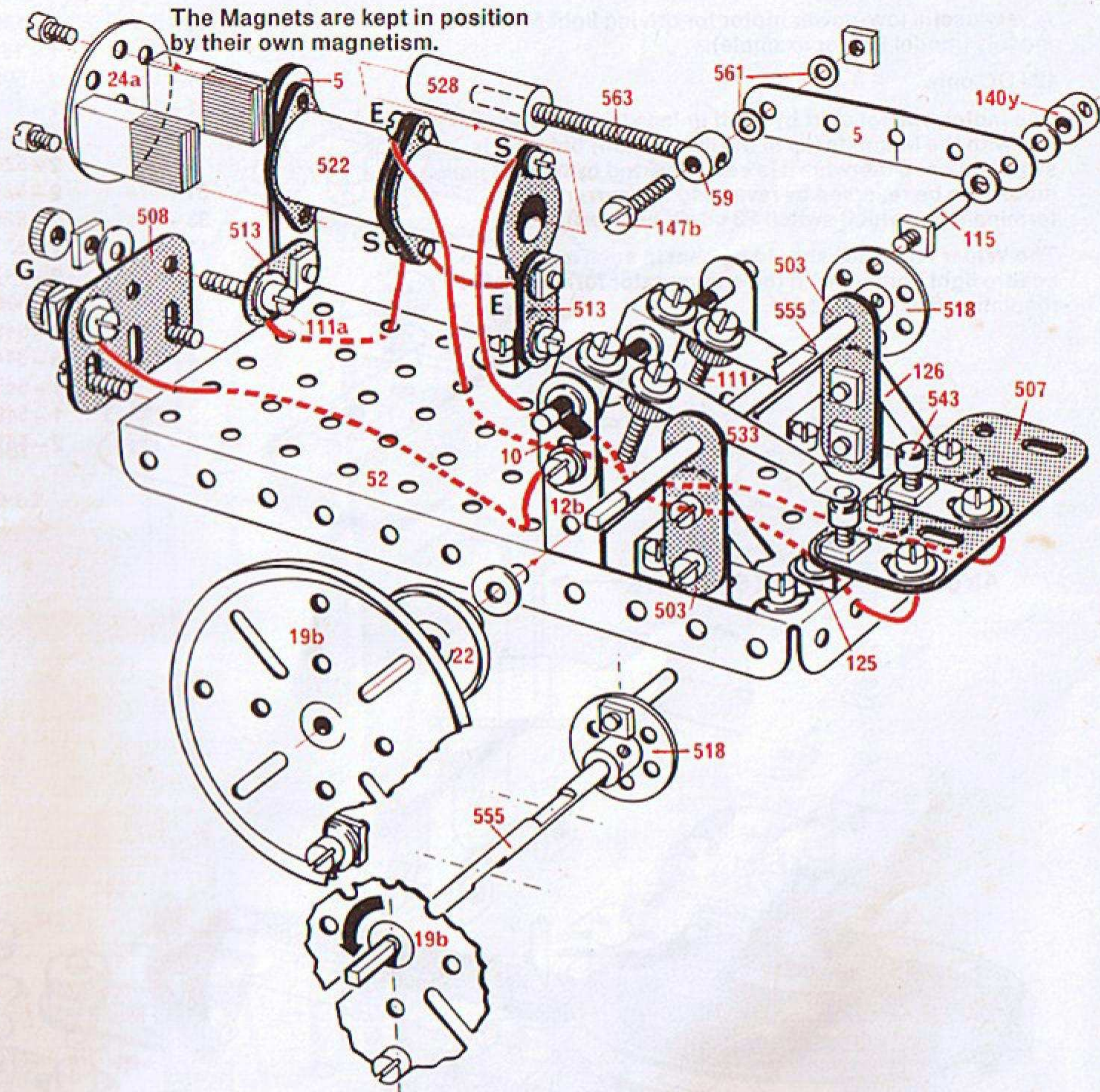

E24 Horizontally-opposed 2-Cylinder Engine

Models E23 and E24 work on the same principle as model E22 but here two Coils are used to give a power stroke in both directions. Two contacts timed by the Rod with Square End 555 direct the current alternately to the two Coils.

12v DC only.

It may be necessary to start the motor by hand in the direction of the arrow. It will only run in this direction and if it fails to start the current should be reversed at the terminals.

- | | |
|----------|---------|
| 2 - 10 | 2 - 503 |
| 2 - 11 | 1 - 507 |
| 8 - 12 | 1 - 508 |
| 2 - 12b | 1 - 510 |
| 1 - 16b | 1 - 511 |
| 1 - 19b | 1 - 518 |
| 2 - 24a | 2 - 522 |
| 4 - 35 | 2 - 527 |
| 47 - 37a | 2 - 529 |
| 33 - 37b | 2 - 533 |
| 33 - 38 | 2 - 537 |
| 2 - 48a | 4 - 542 |
| 1 - 52 | 2 - 543 |
| 1 - 59 | 1 - 555 |
| 1 - 111 | 6 - 561 |
| 4 - 111a | 2 - 563 |
| 3 - 111c | |

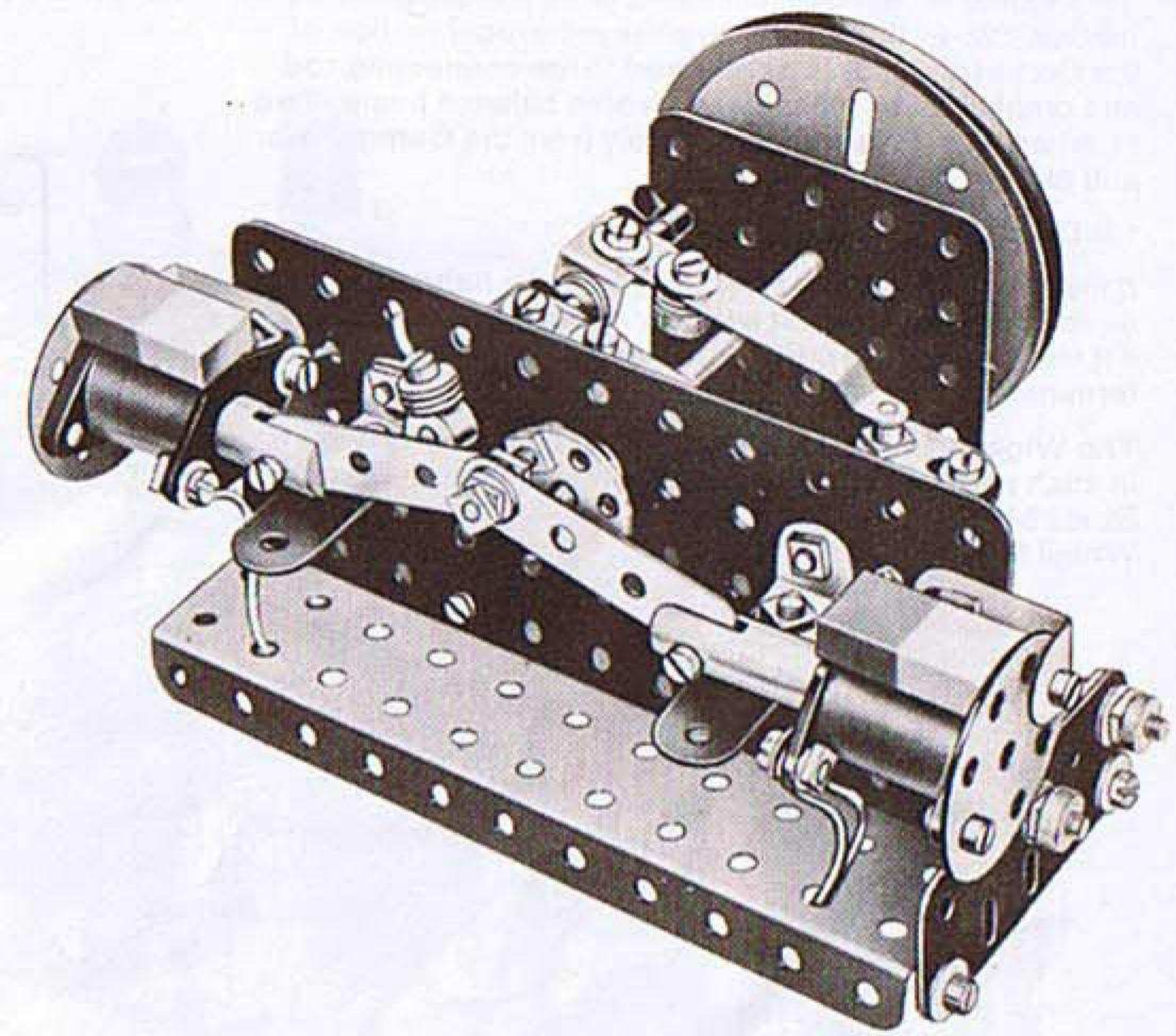
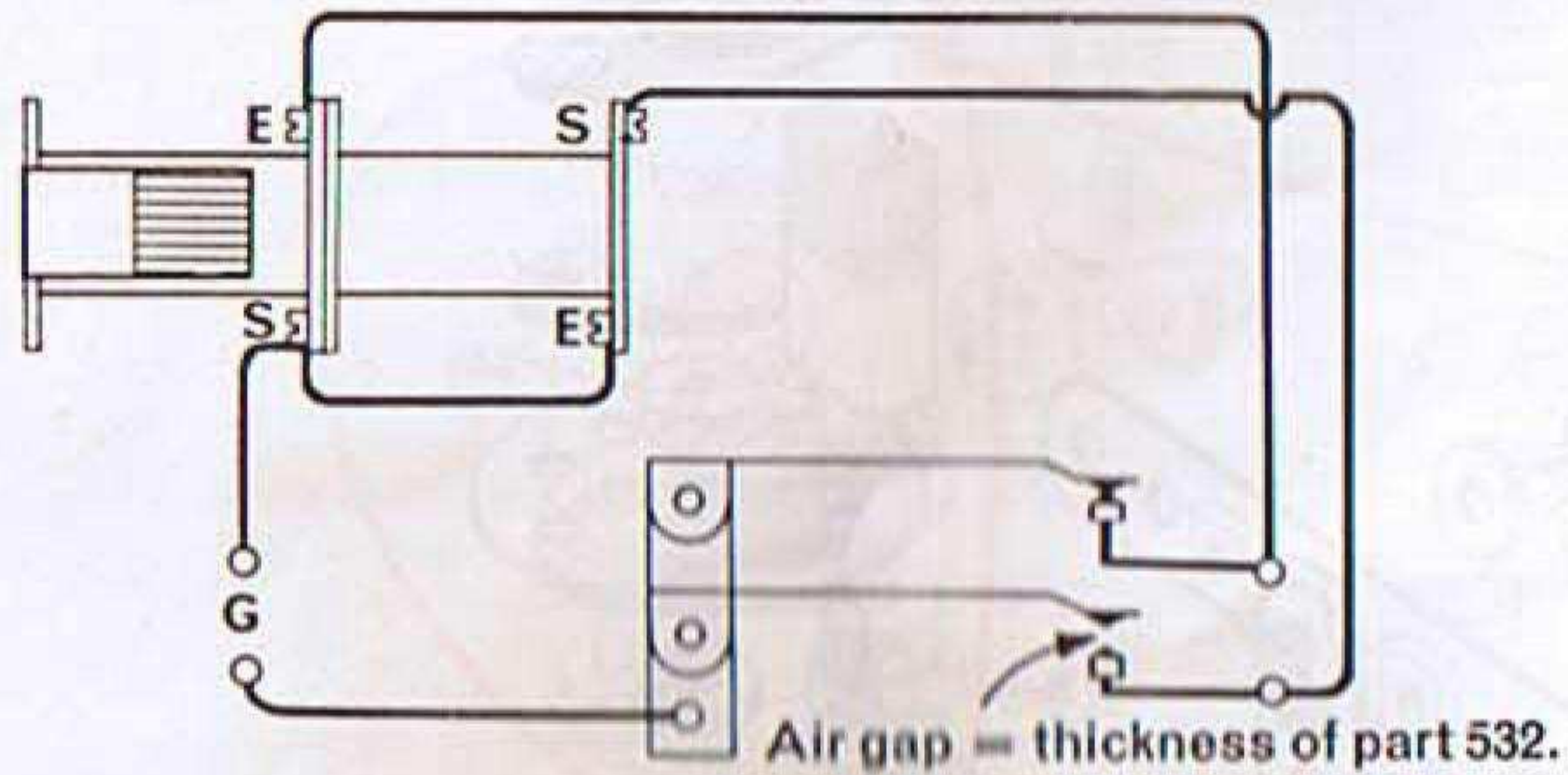

The Magnets are kept in position by their own magnetism.

- | | |
|----------|----------|
| 3 - 5 | 2 - 126 |
| 4 - 10 | 1 - 140y |
| 2 - 11 | 1 - 147b |
| 2 - 12b | 2 - 503 |
| 1 - 19b | 1 - 507 |
| 1 - 22 | 1 - 508 |
| 1 - 24a | 2 - 513 |
| 3 - 35 | 1 - 518 |
| 37 - 37a | 2 - 522 |
| 33 - 37b | 1 - 528 |
| 28 - 38 | 2 - 533 |
| 1 - 52 | 2 - 537 |
| 1 - 59 | 4 - 542 |
| 2 - 111 | 2 - 543 |
| 2 - 111a | 1 - 555 |
| 1 - 111c | 3 - 561 |
| 1 - 115 | 1 - 563 |
| 2 - 125 | |

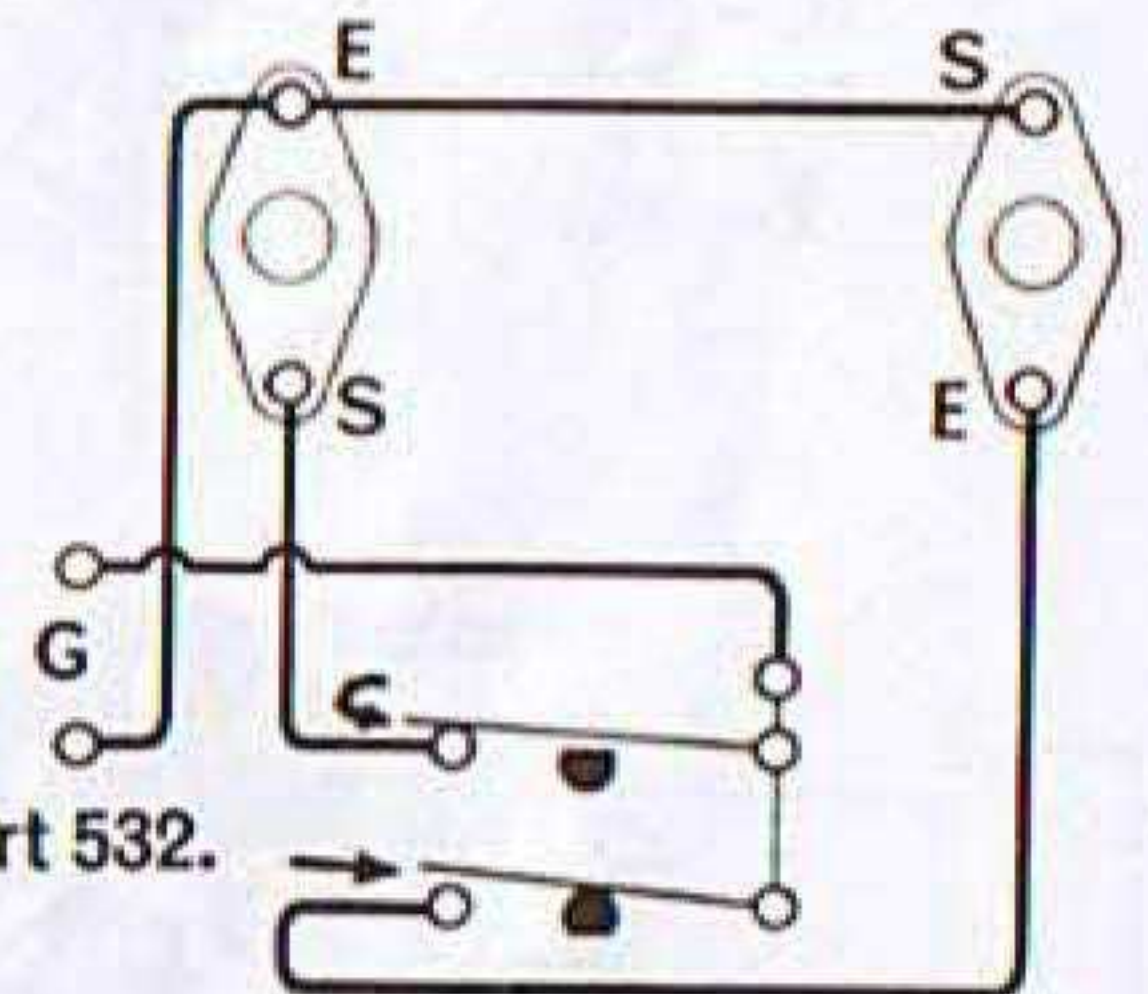
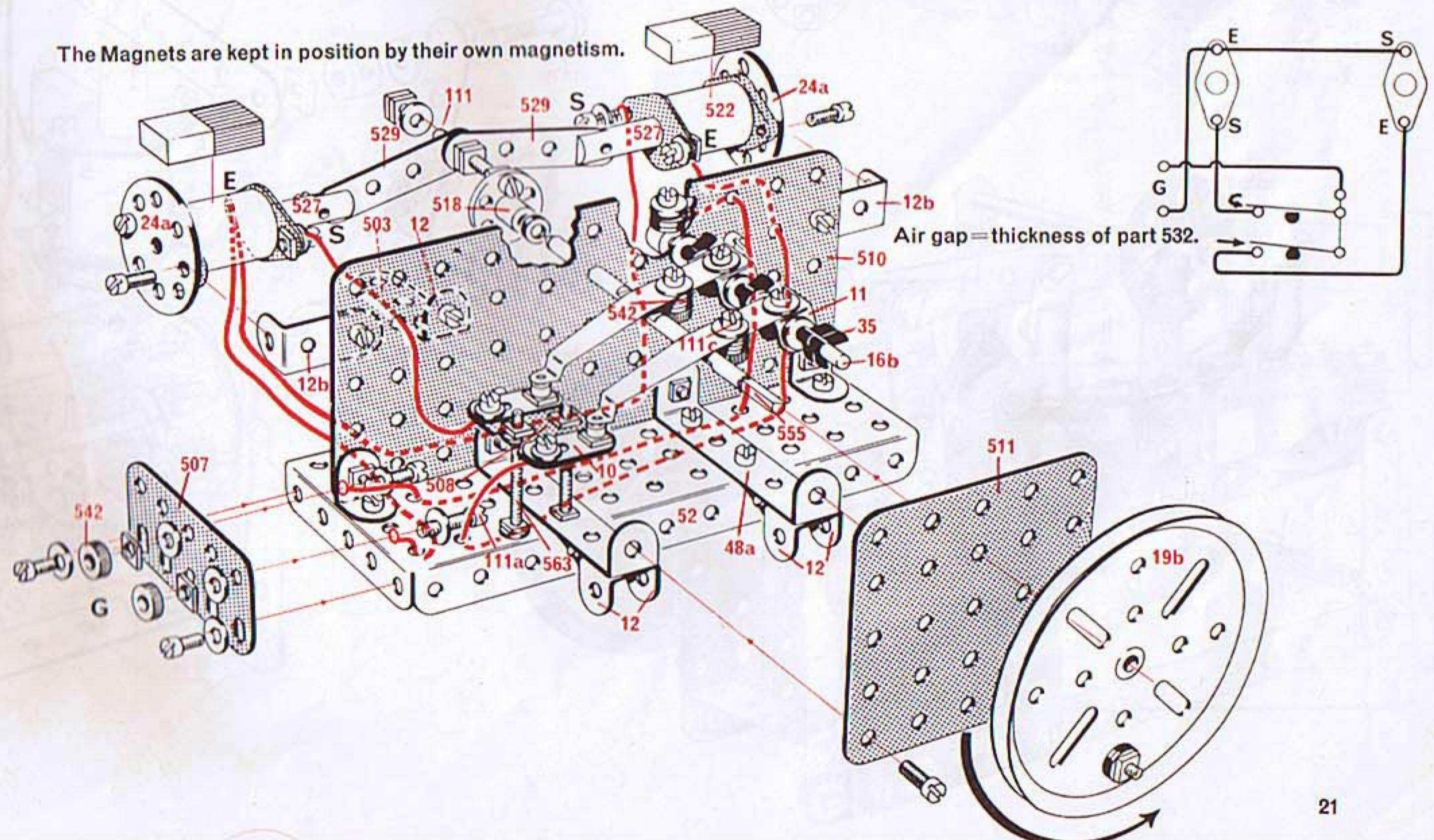

E25 Beam Engine

This model is based on the same electrical principle as models E22-24 but in this case the reciprocal motion of the Cores (pistons) is transferred to the connecting rod and crankshaft by means of a pivoted balance beam. Two brushes pick up current alternately from the Commutator and direct it to the Coils.

12v DC only.

It may be necessary to start the engine by hand in the direction of the arrow. It will only run in this direction and if it fails to start the current should be reversed at the terminals.

The Wiper Arms 533 forming the brushes should be bent in such a way as to ensure light contact with the Contact Studs 544 on the commutator formed by Insulating Bush Wheel 514.

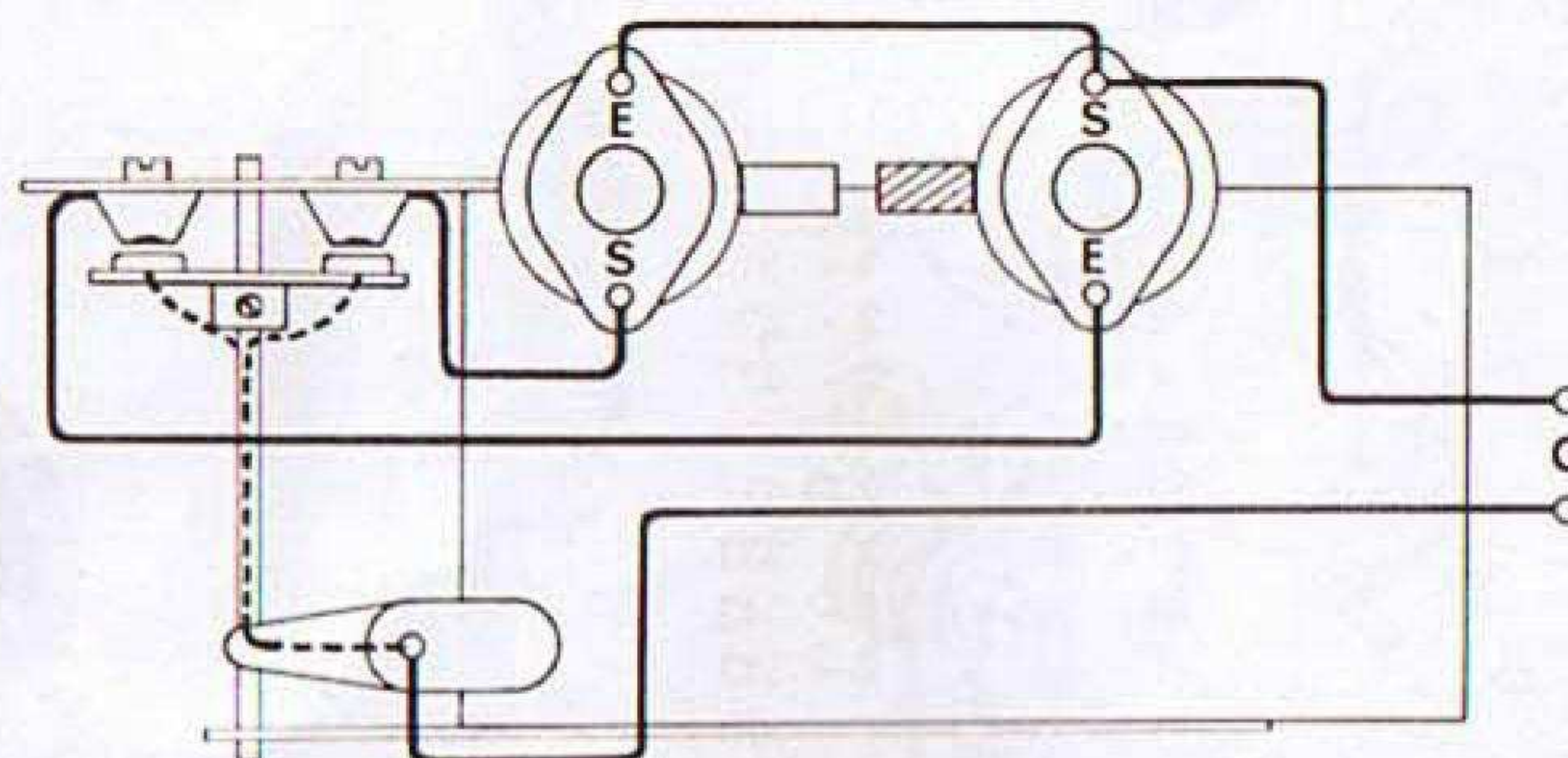

- | | | |
|----------|----------|---------|
| 2 - 2 | 1 - 52 | 1 - 513 |
| 4 - 5 | 1 - 59 | 1 - 514 |
| 5 - 10 | 2 - 90a | 1 - 518 |
| 1 - 15b | 3 - 111a | 2 - 522 |
| 1 - 16 | 6 - 111c | 2 - 527 |
| 1 - 19b | 1 - 115 | 1 - 529 |
| 1 - 22 | 1 - 126 | 1 - 531 |
| 1 - 24 | 1 - 126a | 1 - 533 |
| 2 - 24a | 1 - 140y | 1 - 534 |
| 58 - 37a | 1 - 147b | 2 - 537 |
| 40 - 37b | 1 - 508 | 4 - 542 |
| 31 - 38 | 1 - 510 | 8 - 544 |
| 2 - 48a | 1 - 511 | 4 - 561 |

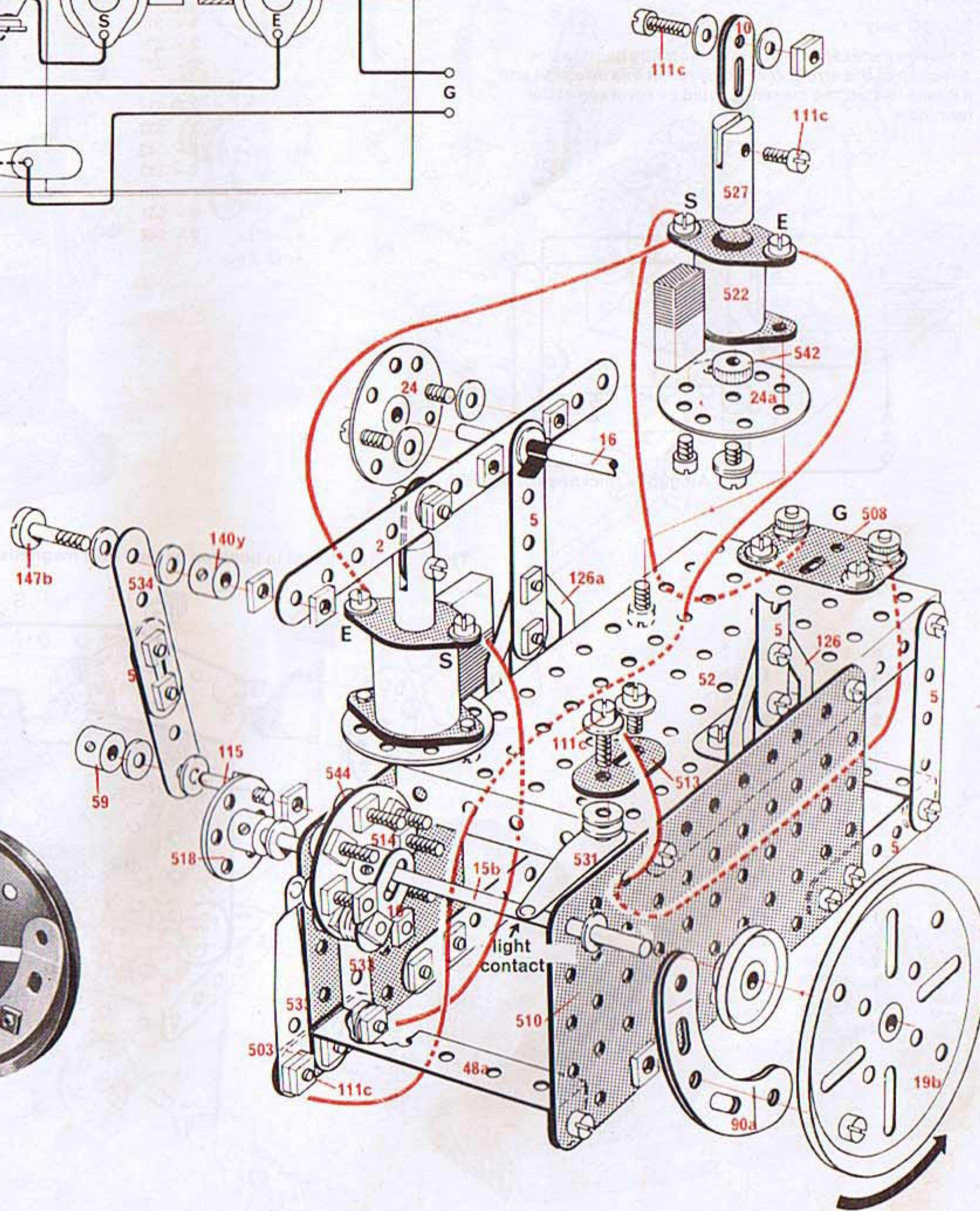
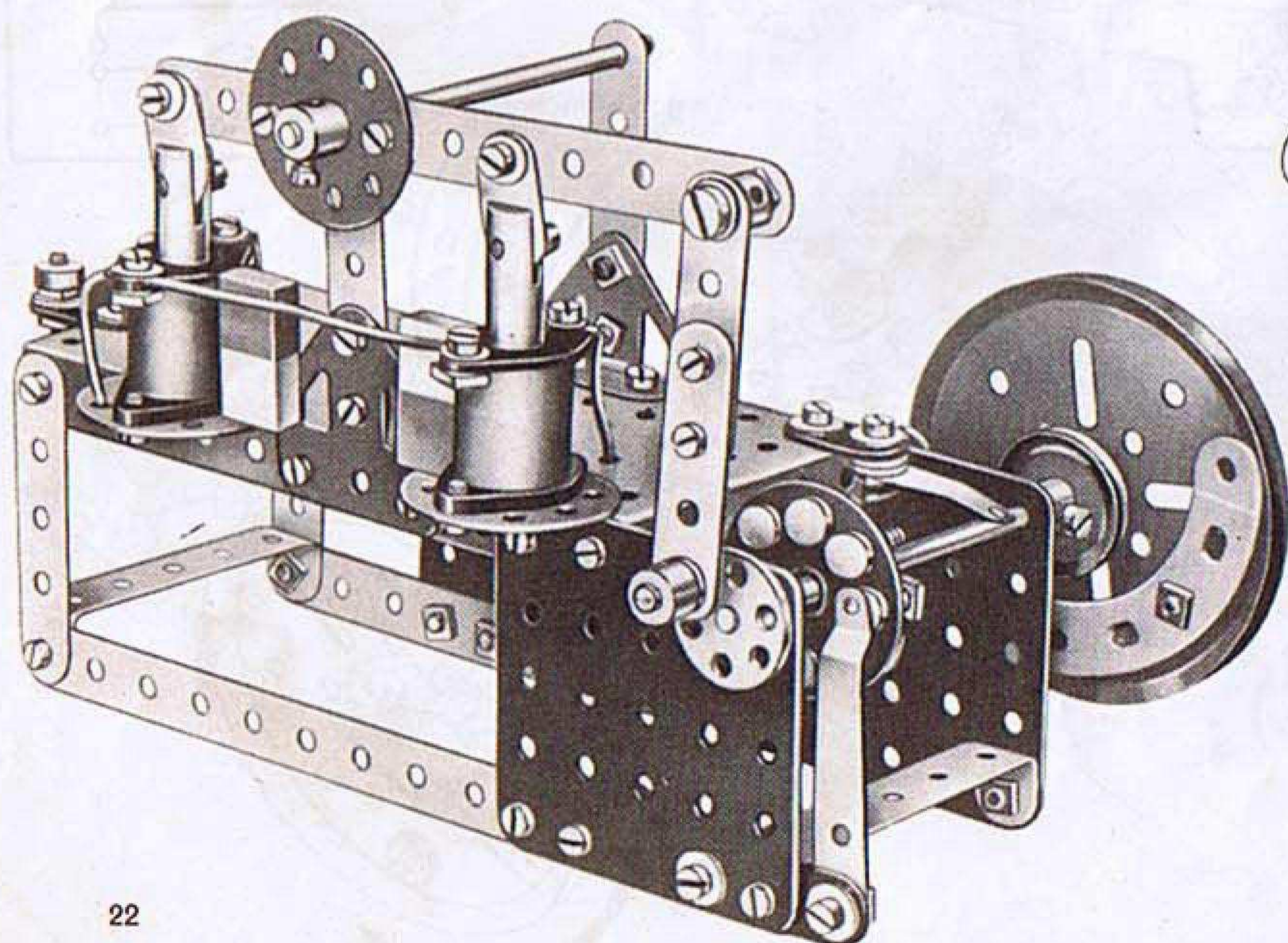
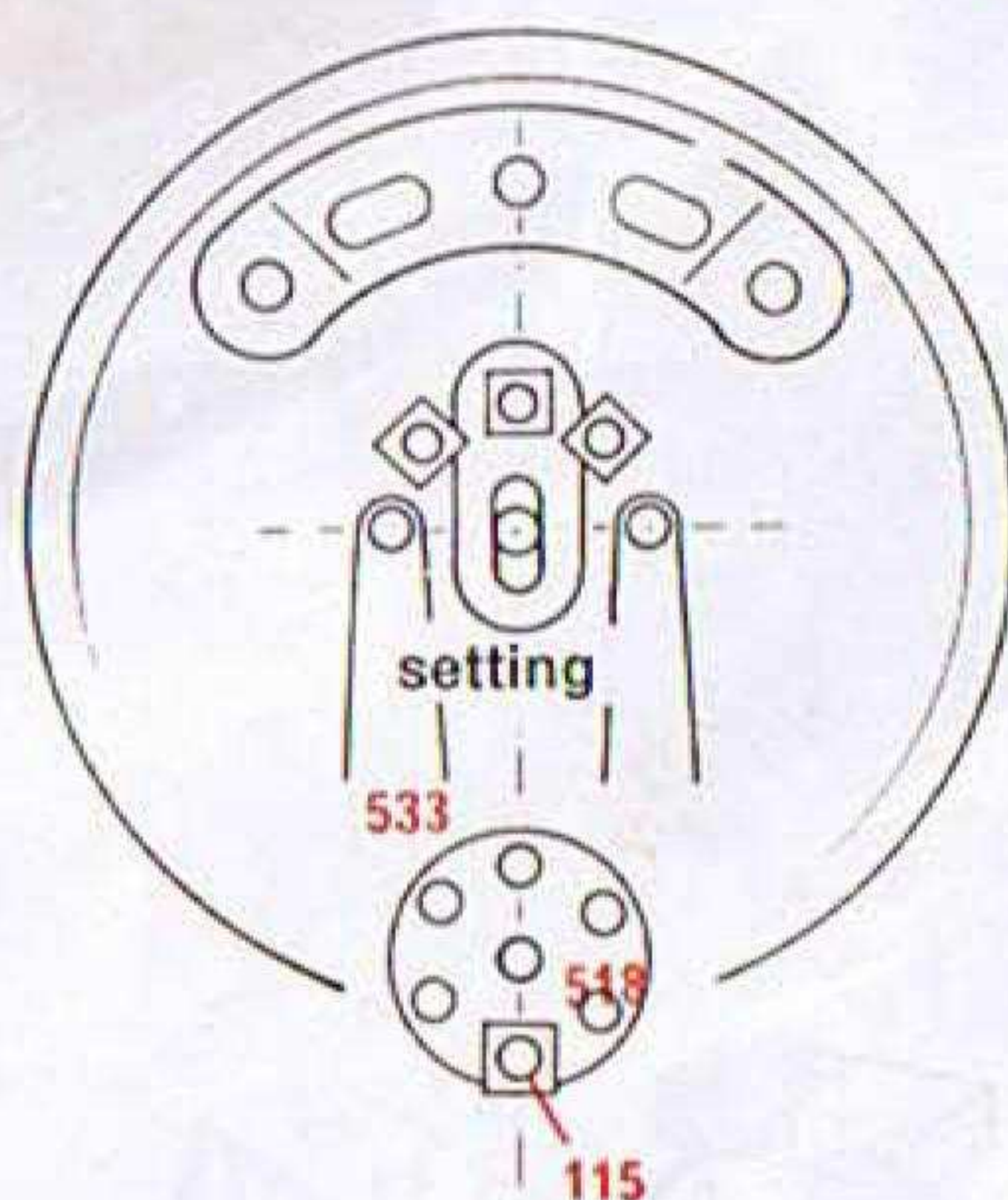

E26 Circuit Breaker with Warning Light

A safety device, taking the place of a fuse, which automatically breaks the circuit in which it is used when the current exceeds a certain voltage or when there is a short-circuit. When the circuit is broken the warning light comes on. It must always be connected in series with the circuit it is protecting, i.e. a Meccano Motor.

Flexible Strip 530 must be bent before assembly in such a way that when the circuit is broken it will spring upwards and bring the bolthead into contact with the boss of Insulating Bush Wheel 518.

4.5v battery.

6-15v AC or DC.

- | | |
|--------|--------|
| 2-2 | 2-190 |
| 5-5 | 1-508 |
| 2-10 | 1-510 |
| 1-11 | 1-511 |
| 5-12 | 1-514 |
| 1-12c | 1-518 |
| 1-17 | 1-522 |
| 1-18a | 1-527 |
| 40-37a | 2-528 |
| 39-37b | 2-529 |
| 35-38 | 1-530 |
| 2-48a | 2-531 |
| 1-59 | 2-534 |
| 1-111 | 1-539 |
| 6-111a | 1-540r |
| 4-111c | 4-542 |
| 1-120b | 3-561 |
| 1-126 | 1-563 |
| 2-140y | 2-564 |

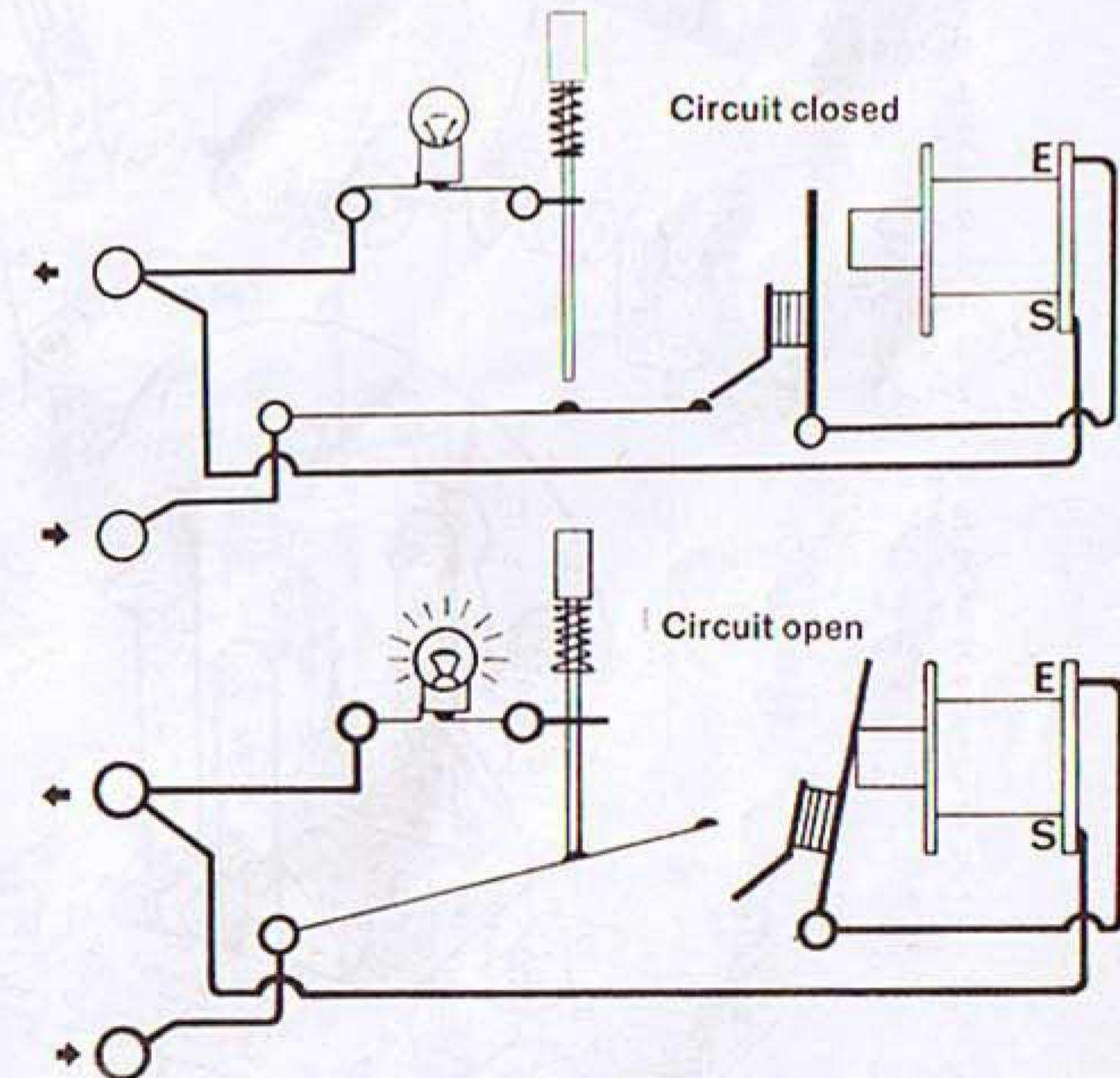
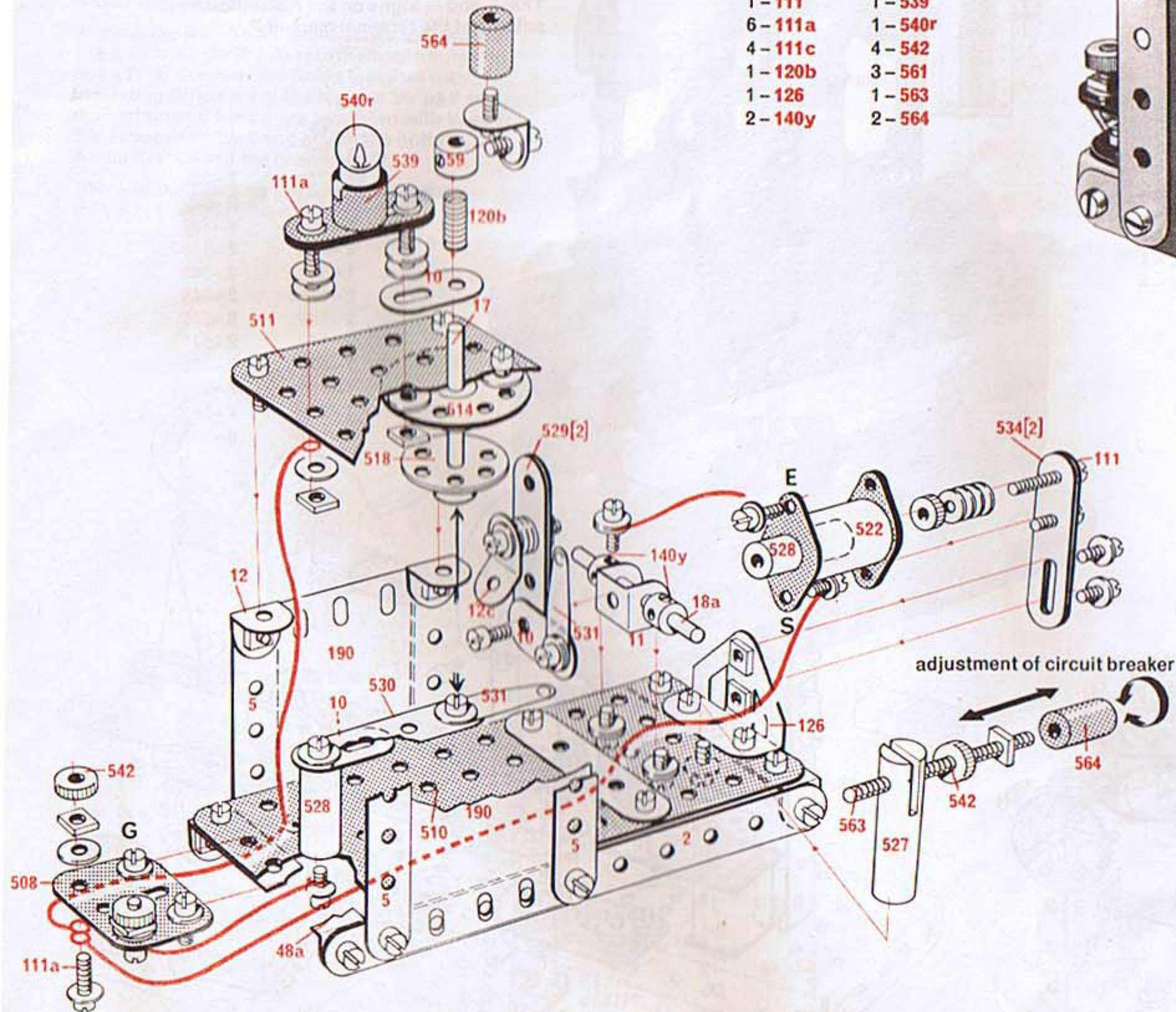
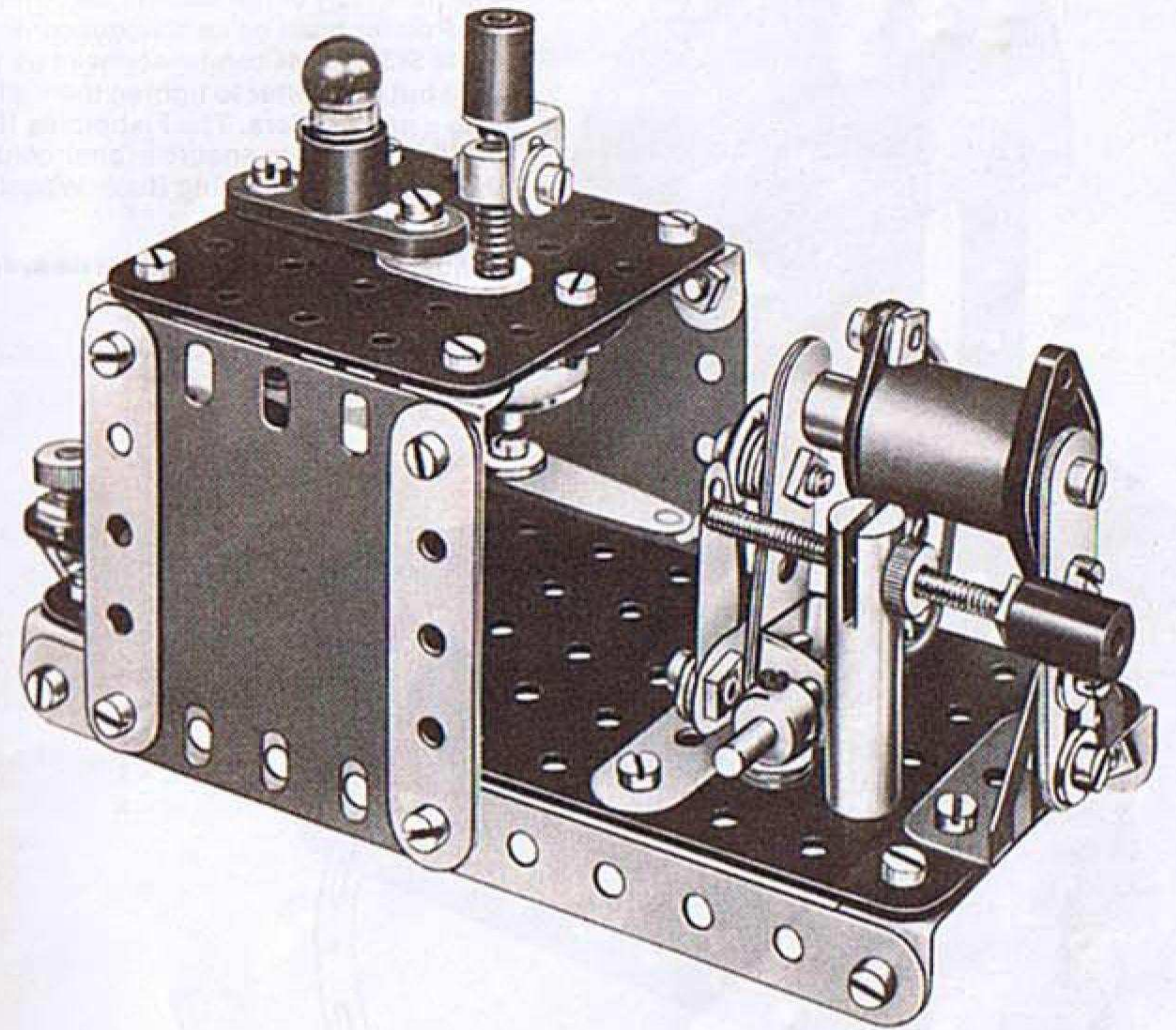

E27 Universal Dynamometer Voltmeter

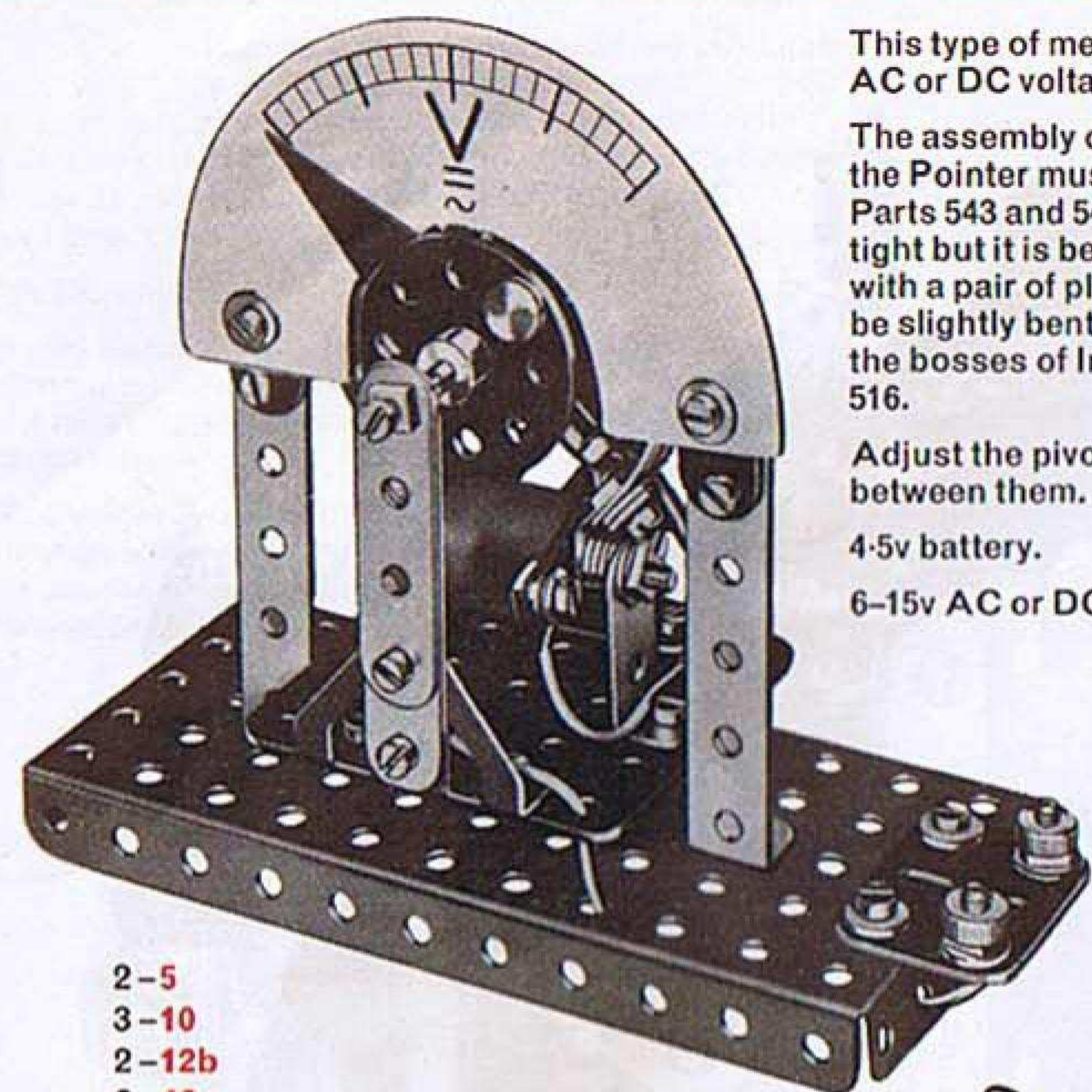

This type of meter is used to measure either AC or DC voltages.

The assembly of the moving part that carries the Pointer must be carried out carefully. Parts 543 and 544 can be screwed up finger tight but it is better to tighten them a little more with a pair of pliers. The Fishplates 10 should be slightly bent to ensure proper contact with the bosses of Insulating Bush Wheels 514 and 516.

Adjust the pivots so that the axle swings freely between them.

4-5v battery.

6-15v AC or DC.

- 2-5
- 3-10
- 2-12b
- 2-12c
- 30-37a
- 26-37b
- 22-38
- 2-48a
- 1-52
- 1-59
- 1-111
- 2-111a
- 1-111d
- 2-126
- 2-140y
- 2-215
- 1-503
- 1-508
- 1-511
- 2-513
- 1-514
- 1-516
- 2-522
- 2-528
- 1-511
- 2-529
- 2-542
- 2-543
- 7-544
- 2-545
- 2-550
- 1-560h
- 1-560k
- 2-561
- 1-563
- 2-564

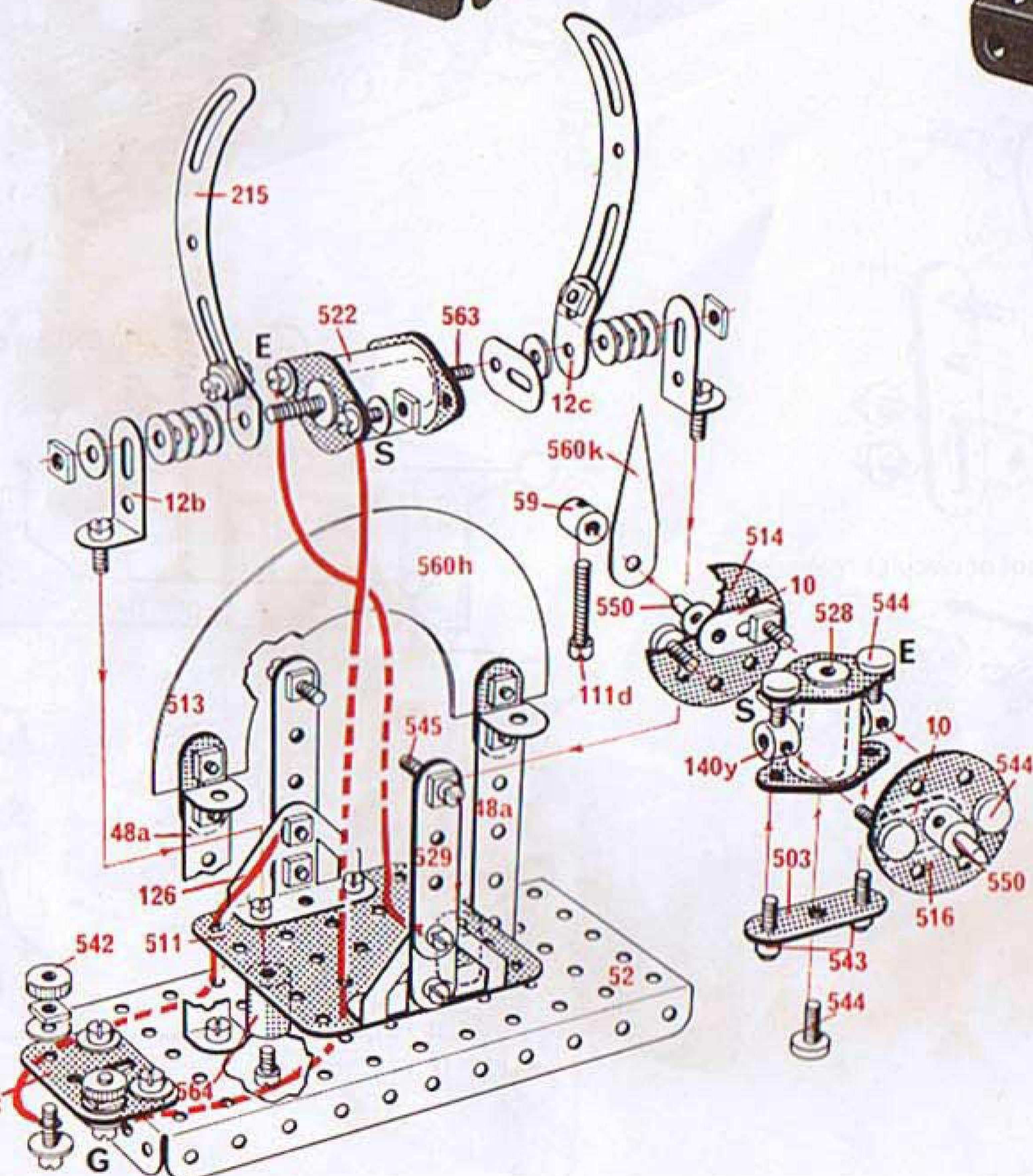

E28 DC Moving Coil Voltmeter

This type of meter is used to measure DC voltages or currents only.

The assembly of the moving part that carries the Pointer must be carried out carefully. Parts 543 and 433 may be screwed up finger tight but it is better to tighten them a little more with a pair of pliers. The Fishplates 10 should be slightly bent to ensure proper contact with the bosses of Insulating Bush Wheels 514 and 516.

Adjust the pivots so that the axle swings freely between them.

4-5v battery.

6-12v DC only.

The + and - signs on the dial indicate the polarity of the terminal marked P.

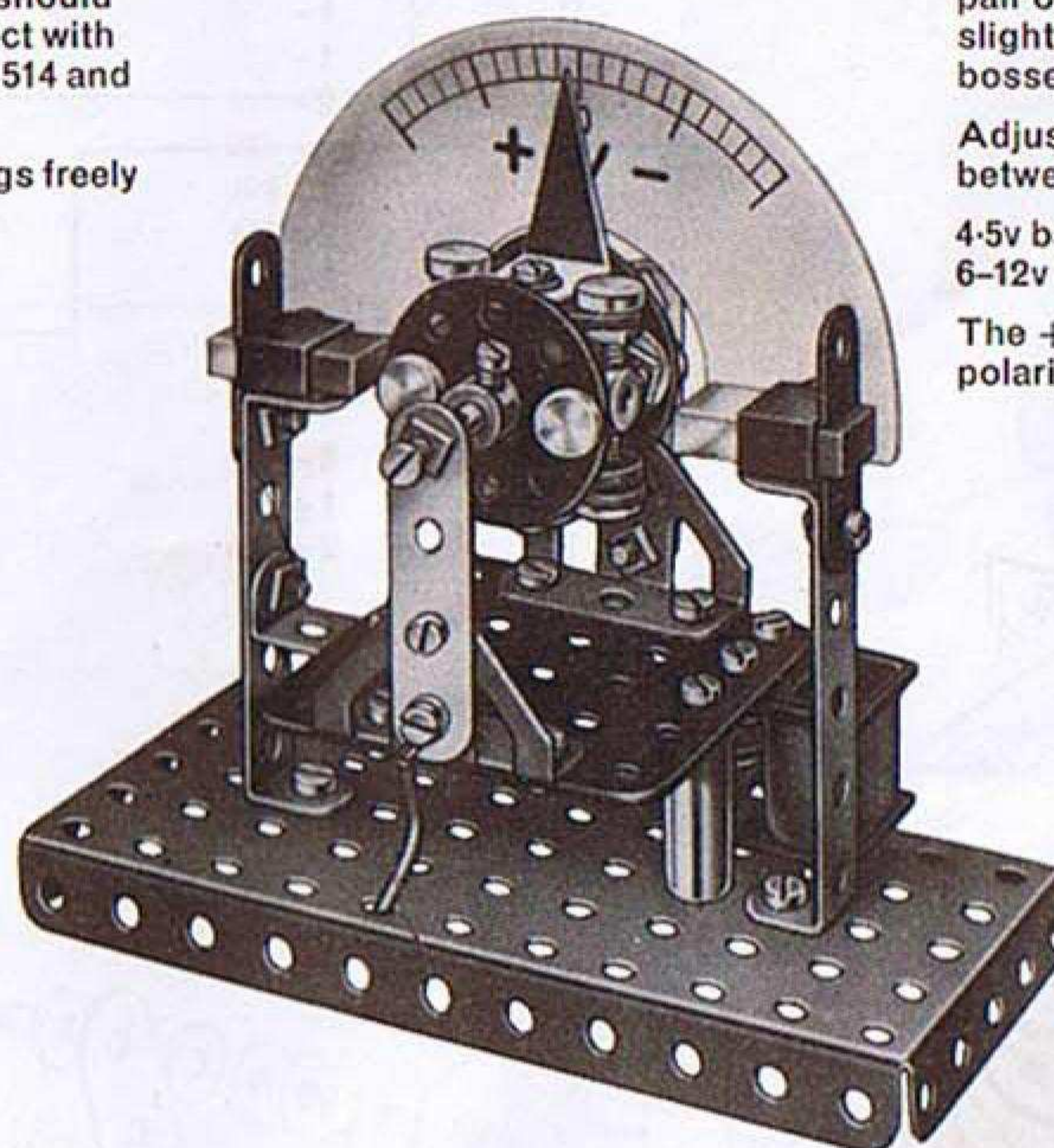

- 2-10
- 1-23
- 28-37a
- 19-37b
- 1-38
- 2-48a
- 1-52
- 2-111a
- 2-126
- 2-140y
- 1-508
- 1-511
- 1-514
- 1-516
- 1-520
- 1-522
- 2-528
- 2-529
- 2-537
- 2-538
- 2-542
- 2-543
- 8-544
- 2-545
- 2-550
- 1-560g
- 1-560k
- 3-561

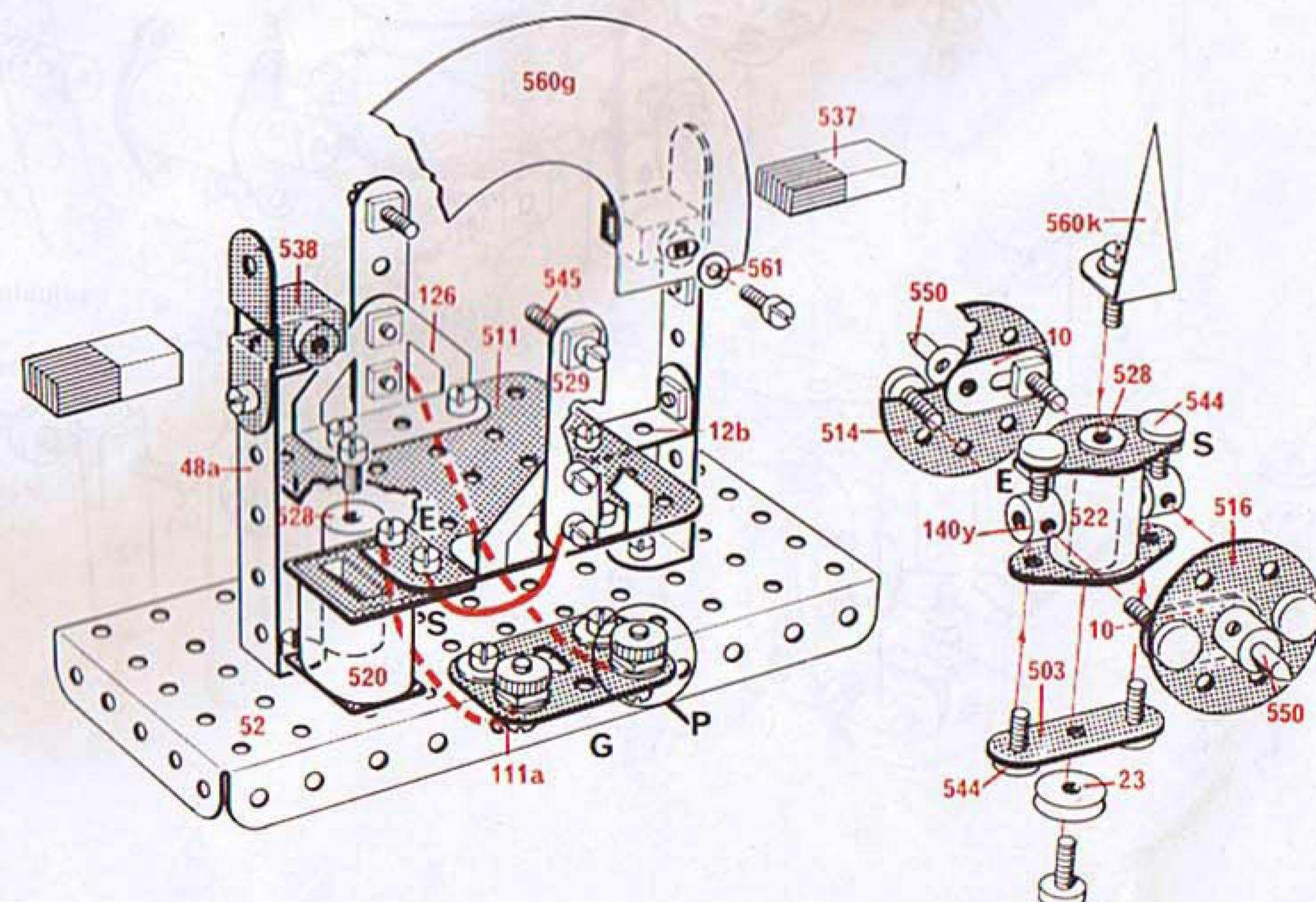

E29 DC Ammeter

This type of meter has two uses :

(1) As a Galvanometer for measuring very low voltages with a maximum of 1.5v DC. For this purpose it should be connected in parallel with the supply source it is measuring.

(2) As an Ammeter for measuring the rate of flow (amperage) of current. For this use it is connected in series with the circuit through which the current it is required to measure is flowing.

4.5v battery.
6-12v DC only.

Assembly of the coil :

Remove the wire from the two Reels 556 and 557 and attach Angle Brackets to them with nuts and Bolts 111d. Connect the Reels together with Insulating Strips 501 at the top and Strips 2 at the bottom and wind them as shown with Wire 558. Remove Strips 2 and attach the bottom Angle Brackets to the baseplate 52.

The + and - signs on the Dial indicate the polarity of the terminal marked P.

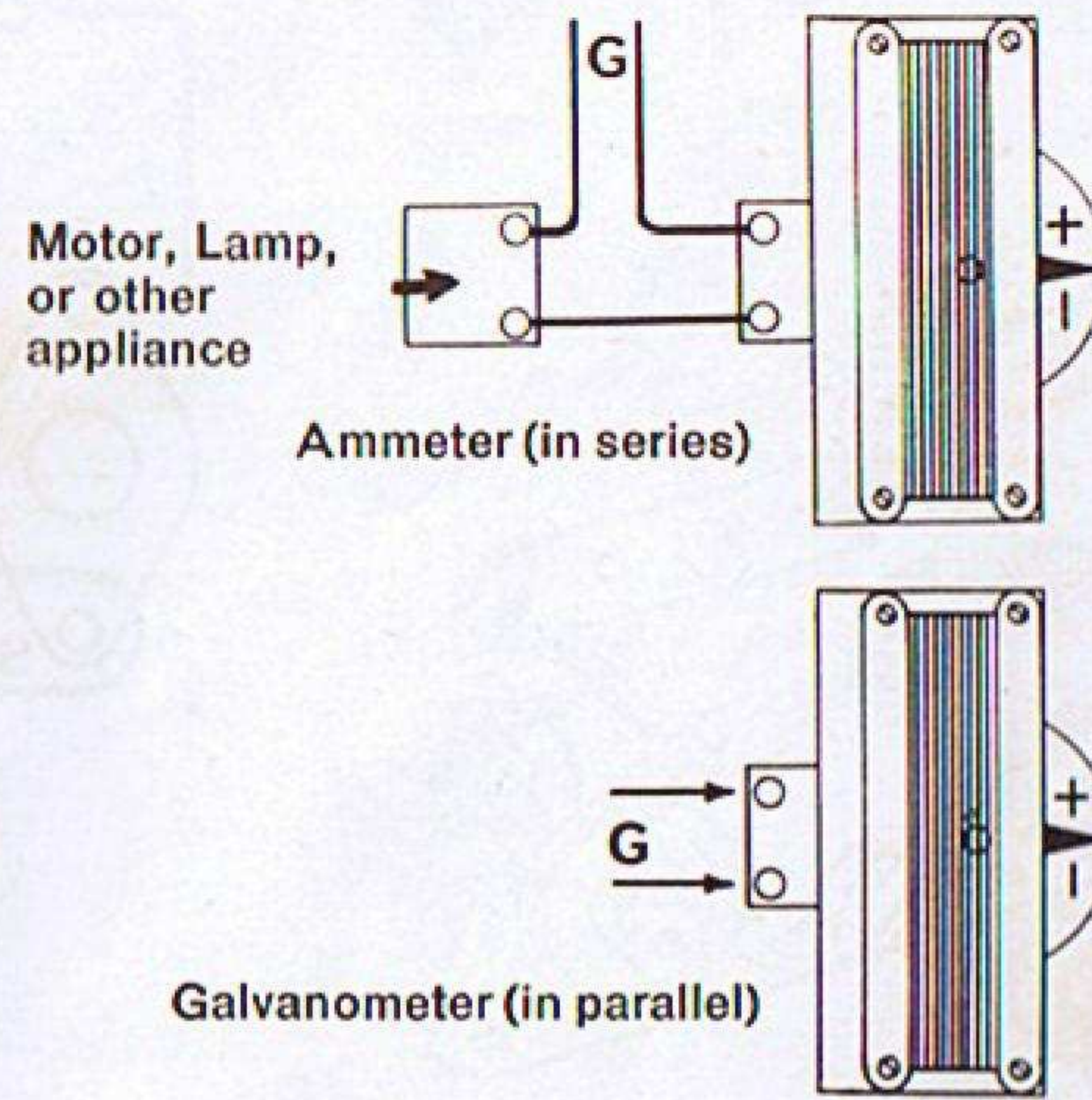

E30 Polarity Indicator

A useful piece of apparatus, which, when connected to a DC current shows which side of the supply is positive and which negative. The + and - signs appear accordingly in the two small windows beside the terminals.

4.5v battery.
6-12v DC only.

- 1 - 2
- 1 - 24
- 1 - 24a
- 34 - 37a
- 15 - 37b
- 10 - 38
- 2 - 48a
- 1 - 52
- 6 - 111a
- 1 - 111c
- 2 - 111d
- 1 - 501
- 2 - 502
- 1 - 507
- 1 - 508
- 2 - 513
- 1 - 514
- 2 - 520
- 4 - 525
- 2 - 526
- 2 - 537
- 2 - 542
- 2 - 545
- 1 - 549
- 1 - 560p
- 4 - 561

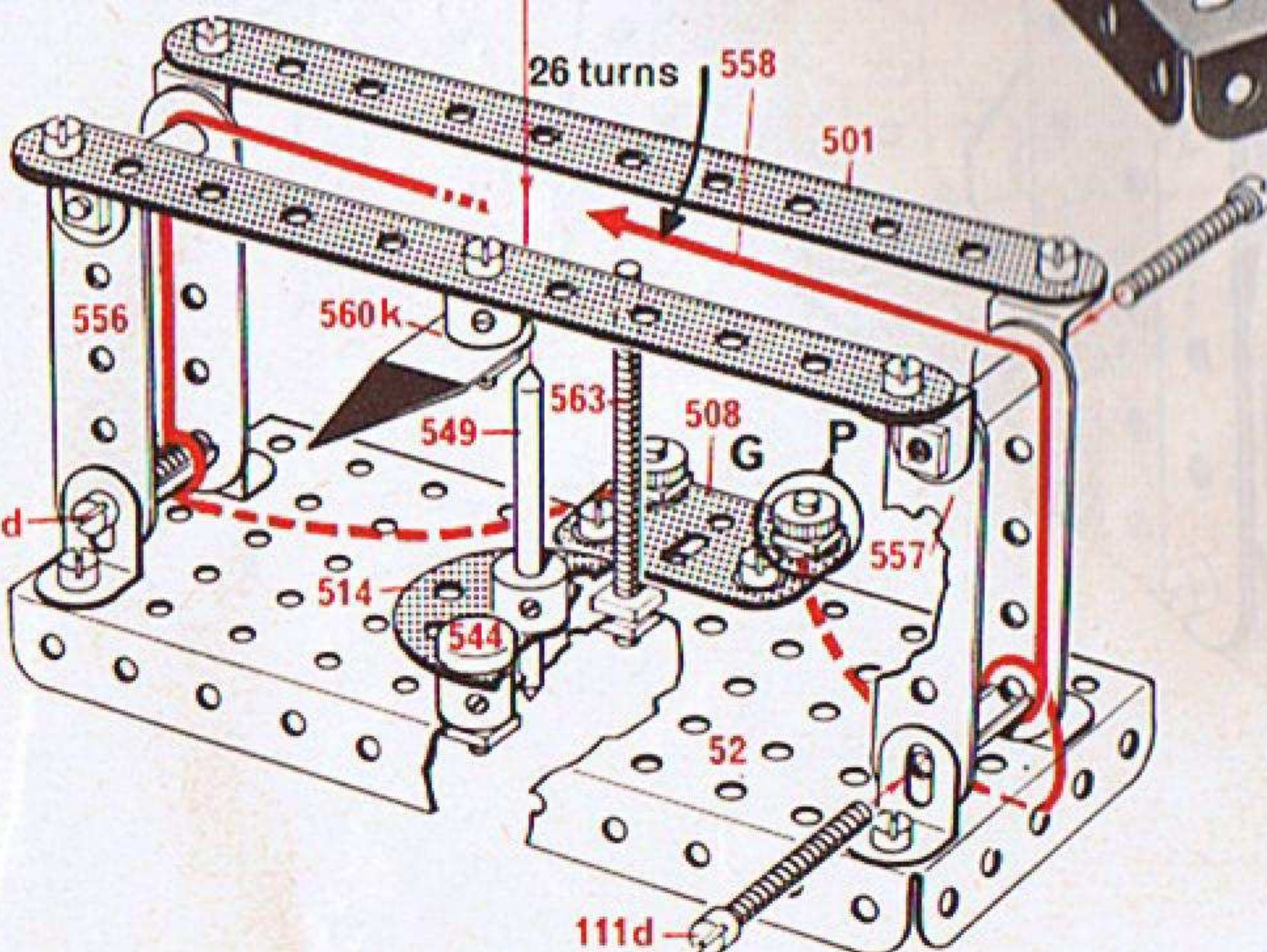
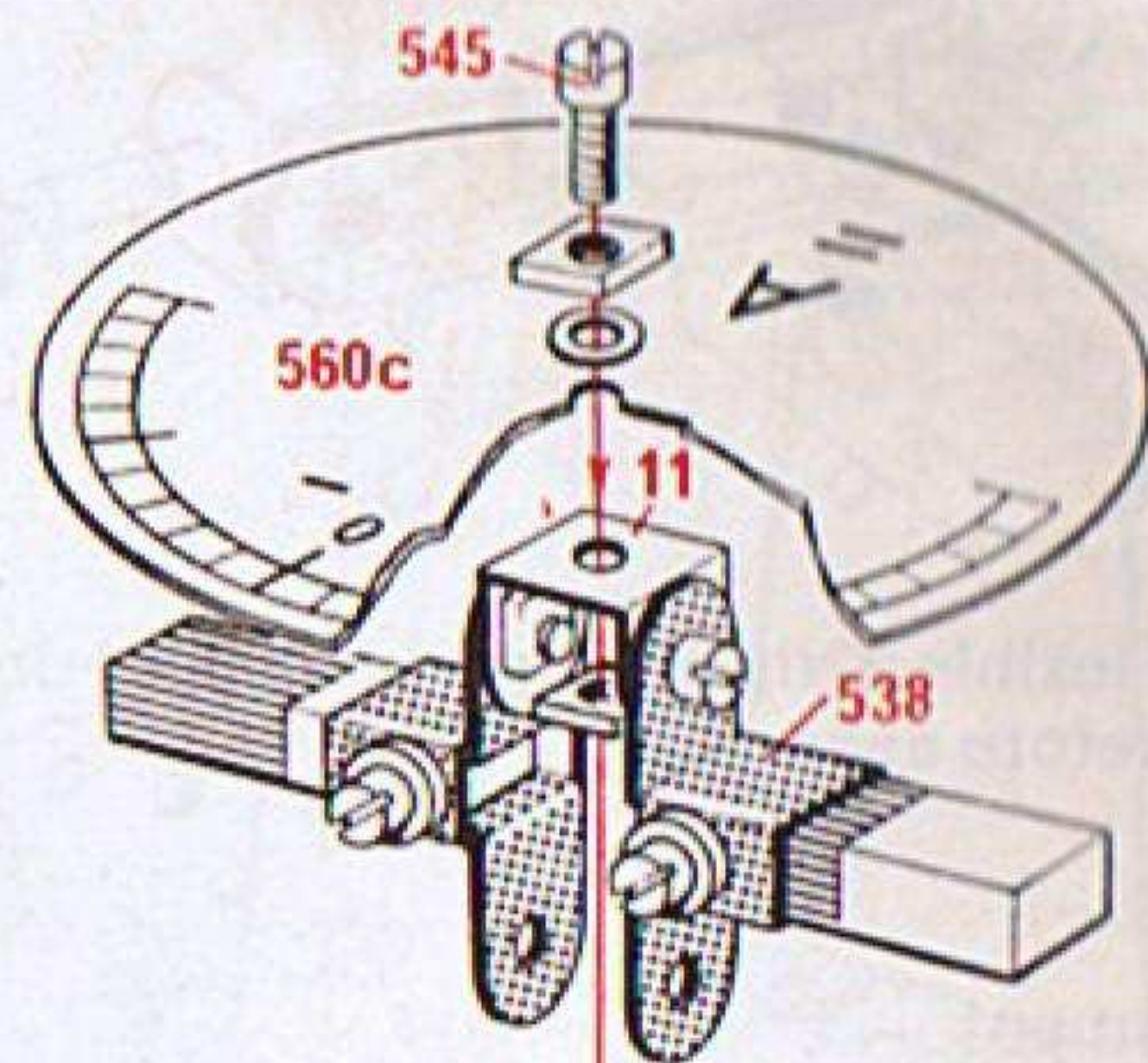
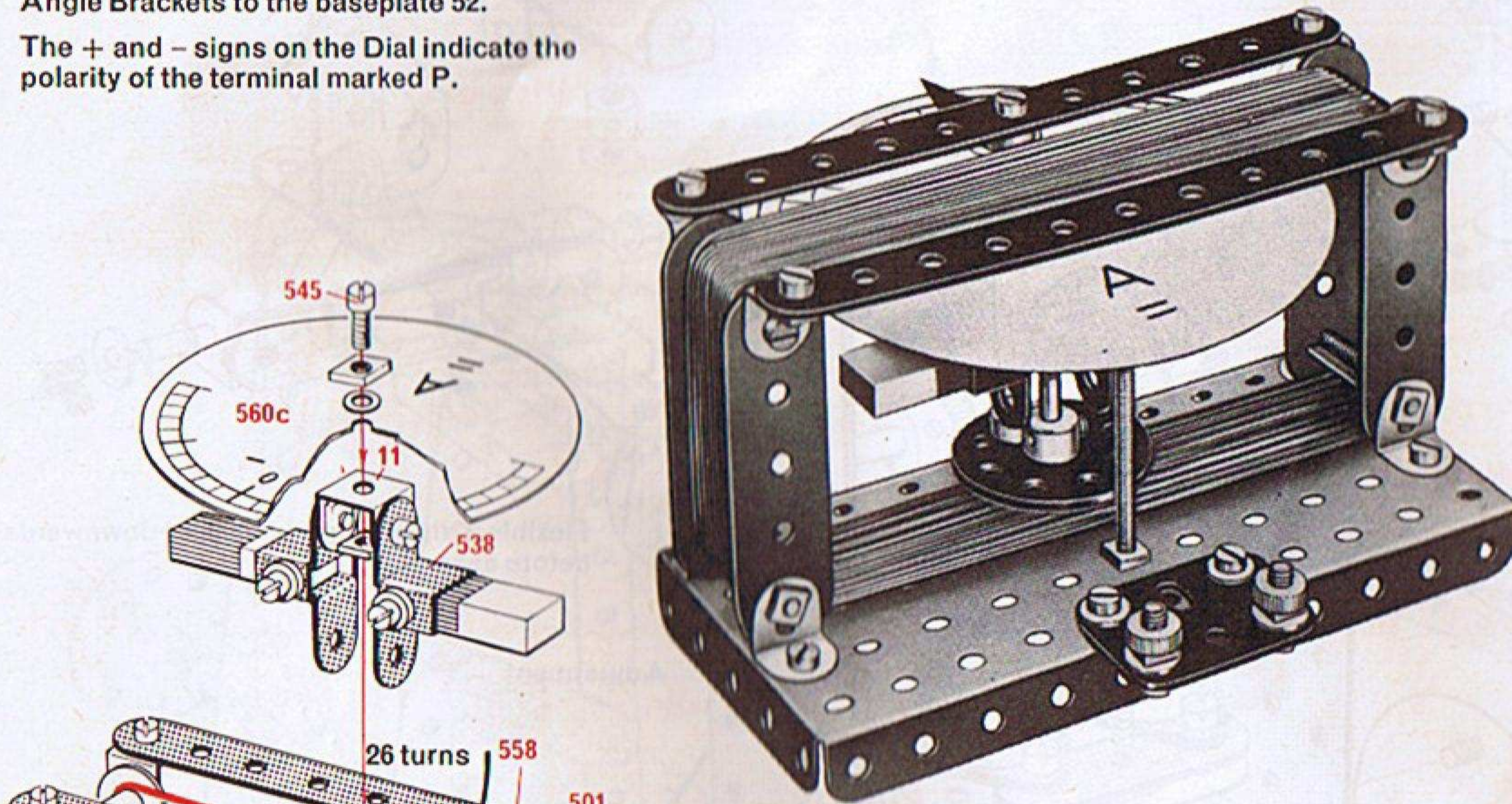
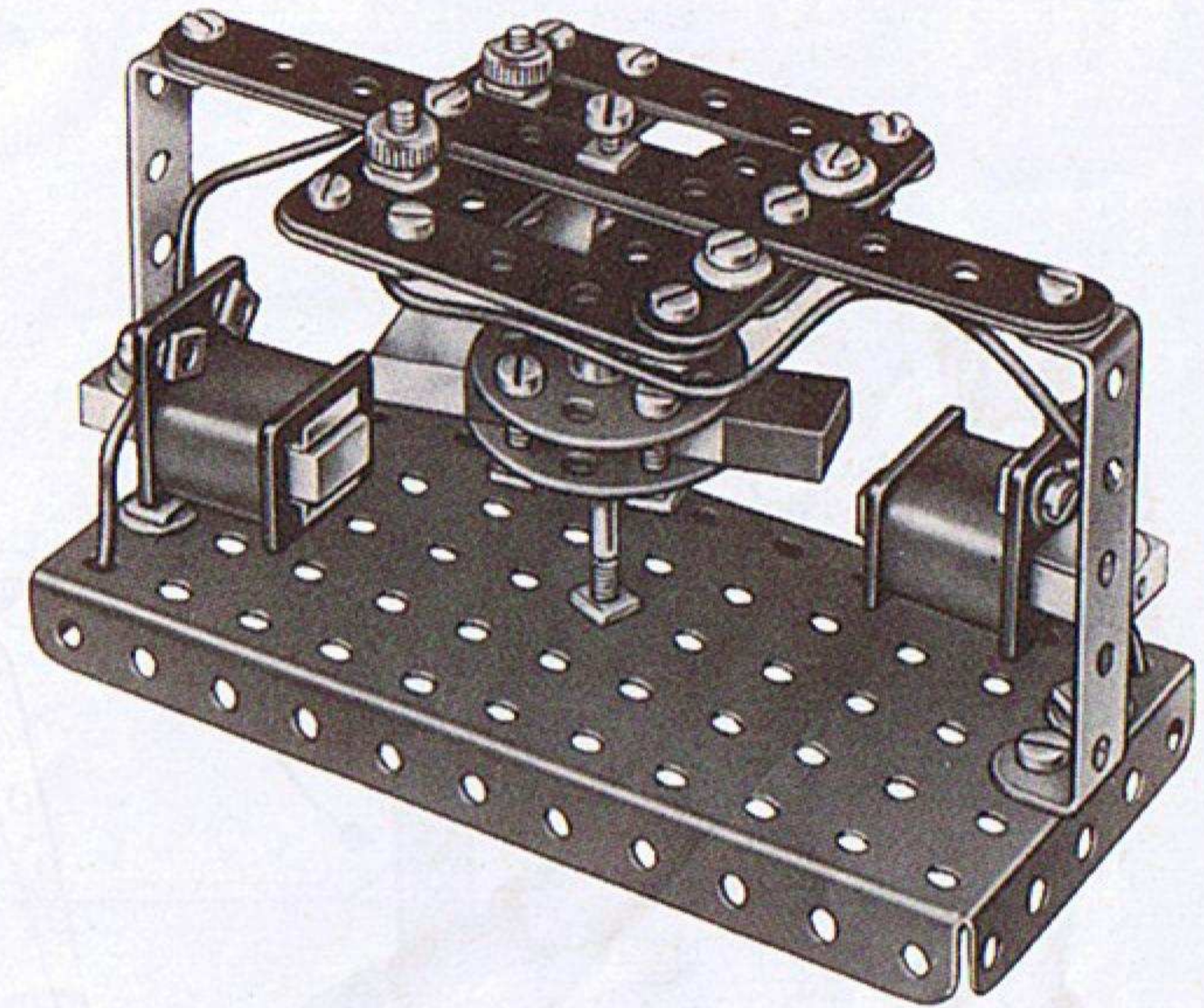

- 1 - 11
- 8 - 12
- 22 - 37a
- 13 - 37b
- 4 - 38
- 1 - 52
- 1 - 59
- 4 - 111
- 2 - 111a
- 4 - 111d
- 1 - 140y
- 2 - 501
- 1 - 508
- 1 - 514
- 2 - 537
- 2 - 538
- 2 - 542
- 1 - 544
- 1 - 545
- 1 - 549
- 1 - 556
- 1 - 557
- 1 - 560c
- 2 - 561
- 1 - 563

The axle must run freely between the Pivot Bolts 545.

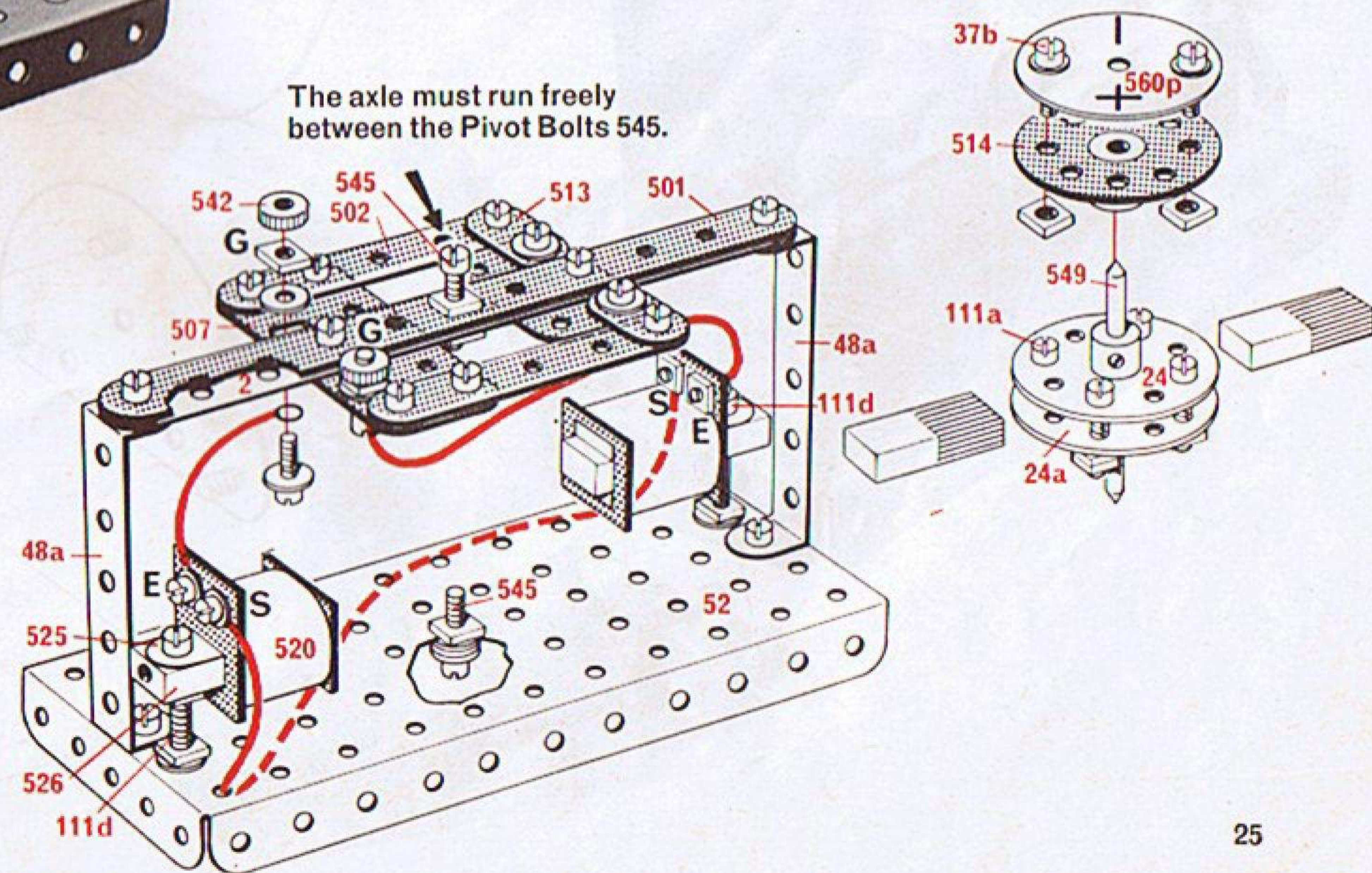

E31 Impulse Counter

This device works on a similar principle to those used for scoring electric pin-tables. Each electrical impulse received at the terminals moves the pointer up one division on the dial.

12v DC only. The model does not work efficiently below this voltage.

It could be used effectively with Switch E2 as a means of impulsing by hand.

- | | | |
|----------|----------|----------|
| 2 - 2 | 3 - 111 | 1 - 518 |
| 9 - 5 | 2 - 111a | 2 - 522 |
| 2 - 10 | 3 - 111c | 2 - 526 |
| 2 - 11 | 2 - 126 | 2 - 528 |
| 2 - 12 | 1 - 126a | 1 - 529 |
| 2 - 12b | 1 - 214 | 1 - 530 |
| 2 - 16 | 2 - 503 | 1 - 531 |
| 5 - 35 | 1 - 507 | 1 - 532 |
| 45 - 37a | 1 - 508 | 1 - 534 |
| 33 - 37b | 1 - 510 | 4 - 542 |
| 27 - 38 | 1 - 511 | 8 - 544 |
| 2 - 48a | 2 - 513 | 1 - 560d |
| 1 - 52 | 1 - 514 | 4 - 561 |
| 1 - 59 | 1 - 516 | |

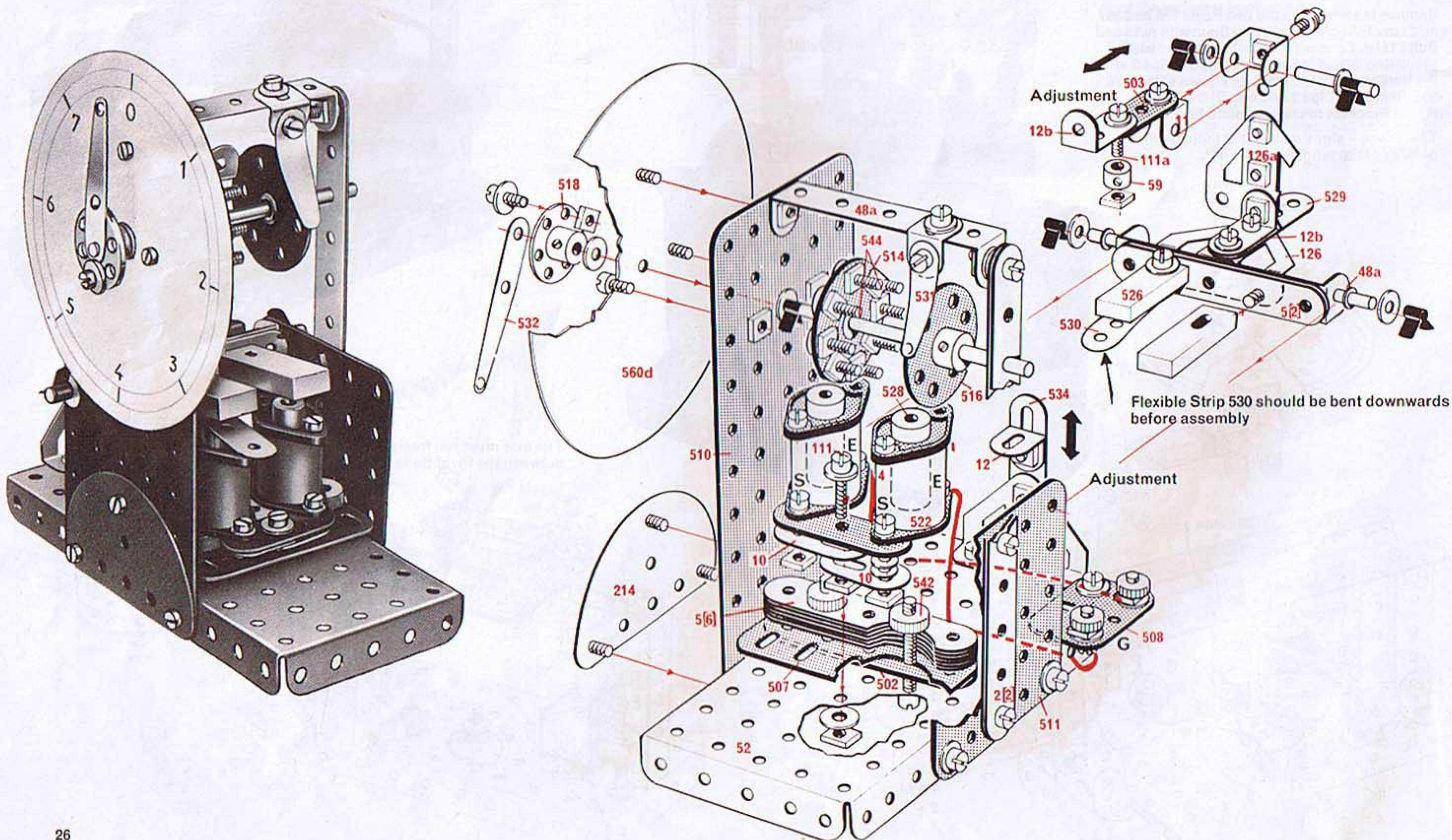
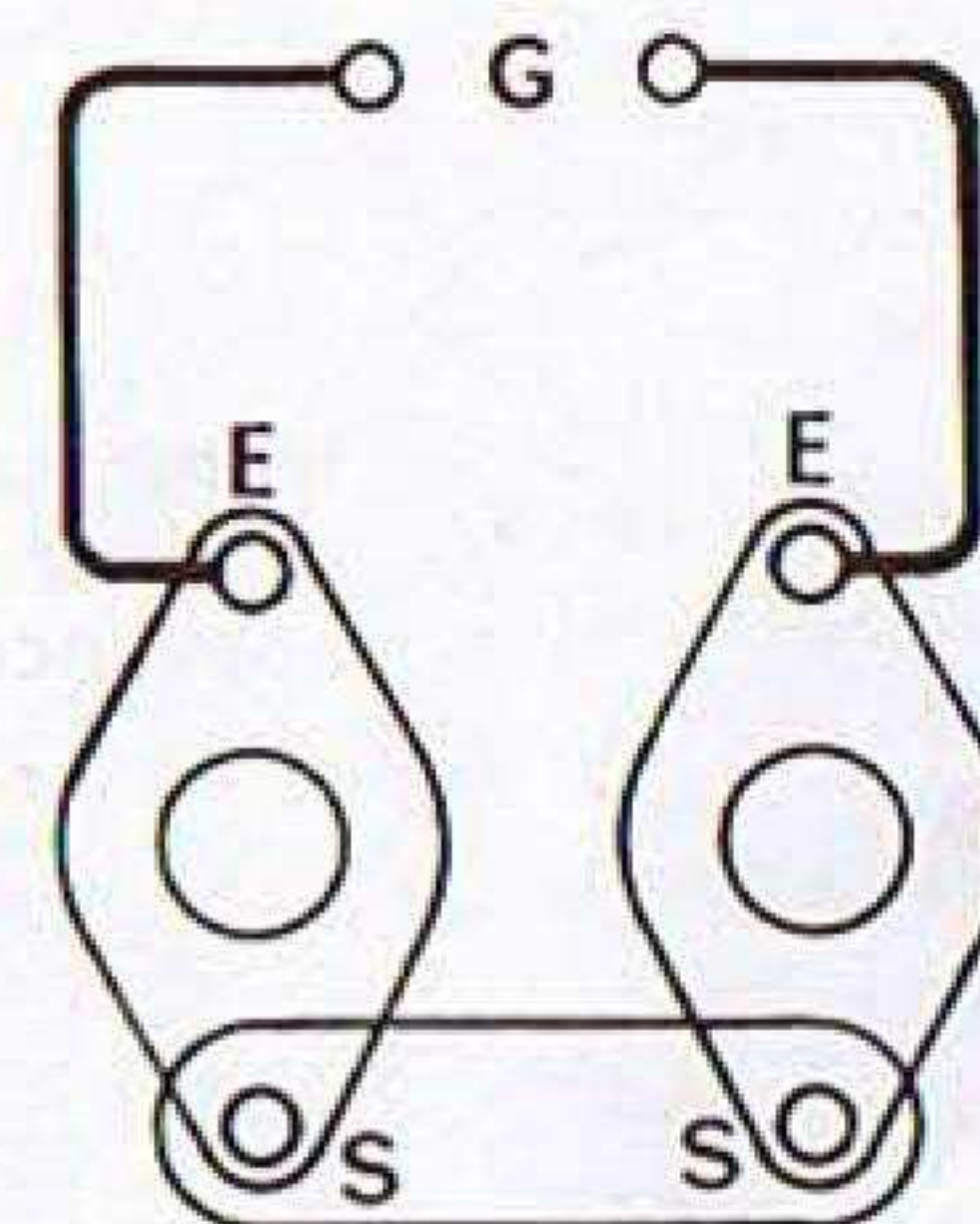

E32 Electric Field Gun

This novel gun has a range of several yards, 'firing' a Driving Band 186b.

It has a handwheel to raise and lower the barrel and it can be fired by remote control (using switch E2 for example).

To load and fire the gun (see diagram):

Push the Threaded Pin 115 backwards and stretch the Driving Band between it and the bolt at the end of the barrel. When an electric current is fed to the terminals the Coils attract the moving arm thus pulling the Angle Bracket 12c downwards and allowing the Threaded Pin 115 to release the Band.

4.5v battery.

6-15v AC or DC.

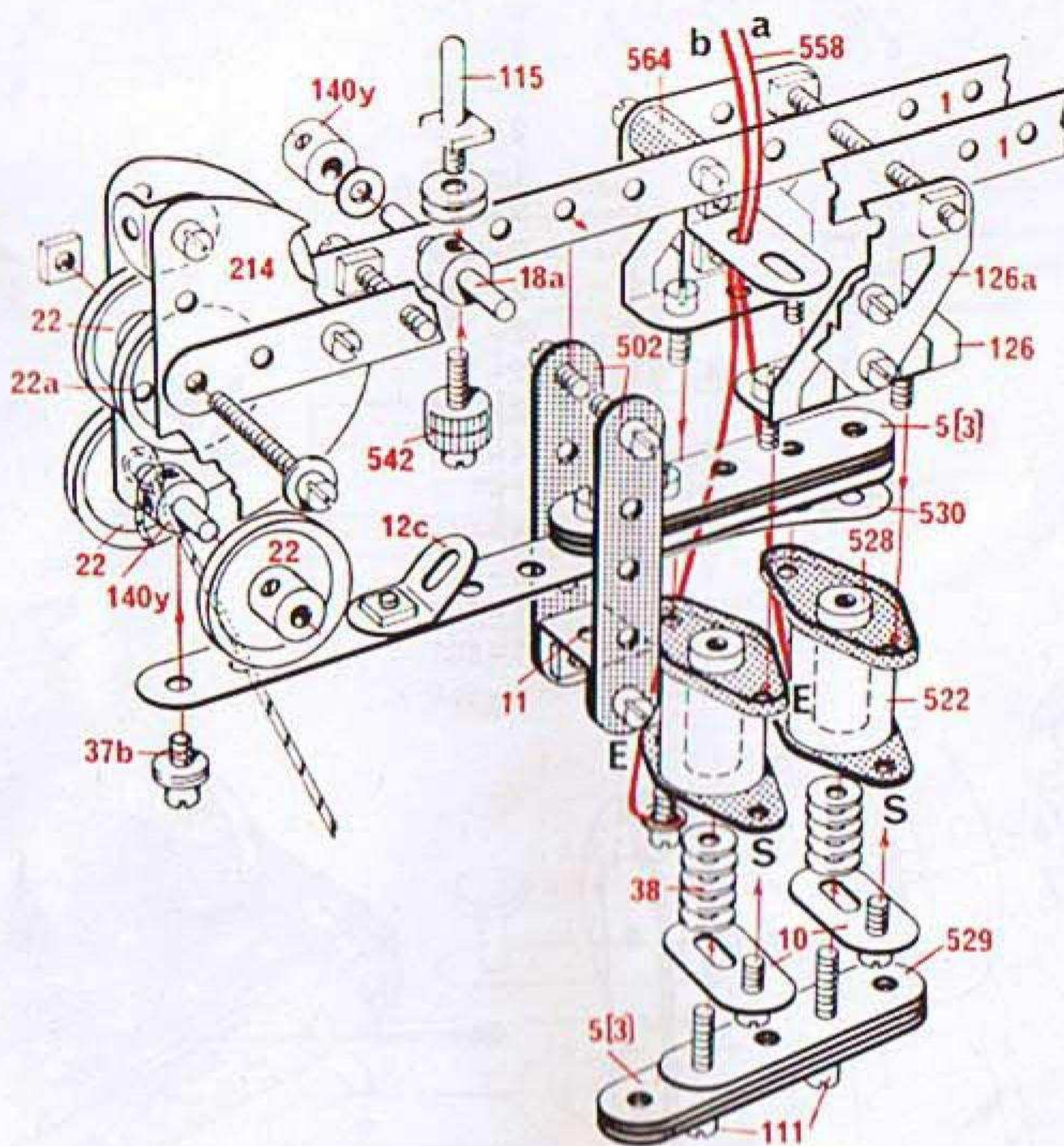

2 - 1	46 - 37b	2 - 214
5 - 2	31 - 38	2 - 502
6 - 5	1 - 48a	2 - 503
2 - 10	1 - 52	1 - 508
2 - 11	1 - 59	1 - 514
1 - 12	2 - 111	1 - 516
1 - 12b	4 - 111a	2 - 522
1 - 12c	1 - 111c	2 - 528
2 - 16	2 - 115	1 - 529
1 - 18a	2 - 126	1 - 530
1 - 18b	2 - 126a	2 - 534
4 - 22	2 - 140y	4 - 542
1 - 22a	1 - 176	2 - 561
1 - 24	1 - 186b	1 - 563
2 - 35	2 - 189	2 - 564
46 - 37a		

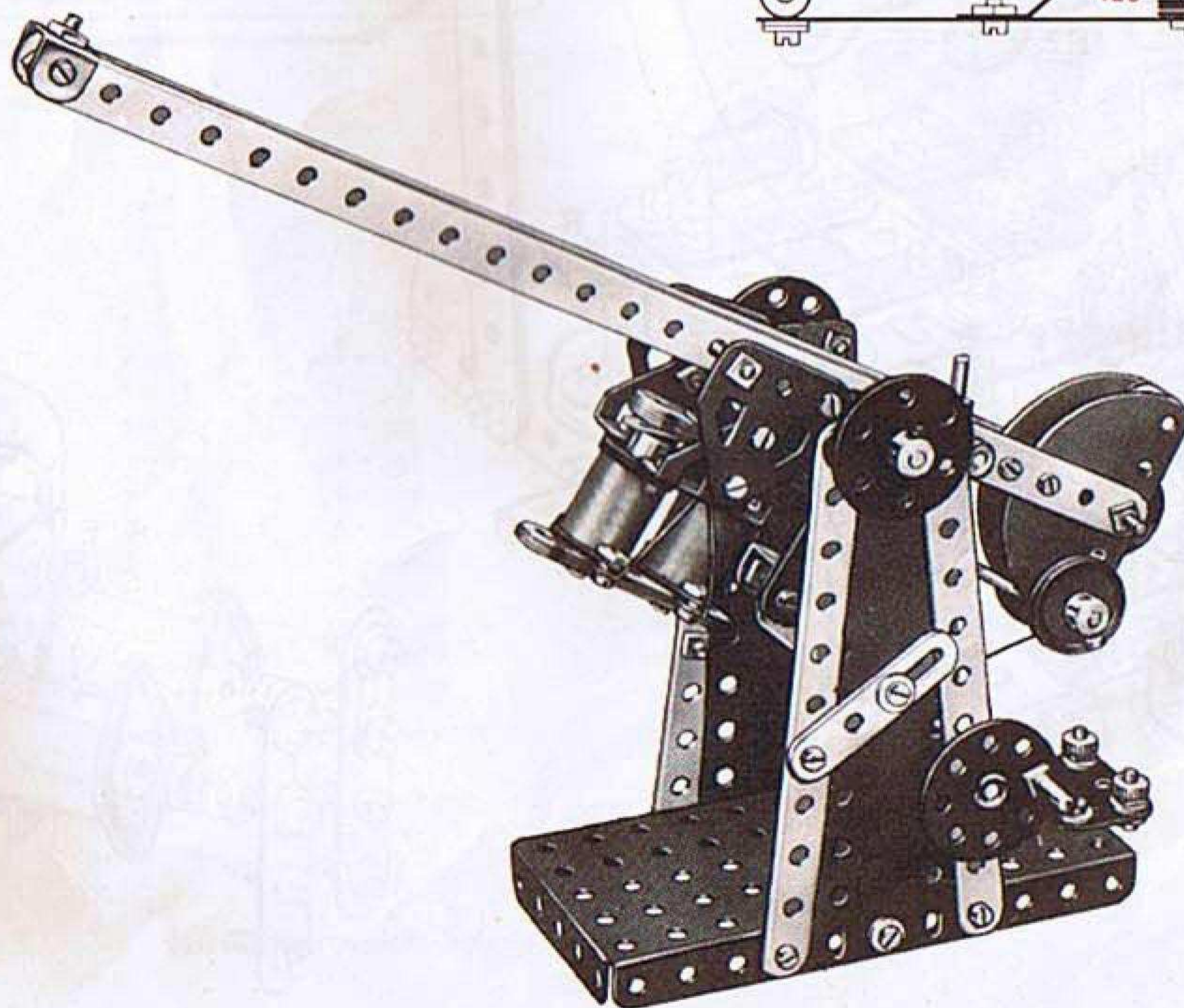
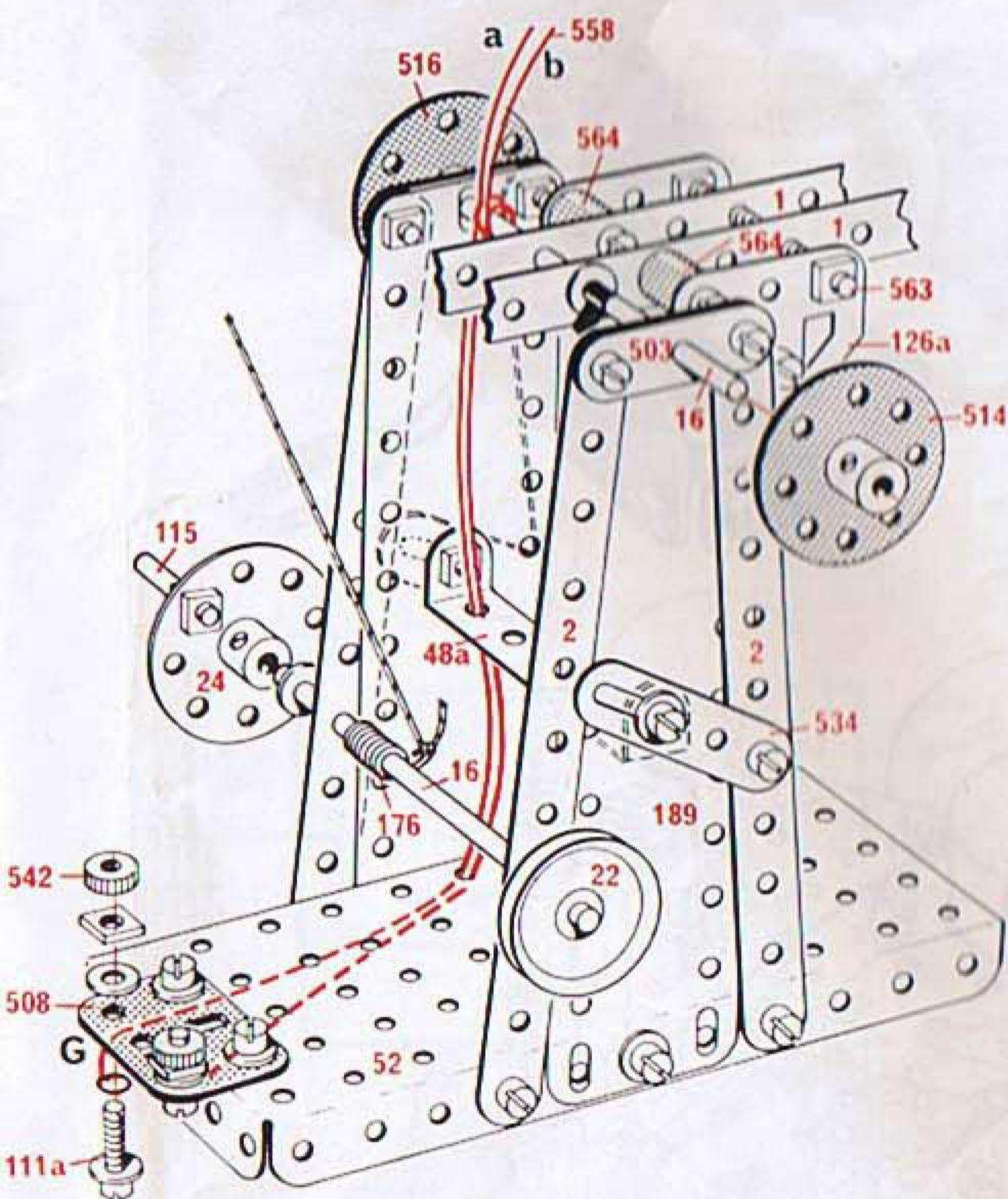

The Obtuse Angle Bracket 12c should be adjusted so as only just to hold the bolt when the gun is cocked

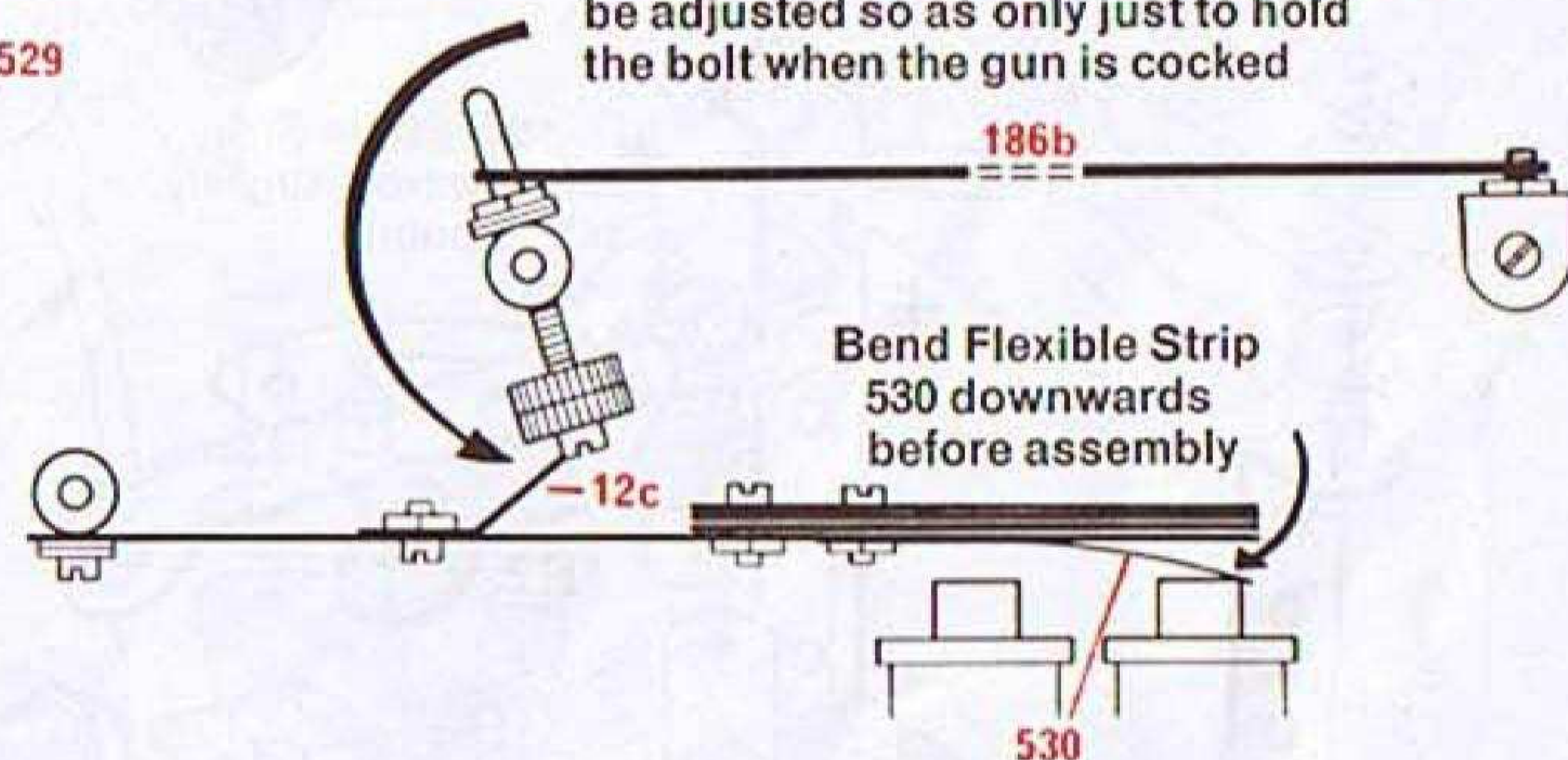

E33 Telegraph Receiver with Bell and Morse Key

This model is simpler to use and more interesting when operated by two people. One person can then call up and transmit a message to the second person who can receive and decode it some distance away.

R. Adjust the height of the paper support at these three points so that the pen touches the paper when the moving arm is drawn downwards by the electro-magnets.

R2. Adjuster for limiting the upward movement of the arm that carries the pen.

Follow the wiring diagrams carefully when wiring up the models.

4.5v battery.

6-15v AC or DC.

4-2	1-59	2-520
6-5	1-111	2-522
1-10	4-111a	4-525
1-11	8-111c	2-526
11-12	1-111d	1-527
2-12b	2-126	2-528
2-12c	2-126a	2-529
1-17	1-155	2-530
1-18b	1-188	2-531
1-19g	1-213	2-532
1-22	1-214	2-534
1-24	1-502	4-542
2-35	2-503	1-543
60-37a	1-508	1-559
56-37b	1-510	10-561
40-38	1-513	1-562
2-48a	1-514	1-563
1-52	1-516	1-564

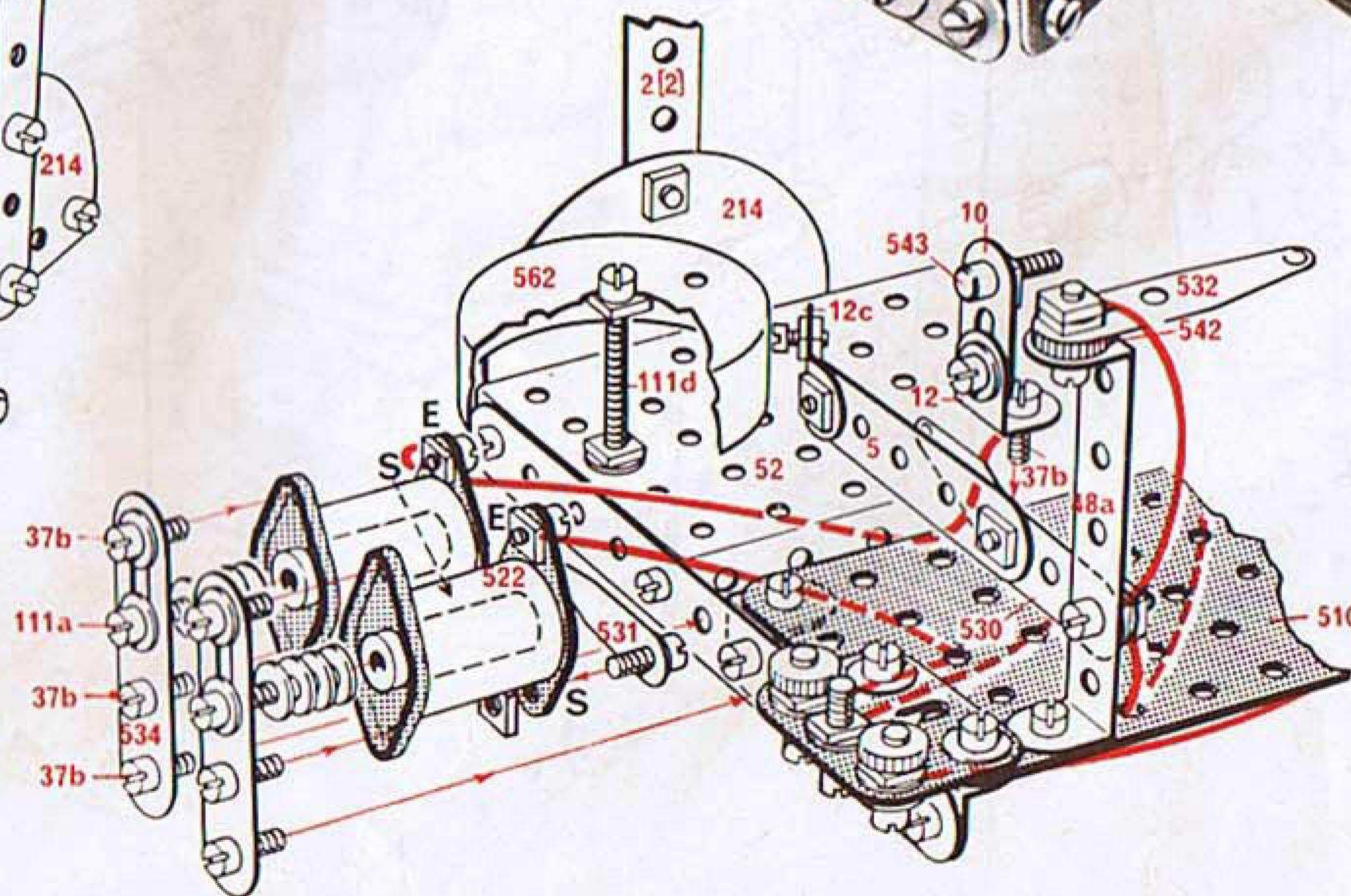
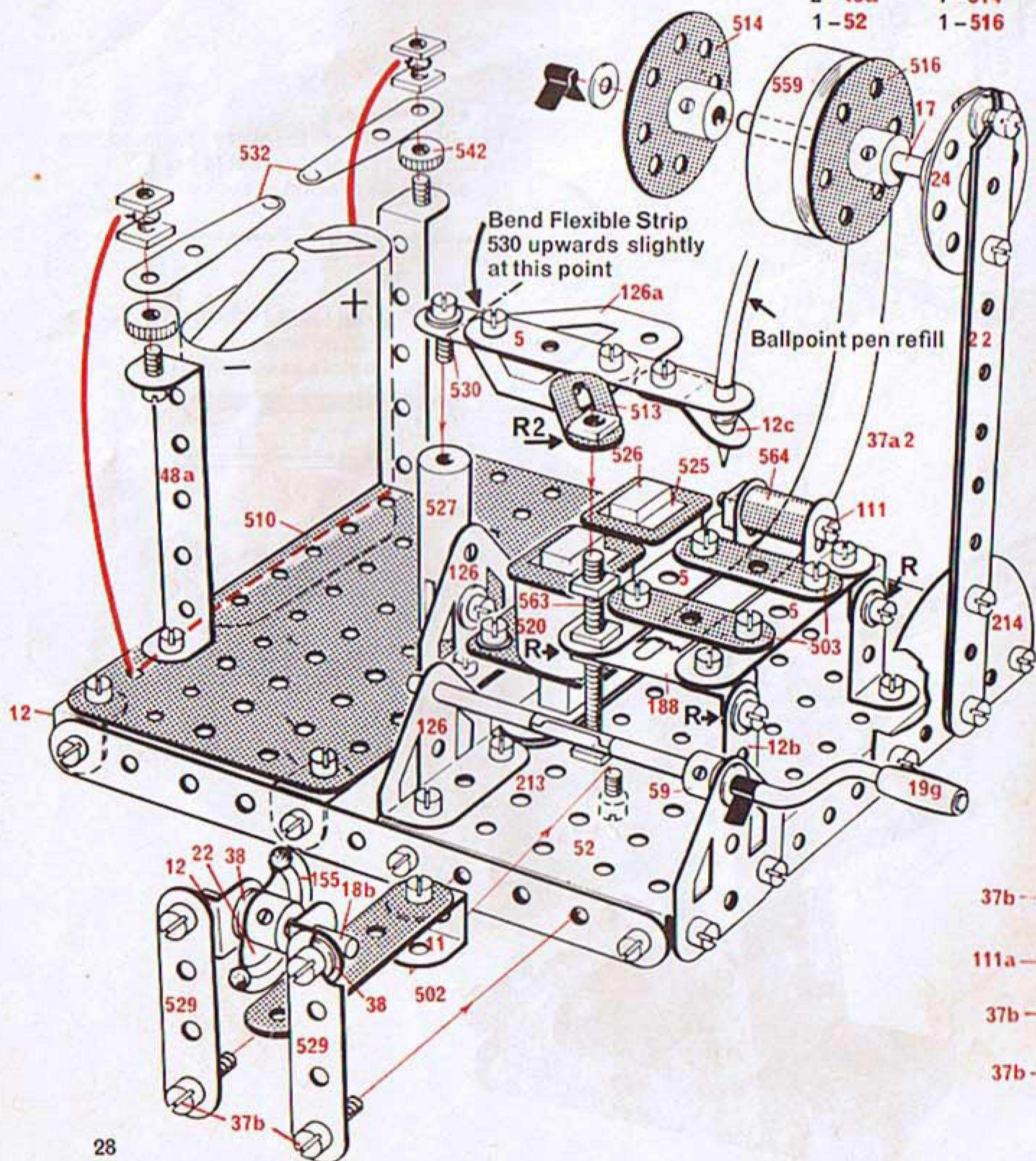
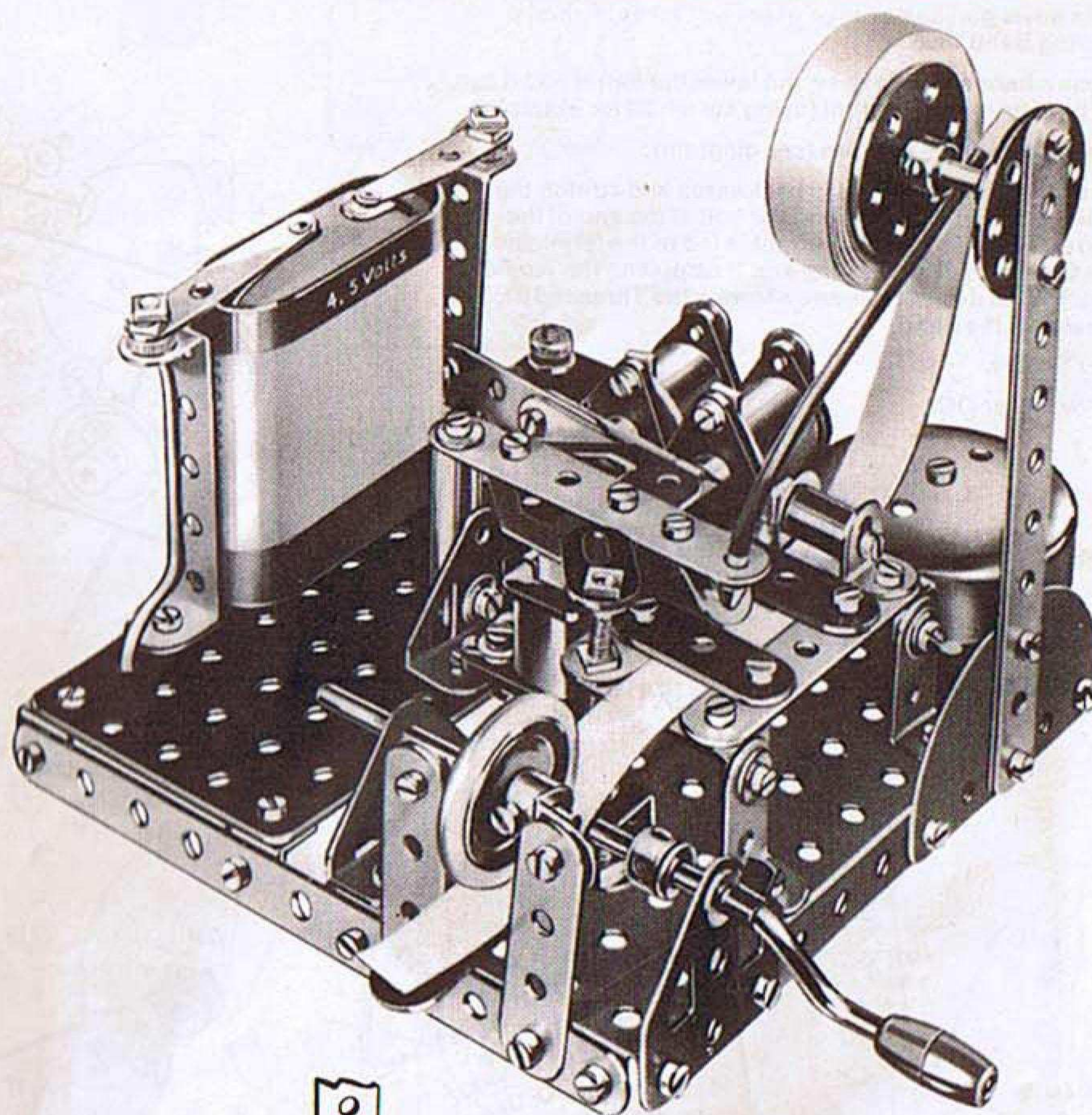

Morse Key

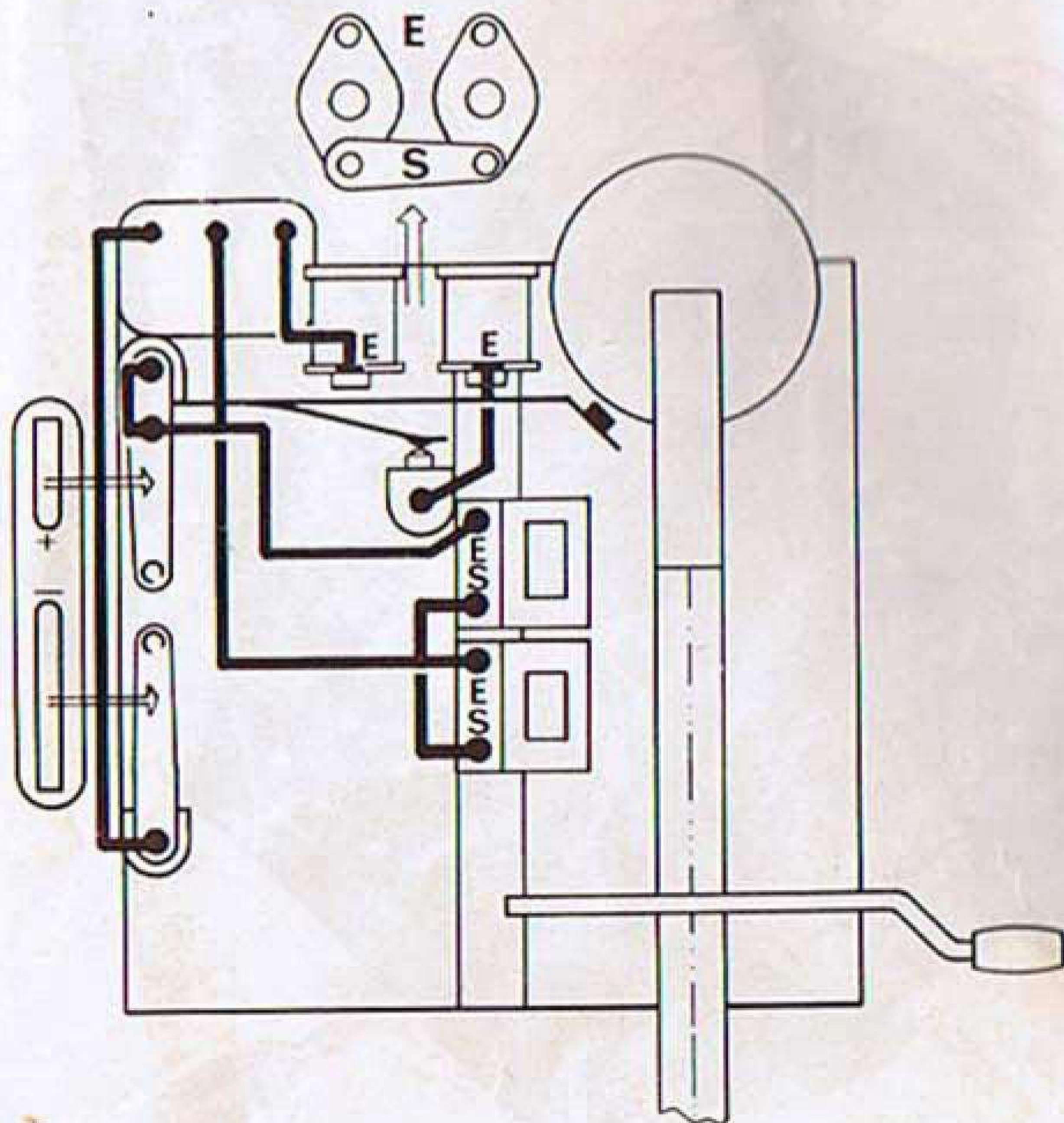
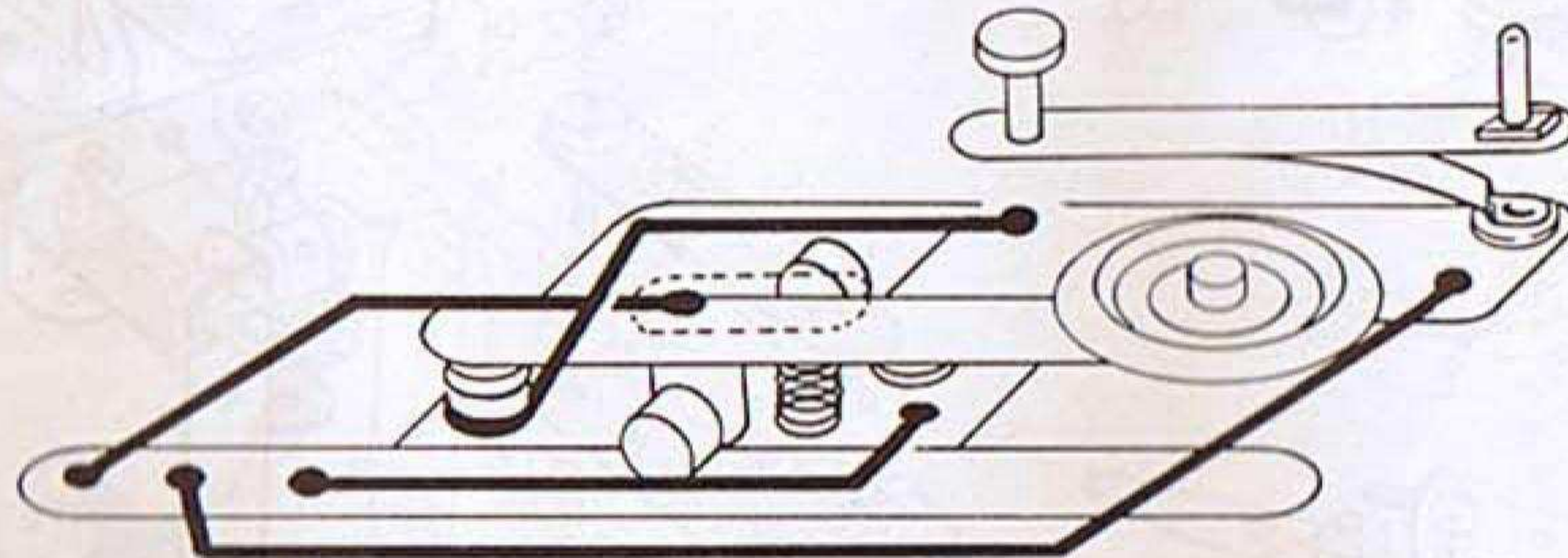
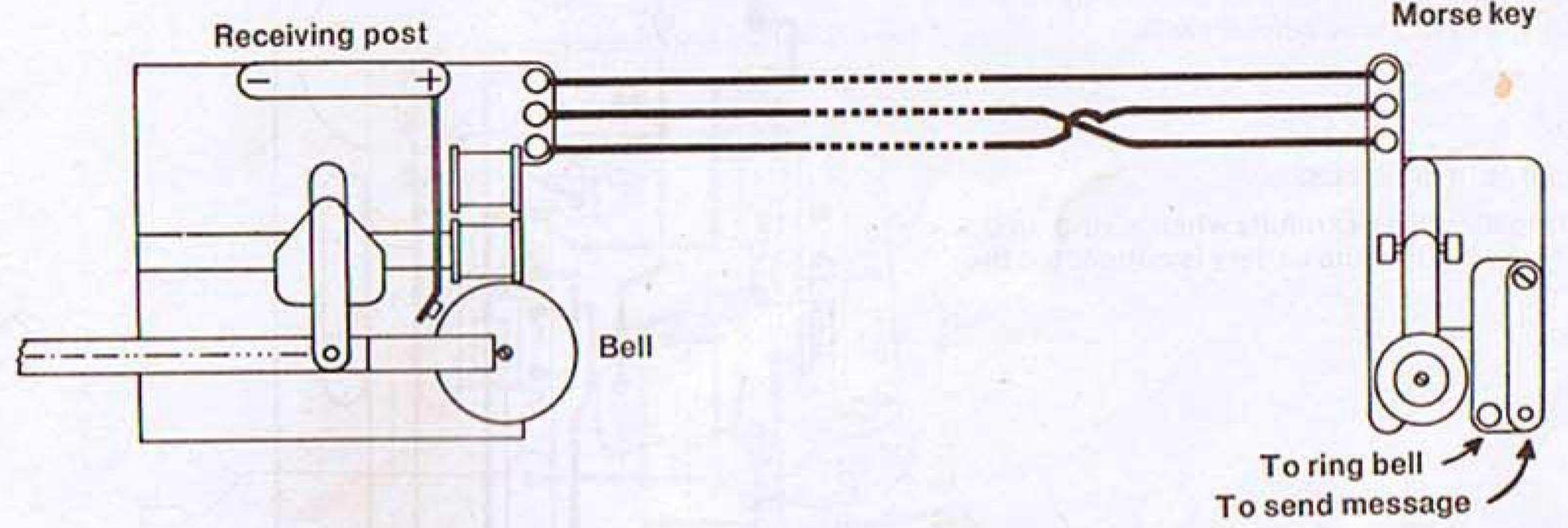
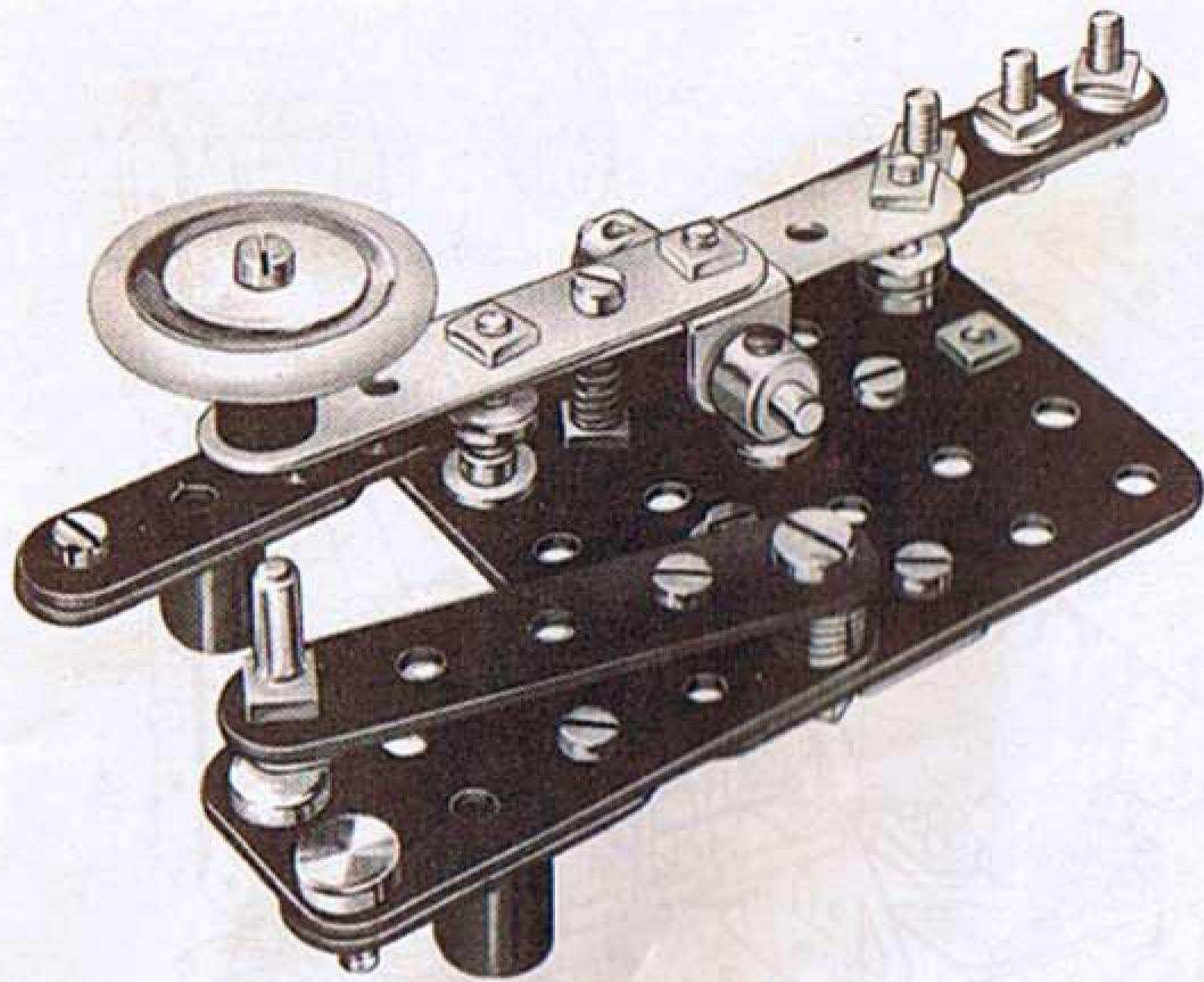

- | | |
|----------|----------|
| 2 - 5 | 1 - 147b |
| 2 - 10 | 1 - 155 |
| 1 - 11 | 1 - 501 |
| 1 - 18a | 1 - 502 |
| 1 - 22a | 1 - 507 |
| 29 - 37a | 1 - 511 |
| 16 - 37b | 1 - 533 |
| 16 - 38 | 2 - 539 |
| 1 - 38d | 1 - 543 |
| 3 - 111a | 5 - 544 |
| 3 - 111c | 1 - 545 |
| 1 - 115 | 4 - 561 |
| 1 - 120b | 1 - 564 |
| 2 - 140y | |

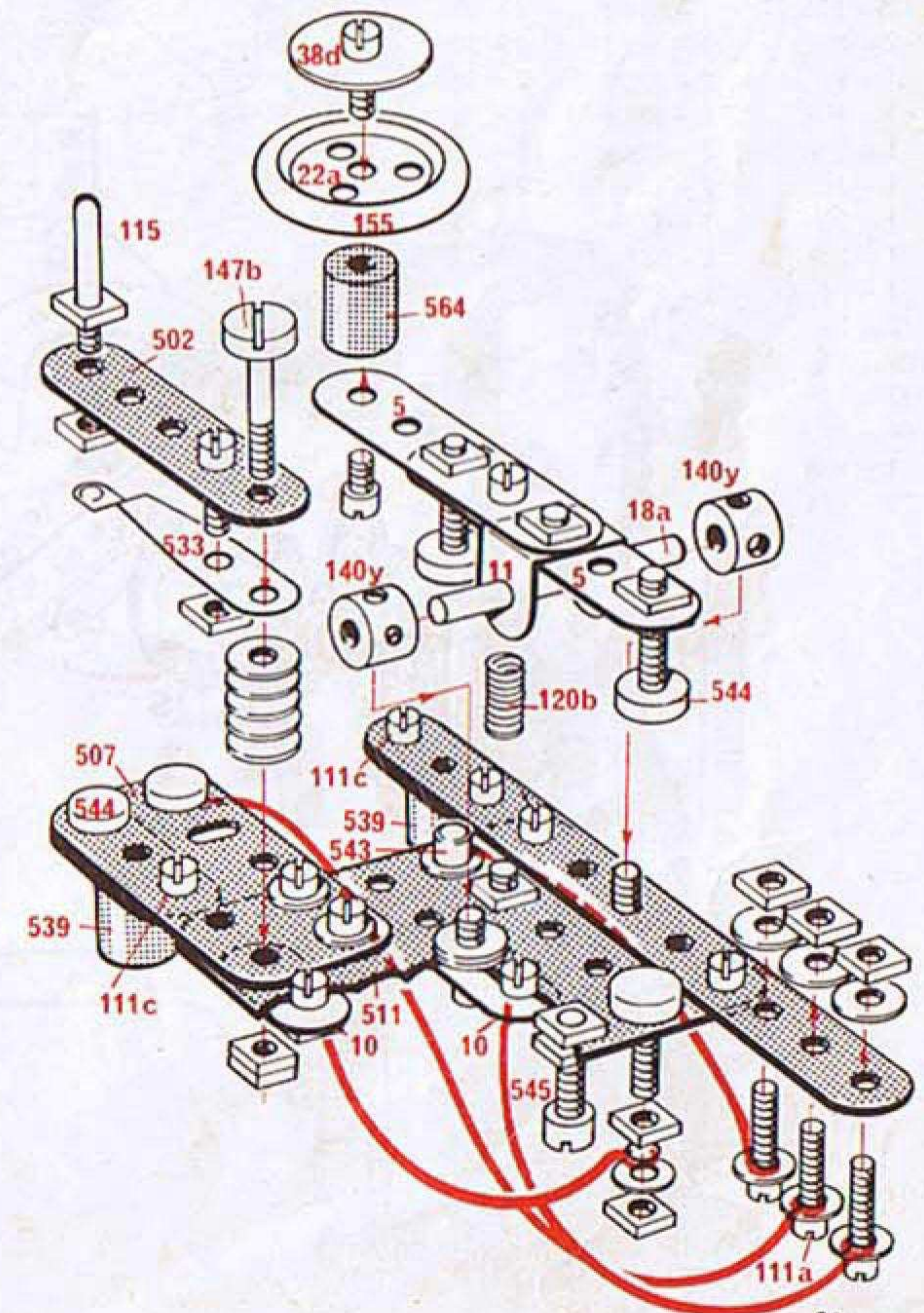

For the Morse alphabet see E8 (Buzzer)

E34 Complete Morse Telegraph

In order to build this complete two-way telegraph system extra parts are required as detailed on page 2 of cover. Only two wires are required to connect the two telegraph posts and one of these can be connected through the domestic water pipes or some similar earth.

4-5v battery.

6-15v AC or DC.

R and R2. Same as in model E33.

Follow the wiring diagrams carefully when wiring up the models and make sure that the battery is connected the right way round.

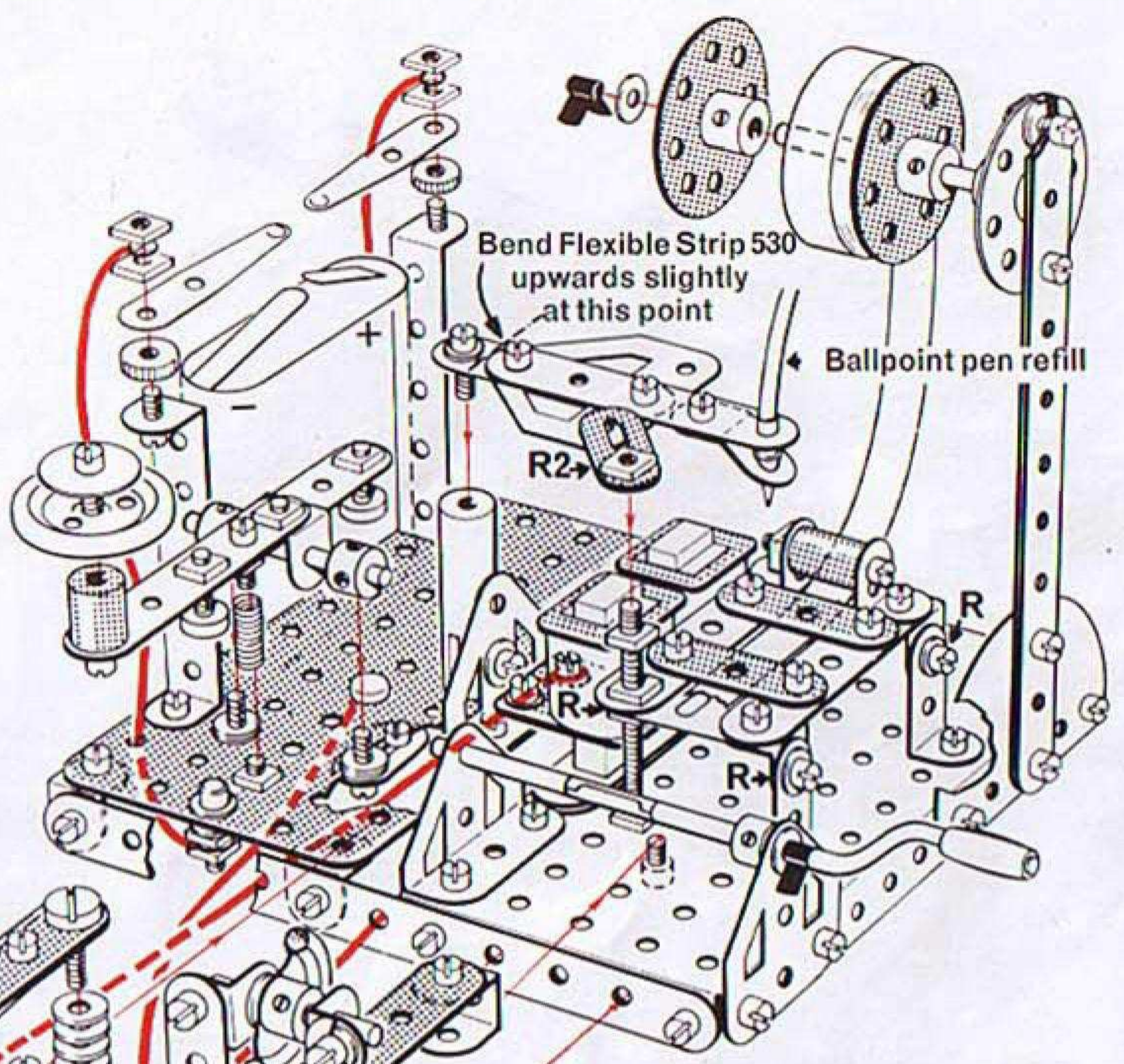
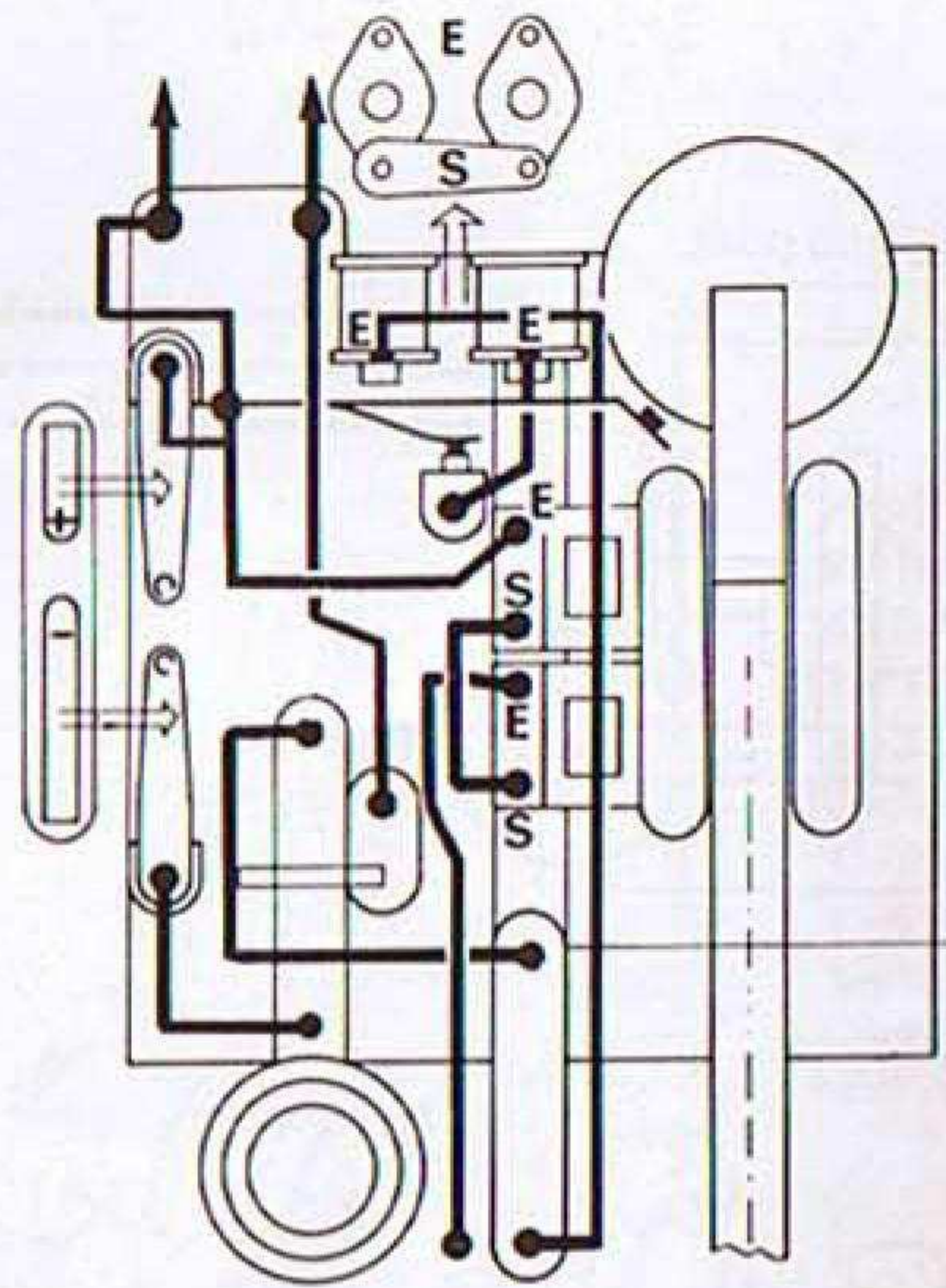

- | | | | |
|-----------|----------|---------|----------|
| 3 - 2 | 1 - 52 | 1 - 510 | 2 - 531 |
| 8 - 5 | 1 - 59 | 1 - 513 | 2 - 532 |
| 2 - 10 | 1 - 111 | 1 - 514 | 1 - 533 |
| 2 - 11 | 3 - 111a | 1 - 516 | 2 - 534 |
| 11 - 12 | 9 - 111c | 2 - 520 | 4 - 542 |
| 2 - 12b | 1 - 111d | 2 - 522 | 2 - 543 |
| 2 - 12c | 1 - 115 | 4 - 525 | 5 - 544 |
| 1 - 17 | 1 - 120b | 2 - 526 | 1 - 559 |
| 1 - 18a | 2 - 126 | 1 - 527 | 10 - 561 |
| 1 - 18b | 2 - 126a | 2 - 528 | 1 - 562 |
| 1 - 19g | 2 - 140y | 2 - 529 | 1 - 563 |
| 1 - 22 | 1 - 147b | 2 - 530 | 2 - 564 |
| 1 - 22a | 2 - 155 | | |
| 1 - 24 | 1 - 188 | | |
| 2 - 35 | 1 - 213 | | |
| 102 - 37a | 1 - 214 | | |
| 77 - 37b | 2 - 502 | | |
| 44 - 38 | 2 - 503 | | |
| 1 - 38d | 1 - 507 | | |
| 2 - 48a | 1 - 508 | | |

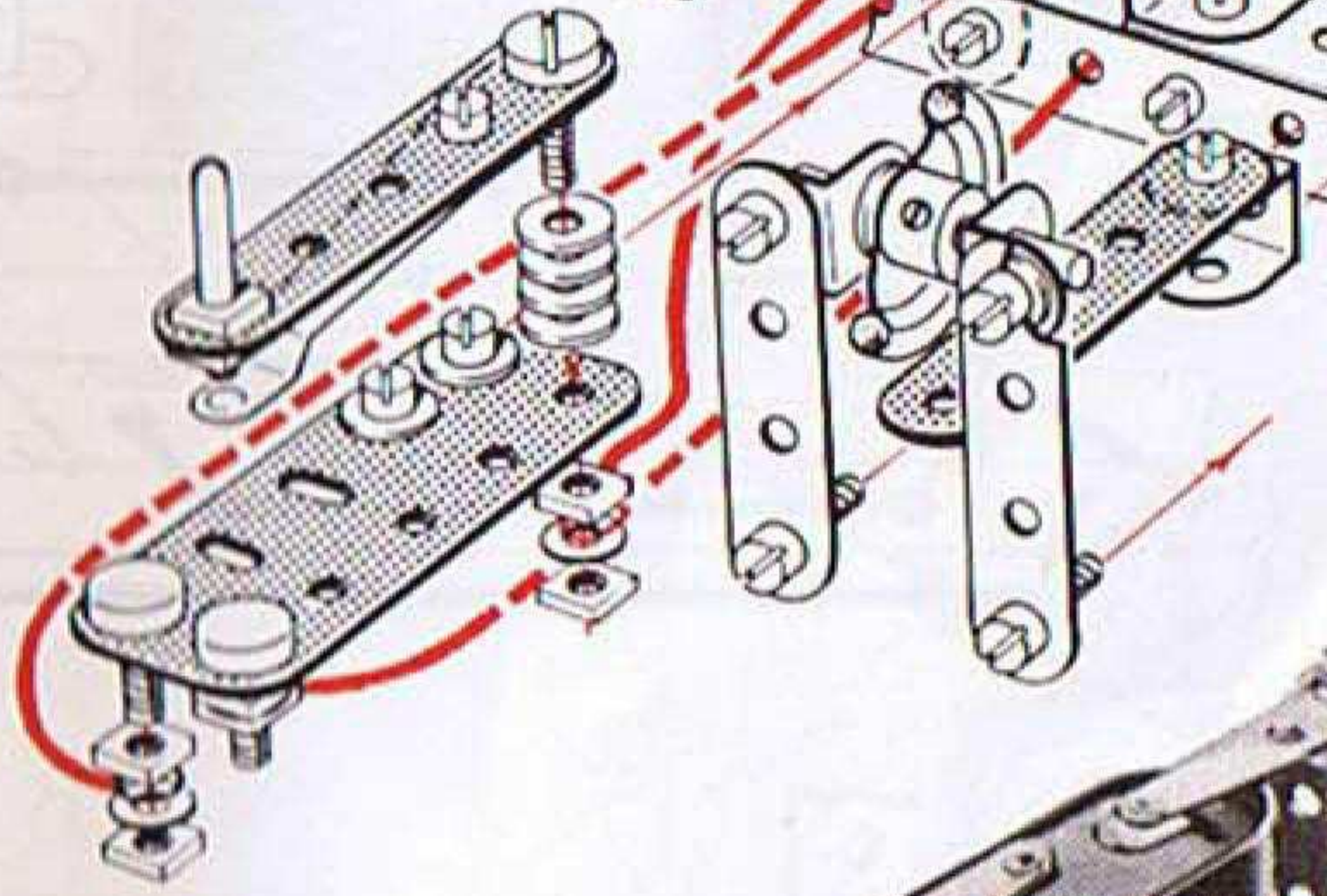
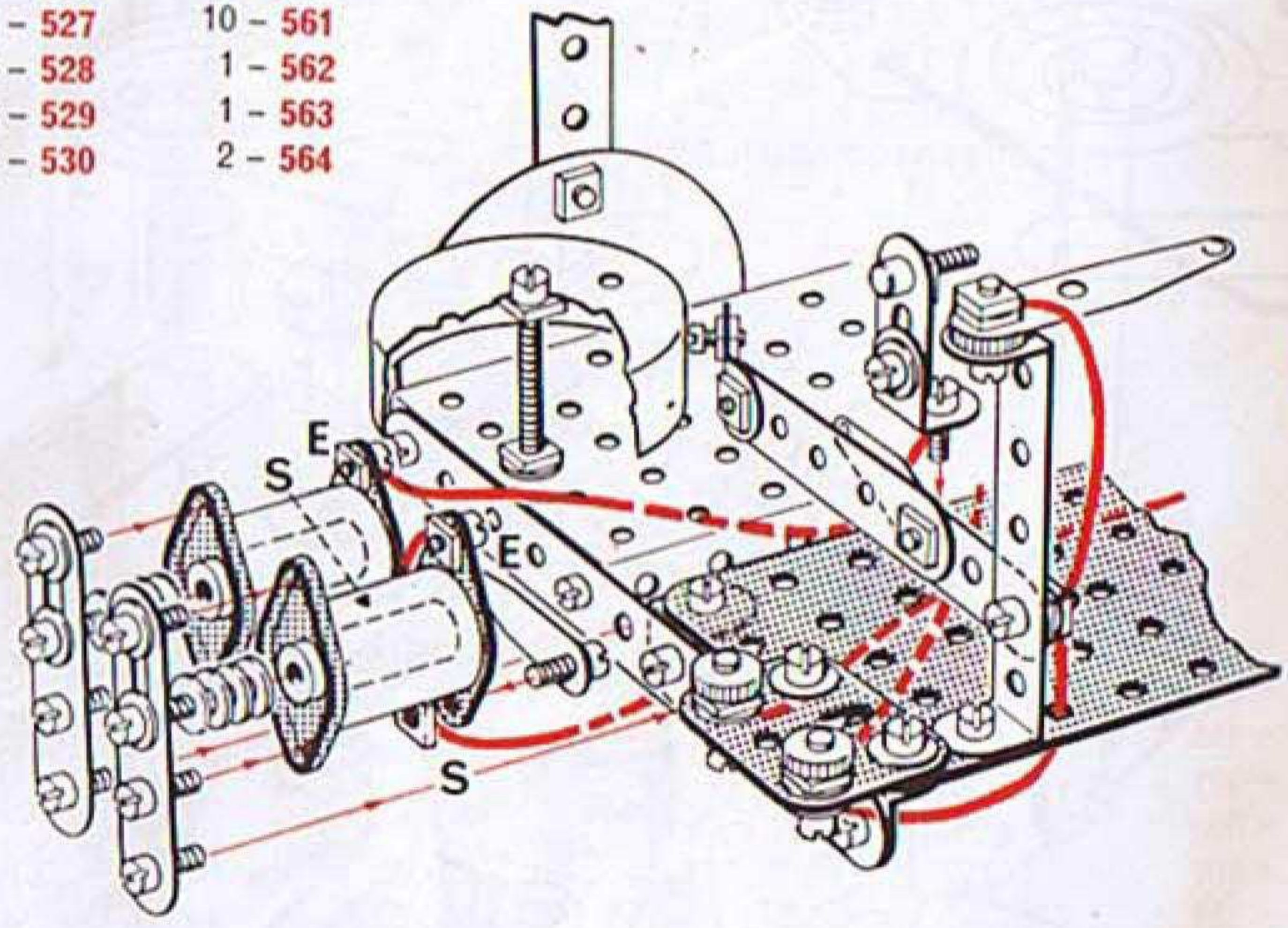

For part numbers see E33

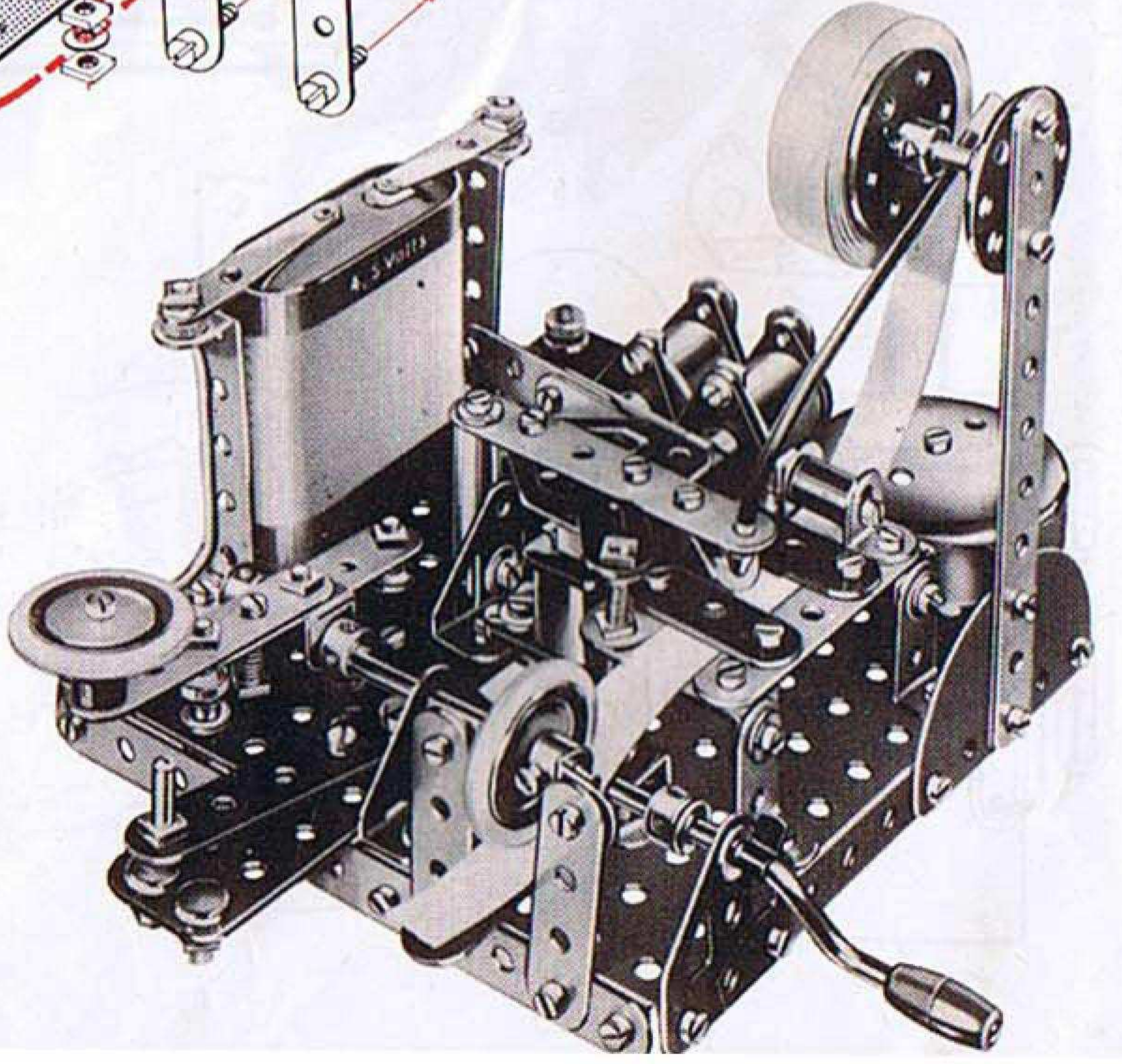

Receiving post

Transmitting post

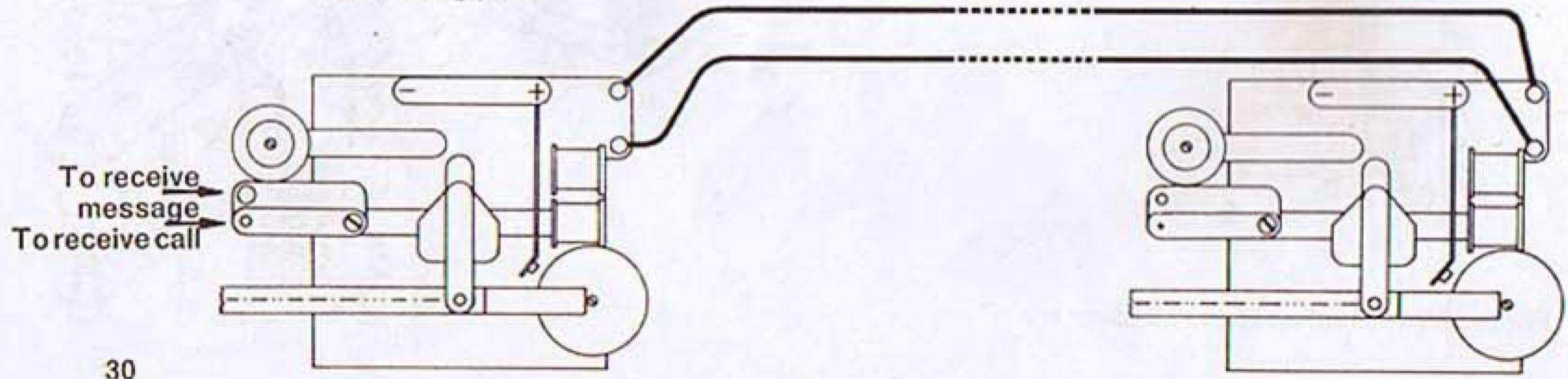

E35 Windmill (with illuminated sails)

The nuts and bolts holding the Lamp Holders to the sails and those connecting the sails to the centre wheel must be screwed up tight and it may even be necessary to scrape a little paint from the metal parts to ensure proper contact.

12-15v AC or DC.

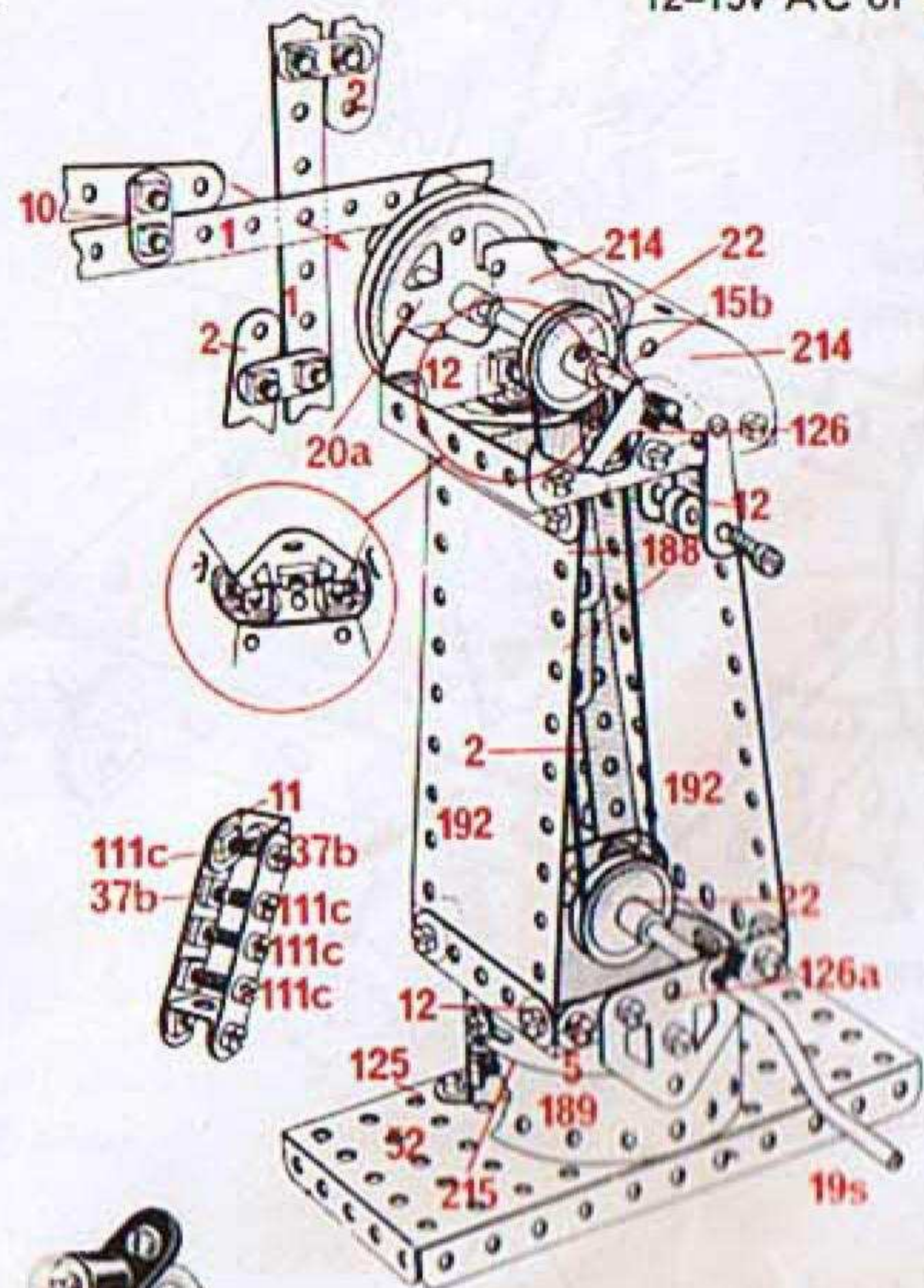

- | | |
|--------|--------|
| 2-1 | 2-125 |
| 6-2 | 2-126 |
| 8-5 | 2-126a |
| 4-10 | 2-188 |
| 2-11 | 2-189 |
| 9-12 | 1-191 |
| 1-15b | 2-192 |
| 1-19s | 2-214 |
| 1-20a | 4-215 |
| 3-22 | 4-221 |
| 2-35 | 1-508 |
| 72-37a | 1-513 |
| 59-37b | 1-533 |
| 11-38 | 4-539 |
| 1-40 | 4-540 |
| 2-48a | 2-542 |
| 1-52 | 4-544 |
| 1-140y | 1-551 |
| 2-90a | 3-561 |
| 2-111a | |
| 7-111c | |

E36 Crane with Electromagnetic Grab

This model shows how effectively Meccano standard parts and Meccano electrical parts can be combined to make more interesting and exciting models.

To build this model, extra parts are required as detailed on page 2 of cover.

The electromagnet and switch are models E5 and E1 in this book.

4-5v battery.

6-15v AC or DC.

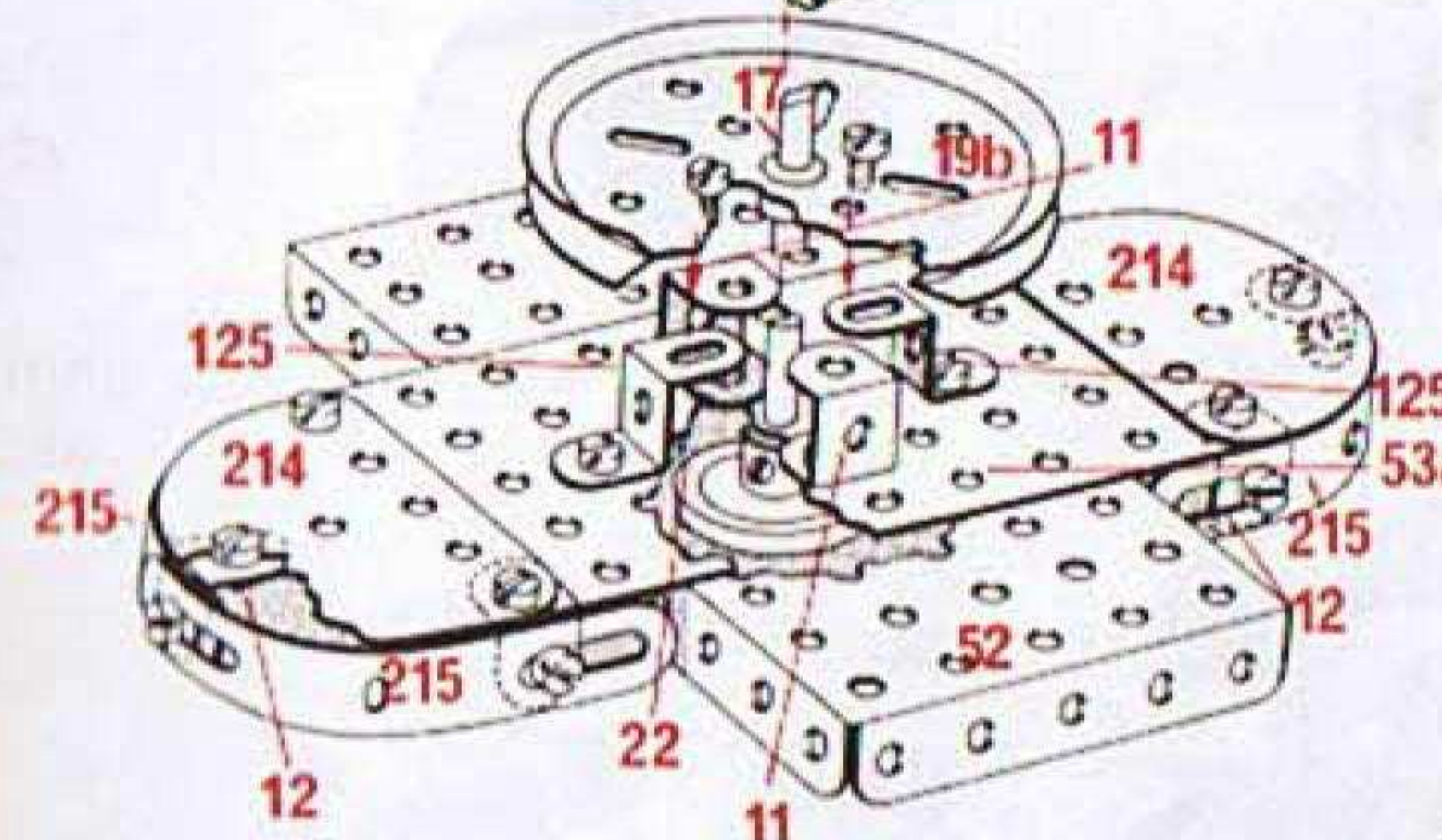
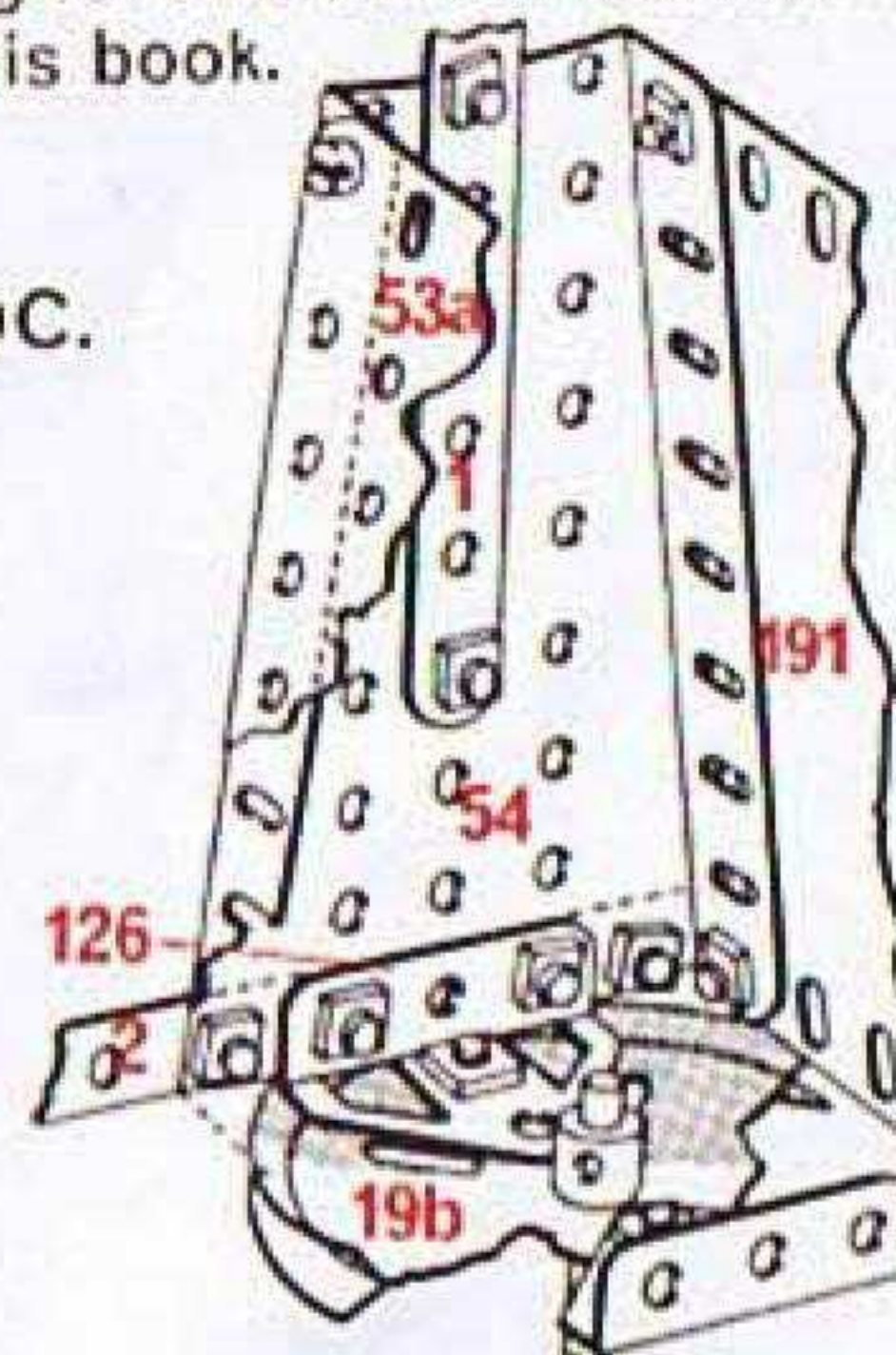

- | | |
|---------|--------|
| 4-1 | 2-54 |
| 8-2 | 1-59 |
| 2-3 | 4-111a |
| 8-5 | 5-111c |
| 6-10 | 1-111d |
| 2-11 | 2-125 |
| 1-11a | 2-126 |
| 9-12 | 1-147b |
| 2-12b | 1-176 |
| 1-16 | 1-186 |
| 1-17 | 1-191 |
| 1-18a | 2-214 |
| 1-18b | 4-215 |
| 2-19b | 4-221 |
| 1-19s | 1-502 |
| 1-20a | 1-511 |
| 3-22 | 2-513 |
| 2-22a | 1-514 |
| 6-35 | 2-520 |
| 83-37b | 2-525 |
| 103-37a | 2-526 |
| 34-38 | 1-529 |
| 2-38d | 1-533 |
| 1-40 | 5-542 |
| 1-48 | 3-544 |
| 6-48a | 4-561 |
| 1-52 | 1-562 |
| 2-53a | 1-564 |

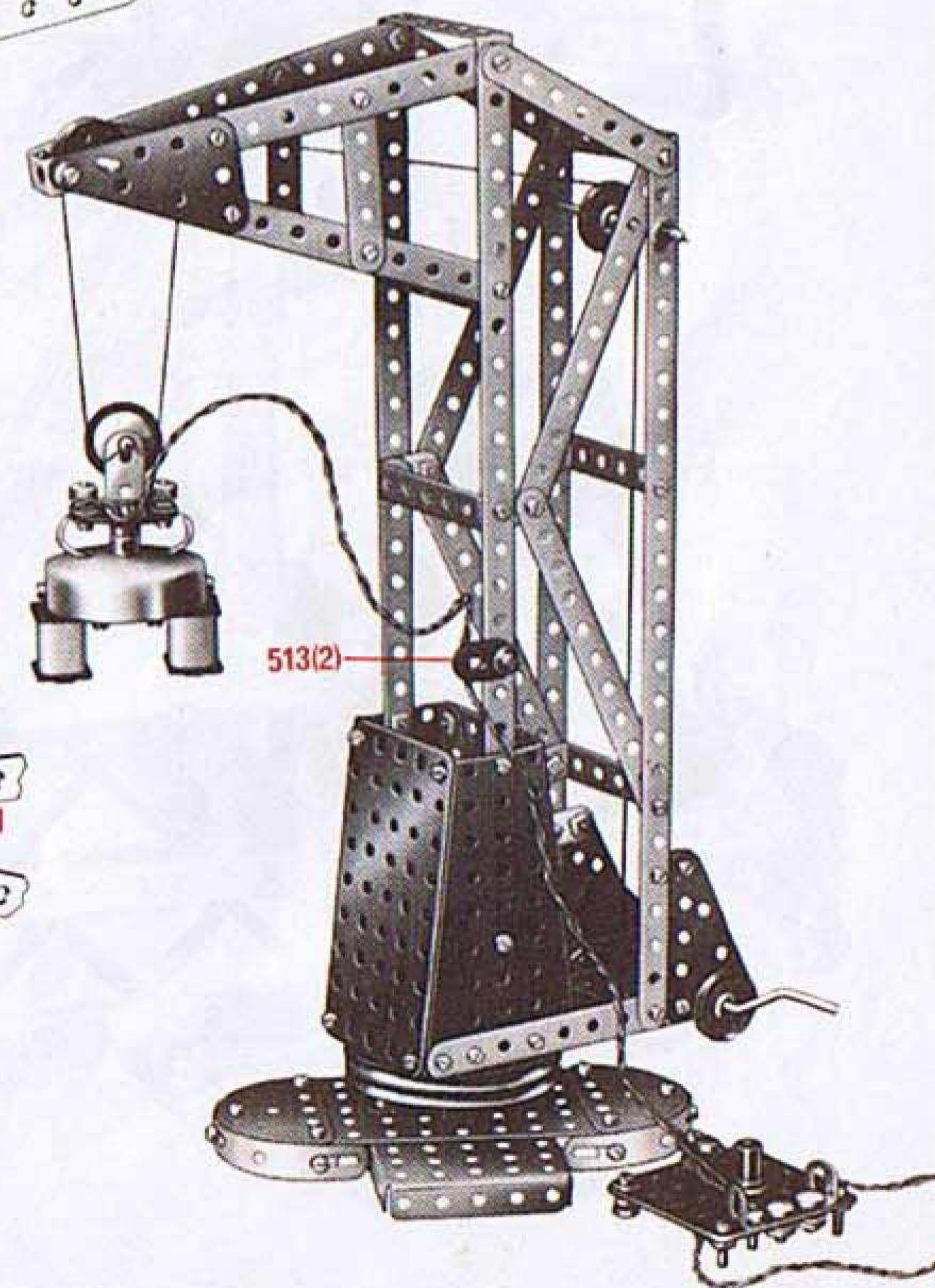
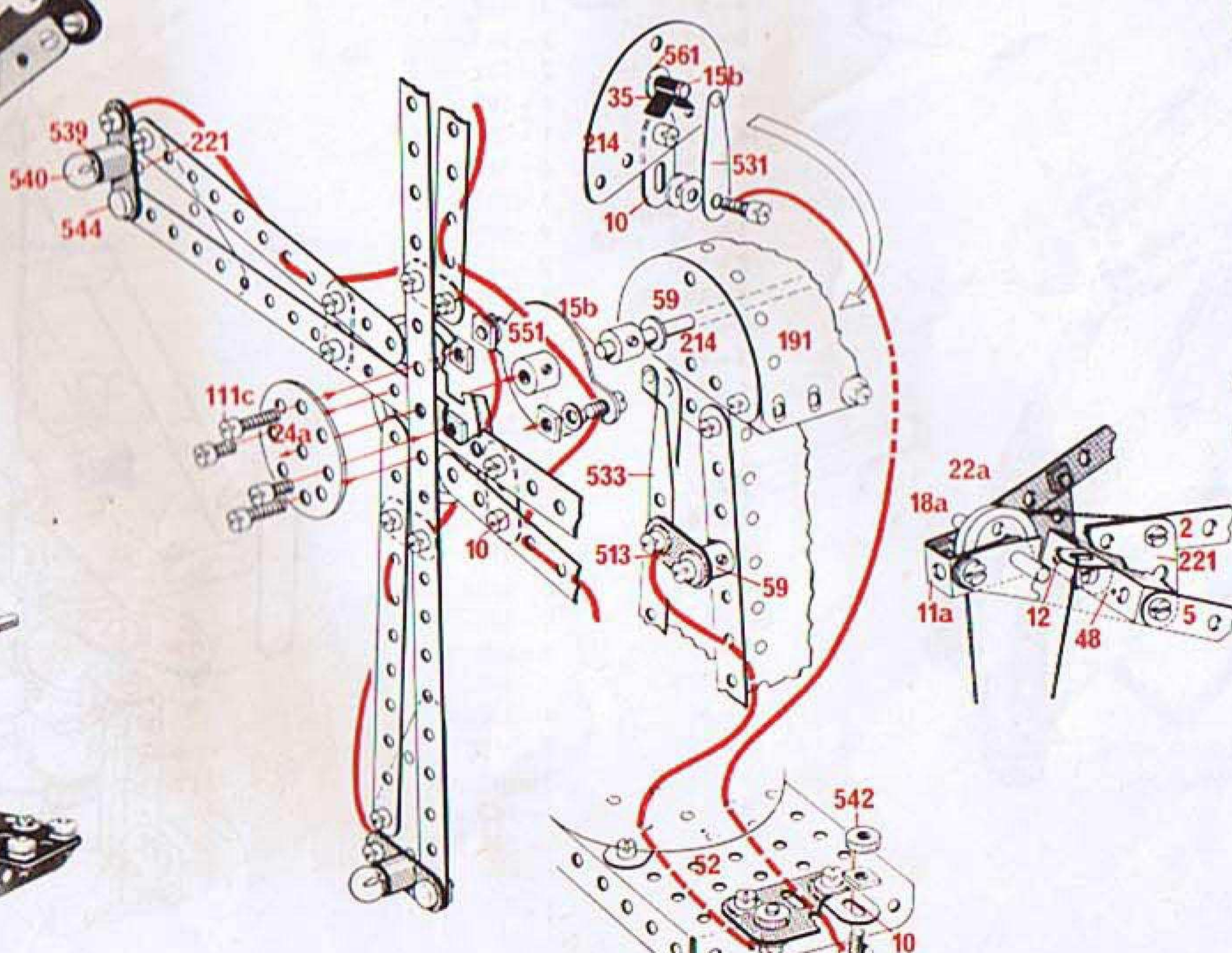
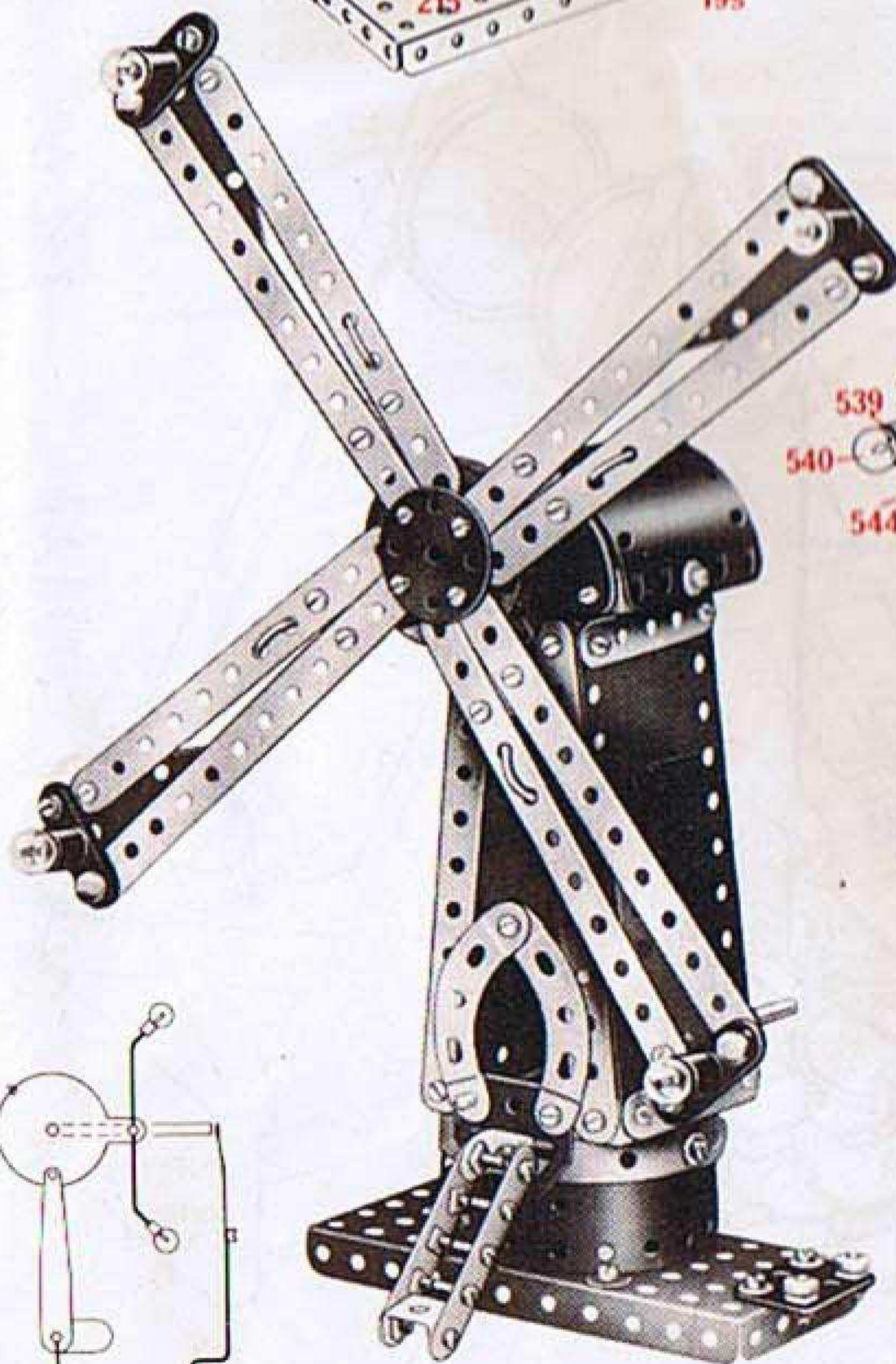

E37 Electrically Driven Big Wheel with Lights

This model incorporates motor E21 with a slight alteration to the vertical members of the frame.

X These nuts and bolts should be screwed up tight and it may even be necessary to scrape a little paint from the parts to ensure proper contact.

Y Wires leading from the frame side of the holders back to Bolt X.

Z Wires leading from the Commutator to the holes in the lamp holders *not* connected to the frame.

To build this model extra parts are required as detailed on page 2 of cover.

12 volts — DC only.

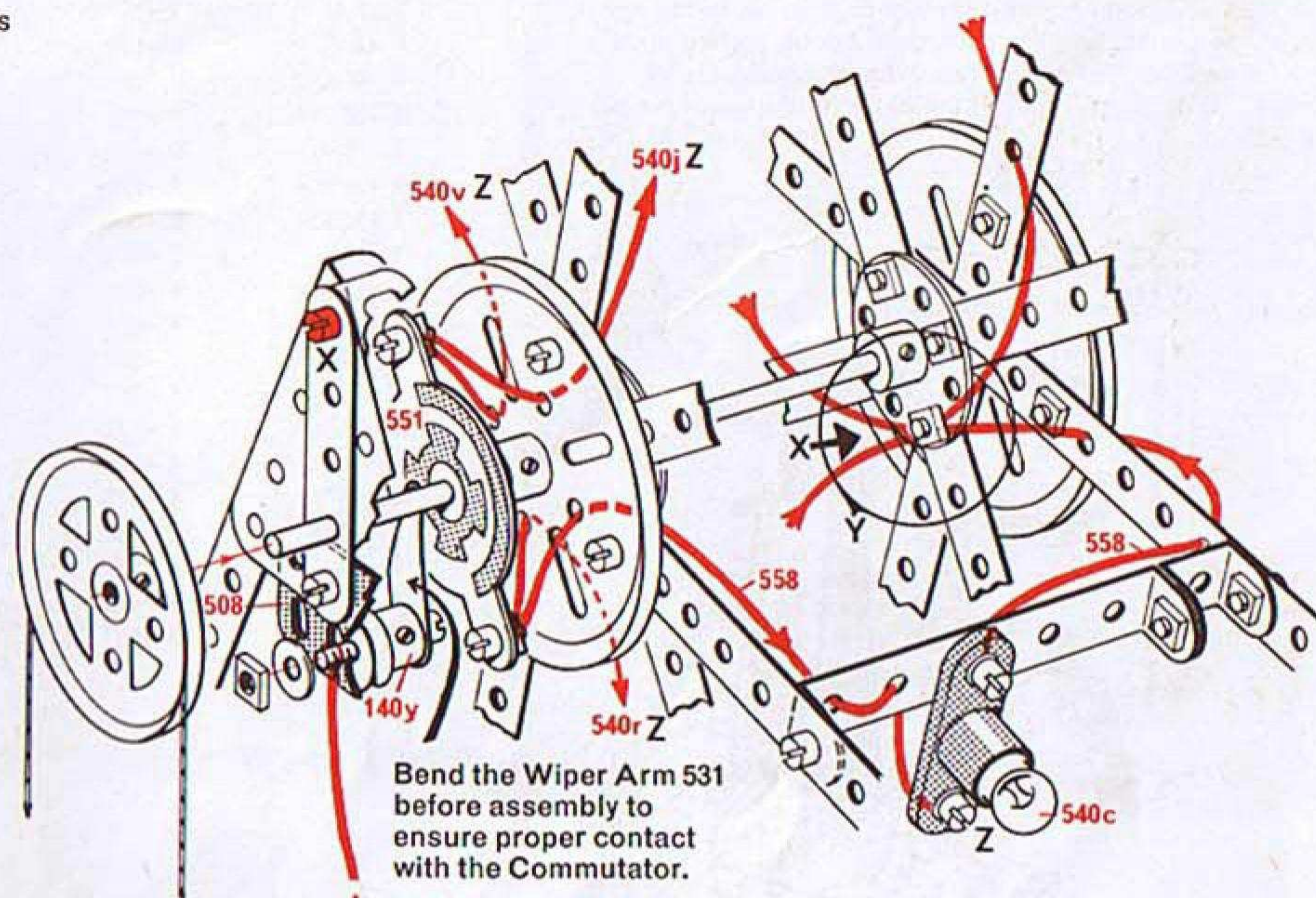
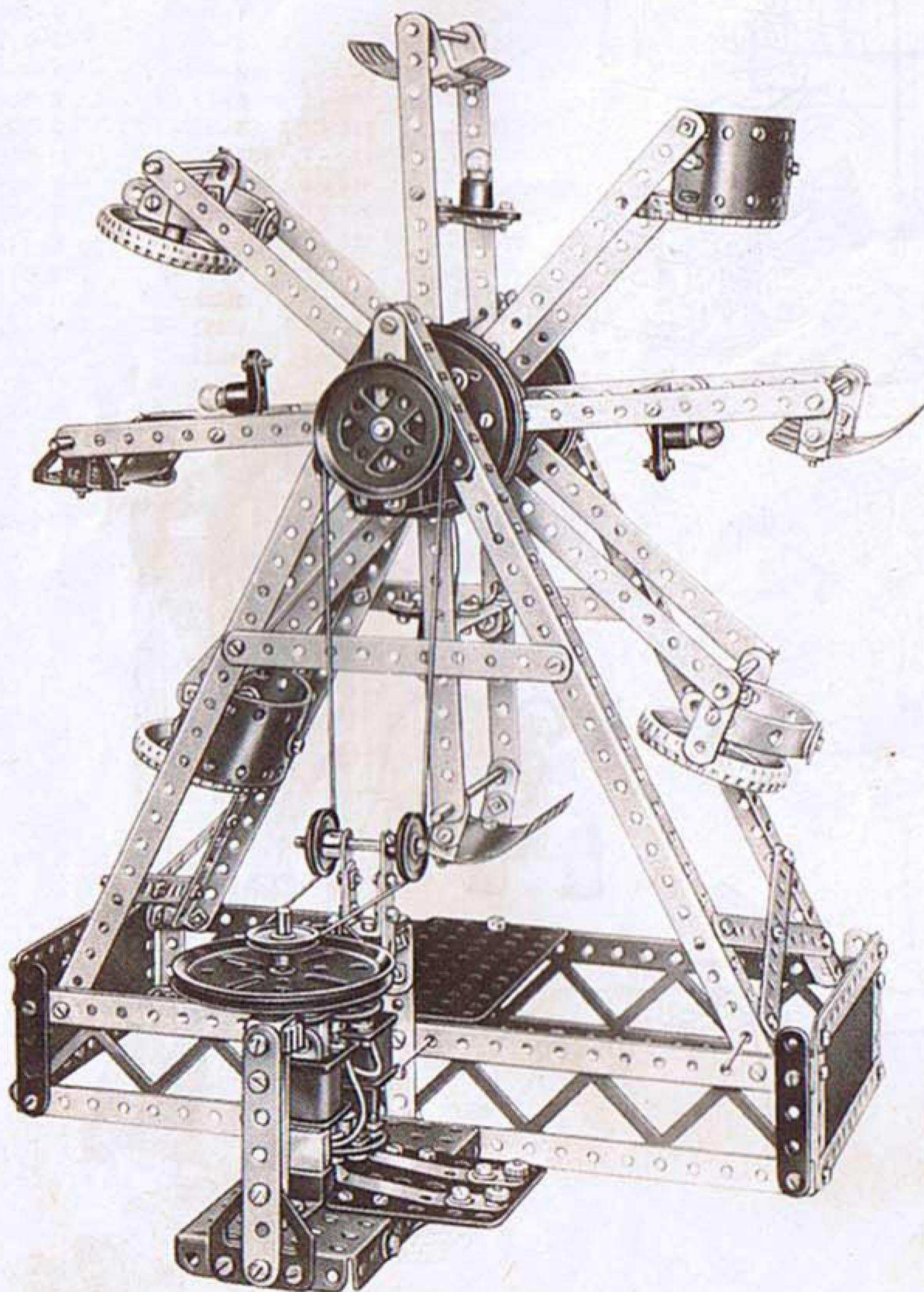

- | | |
|-----------|----------|
| 10 - 1 | 1 - 111 |
| 14 - 2 | 2 - 111a |
| 2 - 3 | 2 - 126 |
| 12 - 5 | 1 - 126a |
| 2 - 6a | 4 - 187 |
| 4 - 8 | 4 - 188 |
| 6 - 10 | 2 - 190 |
| 4 - 11 | 2 - 192 |
| 1 - 11a | 1 - 199 |
| 14 - 12 | 1 - 200 |
| 2 - 12a | 4 - 215 |
| 1 - 15 | 4 - 221 |
| 1 - 15a | 2 - 501 |
| 2 - 15b | 2 - 502 |
| 4 - 16 | 1 - 508 |
| 2 - 17 | 1 - 510 |
| 3 - 19b | 1 - 511 |
| 1 - 20a | 1 - 514 |
| 3 - 22 | 2 - 520 |
| 1 - 23 | 2 - 525 |
| 2 - 24 | 2 - 526 |
| 1 - 26 | 2 - 529 |
| 14 - 35 | 1 - 531 |
| 173 - 37a | 2 - 533 |
| 143 - 37b | 2 - 537 |
| 29 - 38 | 2 - 538 |
| 2 - 38d | 4 - 539 |
| 1 - 40 | 4 - 540 |
| 1 - 45 | 2 - 542 |
| 1 - 46 | 8 - 544 |
| 8 - 48a | 1 - 545 |
| 1 - 52 | 1 - 548 |
| 2 - 80c | 1 - 551 |
| 2 - 99 | 2 - 561 |

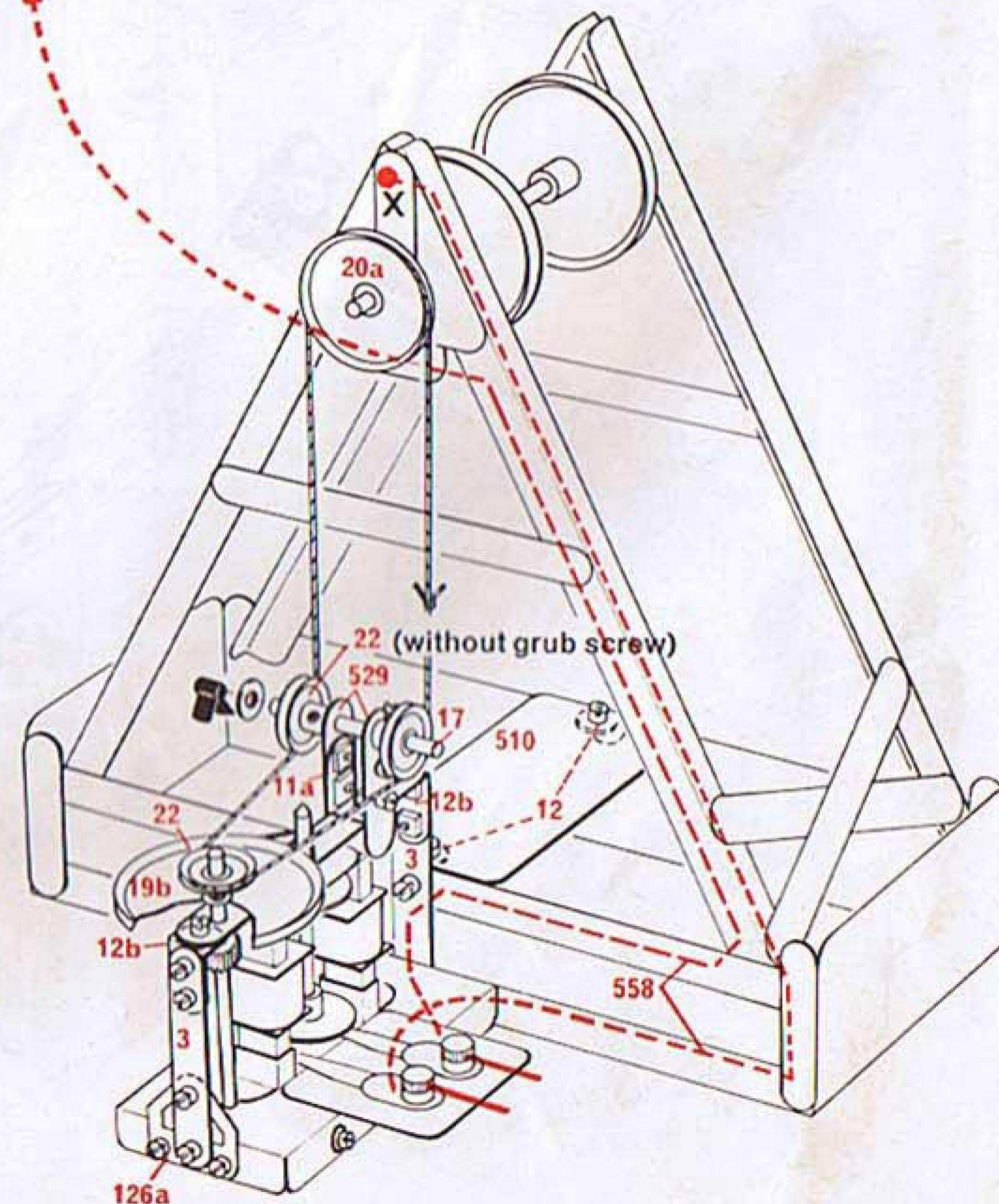

Principal Meccano standard parts used in the models in this book

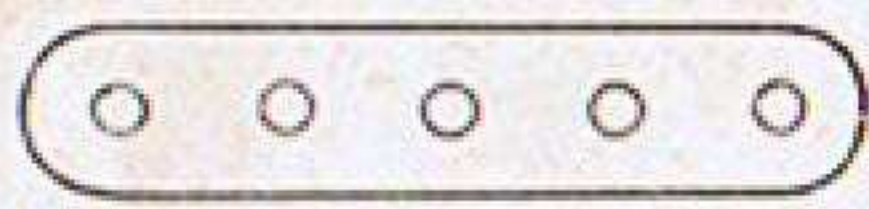

5

Perforated Strip
2 1/2"



10

Fishplate

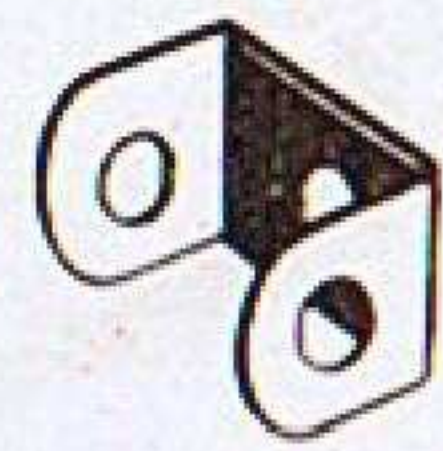

11

Double
Bracket



12

Angle
Bracket

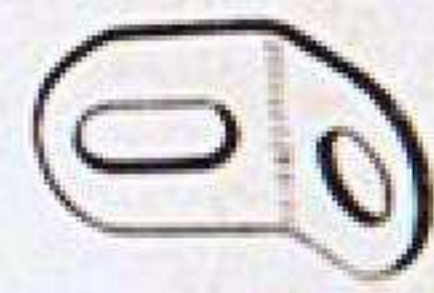

12c

Obtuse Angle
Bracket



17

Axle Rod
2"

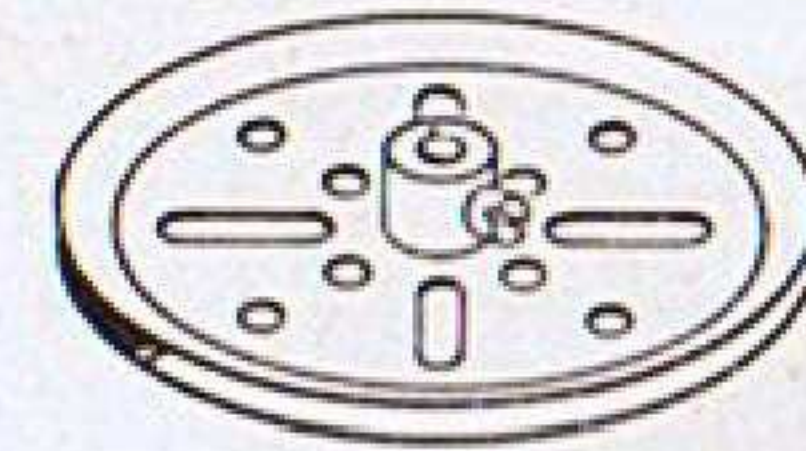

19b

Pulley 3" diam.
with boss



19s

Crank Handle
3 1/2" shaft

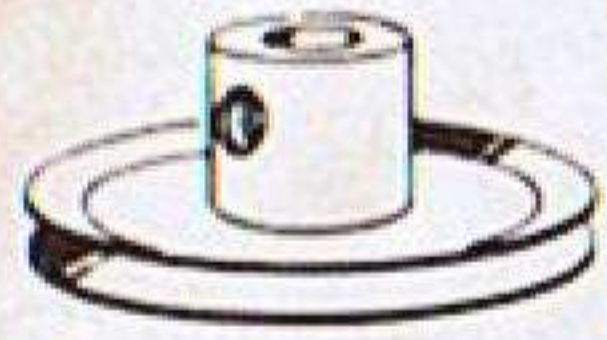

22

Pulley 1" diam.
with boss



22a

Pulley 1" diam.
without boss



23

Pulley 1/2" diam.
without boss



24

Bush Wheel
1 3/8" diam.
8 holes

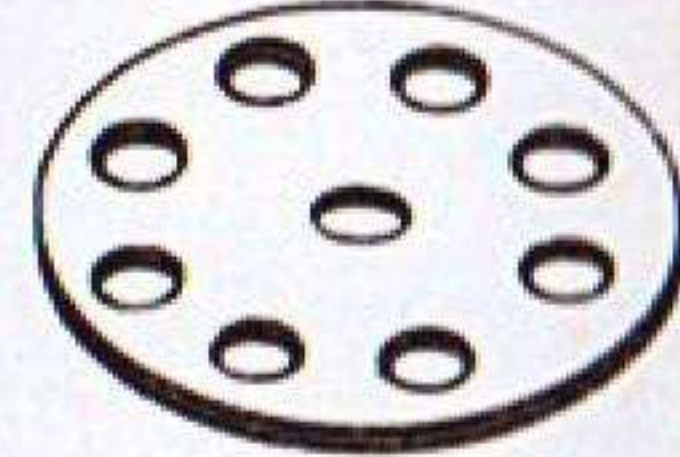

24a

Wheel Disc
1 3/8" diam.
8 holes
without boss



35

Spring
Clip

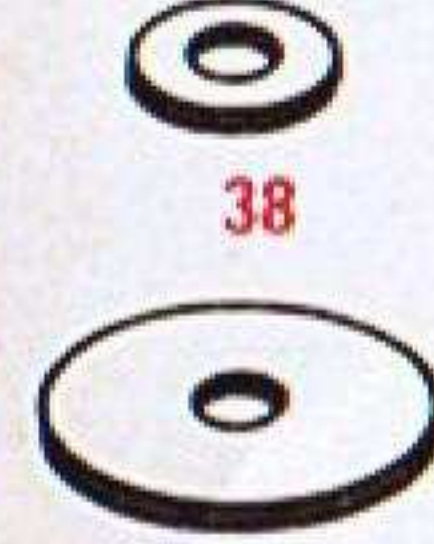

38d

Washer
Washer 3/4"

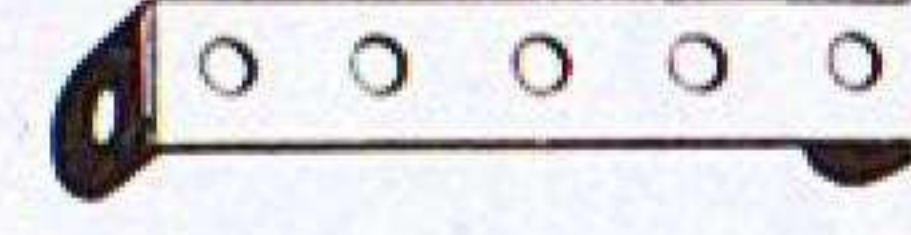

48a

Double Angle
Strip 2 1/2" x 1/2"

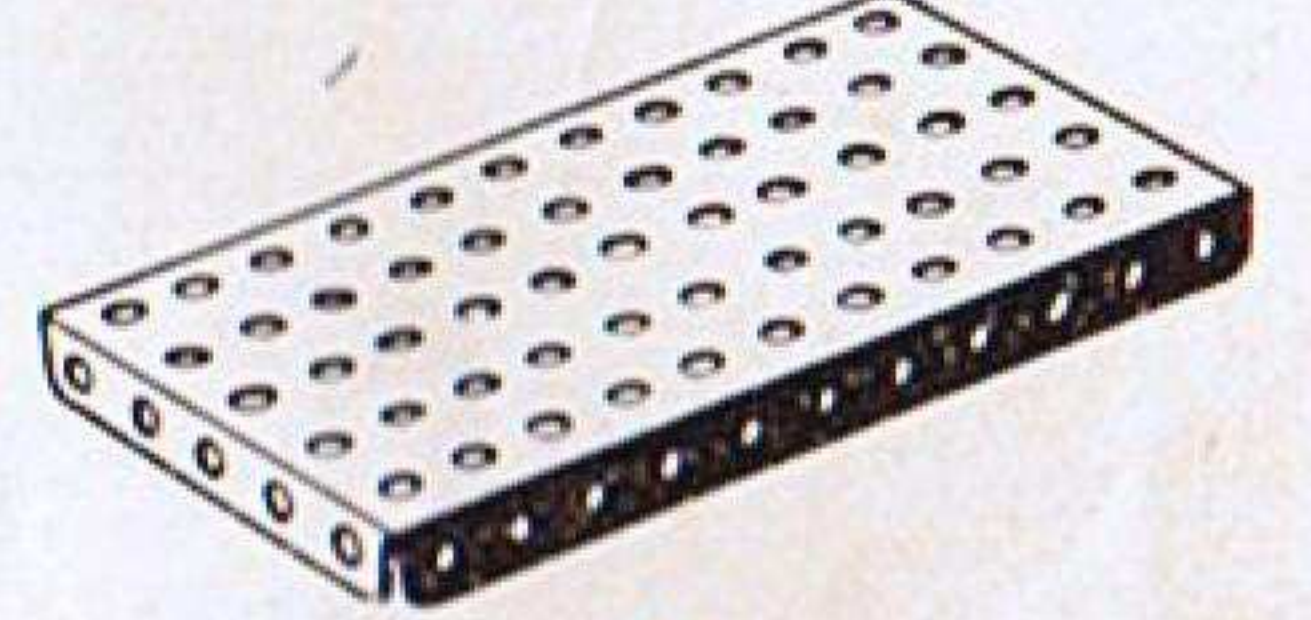

52

Flanged Plate
5 1/2" x 2 1/2"



59

Collar
with
screw



90a

Stepped Curved
Strip 2 1/2" (1 3/8" radius)

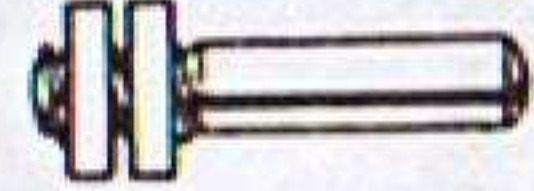

115

Threaded
Pin



120b

Compression
Spring 2/16" long



125

Reversed
Angle
Bracket
1/2"

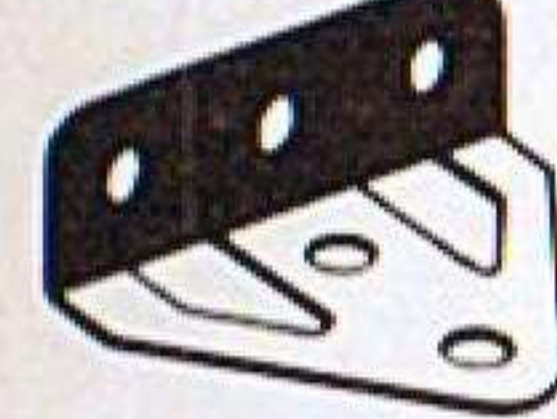

126

Trunnion

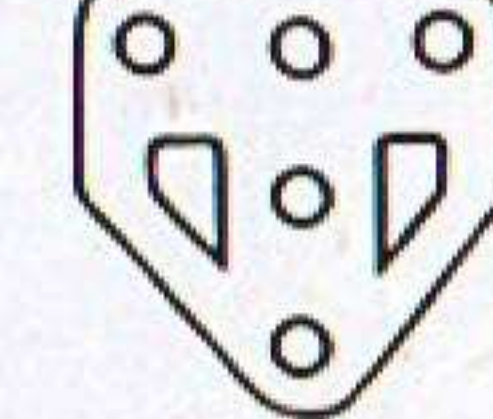

126a

Flat
Trunnion



140y

Collar
4 holes

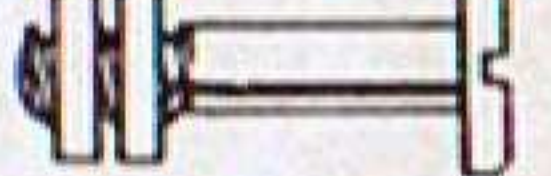

147b

Pivot Bolt
with 2 nuts

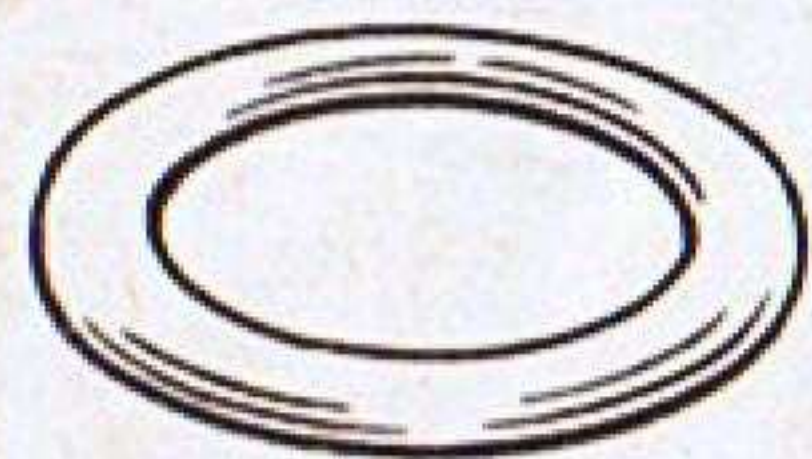

155

Rubber Ring
for 1" pulley



176

Anchoring
Spring
for cord

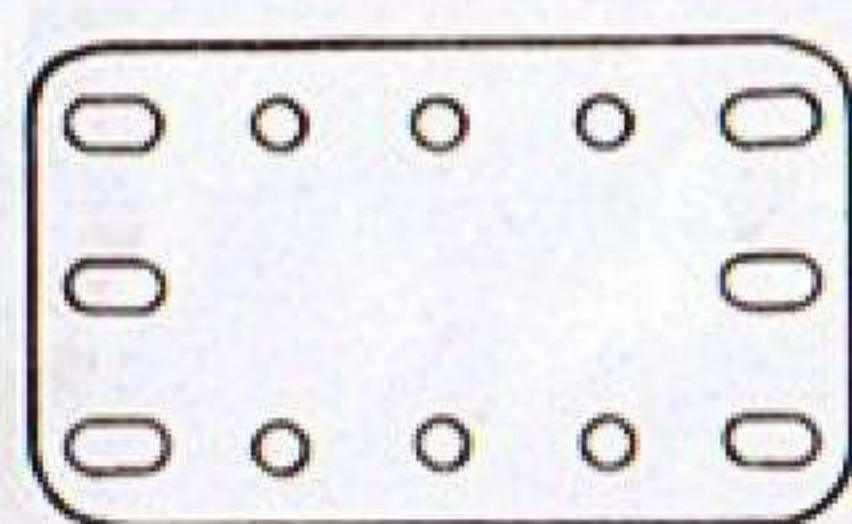

188

Flexible
Plate 2 1/2" x 1 1/2"



212

Rod and
Strip
Connector



213

Rod
Connector

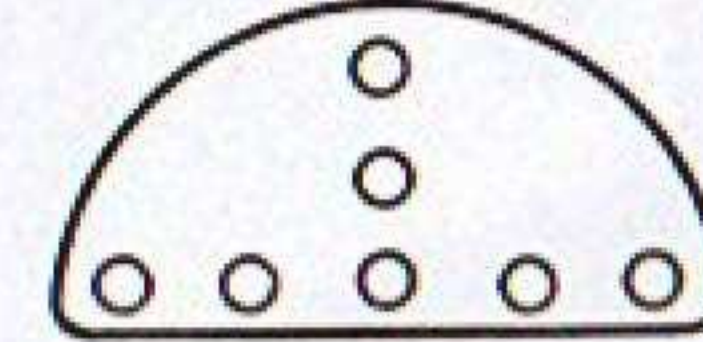

214

Semi Circular
Plate 2 1/2"



215

Formed
Slotted
Strip 3"

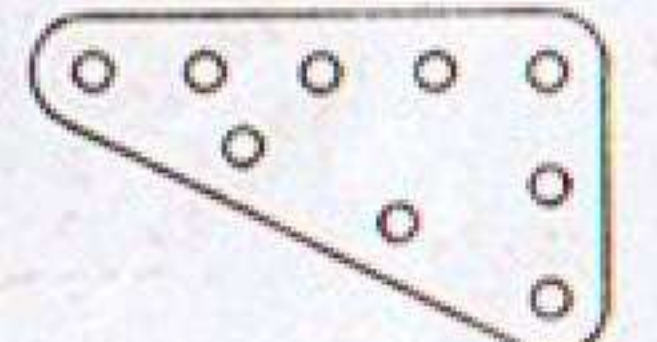

221

Triangular
Flexible
Plate 2 1/2" x 1 1/2"

Meccano Electrical Parts

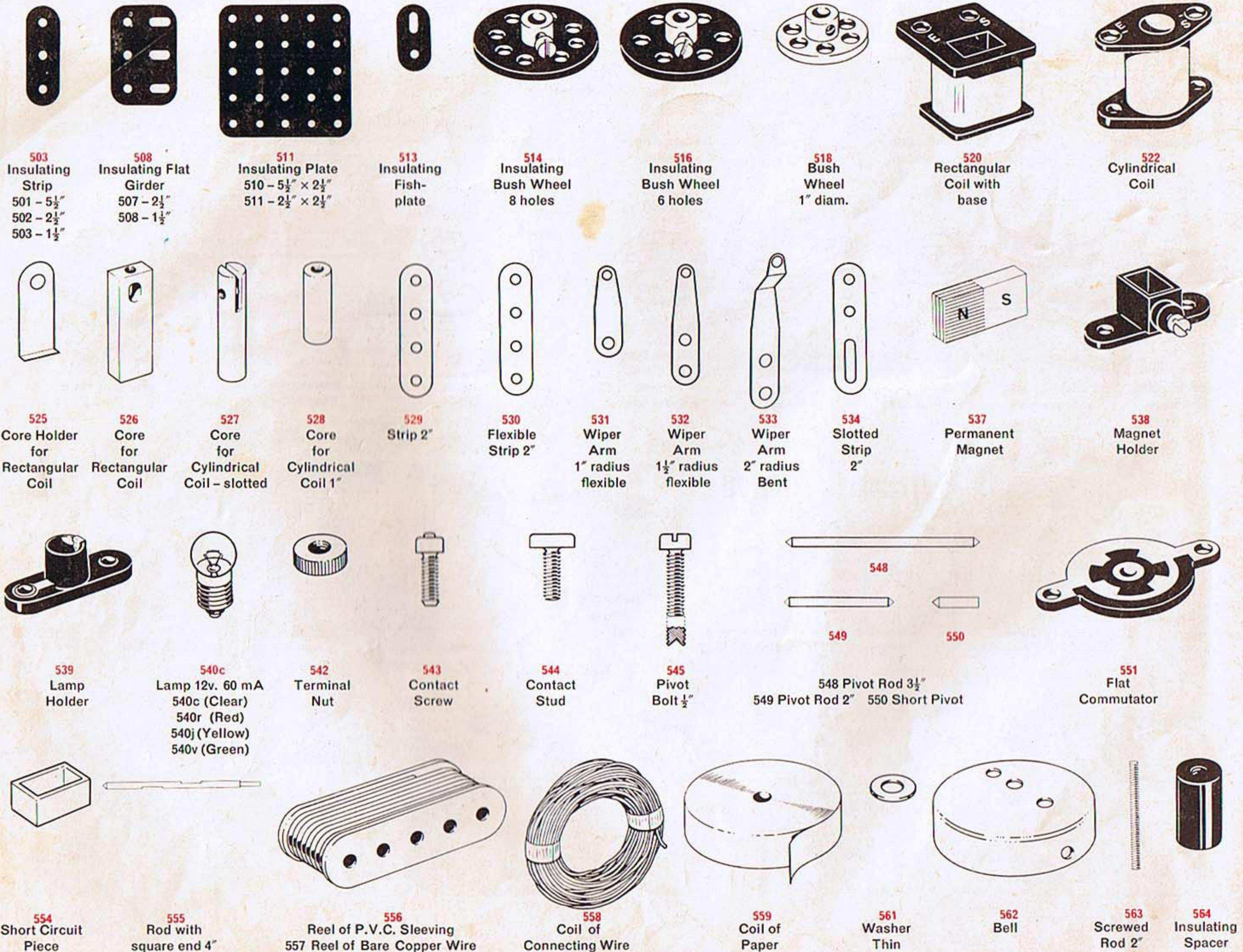

503 Insulating Strip
 501 - 5½"
 502 - 2½"
 503 - 1½"
508 Insulating Flat Girder
 507 - 2½"
 508 - 1½"
511 Insulating Plate
 510 - 5½" x 2½"
 511 - 2½" x 2½"
513 Insulating Fish-plate
514 Insulating Bush Wheel 8 holes
516 Insulating Bush Wheel 6 holes
518 Bush Wheel 1" diam.
520 Rectangular Coil with base
522 Cylindrical Coil
525 Core Holder for Rectangular Coil
526 Core for Rectangular Coil
527 Core for Cylindrical Coil - slotted
528 Core for Cylindrical Coil 1"
529 Strip 2"
530 Flexible Strip 2"
531 Wiper Arm 1" radius flexible
532 Wiper Arm 1½" radius flexible
533 Wiper Arm 2" radius Bent
534 Slotted Strip 2"
537 Permanent Magnet
538 Magnet Holder
539 Lamp Holder
540c Lamp 12v. 60 mA
 540c (Clear)
 540r (Red)
 540j (Yellow)
 540v (Green)
542 Terminal Nut
543 Contact Screw
544 Contact Stud
545 Pivot Bolt ½"
548 Pivot Rod 3½"
549 Pivot Rod 2"
550 Short Pivot
551 Flat Commutator
554 Short Circuit Piece
555 Rod with square end 4"
556 Reel of P.V.C. Sleeving
557 Reel of Bare Copper Wire
558 Coil of Connecting Wire
559 Coil of Paper
561 Washer Thin
562 Bell
563 Screwed Rod 2"
564 Insulating Spacer