

MECCANO®

MANUEL D'INSTRUCTIONS

5

PIÈCES DÉTACHÉES MECCANO

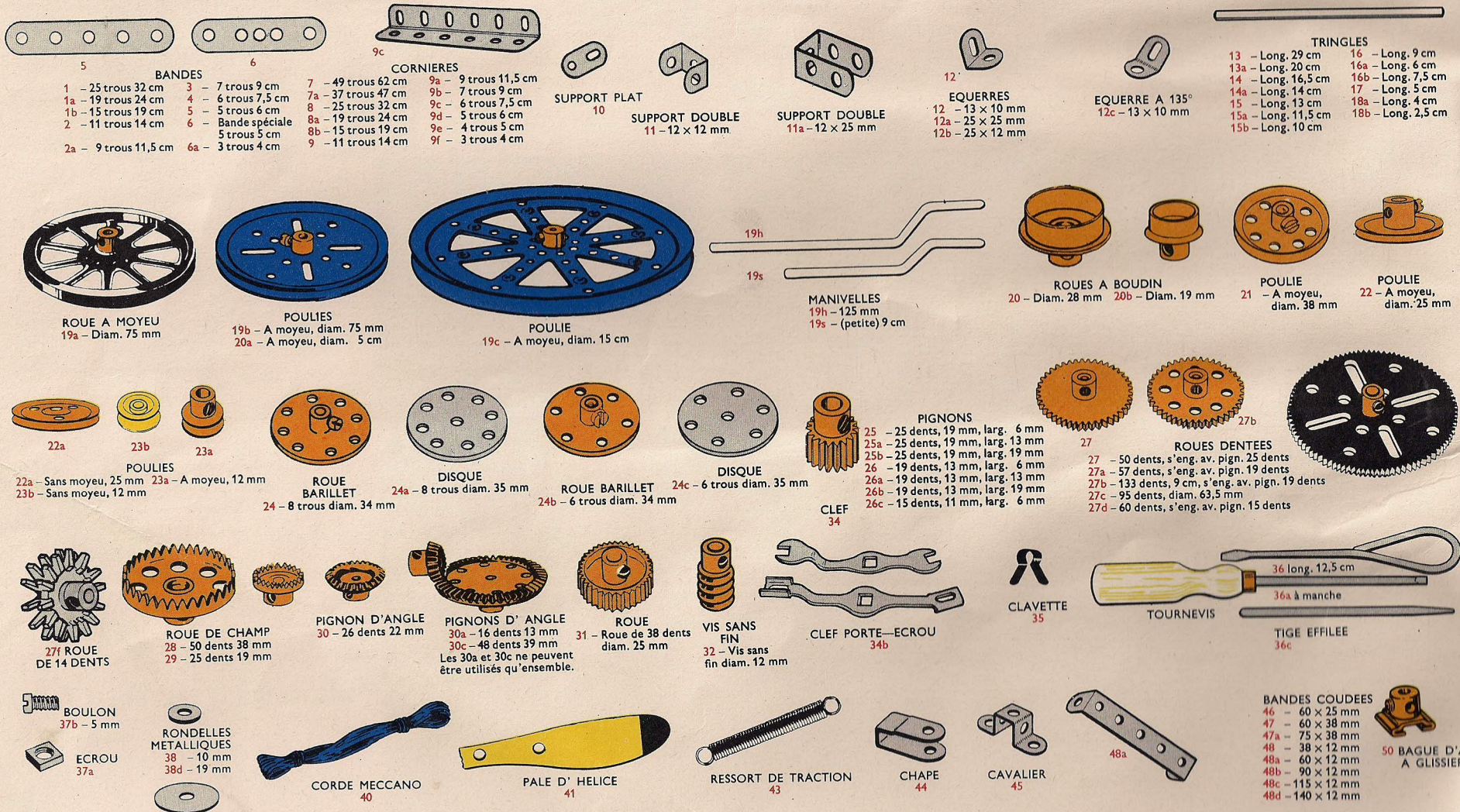

5.1

Ferry boat

4- 1	2- 35	2-126
8- 2	107- 37a	2-126a
2- 3	93- 37b	4-142c
8- 5	11- 38	2-155
3-10	2- 38d	2-188
2-11	1- 40	2-189
1-11a	2- 48	4-190
10-12	5- 48a	2-191
1-12c	1- 51	2-192
4-16	1- 52	1-193
1-18a	2- 53a	2-194
1-18b	2- 54	1-212
4-22	2- 90a	2-212a
2-22a	2-111	2-214
1-23	4-111c	4-221
2-24	2-125	

4- 1	1- 40
7- 2	3- 48a
2- 3	1- 51
6- 5	2- 53a
1-10	2- 54
2-11	2- 90a
1-11a	1-111
10-12	2-111c
1-12c	2-125
2-16	2-126
1-18a	4-142c
1-18b	2-188
4-22	2-189
2-22a	4-190
1-23	2-191
1-24	2-192
81- 37a	1-212
73- 37b	1-212a
10-38	2-214
1-38d	4-221

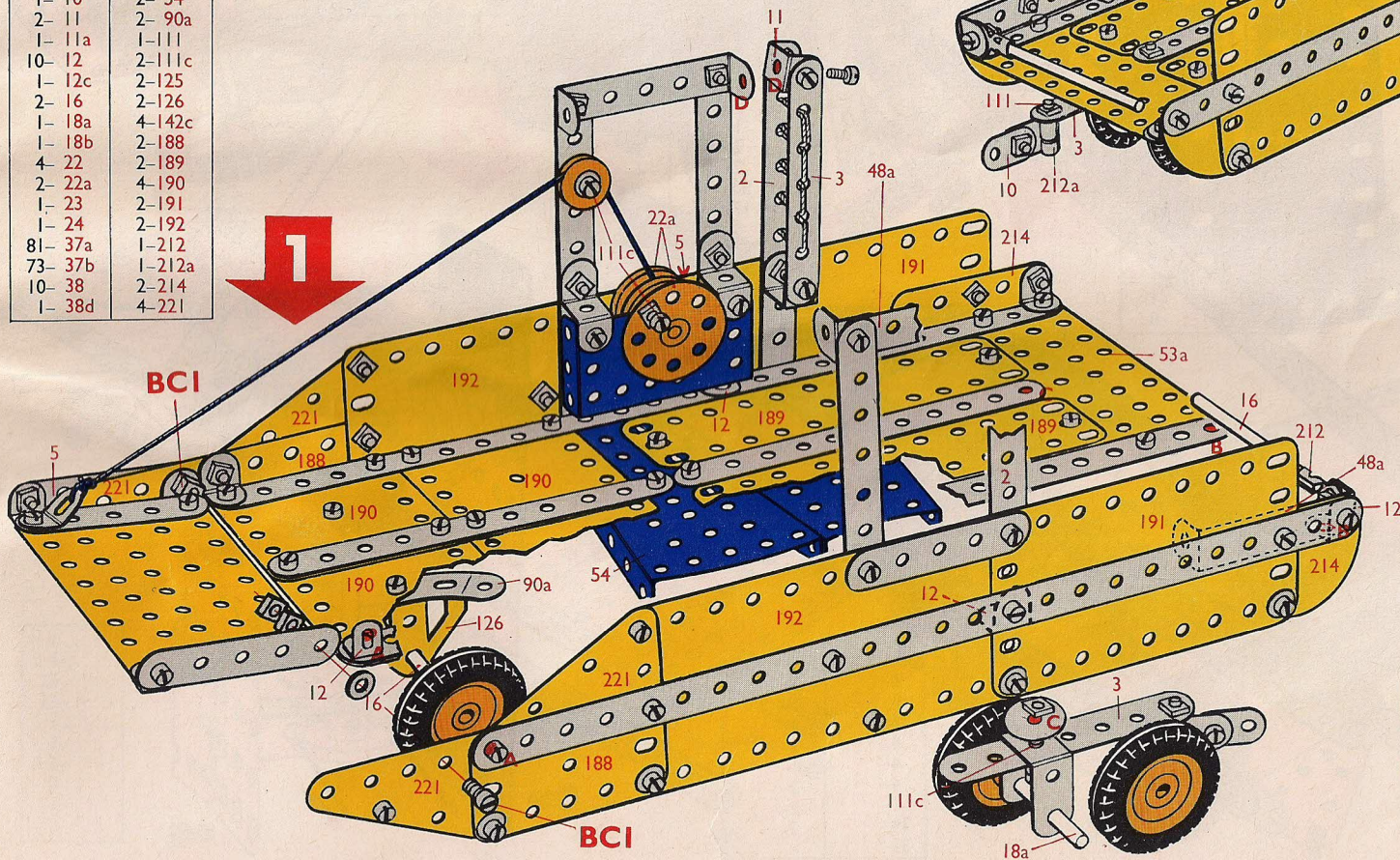
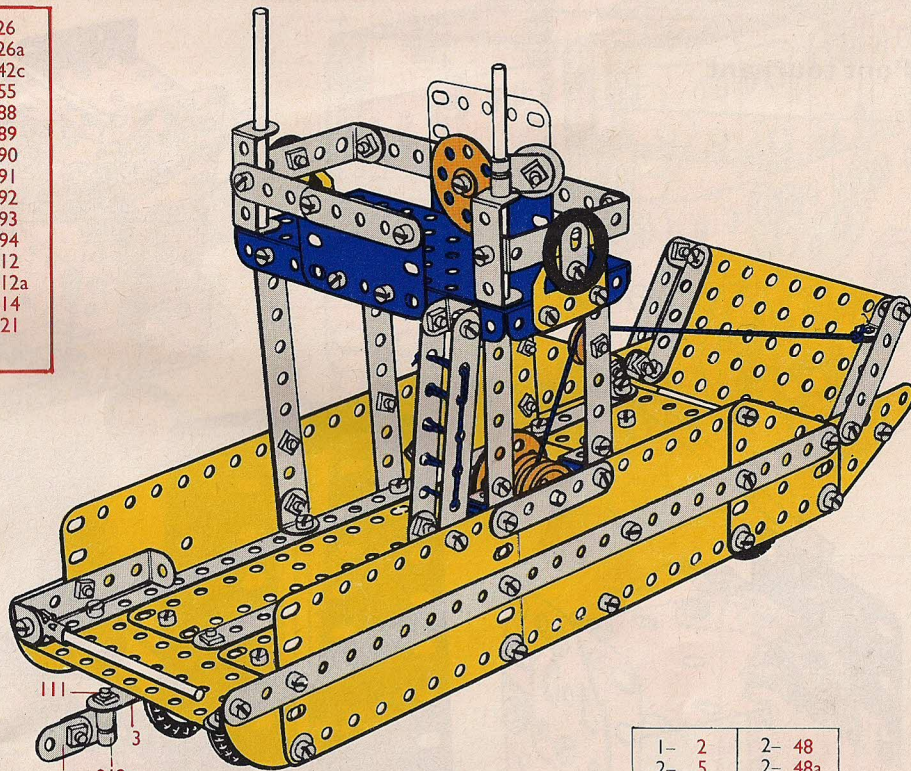

1- 2	2- 48
2- 5	2- 48a
2-10	1- 52
2-16	1-111
1-24	2-111c
2-35	2-126a
26-37a	2-155
20-37b	1-193
1-38	2-194
1-38d	1-212a

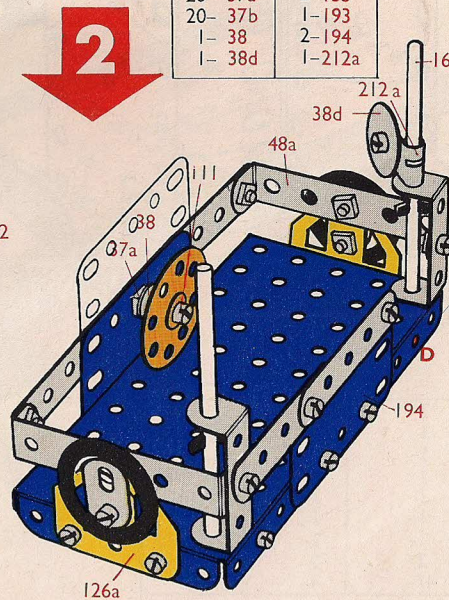

5.2

Pont tournant

4-	1	2-	24	4-	111c
8-	2	2-	27f	2-	125
2-	3	4-	35	2-	126
9-	5	101-	37a	2-	126a
4-	10	93-	37b	2-	188
1-	11	13-	38	2-	189
9-	12	1-	40	4-	190
2-	12c	6-	48a	2-	191
1-	15b	1-	51	2-	192
3-	16	1-	52	2-	194
1-	19s	2-	53a	2-	212a
1-	20a	2-	54	2-	214
3-	22	4-	90a	4-	221
1-	23a	2-	111a		

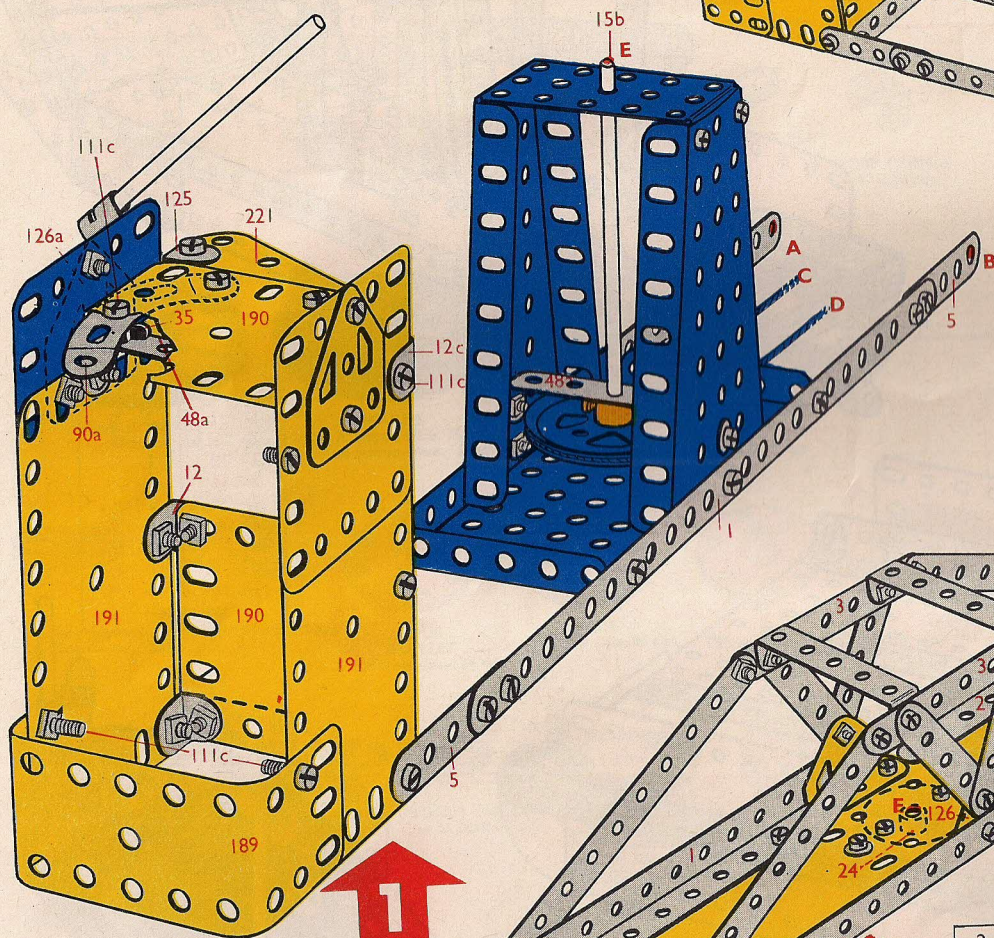
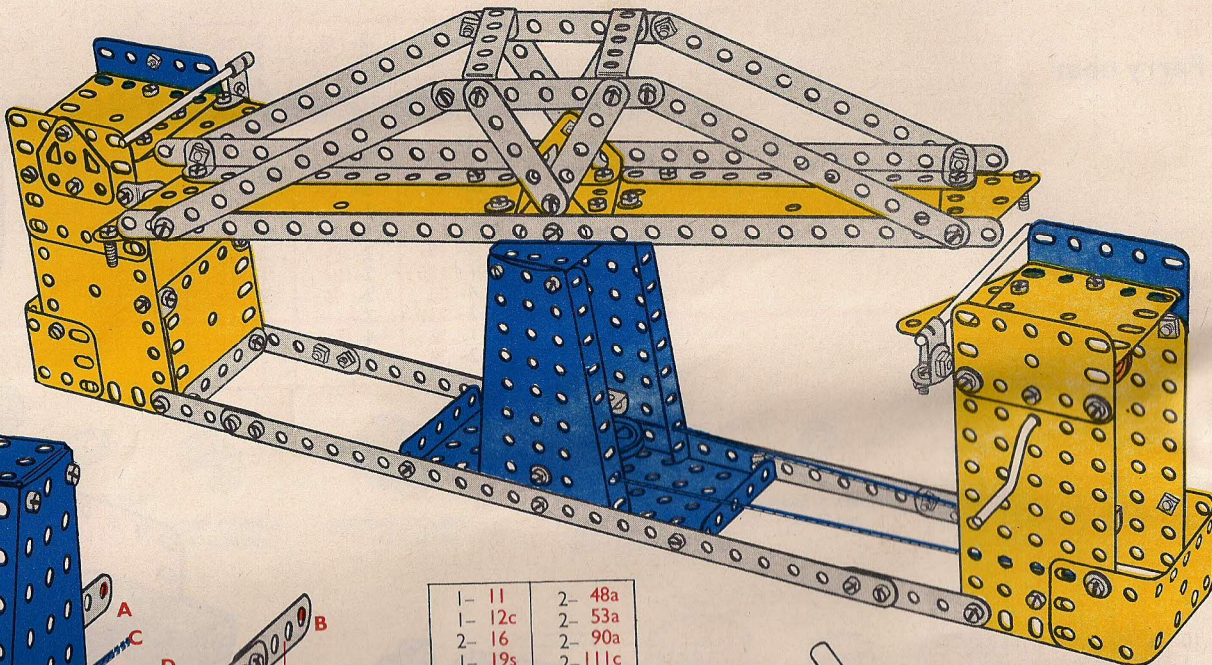

1-	11	2-	48a
1-	12c	2-	53a
2-	16	2-	90a
1-	19s	2-	111c
3-	22	1-	125
1-	23a	1-	188
1-	24	1-	189
2-	27f	1-	190
2-	35	1-	194
20-	37a	1-	212a
17-	37b	1-	221
9-	38		

2-	1	44-	37b	1-	125
5-	5	2-	38	2-	126a
5-	12	1-	40	1-	189
1-	12c	2-	48a	3-	190
1-	15b	1-	51	2-	191
1-	16	1-	52	1-	194
1-	20a	2-	54	1-	212a
2-	35	2-	90a	1-	221
47-	37a	4-	111c		

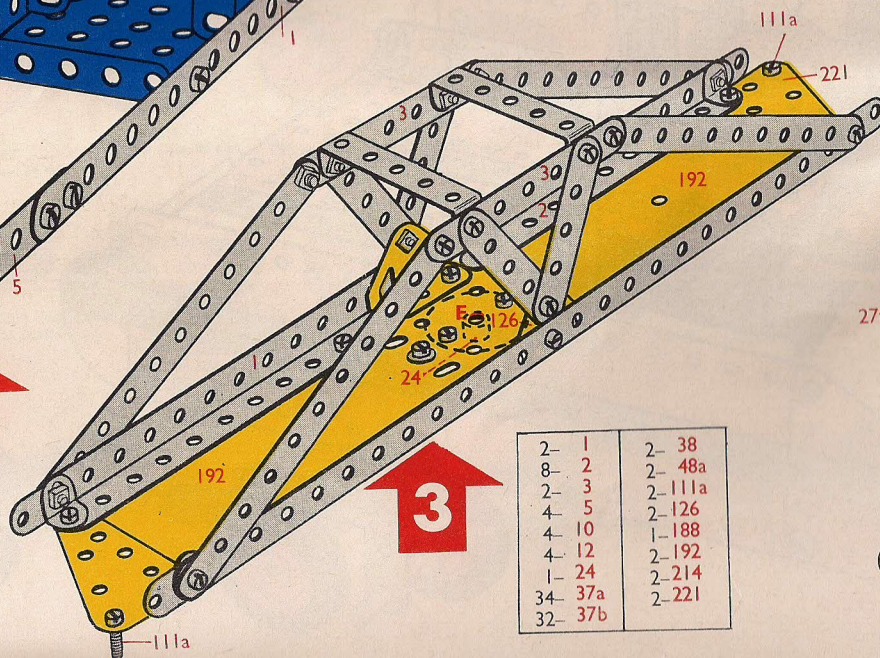

2-	1	2-	38
8-	2	2-	48a
2-	3	2-	111a
4-	5	2-	126
4-	10	1-	188
4-	12	2-	192
1-	24	2-	214
34-	37a	2-	221
32-	37b		

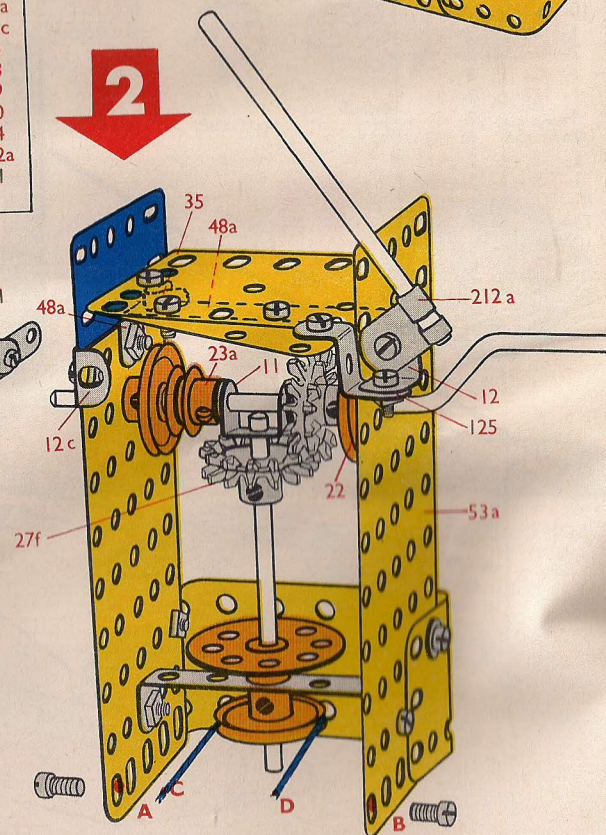

5.3 Camion gros porteur

4- 1	2- 22	1- 52	2-189
8- 2	2- 22a	2- 53a	4-190
2- 3	1- 23	3- 90a	2-191
9- 5	1- 23a	1-111	2-192
4-10	1- 24	1-111a	2-193
2-11	8- 35	6-111c	1-193a
1-11a	107-37a	2-125	2-194a
6-12	93-37b	2-126	2-212a
1-12c	14- 38	2-126a	1-213
2-16	2- 38d	1-155	2-214
2-17	2- 48	*1-186b	4-215
2-18a	6- 48a	4-187	4-221
1-18b	1- 51	2-188	*1-M2

* Non inclus dans la boîte

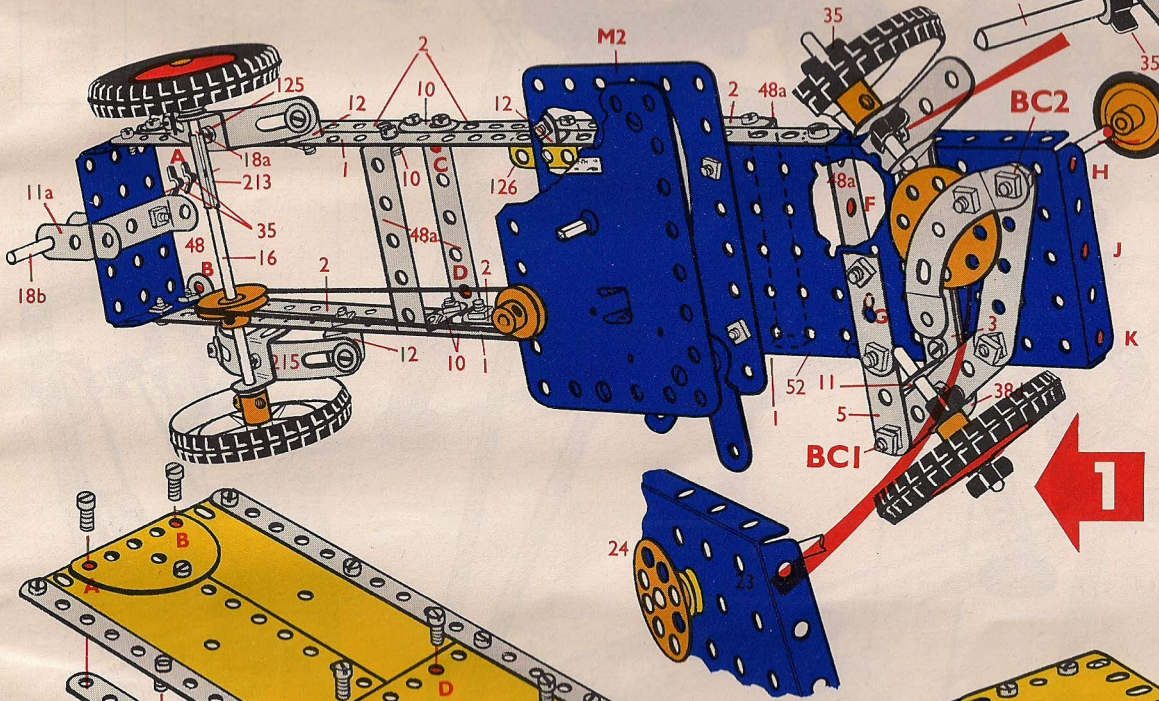
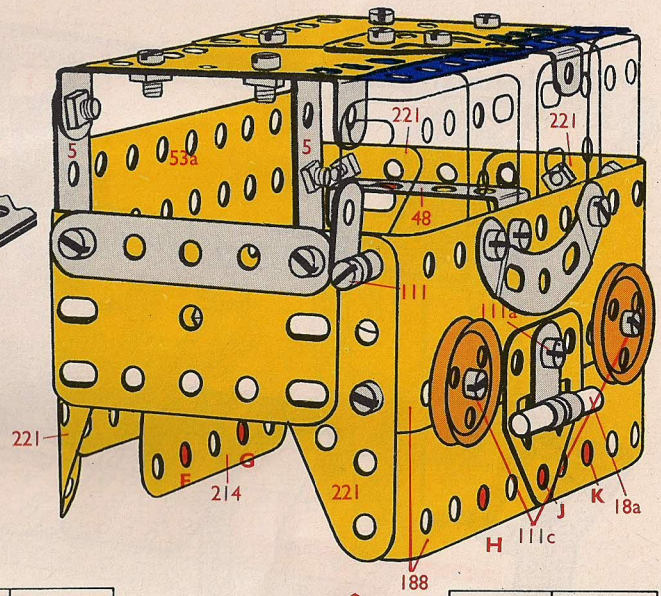

2- 1	53- 37a
4- 2	43- 37b
2- 3	14- 38
5- 5	2- 38d
4-10	1- 48
2-11	4- 48a
1-11a	1- 51
6-12	1- 52
2-16	1- 90a
2-17	4-111c
1-18a	2-125
1-18b	2-126
2-22	1-155
1-23	*1-186b
1-23a	4-187
1-24	1-213
8-35	2-215



4- 5	2-111c
1-12c	2-126a
1-18a	2-188
2-22a	2-189
31-37a	2-190
27-37b	2-193
1-48	1-193a
2-48a	2-194a
1-53a	2-212a
2-90a	1-214
1-111	4-221
1-111a	

2- 1
4- 2
23- 37a
23- 37b
1- 53a
2-190
2-191
2-192
1-214
2-215

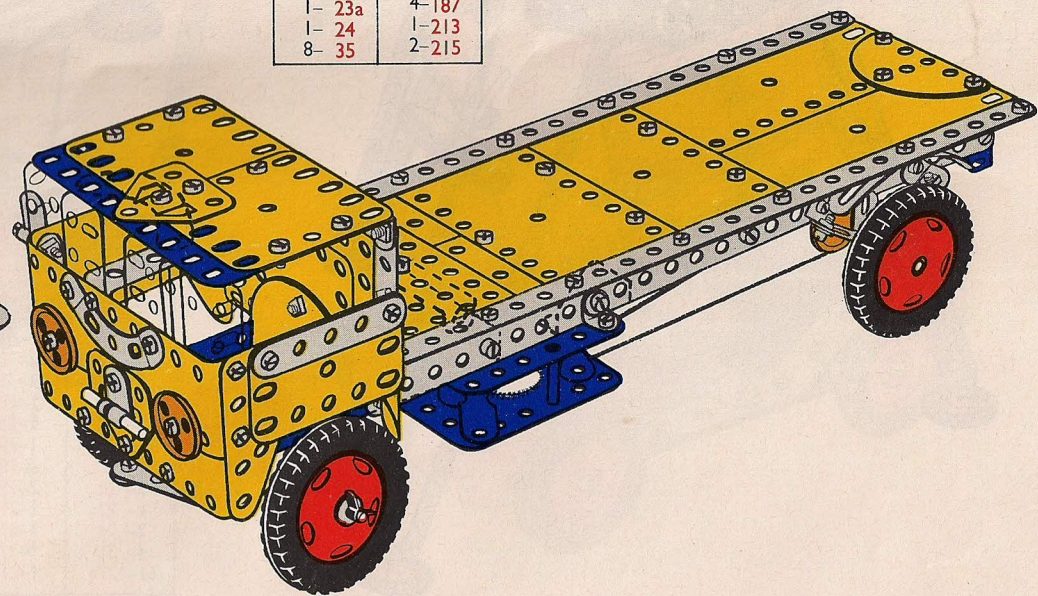

5.4

Véhicule lunaire

4- 1	1- 18a	2- 48	1-176
8- 2	1- 18b	6- 48a	1-186
2- 3	1- 19s	1- 51	3-187
7- 5	1- 20a	1- 52	2-188
4- 10	4- 22	2- 53a	2-192
2- 11	1- 22a	2- 54	1-212
1- 11a	2- 24	2- 90a	1-212a
10- 12	9- 35	1-111a	1-213
4- 12c	105- 37a	6-111c	1-215
1- 15b	83- 37b	1-126	2-221
2- 16	8- 38	3-142c	
2- 17	1- 40	1-155	

1- 2	4- 38
7- 5	1- 40
1- 11a	1- 48
2- 12	2- 90a
1- 16	1-111a
1- 19s	6-111c
1- 20a	1-176
1- 22	1-186
5- 35	2-188
40- 37a	2-221
18- 37b	

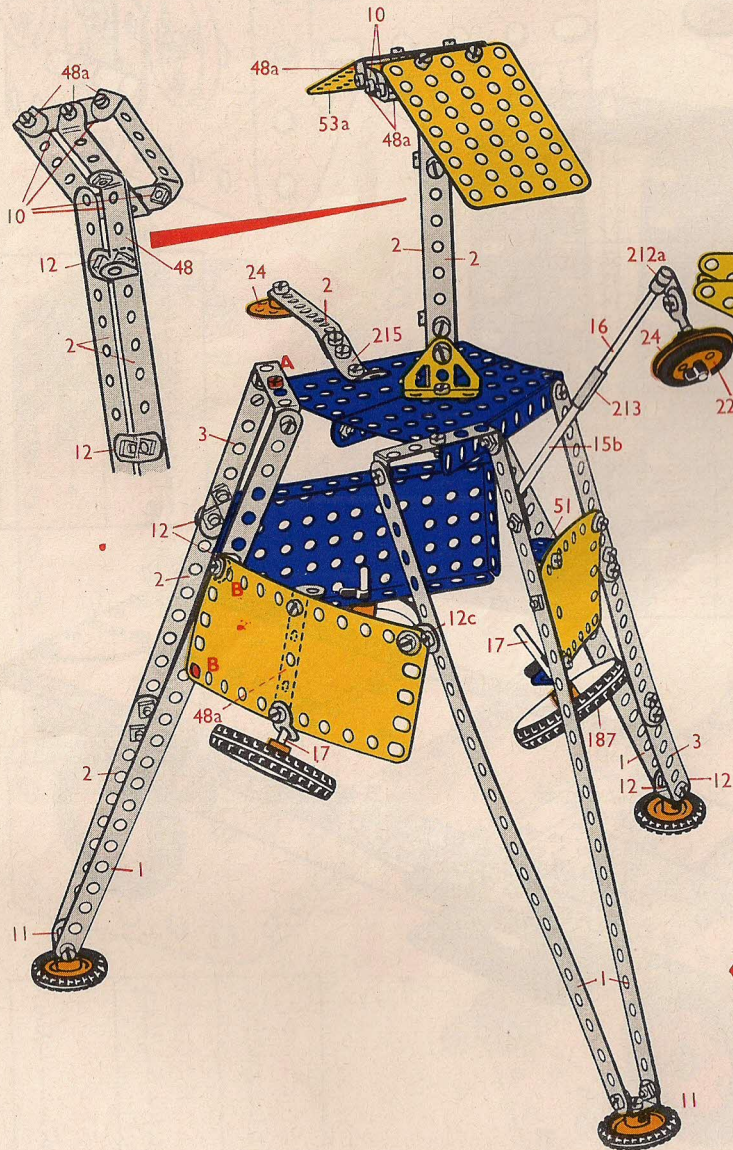

4- 1	65- 37b
7- 2	4- 38
2- 3	1- 48
4- 10	6- 48a
2- 11	1- 51
8- 12	1- 52
4- 12c	2- 53a
1- 15b	2- 54
1- 16	1-126
2- 17	3-142c
1- 18a	1-155
1- 18b	3-187
3- 22	2-192
1- 22a	1-212
2- 24	1-212a
4- 35	1-213
61- 37a	1-215

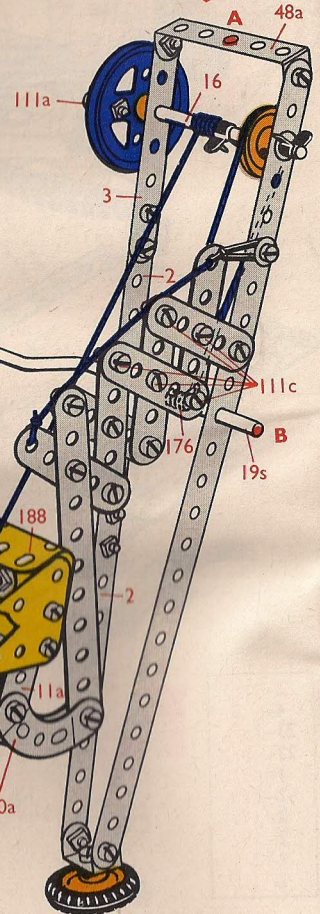

5.5

Pont de garage

4- 1	1- 18b	1- 40	4- 142c
8- 2	1- 19s	1- 48	1- 186
2- 3	1- 20a	6- 48a	2- 188
9- 5	4- 22	1- 52	2- 189
4- 10	2- 22a	2- 53a	2- 191
2- 11	2- 24	2- 54	2- 192
4- 12	7- 35	3- 90a	1- 193
2- 12c	74- 37a	5- 111c	2- 212a
1- 15b	66- 37b	2- 125	2- 221
2- 16	14- 38	2- 126	
1- 17	2- 38d	2- 126a	

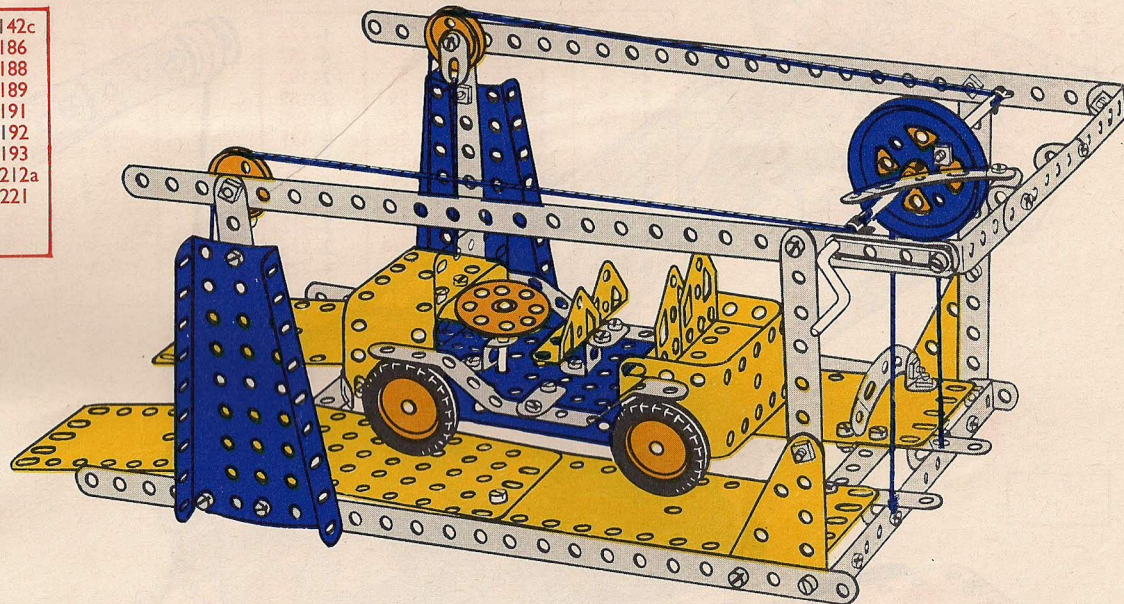

4- 1	1- 20a	6- 48a
6- 2	2- 22a	2- 53a
2- 3	1- 24	2- 54
9- 5	5- 35	3- 90a
2- 10	56- 37a	5- 111c
1- 11	48- 37b	1- 186
2- 12	4- 38	2- 191
1- 15b	2- 38d	2- 192
1- 18b	1- 40	2- 212a
1- 19s	1- 48	2- 221

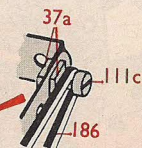
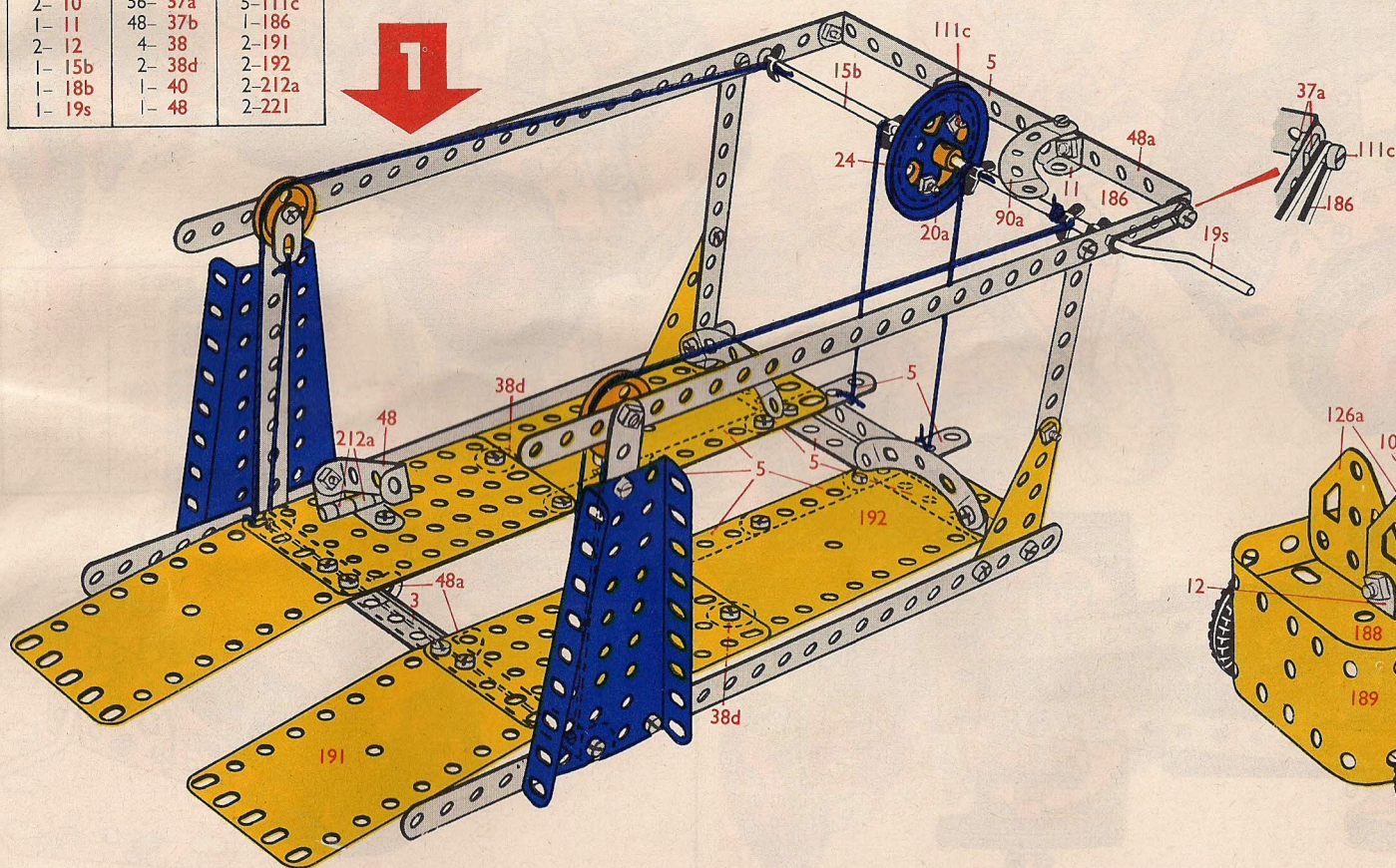

2- 2	4- 22	2- 125
2- 10	1- 24	2- 126
1- 11	2- 35	2- 126a
2- 12	18- 37a	4- 142c
2- 12c	18- 37b	2- 188
2- 16	10- 38	2- 189
1- 17	1- 52	1- 193

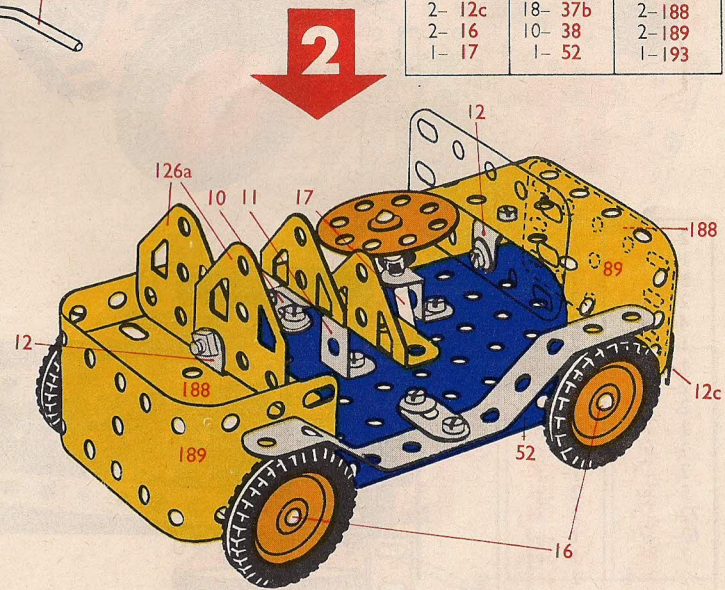

5.6

Grue Jumbo

2- 1	1- 20a	6- 48a	1- 176
8- 2	4- 22	1- 51	4- 187
2- 3	1- 23	1- 52	2- 188
9- 5	1- 23a	2- 54	2- 189
2- 10	2- 24	1- 57c	1- 190
2- 11	2- 27f	2- 90a	2- 191
1- 11a	10- 35	2- 111	2- 194
4- 12	104- 37a	2- 111a	1- 200
2- 15b	88- 37b	1- 111c	1- 212
2- 16	15- 38	2- 126	2- 212a
2- 17	2- 38d	2- 126a	2- 214
2- 18a	1- 40	1- 142c	4- 221
1- 19s	2- 48	2- 155	

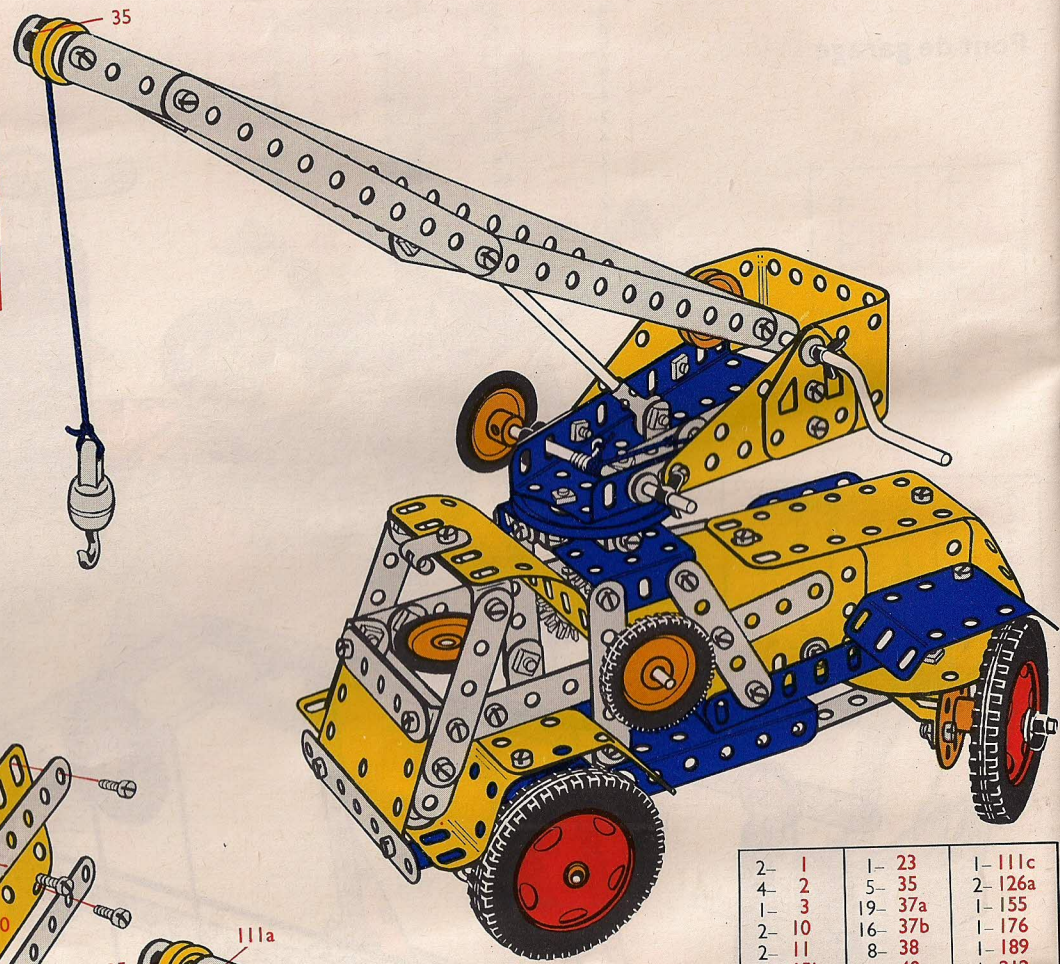

2- 1	1- 23	1- 111c
4- 2	5- 35	2- 126a
1- 3	19- 37a	1- 155
2- 10	16- 37b	1- 176
2- 11	8- 38	1- 189
1- 15b	1- 40	1- 212
1- 16	1- 48	1- 212a
1- 19s	1- 54	2- 221
1- 20a	1- 57c	
2- 22	1- 111a	

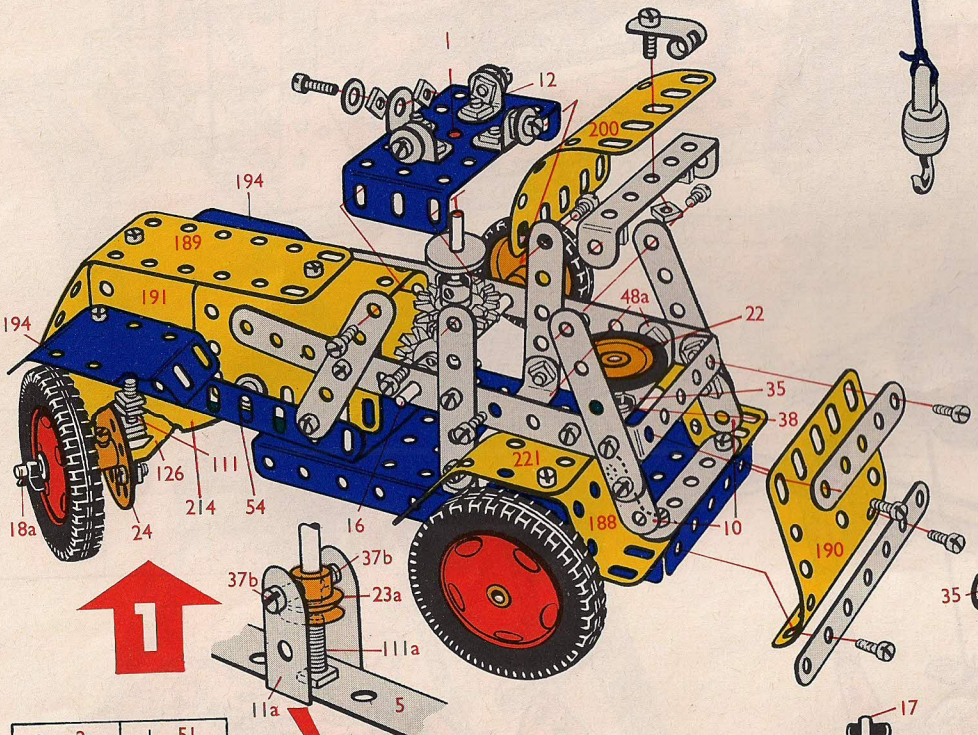

2- 2	1- 51
1- 3	1- 52
8- 5	1- 54
2- 10	2- 90a
4- 12	2- 111
1- 15b	2- 126
1- 16	1- 142c
2- 17	1- 155
2- 18a	4- 187
2- 22	2- 188
2- 24	1- 189
2- 27f	1- 190
5- 35	2- 191
72- 37a	2- 194
62- 37b	1- 200
7- 38	1- 212a
2- 38d	2- 214
1- 48	2- 221
4- 48a	

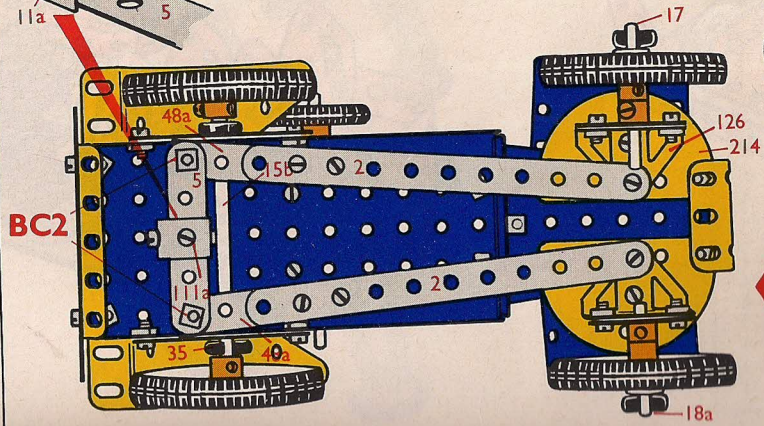

2- 2
1- 5
1- 11a
1- 23a
13- 37a
10- 37b
2- 48a
1- 111a

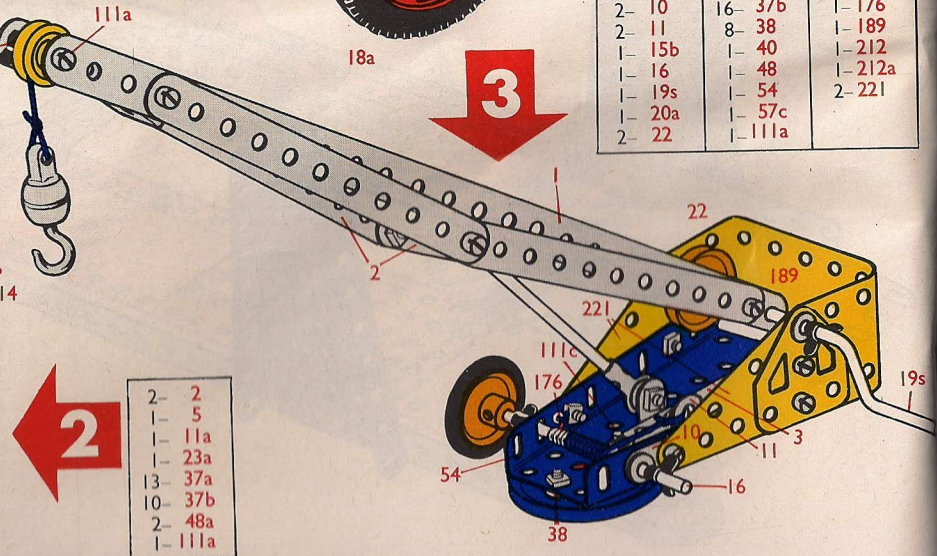

5.7

Pelle mécanique

8- 2	1- 19s	1- 52	3-190
2- 3	4- 22	2- 53a	2-191
9- 5	2- 24	2- 54	1-199
1- 10	2- 27f	4- 90a	1-200
2- 11	16- 35	4-111c	1-212
1- 11a	95- 37a	2-125	2-212a
10-12	93- 37b	2-126	1-213
4- 12c	12- 38	2-126a	2-214
2- 15b	2- 38d	1-155	4-221
4- 16	1- 40	1-176	
2- 17	1- 48	1-186	
2- 18a	6- 48a	4-187	
1- 18b	1- 51	1-188	

2- 2	2- 22	1- 51	1-188
2- 3	1- 24	1- 52	3-190
2- 5	2- 27f	2- 54	2-191
1- 11a	3- 35	2- 90a	1-200
4- 12c	55- 37a	2-111c	1-212
2- 16	53- 37b	2-126	2-212a
1- 18a	4- 38	2-126a	2-214
1- 18b	2- 38d	1-155	
1- 19s	4- 48a	1-176	

5- 5	9- 37b
2- 11	4- 38
2- 16	1- 48a
2- 17	1-111c
1- 24	4-187
7- 35	1-199
10- 37a	1-213

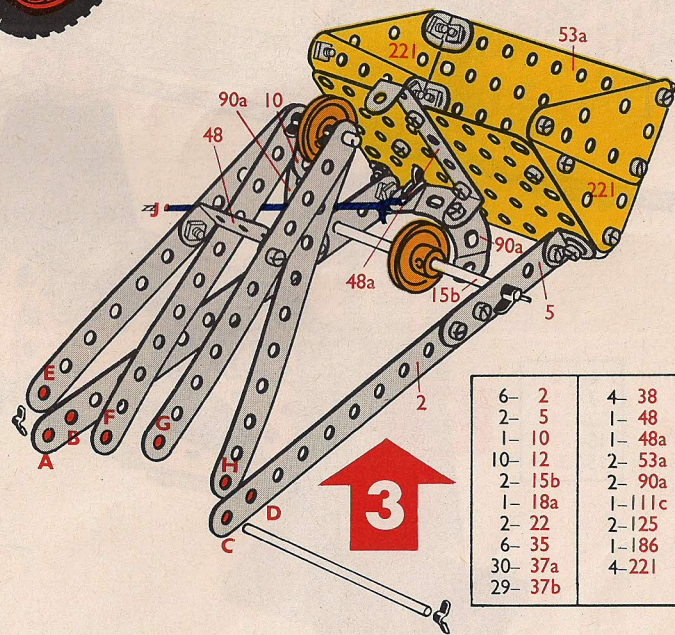
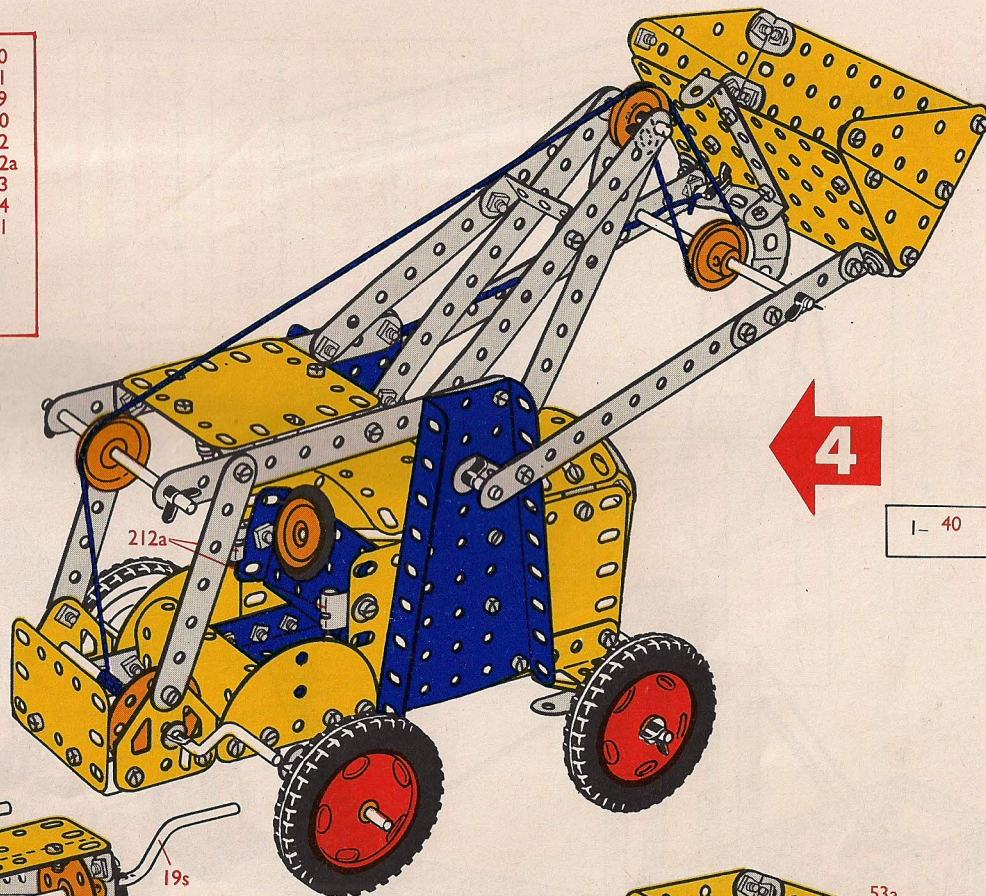
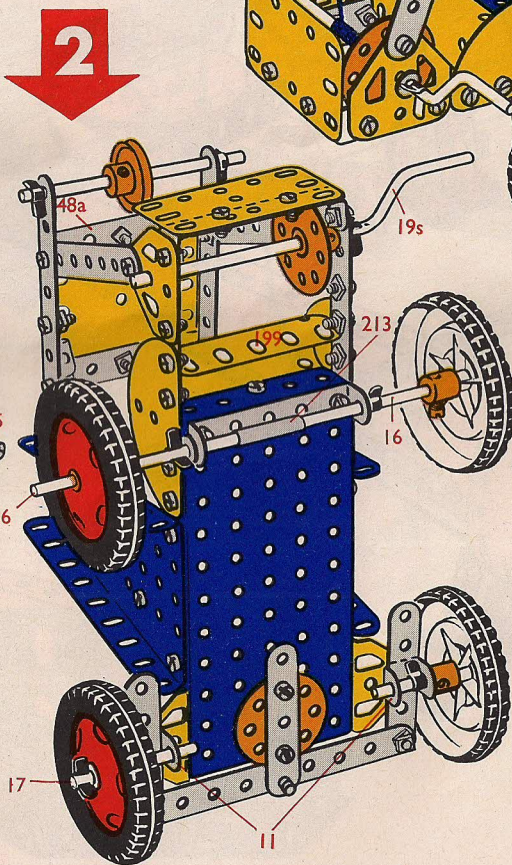
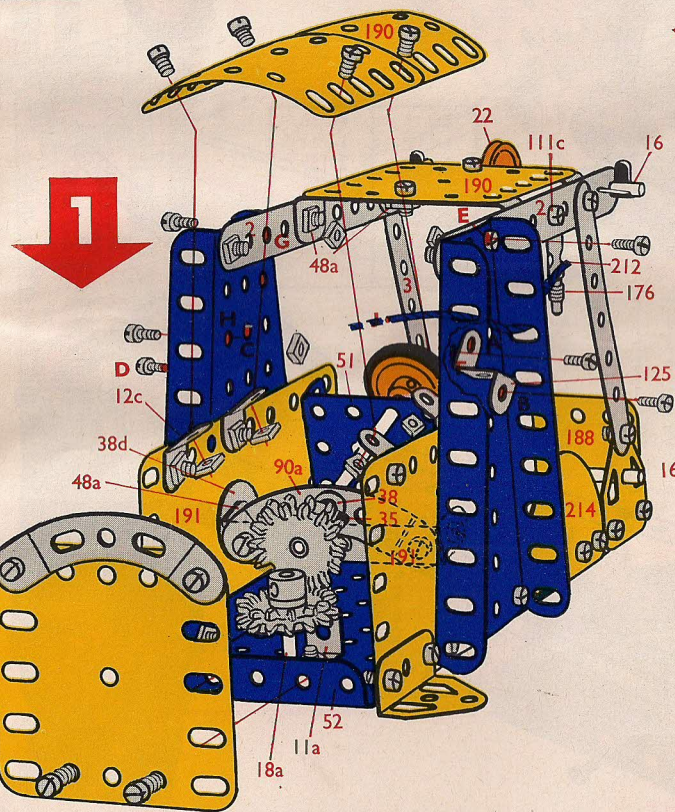

6- 2	4- 38
2- 5	1- 48
1- 10	1- 48a
10- 12	2- 53a
2- 15b	2- 90a
1- 18a	1-111c
2- 22	2-125
6- 35	1-186
30- 37a	4-221
29- 37b	

1- 40

5.8

Hélicoptère

4- 1	4- 22	1- 51	1-191
8- 2	2- 22a	2- 54	2-192
2- 3	1- 23	3- 90a	2-193
9- 5	2- 24	2-111	1-193a
1-10	2- 27f	2-125	1-199
1-11a	1- 35	2-126	1-200
5-12	94- 37a	2-126a	1-213
4-12c	91- 37b	2-142c	2-214
2-15b	14- 38	2-155	4-215
1-16	1- 38d	1-186	4-221
1-18a	1- 40	2-188	
2-19b	1- 48	2-189	
1-20a	4- 48a	3-190	

1- 1	1- 20a	1- 48	1-186
1- 2	3- 22	4- 48a	2-188
2- 3	2- 22a	1- 51	3-190
4- 5	1- 23	2- 54	2-193
1-11a	2- 27f	3- 90a	1-193a
3-12	1- 35	1-111	1-200
4-12c	54- 37a	2-125	1-213
2-15b	52- 37b	2-126	2-214
1-16	7- 38	2-126a	3-215
1-18a	1- 38d	2-142c	4-221
2-19b	1- 40	2-155	

3- 1	4- 38
1- 2	1-111
2- 5	2-189
1-10	1-191
2-12	2-192
1-22	1-199
25- 37a	1-215
24- 37b	

6- 2
3- 5
2- 24
15- 37a
15- 37b

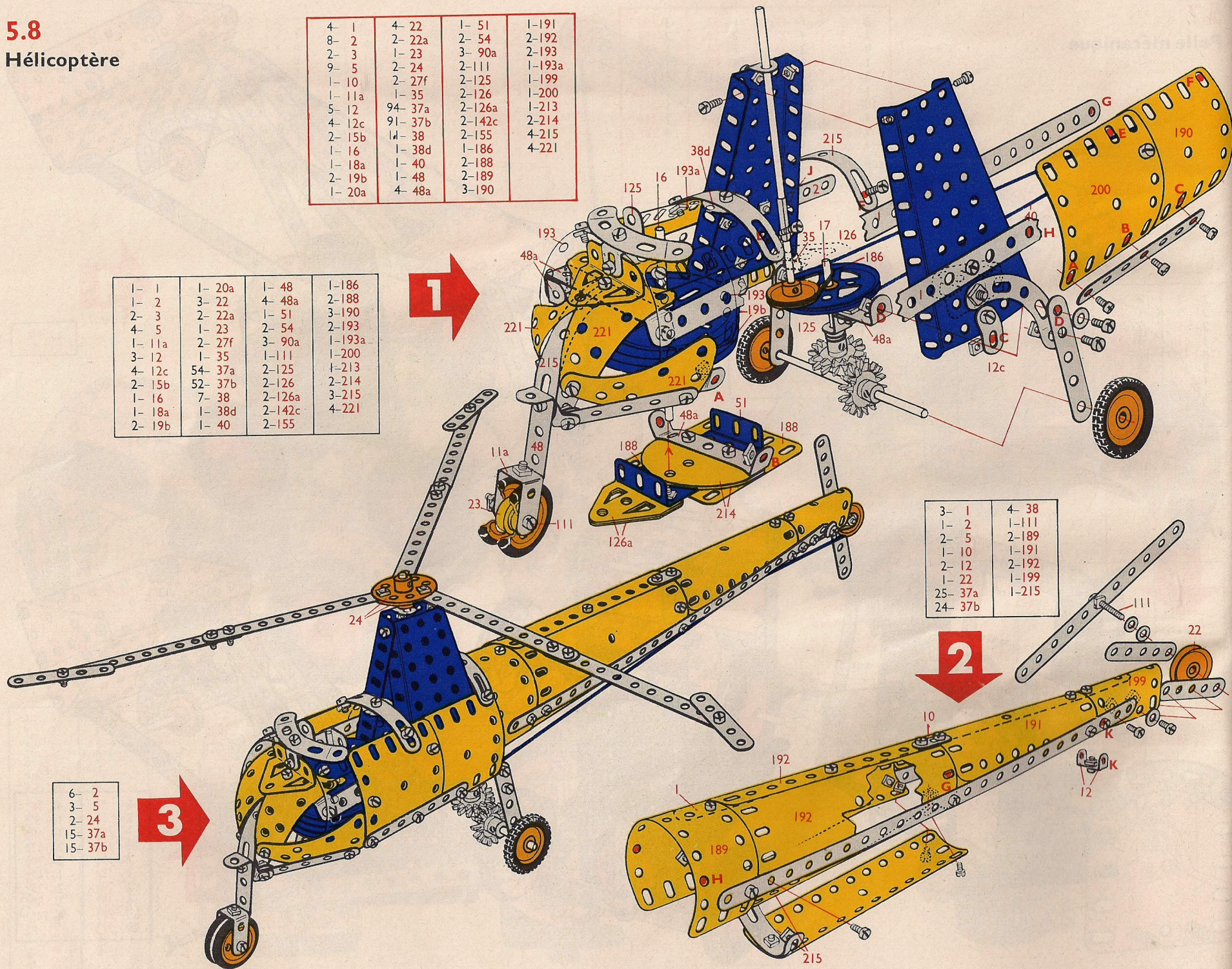

5.9

Grue à benne preneuse

4- 1	1- 19s	2- 38d	2- 126a
8- 2	1- 20a	1- 40	1- 176
2- 3	4- 22	2- 48	1- 186a
9- 5	2- 22a	6- 48a	*1- 186b
4- 10	1- 23	1- 51	2- 187
2- 11	*1- 23a	1- 52	2- 188
1- 11a	1- 23a	2- 53a	2- 189
10- 12	2- 24	2- 54	1- 190
1- 12c	2- 27f	4- 90a	1- 200
2- 15b	16- 35	2- 111	2- 212a
4- 16	103- 37a	2- 111a	1- 213
2- 17	93- 37b	2- 111c	2- 221
2- 19b	14- 38	2- 126	*1- M5

*Non inclus dans la boîte



6- 2
2- 5
2- 10
4- 12
1- 12c
2- 17
2- 22
1- 23
2- 35
25- 37a
23- 37b
1- 48
1- 48a
3- 90a
2- 111c
2- 126
1- 190
1- 200
2- 212a

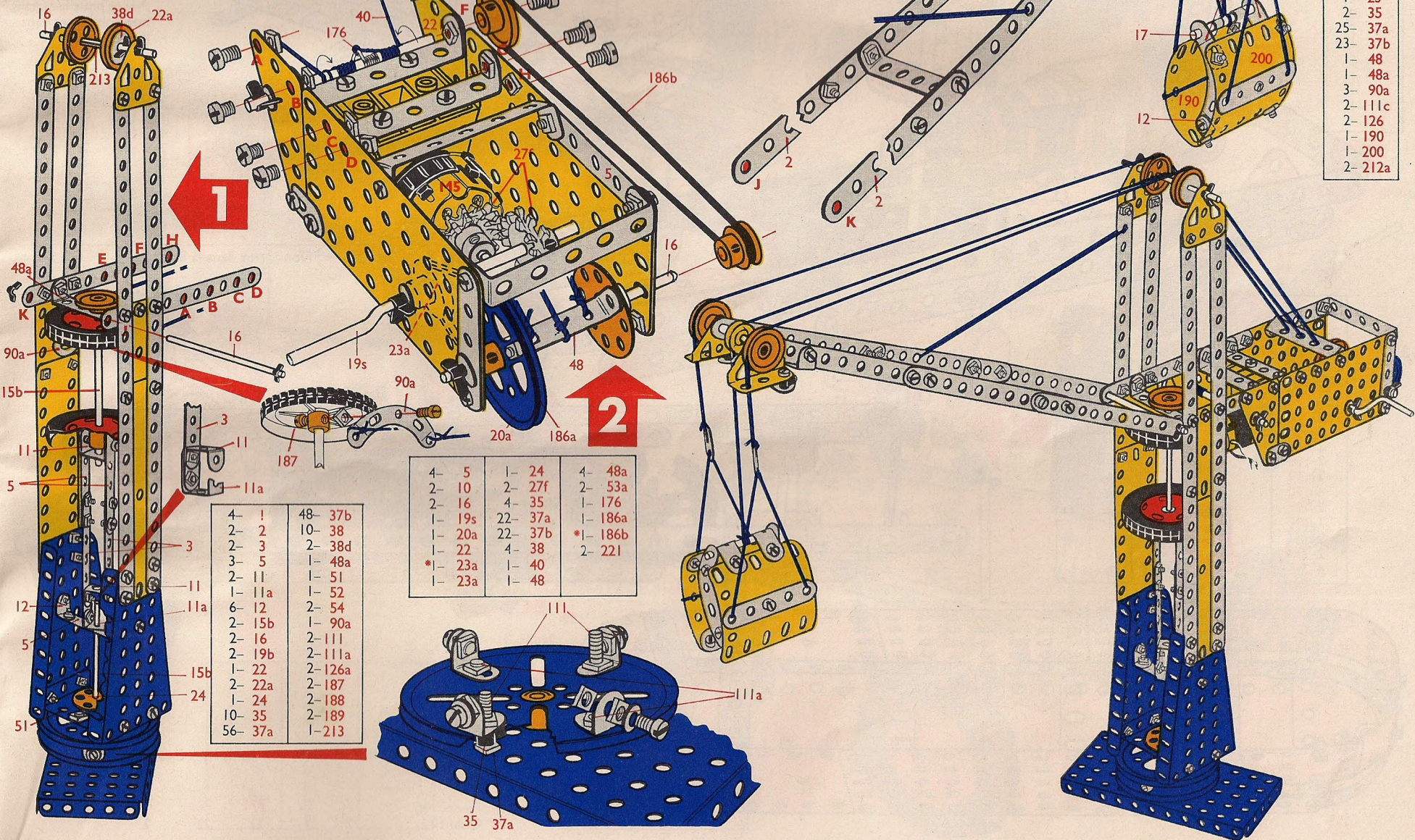

4- 1	48- 37b
2- 2	10- 38
2- 3	2- 38d
3- 5	1- 48a
2- 11	1- 51
1- 11a	1- 52
6- 12	2- 54
2- 15b	1- 90a
2- 16	2- 111
2- 19b	2- 111a
1- 22	2- 126a
2- 22a	2- 187
1- 24	2- 188
10- 35	2- 189
56- 37a	1- 213

4- 5	1- 24	4- 48a
2- 10	2- 27f	2- 53a
2- 16	4- 35	1- 176
1- 19s	22- 37a	1- 186a
1- 20a	22- 37b	*1- 186b
1- 22	4- 38	2- 221
*1- 23a	1- 40	
1- 23a	1- 48	

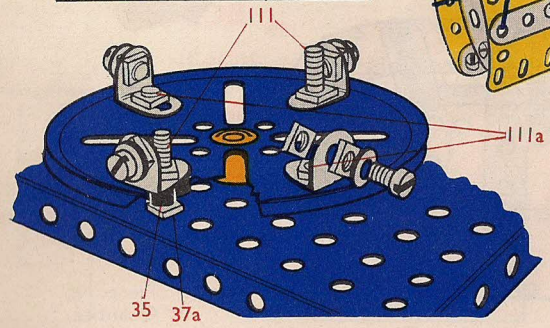

5.10

Loco diesel-électrique

2- 1	32- 37b
2- 2	1- 38
4- 5	2- 38d
4- 10	2- 48a
1- 11a	1- 51
1- 12	1- 52
1- 16	3- 111c
*1- 23a	2- 126
1- 24	2- 126a
2- 35	1- 212
40- 37a	

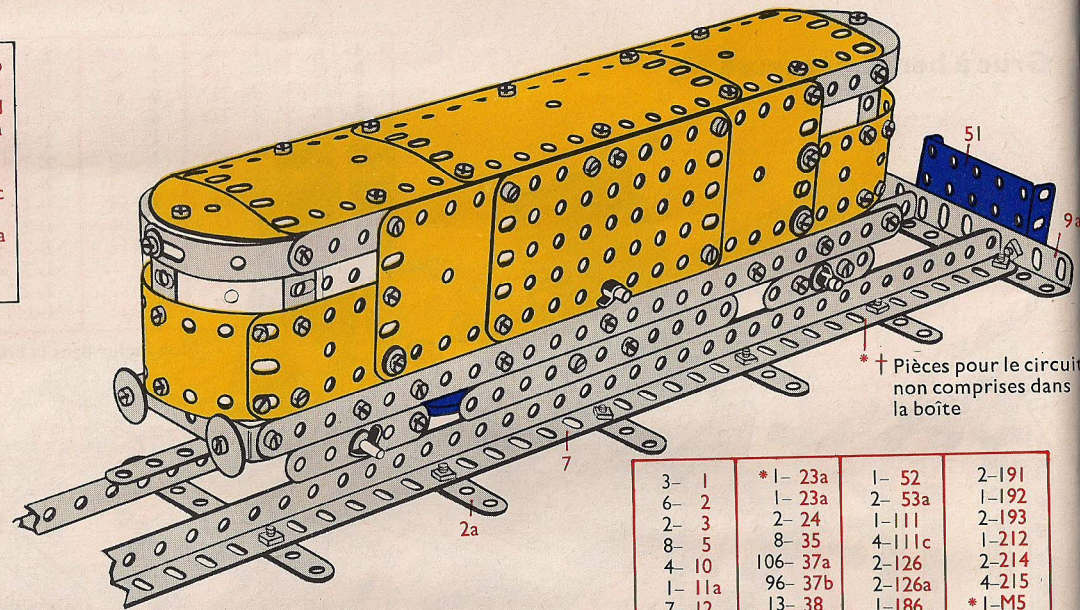

† Pièces pour le circuit non comprises dans la boîte

3- 1	*1- 23a	1- 52	2- 191
6- 2	1- 23a	2- 53a	1- 192
2- 3	2- 24	1- 111	2- 193
8- 5	8- 35	4- 111c	1- 212
4- 10	106- 37a	2- 126	2- 214
1- 11a	96- 37b	2- 126a	4- 215
7- 12	13- 38	1- 186	*1- M5
4- 16	2- 38d	2- 188	
1- 20a	6- 48a	2- 189	
4- 22	1- 51	4- 190	

**Non inclus dans la boîte

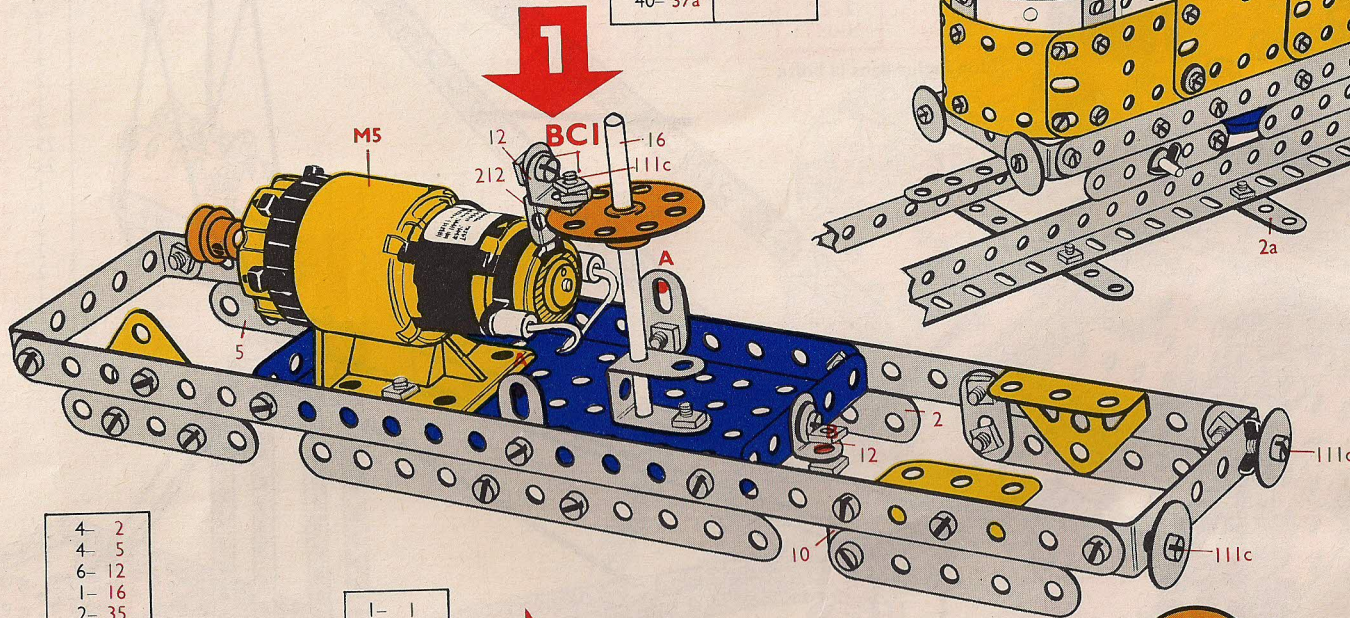

4- 2
4- 5
6- 12
1- 16
2- 35
60- 37a
60- 37b
8- 38
4- 48a
2- 53a
2- 188
2- 189
4- 190
2- 191
1- 192
2- 193
2- 214
4- 215

1- 1
2- 3
2- 16
1- 20a
4- 22
1- 23a
1- 24
4- 35
6- 37a
3- 37b
4- 38
1- 111
1- 111c
1- 186

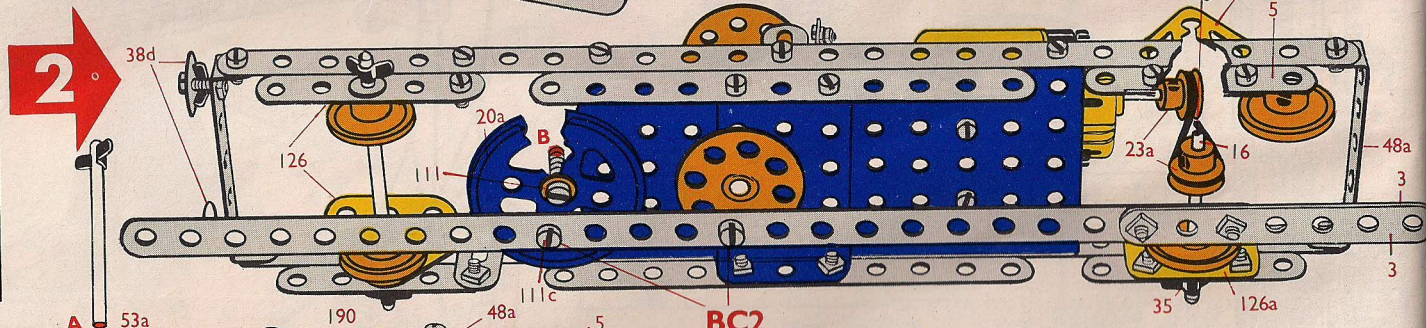

Pièces pour circuit de 62cm non comprises dans la boîte

Pièces No	2a	7	9a	37a	37b	51
† Quantité	2	2	2	22	22	2

5.11

Tracteur à vapeur

8- 2	4- 22	2- 48	*1-186a
2- 3	2- 22a	6- 48a	1-186a
8- 5	1- 23	1- 52	2-187
2-11	*1- 23a	2- 53a	2-188
1-11a	1- 23a	1-111	3-190
10-12	2- 24	2-111c	2-191
4-12c	2- 27f	2-125	2-192
2-15b	7- 35	2-126	1-194a
4-16	97- 37a	2-126a	1-199
2-17	85- 37b	1-142c	1-212
1-18a	10- 38	1-155	*1-M4
2-19b	2- 38d	1-176	
1-20a	1- 40	1-186	

* Non inclus dans la boîte

2- 5
2- 12c
1- 15b
2- 17
1- 18a
1- 20a
2- 22
*1- 23a
2- 24
3- 35
13- 37a
9- 37b
2- 48a
1-111c
2-126
1-186
*1-186a
1-186a
1-212

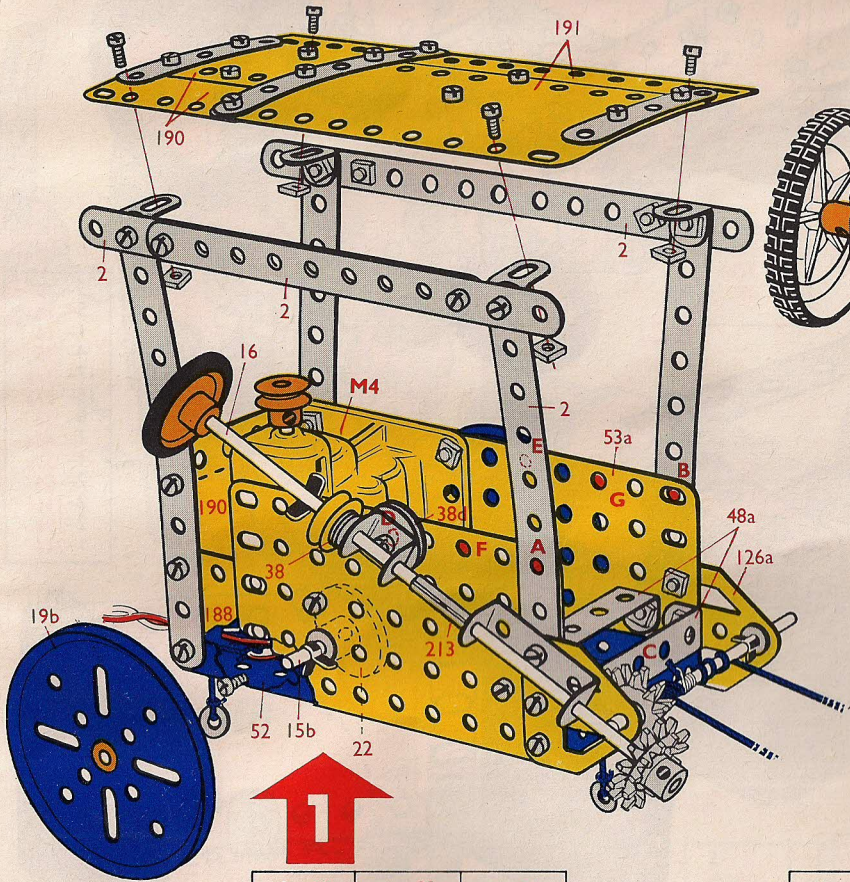

8- 2	1- 23a	1- 52
1- 3	2- 27f	2- 53a
3- 5	4- 35	2-126a
1-11	52- 37a	1-155
6-12	52- 37b	1-176
1-15b	10- 38	2-188
3-16	2- 38d	3-190
2-19b	1- 40	2-191
2-22	1- 48	
1-23	2- 48a	

1- 3	1- 48
3- 5	1- 48a
1-11	1-111
1-11a	1-111c
4-12	2-125
2-12c	1-142c
1-16	2-187
2-22a	2-192
32-37a	1-194a
24-37b	1-199

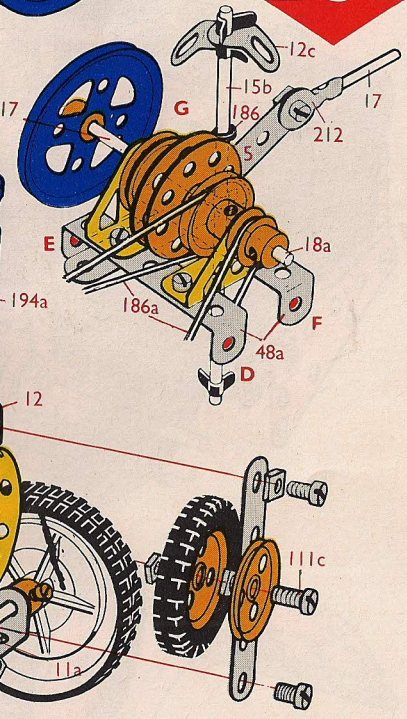
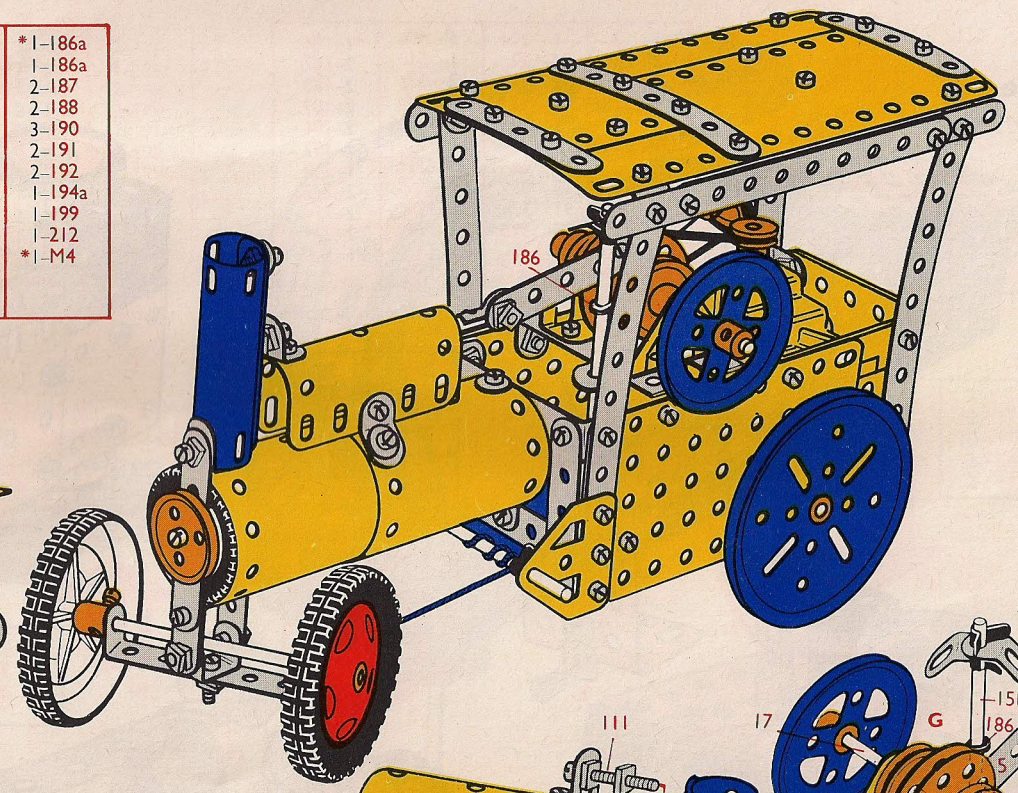

5.12

Chargeuse

2- 2	1- 20a	6- 48a	*1-186b
2- 3	4- 22	1- 51	2-187
9- 5	2- 22a	2- 53a	2-188
4- 10	1- 23	2- 54	2-189
2- 11	*1- 23a	4- 90a	2-191
1- 11a	1- 23a	2-111	1-192
10- 12	2- 24	5-111c	1-212
2- 15b	15- 35	2-125	2-212a
4- 16	91- 37a	2-126	2-214
1- 17	79- 37b	2-126a	2-221
1- 18a	14- 38	2-142c	*1-M4
1- 18b	2- 48	1-155	

*Non inclus dans la boîte

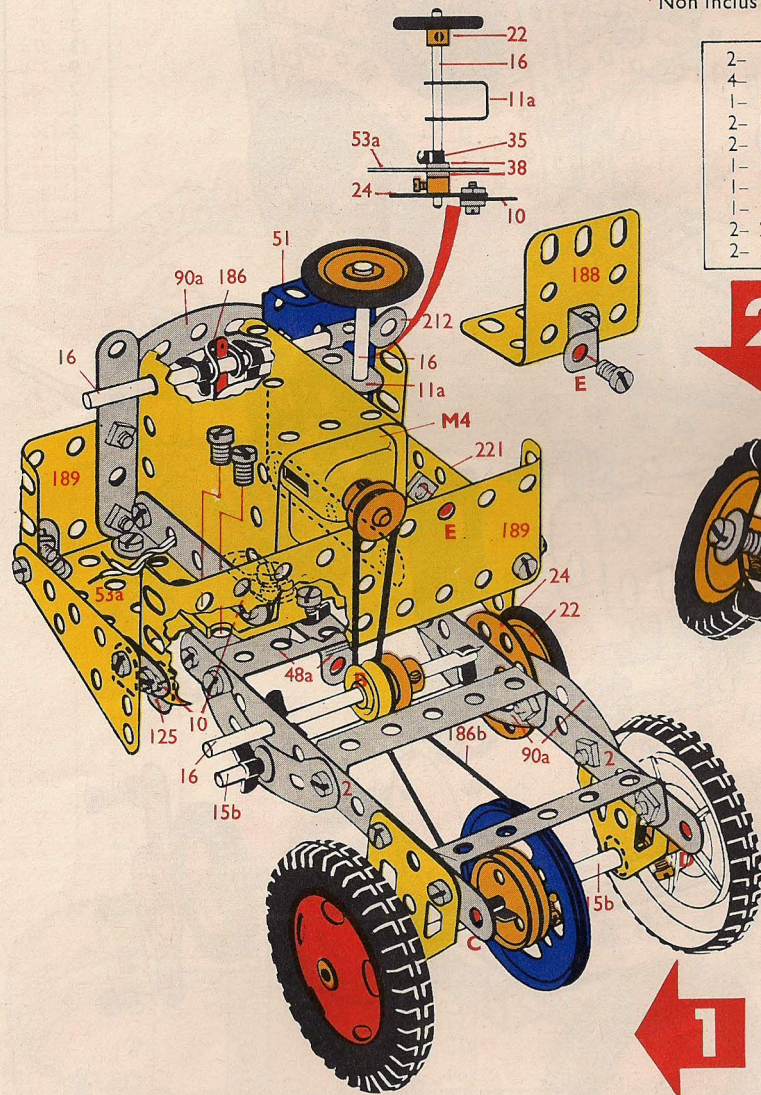

2- 3	25- 37a
4- 5	17- 37b
1- 10	2- 38
2- 11	1- 48
2- 12	2-111
1- 17	2-126
1- 18a	2-142c
1- 18b	2-212a
2- 22	1-214
2- 35	

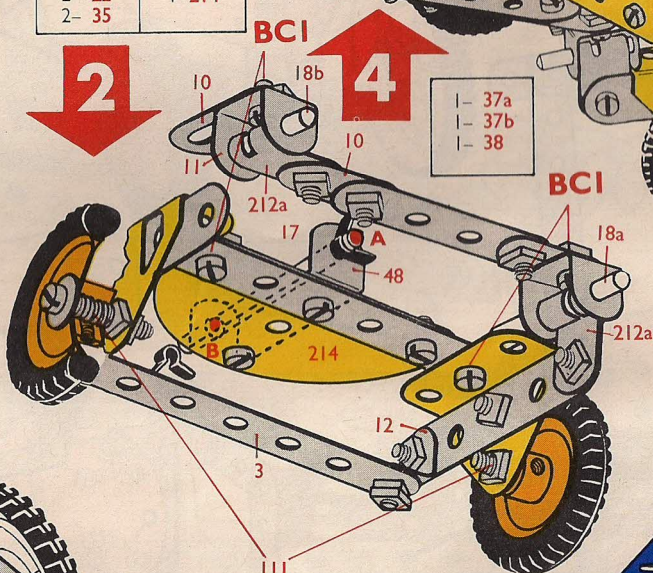

2- 2	1- 23a	2-125
3- 5	2- 24	2-126a
3- 10	9- 35	1-155
1- 11a	48- 37a	*1-186b
3- 12	46- 37b	2-187
2- 15b	6- 38	2-188
3- 16	1- 48	2-189
1- 20a	5- 48a	1-192
2- 22	1- 51	1-212
2- 22a	1- 53a	2-221
1- 23	4- 90a	
*1- 23a	3-111c	

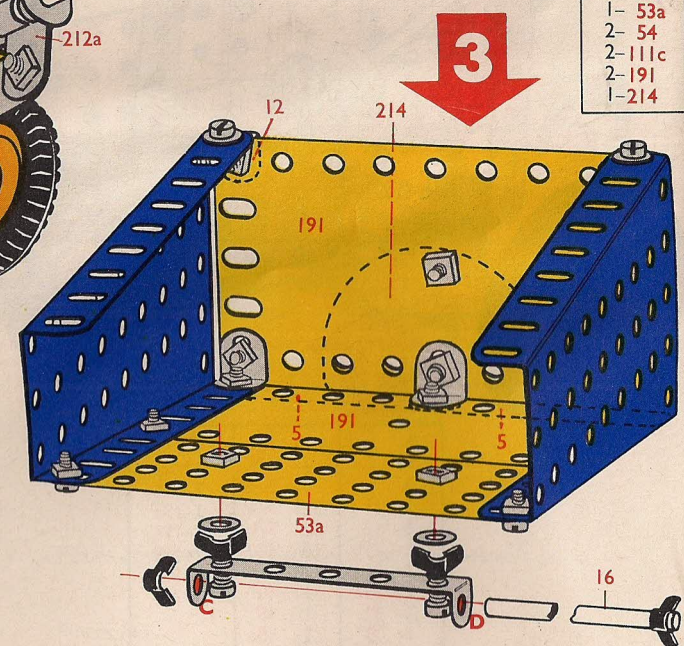
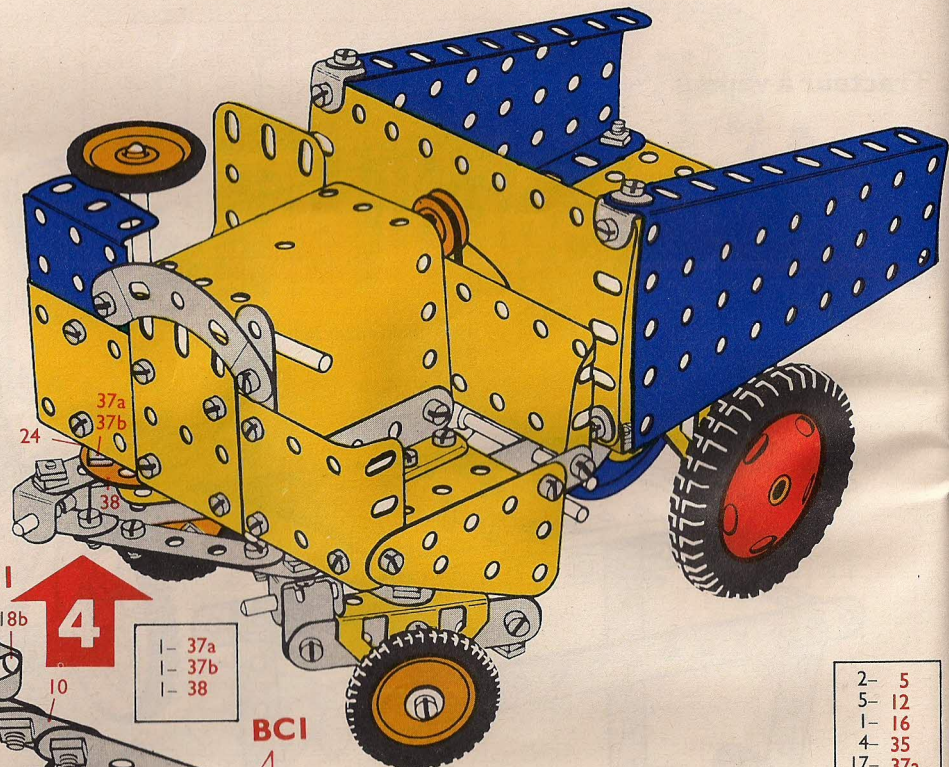

2- 5
5- 12
1- 16
4- 35
17- 37a
15- 37b
6- 38
1- 48a
1- 53a
2- 54
2-111c
2-191
1-214

5.13

Mixer

7- 2	4- 22	3- 48a	2-126a
2- 3	1- 23	1- 51	*1-186b
8- 5	*1- 23a	1- 52	2-188
4-10	1- 23a	2- 53a	2-189
2-11	2- 24	2- 54	1-191
8-12	2- 27f	4- 90a	2-192
2-15b	2- 35	2-111	1-199
1-17	87- 37a	1-111a	1-213
1-18a	80- 37b	2-111c	2-214
1-18b	13- 38	1-125	3-215
1-20a	2- 48	2-126	*1-M5

* Non inclus dans la boîte

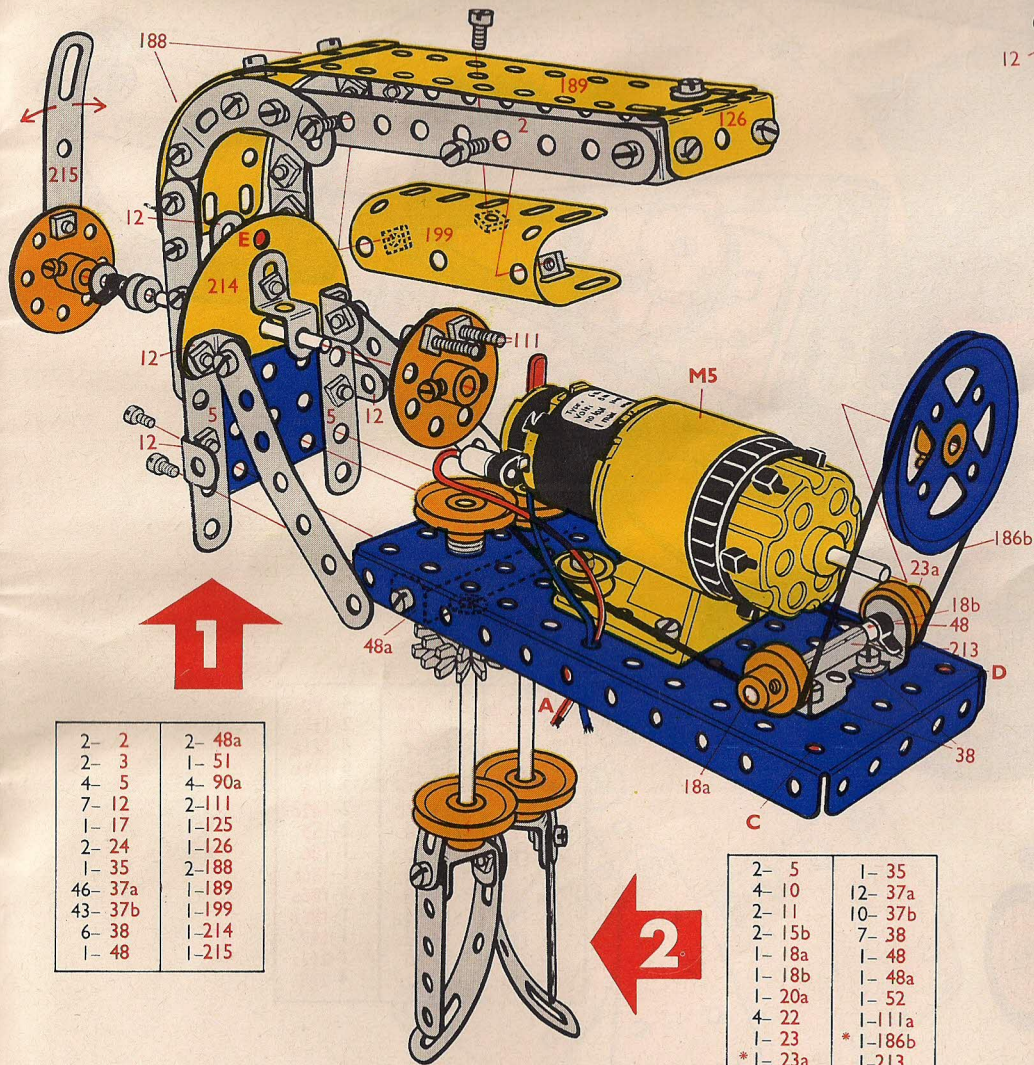

2- 2	2- 48a
2- 3	1- 51
4- 5	4- 90a
7-12	2-111
1-17	1-125
2-24	1-126
1-35	2-188
46-37a	1-189
43-37b	1-199
6-38	1-214
1-48	1-215

2- 5	1- 35
4-10	12- 37a
2-11	10- 37b
2-15b	7- 38
1-18a	1- 48
1-18b	1- 48a
1-20a	1- 52
4-22	1-111a
1-23	*1-186b
*1-23a	1-213
1-23a	2-215
2-27f	

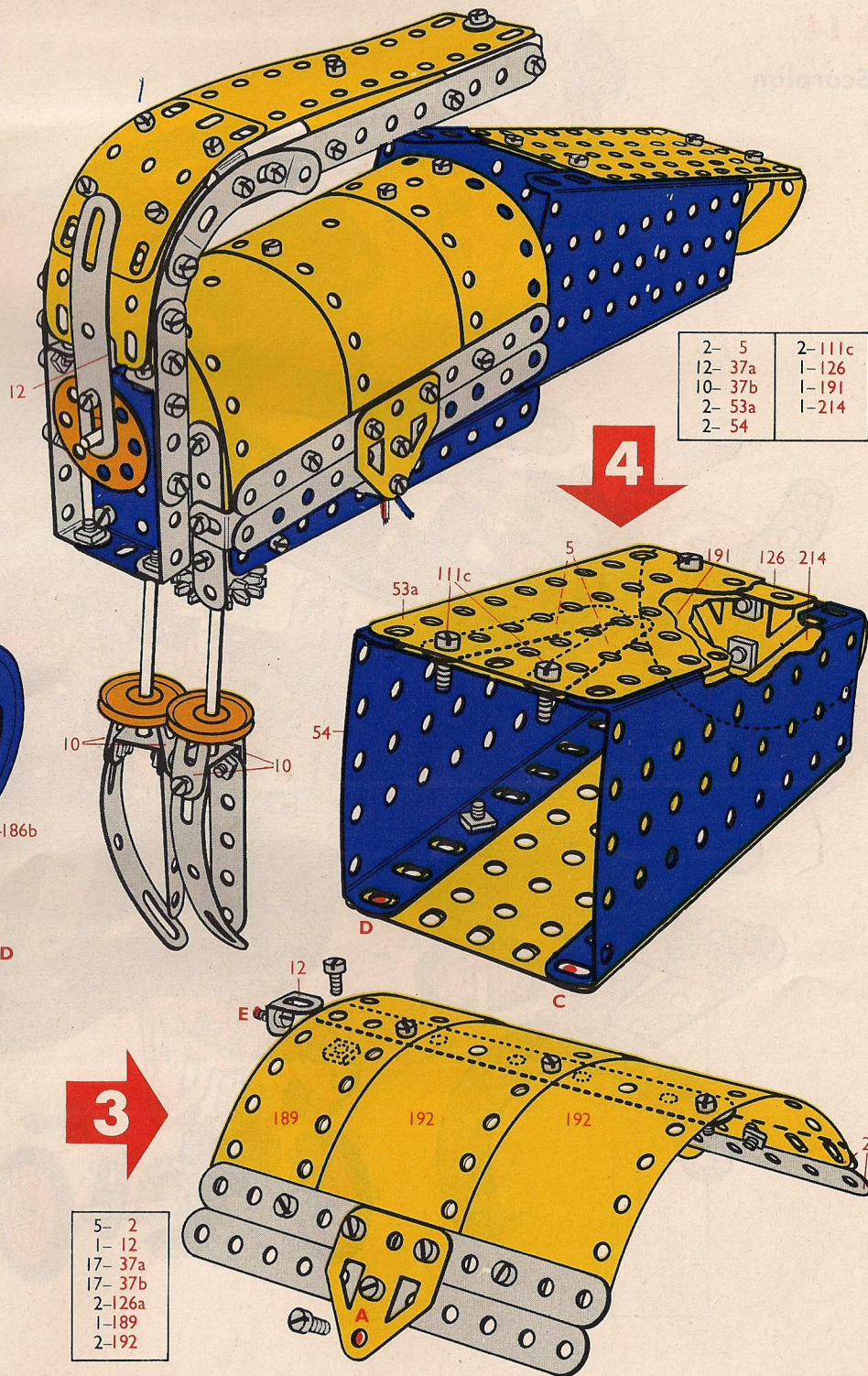

2- 5	2-111c
12- 37a	1-126
10- 37b	1-191
2- 53a	1-214
2- 54	

5- 2	
1-12	
17-37a	
17-37b	
2-126a	
1-189	
2-192	

5.14

Scorpion

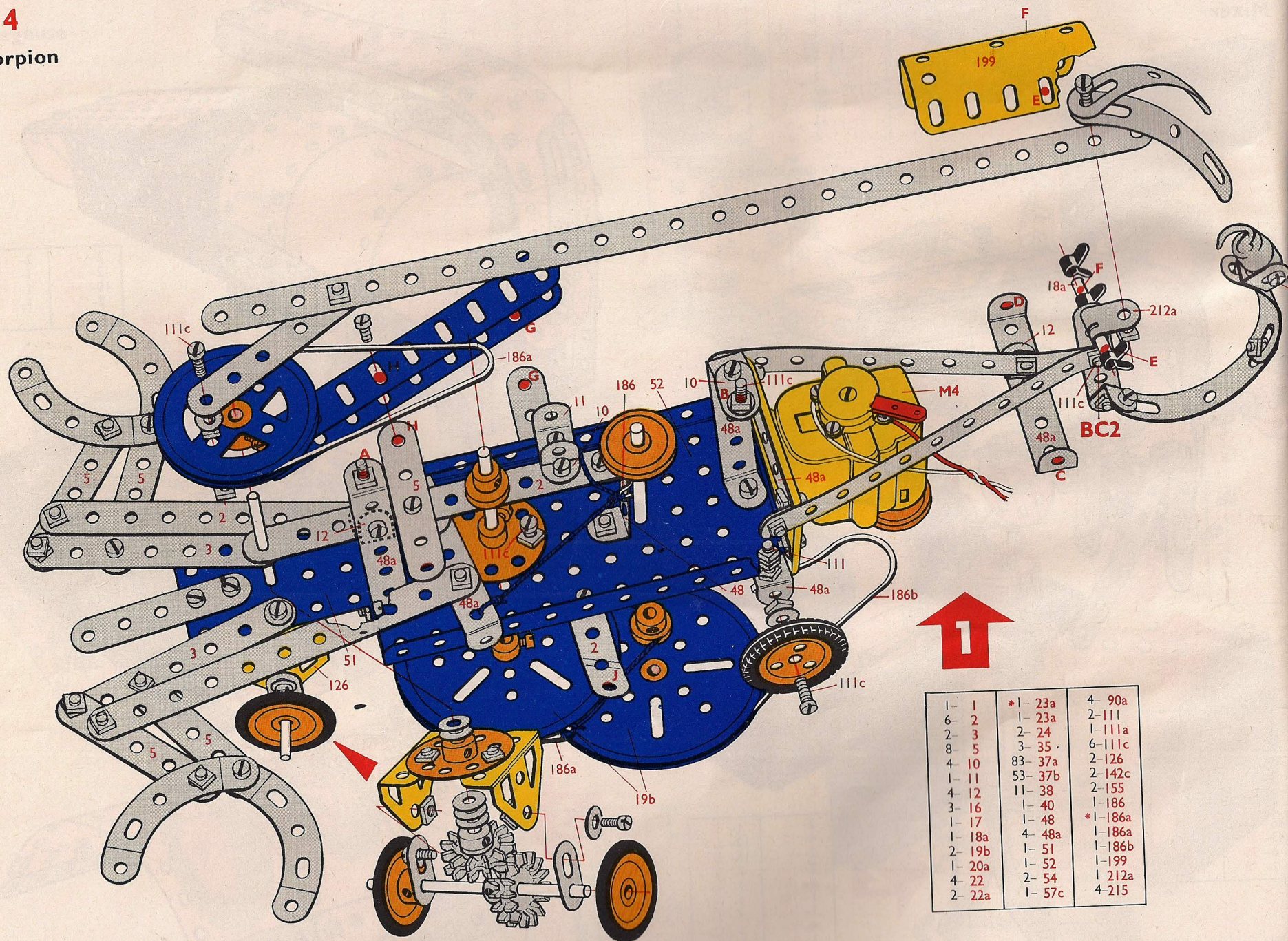

1- 1	2- 22a	1- 57c	2- 191
8- 2	*1- 23a	4- 90a	2- 192
2- 3	1- 23a	2- 111	1- 193
8- 5	2- 24	1- 111a	2- 194
4- 10	3- 35	6- 111c	1- 199
1- 11	107- 37a	2- 126	1- 200
4- 12	75- 37b	2- 142c	1- 212a
3- 12c	13- 38	2- 155	2- 214
3- 16	1- 40	1- 186	4- 215
1- 17	1- 48	*1- 186a	4- 221
1- 18a	4- 48a	1- 186a	*1- M4
2- 19b	1- 51	1- 186b	
1- 20a	1- 52	1- 189	
4- 22	2- 54	4- 190	

*Non inclus dans la boîte

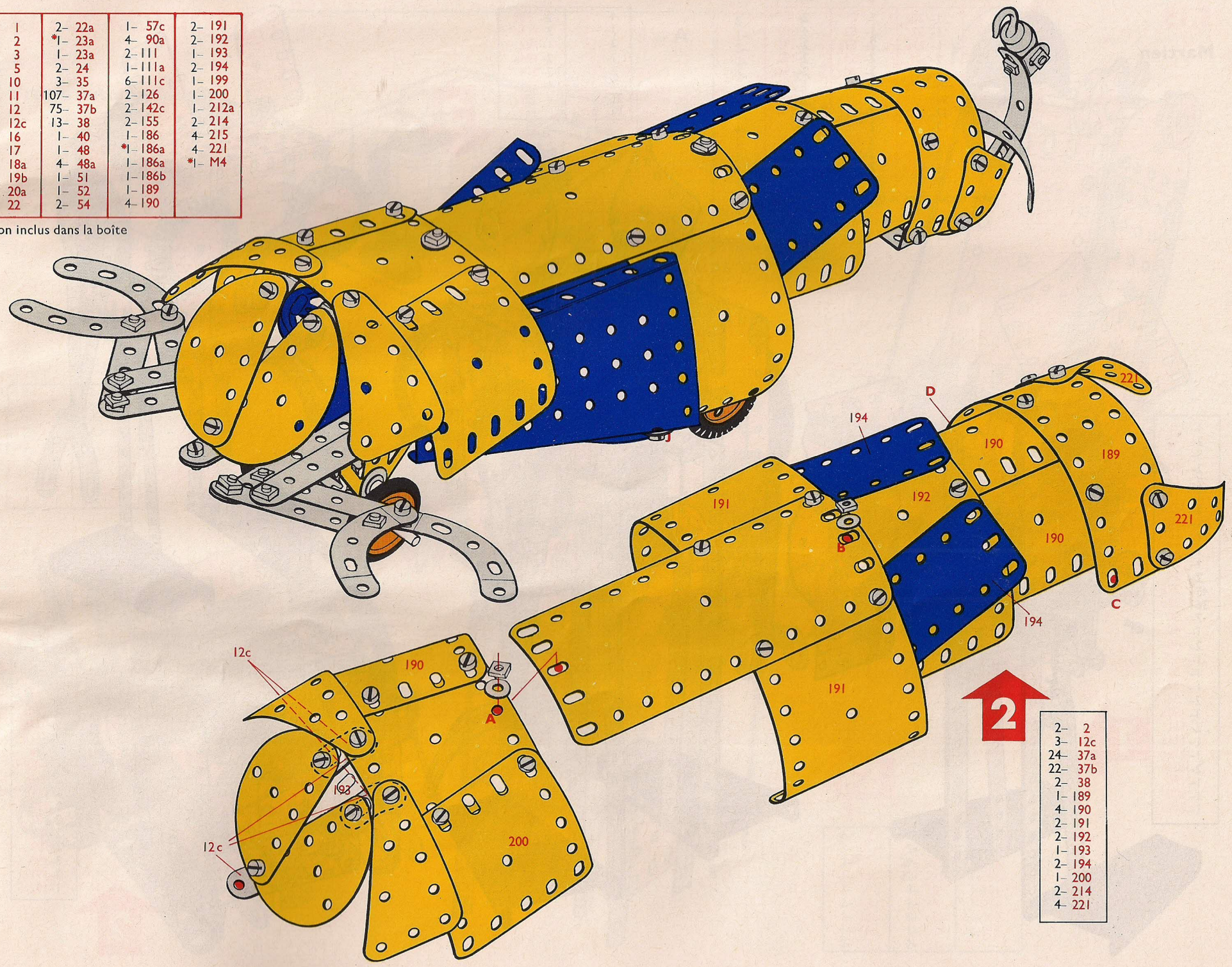

2

2- 2
3- 12c
24- 37a
22- 37b
2- 38
1- 189
4- 190
2- 191
2- 192
1- 193
2- 194
1- 200
2- 214
4- 221

5.15

Martien

4- 1	1- 20a	1- 51	2-189
8- 2	1- 22	1- 52	4-190
2- 3	1- 23a	2- 53a	2-191
9- 5	2- 24	2- 54	2-192
2- 10	2- 35	3- 90a	2-194a
2- 11	105- 37a	2-111	1-200
1- 11a	94- 37b	1-111a	1-212a
10- 12	17- 38	4-111c	2-214
2- 17	2- 38d	2-126	4-215
1- 18a	1- 40	2-126a	4-221
1- 18b	2- 48	2-187	*1-M5
2- 19b	6- 48a	2-188	

4- 2	2- 38d
1- 3	2-111c
2- 12	1-192
2- 17	2-194a
2- 19b	2-214
2- 35	4-215
21- 37a	4-221
19- 37b	

* Non inclus dans la boîte

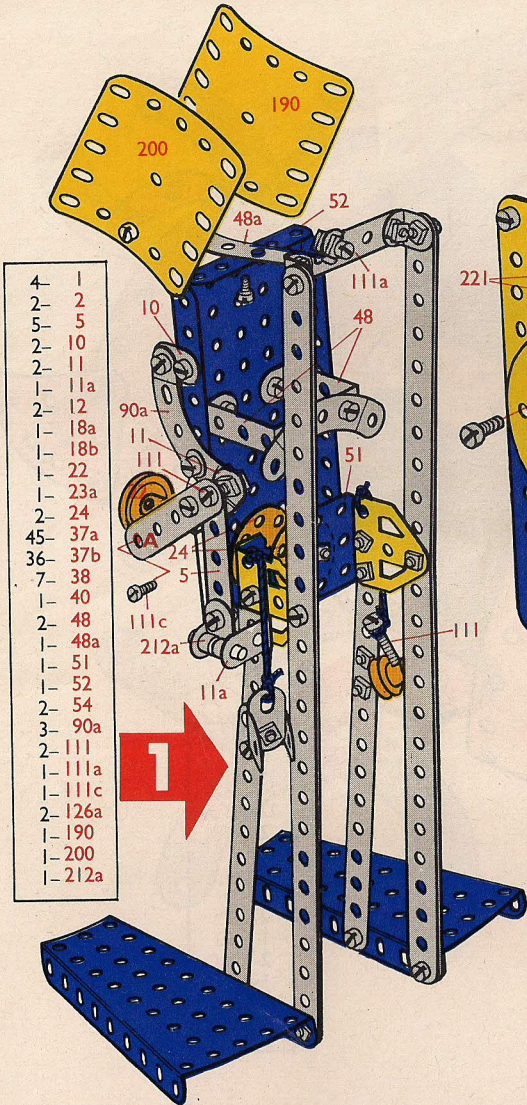

- 4- 1
- 2- 2
- 5- 5
- 2- 10
- 2- 11
- 1- 11a
- 2- 12
- 1- 18a
- 1- 18b
- 1- 22
- 1- 23a
- 2- 24
- 45- 37a
- 36- 37b
- 7- 38
- 1- 40
- 2- 48
- 1- 48a
- 1- 51
- 1- 52
- 2- 54
- 3- 90a
- 2-111
- 1-111a
- 1-111c
- 2-126a
- 1-190
- 1-200
- 1-212a

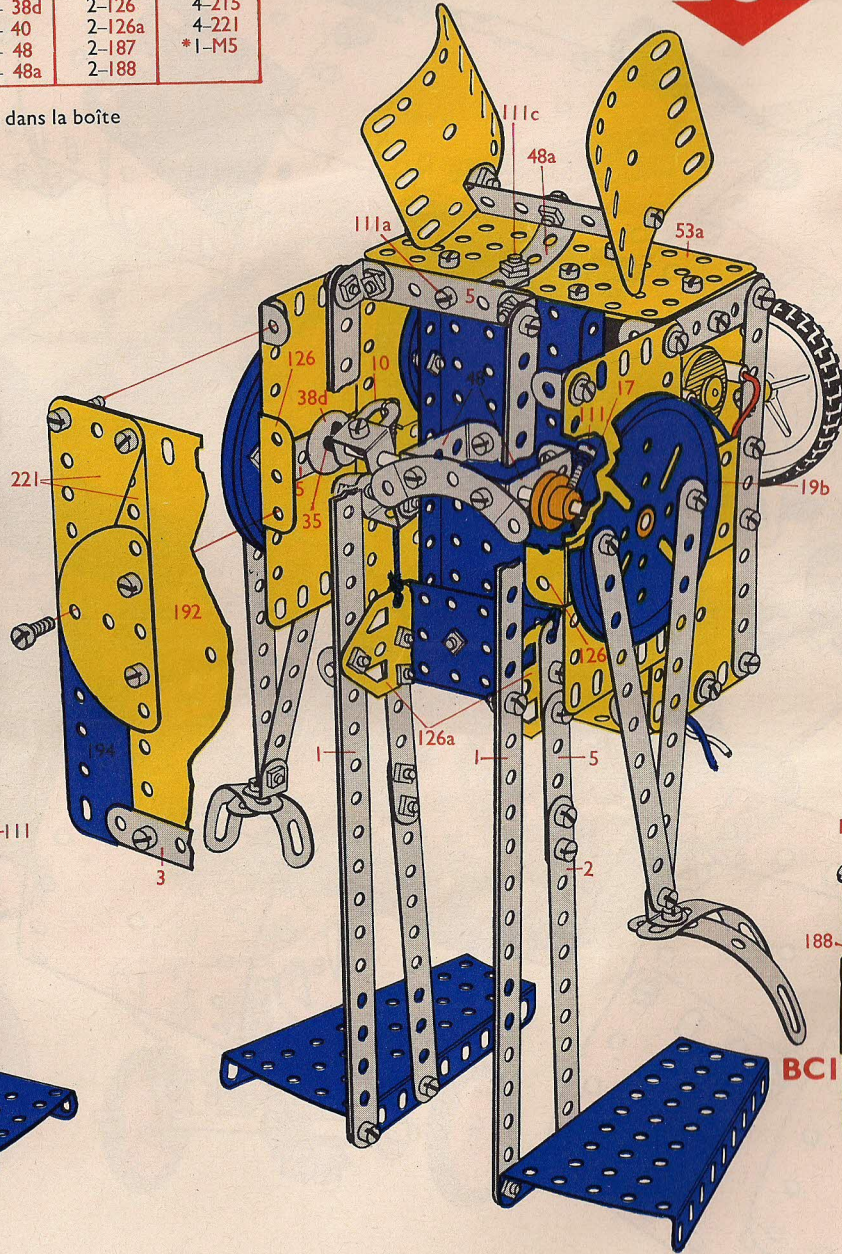

- 4- 2
- 1- 3
- 2- 12
- 2- 17
- 2- 19b
- 2- 35
- 21- 37a
- 19- 37b
- 2- 38d
- 2-111c
- 1-192
- 2-194a
- 2-214
- 4-215
- 4-221

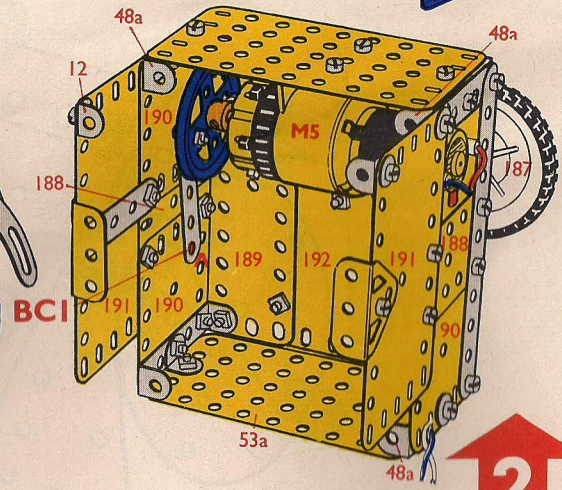
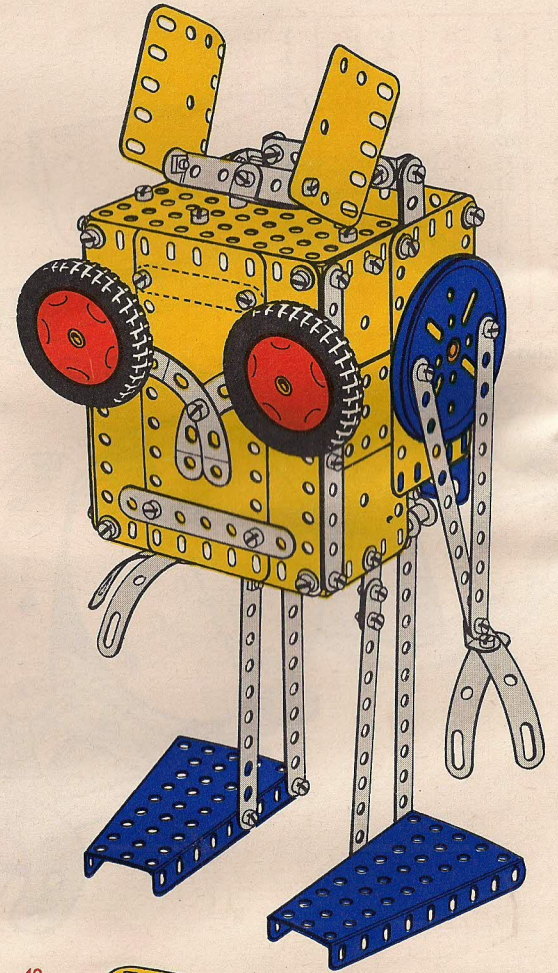

- 2- 2
- 1- 3
- 4- 5
- 6- 12
- 1- 20a
- 39- 37a
- 39- 37b
- 10- 38
- 4- 48a
- 2- 53a
- 1-111c
- 2-126
- 2-187
- 2-188
- 2-189
- 3-190
- 2-191
- 1-192

ELECTRONIQUE

5.16

Presse automatique

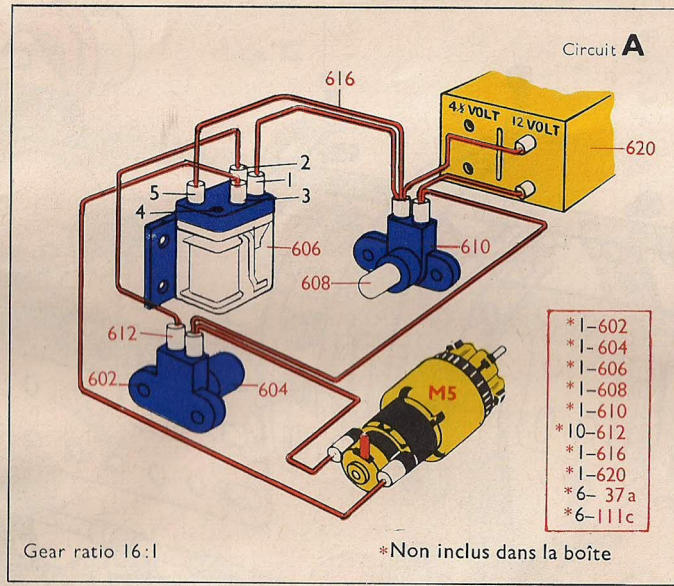

2- 2	2- 35
1- 3	16- 37a
2- 5	14- 38
2- 15b	8- 38
1- 20a	1- 52
2- 22	2- 54
1- 23a	2-111c
*1- 23a	2-126
2- 27f	1-186a

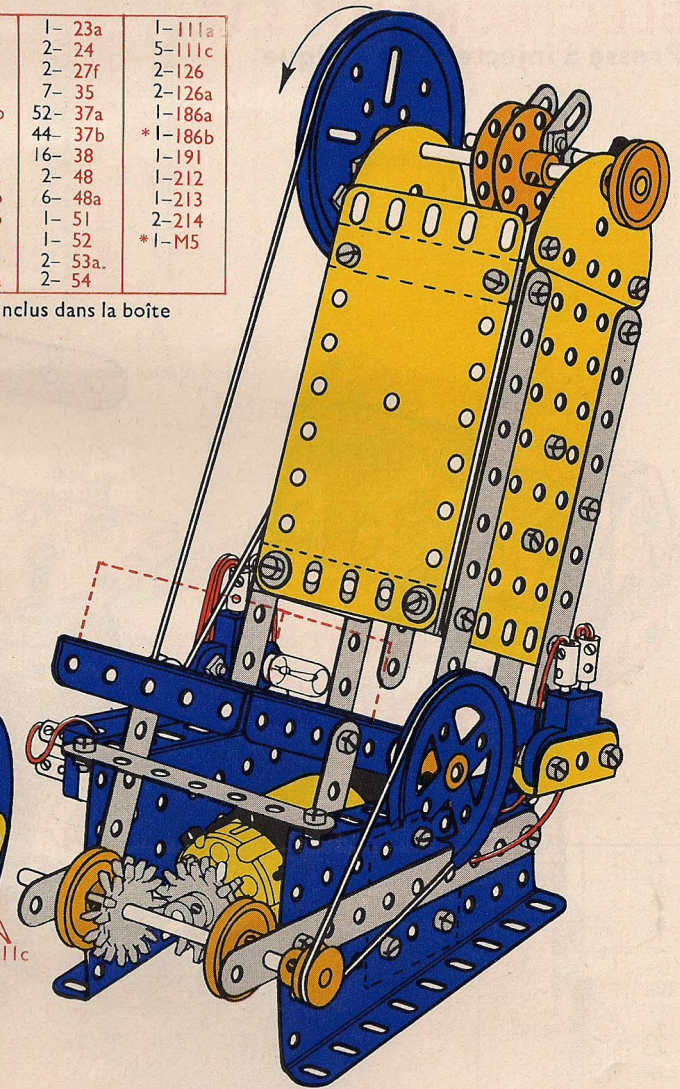
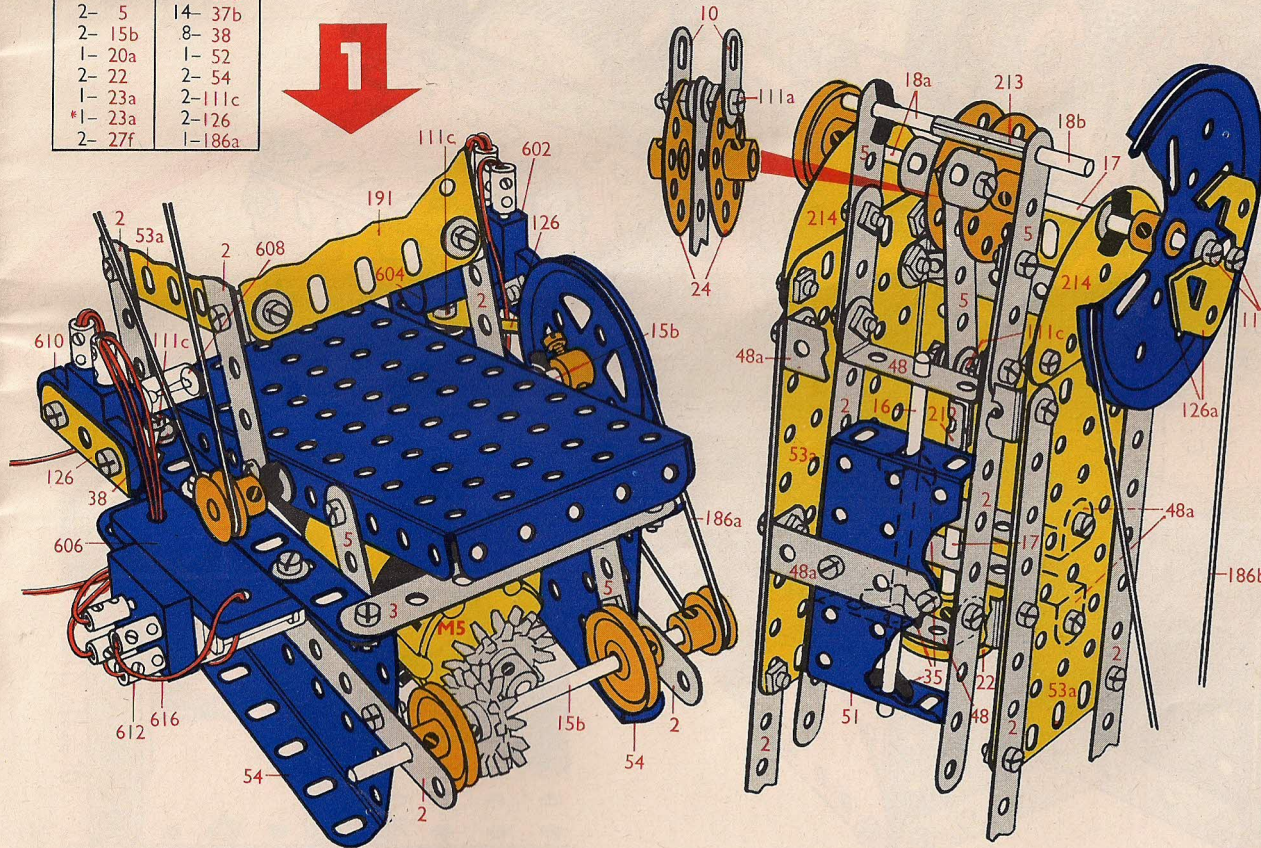

6- 2	2- 24	1-111a
3- 5	5- 35	3-111c
2- 10	29- 37a	2-126a
1- 16	22- 37b	1-186b
1- 17	8- 38	1-191
2- 18a	2- 48	1-212
1- 18b	6- 48a	1-213
1- 19b	1- 51	2-214
2- 22	2- 53a	

ELECTRONIQUE 5.17

Presse à injecter le plastique

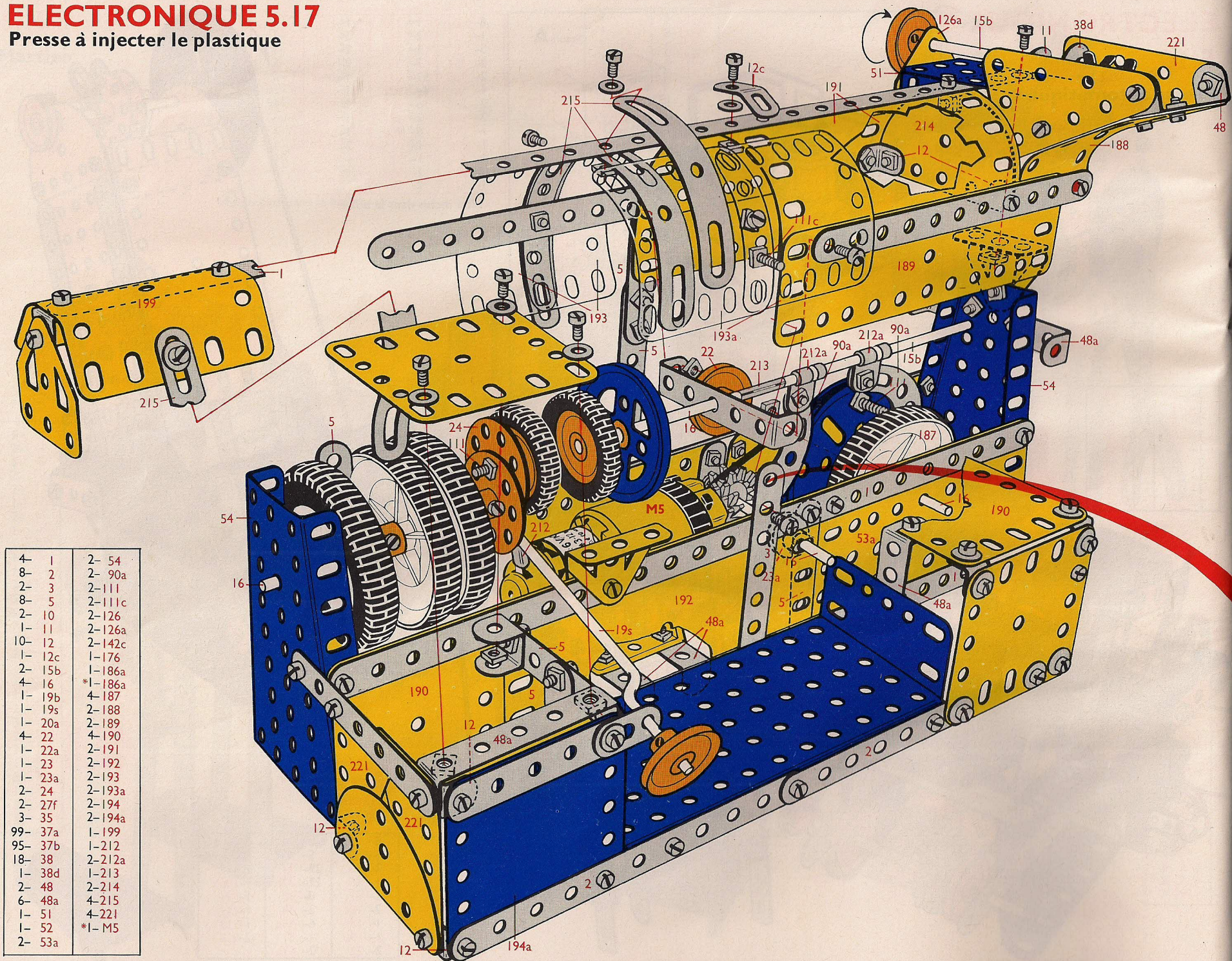

4-	1	2-	54
8-	2	2-	90a
2-	3	2-	111
8-	5	2-	111c
2-	10	2-	126
1-	11	2-	126a
10-	12	2-	142c
1-	12c	1-	176
2-	15b	1-	186a
4-	16	*1-	186a
1-	19b	4-	187
1-	19s	2-	188
1-	20a	2-	189
4-	22	4-	190
1-	22a	2-	191
1-	23	2-	192
1-	23a	2-	193
2-	24	2-	193a
2-	27f	2-	194
3-	35	2-	194a
99-	37a	1-	199
95-	37b	1-	212
18-	38	2-	212a
1-	38d	1-	213
2-	48	2-	214
6-	48a	4-	215
1-	51	4-	221
1-	52	*1-	M5
2-	53a		

Circuit C

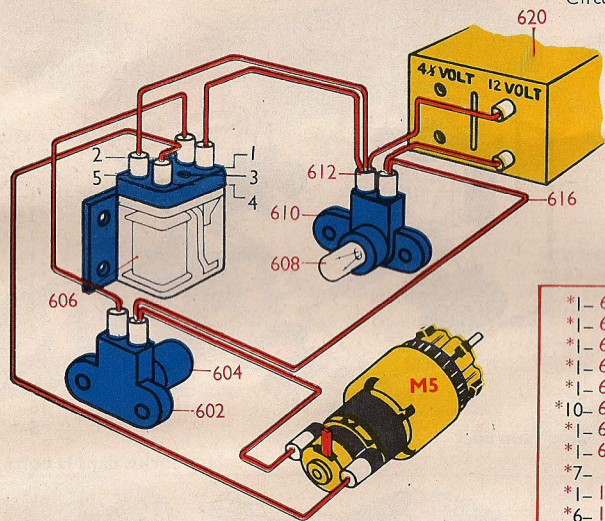

- *1- 602
- *1- 604
- *1- 606
- *1- 608
- *1- 610
- *10- 612
- *1- 616
- *1- 620
- *7- 37a
- *1- 111a
- *6- 111c

4- 1	1- 23	2- 90a	2- 193
8- 2	1- 23a	2- 111	2- 193a
2- 3	2- 24	2- 111c	2- 194
8- 5	2- 27f	2- 126	2- 194a
2- 10	3- 35	2- 126a	1- 199
1- 11	99- 37a	2- 142c	1- 212
10- 12	95- 37b	1- 176	2- 212a
1- 12c	18- 38	1- 186a	1- 213
2- 15b	1- 38d	*1- 186a	2- 214
4- 16	2- 48	4- 187	4- 215
1- 19b	6- 48a	2- 188	4- 221
1- 19s	1- 51	2- 189	*1- M5
1- 20a	1- 52	4- 190	
4- 22	2- 53a	2- 191	
1- 22a	2- 54	2- 192	

*Non inclus dans la boîte

Gear ratio 60:1

*Non inclus dans la boîte

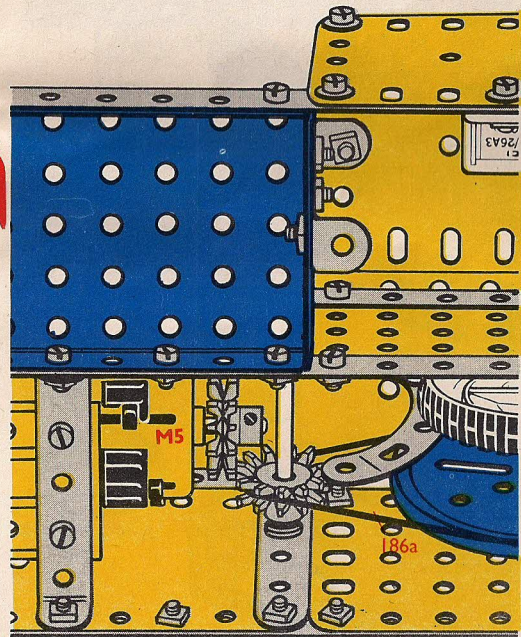
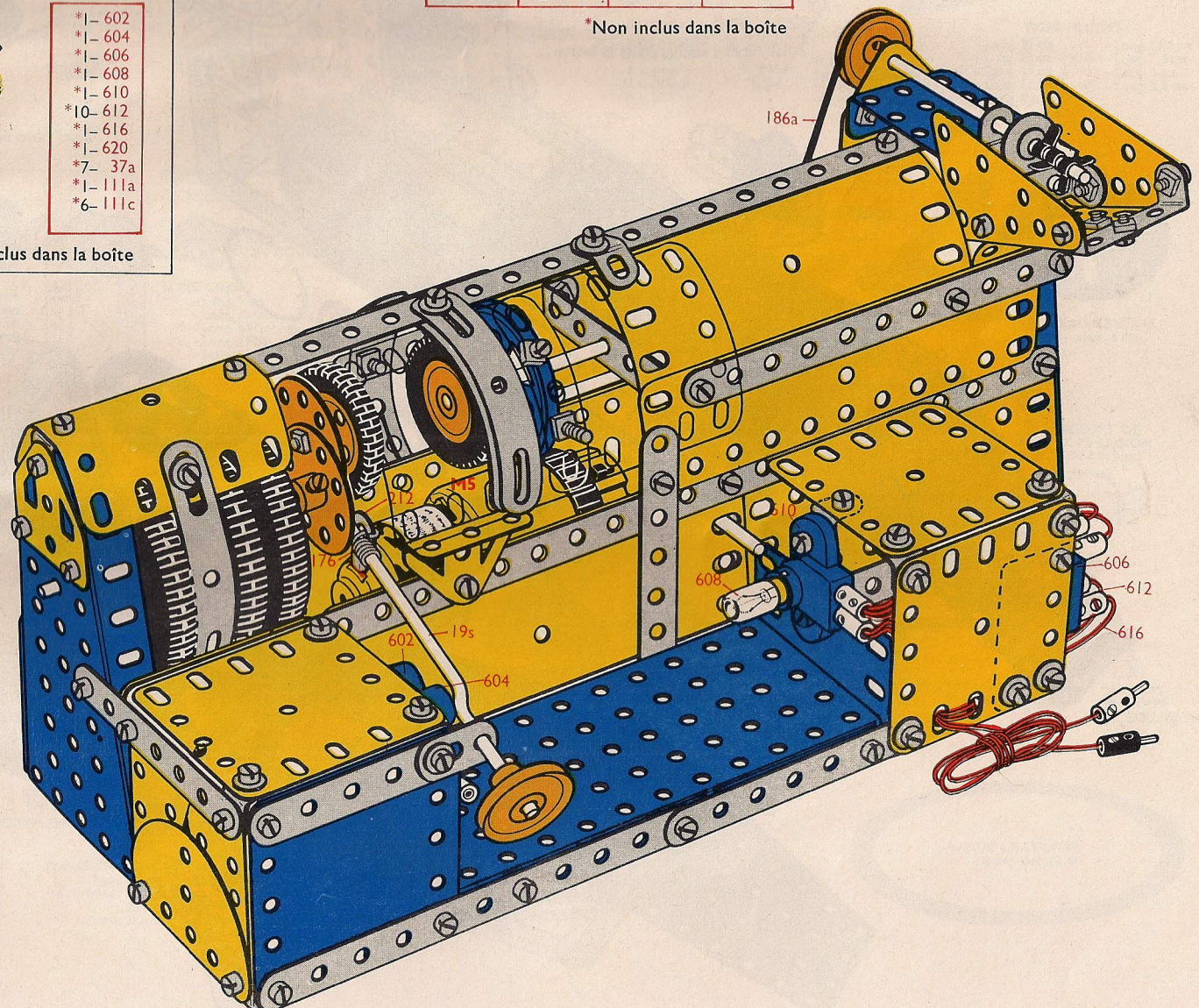

ELECTRONIQUE

5.18

Chaîne de comptage

4- 1	1- 23a	2- 111a
5- 2	2- 24	2- 111c
2- 3	2- 27f	2- 126
9- 5	14- 35	2- 126a
4- 10	87- 37a	1- 155
2- 11	71- 37b	1- 186
1- 11a	18- 38	1- 186a
8- 12	2- 38d	*1- 186a
2- 15b	1- 40	2- 190
4- 16	1- 48	2- 192
1- 17	6- 48a	1- 212
2- 19b	1- 51	2- 212a
1- 20a	1- 52	1- 213
4- 22	2- 53a	2- 214
2- 22a	2- 54	*1- M5
1- 23	4- 90a	
*1- 23a	1- 111	

*Non inclus dans la boîte

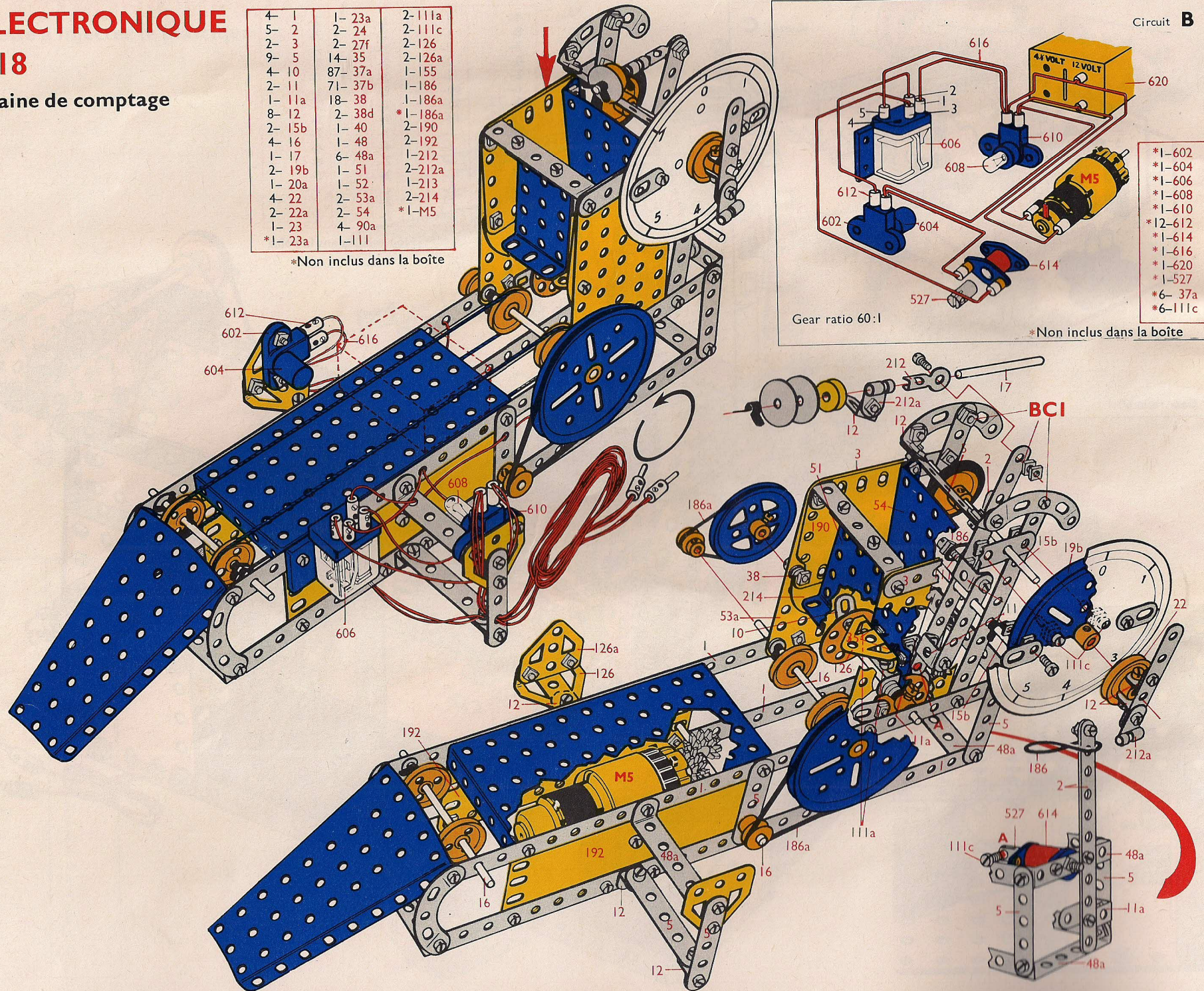

Circuit B

Gear ratio 60:1

*Non inclus dans la boîte

- *1-602
- *1-604
- *1-606
- *1-608
- *1-610
- *12-612
- *1-614
- *1-616
- *1-620
- *1-527
- *6- 37a
- *6-111c

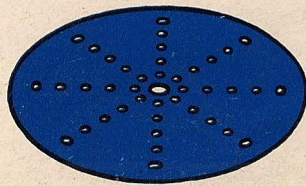

PLAQUES CIRCULAIRES
146 - Diam. 15 cm
146a - Diam. 10 cm



CLIQUET A MOYEU AVEC BOULON-PIVOT ET ECROUS
147



BOULON PIVOT A DEUX ECROUS
147b



ROUE A ROCHET
148



PALANS
151 - Palan à 1 poulie
153 - Palan à 3 poulies



EQUERRE D'ANGLE
154a - 12 mm (droit)
154b - 12 mm (gauche)



ANNEAU DE CAOUTCHOUC
155 - 25 mm



TURBINE
157 - Diam. 5 cm

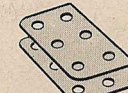

SUPPORT EN U
160 - 38 x 25 x 13 mm

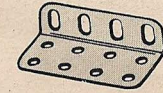

EQUERRE CORNIERE
161 - 50 x 25 x 13 mm

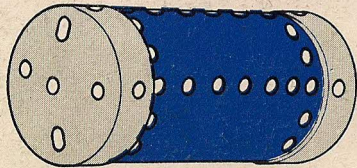

CHAUDIERE COMPLETE AVEC JOUES
162 - 12,5 x 5 cm
162a - JOUE DE CHAUDIERE 50 x 19 mm
162b - CORPS DE CHAUDIERE



MANCHON
163 - 38 x 17 mm



ACCOUPLMENT A CARDAN
165



CHAPE D'ARTICULATION
166



PIGNON A GRANDES DENTS POUR SECTEUR
167c



COURONNE A REBORD POUR ROULEMENT A GALETS
167b - Diam. 25 cm

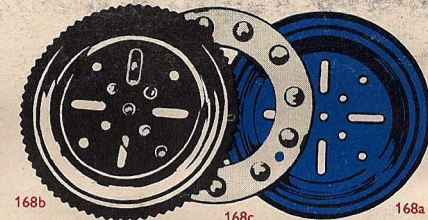

168b - ROULEMENT A BILLES COMPLET
168a - PLATEAU A REBORD DE ROULEMENT A BILLES
168b - PLATEAU A DENTURE DE ROULEMENT A BILLES
168c - ANNEAU MONTE AVEC BILLES



BILLE
168d - diam. 9,5 mm



COLLIER TARAUDE A CHEVILLE
173a



COLLIER AVEC TIGE FILETEE
179



COURONNE A DOUBLE DENTURE
180 - diam. 9 cm



VOLANTS D'AUTOMOBILE
185 - 45 mm
185a - 60 mm



COURROIES DE TRANSMISSION
186 - 65 mm, lég.
186a - 15 cm, lég.
186b - 25 cm, lég.
186c - 25 cm épaisse
186d - 38 cm épaisse
186e - 50 cm épaisse



ROUES D'AUTO
187 - 60 mm
187b - 108 mm



FLASQUE DE ROUE
187a - 47 mm



ACCOUPLMENT JUMELE A DOUILLE
171



RESSORT D'ATTACHE POUR CORDE MECCANO
176



JOINT FLEXIBLE
175

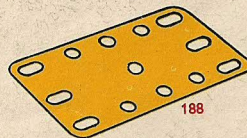

PLAQUES FLEXIBLES
188 - 6 x 4 cm
189 - 14 x 4 cm
190 - 6 x 6 cm
190a - 9 x 6 cm
191 - 11,5 x 6 cm
192 - 14 x 6 cm

PLAQUES TRANSPARENTES
193 - 6 x 4 cm
193a - 6 x 6 cm

193b - 9 x 6 cm
193c - 11,5 x 6 cm
193d - 14 x 4 cm
193e - 14 x 6 cm

PLAQUES PLASTIQUES BLEUES

194 - 6 x 4 cm
194a - 6 x 6 cm
194b - 9 x 6 cm
194c - 11,5 x 6 cm
194d - 14 x 4 cm
194e - 14 x 6 cm

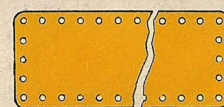

PLAQUES-BANDES
195 - 19 x 6 cm
196 - 24 x 6 cm
197 - 32 x 6 cm

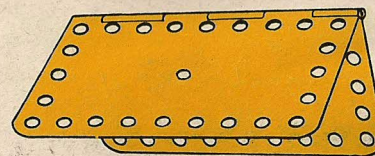

PLAQUE A CHARNIERE
198 - 11,5 x 6 cm

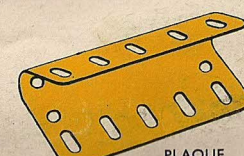

PLAQUE CINTREE EN "U"
199 - 60 x 60 x 7 mm

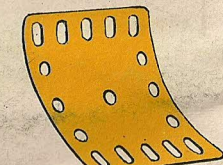

PLAQUE CINTREE
200 - Rayon 43 mm

BANDE CINTREE A GLISSIERES
215 - 75 mm

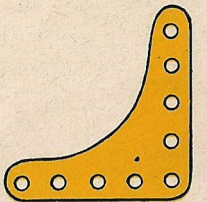

PLAQUE GOUSSET FLEXIBLE
201 - 60 x 60 mm



PIGNON ET ROUE HELICOIDAUX
211a - Diam. 14 mm
211b - Diam. 35 mm



RACCORD TRINGLE ET BANDE
212a

RACCORD TRINGLE ET BANDE A ANGLE DROIT
212a



213 RACCORD TRINGLES
213a RACCORD DE TRINGLES TRIPLE
213b RACCORD DE TRINGLES TRIPLE A MOYEU



PLAQUE SEMI-CIRCULAIRE
214 - 65 mm

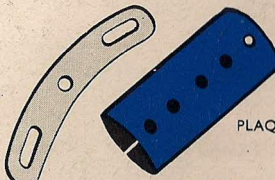

CYLINDRE
216 - 6 x 3 cm

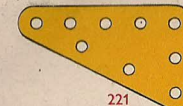

PLAQUES FLEXIBLES TRIANGULAIRES
221 - 6 x 4 cm
222 - 6 x 5 cm
223 - 6 x 6 cm
224 - 9 x 4 cm
225 - 9 x 5 cm
226 - 9 x 6 cm

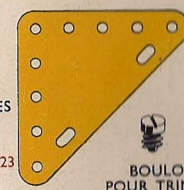

BOULON POUR TRINGLE A CANNELURE
231



TRINGLE A CANNELURE
230 10 cm

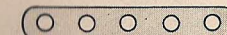

BANDES ETROITES
235 - 5 trous 60 mm x 9 mm
235a - 6 trous 75 mm x 9 mm
235b - 7 trous 90 mm x 9 mm
235d - 9 trous 115 mm x 9 mm
235f - 11 trous 140 mm x 9 mm