

5.1.

Car Ferry
Autovervoerboot
Ferry-boat pour voitures
Traghetto per automobili
Autofähre
Bilfärja
Buque transbordador de vehiculos
Ferry-boat
Bilferge

4- 1	2- 35	2-126
8- 2	107- 37a	2-126a
2- 3	93- 37b	4-142c
8- 5	11- 38	2-155
3-10	2- 38d	2-188
2-11	1- 40	2-189
1-11a	2- 48	4-190
10-12	5- 48a	2-191
1-12c	1- 51	2-192
4-16	1- 52	1-193
1-18a	2- 53a	2-194
1-18b	2- 54	1-212
4-22	2- 90a	2-212a
2-22a	2-111	2-214
1-23	4-111c	4-221
2-24	2-125	

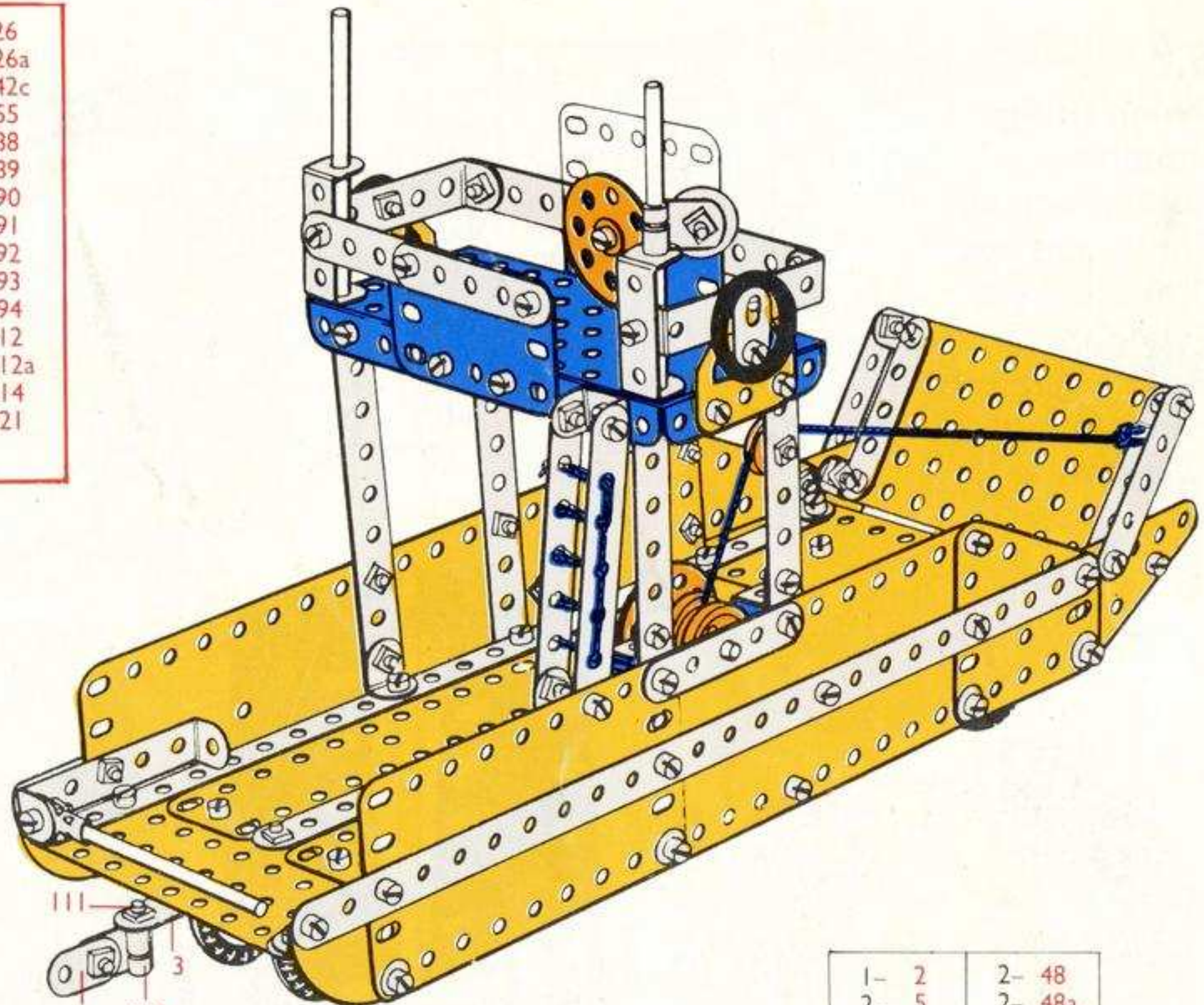

4- 1	1- 40
7- 2	3- 48a
2- 3	1- 51
6- 5	2- 53a
1-10	2- 54
2-11	2- 90a
1-11a	1-111
10-12	2-111c
1-12c	2-125
2-16	2-126
1-18a	4-142c
1-18b	2-188
4-22	2-189
2-22a	4-190
1-23	2-191
1-24	2-192
81-37a	1-212
73-37b	1-212a
10-38	2-214
1-38d	4-221

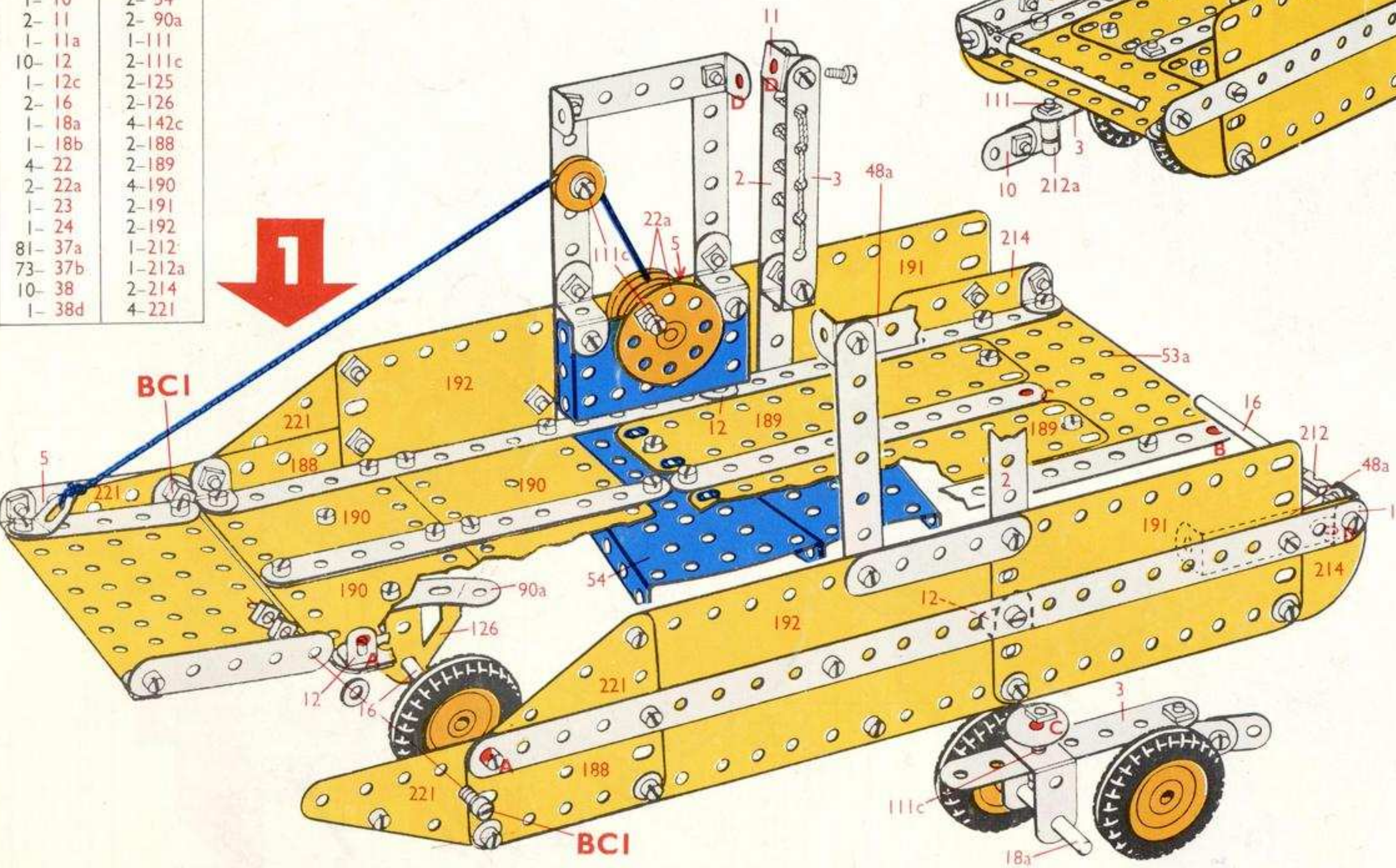

1- 2	2- 48
2- 5	2- 48a
2-10	1- 52
2-16	1-111
1-24	2-111c
2-35	2-126a
26-37a	2-155
20-37b	1-193
1-38	2-194
1-38d	1-212a

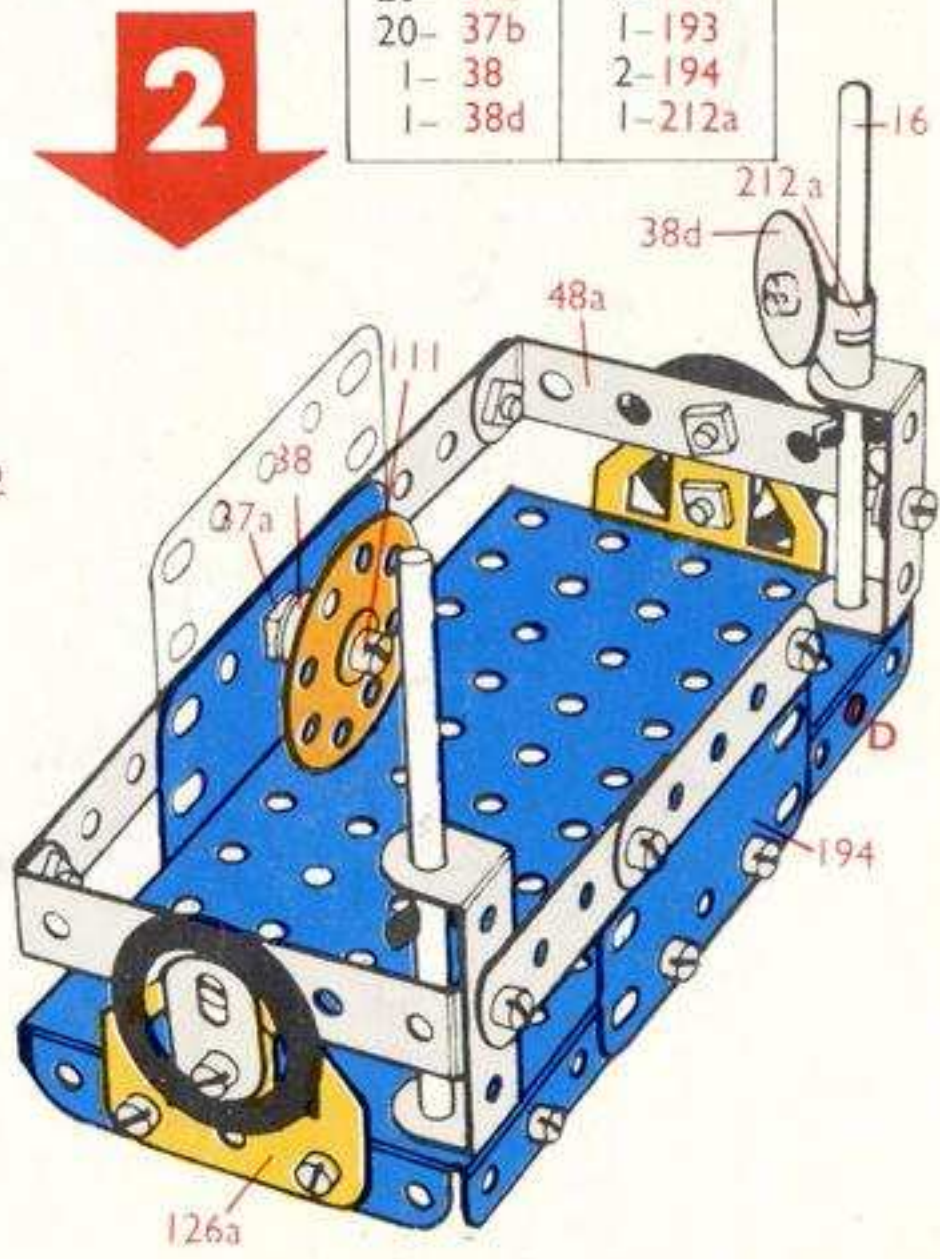

5.2.

Swing Bridge
 Draaibrug
 Pont basculant
 Ponte girevole
 Drehbrücke
 Svängbro
 Puente giratorio
 Ponte levadiça
 Svingbro

4- 1	2- 24	4-111c
8- 2	2- 27f	2-125
2- 3	4- 35	2-126
9- 5	101- 37a	2-126a
4- 10	93- 37b	2-188
1- 11	13- 38	2-189
9- 12	1- 40	4-190
2- 12c	6- 48a	2-191
1- 15b	1- 51	2-192
3- 16	1- 52	2-194
1- 19s	2- 53a	2-212a
1- 20a	2- 54	2-214
3- 22	4- 90a	4-221
1- 23a	2-111a	

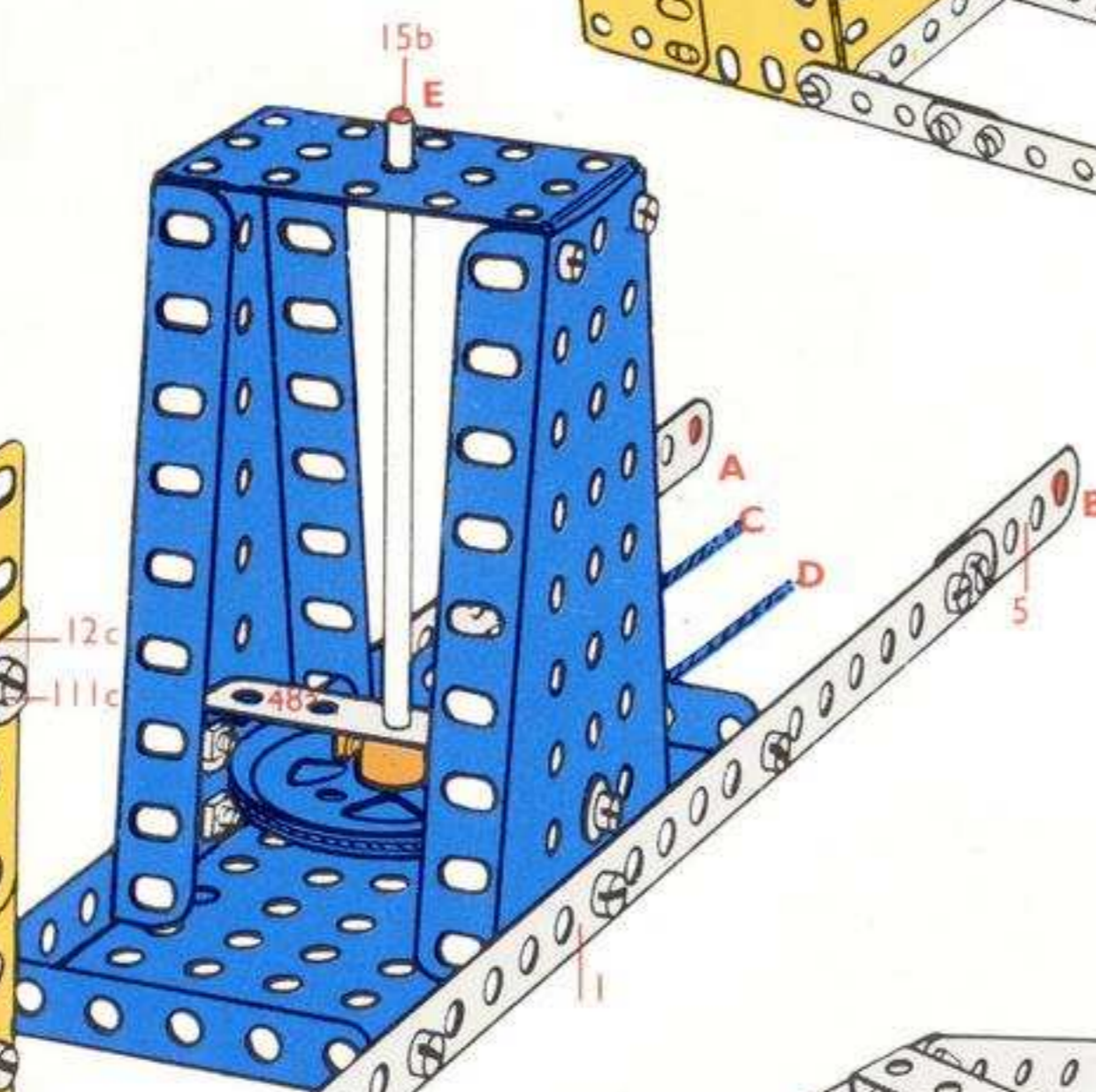
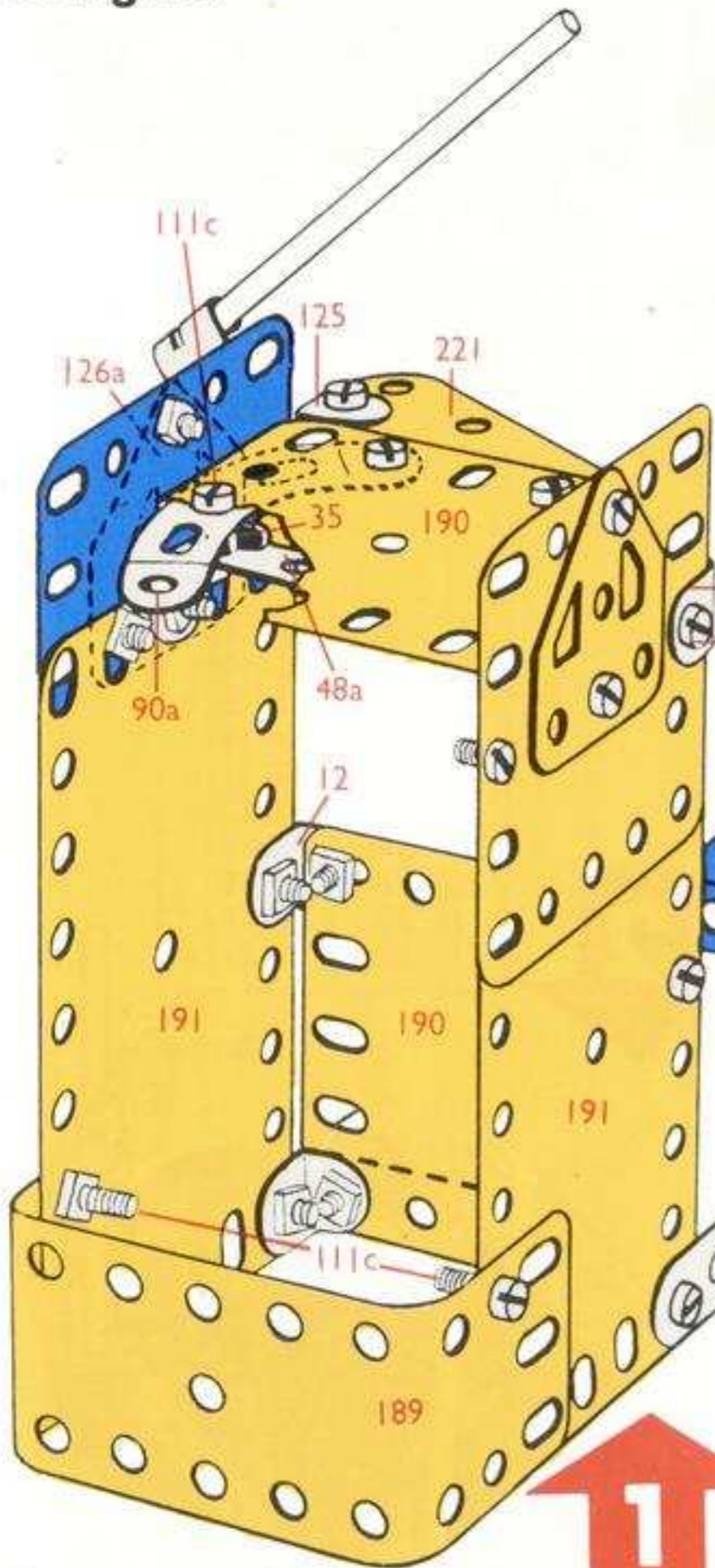
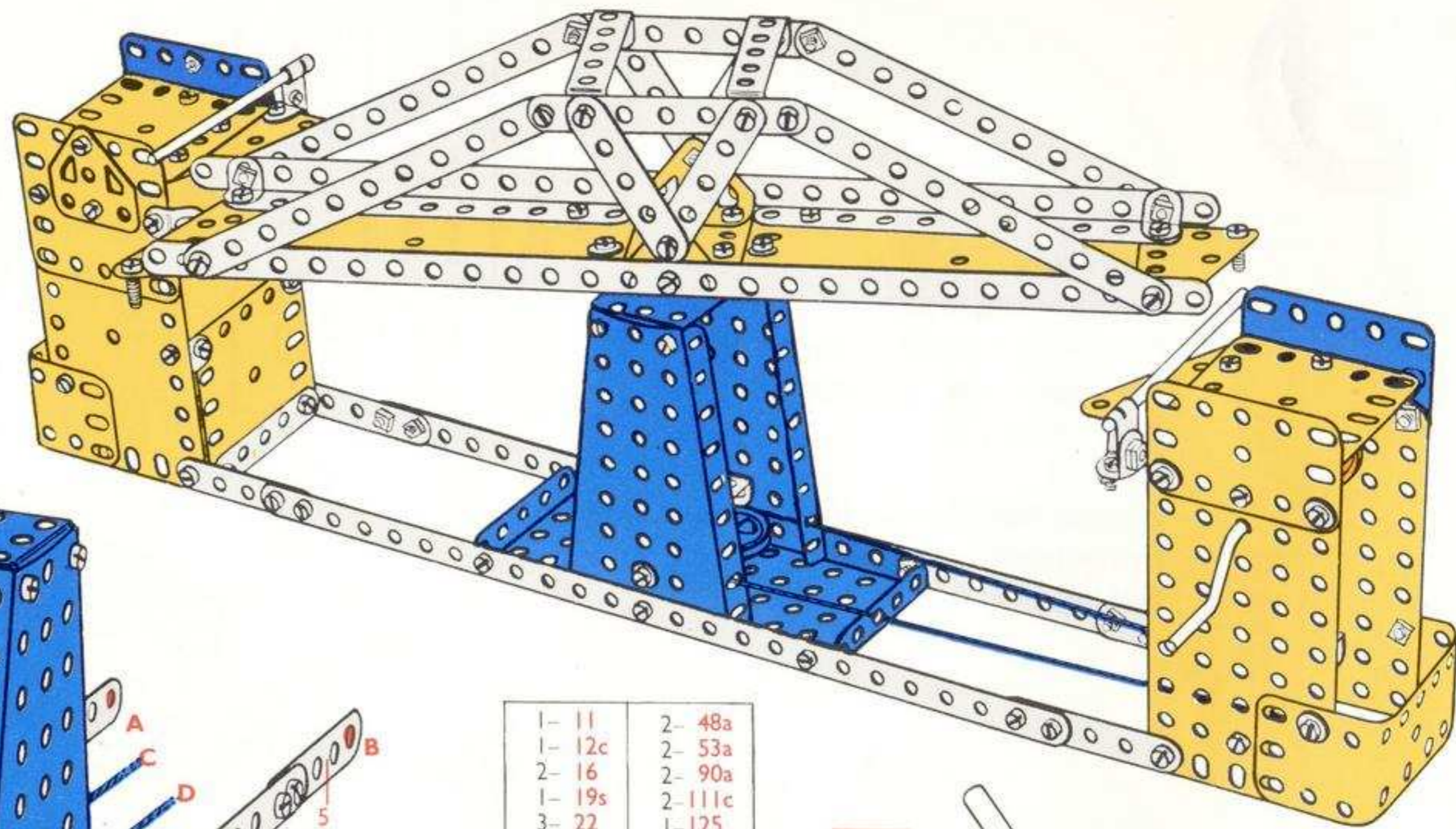

1- 11	2- 48a
1- 12c	2- 53a
2- 16	2- 90a
1- 19s	2-111c
3- 22	1-125
1- 23a	1-188
1- 24	1-189
2- 27f	1-190
2- 35	1-194
20- 37a	1-212a
17- 37b	1-221
9- 38	

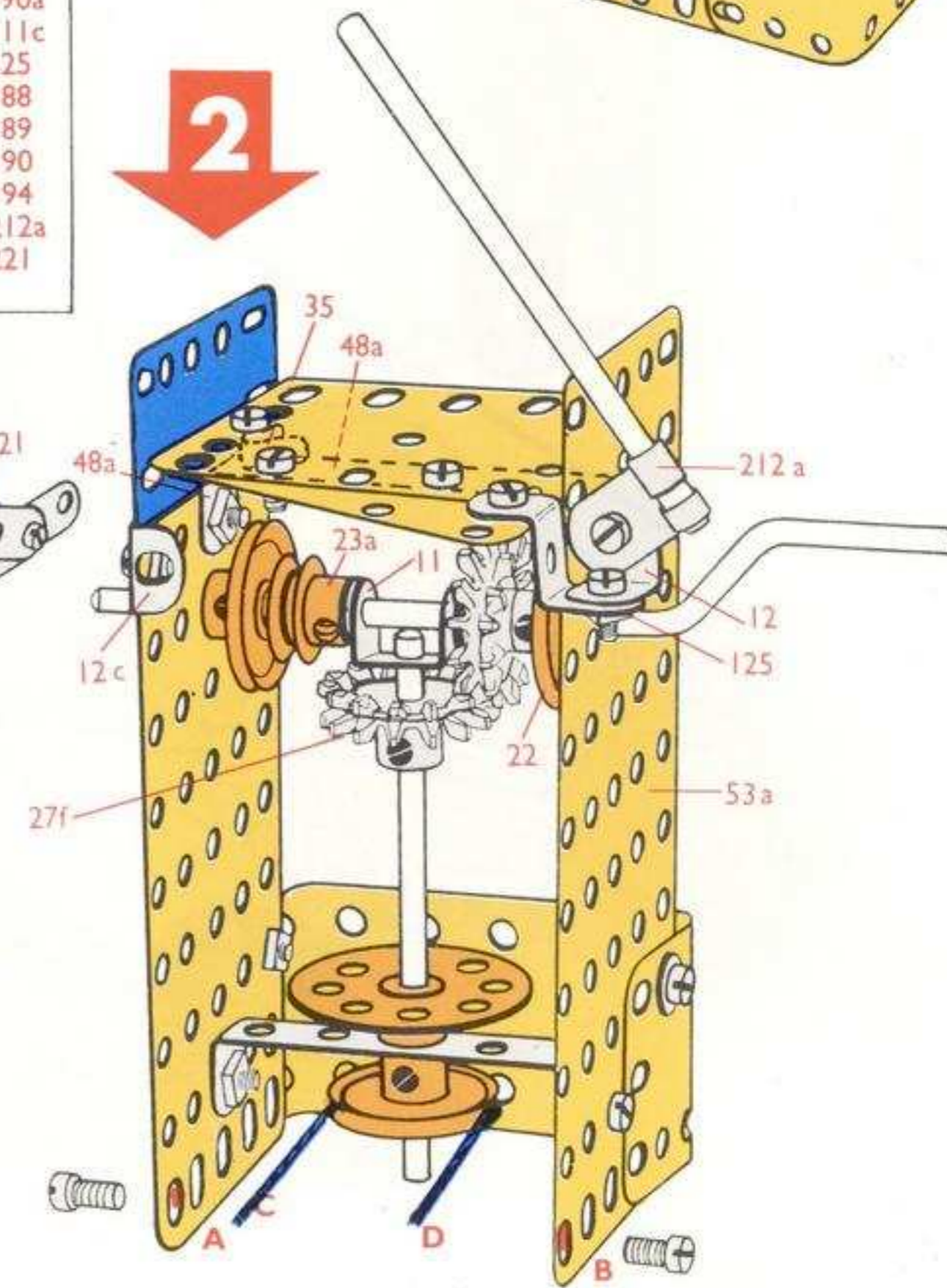
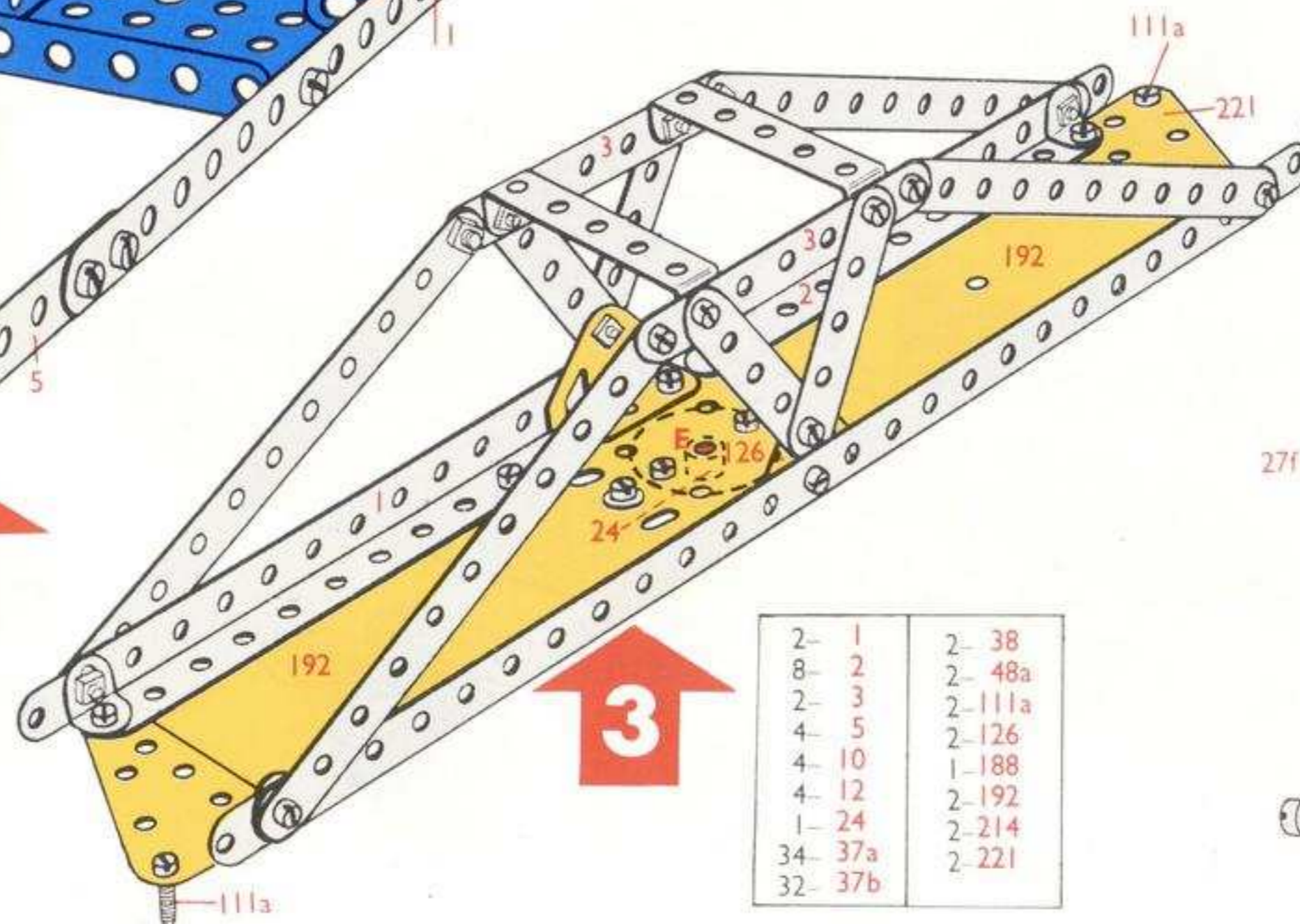

2- 1	44- 37b	1-125
5- 5	2- 38	2-126a
5- 12	1- 40	1-189
1- 12c	2- 48a	3-190
1- 15b	1- 51	2-191
1- 16	1- 52	1-194
1- 20a	2- 54	1-212a
2- 35	2- 90a	1-221
47- 37a	4-111c	

2- 1	2- 38
8- 2	2- 48a
2- 3	2-111a
4- 5	2-126
4- 10	1-188
4- 12	2-192
1- 24	2-214
34- 37a	2-221
32- 37b	

5.3.

Heavy Goods Lorry
 Zware vrachtwagen
 Camion poids-lourd
 Autocarro per servizio pesante
 Schwerlastwagen
 Tung lastbil
 Camión de mercancías pesadas
 Camião de carga
 Tung lastebil

4- 1	2- 22	1- 52	2-189
8- 2	2- 22a	2- 53a	4-190
2- 3	1- 23	3- 90a	2-191
9- 5	1- 23a	1-111	2-192
4-10	1- 24	1-111a	2-193
2-11	8- 35	6-111c	1-193a
1-11a	107-37a	2-125	2-194a
6-12	93- 37b	2-126	2-212a
1-12c	14- 38	2-126a	1-213
2-16	2- 38d	1-155	2-214
2-17	2- 48	*1-186b	4-215
2-18a	6- 48a	4-187	4-221
1-18b	1- 51	2-188	*1-M2

* Non inclus dans la boîte
 * Not included in set

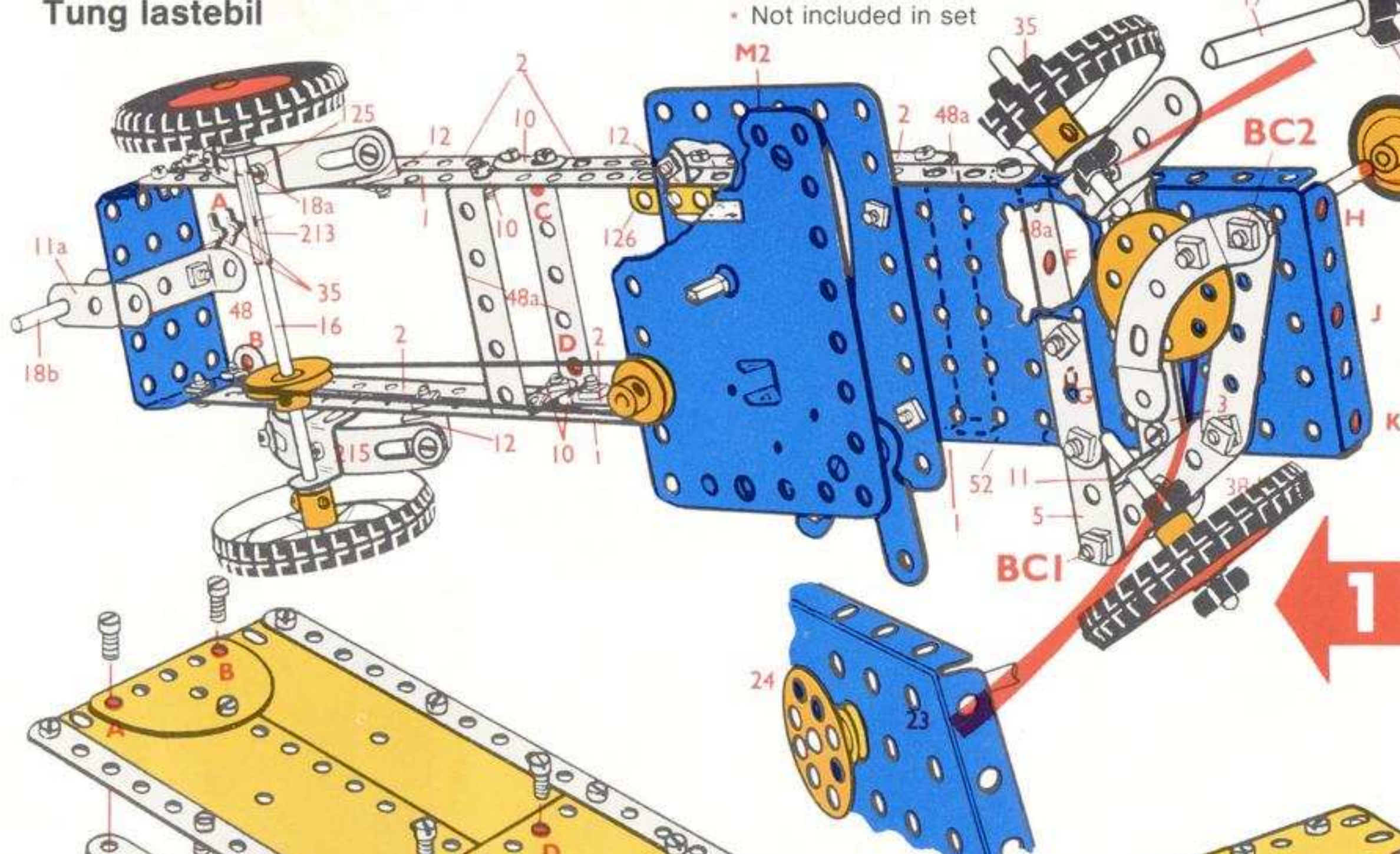
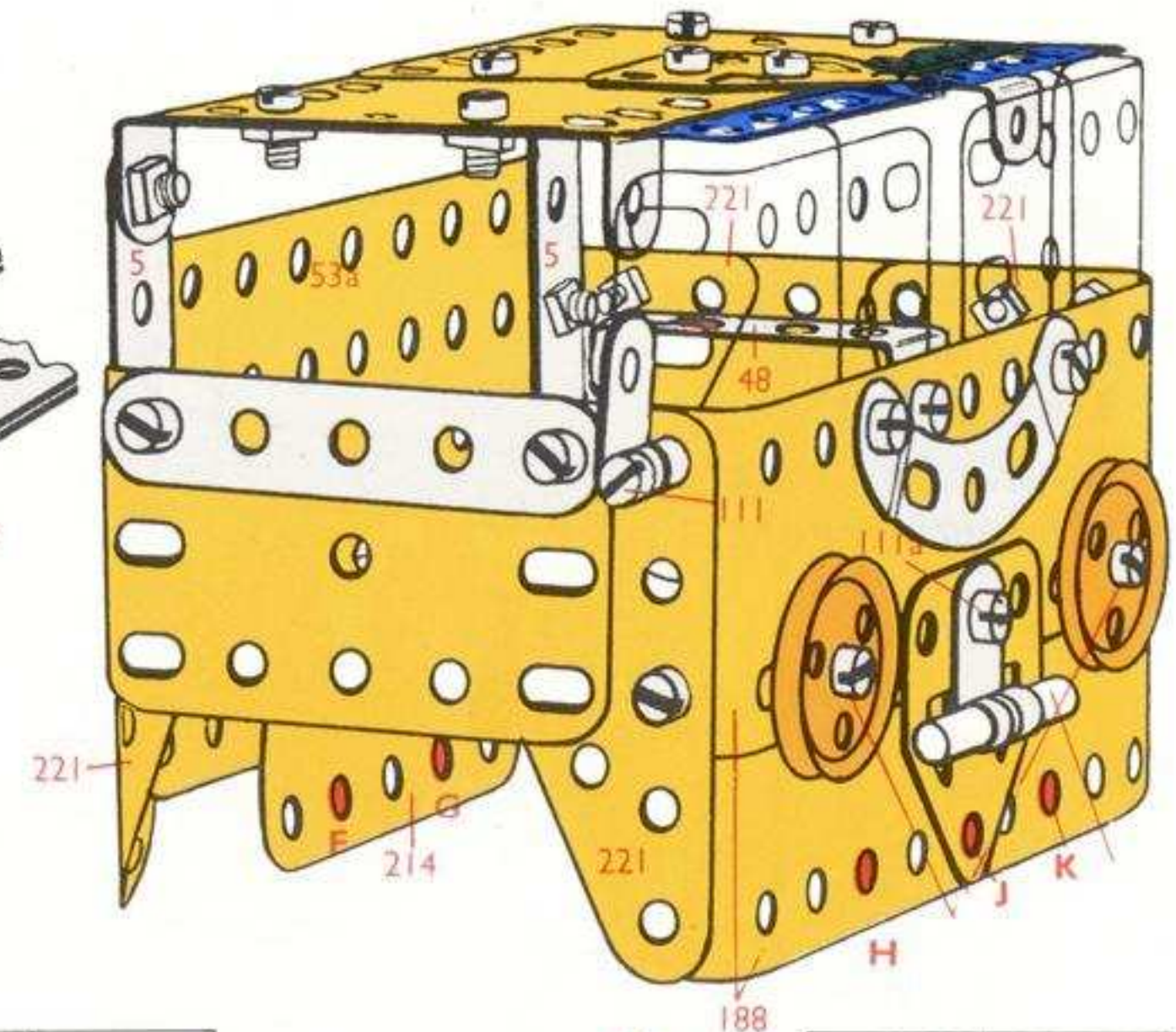

2- 1	53- 37a
4- 2	43- 37b
2- 3	14- 38
5- 5	2- 38d
4-10	1- 48
2-11	4- 48a
1-11a	1- 51
6-12	1- 52
2-16	1- 90a
2-17	4-111c
1-18a	2-125
1-18b	2-126
2-22	1-155
1-23	*1-186b
1-23a	4-187
1-24	1-213
8- 35	2-215

4- 5	2-111c
1-12c	2-126a
1-18a	2-188
2-22a	2-189
31-37a	2-190
27-37b	2-193
1- 48	1-193a
2- 48a	2-194a
1- 53a	2-212a
2- 90a	1-214
1-111	4-221
1-111a	

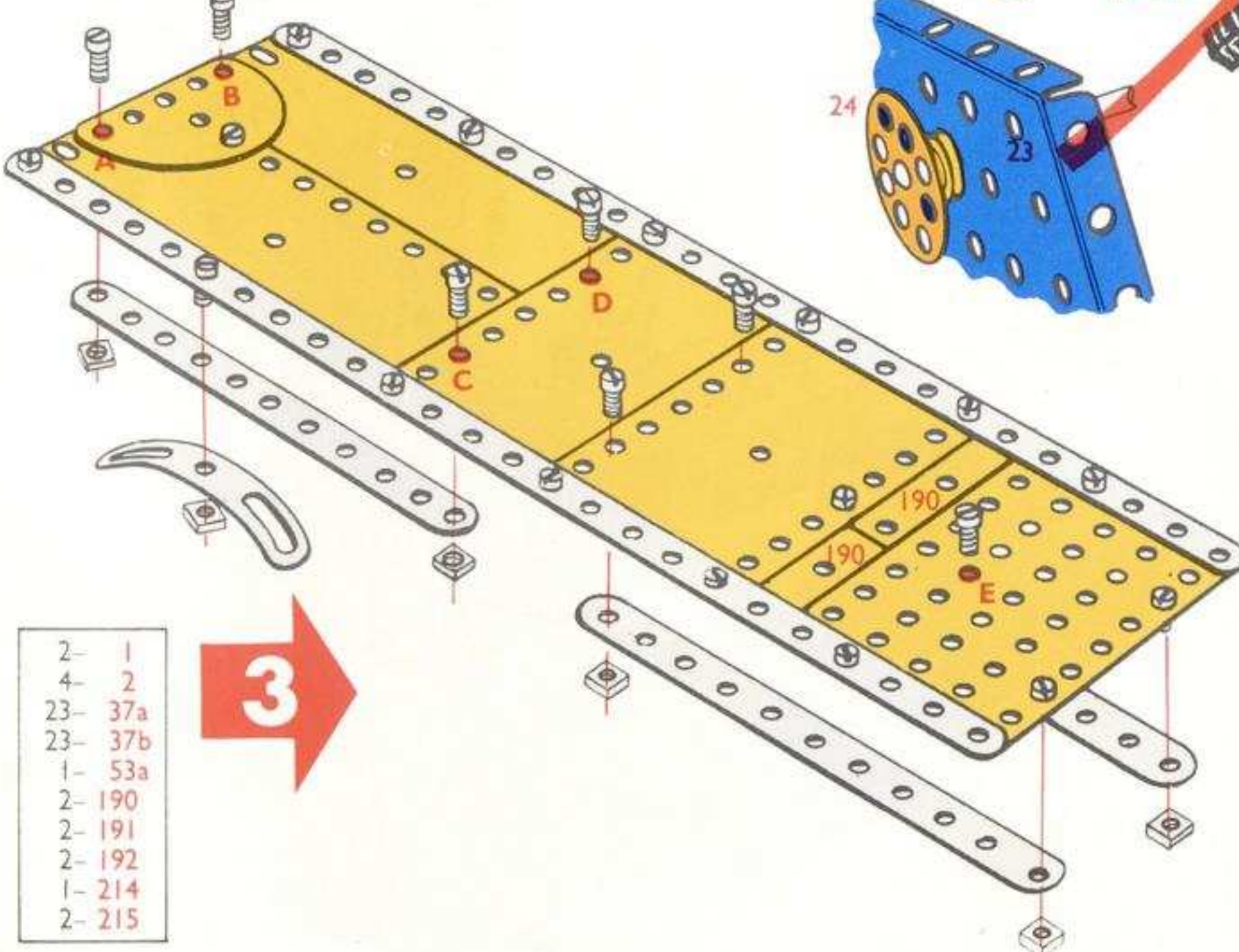

2- 1
4- 2
23- 37a
23- 37b
1- 53a
2- 190
2- 191
2- 192
1- 214
2- 215

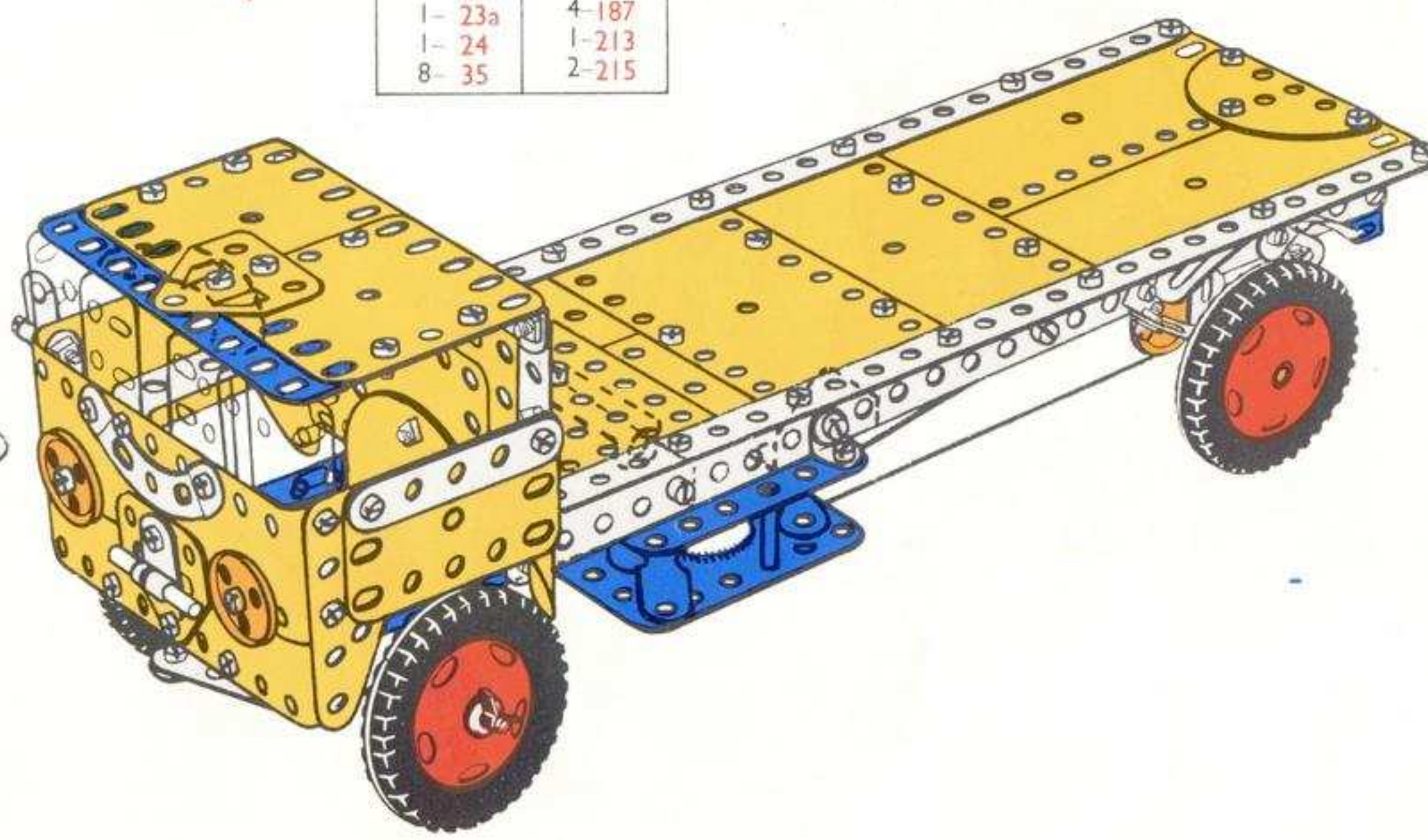

5.4.

Moon Explorer
Maanvoertuig
Engin d'exploration lunaire
Esploratore lunare
Mondfahrzeug
Månfarkost
Explorador lunar
Måneutforsker

4- 1	1- 18a	2- 48	1- 176
8- 2	1- 18b	6- 48a	1- 186
2- 3	1- 19s	1- 51	3- 187
7- 5	1- 20a	1- 52	2- 188
4- 10	4- 22	2- 53a	2- 192
2- 11	1- 22a	2- 54	1- 212
1- 11a	2- 24	2- 90a	1- 212a
10- 12	9- 35	1- 111a	1- 213
4- 12c	105- 37a	6- 111c	1- 215
1- 15b	83- 37b	1- 126	2- 221
2- 16	8- 38	3- 142c	
2- 17	1- 40	1- 155	

1- 2	4- 38
7- 5	1- 40
1- 11a	1- 48
2- 12	2- 90a
1- 16	1- 111a
1- 19s	6- 111c
1- 20a	1- 176
1- 22	1- 186
5- 35	2- 188
40- 37a	2- 221
18- 37b	

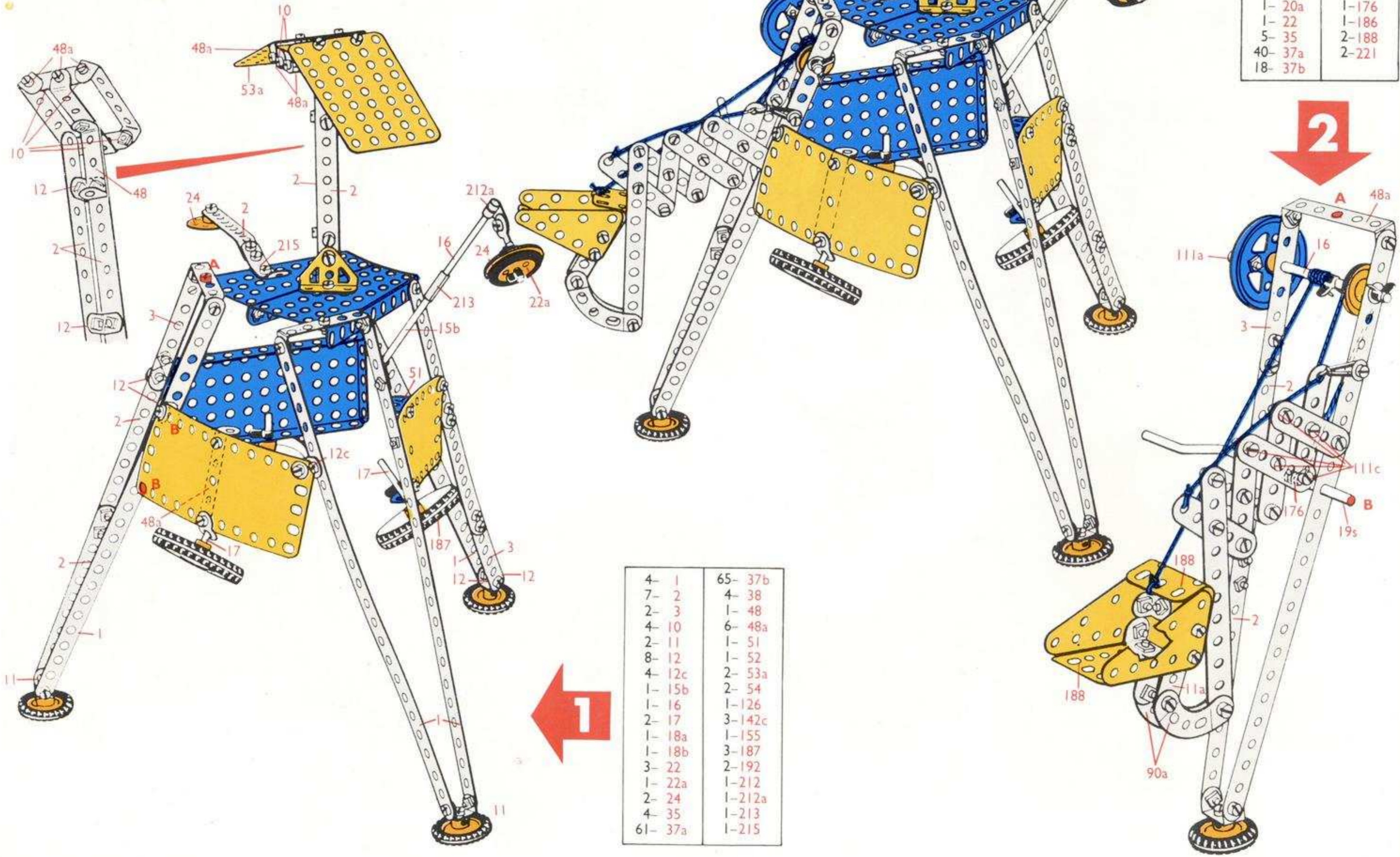

4- 1	65- 37b
7- 2	4- 38
2- 3	1- 48
4- 10	6- 48a
2- 11	1- 51
8- 12	1- 52
4- 12c	2- 53a
1- 15b	2- 54
1- 16	1- 126
2- 17	3- 142c
1- 18a	1- 155
1- 18b	3- 187
3- 22	2- 192
1- 22a	1- 212
2- 24	1- 212a
4- 35	1- 213
61- 37a	1- 215

5.5.

Car Ramp
 Auto-oprit
 Rampe pour voitures
 Rampa per auto
 Autorampe
 Bilbrygga
 Rampa para automóviles
 Rampa para automóveis
 Bilrampe

4- 1	1- 18b	1- 40	4- 142c
8- 2	1- 19s	1- 48	1- 186
2- 3	1- 20a	6- 48a	2- 188
9- 5	4- 22	1- 52	2- 189
4- 10	2- 22a	2- 53a	2- 191
2- 11	2- 24	2- 54	2- 192
4- 12	7- 35	3- 90a	1- 193
2- 12c	74- 37a	5- 111c	2- 212a
1- 15b	66- 37b	2- 125	2- 221
2- 16	14- 38	2- 126	
1- 17	2- 38d	2- 126a	

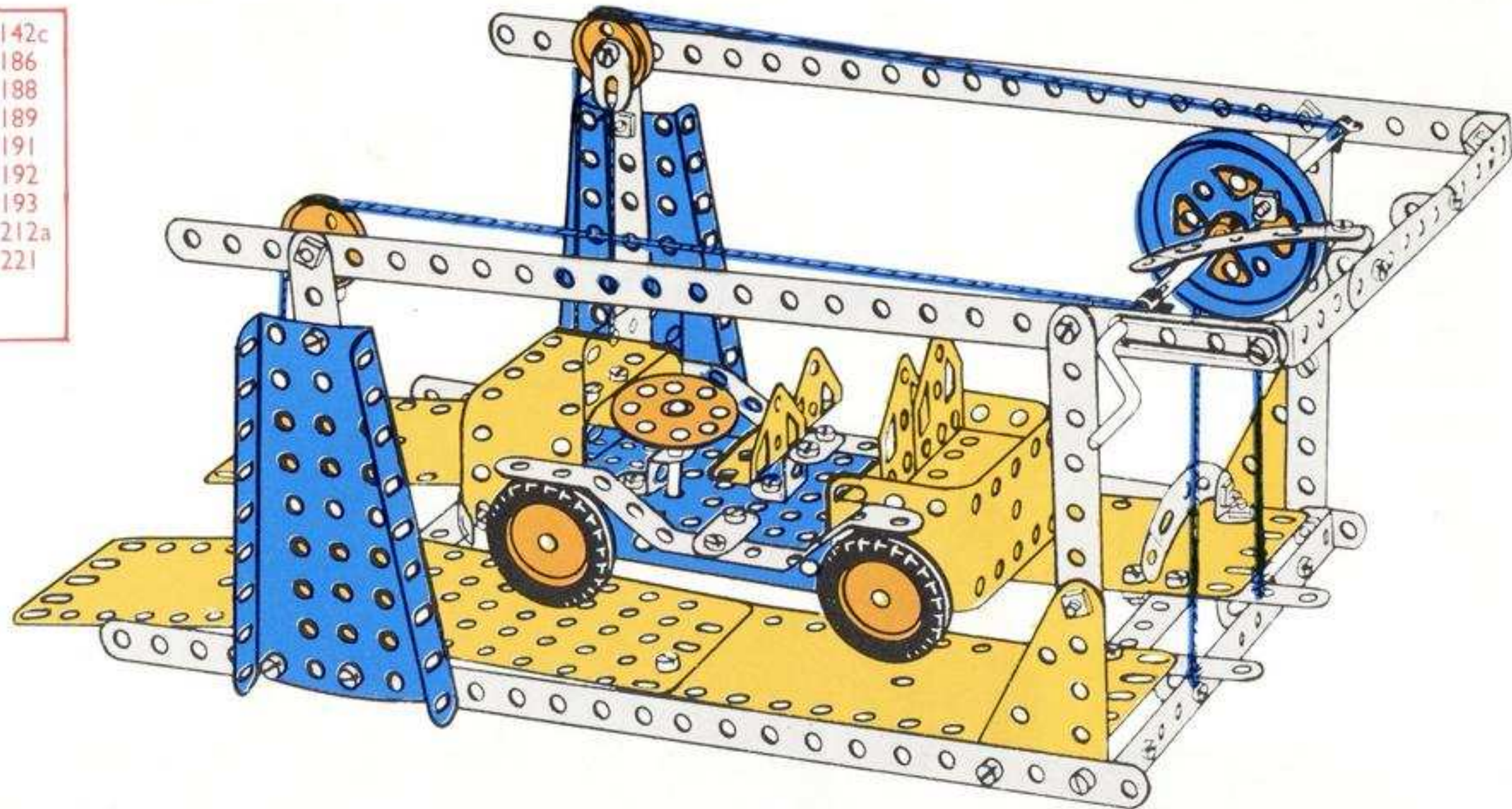

4- 1	1- 20a	6- 48a
6- 2	2- 22a	2- 53a
2- 3	1- 24	2- 54
9- 5	5- 35	3- 90a
2- 10	56- 37a	5- 111c
1- 11	48- 37b	1- 186
2- 12	4- 38	2- 191
1- 15b	2- 38d	2- 192
1- 18b	1- 40	2- 212a
1- 19s	1- 48	2- 221

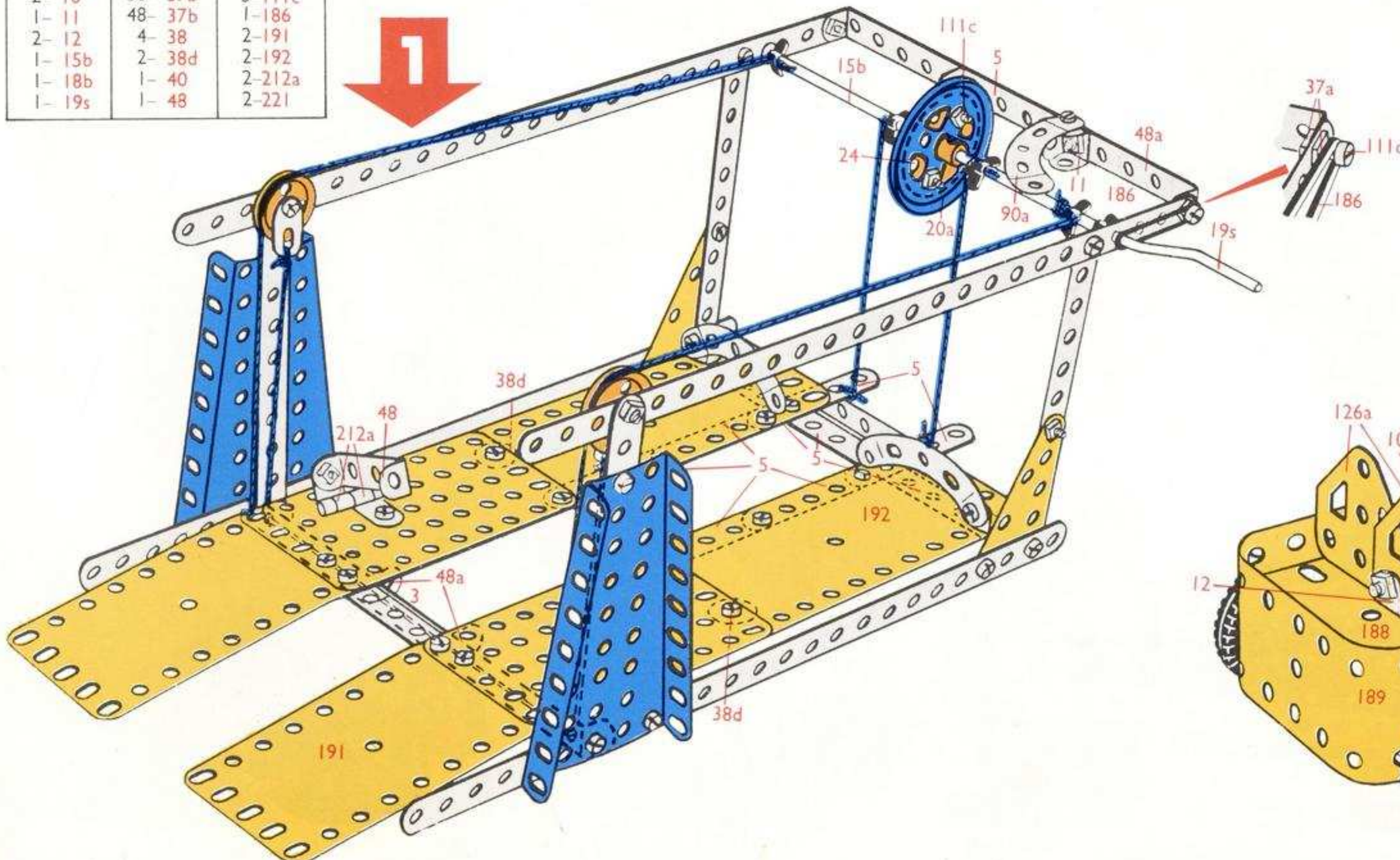

2- 2	4- 22	2- 125
2- 10	1- 24	2- 126
1- 11	2- 35	2- 126a
2- 12	18- 37a	4- 142c
2- 12c	18- 37b	2- 188
2- 16	10- 38	2- 189
1- 17	1- 52	1- 193

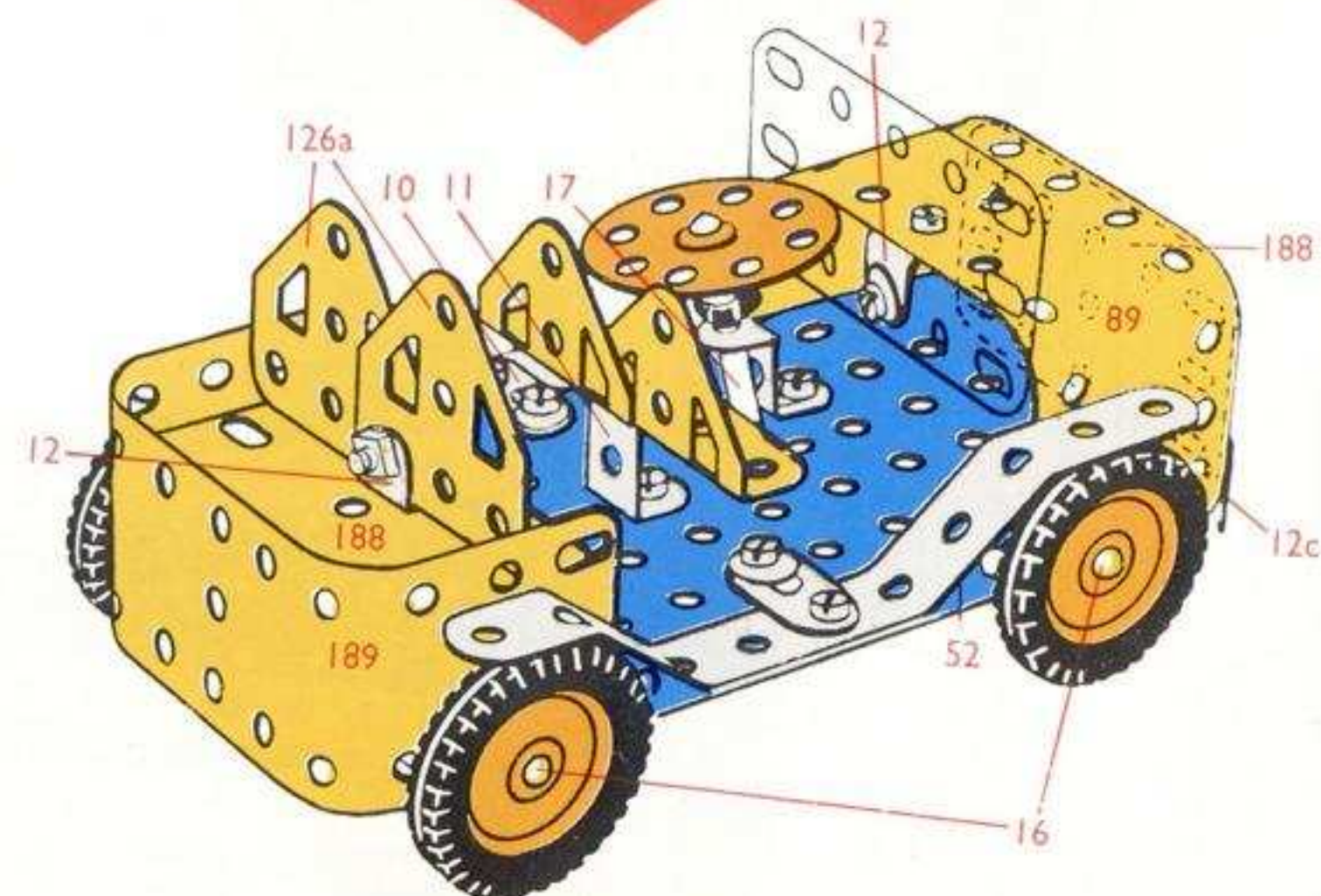

5.6.

Jumbo Crane
 Jumbokraan
 Grue géante
 Gru Jumbo
 Jumbo Kran
 Tung lyftkran
 Grúa gigante
 Guindaste gigante
 Jumbo-kran

2- 1	1- 20a	6- 48a	1- 176
8- 2	4- 22	1- 51	4- 187
2- 3	1- 23	1- 52	2- 188
9- 5	1- 23a	2- 54	2- 189
2- 10	2- 24	1- 57c	1- 190
2- 11	2- 27f	2- 90a	2- 191
1- 11a	10- 35	2- 111	2- 194
4- 12	104- 37a	2- 111a	1- 200
2- 15b	88- 37b	1- 111c	1- 212
2- 16	15- 38	2- 126	2- 212a
2- 17	2- 38d	2- 126a	2- 214
2- 18a	1- 40	1- 142c	4- 221
1- 19s	2- 48	2- 155	

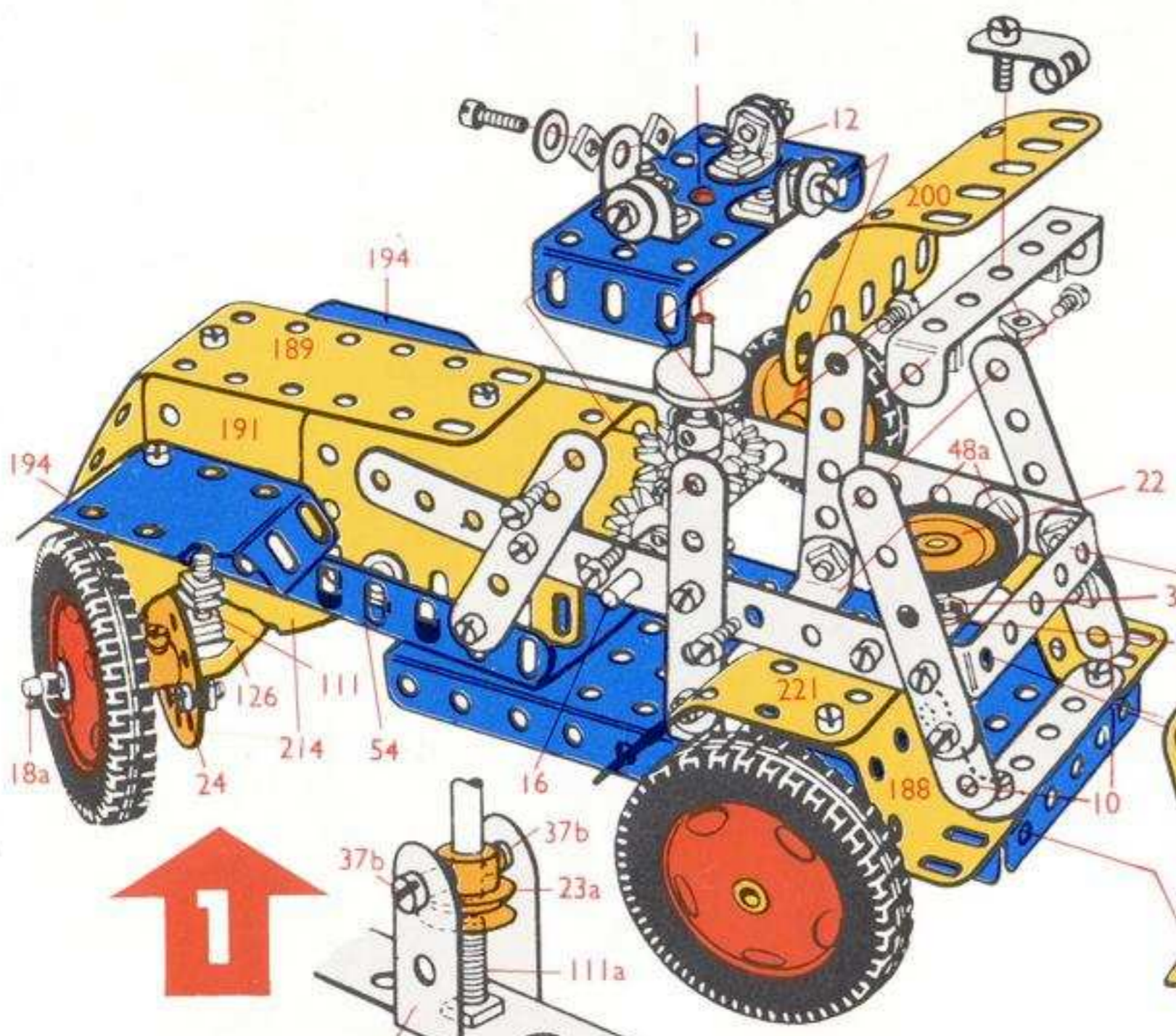

2- 2	1- 51
1- 3	1- 52
8- 5	1- 54
2- 10	2- 90a
4- 12	2- 111
1- 15b	2- 126
1- 16	1- 142c
2- 17	1- 155
2- 18a	4- 187
2- 22	2- 188
2- 24	1- 189
2- 27f	1- 190
5- 35	2- 191
72- 37a	2- 194
62- 37b	1- 200
7- 38	1- 212a
2- 38d	2- 214
1- 48	2- 221
4- 48a	

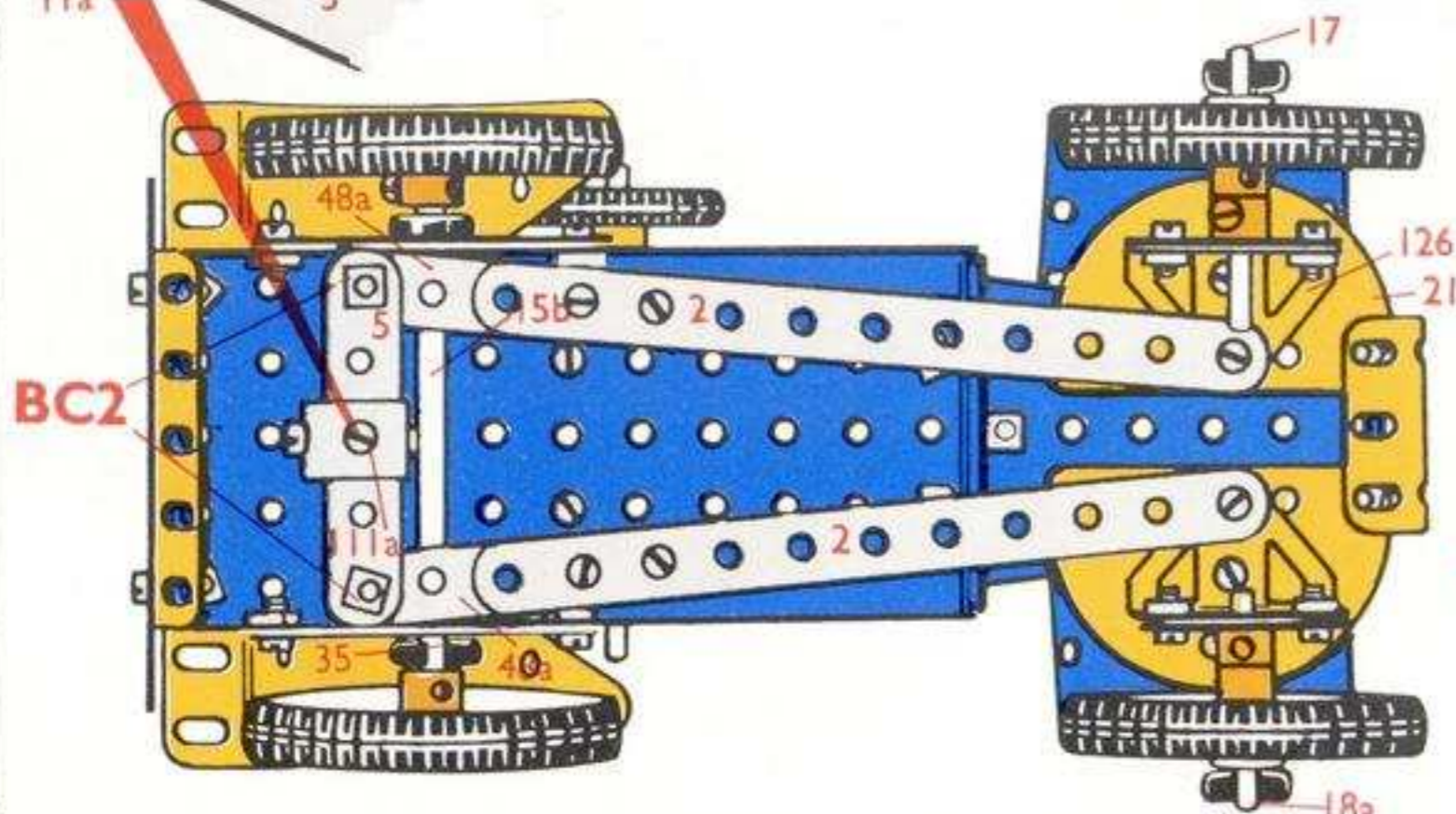

2- 2
1- 5
1- 11a
1- 23a
13- 37a
10- 37b
2- 48a
1- 111a

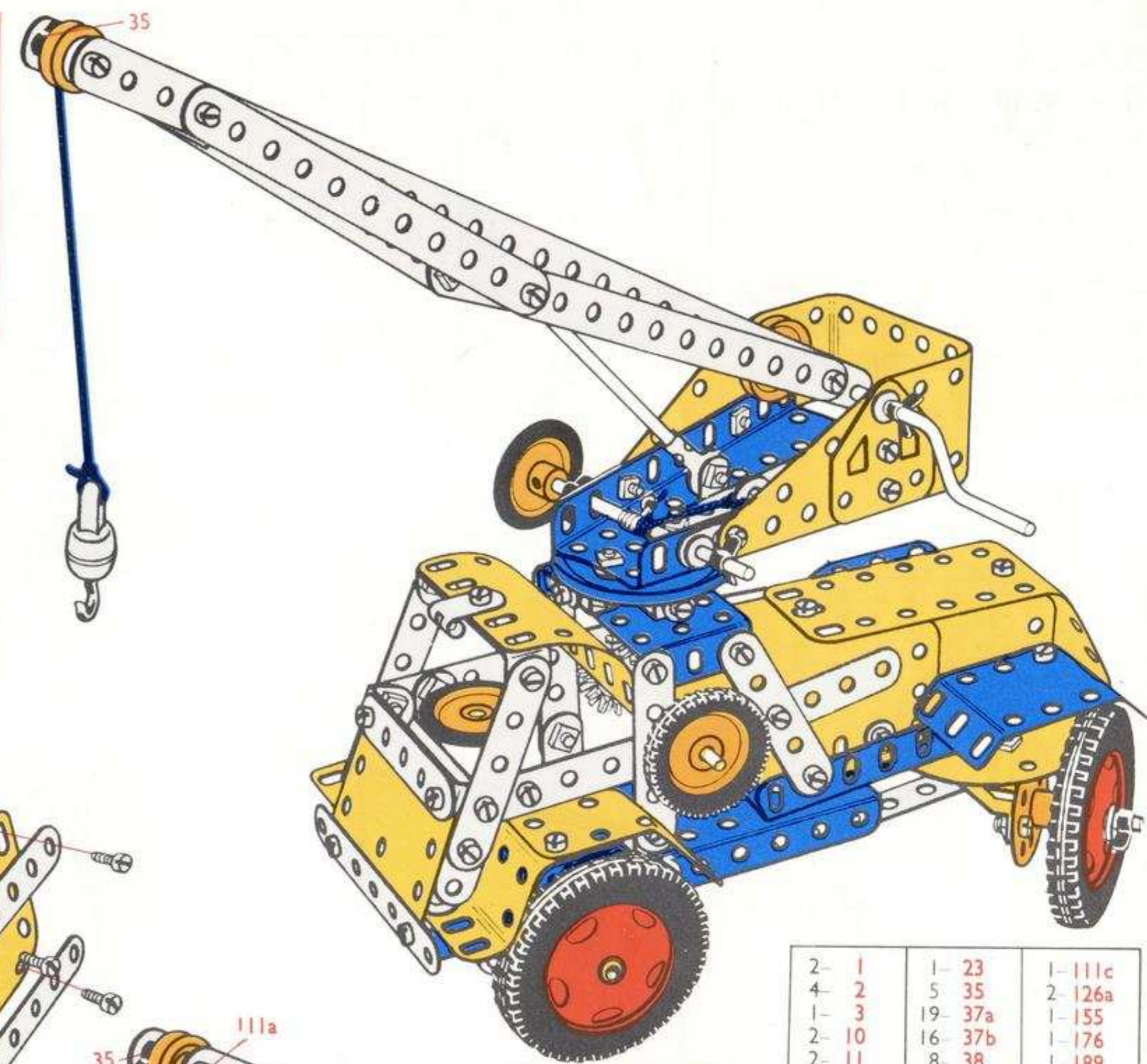

2- 1	1- 23	1- 111c
4- 2	5- 35	2- 126a
1- 3	19- 37a	1- 155
2- 10	16- 37b	1- 176
2- 11	8- 38	1- 189
1- 15b	1- 40	1- 212
1- 16	1- 48	1- 212a
1- 19s	1- 54	2- 221
1- 20a	1- 57c	
2- 22	1- 111a	

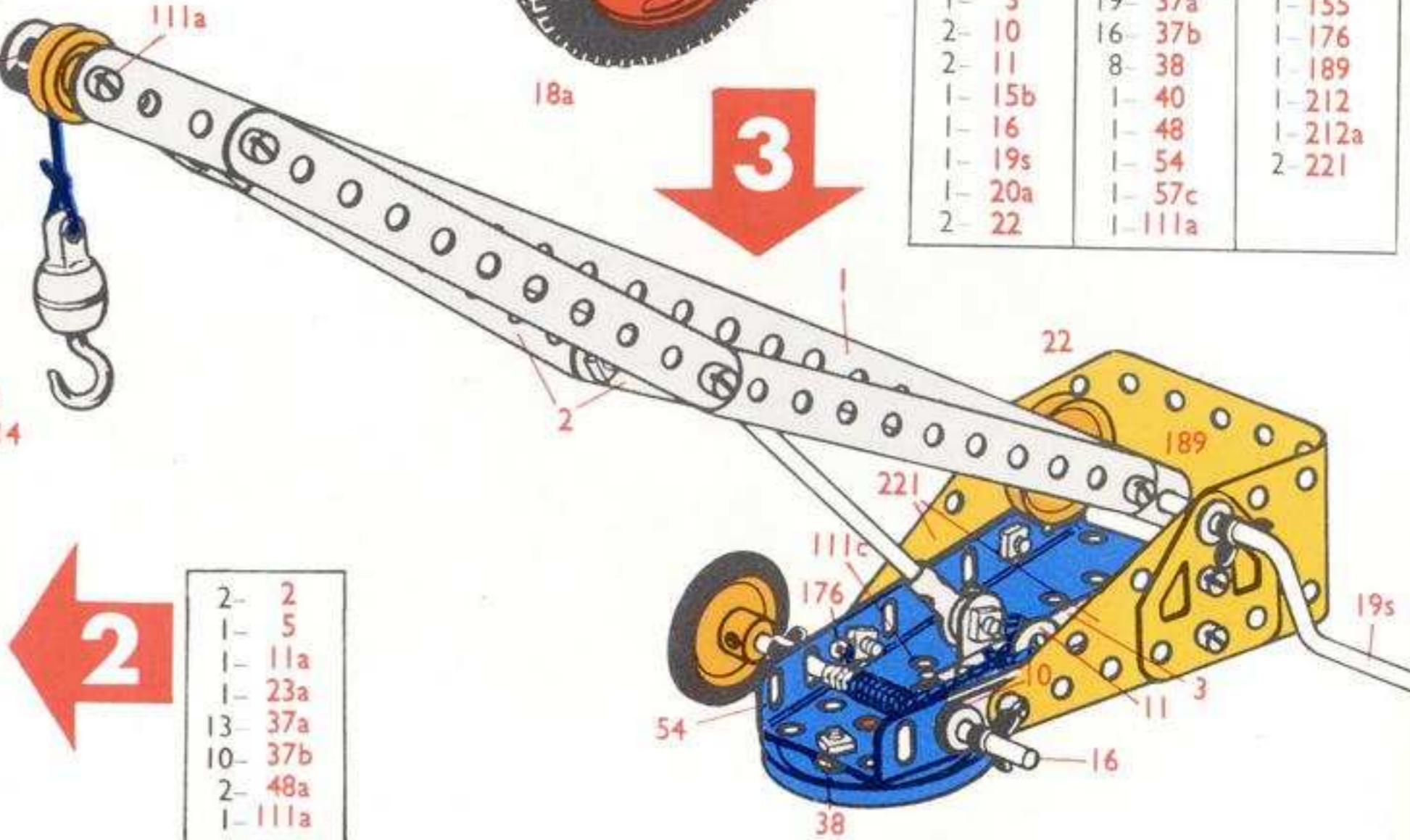

5.7.
Loading Shovel
Lepelschop
Pelle de chargement
Motopala
Schaufellader
Skoplastare
Pala cargadora
Pá de cargar
Lasteskuffe

8- 2	1- 19s	1- 52	3- 190
2- 3	4- 22	2- 53a	2- 191
9- 5	2- 24	2- 54	1- 199
1- 10	2- 27f	4- 90a	1- 200
2- 11	16- 35	4- 111c	1- 212
1- 11a	95- 37a	2- 125	2- 212a
10- 12	93- 37b	2- 126	1- 213
4- 12c	12- 38	2- 126a	2- 214
2- 15b	2- 38d	1- 155	4- 221
4- 16	1- 40	1- 176	
2- 17	1- 48	1- 186	
2- 18a	6- 48a	4- 187	
1- 18b	1- 51	1- 188	

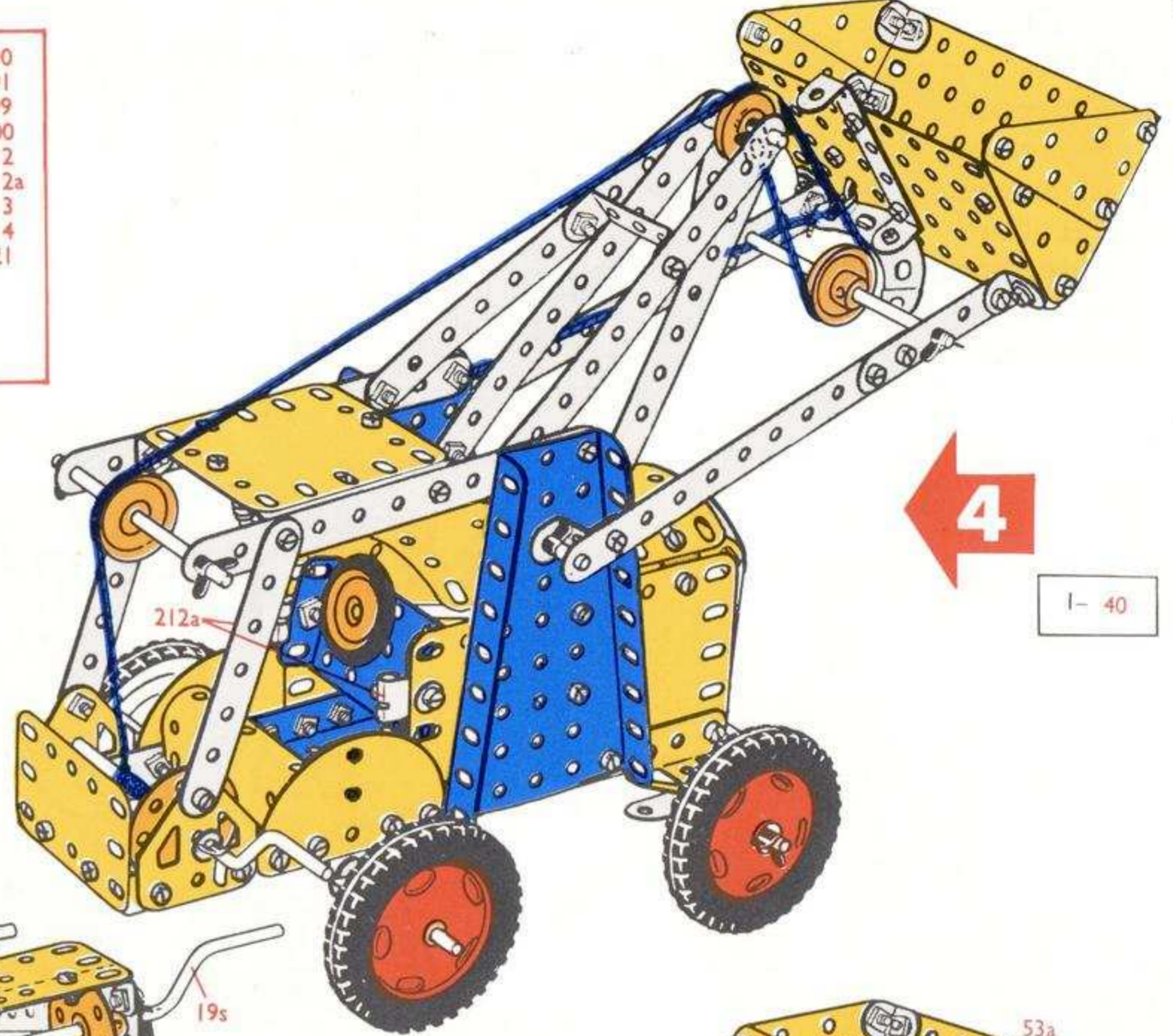

1- 40

2- 2	2- 22	1- 51	1- 188
2- 3	1- 24	1- 52	3- 190
2- 5	2- 27f	2- 54	2- 191
1- 11a	3- 35	2- 90a	1- 200
4- 12c	55- 37a	2- 111c	1- 212
2- 16	53- 37b	2- 126	2- 212a
1- 18a	4- 38	2- 126a	2- 214
1- 18b	2- 38d	1- 155	
1- 19s	4- 48a	1- 176	

5- 5	9- 37b
2- 11	4- 38
2- 16	1- 48a
2- 17	1- 111c
1- 24	4- 187
7- 35	1- 199
10- 37a	1- 213

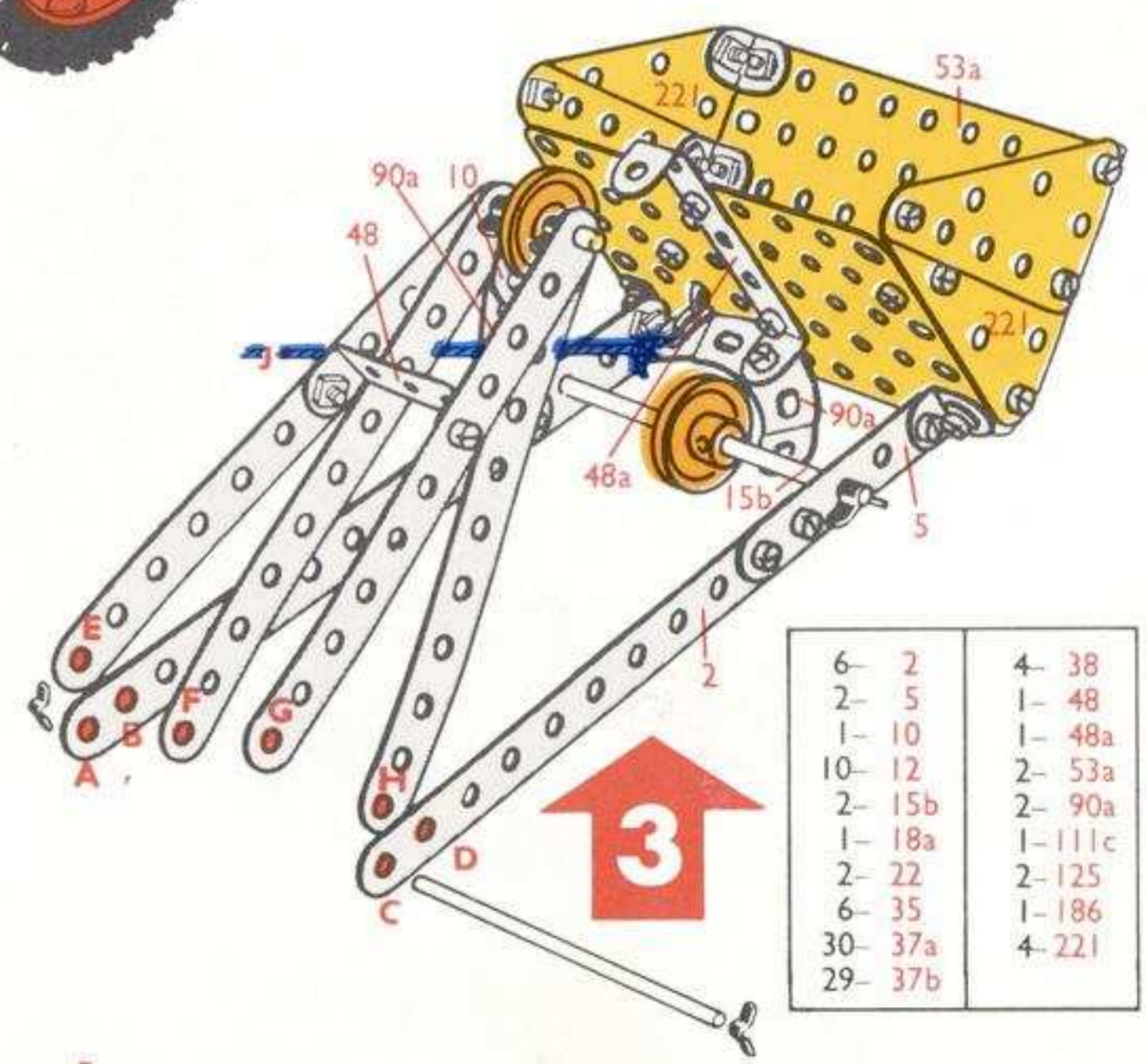
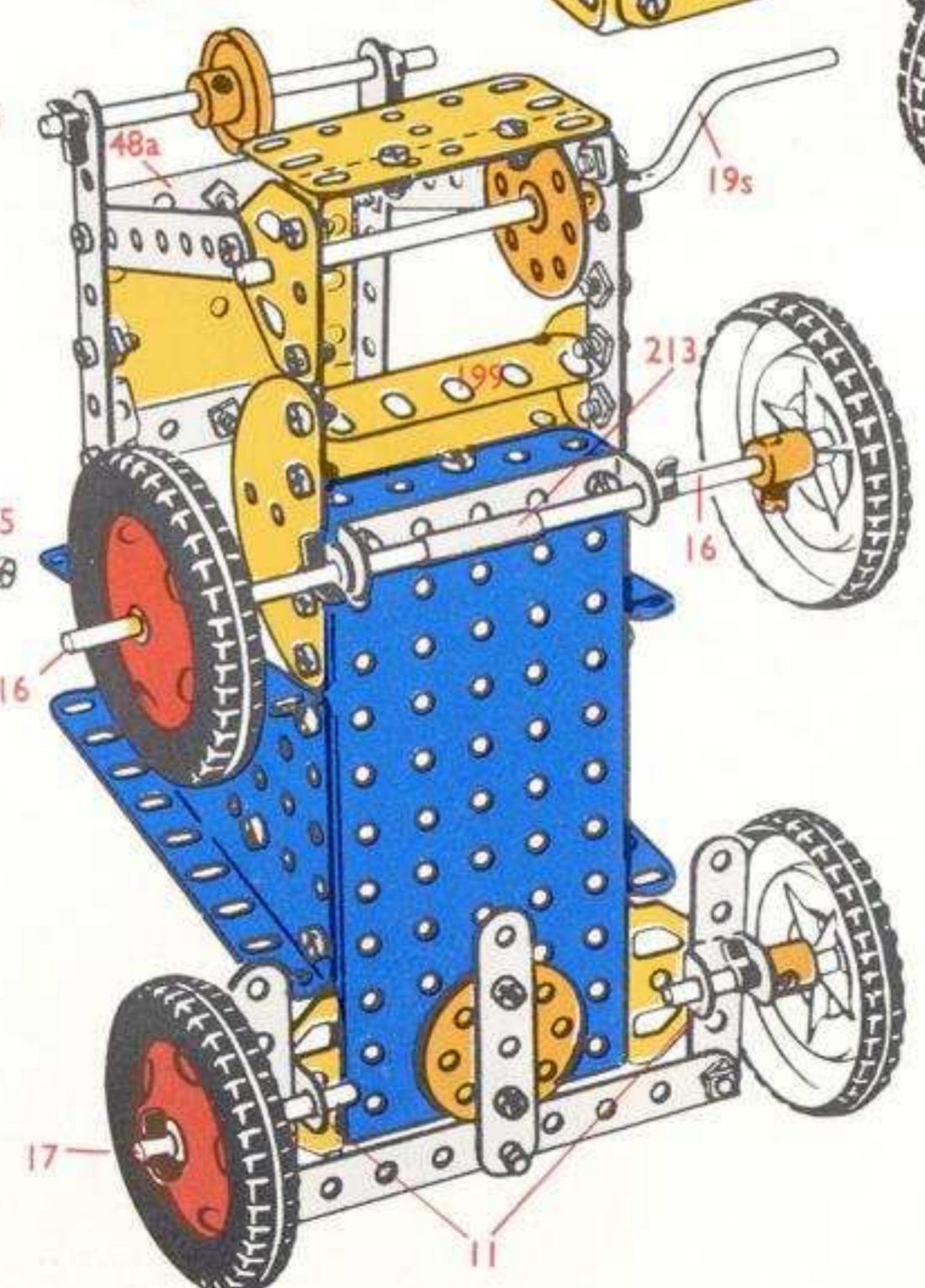
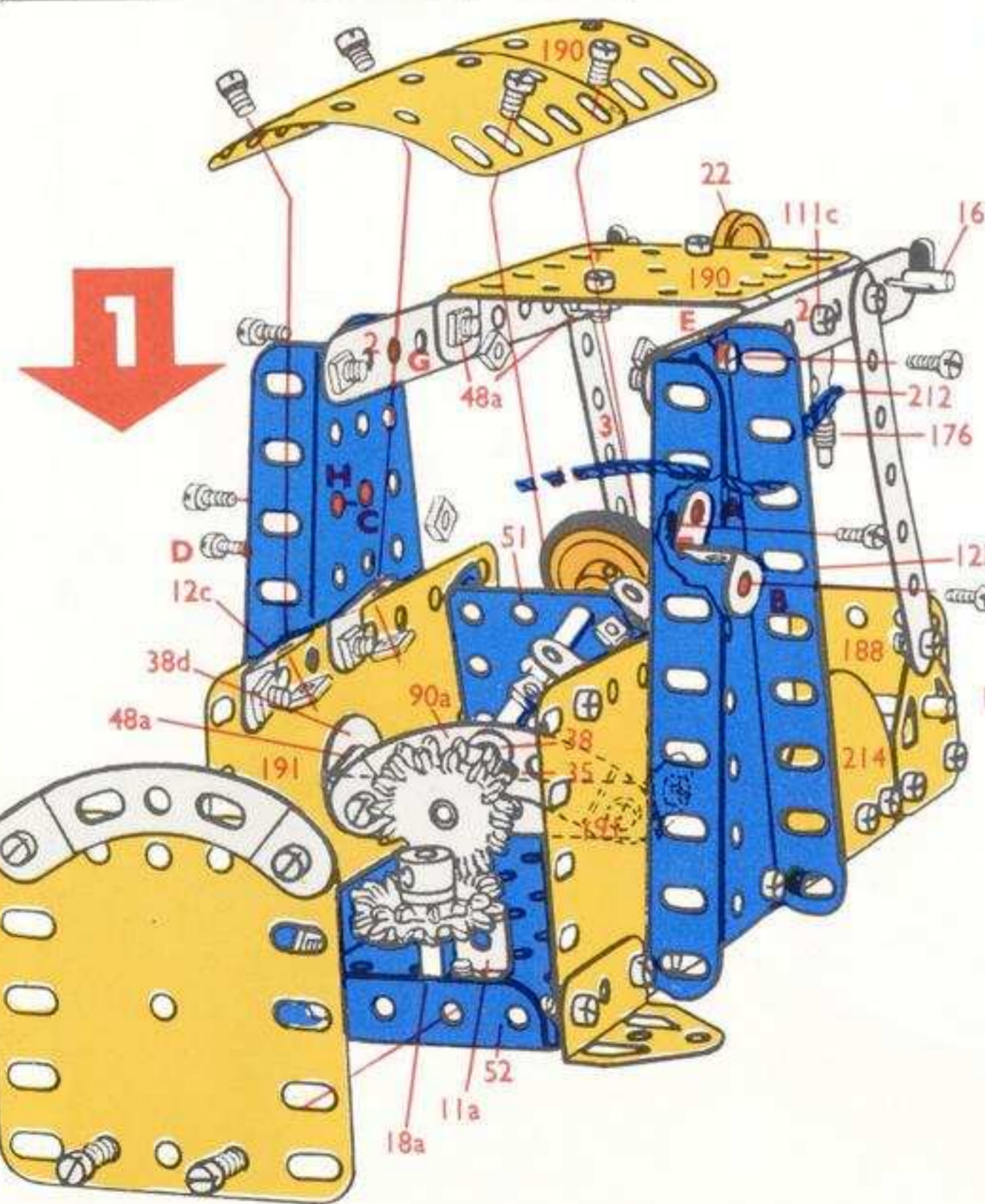

6- 2	4- 38
2- 5	1- 48
1- 10	1- 48a
10- 12	2- 53a
2- 15b	2- 90a
1- 18a	1- 111c
2- 22	2- 125
6- 35	1- 186
30- 37a	4- 221
29- 37b	

5.8.

Helicopter
 Hefschroefvliegtuig
 Hélicoptère
 Elicottero
 Hubschrauber
 Helikopter
 Helicóptero

4- 1	4- 22	1- 51	1-191
8- 2	2- 22a	2- 54	2-192
2- 3	1- 23	3- 90a	2-193
9- 5	2- 24	2-111	1-193a
1-10	2- 27f	2-125	1-199
1-11a	1- 35	2-126	1-200
5-12	94-37a	2-126a	1-213
4-12c	91-37b	2-142c	2-214
2-15b	11- 38	2-155	4-215
1- 16	1- 38d	1-186	4-221
1-18a	1- 40	2-188	
2-19b	1- 48	2-189	
1-20a	4- 48a	3-190	

1- 1	1-20a	1- 48	1-186
1- 2	3- 22	4- 48a	2-188
2- 3	2- 22a	1- 51	3-190
4- 5	1- 23	2- 54	2-193
1-11a	2- 27f	3- 90a	1-193a
3-12	1- 35	1-111	1-200
4-12c	54-37a	2-125	1-213
2-15b	52-37b	2-126	2-214
1- 16	7- 38	2-126a	3-215
1-18a	1- 38d	2-142c	4-221
2-19b	1- 40	2-155	

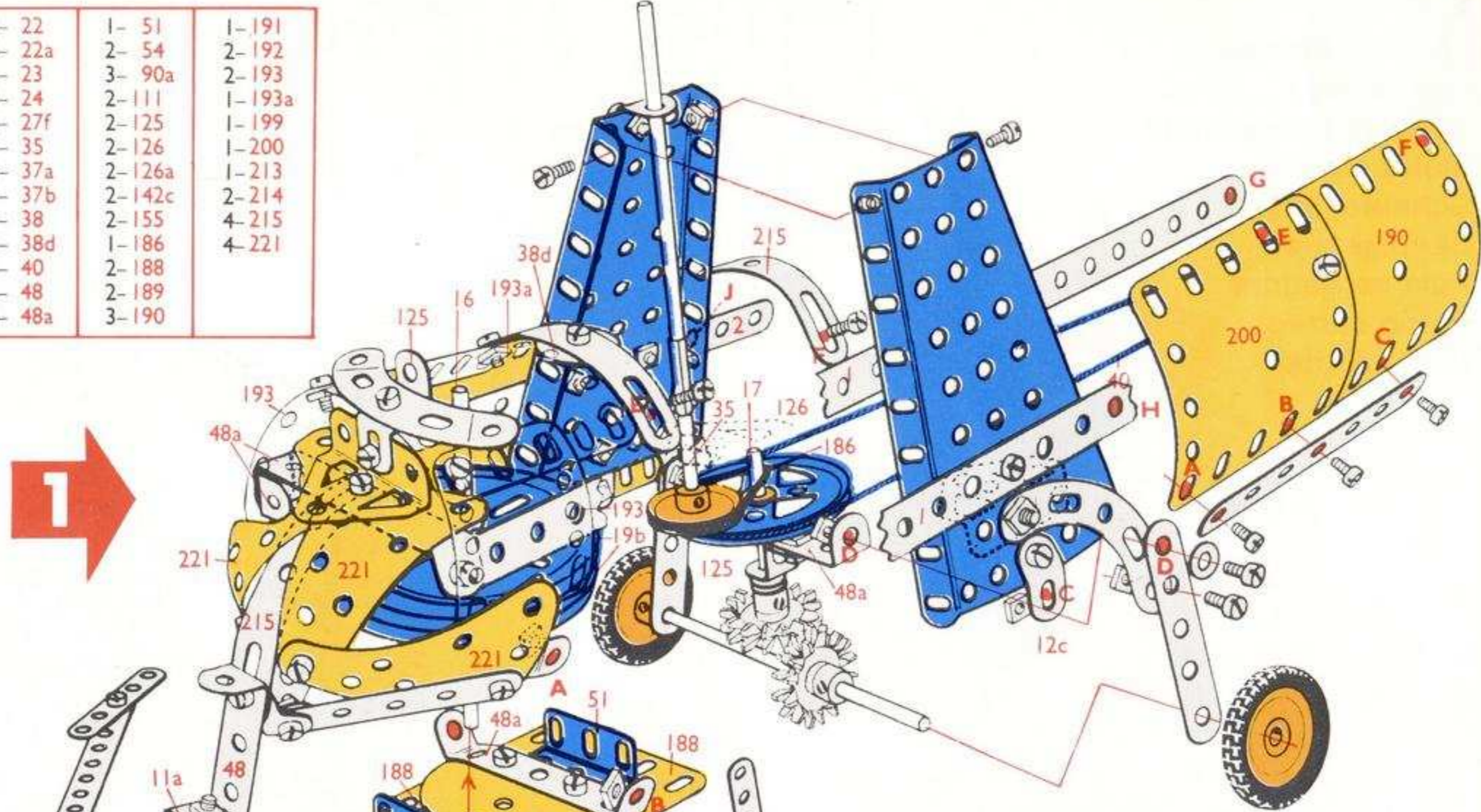

3- 1	4- 38
1- 2	1-111
2- 5	2-189
1-10	1-191
2-12	2-192
1-22	1-199
25-37a	1-215
24-37b	

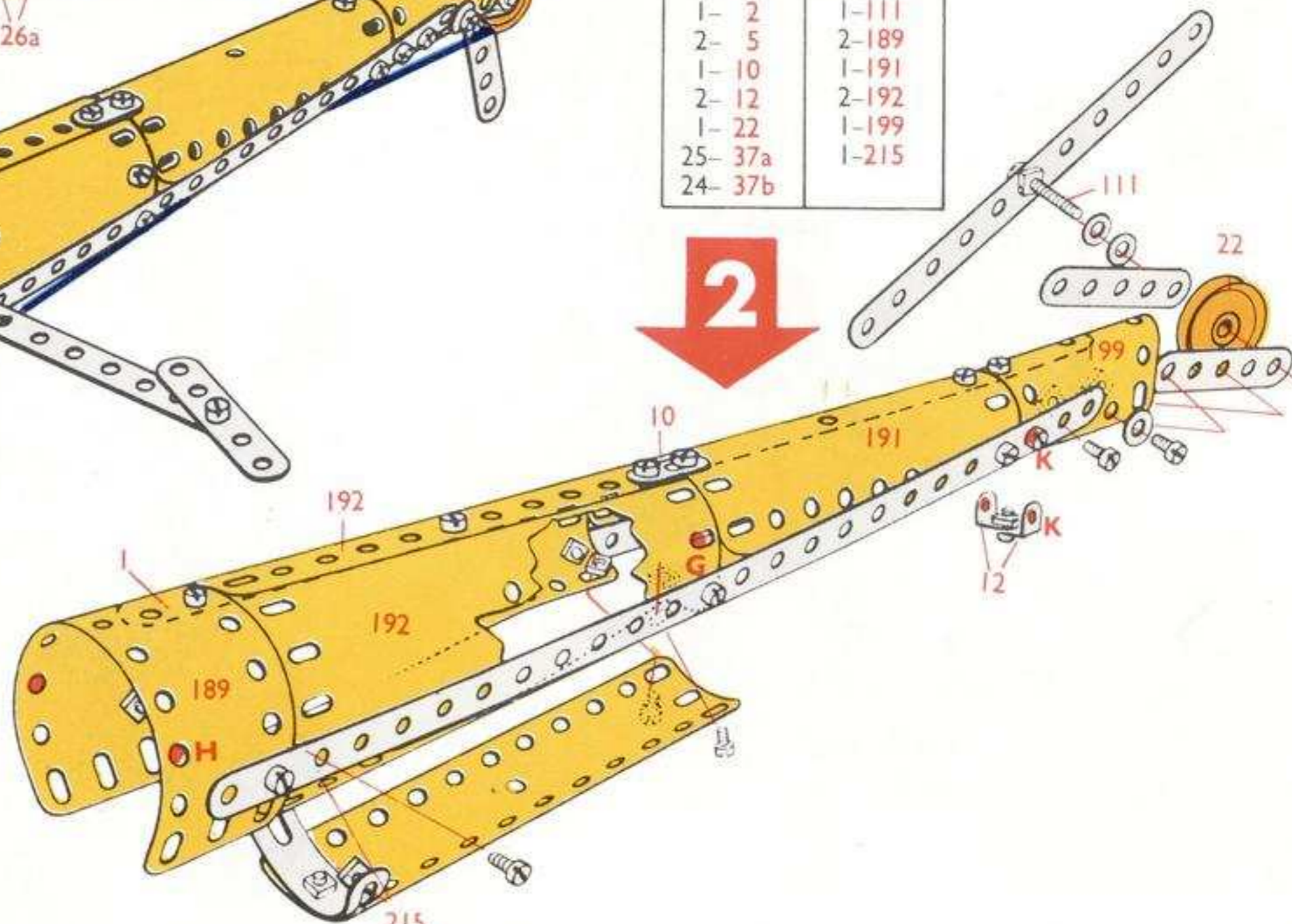

6- 2
3- 5
2-24
15-37a
15-37b

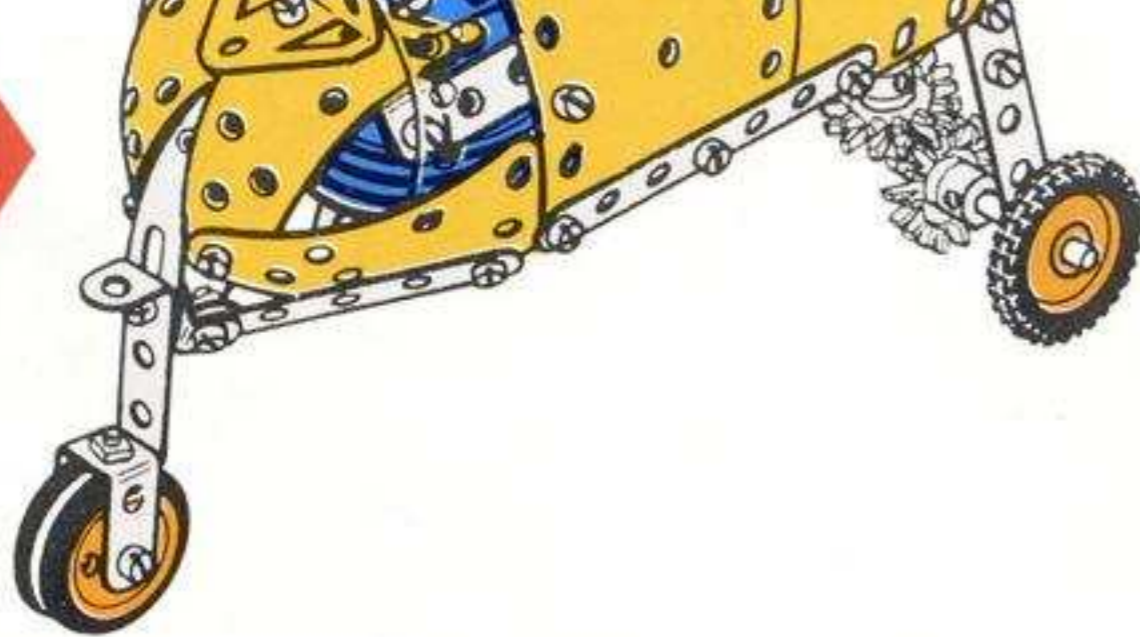

5.9.

Construction Crane with Grab
 Constructiekraan met grijper
 Grue de construction avec benne preneuse
 Gru per cantiere con benna
 Baukran mit Greifer
 Byggnadskran med gripanordning
 Grúa para obras, con bivalva
 Guindaste de construção com garras
 Kran med grabb

4- 1	1- 19s	2- 38d	2-126a
8- 2	1- 20a	1- 40	1-176
2- 3	4- 22	2- 48	1-186a
9- 5	2- 22a	6- 48a	*1-186b
4- 10	1- 23	1- 51	2-187
2- 11	*1- 23a	1- 52	2-188
1- 11a	1- 23a	2- 53a	2-189
10- 12	2- 24	2- 54	1-190
1- 12c	2- 27f	4- 90a	1-200
2- 15b	16- 35	2-111	2-212a
4- 16	103- 37a	2-111a	1-213
2- 17	93- 37b	2-111c	2-221
2- 19b	14- 38	2-126	*1-M5

* Non inclus dans la boîte
 * Not included in set



6- 2
2- 5
2- 10
4- 12
1- 12c
2- 17
2- 22
1- 23
2- 35
25- 37a
23- 37b
1- 48
1- 48a
3- 90a
2- 111c
2- 126
1- 190
1- 200
2- 212a

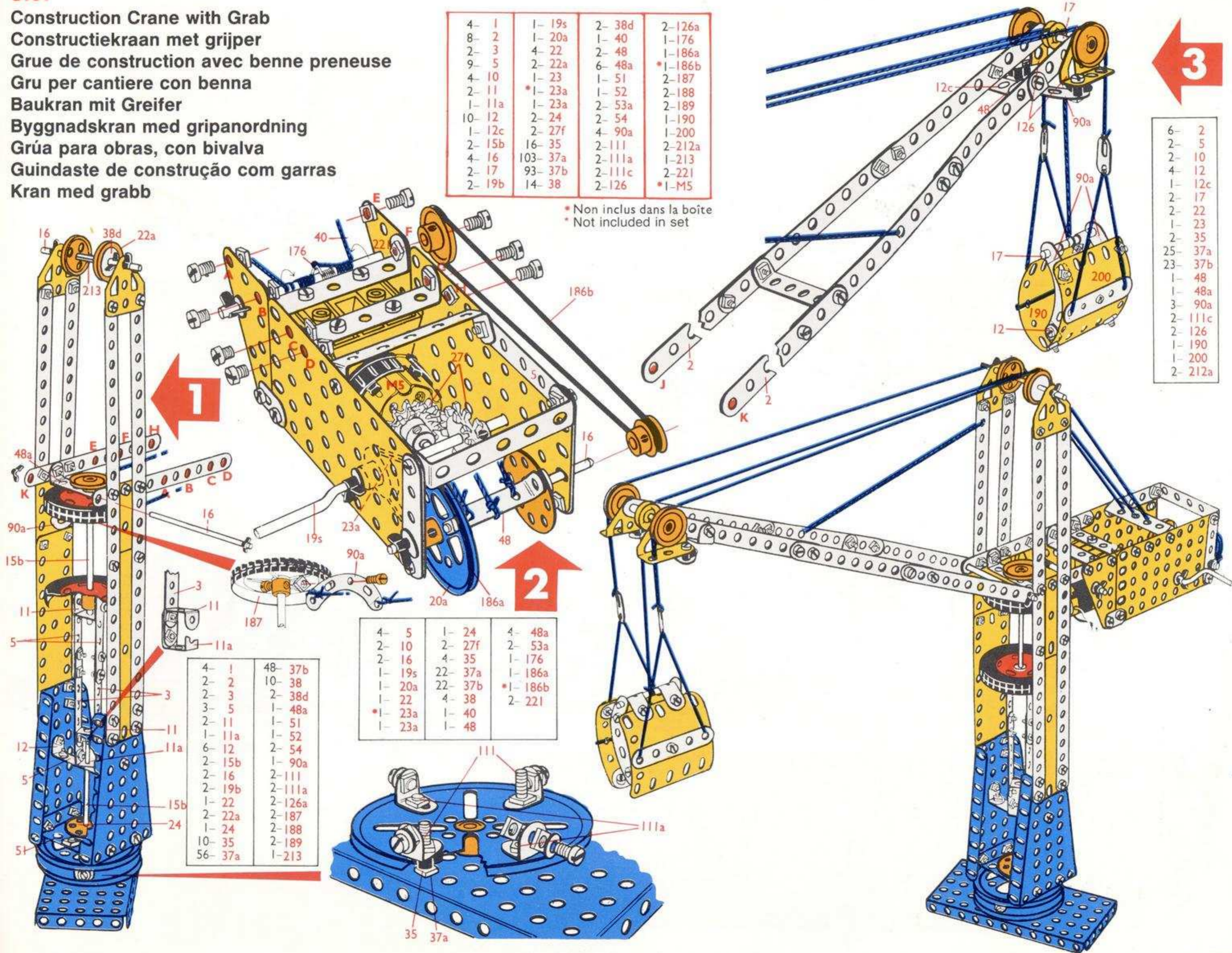

4- 1	48- 37b
2- 2	10- 38
2- 3	2- 38d
3- 5	1- 48a
2- 11	1- 51
1- 11a	1- 52
6- 12	2- 54
2- 15b	1- 90a
2- 16	2-111
2- 19b	2-111a
1- 22	2-126a
2- 22a	2-187
1- 24	2-188
10- 35	2-189
56- 37a	1-213

4- 5	1- 24	4- 48a
2- 10	2- 27f	2- 53a
2- 16	4- 35	1- 176
1- 19s	22- 37a	1- 186a
1- 22	22- 37b	*1- 186b
*1- 23a	4- 38	2- 221
1- 23a	1- 40	
	1- 48	

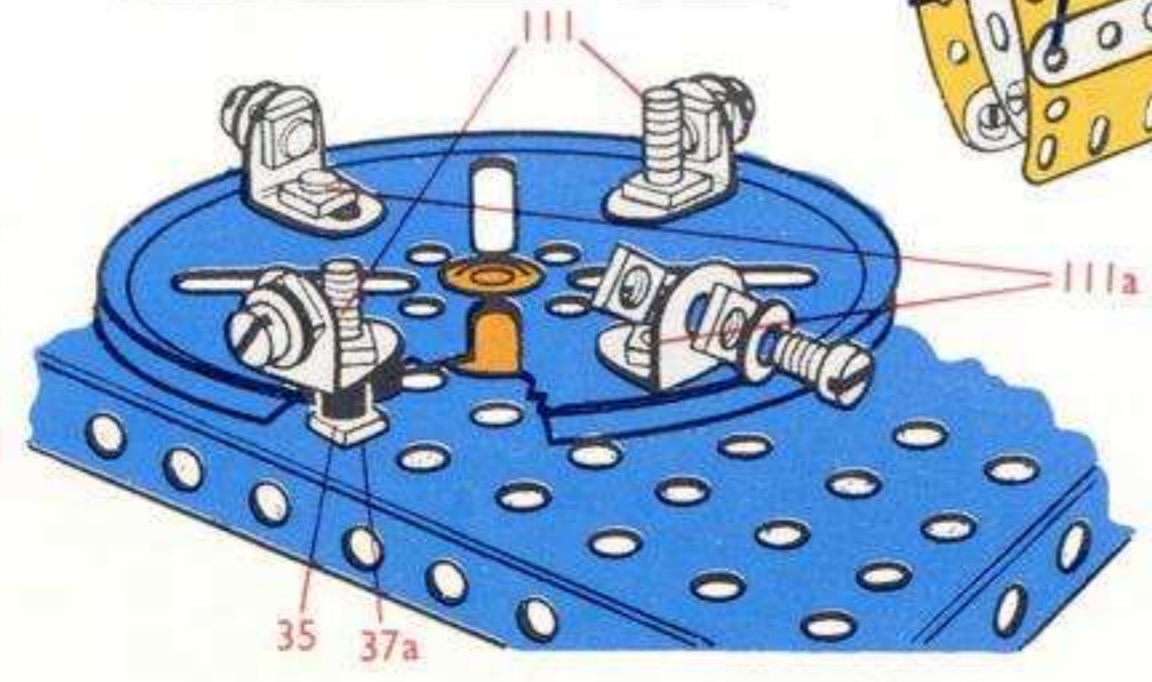

5.10.

Diesel Electric Locomotive
Diesel-elektrische locomotief
Locomotive électrique Diesel
Locomotore diesel/elettrico
Elektro-Diesel-Lokomotive
Dieselektriskt lok
Locomotoras diesel eléctrica
Locomotiva Diesel eléctrica
Diesel-lokomotiv

2- 1	32- 37b
2- 2	1- 38
4- 5	2- 38d
4- 10	2- 48a
1- 11a	1- 51
1- 12	1- 52
1- 16	3- 11c
* 1- 23a	2- 126
1- 24	2- 126a
2- 35	1- 212
40- 37a	

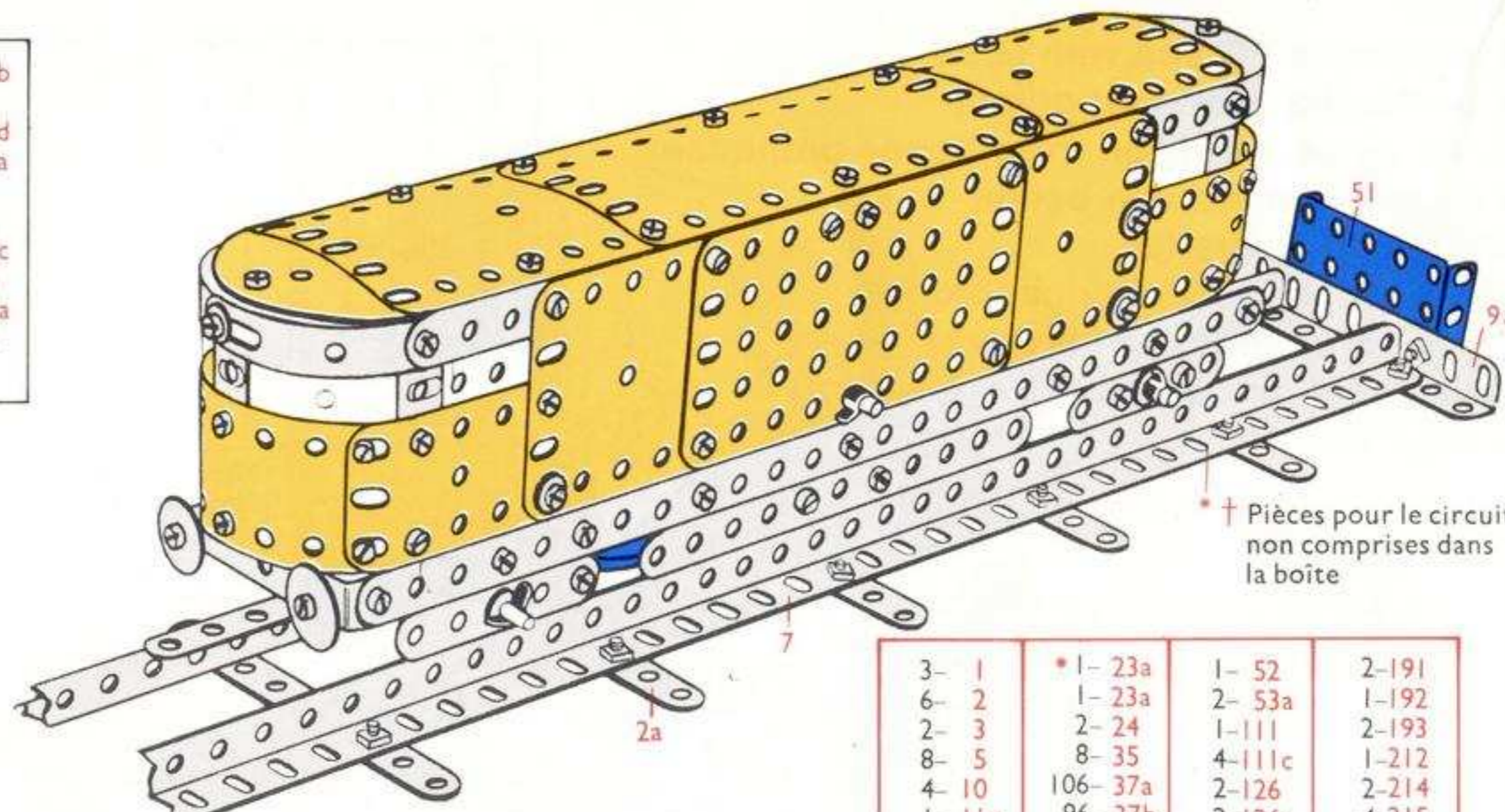

3- 1	* 1- 23a	1- 52	2- 191
6- 2	1- 23a	2- 53a	1- 192
2- 3	2- 24	1- 111	2- 193
8- 5	8- 35	4- 111c	1- 212
4- 10	106- 37a	2- 126	2- 214
1- 11a	96- 37b	2- 126a	4- 215
7- 12	13- 38	1- 186	* 1- M5
4- 16	2- 38d	2- 188	
1- 20a	6- 48a	2- 189	
4- 22	1- 51	4- 190	

* Non inclus dans la boîte
 * Not included in set

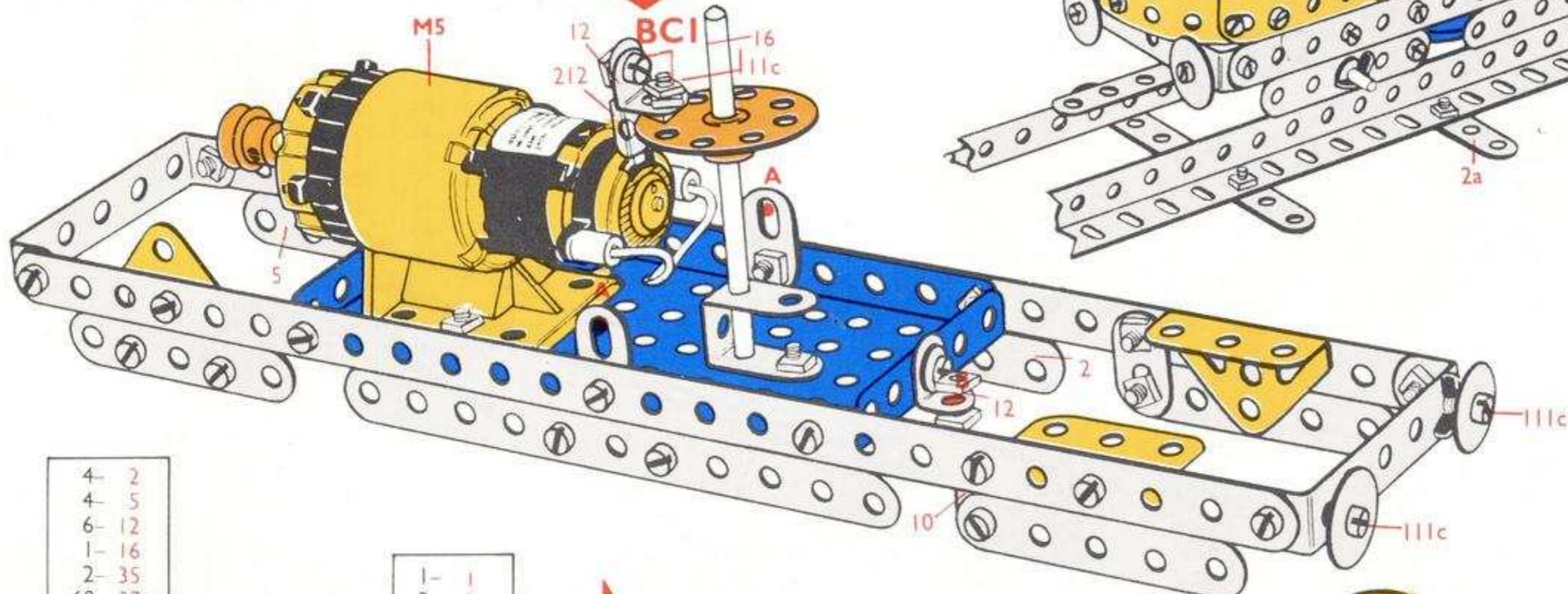

4- 2
4- 5
6- 12
1- 16
2- 35
60- 37a
60- 37b
8- 38
4- 48a
2- 53a
2- 188
2- 189
4- 190
2- 191
1- 192
2- 193
2- 214
4- 215

1- 1
2- 3
2- 16
1- 20a
4- 22
1- 23a
1- 24
4- 35
6- 37a
3- 37b
4- 38
1- 111
1- 111c
1- 186

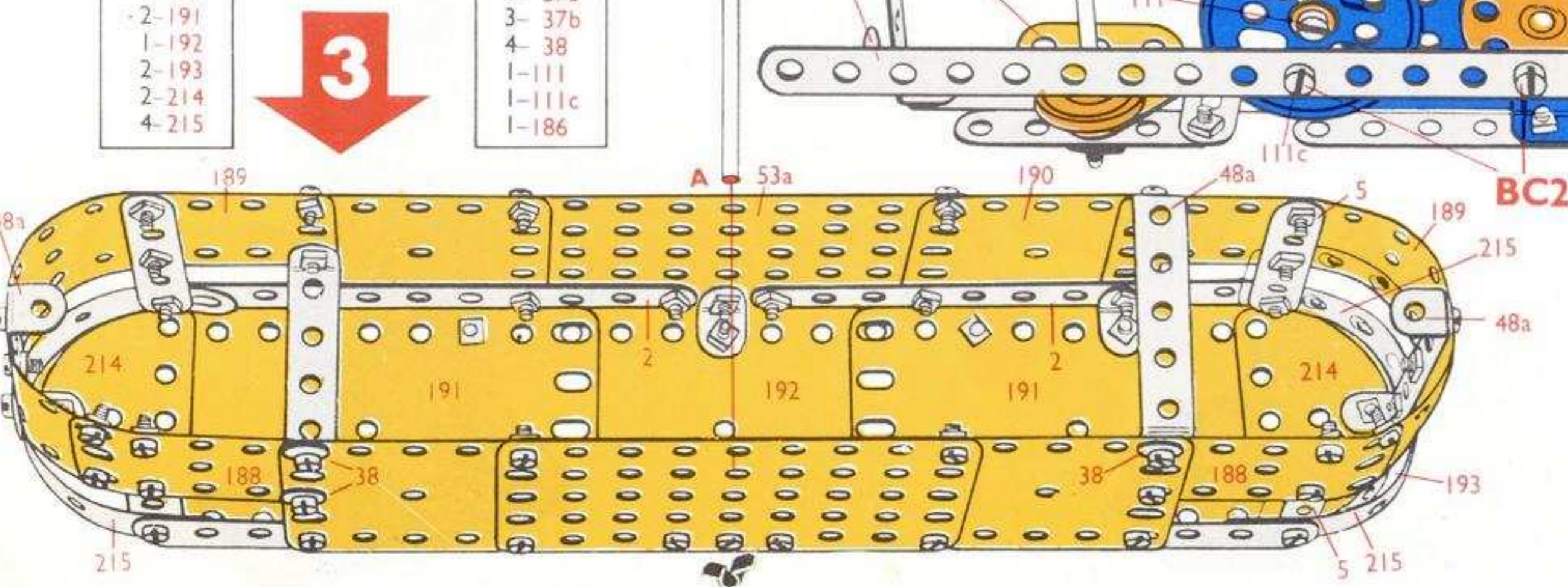
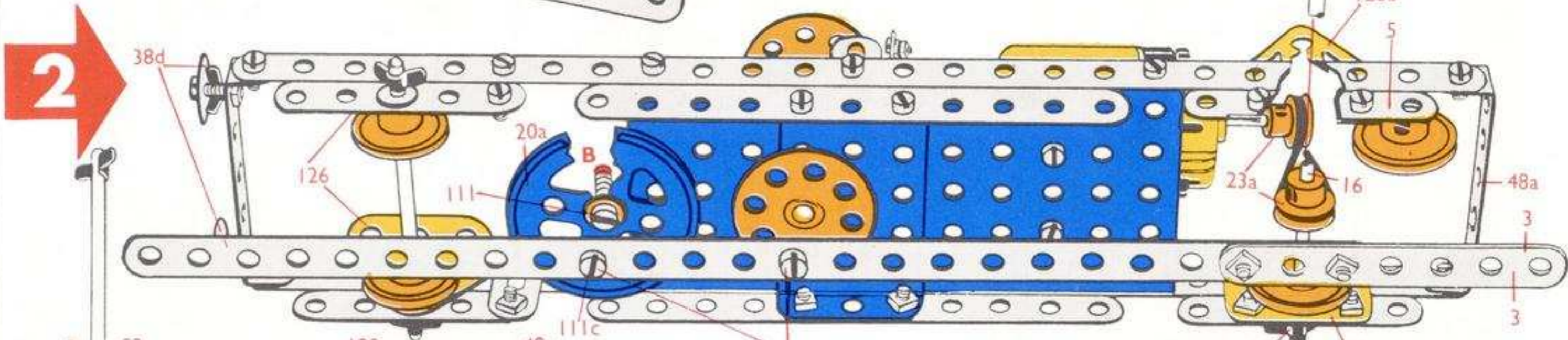

Pièces pour circuit de 62 cm non comprises dans la boîte
 Parts not included in box for the circuit 62 cm

Pièces No	2a	7	9a	37a	37b	51
† Quantité		2	2	22	22	2

5.11.

Traction Engine
Tractiewagen
Moteur de traction
Motore di trazione
Zugmaschine
Lokomobil
Máquina de tracción
Motor de tracção

8- 2	4- 22	2- 48	*1-186a
2- 3	2- 22a	6- 48a	1-186a
8- 5	1- 23	1- 52	2-187
2- 11	*1- 23a	2- 53a	2-188
1- 11a	1- 23a	1-111	3-190
10- 12	2- 24	2-111c	2-191
4- 12c	2- 27f	2-125	2-192
2- 15b	7- 35	2-126	1-194a
4- 16	97- 37a	2-126a	1-199
2- 17	85- 37b	1-142c	1-212
1- 18a	10- 38	1- 155	*1-M4
2- 19b	2- 38d	1- 176	
1- 20a	1- 40	1-186	

* Non inclus dans la boîte
 * Not included in set

2- 5
2- 12c
1- 15b
2- 17
1- 18a
1- 20a
2- 22
*1- 23a
2- 24
3- 35
13- 37a
9- 37b
2- 48a
1-111c
2-126
1-186
*1-186a
1-186a
1-212

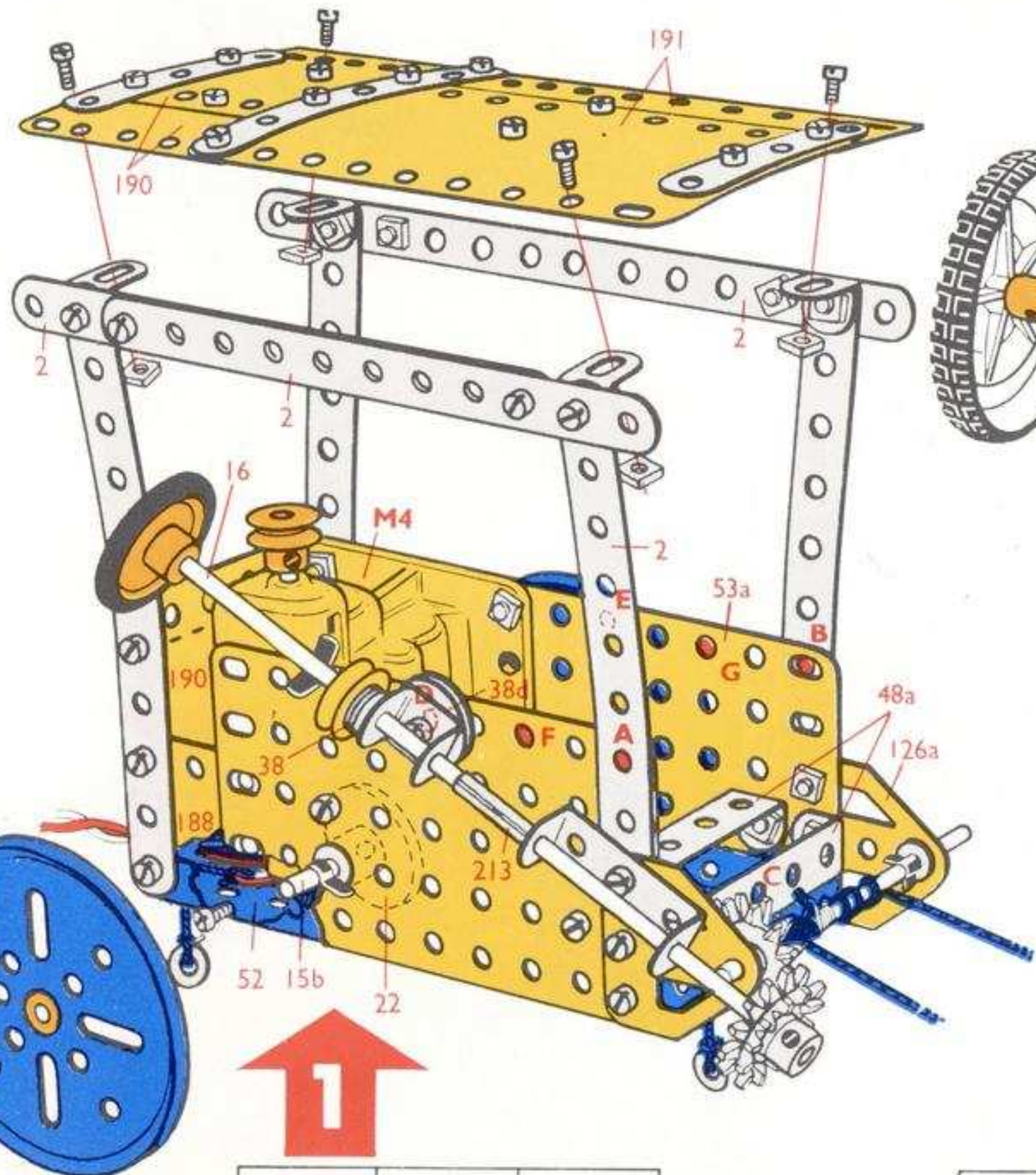

8- 2	1- 23a	1- 52
1- 3	2- 27f	2- 53a
3- 5	4- 35	2-126a
1- 11	52- 37a	1-155
6- 12	52- 37b	1-176
1- 15b	10- 38	2-188
3- 16	2- 38d	3-190
2- 19b	1- 40	2-191
2- 22	1- 48	
1- 23	2- 48a	

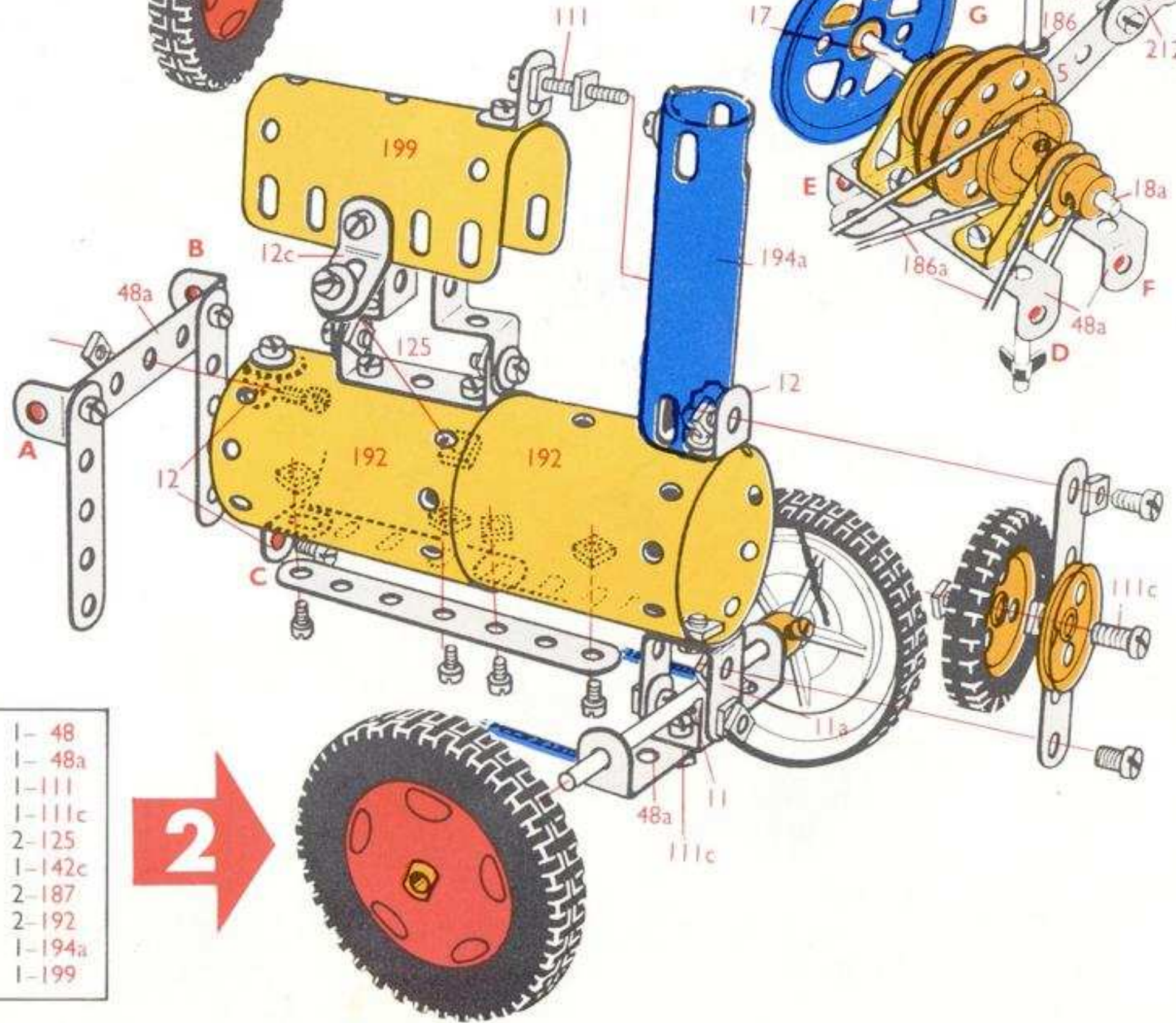

1- 3	1- 48
3- 5	1- 48a
1- 11	1-111
1- 11a	1-111c
4- 12	2-125
2- 12c	1-142c
1- 16	2-187
2- 22a	2-192
32- 37a	1-194a
24- 37b	1-199

5.12.

Dumper Truck
 Stortwagen
 Dumper
 Ribaltabile
 Kipplaster
 Tipptruck
 Camión volquete
 Carrinho basculante
 Dumperbil

2- 2	1- 20a	6- 48a	*1- 186b
2- 3	4- 22	1- 51	2- 187
9- 5	2- 22a	2- 53a	2- 188
4- 10	1- 23	2- 54	2- 189
2- 11	*1- 23a	4- 90a	2- 191
1- 11a	1- 23a	2- 111	1- 192
10- 12	2- 24	5- 111c	1- 212
2- 15b	15- 35	2- 125	2- 212a
4- 16	91- 37a	2- 126	2- 214
1- 17	79- 37b	2- 126a	2- 221
1- 18a	14- 38	2- 142c	*1- M4
1- 18b	2- 48	1- 155	

* Non inclus dans la boîte
 * Not included in set

2- 3	25- 37a
4- 5	17- 37b
1- 10	2- 38
2- 11	1- 48
2- 12	2- 111
1- 17	2- 126
1- 18a	2- 142c
1- 18b	2- 212a
2- 22	1- 214
2- 35	

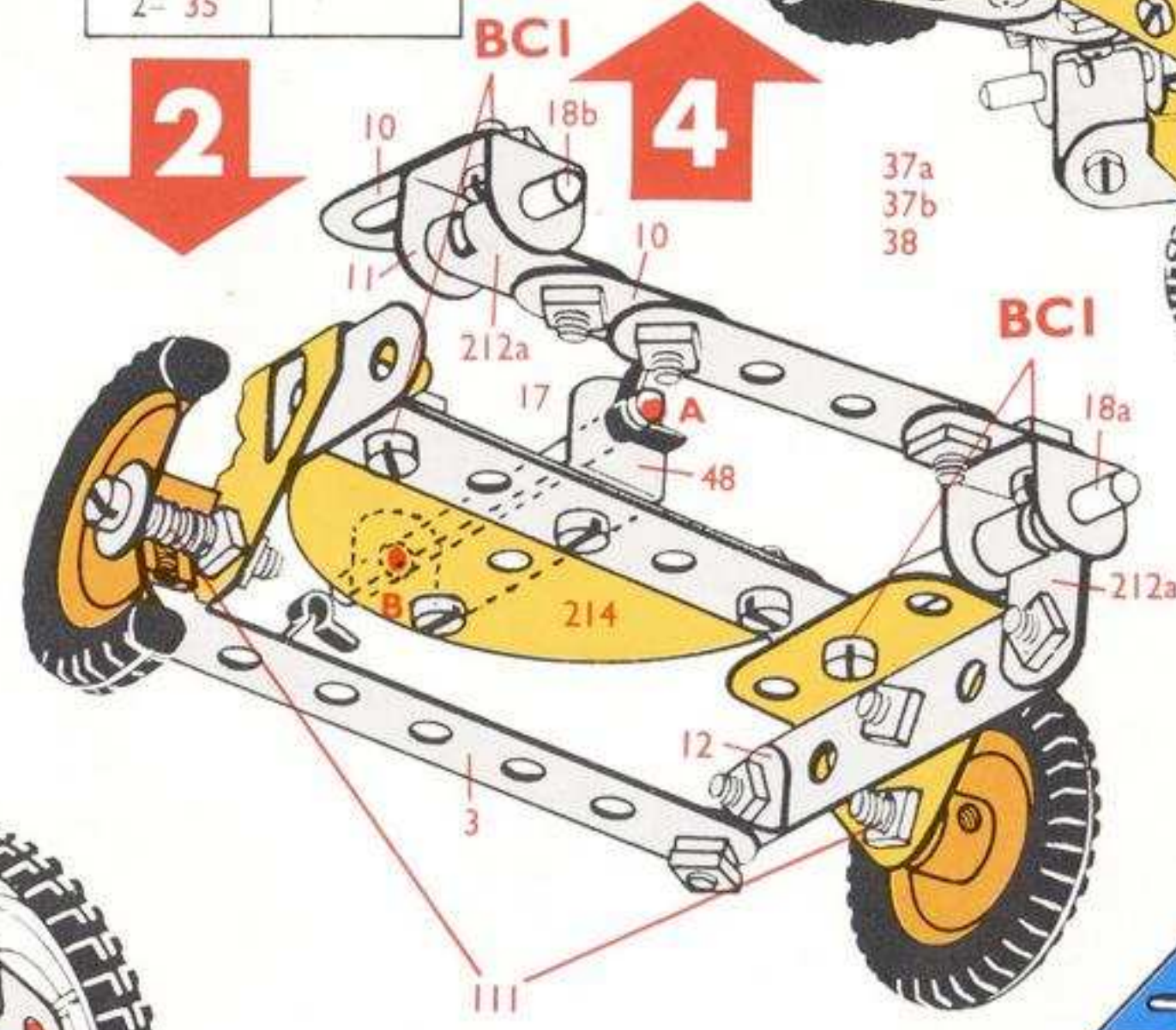
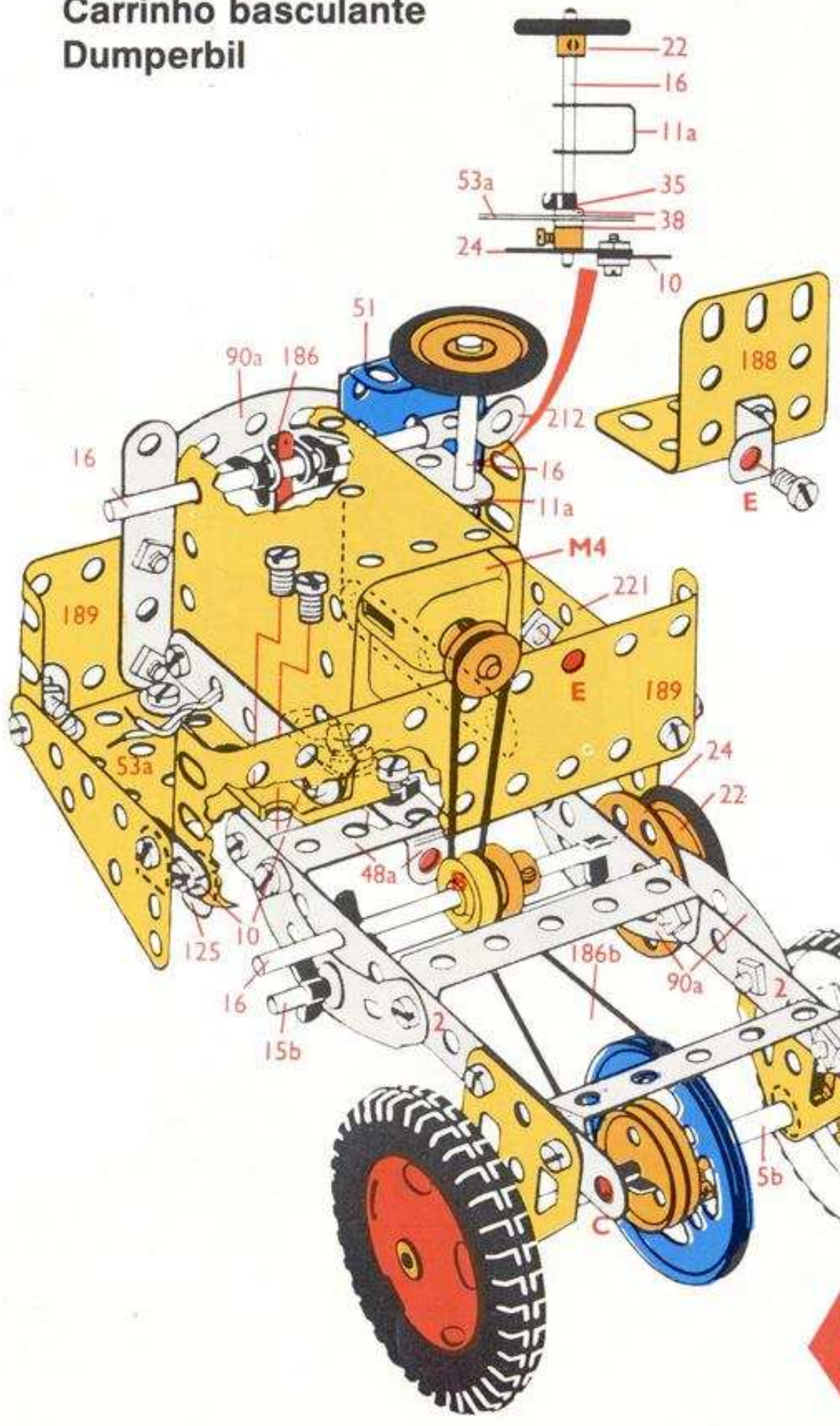
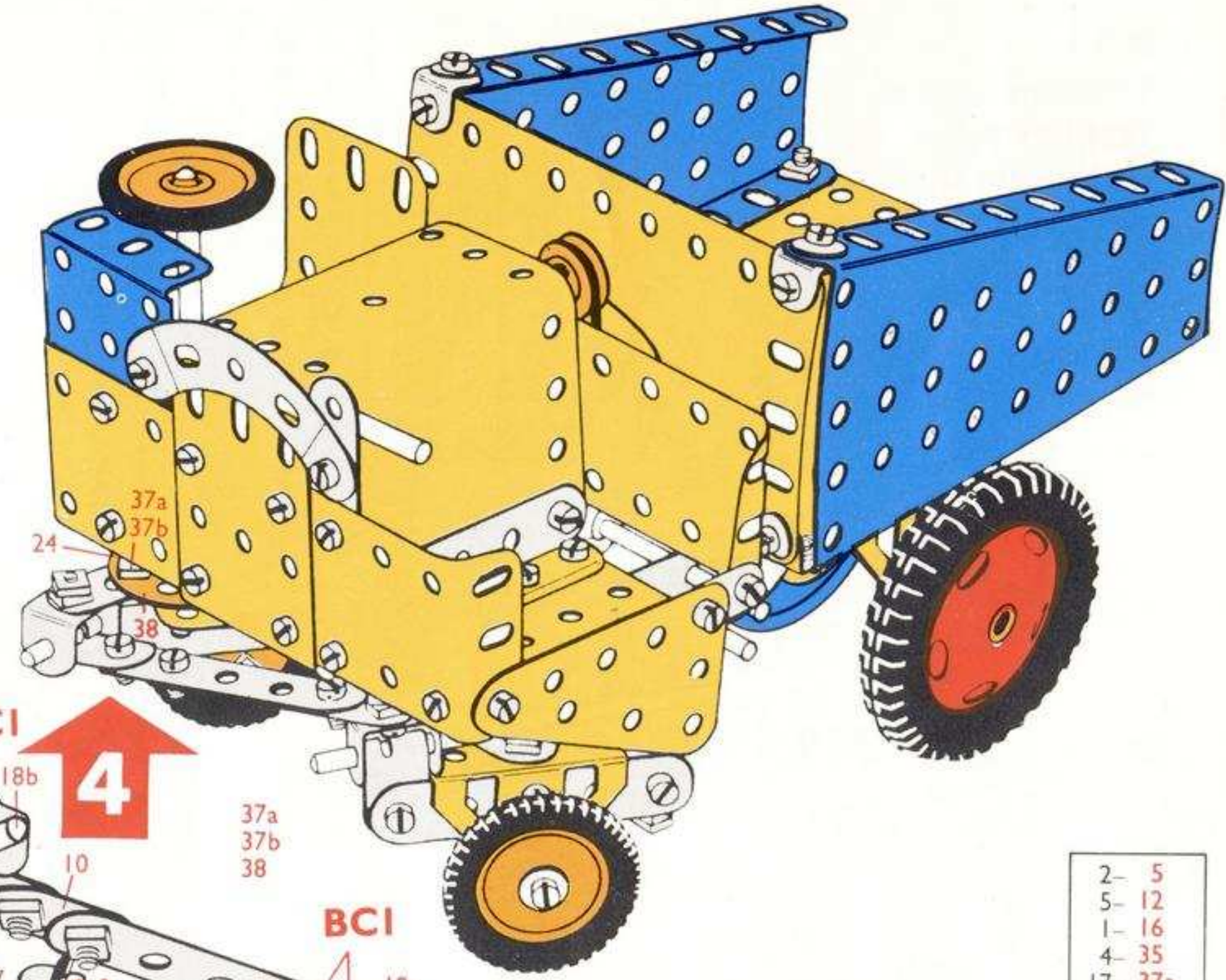

2- 5
5- 12
1- 16
4- 35
17- 37a
15- 37b
6- 38
1- 48a
1- 53a
2- 54
2- 111c
2- 191
1- 214

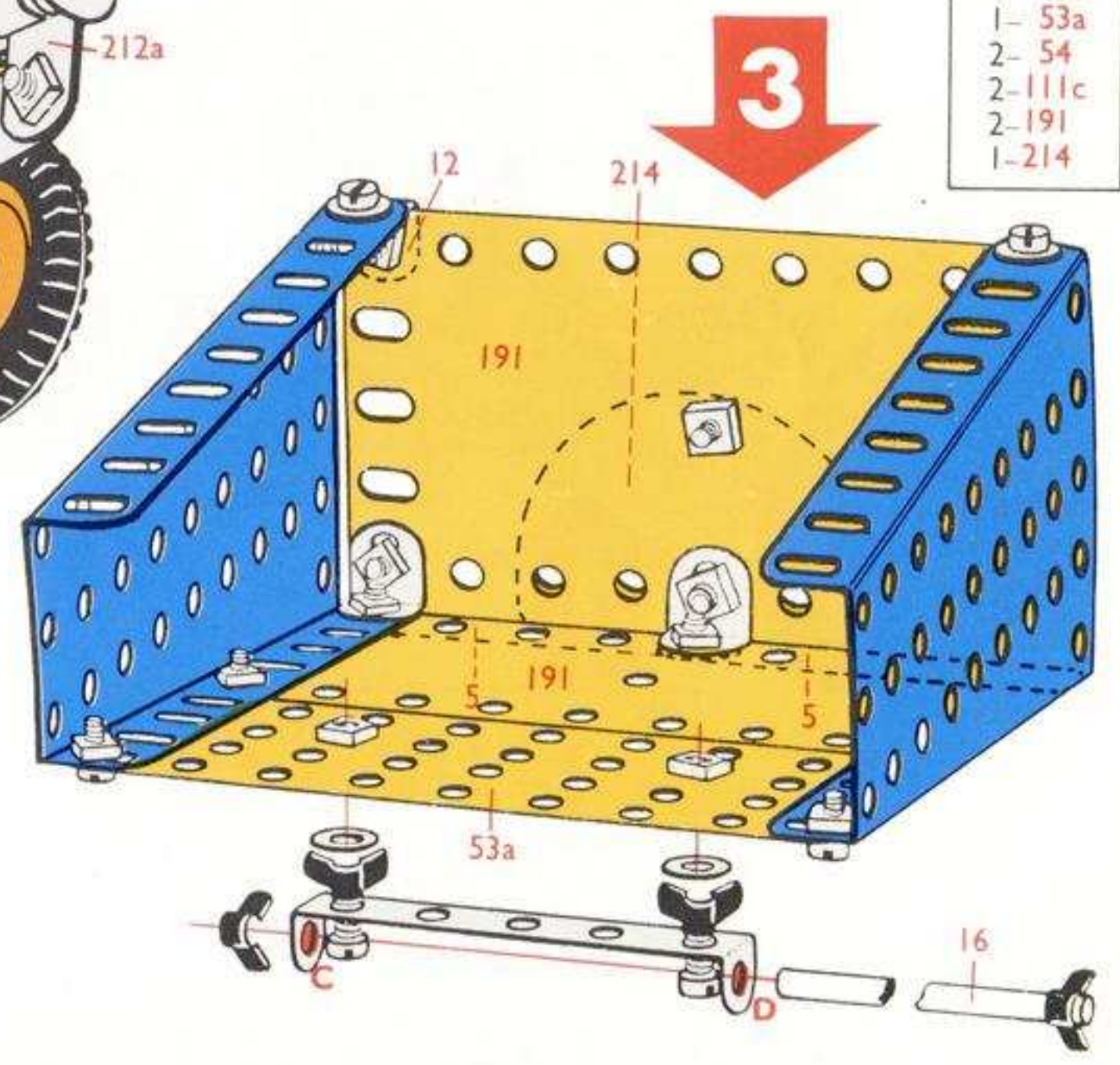

2- 2	1- 23a	2- 125
3- 5	2- 24	2- 126a
3- 10	9- 35	1- 155
1- 11a	48- 37a	*1- 186b
3- 12	46- 37b	2- 187
2- 15b	6- 38	2- 188
3- 16	1- 48	2- 189
1- 20a	5- 48a	1- 192
2- 22	1- 51	1- 212
2- 22a	1- 53a	2- 221
1- 23	4- 90a	
*1- 23a	3- 111c	



5.13.

Food Mixer
Mixer voor voedingsmiddelen
Mixer pour aliments
Frullino
Speisemixer
Hushållsmaskin
Batidora
Misturadora para cozinha
Matblander

7- 2	4- 22	3- 48a	2-126a
2- 3	1- 23	1- 51	*1-186b
8- 5	*1- 23a	1- 52	2-188
4- 10	1- 23a	2- 53a	2-189
2- 11	2- 24	2- 54	1-191
8- 12	2- 27f	4- 90a	2-192
2- 15b	2- 35	2-111	1-199
1- 17	87- 37a	1-111a	1-213
1- 18a	80- 37b	2-111c	2-214
1- 18b	13- 38	1-125	3-215
1- 20a	2- 48	2-126	*1-M5

* Non inclus dans la boîte
 * Not included in set

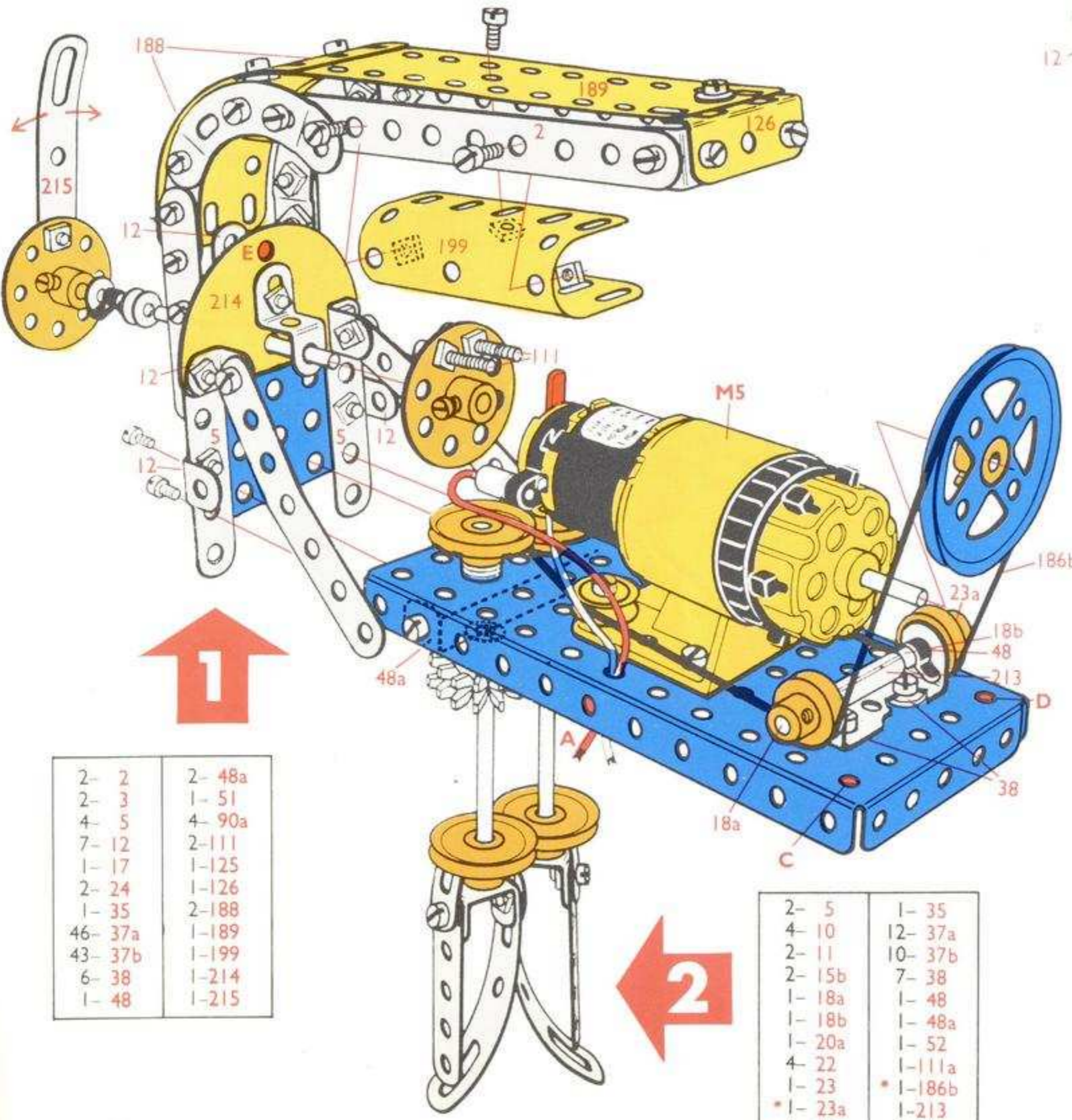

2- 2	2- 48a
2- 3	1- 51
4- 5	4- 90a
7- 12	2-111
1- 17	1-125
2- 24	1-126
1- 35	2-188
46- 37a	1-189
43- 37b	1-199
6- 38	1-214
1- 48	1-215

2- 5	1- 35
4- 10	12- 37a
2- 11	10- 37b
2- 15b	7- 38
1- 18a	1- 48
1- 18b	1- 48a
1- 20a	1- 52
4- 22	1-111a
1- 23	*1-186b
*1- 23a	1-213
1- 23a	2-215
2- 27f	

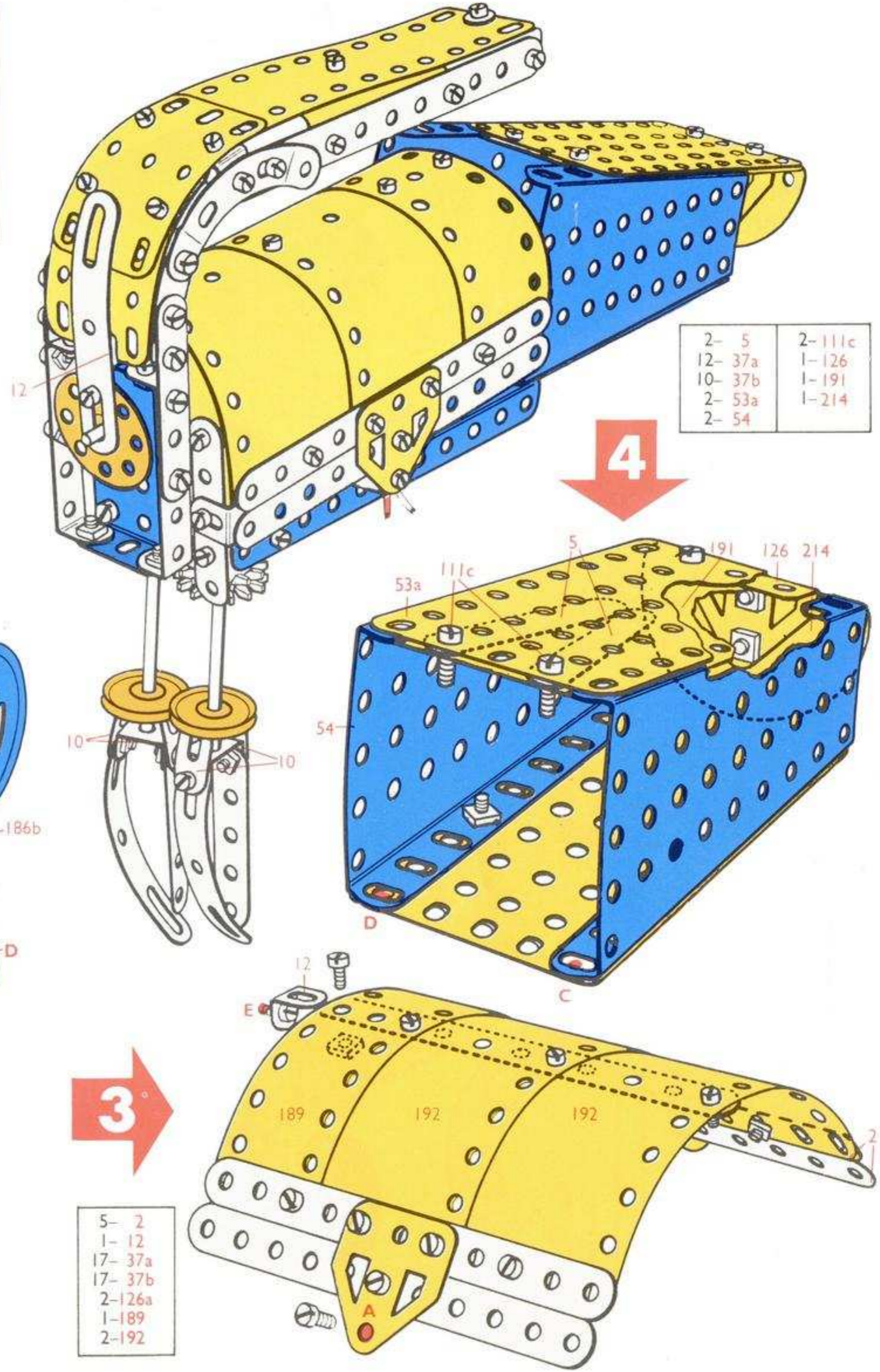

2- 5	2-111c
12- 37a	1-126
10- 37b	1-191
2- 53a	1-214
2- 54	

5- 2
1- 12
17- 37a
17- 37b
2-126a
1-189
2-192

5.14.

Scorpion
 Schorpioen
 Scorpione
 Skorpion
 Escorpión
 Escorpião

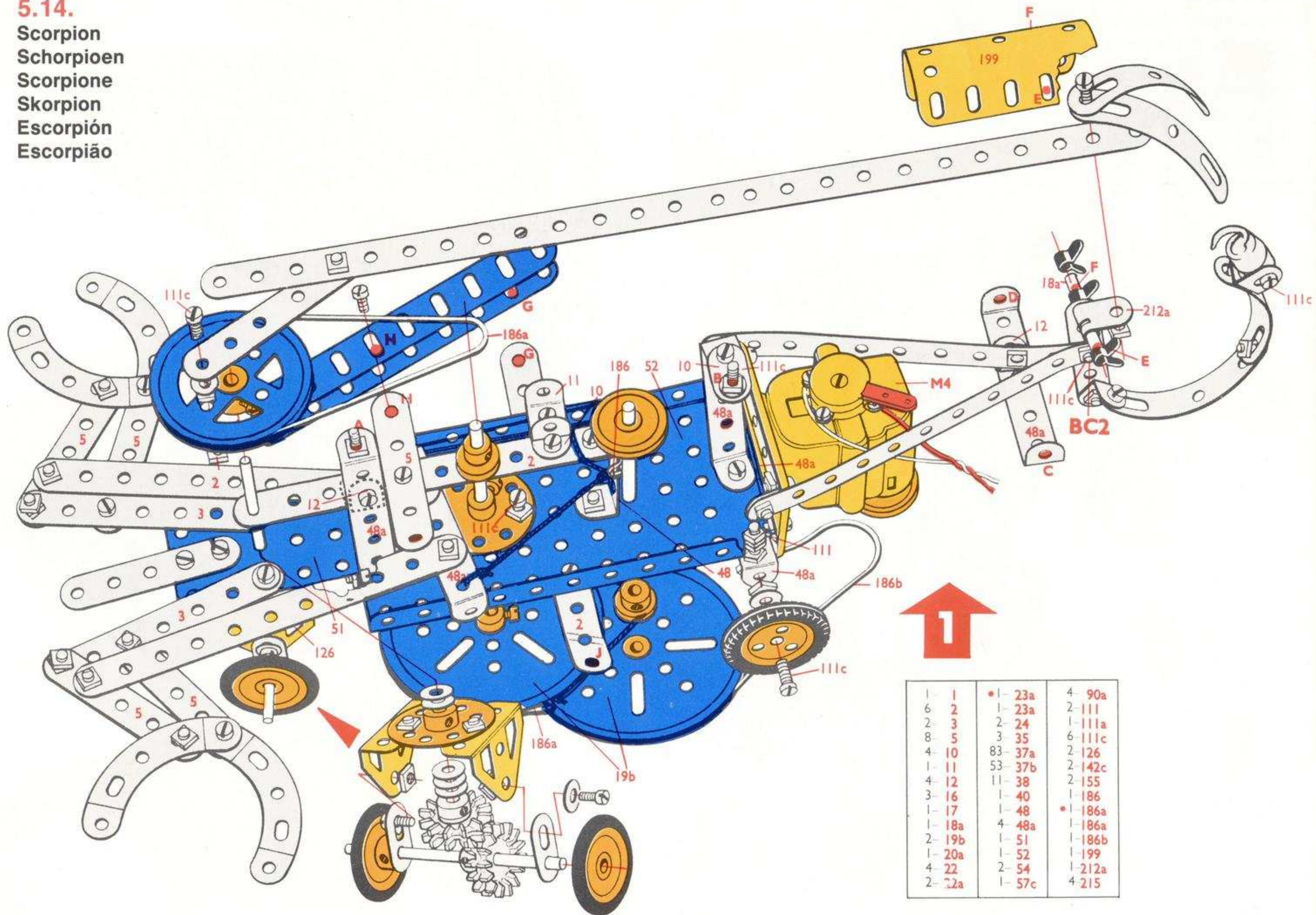

1- 1	• 1- 23a	4- 90a
6- 2	1- 23a	2- 111
2- 3	2- 24	1- 111a
8- 5	3- 35	6- 111c
4- 10	83- 37a	2- 126
1- 11	53- 37b	2- 142c
4- 12	11- 38	2- 155
3- 16	1- 40	1- 186
1- 17	1- 48	• 1- 186a
1- 18a	4- 48a	1- 186a
2- 19b	1- 51	1- 186b
1- 20a	1- 52	1- 199
4- 22	2- 54	1- 212a
2- 22a	1- 57c	4- 215

1- 1	2- 22a	1- 57c	2- 191
8- 2	*1- 23a	4- 90a	2- 192
2- 3	1- 23a	2- 111	1- 193
8- 5	2- 24	1- 111a	2- 194
4- 10	3- 35	6- 111c	1- 199
1- 11	107- 37a	2- 126	1- 200
4- 12	75- 37b	2- 142c	1- 212a
3- 12c	13- 38	2- 155	2- 214
3- 16	1- 40	1- 186	4- 215
1- 17	1- 48	*1- 186a	4- 221
1- 18a	4- 48a	1- 186a	*1- M4
2- 19b	1- 51	1- 186b	
1- 20a	1- 52	1- 189	
4- 22	2- 54	4- 190	

* Non inclus dans la boîte
 * Not included in set

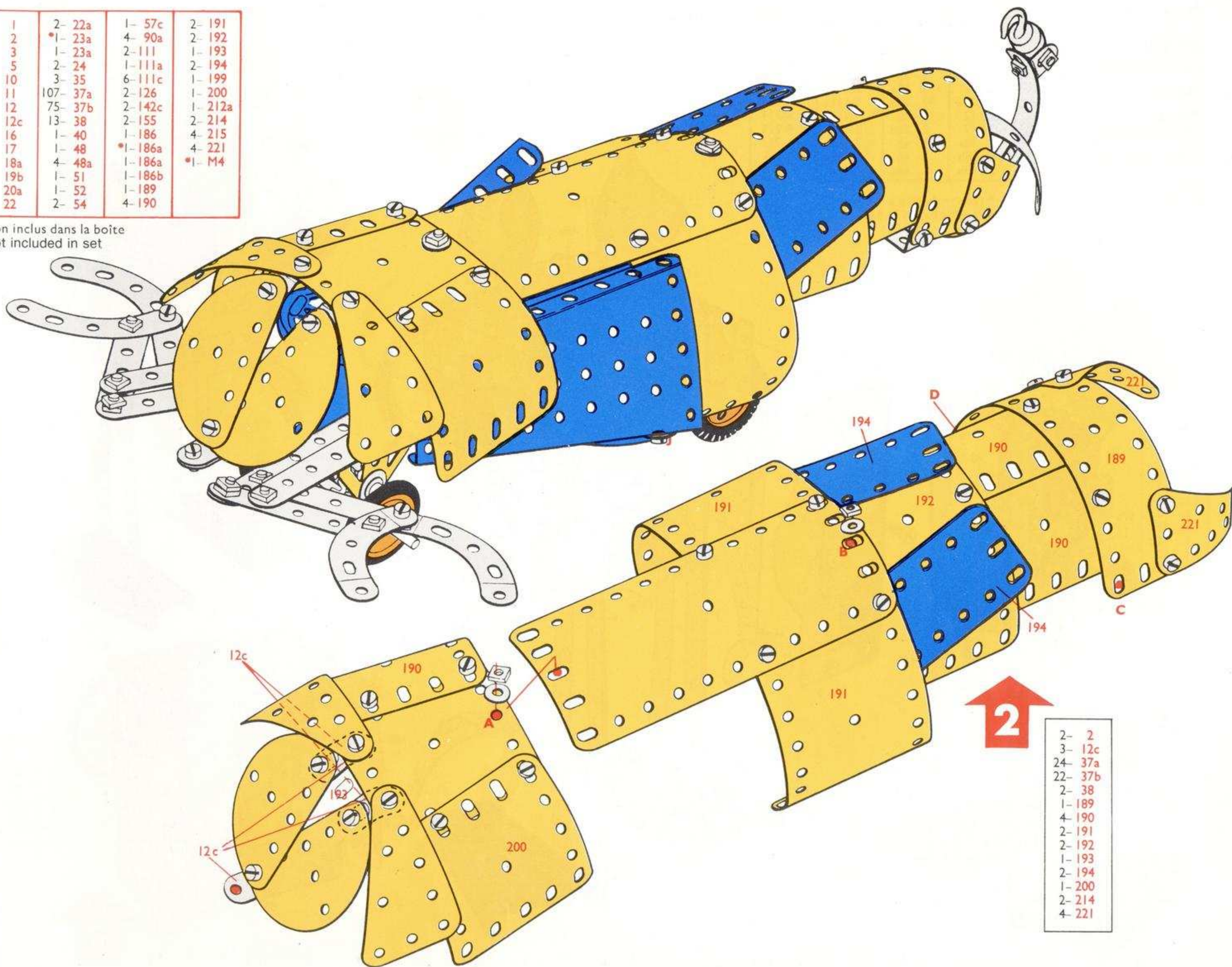

2

2- 2
3- 12c
24- 37a
22- 37b
2- 38
1- 189
4- 190
2- 191
2- 192
1- 193
2- 194
1- 200
2- 214
4- 221

5.15.

- Martian
- Marsbewoner
- Martien
- Marziano
- Marsmensch
- Marsinnevånare
- Marciano
- Marsianer

4- 1	1- 20a	1- 51	2-189
8- 2	1- 22	1- 52	4-190
2- 3	1- 23a	2- 53a	2-191
9- 5	2- 24	2- 54	2-192
2- 10	2- 35	3- 90a	2-194a
2- 11	105- 37a	2-111	1-200
1- 11a	94- 37b	1-111a	1-212a
10- 12	17- 38	4-111c	2-214
2- 17	2- 38d	2-126	4-215
1- 18a	1- 40	2-126a	4-221
1- 18b	2- 48	2-187	*1-M5
2- 19b	6- 48a	2-188	

4- 2	2- 38d
1- 3	2-111c
2- 12	1-192
2- 17	2-194a
2- 19b	2-214
2- 35	4-215
21- 37a	4-221
19- 37b	

* Non inclus dans la boîte
 * Not included in set

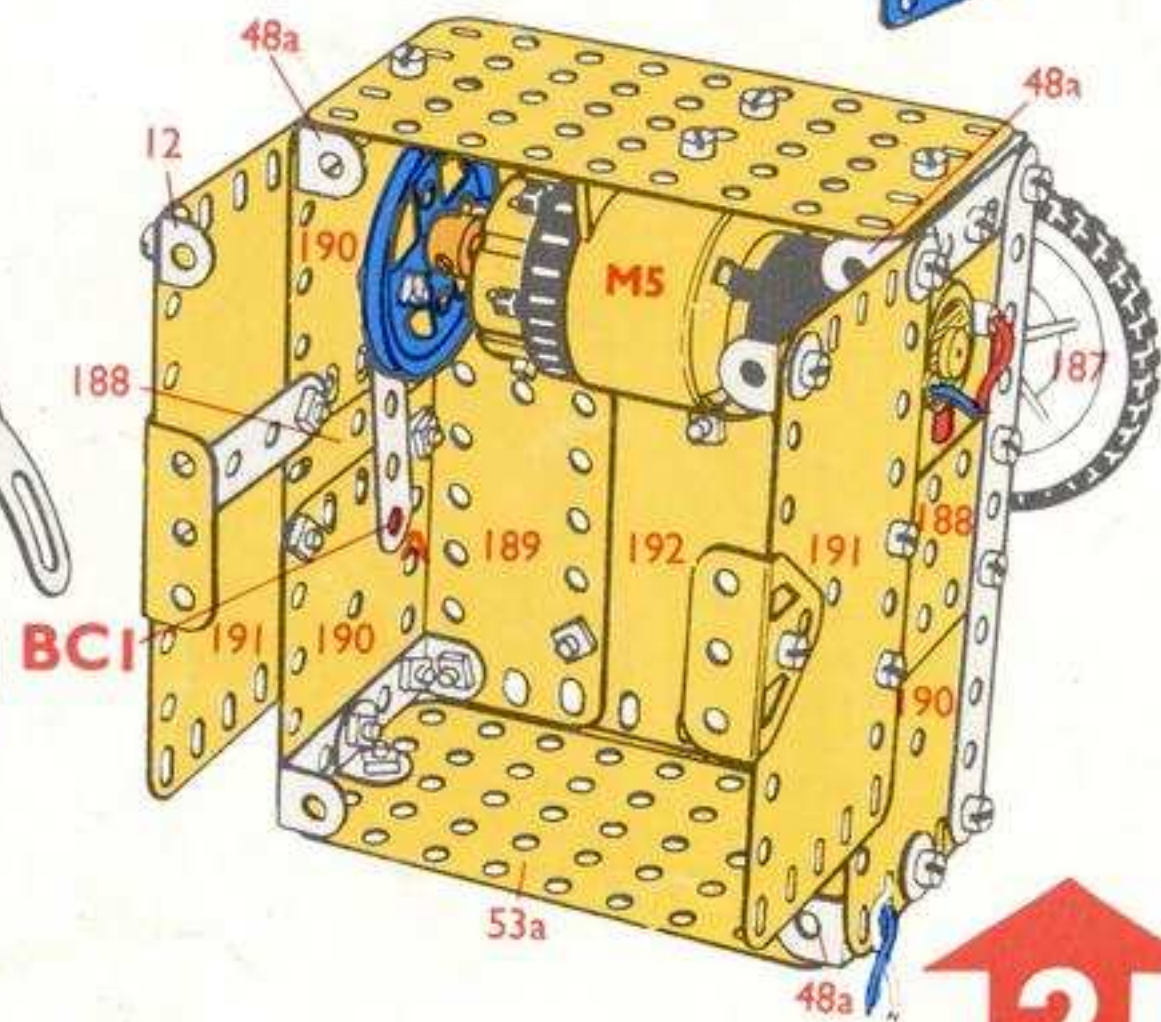
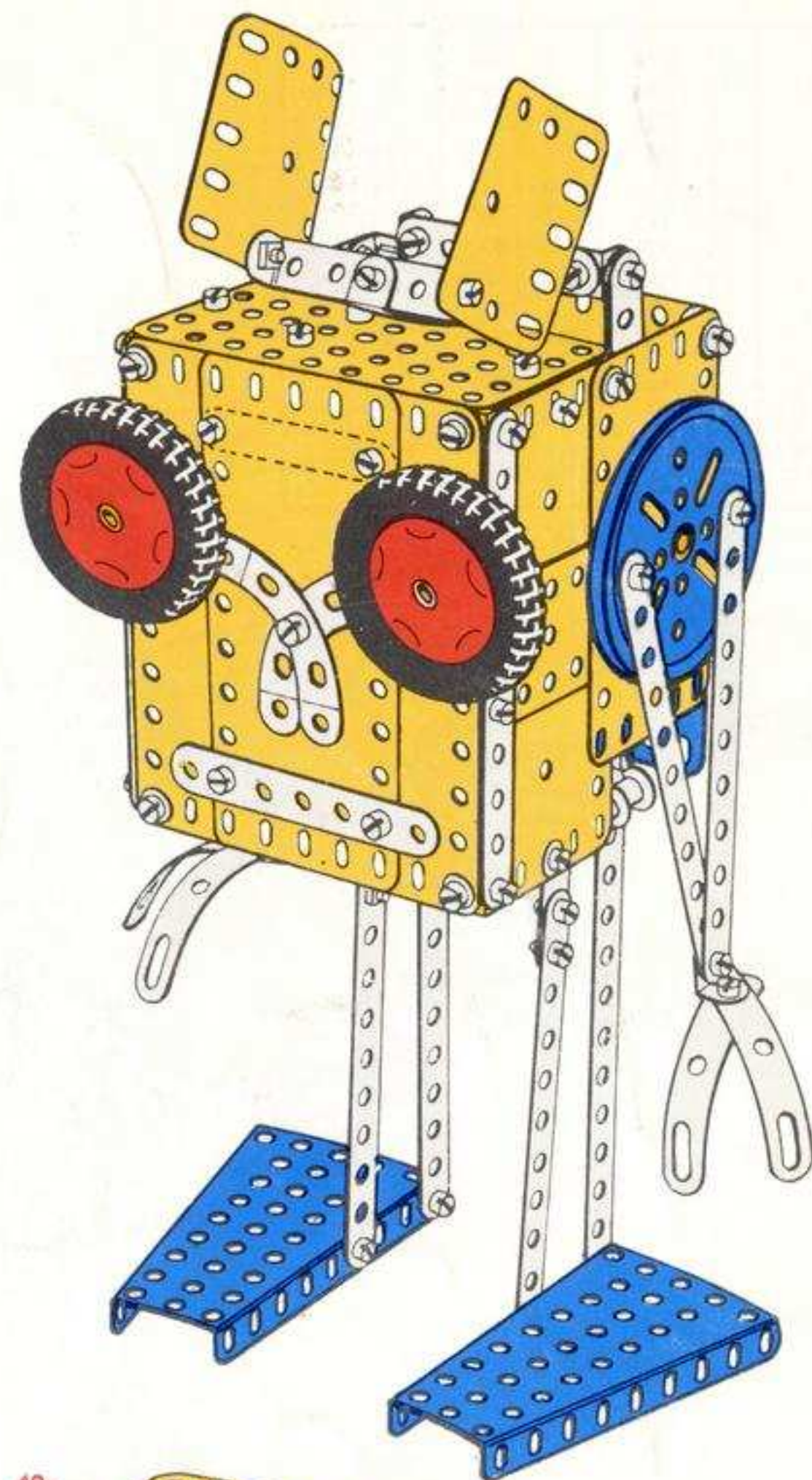
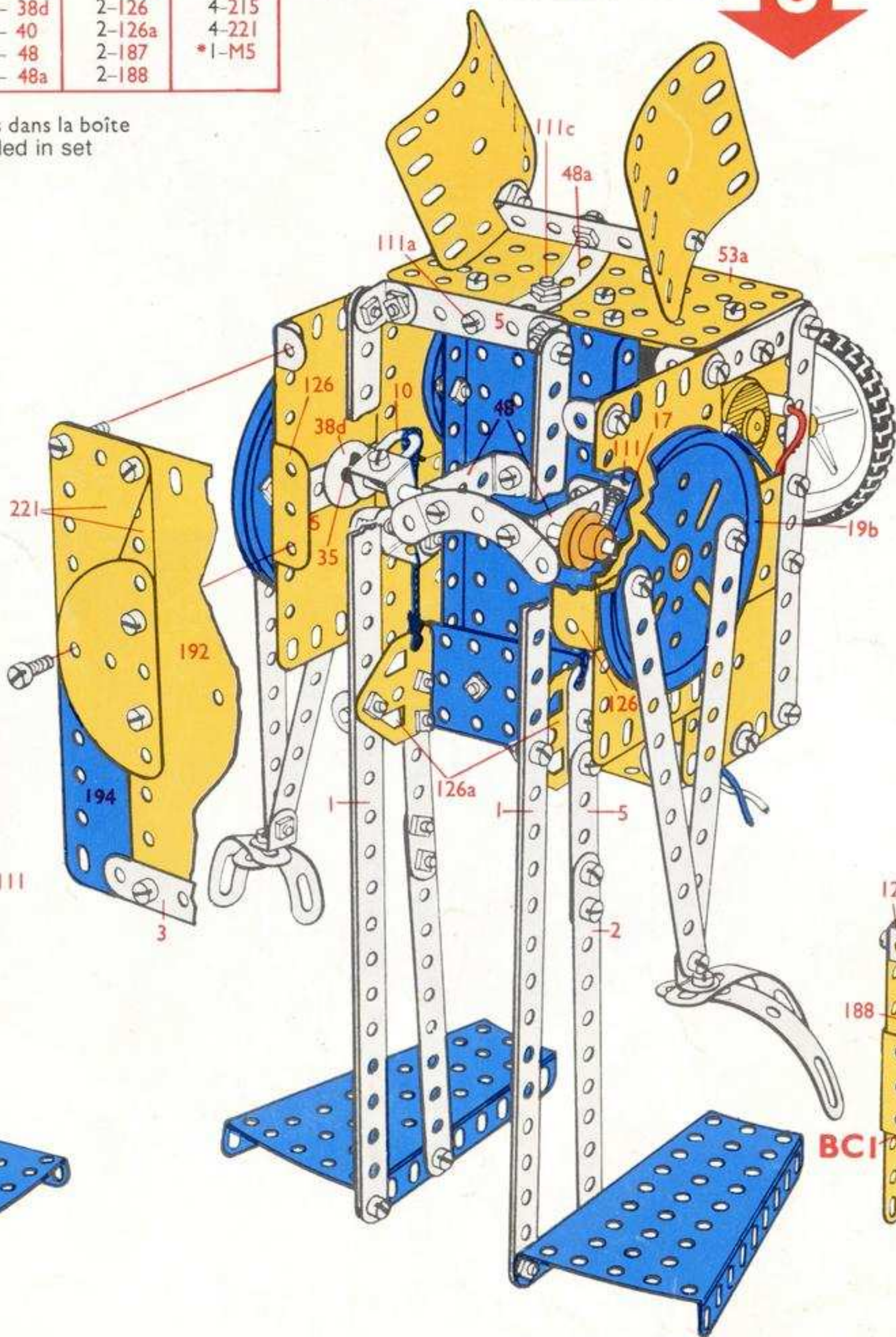
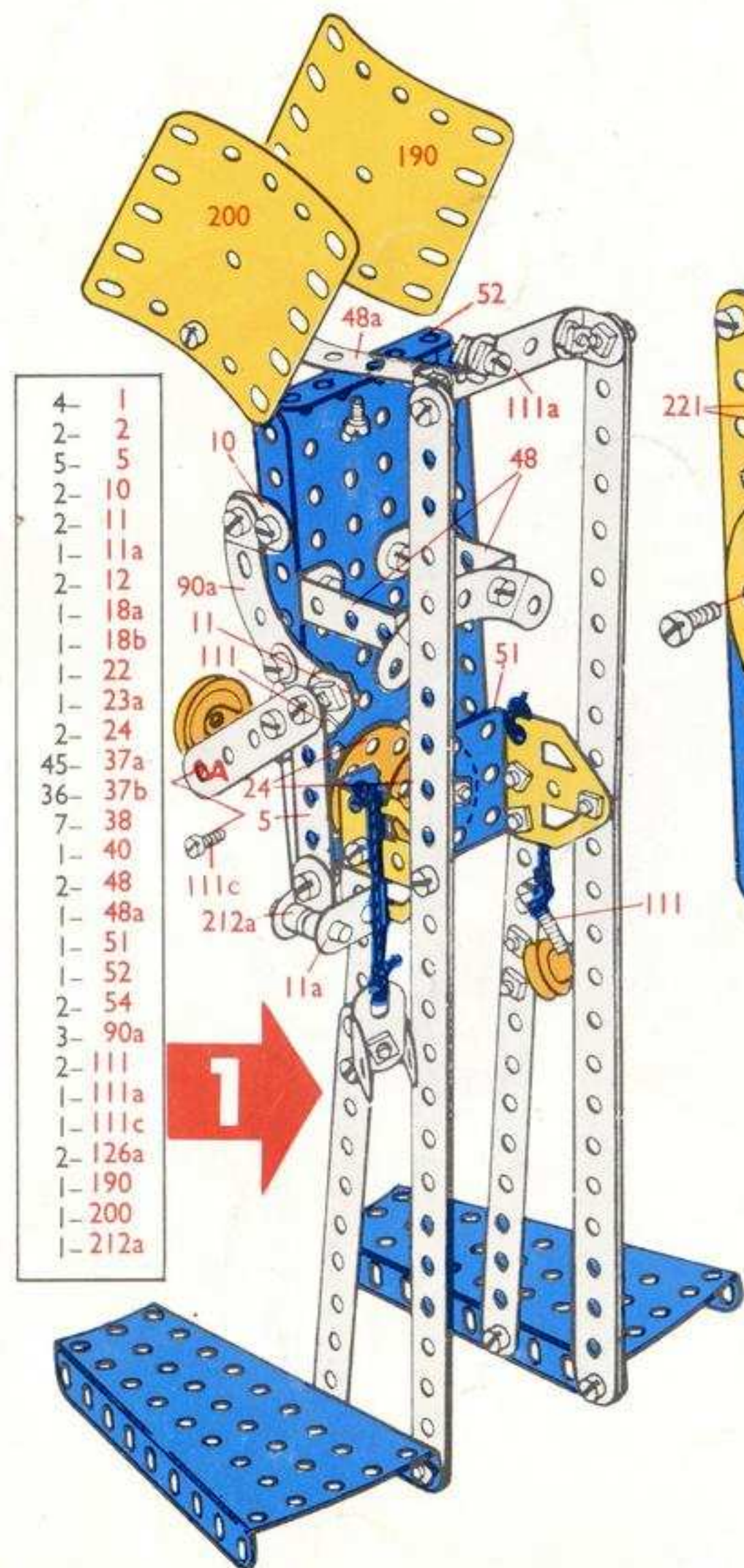

2- 2
1- 3
4- 5
6- 12
1- 20a
39- 37a
39- 37b
10- 38
4- 48a
2- 53a
1-111c
2-126
2-187
2-188
2-189
3-190
2-191
1-192

ELECTRONIC 5.16.

Automatic Press
 Automatische pers
 Presse automatique
 Pressa automatica
 Automatische Presse
 Automatisk press
 Prensa automatica
 Prensa Automatica
 Automatpresse

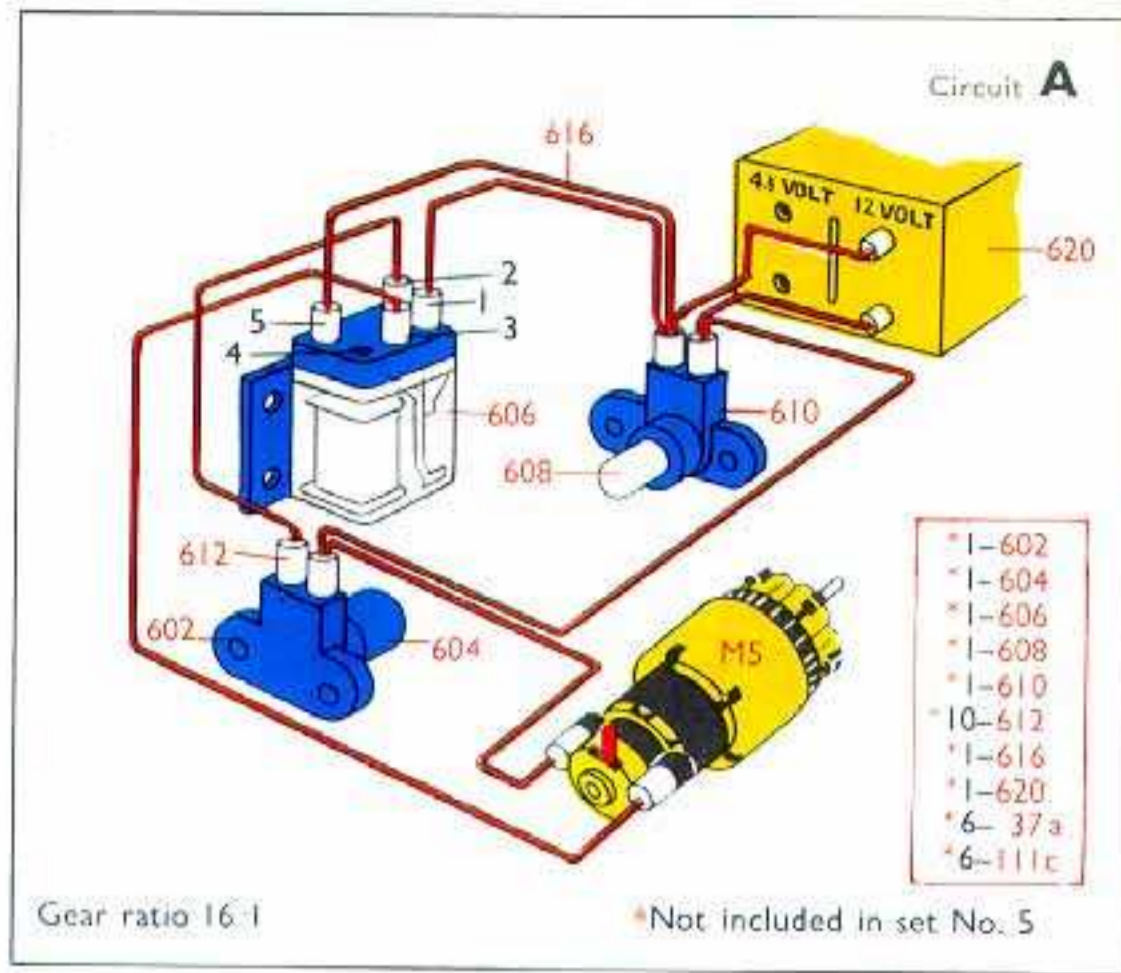

8- 2	1- 23a	1-111a
1- 3	2- 24	5-111c
5- 5	2- 27f	2-126
2- 10	7- 35	2-126a
2- 15b	52- 37a	1-186a
1- 16	44- 37b	*1-186b
2- 17	16- 38	1-191
2- 18a	2- 48	1-212
1- 18b	6- 48a	1-213
1- 19b	1- 51	2-214
1- 20a	1- 52	*1-M5
4- 22	2- 53a	
*1- 23a	2- 54	

*Not included in set No. 5

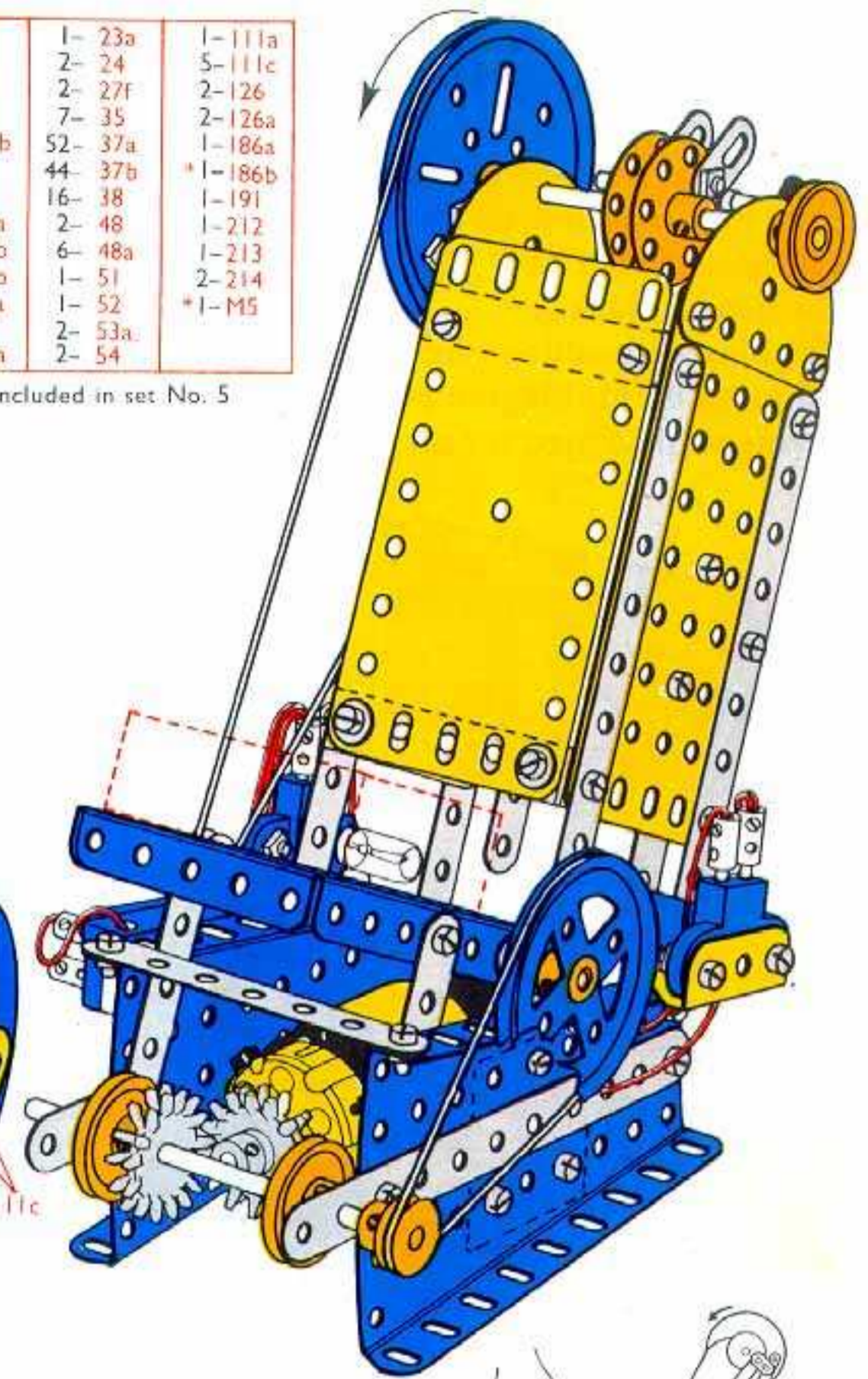

2- 2	2- 35
1- 3	16- 37a
2- 5	14- 37b
2- 15b	8- 38
1- 20a	1- 52
2- 22	2- 54
1- 23a	2-111c
*1- 23a	2-126
2- 27f	1-186a

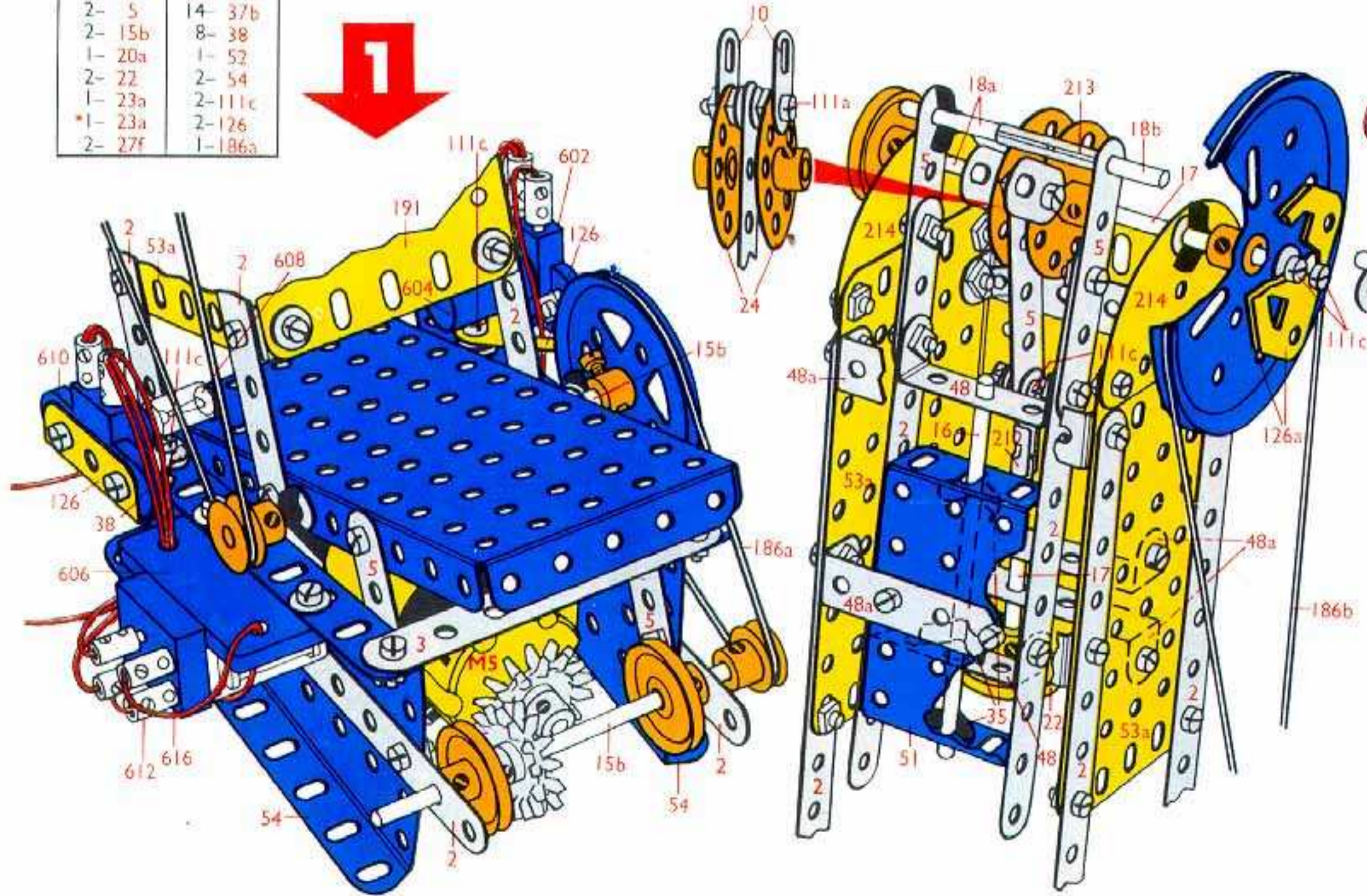

6- 2	2- 24	1-111a
3- 5	5- 35	3-111c
2- 10	29- 37a	2-126a
1- 16	22- 37b	1-186b
1- 17	8- 38	1-191
2- 18a	2- 48	1-212
1- 18b	6- 48a	1-213
1- 19b	1- 51	2-214
2- 22	2- 53a	



ELECTRONIC 5.17.

Injection Moulding Machine

Spuitsietmachine

Machine à moulage par injection

Formatrice ad iniezione

Spritgussmaschine

Formsprutmaskin

Máquina de moldeo por inyección

Máquina de Moldagem por Injecção

Formemaskin med innsprøytning

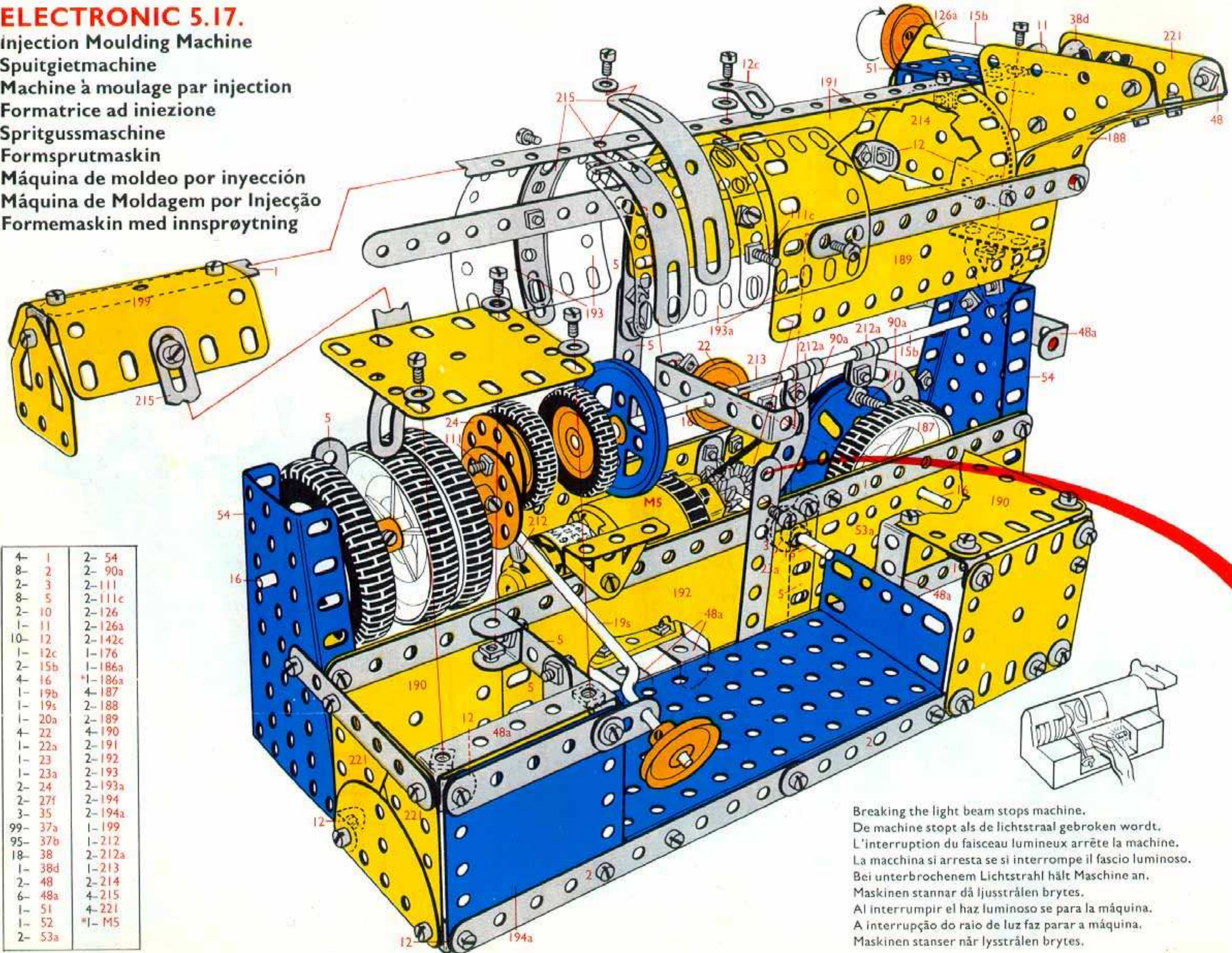

4-	1	2-	54
8-	2	2-	90a
2-	3	2-	111
8-	5	2-	111c
2-	10	2-	126
1-	11	2-	126a
10-	12	2-	142c
1-	12c	1-	176
2-	15b	1-	186a
4-	16	*1-	186a
1-	19b	4-	187
1-	19s	2-	188
1-	20a	2-	189
4-	22	4-	190
1-	22a	2-	191
1-	23	2-	192
1-	23a	2-	193
2-	24	2-	193a
2-	27f	2-	194
3-	35	2-	194a
99-	37a	1-	199
95-	37b	1-	212
18-	38	2-	212a
1-	38d	1-	213
2-	48	2-	214
6-	48a	4-	215
1-	51	4-	221
1-	52	*1-	M5
2-	53a		

Breaking the light beam stops machine.
 De machine stopt als de lichtstraal gebroken wordt.
 L'interruption du faisceau lumineux arrête la machine.
 La macchina si arresta se si interrompe il fascio luminoso.
 Bei unterbrochenem Lichtstrahl hält Maschine an.
 Maskinen stannar då ljustrålen brytes.
 Al interrumpir el haz luminoso se para la máquina.
 A interrupção do raio de luz faz parar a máquina.
 Maskinen stanser når lysstrålen brytes.

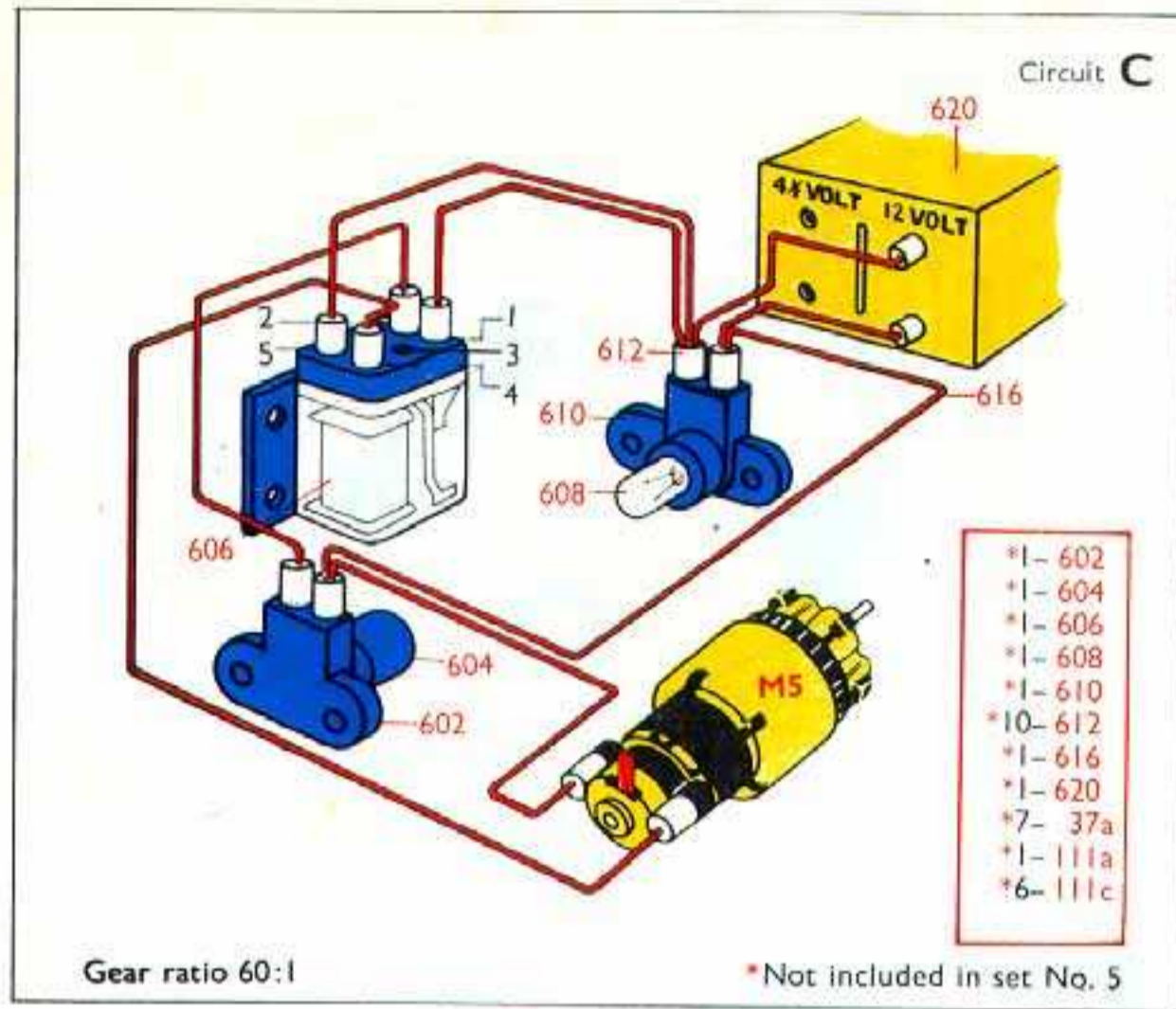

4- 1	1- 23	2- 90a	2- 193
8- 2	1- 23a	2- 111	2- 193a
2- 3	2- 24	2- 111c	2- 194
8- 5	2- 27f	2- 126	2- 194a
2- 10	3- 35	2- 126a	1- 199
1- 11	99- 37a	2- 142c	1- 212
10- 12	95- 37b	1- 176	2- 212a
1- 12c	18- 38	1- 186a	1- 213
2- 15b	1- 38d	*1- 186a	2- 214
4- 16	2- 48	4- 187	4- 215
1- 19b	6- 48a	2- 188	4- 221
1- 19s	1- 51	2- 189	*1- M5
1- 20a	1- 52	4- 190	
4- 22	2- 53a	2- 191	
1- 22a	2- 54	2- 192	

*Not included in set No. 5

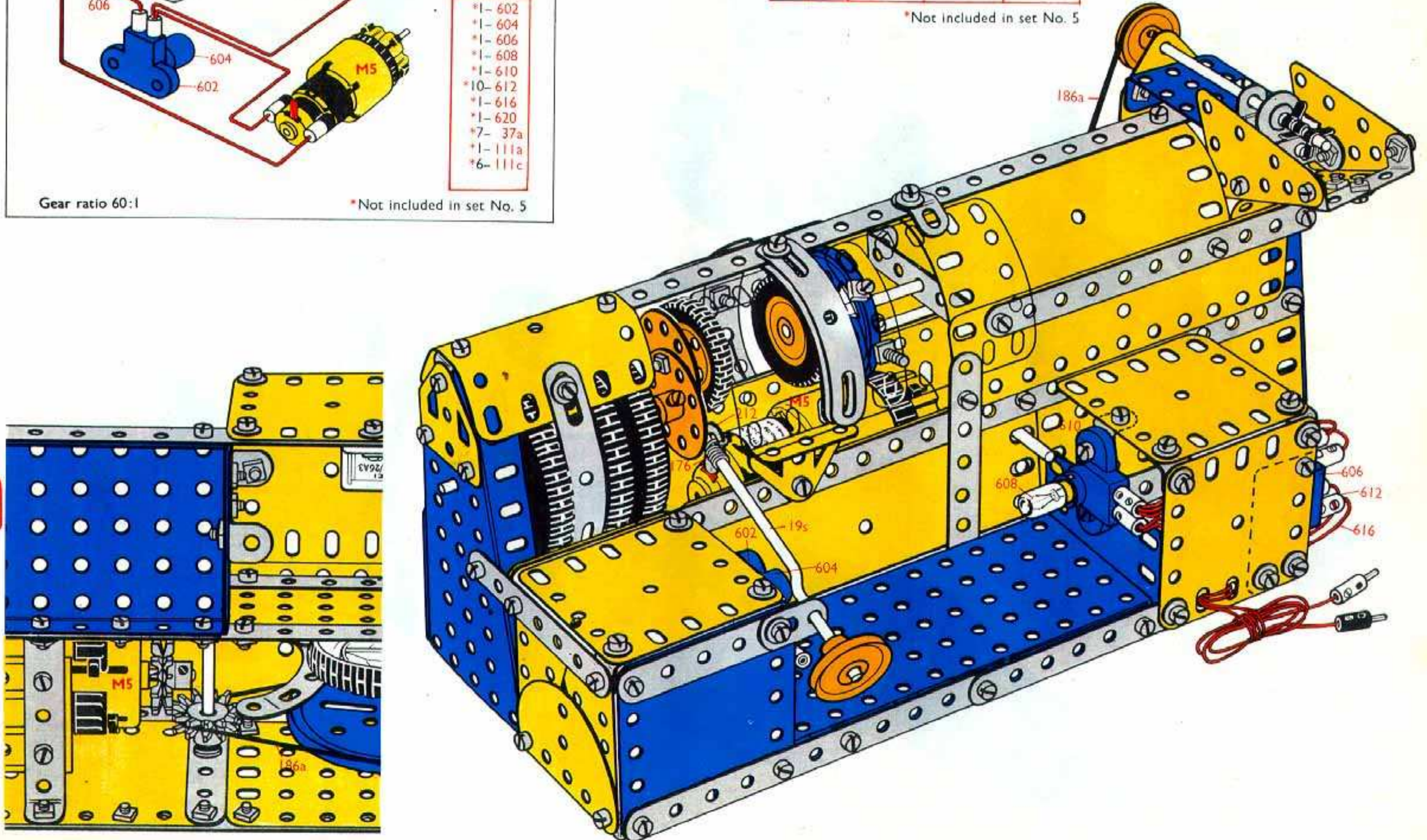

ELECTRONIC 5.18.

- Counting Conveyor
- Teltransporteur
- Convoyeur-compteur
- Trasportatore contatore
- Zahlforderer
- Transportor med rakneverk
- Transportador contador
- Transportador Contador
- Telletransportor

4- 1	1- 23a	2-111a
5- 2	2- 24	2-111c
2- 3	2- 27f	2-126
9- 5	14- 35	2-126a
4-10	87- 37a	1-155
2-11	71- 37b	1-186
1-11a	18- 38	1-186a
8-12	2- 38d	*1-186a
2-15b	1- 40	2-190
4-16	1- 48	2-192
1-17	6- 48a	1-212
2-19b	1- 51	2-212a
1-20a	1- 52	1-213
4-22	2- 53a	2-214
2-22a	2- 54	*1-M5
1-23	4- 90a	
*1-23a	1-111	

*Not included in set No. 5

