

MECCANO®

**BOOK OF MODELS
VOORBEELDENBOEK
LIVRE DES MODÈLES
LIBRO DEI MODELLI
MODELLBUCH
MODELLBOK
LIBRO DE MODELOS
LIVRO DE MODELOS
MODELLBOK**

5/6

Complete list of Meccano Parts
 Komplete lijst van Meccano-onderdelen
 Liste complète des pièces Meccano
 Distinta delle componenti del Corredo Meccano
 Vollständige Liste der Meccano-Teile
 Fullständig förteckning över Meccanodelar
 Lista completa de piezas de Meccano
 Lista completa de peças do Meccano
 Komplet list over Meccanodeler



- PERFORATED STRIPS**
- | | | |
|----|--------------------|------------------|
| 5 | 1 - 12 1/2"; 32 cm | 3 - 3 1/2"; 9 cm |
| 1a | 9 1/2"; 24 cm | 4 - 3"; 7 1/2 cm |
| 1b | 7 1/2"; 19 cm | 5 - 2 1/2"; 6 cm |
| 2 | 5 1/2"; 14 cm | 6 - 2"; 5 cm |
| 2a | 4 1/2"; 11 1/2 cm | 6a 1 1/2"; 38 mm |



- ANGLE GIRDERS**
- | | | | |
|----|----------------|----|-------------------|
| 7 | 24 1/2"; 62 cm | 9a | 4 1/2"; 11 1/2 cm |
| 7a | 18 1/2"; 47 cm | 9b | 3 1/2"; 9 cm |
| 8 | 12 1/2"; 32 cm | 9c | 3"; 7 1/2 cm |
| 8a | 9 1/2"; 24 cm | 9d | 2 1/2"; 6 cm |
| 8b | 7 1/2"; 19 cm | 9e | 2"; 5 cm |
| 9 | 5 1/2"; 14 cm | 9f | 1 1/2"; 38 mm |



FISHPLATE
10



DOUBLE BRACKET
11 - 1/2" x 1/2"; 12 x 12 mm



DOUBLE BRACKET
11a - 1" x 1/2"; 25 x 12 mm



ANGLE BRACKETS
 12 - 1/2" x 1/2"; 12 x 12 mm
 12a - 1" x 1"; 25 x 25 mm
 12b - 1" x 1/2"; 25 x 12 mm



ANGLE BRACKET
(OBTUSE)
12c - 1/2" x 1/2"; 12 x 12 mm



- AXLE RODS**
- | | | | |
|-----|-------------------|-----|---------------|
| 13 | 11 1/2"; 29 cm | 16 | 3 1/2"; 9 cm |
| 13a | 8"; 20 cm | 16a | 2 1/2"; 6 cm |
| 14 | 6 1/2"; 16 1/2 cm | 16b | 3"; 7 1/2 cm |
| 14a | 5 1/2"; 14 cm | 17 | 2"; 5 cm |
| 15 | 5"; 13 cm | 18a | 1 1/2"; 38 mm |
| 15a | 4 1/2"; 11 1/2 cm | 18b | 1"; 25 mm |
| 15b | 4"; 10 cm | | |



SPOKED WHEEL
19a - 3"; 75 mm



PULLEYS
 19b - 3"; 75 mm
 19c - 2"; 5 cm



PULLEY
19c - 6"; 15 cm



CRANK HANDLE
 19h - 5"; 13 cm
 19a - 3 1/2"; 9 cm



FLANGED WHEELS
20 - 1 1/2"; 28 mm



20b - 1"; 19 mm



PULLEY
21 - 1 1/2"; 38 mm



PULLEY
22 - 1"; 25 mm



PULLEYS
 22a - 1"; 25 mm
 23 plastic - 1/2"; 12 mm
 23a - 1/2"; 12 mm
 23b metal - 1/2"; 12 mm



BUSH WHEEL
24 - 1 1/2"; 34 mm



WHEEL DISC
24a - 1 1/2"; 34 mm



BUSH WHEEL
24b - 1 1/2"; 34 mm



WHEEL DISC
24c - 1 1/2"; 34 mm



- PINIONS**
- | | |
|-----|---------------------------|
| 25 | 1 1/2" x 1/2"; 19 x 6 mm |
| 25a | 1 1/2" x 1/2"; 19 x 12 mm |
| 25b | 1 1/2" x 1/2"; 19 x 19 mm |
| 26 | 1 1/2" x 1/2"; 12 x 6 mm |
| 26a | 1 1/2" x 1/2"; 12 x 12 mm |
| 26b | 1 1/2" x 1/2"; 12 x 19 mm |
| 26c | 1 1/2" x 1/2"; 11 x 6 mm |



GEAR WHEELS
 27 - 1 1/2"; 32 mm
 27a - 1 1/2"; 38 mm
 27d - 1 1/2"; 41 mm



GEAR WHEELS
 27b - 3 1/2"; 9 cm
 27c - 2 1/2"; 6 cm



MULTI-PURPOSE GEAR WHEEL
28



CONTRATE WHEEL
29 - 1 1/2"; 38 mm
29 - 1 1/2"; 19 mm



BEVEL GEAR
For use in pairs.
30 - 1 1/2"; 22 mm



30a - 1 1/2"; 12 mm



BEVEL GEARS
can only be used together.
30b - 1 1/2"; 12 mm
30c - 1 1/2"; 38 mm



GEAR WHEEL
31 - 1" x 1/2"
25 mm x 6 mm



WORM
32 - 1/2"; 12 mm



SPANNER
34

BOX SPANNER
34b



SPRING CLIP
35

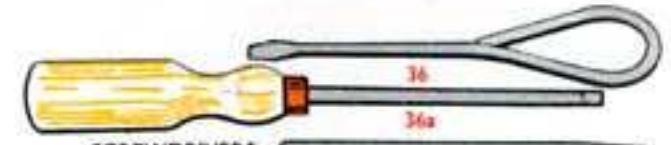

SCREWDRIVERS
36

DRIFT
36a



BOLT
37b - 1/2"; 5 mm



NUT
37a

NUT AND BOLT
37



WASHERS
38 - 1/2"; 10 mm
38d - 1/2"; 19 mm



38c - 1/2"; 19 mm



HANK OF CORD
40



PROPELLER BLADE
41



TENSION SPRING
43 - 2"; 5 cm



BENT STRIP STEPPED
44



DOUBLE BENT STRIP
45



- DOUBLE ANGLE STRIPS**
- | | |
|-----|-----------------------------|
| 46 | 2 1/2" x 1"; 60 x 25 mm |
| 47 | 2 1/2" x 1 1/2"; 60 x 38 mm |
| 47a | 3" x 1 1/2"; 75 x 38 mm |
| 48 | 1 1/2" x 1"; 38 x 12 mm |
| 48a | 2 1/2" x 1"; 60 x 12 mm |
| 48b | 3" x 1"; 90 x 12 mm |
| 48c | 4" x 1"; 115 x 12 mm |
| 48d | 5" x 1"; 140 x 12 mm |



SLIDE PIECE
50

5.1

Car Ferry
Autovervoerboot
Ferry-boat pour voitures
Traghetto per automobili
Autofähre
Bilfärja
Buque transbordador de vehiculos
Ferry-boat
Bilferge

| | | |
|-------|---------|--------|
| 4- 1 | 2- 35 | 2-126 |
| 8- 2 | 107-37a | 2-126a |
| 2- 3 | 93- 37b | 4-142c |
| 8- 5 | 11- 38 | 2-155 |
| 3-10 | 2- 38d | 2-188 |
| 2-11 | 1- 40 | 2-189 |
| 1-11a | 2- 48 | 4-190 |
| 10-12 | 5- 48a | 2-191 |
| 1-12c | 1- 51 | 2-192 |
| 4-16 | 1- 52 | 1-193 |
| 1-18a | 2- 53a | 2-194 |
| 1-18b | 2- 54 | 1-212 |
| 4-22 | 2- 90a | 2-212a |
| 2-22a | 2-111 | 2-214 |
| 1-23 | 4-111c | 4-221 |
| 2-24 | 2-125 | |

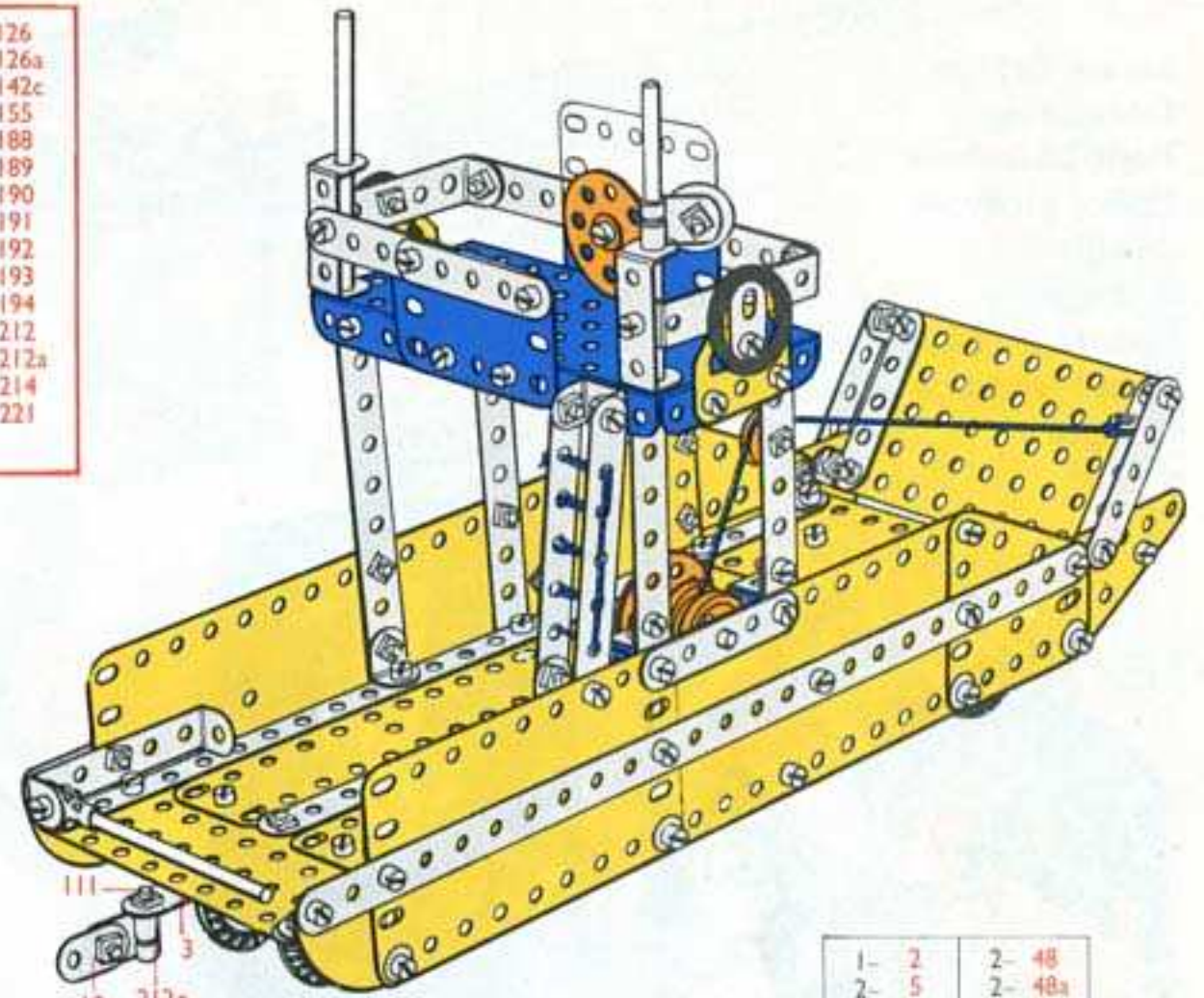

| | |
|--------|--------|
| 4- 1 | 1- 40 |
| 7- 2 | 3- 48a |
| 2- 3 | 1- 51 |
| 6- 5 | 2- 53a |
| 1-10 | 2- 54 |
| 2-11 | 2- 90a |
| 1-11a | 1-111 |
| 10-12 | 2-111c |
| 1-12c | 2-125 |
| 2-16 | 2-126 |
| 1-18a | 4-142c |
| 1-18b | 2-188 |
| 4-22 | 2-189 |
| 2-22a | 4-190 |
| 1-23 | 2-191 |
| 1-24 | 2-192 |
| 81-37a | 1-212 |
| 73-37b | 1-212a |
| 10-38 | 2-214 |
| 1-38d | 4-221 |

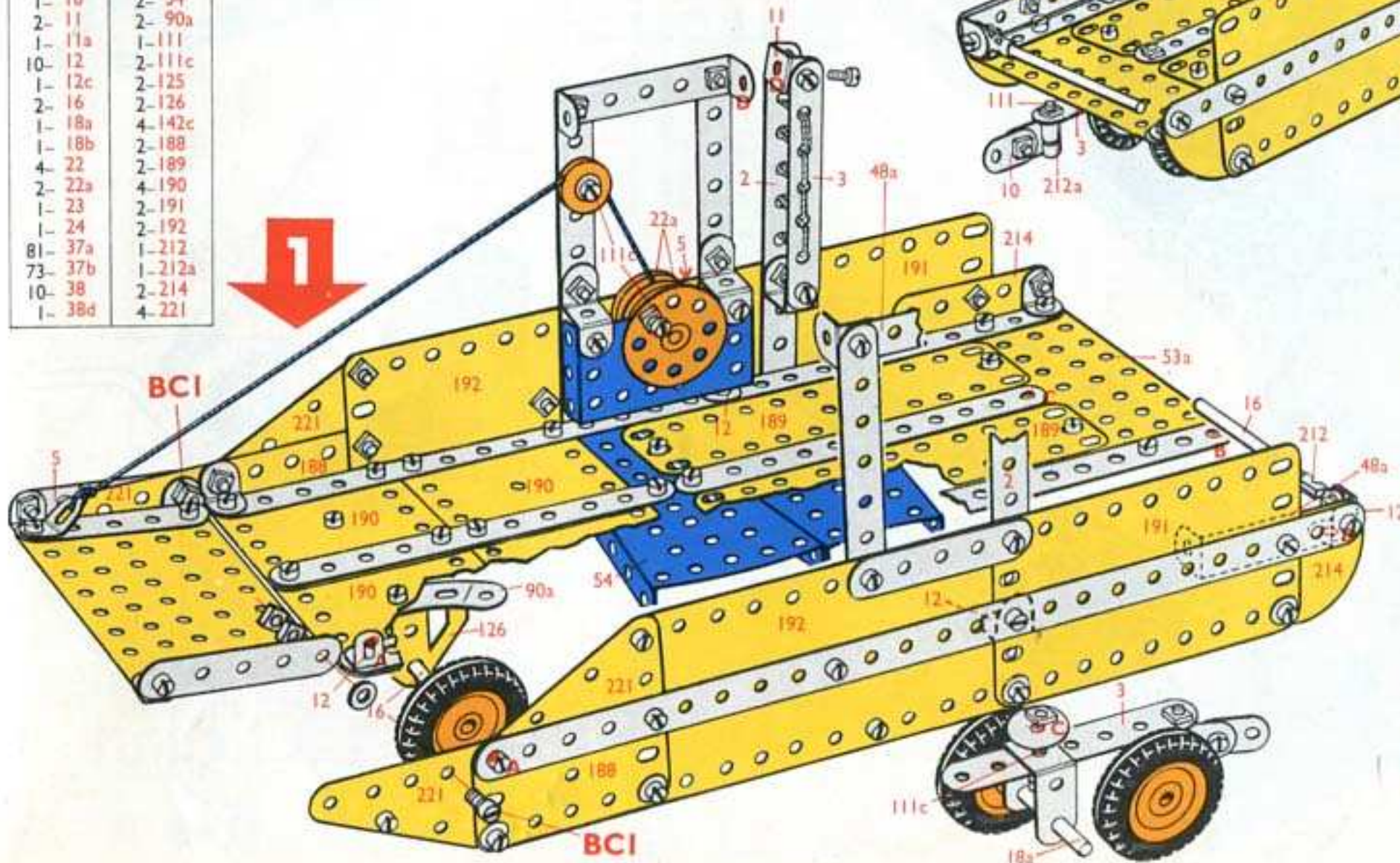

| | |
|--------|--------|
| 1- 2 | 2- 48 |
| 2- 5 | 2- 48a |
| 2-10 | 1- 52 |
| 2-16 | 1-111 |
| 1-24 | 2-111c |
| 2-35 | 2-126a |
| 26-37a | 2-155 |
| 20-37b | 1-193 |
| 1-38 | 2-194 |
| 1-38d | 1-212a |

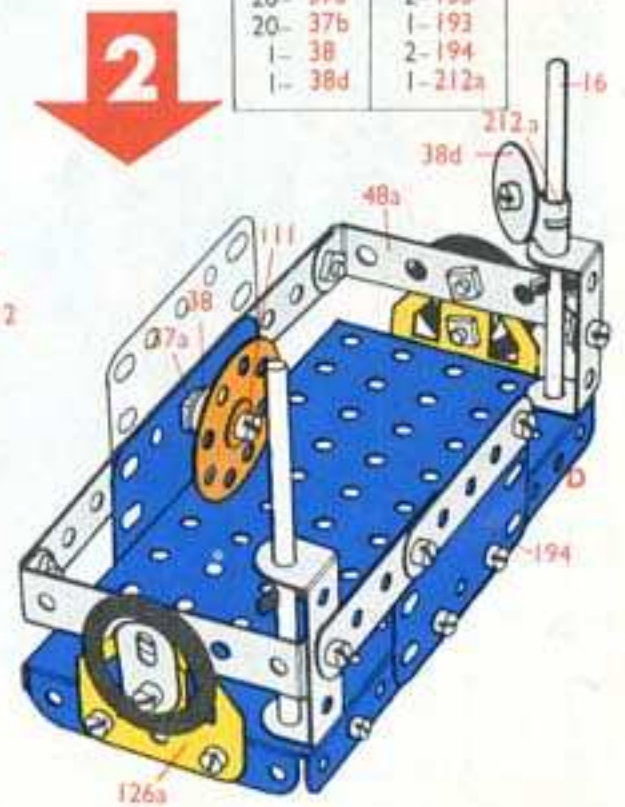

5.2

Swing Bridge
Draaibrug
Pont basculant
Ponte girevole
Drehbrücke
Svängbro
Puente giratorio
Ponte levadiça
Svingbro

| | | |
|--------|----------|---------|
| 4- 1 | 2- 24 | 4- 111c |
| 8- 2 | 2- 27f | 2- 125 |
| 2- 3 | 4- 35 | 2- 126 |
| 9- 5 | 101- 37a | 2- 126a |
| 4- 10 | 93- 37b | 2- 188 |
| 1- 11 | 13- 38 | 2- 189 |
| 9- 12 | 1- 40 | 4- 190 |
| 2- 12c | 6- 48a | 2- 191 |
| 1- 15b | 1- 51 | 2- 192 |
| 3- 16 | 1- 52 | 2- 194 |
| 1- 19s | 2- 53a | 2- 212a |
| 1- 20a | 2- 54 | 2- 214 |
| 3- 22 | 4- 90a | 4- 221 |
| 1- 23a | 2- 111a | |

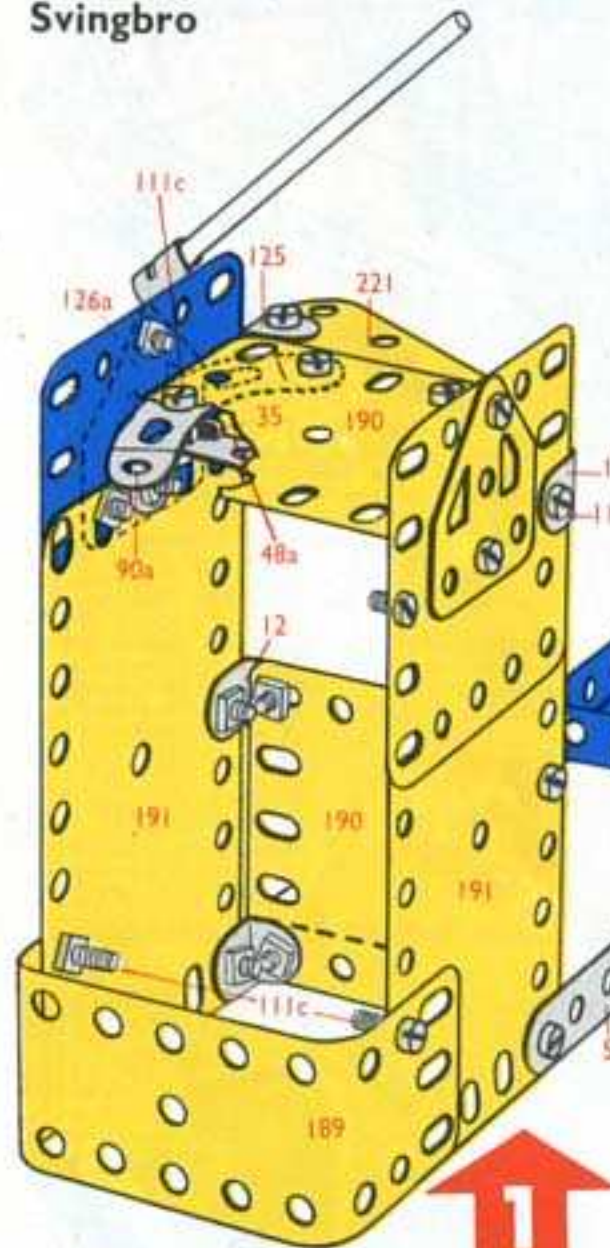
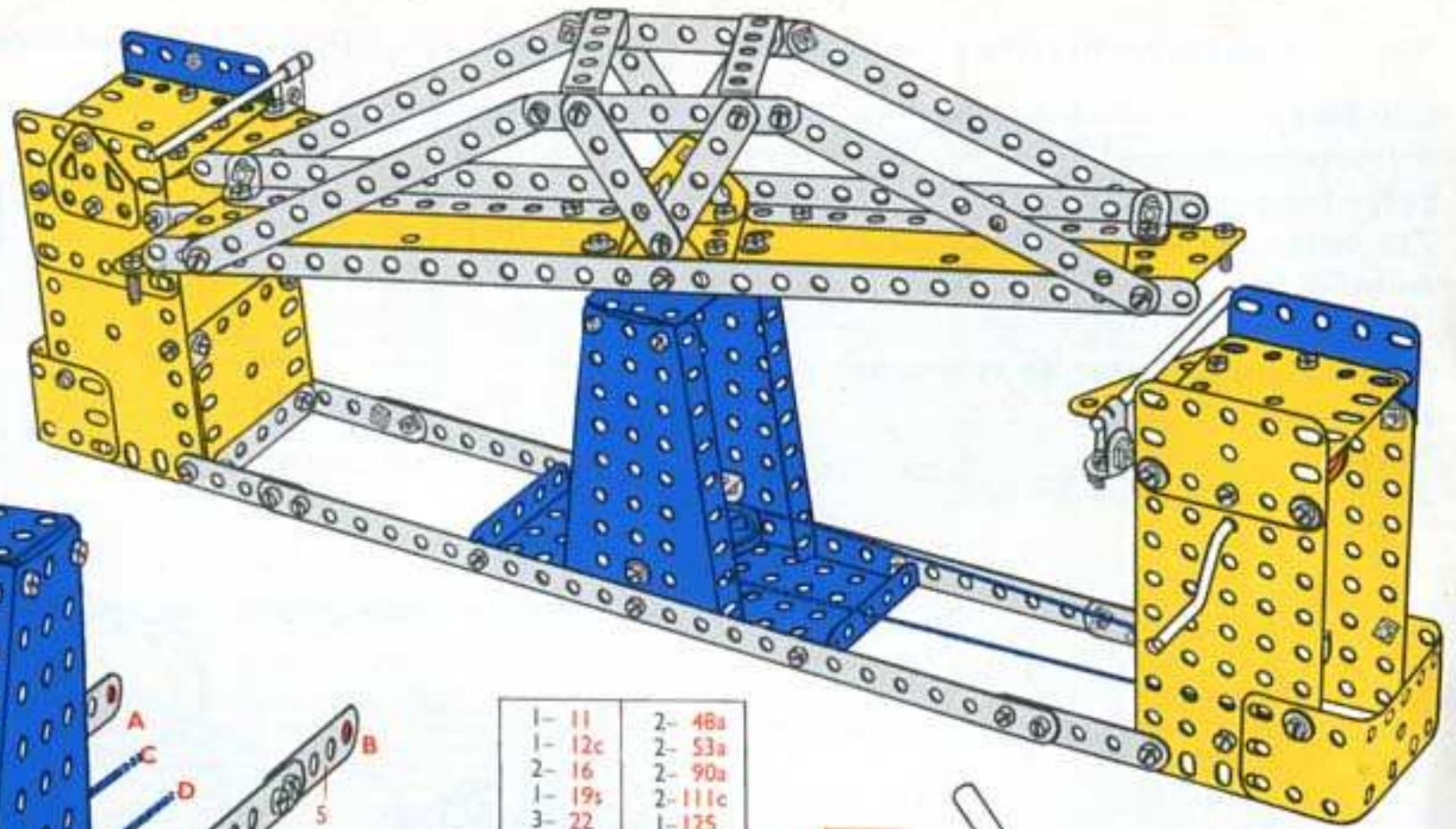

| | | |
|---------|---------|---------|
| 2- 1 | 44- 37b | 1- 125 |
| 5- 5 | 2- 38 | 2- 126a |
| 5- 12 | 1- 40 | 1- 189 |
| 1- 12c | 2- 48a | 3- 190 |
| 1- 15b | 1- 51 | 2- 191 |
| 1- 16 | 1- 52 | 1- 194 |
| 1- 20a | 2- 54 | 1- 212a |
| 2- 35 | 2- 90a | 1- 221 |
| 47- 37a | 4- 111c | |

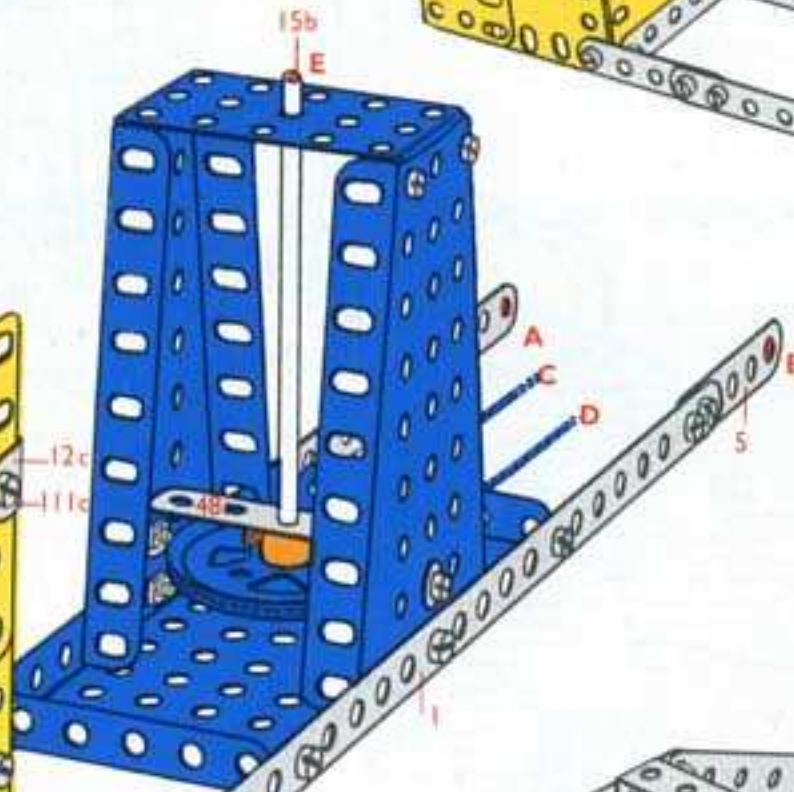

| | |
|---------|---------|
| 1- 11 | 2- 48a |
| 1- 12c | 2- 53a |
| 2- 16 | 2- 90a |
| 1- 19s | 2- 111c |
| 3- 22 | 1- 125 |
| 1- 23a | 1- 188 |
| 1- 24 | 1- 189 |
| 2- 27f | 1- 190 |
| 2- 35 | 1- 194 |
| 20- 37a | 1- 212a |
| 17- 37b | 1- 221 |
| 9- 38 | |

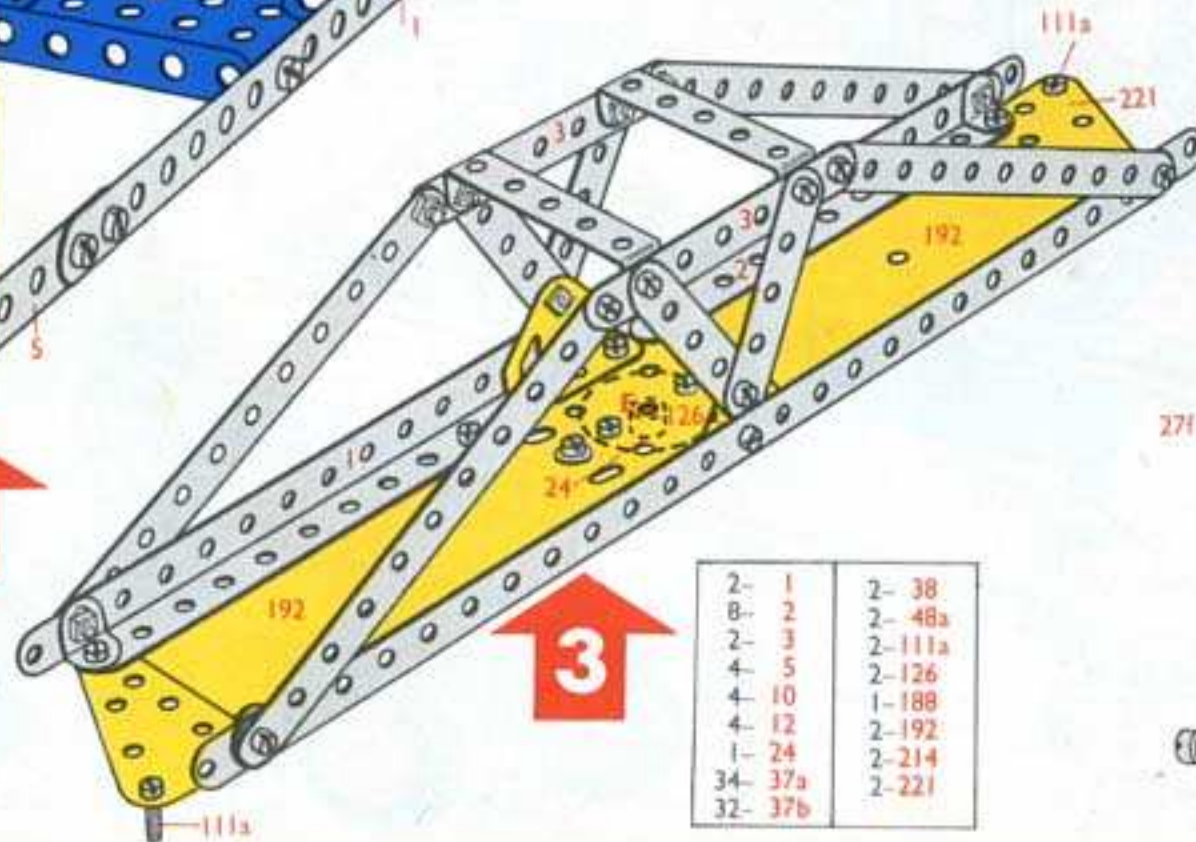

| | |
|---------|---------|
| 2- 1 | 2- 38 |
| 8- 2 | 2- 48a |
| 2- 3 | 2- 111a |
| 4- 5 | 2- 126 |
| 4- 10 | 1- 188 |
| 4- 12 | 2- 192 |
| 1- 24 | 2- 214 |
| 34- 37a | 2- 221 |
| 32- 37b | |

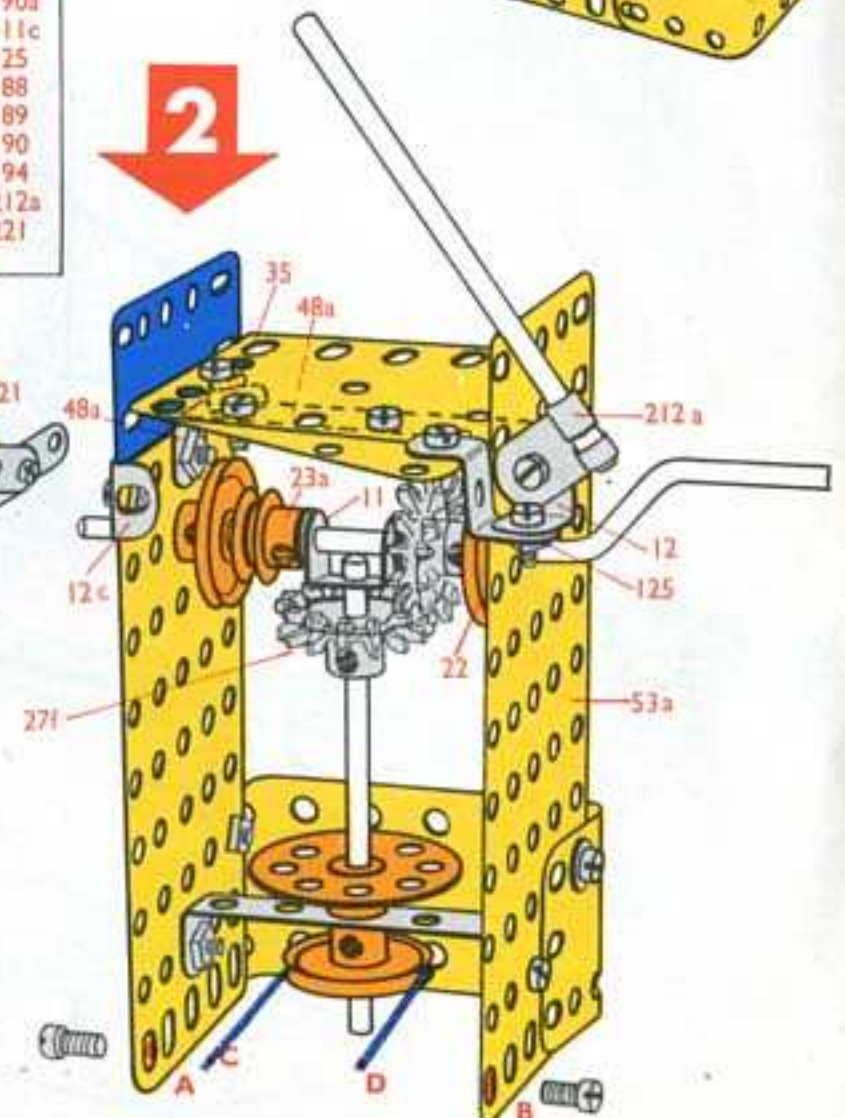

5.3

Heavy Goods Lorry
 Zware vrachtwagen
 Camion poids-lourd
 Autocarro per servizio pesante
 Schwerlastwagen
 Tung lastbil
 Camión de mercancías pesadas
 Camião de carga
 Tung lastebil

| | | | |
|-------|---------|---------|--------|
| 4- 1 | 2- 22 | 1- 52 | 2-189 |
| 8- 2 | 2- 22a | 2- 53a | 4-190 |
| 2- 3 | 1- 23 | 3- 90a | 2-191 |
| 9- 5 | 1- 23a | 1-111 | 2-192 |
| 4-10 | 1- 24 | 1-111a | 2-193 |
| 2-11 | 8- 35 | 6-111c | 1-193a |
| 1-11a | 107-37a | 2-125 | 2-194a |
| 6-12 | 93-37b | 2-126 | 2-212a |
| 1-12c | 14- 38 | 2-126a | 1-213 |
| 2-16 | 2-38d | 1-155 | 2-214 |
| 2-17 | 2- 48 | *1-186b | 4-215 |
| 2-18a | 6- 48a | 4-187 | 4-221 |
| 1-18b | 1- 51 | 2-188 | *1-M2 |

• Not included in set

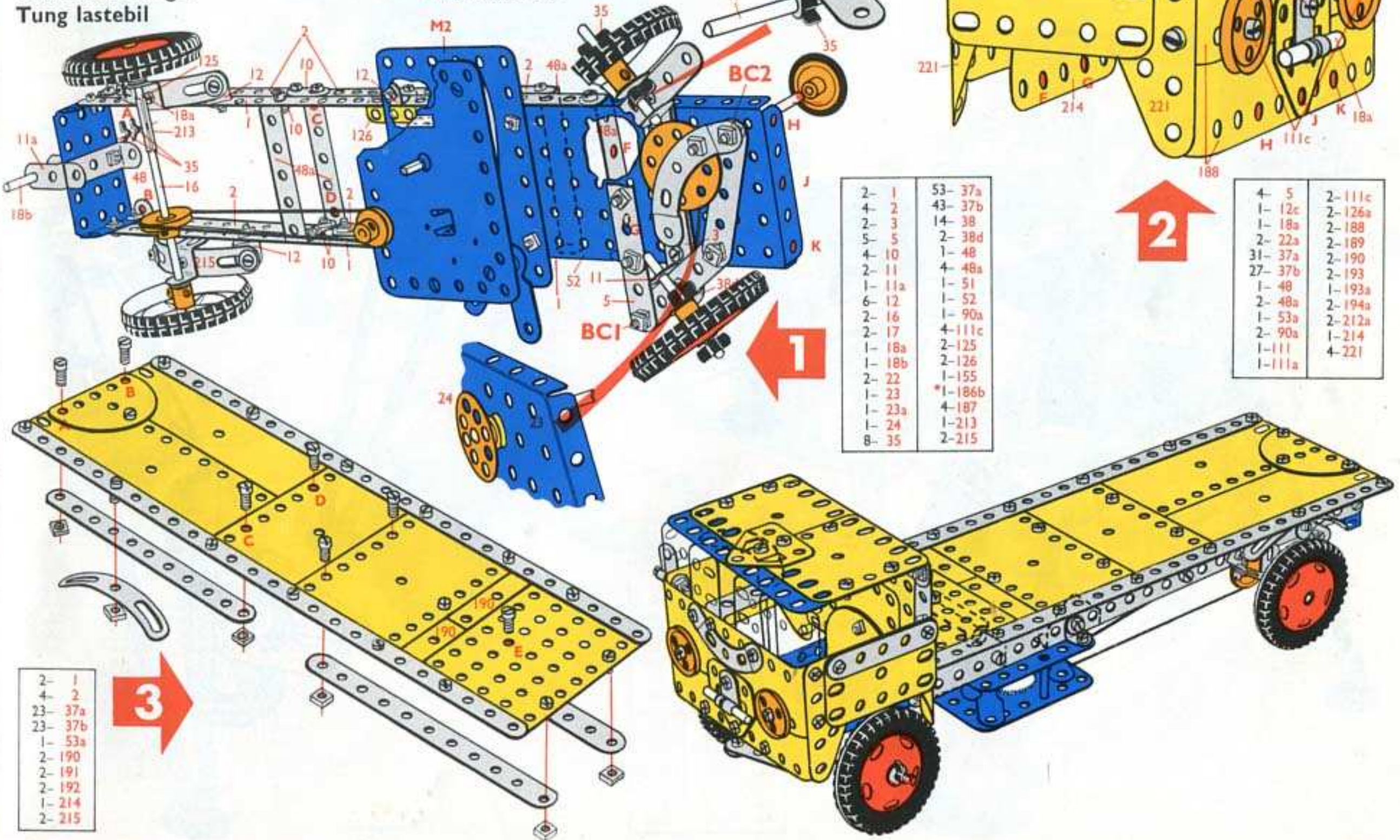

| | |
|-------|---------|
| 2- 1 | 53- 37a |
| 4- 2 | 43- 37b |
| 2- 3 | 14- 38 |
| 5- 5 | 2- 38d |
| 4-10 | 1- 48 |
| 2-11 | 4- 48a |
| 1-11a | 1- 51 |
| 6-12 | 1- 52 |
| 2-16 | 1- 90a |
| 2-17 | 4-111c |
| 1-18a | 2-125 |
| 1-18b | 2-126 |
| 1-23 | 1-155 |
| 1-23a | *1-186b |
| 1-24 | 4-187 |
| 8- 35 | 1-213 |
| | 2-215 |

| | |
|--------|--------|
| 4- 5 | 2-111c |
| 1-12c | 2-126a |
| 1-18a | 2-188 |
| 2-22a | 2-189 |
| 31-37a | 2-190 |
| 27-37b | 2-193 |
| 1- 48 | 1-193a |
| 2- 48a | 2-194a |
| 1- 53a | 2-212a |
| 2- 90a | 1-214 |
| 1-111 | 4-221 |
| 1-111a | |

| |
|---------|
| 2- 1 |
| 4- 2 |
| 23- 37a |
| 23- 37b |
| 1- 53a |
| 2-190 |
| 2-191 |
| 2-192 |
| 1-214 |
| 2-215 |



5.4

Moon Explorer
 Maanvoertuig
 Engin d'exploration lunaire
 Esploratore lunare
 Mondfahrzeug
 Månfarkost
 Explorador lunar
 Måneutforsker

| | | | |
|--------|----------|---------|---------|
| 4- 1 | 1- 18a | 2- 48 | 1- 176 |
| 8- 2 | 1- 18b | 6- 48a | 1- 186 |
| 2- 3 | 1- 19s | 1- 51 | 3- 187 |
| 7- 5 | 1- 20a | 1- 52 | 2- 188 |
| 4- 10 | 4- 22 | 2- 53a | 2- 192 |
| 2- 11 | 1- 22a | 2- 54 | 1- 212 |
| 1- 11a | 2- 24 | 2- 90a | 1- 212a |
| 10- 12 | 9- 35 | 1- 111a | 1- 213 |
| 4- 12c | 105- 37a | 6- 111c | 1- 215 |
| 1- 15b | 83- 37b | 1- 126 | 2- 221 |
| 2- 16 | 8- 38 | 3- 142c | |
| 2- 17 | 1- 40 | 1- 155 | |

| | |
|---------|---------|
| 1- 2 | 4- 38 |
| 7- 5 | 1- 40 |
| 1- 11a | 1- 48 |
| 2- 12 | 2- 90a |
| 1- 16 | 1- 111a |
| 1- 19s | 6- 111c |
| 1- 20a | 1- 176 |
| 1- 22 | 1- 186 |
| 5- 35 | 2- 188 |
| 40- 37a | 2- 221 |
| 18- 37b | |

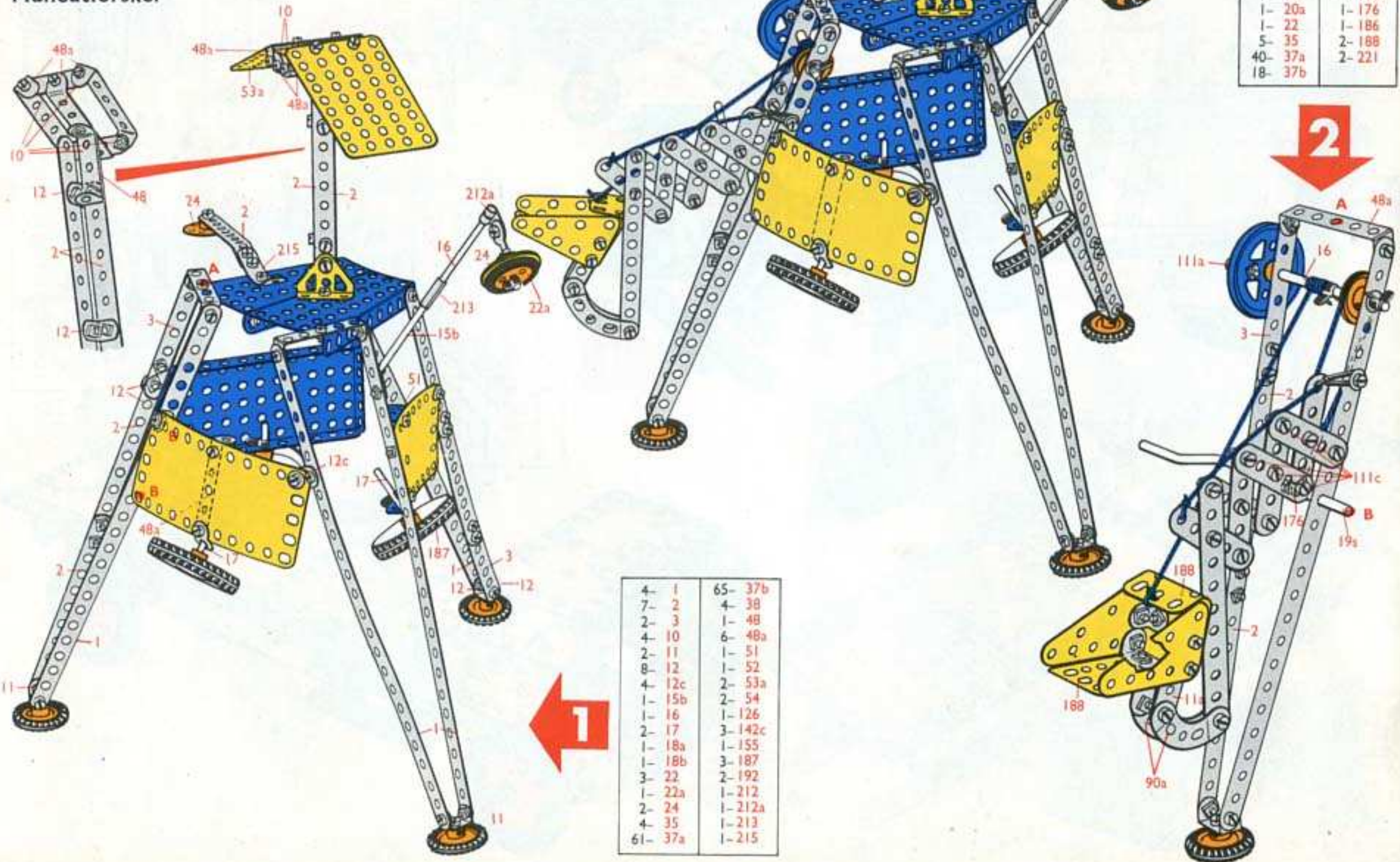

| | |
|---------|---------|
| 4- 1 | 65- 37b |
| 7- 2 | 4- 38 |
| 2- 3 | 1- 48 |
| 4- 10 | 6- 48a |
| 2- 11 | 1- 51 |
| 8- 12 | 1- 52 |
| 4- 12c | 2- 53a |
| 1- 15b | 2- 54 |
| 1- 16 | 1- 126 |
| 2- 17 | 3- 142c |
| 1- 18a | 1- 155 |
| 1- 18b | 3- 187 |
| 3- 22 | 2- 192 |
| 1- 22a | 1- 212 |
| 2- 24 | 1- 212a |
| 4- 35 | 1- 213 |
| 61- 37a | 1- 215 |

5.5

Car Ramp
 Auto-oprit
 Rampe pour voitures
 Rampa per auto
 Autorampe
 Bilbrygga
 Rampa para automóviles
 Rampa para automóveis
 Bilrampe

| | | | |
|--------|---------|---------|---------|
| 4- 1 | 1- 18b | 1- 40 | 4- 142c |
| 8- 2 | 1- 19s | 1- 48 | 1- 186 |
| 2- 3 | 1- 20a | 6- 48a | 2- 188 |
| 9- 5 | 4- 22 | 1- 52 | 2- 189 |
| 4- 10 | 2- 22a | 2- 53a | 2- 191 |
| 2- 11 | 2- 24 | 2- 54 | 2- 192 |
| 4- 12 | 7- 35 | 3- 90a | 1- 193 |
| 2- 12c | 74- 37a | 5- 111c | 2- 212a |
| 1- 15b | 66- 37b | 2- 125 | 2- 221 |
| 2- 16 | 14- 38 | 2- 126 | |
| 1- 17 | 2- 38d | 2- 126a | |

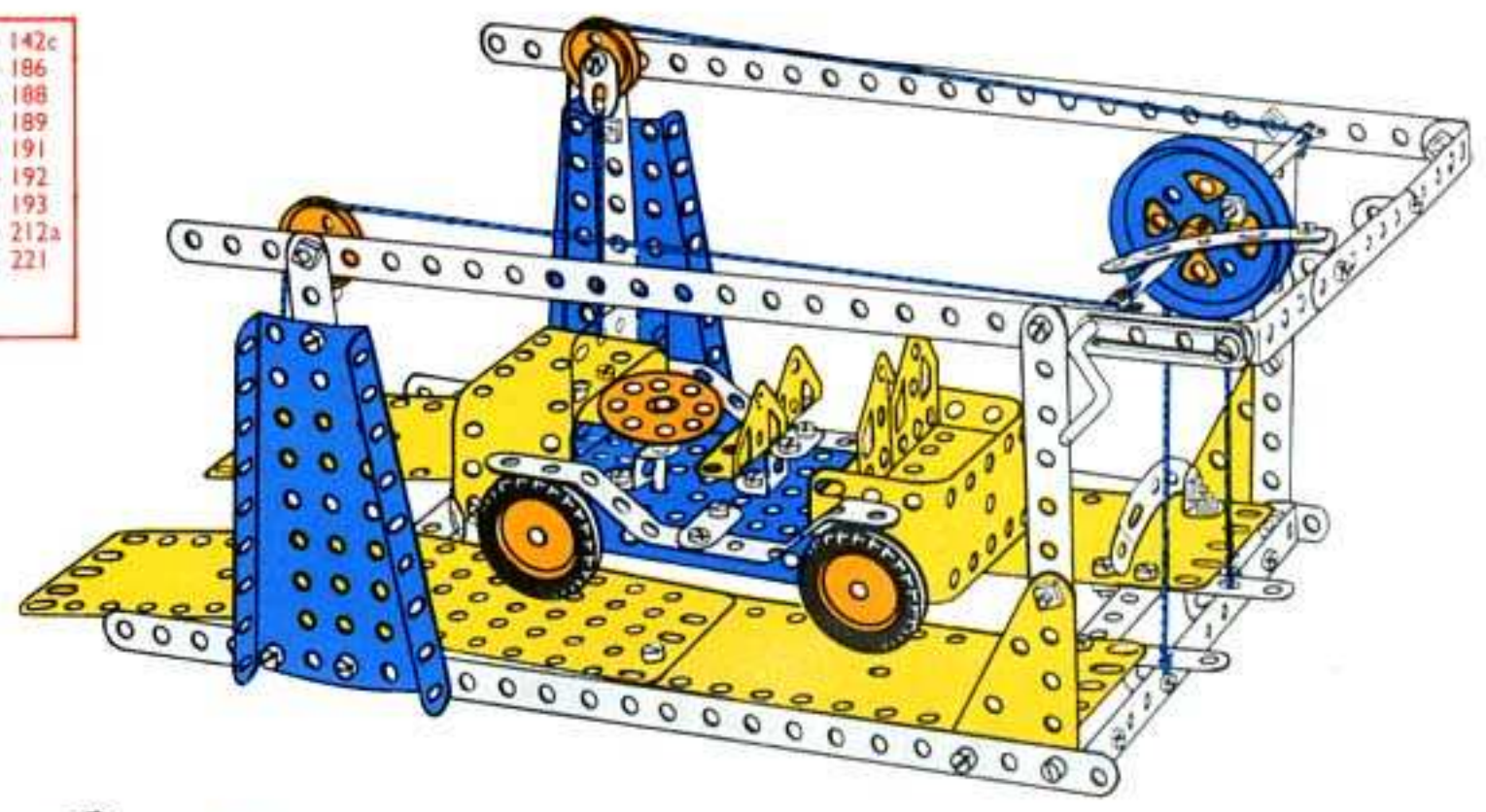

| | | |
|--------|---------|---------|
| 4- 1 | 1- 20a | 6- 48a |
| 6- 2 | 2- 22a | 2- 53a |
| 2- 3 | 1- 24 | 2- 54 |
| 9- 5 | 5- 35 | 3- 90a |
| 2- 10 | 56- 37a | 5- 111c |
| 1- 11 | 48- 37b | 1- 186 |
| 2- 12 | 4- 38 | 2- 191 |
| 1- 15b | 2- 38d | 2- 192 |
| 1- 18b | 1- 40 | 2- 212a |
| 1- 19s | 1- 48 | 2- 221 |

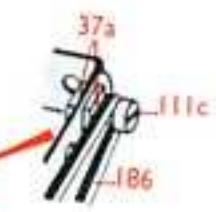
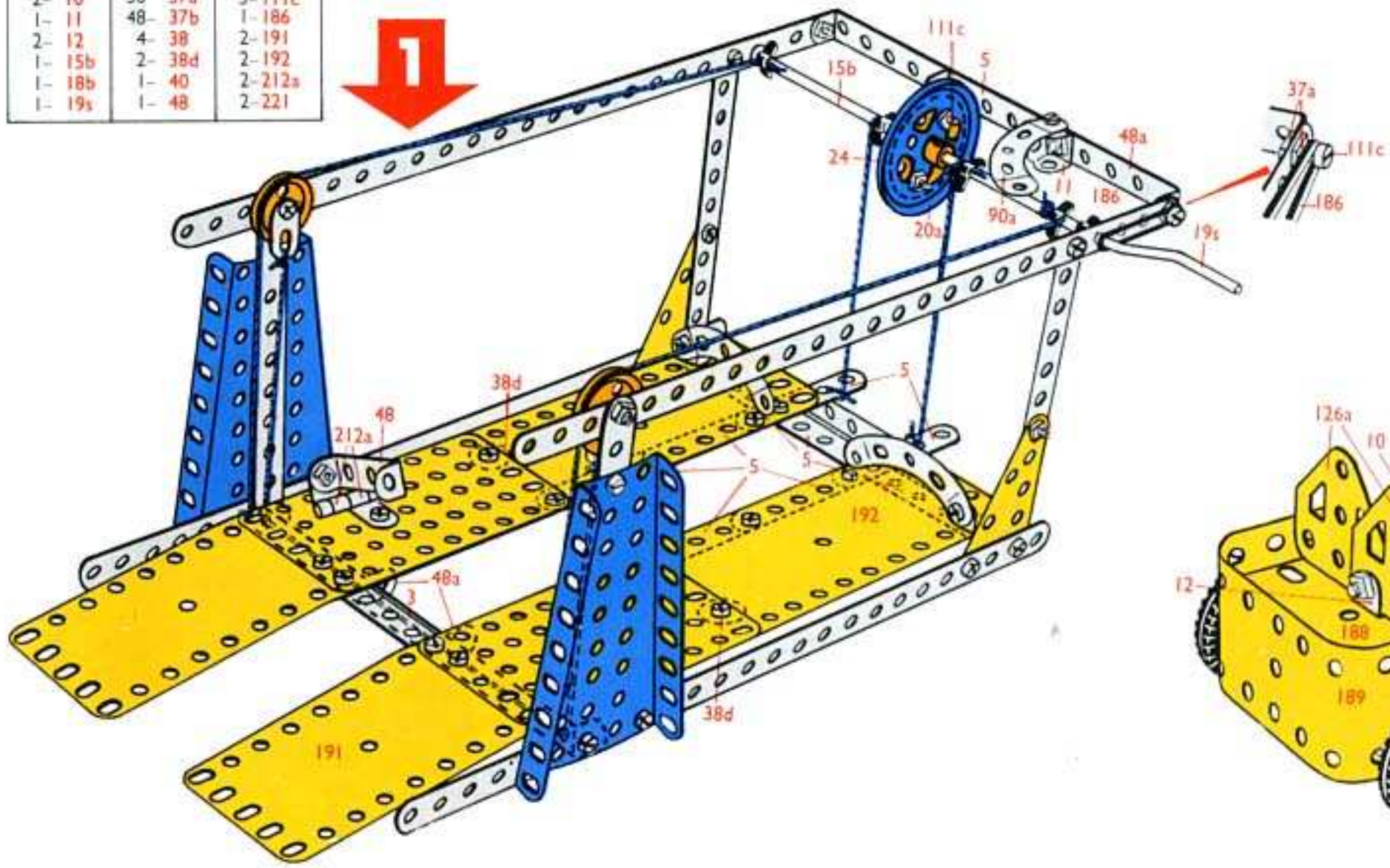

| | | |
|--------|---------|---------|
| 2- 2 | 4- 22 | 2- 125 |
| 2- 10 | 1- 24 | 2- 126 |
| 1- 11 | 2- 35 | 2- 126a |
| 2- 12 | 18- 37a | 4- 142c |
| 2- 12c | 18- 37b | 2- 188 |
| 2- 16 | 10- 38 | 2- 189 |
| 1- 17 | 1- 52 | 1- 193 |

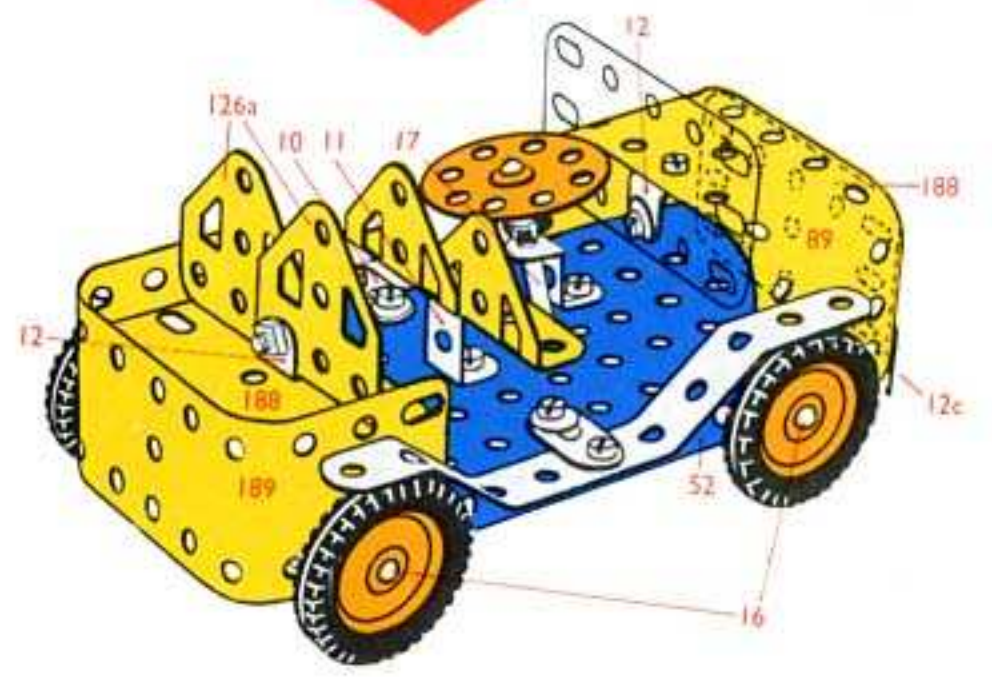

5.6

Jumbo Crane
 Jumbokraan
 Grue géante
 Gru Jumbo
 Jumbo Kran
 Tung lyftkran
 Grúa gigante
 Guindaste gigante
 Jumbo-kran

| | | | |
|--------|----------|---------|---------|
| 2- 1 | 1- 20a | 6- 48a | 1- 176 |
| 8- 2 | 4- 22 | 1- 51 | 4- 187 |
| 2- 3 | 1- 23 | 1- 52 | 2- 188 |
| 9- 5 | 1- 23a | 2- 54 | 2- 189 |
| 2- 10 | 2- 24 | 1- 57c | 1- 190 |
| 2- 11 | 2- 27f | 2- 90a | 2- 191 |
| 1- 11a | 10- 35 | 2- 111 | 2- 194 |
| 4- 12 | 104- 37a | 2- 111a | 1- 200 |
| 2- 15b | 88- 37b | 1- 111c | 1- 212 |
| 2- 16 | 15- 38 | 2- 126 | 2- 212a |
| 2- 17 | 2- 38d | 2- 126a | 2- 214 |
| 2- 18a | 1- 40 | 1- 142c | 4- 221 |
| 1- 19s | 2- 48 | 2- 155 | |

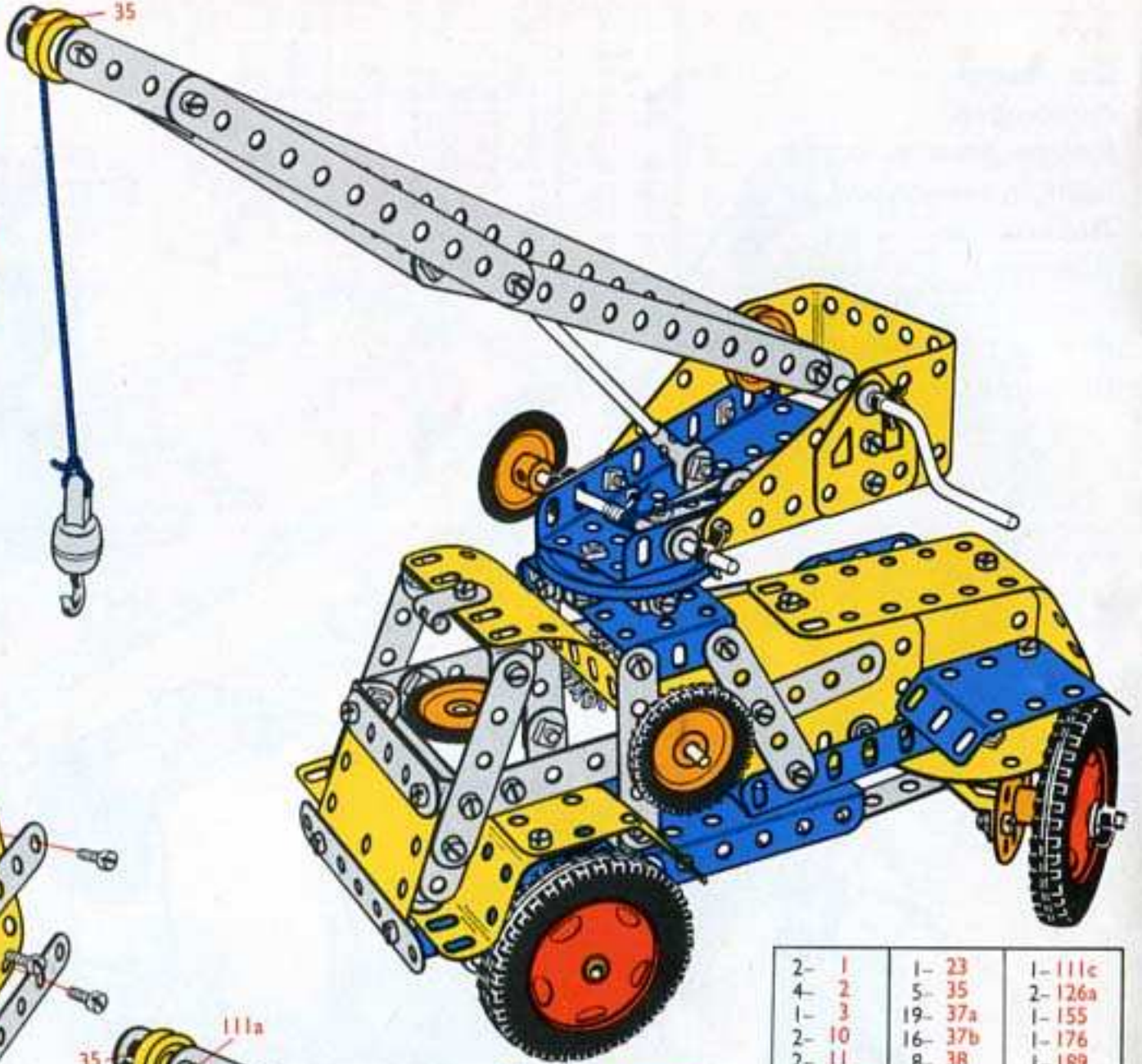

| | | |
|--------|---------|---------|
| 2- 1 | 1- 23 | 1- 111c |
| 4- 2 | 5- 35 | 2- 126a |
| 1- 3 | 19- 37a | 1- 155 |
| 2- 10 | 16- 37b | 1- 176 |
| 2- 11 | 8- 38 | 1- 189 |
| 1- 15b | 1- 40 | 1- 212 |
| 1- 16 | 1- 48 | 1- 212a |
| 1- 19s | 1- 54 | 2- 221 |
| 1- 20a | 1- 57c | |
| 2- 22 | 1- 111a | |

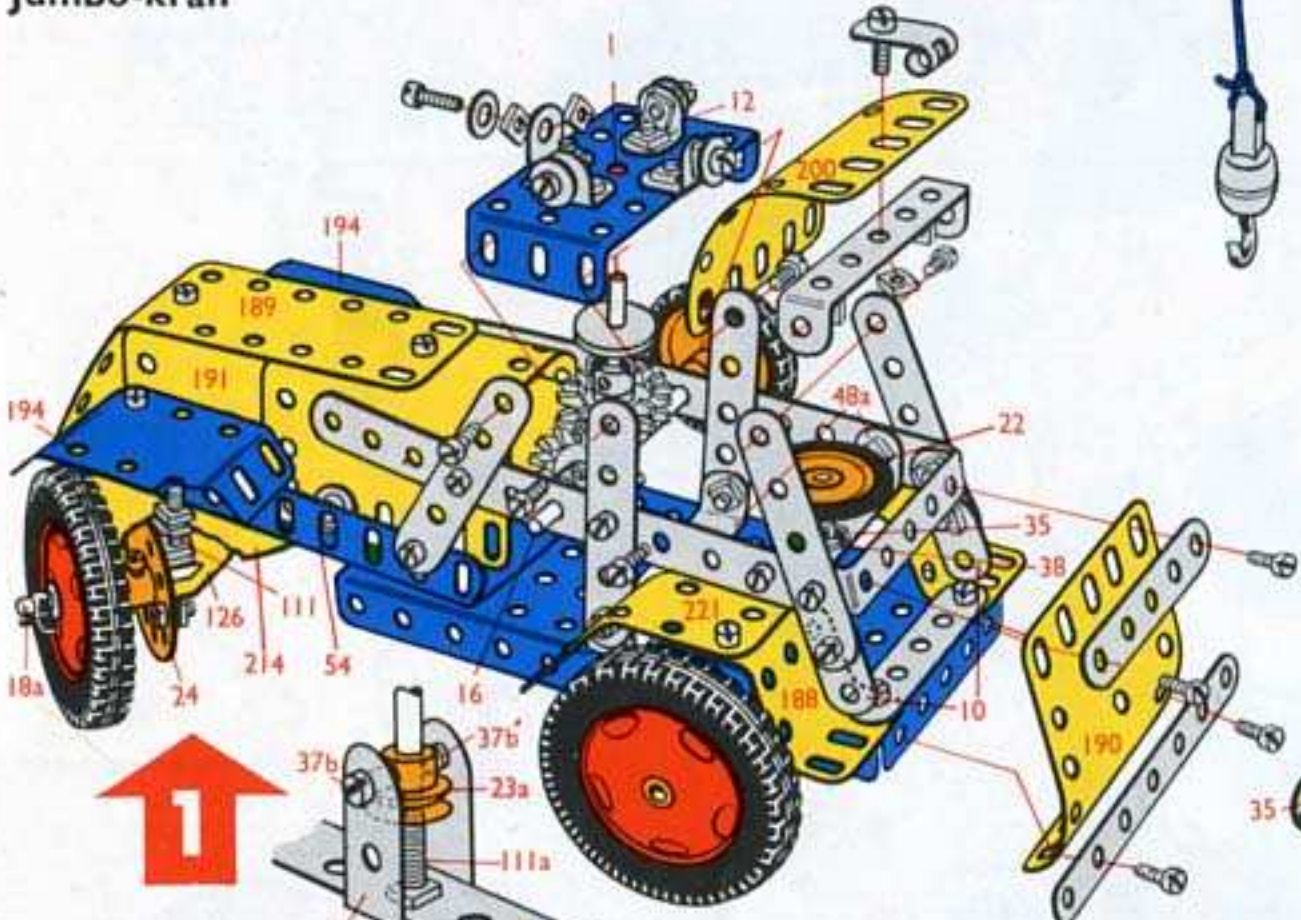

| | |
|---------|---------|
| 2- 2 | 1- 51 |
| 1- 3 | 1- 52 |
| 8- 5 | 1- 54 |
| 2- 10 | 2- 90a |
| 4- 12 | 2- 111 |
| 1- 15b | 2- 126 |
| 1- 16 | 1- 142c |
| 2- 17 | 1- 155 |
| 2- 18a | 4- 187 |
| 2- 22 | 2- 188 |
| 2- 24 | 1- 189 |
| 2- 27f | 1- 190 |
| 5- 35 | 2- 191 |
| 72- 37a | 2- 194 |
| 62- 37b | 1- 200 |
| 7- 38 | 1- 212a |
| 2- 38d | 2- 214 |
| 1- 48 | 2- 221 |
| 4- 48a | |

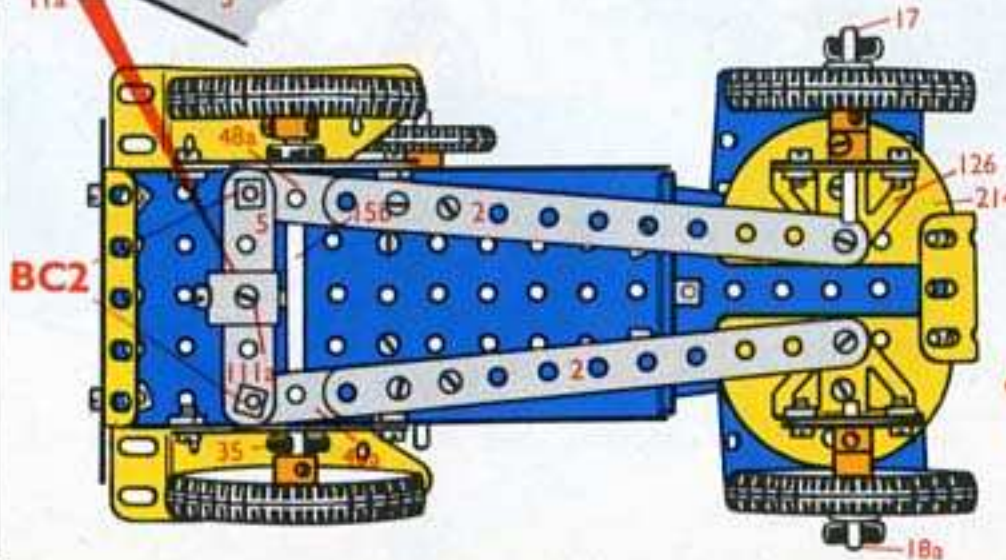

| |
|---------|
| 2- 2 |
| 1- 5 |
| 1- 11a |
| 1- 23a |
| 13- 37a |
| 10- 37b |
| 2- 48a |
| 1- 111a |

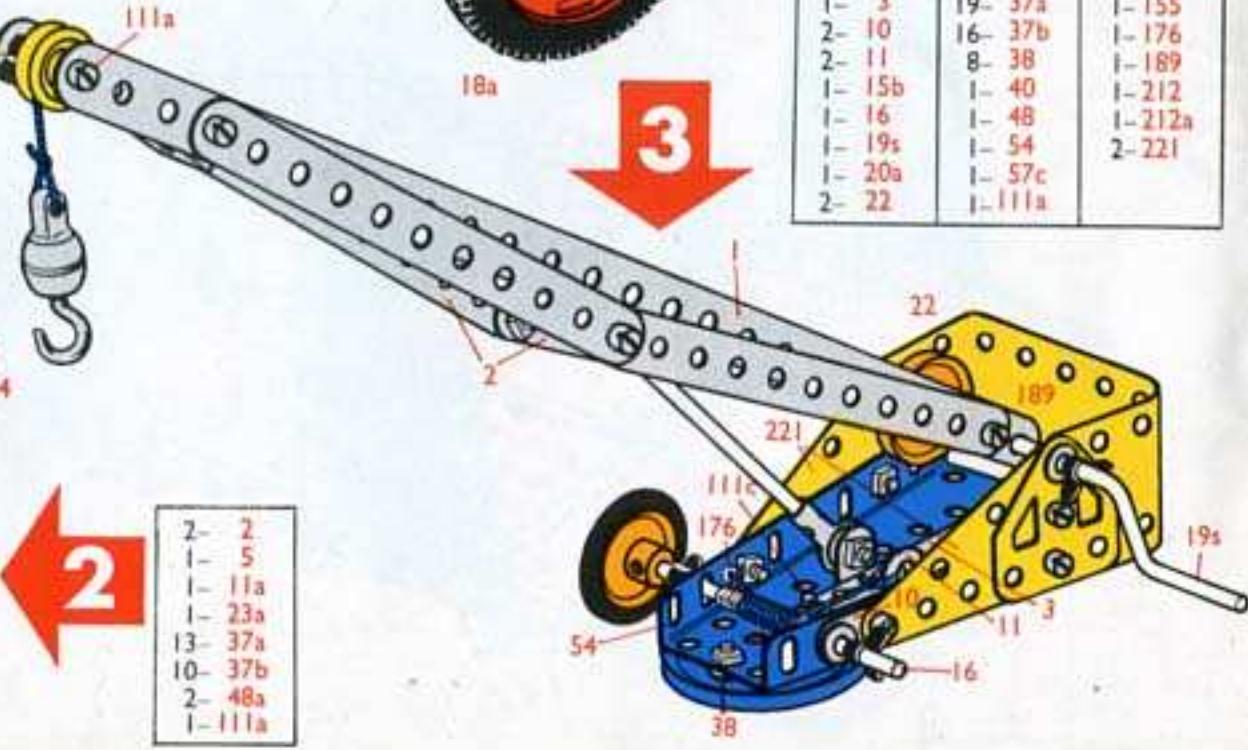

5.7

Loading Shovel
Lepelschop
Pelle de chargement
Motopala
Schaufellader
Skoplastare
Pala cargadora
Pá de cargar
Lasteskuffe

| | | | |
|--------|---------|---------|---------|
| 8- 2 | 1- 19s | 1- 52 | 3- 190 |
| 2- 3 | 4- 22 | 2- 53a | 2- 191 |
| 9- 5 | 2- 24 | 2- 54 | 1- 199 |
| 1- 10 | 2- 27f | 4- 90a | 1- 200 |
| 2- 11 | 16- 35 | 4- 111c | 1- 212 |
| 1- 11a | 95- 37a | 2- 125 | 2- 212a |
| 10- 12 | 93- 37b | 2- 126 | 1- 213 |
| 4- 12c | 12- 38 | 2- 126a | 2- 214 |
| 2- 15b | 2- 38d | 1- 155 | 4- 221 |
| 4- 16 | 1- 40 | 1- 176 | |
| 2- 17 | 1- 48 | 1- 186 | |
| 2- 18a | 6- 48a | 4- 187 | |
| 1- 18b | 1- 51 | 1- 188 | |

| | | | |
|--------|---------|---------|---------|
| 2- 2 | 2- 22 | 1- 51 | 1- 188 |
| 2- 3 | 1- 24 | 1- 52 | 3- 190 |
| 2- 5 | 2- 27f | 2- 54 | 2- 191 |
| 1- 11a | 3- 35 | 2- 90a | 1- 200 |
| 4- 12c | 55- 37a | 2- 111c | 1- 212 |
| 2- 16 | 53- 37b | 2- 126 | 2- 212a |
| 1- 18a | 4- 38 | 2- 126a | 2- 214 |
| 1- 18b | 2- 38d | 1- 155 | |
| 1- 19s | 4- 48a | 1- 176 | |

| | |
|---------|---------|
| 5- 5 | 9- 37b |
| 2- 11 | 4- 38 |
| 2- 16 | 1- 48a |
| 2- 17 | 1- 111c |
| 1- 24 | 4- 187 |
| 7- 35 | 1- 199 |
| 10- 37a | 1- 213 |

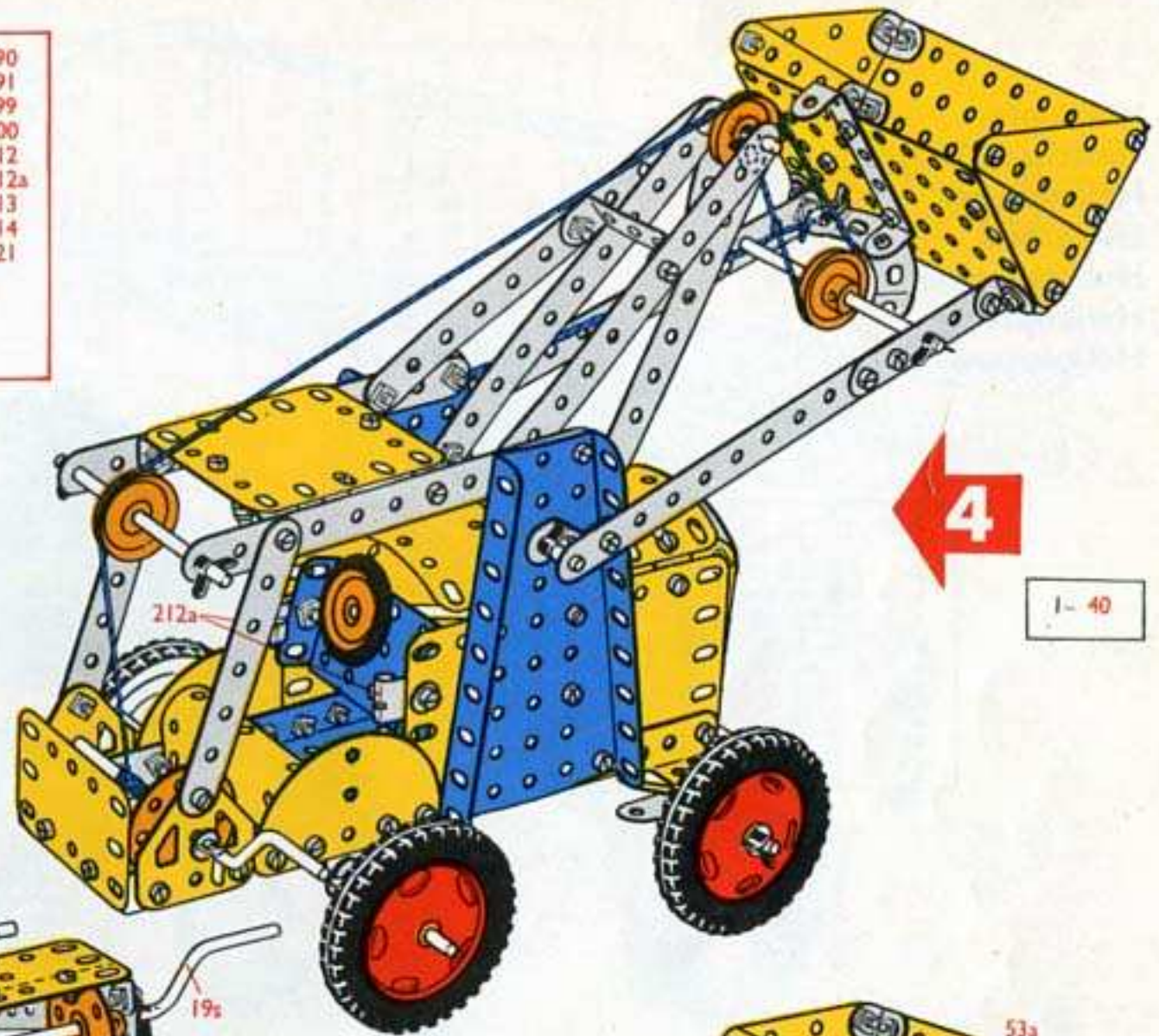

1- 40

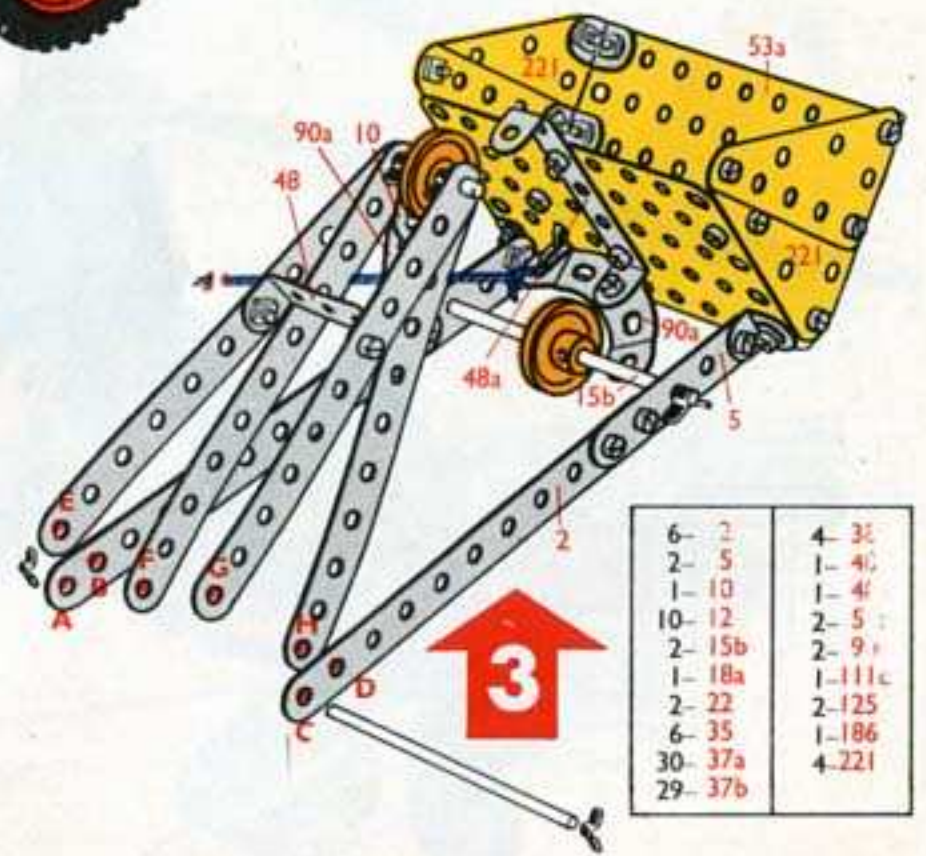
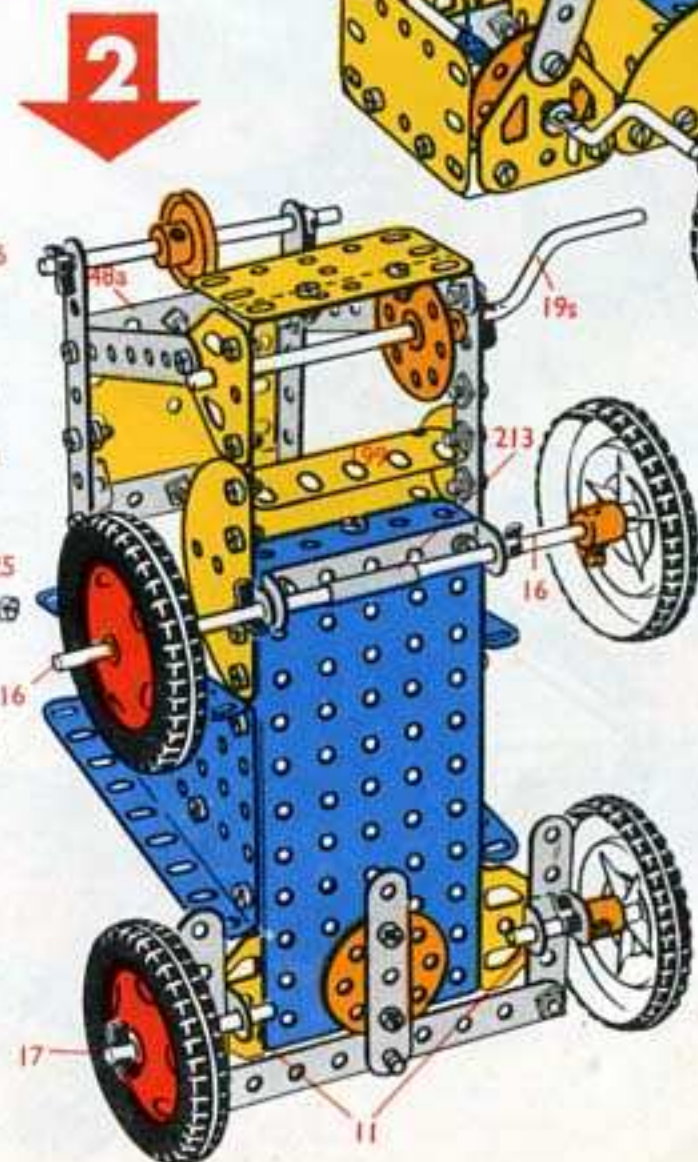
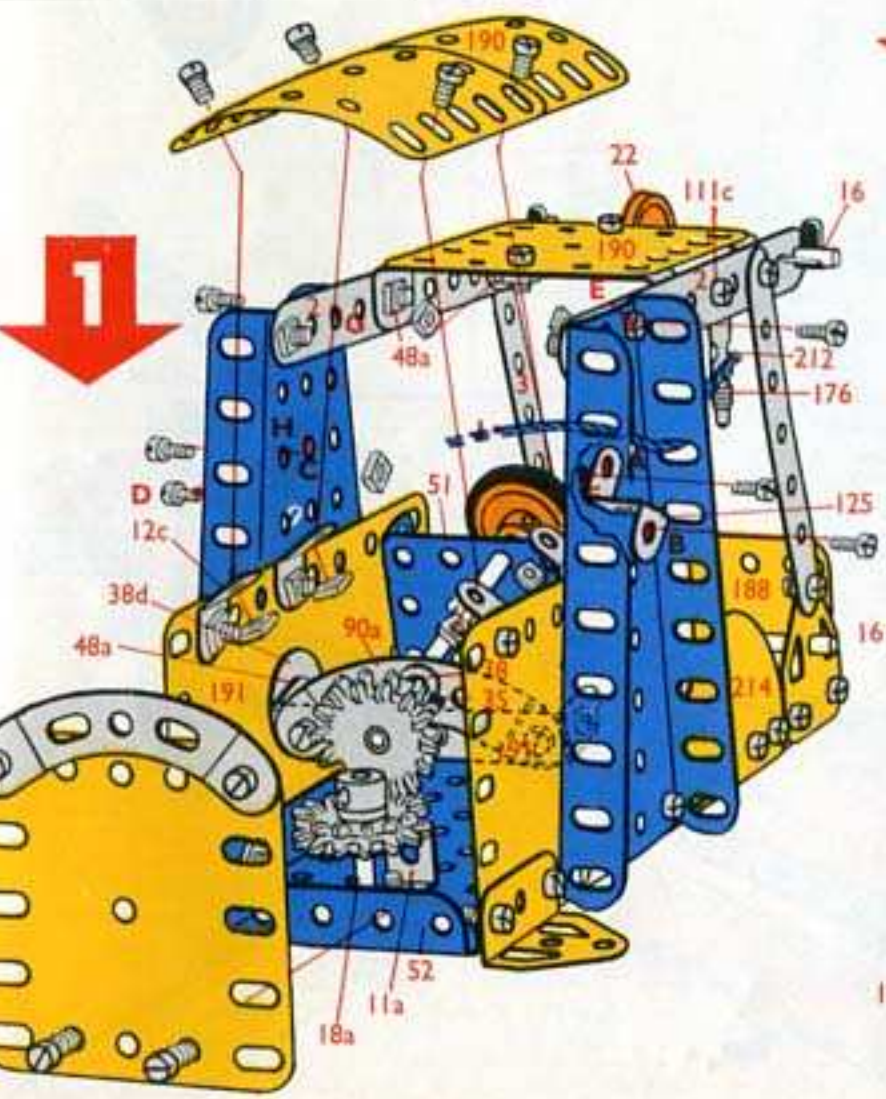

| | |
|---------|---------|
| 6- 2 | 4- 38 |
| 2- 5 | 1- 40 |
| 1- 10 | 1- 48 |
| 10- 12 | 2- 51 |
| 2- 15b | 2- 91 |
| 1- 18a | 1- 111c |
| 2- 22 | 2- 125 |
| 6- 35 | 1- 186 |
| 30- 37a | 4- 221 |
| 29- 37b | |

5.8

Helicopter
 Hefschroefvliegtuig
 Hélicoptère
 Elicottero
 Hubschrauber
 Helikopter
 Helicóptero

| | | | |
|-------|---------|--------|--------|
| 4- 1 | 4- 22 | 1- 51 | 1-191 |
| 8- 2 | 2- 22a | 2- 54 | 2-192 |
| 2- 3 | 1- 23 | 3- 90a | 2-193 |
| 9- 5 | 2- 24 | 2-111 | 1-193a |
| 1-10 | 2- 27f | 2-125 | 1-199 |
| 1-11a | 1- 35 | 2-126 | 1-200 |
| 5-12 | 94- 37a | 2-126a | 1-213 |
| 4-12c | 91- 37b | 2-142c | 2-214 |
| 2-15b | 11- 38 | 2-155 | 4-215 |
| 1-16 | 1- 38d | 1-186 | 4-221 |
| 1-18a | 1- 40 | 2-188 | |
| 2-19b | 1- 48 | 2-189 | |
| 1-20a | 4- 48a | 3-190 | |

| | | | |
|-------|---------|--------|--------|
| 1- 1 | 1- 20a | 1- 48 | 1-186 |
| 1- 2 | 3- 22 | 4- 48a | 2-188 |
| 2- 3 | 2- 22a | 1- 51 | 3-190 |
| 4- 5 | 1- 23 | 2- 54 | 2-193 |
| 1-11a | 2- 27f | 3- 90a | 1-193a |
| 3-12 | 1- 35 | 1-111 | 1-200 |
| 4-12c | 54- 37a | 2-125 | 1-213 |
| 2-15b | 52- 37b | 2-126 | 2-214 |
| 1-16 | 7- 38 | 2-126a | 3-215 |
| 1-18a | 1- 38d | 2-142c | 4-221 |
| 2-19b | 1- 40 | 2-155 | |

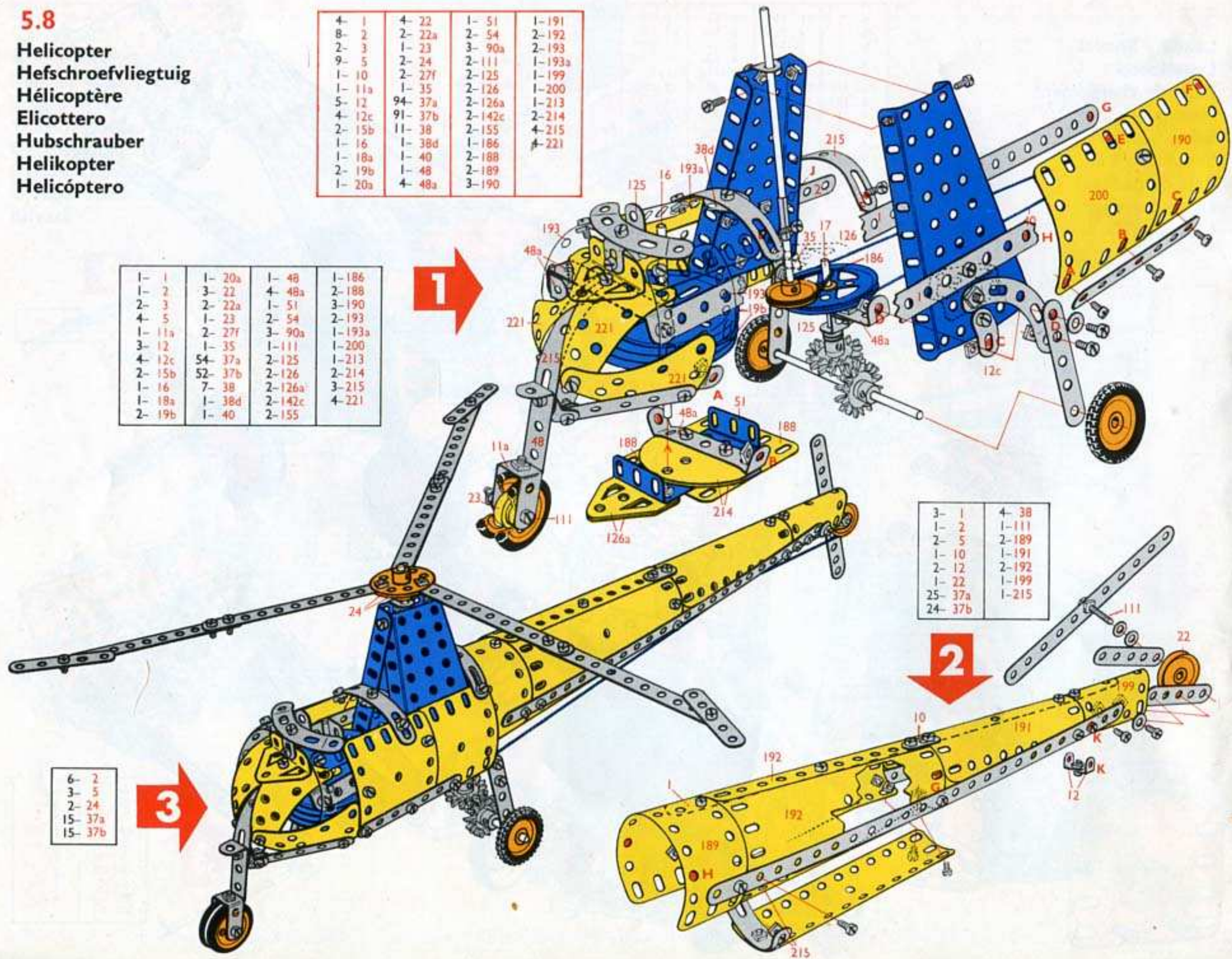

| | |
|---------|-------|
| 3- 1 | 4- 38 |
| 1- 2 | 1-111 |
| 2- 5 | 2-189 |
| 1-10 | 1-191 |
| 2-12 | 2-192 |
| 1-22 | 1-199 |
| 25- 37a | 1-215 |
| 24- 37b | |

| |
|---------|
| 6- 2 |
| 3- 5 |
| 2- 24 |
| 15- 37a |
| 15- 37b |

5.9

Construction Crane with Grab
Constructiekraan met grijper
Grue de construction avec benne preneuse
Gru per cantiere con benna
Baukran mit Greifer
Byggnadskran med gripanordning
Grúa para obras, con bivalva
Guindaste de construção com garras
Kran med grabb

| | | | |
|--------|----------|---------|-----------|
| 4- 1 | 1- 19s | 2- 38d | 2- 126a |
| 8- 2 | 1- 20a | 1- 40 | 1- 176 |
| 2- 3 | 4- 22 | 2- 48 | 1- 186a |
| 9- 5 | 2- 22a | 6- 48a | * 1- 186b |
| 4- 10 | 1- 23 | 1- 51 | 2- 187 |
| 2- 11 | * 1- 23a | 1- 52 | 2- 188 |
| 1- 11a | 1- 23a | 2- 53a | 2- 189 |
| 10- 12 | 2- 24 | 2- 54 | 1- 190 |
| 1- 12c | 2- 27f | 4- 90a | 1- 200 |
| 2- 15b | 16- 35 | 2- 111 | 2- 212a |
| 4- 16 | 103- 37a | 2- 111a | 1- 213 |
| 2- 17 | 93- 37b | 2- 111c | 2- 221 |
| 2- 19b | 14- 38 | 2- 126 | * 1- M5 |

* Not included in set No. 5

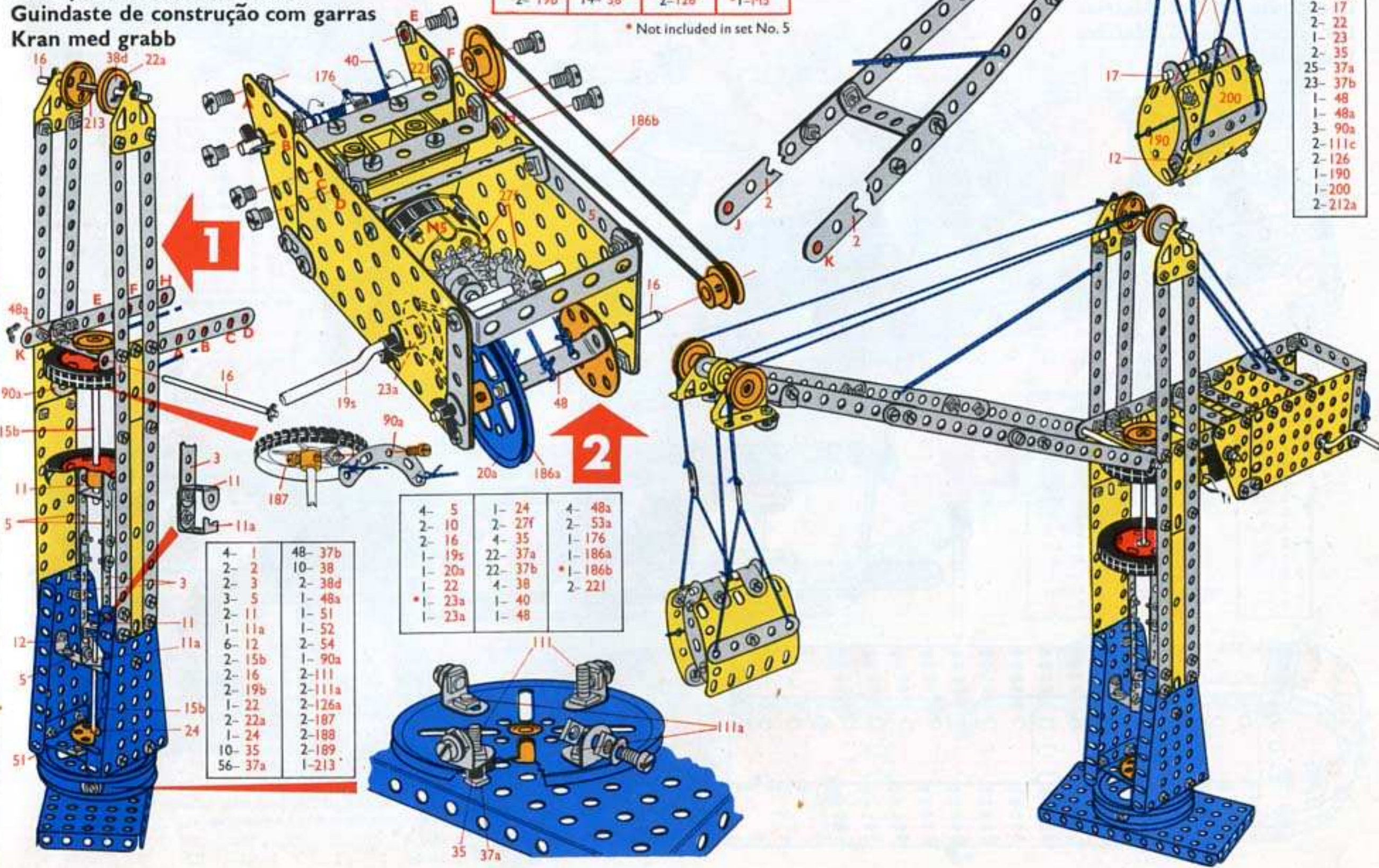

| | |
|---------|---------|
| 4- 1 | 48- 37b |
| 2- 2 | 10- 38 |
| 2- 3 | 2- 38d |
| 3- 5 | 1- 48a |
| 2- 11 | 1- 51 |
| 1- 11a | 1- 52 |
| 6- 12 | 2- 54 |
| 2- 15b | 1- 90a |
| 2- 16 | 2- 111 |
| 2- 19b | 2- 111a |
| 1- 22 | 2- 126a |
| 2- 22a | 2- 187 |
| 1- 24 | 2- 188 |
| 10- 35 | 2- 189 |
| 56- 37a | 1- 213 |

| | | |
|----------|---------|-----------|
| 4- 5 | 1- 24 | 4- 48a |
| 2- 10 | 2- 27f | 2- 53a |
| 2- 16 | 4- 35 | 1- 176 |
| 1- 19s | 22- 37a | 1- 186a |
| 1- 20a | 22- 37b | * 1- 186b |
| 1- 22 | 4- 38 | 2- 221 |
| * 1- 23a | 1- 40 | |
| 1- 23a | 1- 48 | |

| |
|---------|
| 6- 2 |
| 2- 5 |
| 2- 10 |
| 4- 12 |
| 1- 12c |
| 2- 17 |
| 2- 22 |
| 1- 23 |
| 2- 35 |
| 25- 37a |
| 23- 37b |
| 1- 48 |
| 1- 48a |
| 3- 90a |
| 2- 111c |
| 2- 126 |
| 1- 190 |
| 1- 200 |
| 2- 212a |

5.10

Diesel Electric Locomotive
Diesel-elektrische locomotief
Locomotive électrique Diesel
Locomotore diesel/eletrico
Elektro-Diesel-Lokomotive
Dieselektriskt lok
Locomotrora diesel eléctrica
Locomotiva Diesel eléctrica
Diesel-lokomotiv

| | | | |
|-----|-----|-----|------|
| 2- | 1 | 32- | 37b |
| 2- | 2 | 1- | 38 |
| 4- | 5 | 2- | 38d |
| 4- | 10 | 2- | 48a |
| 1- | 11a | 1- | 51 |
| 1- | 12 | 1- | 52 |
| 1- | 16 | 3- | 111c |
| 1- | 23a | 2- | 126 |
| 1- | 24 | 2- | 126a |
| 2- | 35 | 1- | 212 |
| 40- | 37a | | |

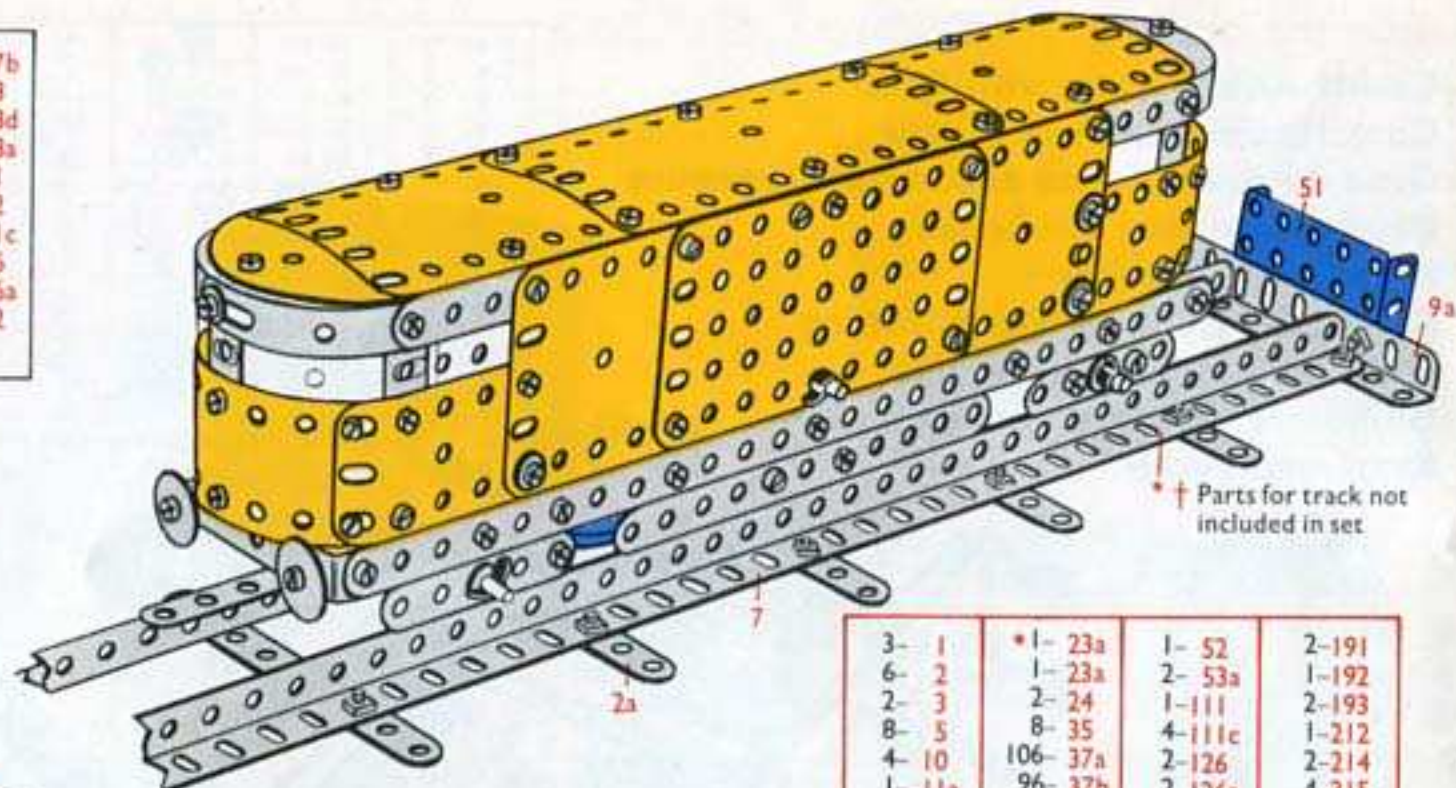

| | | | | | | | |
|----|-----|------|-----|----|------|-----|-----|
| 3- | 1 | *1- | 23a | 1- | 52 | 2- | 191 |
| 6- | 2 | 1- | 23a | 2- | 53a | 1- | 192 |
| 2- | 3 | 2- | 24 | 1- | 111 | 2- | 193 |
| 8- | 5 | 8- | 35 | 4- | 111c | 1- | 212 |
| 4- | 10 | 106- | 37a | 2- | 126 | 2- | 214 |
| 1- | 11a | 96- | 37b | 2- | 126a | 4- | 215 |
| 7- | 12 | 13- | 38 | 1- | 186 | *1- | M5 |
| 4- | 16 | 2- | 38d | 2- | 188 | | |
| 1- | 20a | 6- | 48a | 2- | 189 | | |
| 4- | 22 | 1- | 51 | 4- | 190 | | |

Not included in set No. 5

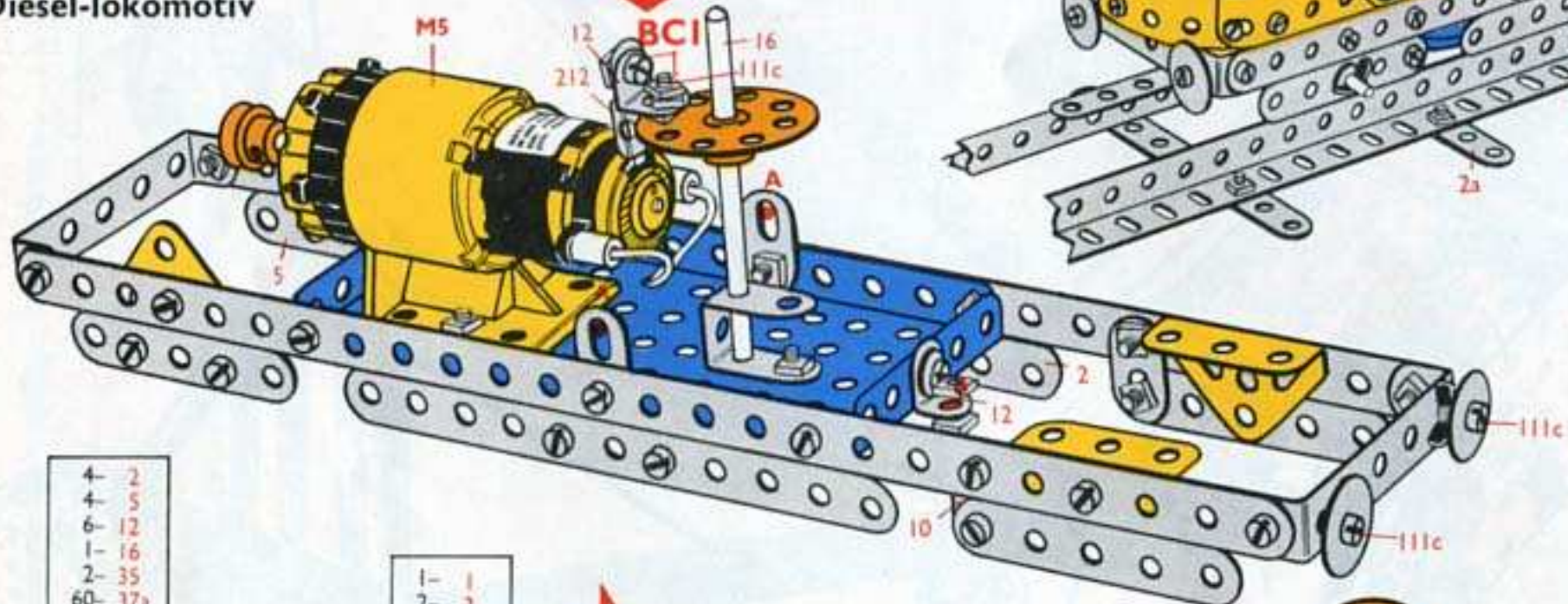

| | |
|-----|-----|
| 4- | 2 |
| 4- | 5 |
| 6- | 12 |
| 1- | 16 |
| 2- | 35 |
| 60- | 37a |
| 60- | 37b |
| 8- | 38 |
| 4- | 48a |
| 2- | 53a |
| 2- | 188 |
| 2- | 189 |
| 4- | 190 |
| 2- | 191 |
| 1- | 192 |
| 2- | 193 |
| 2- | 214 |
| 4- | 215 |

| | |
|----|------|
| 1- | 1 |
| 2- | 3 |
| 2- | 16 |
| 1- | 20a |
| 4- | 22 |
| 1- | 23a |
| 1- | 24 |
| 4- | 35 |
| 6- | 37a |
| 3- | 37b |
| 4- | 38 |
| 1- | 111 |
| 1- | 111c |
| 1- | 186 |

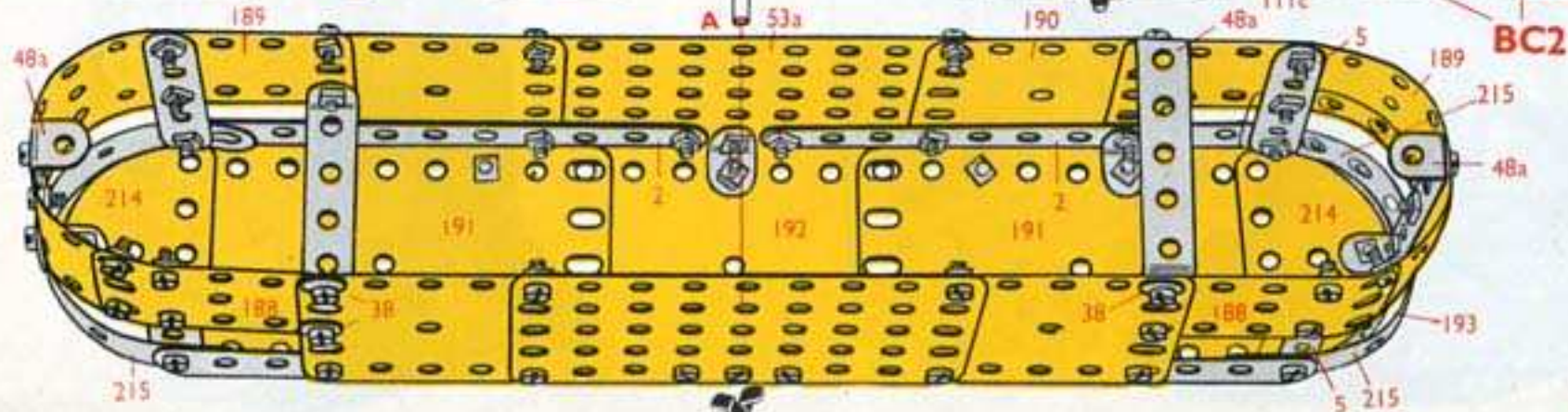
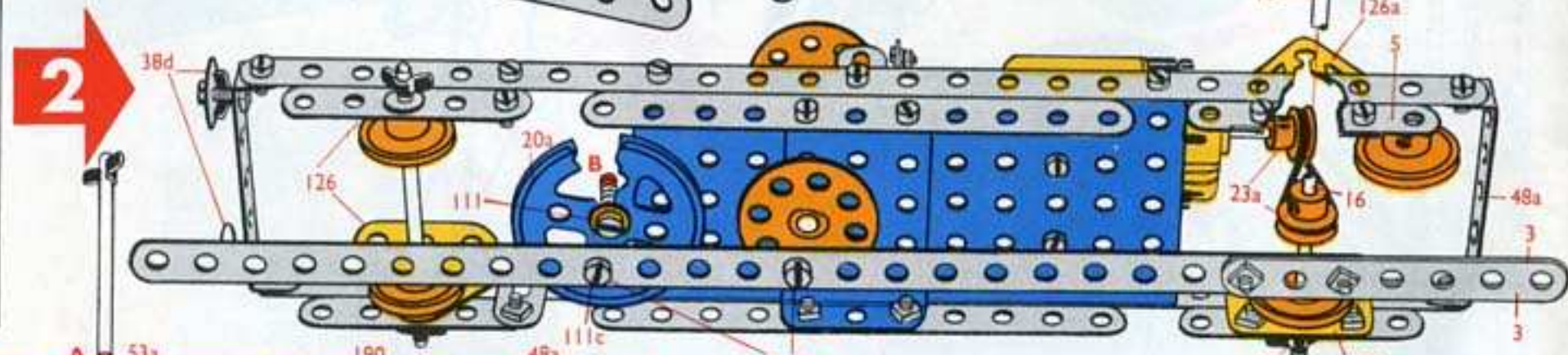

Parts for 24 1/2" (62cm) Track not included in set.
 Onderdelen voor 62cm, spoor zijn niet inbegrepen bij de set.
 Les pièces pour le circuit de 24 1/2" (62cm) ne sont pas comprises.
 I pezzi per il cingolo di 62cm. non sono inclusi nella serie.
 Teile für 62cm Spur sind in diesem Satz nicht enthalten.
 Delar til 62cm spår ingår ej i satsen.
 Las piezas para vía de 62cm (24 1/2") no van incluidas en el juego.
 Peças para vias de 62cm (24 1/2") nao estao incluidas no jogo.
 Deler til 62cm spor er ikke inkludert i settet.

| | | | | | | |
|------------|----|---|----|-----|-----|----|
| Part No. | 2a | 7 | 9a | 37a | 37b | 51 |
| † Quantity | 7 | 2 | 2 | 22 | 22 | 2 |

5.11.

Traction Engine
 Tractiewagen
 Moteur de traction
 Motore di trazione
 Zugmaschine
 Lokomobil
 Máquina de tracción
 Motor de tracção

| | | | |
|--------|---------|--------|---------|
| B- 2 | 4- 22 | 2- 48 | *1-186a |
| 2- 3 | 2- 22a | 6- 48a | 1-186a |
| 8- 5 | 1- 23 | 1- 52 | 2-187 |
| 2- 11 | *1- 23a | 2- 53a | 2-188 |
| 1- 11a | 1- 23a | 1-111 | 3-190 |
| 10-12 | 2- 24 | 2-111c | 2-191 |
| 4- 12c | 2- 27f | 2-125 | 2-192 |
| 2- 15b | 7- 35 | 2-126 | 1-194a |
| 4- 16 | 97- 37a | 2-126a | 1-199 |
| 2- 17 | 85- 37b | 1-142c | 1-212 |
| 1- 18a | 10- 38 | 1-155 | *1-M4 |
| 2- 19b | 2- 38d | 1-176 | |
| 1- 20a | 1- 40 | 1-186 | |

Not included in set No. 5

| |
|---------|
| 2- 5 |
| 2- 12c |
| 1- 15b |
| 2- 17 |
| 1- 18a |
| 1- 20a |
| 2- 22 |
| *1- 23a |
| 2- 24 |
| 3- 35 |
| 13- 37a |
| 9- 37b |
| 2- 48a |
| 1-111c |
| 2-126 |
| 1-186 |
| *1-186a |
| 1-186a |
| 1-212 |

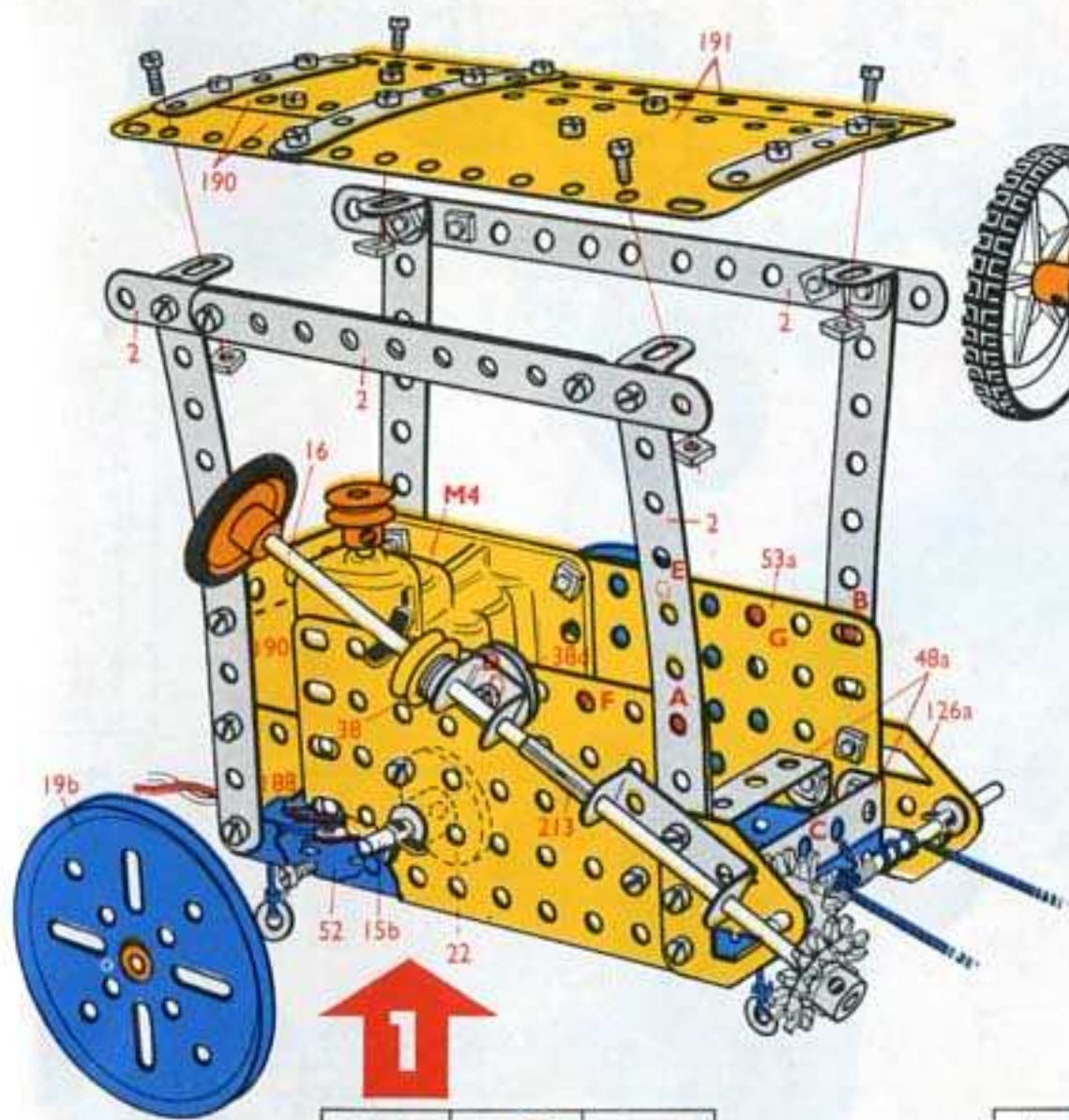

| | | |
|--------|---------|--------|
| 8- 2 | 1- 23a | 1- 52 |
| 1- 3 | 2- 27f | 2- 53a |
| 3- 5 | 4- 35 | 2-126a |
| 1- 11 | 52- 37a | 1-155 |
| 6- 12 | 52- 37b | 1-176 |
| 1- 15b | 10- 38 | 2-188 |
| 3- 16 | 2- 38d | 3-190 |
| 2- 19b | 1- 40 | 2-191 |
| 2- 22 | 1- 48 | |
| 1- 23 | 2- 48a | |

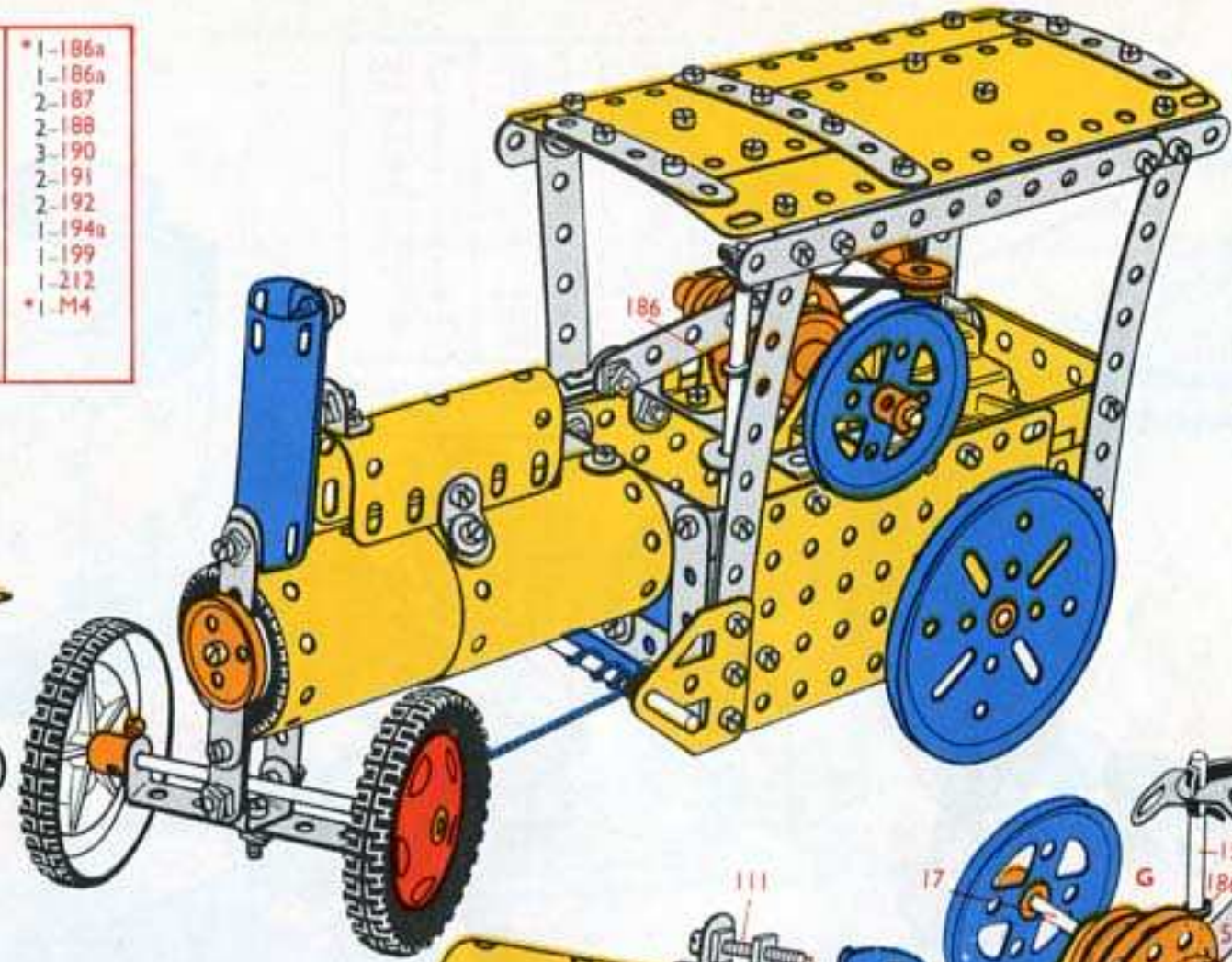

| | |
|---------|--------|
| 1- 3 | 1- 48 |
| 3- 5 | 1- 48a |
| 1- 11 | 1-111 |
| 1- 11a | 1-111c |
| 4- 12 | 2-125 |
| 2- 12c | 1-142c |
| 1- 16 | 2-187 |
| 2- 22a | 2-192 |
| 32- 37a | 1-194a |
| 24- 37b | 1-199 |

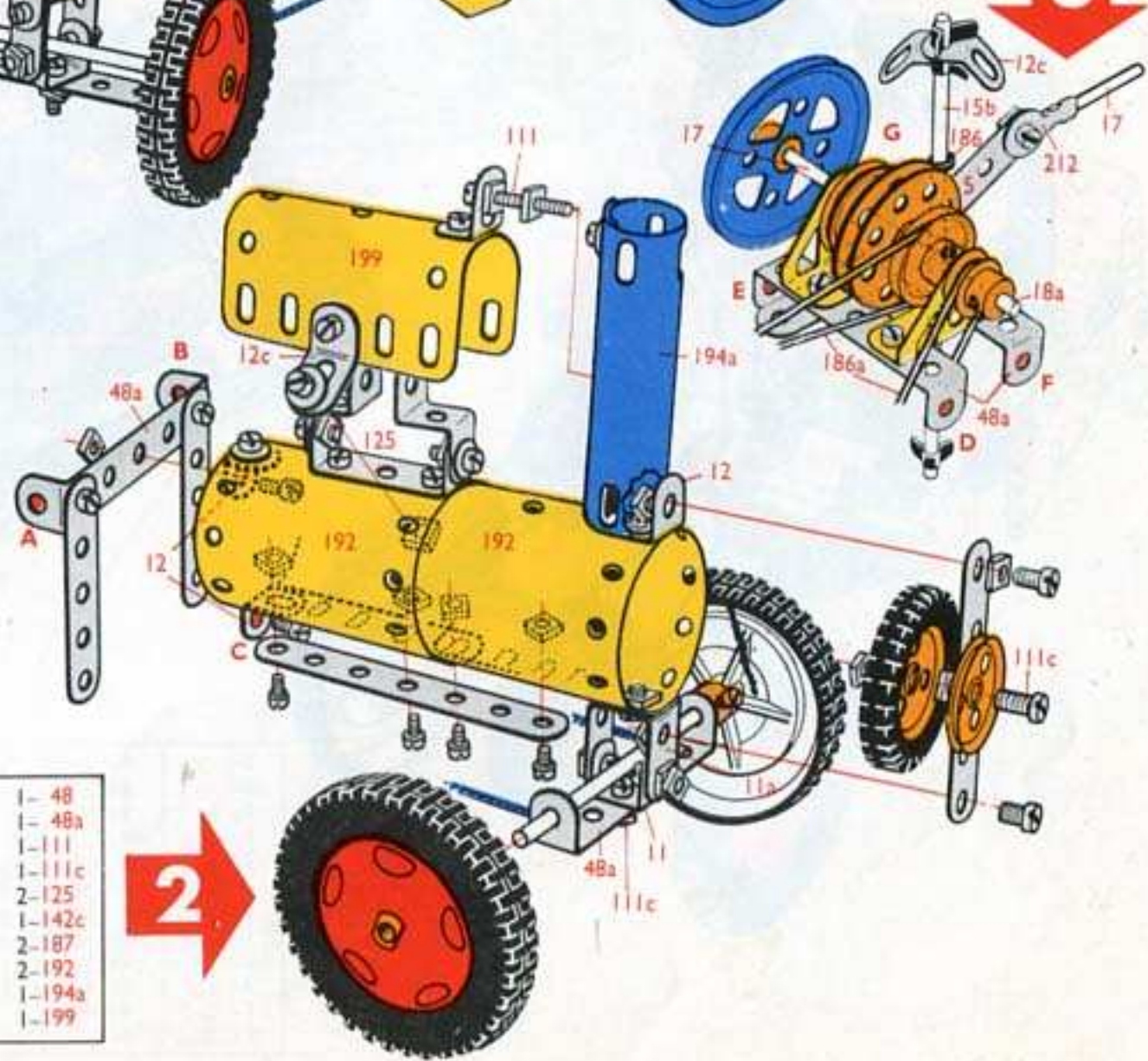

5.12

Dumper Truck
 Stortwagen
 Dumper
 Ribaltabile
 Kipplaster
 Tipptruck
 Camión volquete
 Carrinho basculante
 Dumperbil

| | | | |
|--------|---------|--------|---------|
| 2- 2 | 1- 20a | 6- 48a | *1-186b |
| 2- 3 | 4- 22 | 1- 51 | 2-187 |
| 9- 5 | 2- 22a | 2- 53a | 2-188 |
| 4- 10 | 1- 23 | 2- 54 | 2-189 |
| 2- 11 | *1- 23a | 4- 90a | 2-191 |
| 1- 11a | 1- 23a | 2-111 | 1-192 |
| 10-12 | 2- 24 | 5-111c | 1-212 |
| 2- 15b | 15- 35 | 2-125 | 2-212a |
| 4- 16 | 91- 37a | 2-126 | 2-214 |
| 1- 17 | 79- 37b | 2-126a | 2-221 |
| 1- 18a | 14- 38 | 2-142c | *1-M4 |
| 1- 18b | 2- 48 | 1-155 | |

*Not included in set No. 5

| | |
|--------|---------|
| 2- 3 | 25- 37a |
| 4- 5 | 17- 37b |
| 1- 10 | 2- 38 |
| 2- 11 | 1- 48 |
| 2- 12 | 2-111 |
| 1- 17 | 2-126 |
| 1- 18a | 2-142c |
| 1- 18b | 2-212a |
| 2- 22 | 1-214 |
| 2- 35 | |

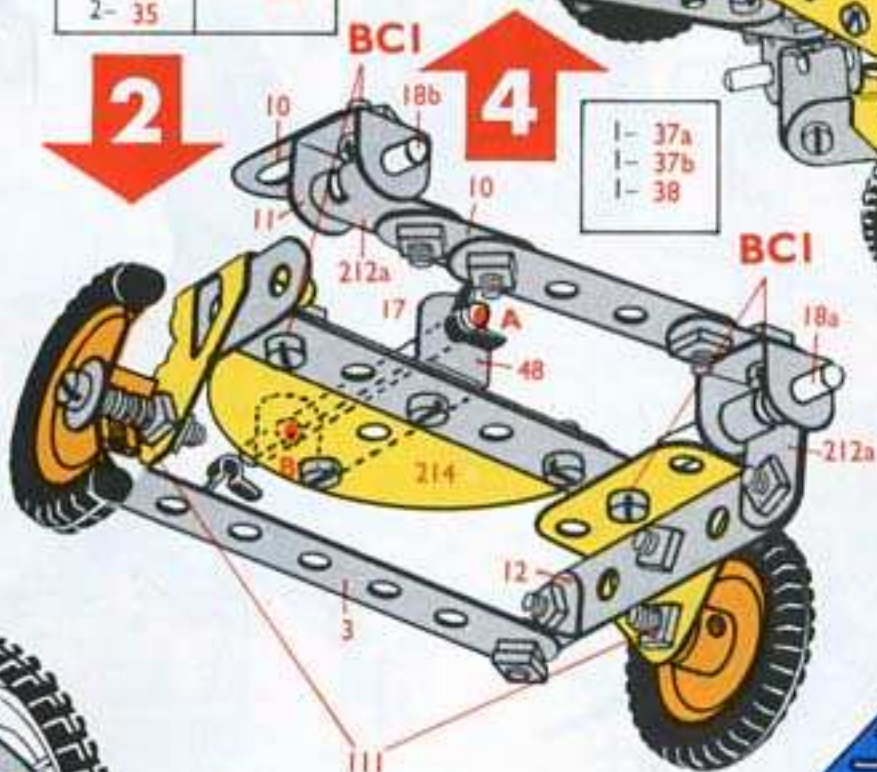
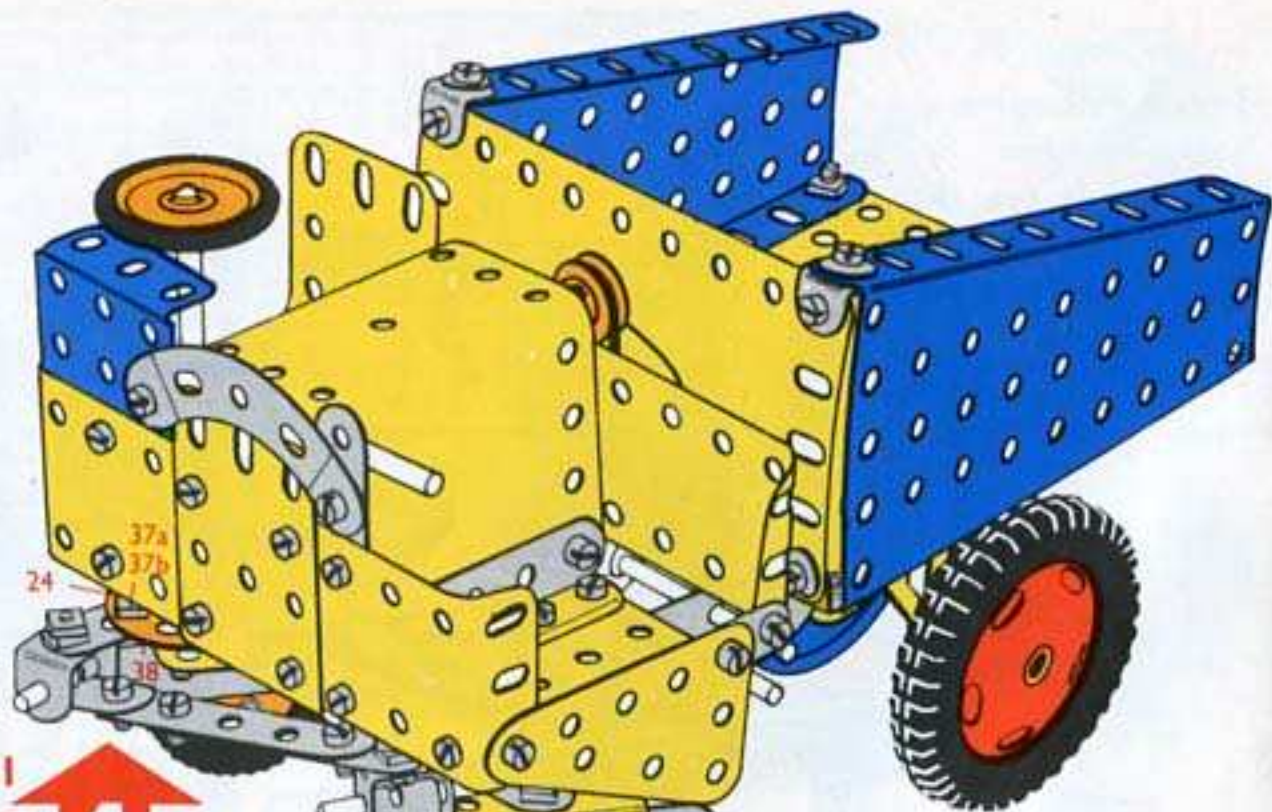

| |
|--------|
| 1- 37a |
| 1- 37b |
| 1- 38 |

| |
|---------|
| 2- 5 |
| 5- 12 |
| 1- 16 |
| 4- 35 |
| 17- 37a |
| 15- 37b |
| 6- 38 |
| 1- 48a |
| 1- 53a |
| 2- 54 |
| 2-111c |
| 2-191 |
| 1-214 |

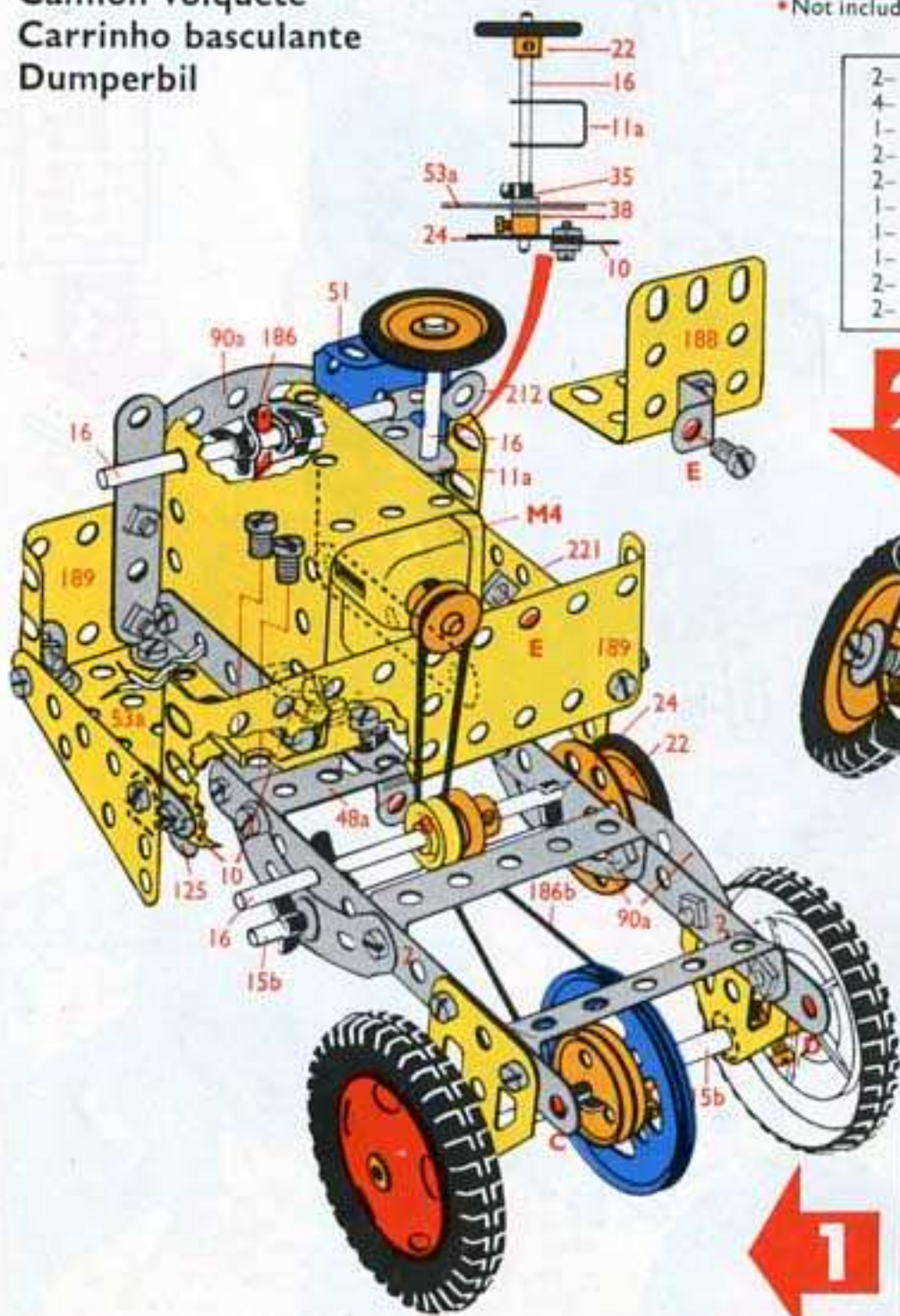

| | | |
|---------|---------|---------|
| 2- 2 | 1- 23a | 2- 125 |
| 3- 5 | 2- 24 | 2-126a |
| 3- 10 | 9- 35 | 1-155 |
| 1- 11a | 48- 37a | *1-186b |
| 3- 12 | 46- 37b | 2-187 |
| 2- 15b | 6- 38 | 2-188 |
| 3- 16 | 1- 48 | 2-189 |
| 1- 20a | 5- 48a | 1-192 |
| 2- 22 | 1- 51 | 1-212 |
| 2- 22a | 1- 53a | 2-221 |
| 1- 23 | 4- 90a | |
| *1- 23a | 3-111c | |

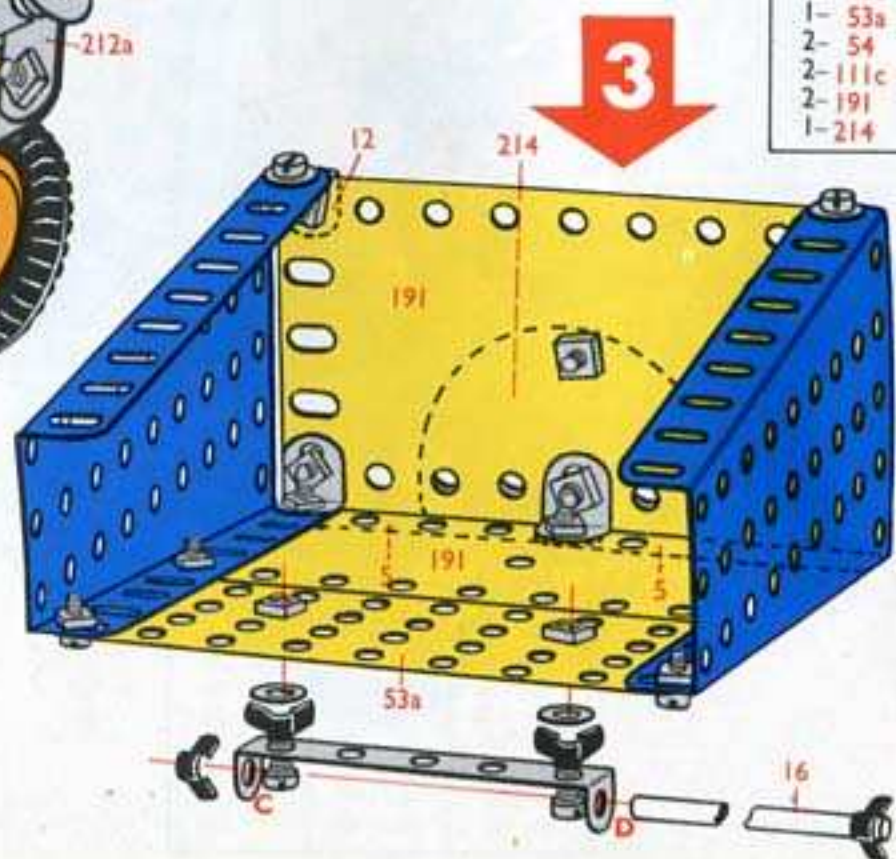

5.13

Food Mixer
Mixer voor voedingsmiddelen
Mixer pour aliments
Frullino
Speisemixer
Hushållsmaskin
Batidora
Misturadora para cozinha
Matblander

| | | | |
|--------|---------|---------|----------|
| 7- 2 | 4- 22 | 3- 48a | 2- 126a |
| 2- 3 | 1- 23 | 1- 51 | *1- 186b |
| 8- 5 | *1- 23a | 1- 52 | 2- 188 |
| 4- 10 | 1- 23a | 2- 53a | 2- 189 |
| 2- 11 | 2- 24 | 2- 54 | 1- 191 |
| 8- 12 | 2- 27f | 4- 90a | 2- 192 |
| 2- 15b | 2- 35 | 2- 111 | 1- 199 |
| 1- 17 | 87- 37a | 1- 111a | 1- 213 |
| 1- 18a | 80- 37b | 2- 111c | 2- 214 |
| 1- 18b | 13- 38 | 1- 125 | 3- 215 |
| 1- 20a | 2- 48 | 2- 126 | *1- M5 |

* Not included in set No. 5

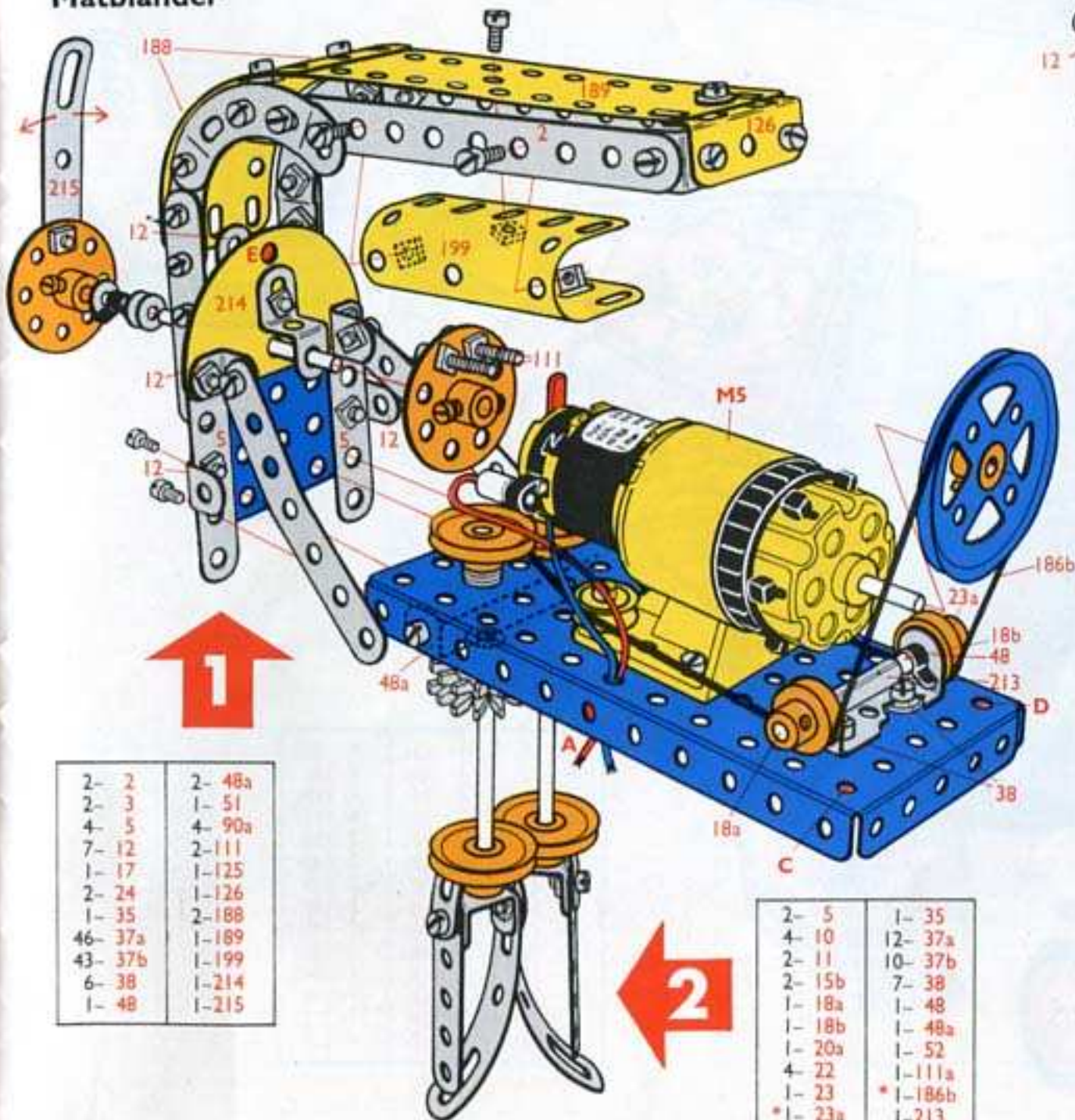

| | |
|---------|--------|
| 2- 2 | 2- 48a |
| 2- 3 | 1- 51 |
| 4- 5 | 4- 90a |
| 7- 12 | 2- 111 |
| 1- 17 | 1- 125 |
| 2- 24 | 1- 126 |
| 1- 35 | 2- 188 |
| 46- 37a | 1- 189 |
| 43- 37b | 1- 199 |
| 6- 38 | 1- 214 |
| 1- 48 | 1- 215 |

| | |
|---------|----------|
| 2- 5 | 1- 35 |
| 4- 10 | 12- 37a |
| 2- 11 | 10- 37b |
| 2- 15b | 7- 38 |
| 1- 18a | 1- 48 |
| 1- 18b | 1- 48a |
| 1- 20a | 1- 52 |
| 4- 22 | 1- 111a |
| 1- 23 | *1- 186b |
| *1- 23a | 1- 213 |
| 1- 23a | 1- 214 |
| 2- 27f | 2- 215 |

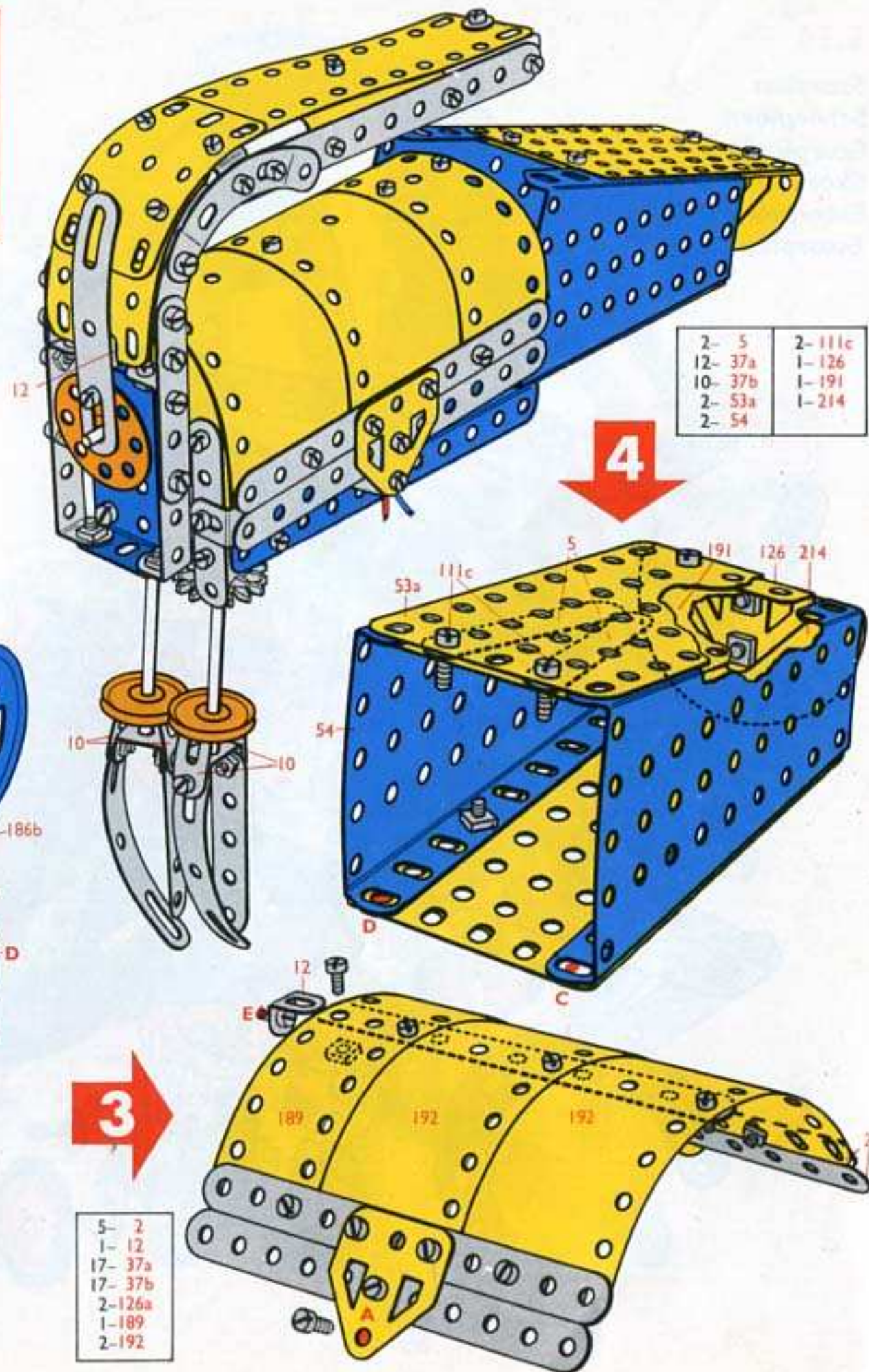

| | |
|---------|---------|
| 2- 5 | 2- 111c |
| 12- 37a | 1- 126 |
| 10- 37b | 1- 191 |
| 2- 53a | 1- 214 |
| 2- 54 | |

| |
|---------|
| 5- 2 |
| 1- 12 |
| 17- 37a |
| 17- 37b |
| 2- 126a |
| 1- 189 |
| 2- 192 |

5.14

Scorpion
 Schorpioen
 Scorpione
 Skorpion
 Escorpión
 Escorpião

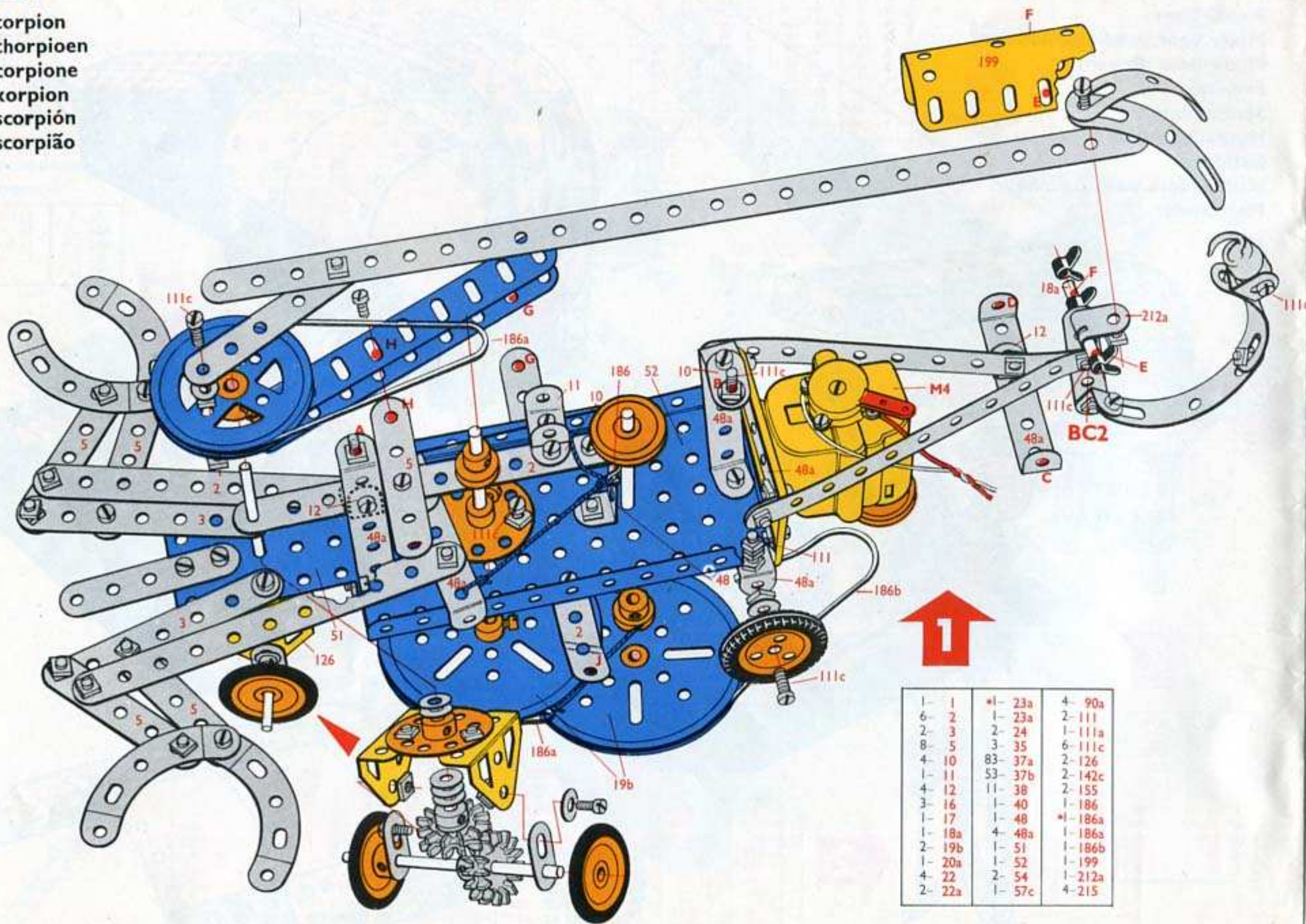

| | | |
|--------|---------|----------|
| 1- 1 | *1- 23a | 4- 90a |
| 6- 2 | 1- 23a | 2- 111 |
| 2- 3 | 2- 24 | 1- 111a |
| 8- 5 | 3- 35 | 6- 111c |
| 4- 10 | 83- 37a | 2- 126 |
| 1- 11 | 53- 37b | 2- 142c |
| 4- 12 | 11- 38 | 2- 155 |
| 3- 16 | 1- 40 | 1- 186 |
| 1- 17 | 1- 48 | *1- 186a |
| 1- 18a | 4- 48a | 1- 186a |
| 2- 19b | 1- 51 | 1- 186b |
| 1- 20a | 1- 52 | 1- 199 |
| 4- 22 | 2- 54 | 1- 212a |
| 2- 22a | 1- 57c | 4- 215 |

| | | | |
|--------|----------|----------|---------|
| 1- 1 | 2- 22a | 1- 57c | 2- 191 |
| 8- 2 | *1- 23a | 4- 90a | 2- 192 |
| 2- 3 | 1- 23a | 2- 111 | 1- 193 |
| 8- 5 | 2- 24 | 1- 111a | 2- 194 |
| 4- 10 | 3- 35 | 6- 111c | 1- 199 |
| 1- 11 | 107- 37a | 2- 126 | 1- 200 |
| 4- 12 | 75- 37b | 2- 142c | 1- 212a |
| 3- 12c | 13- 38 | 2- 155 | 2- 214 |
| 3- 16 | 1- 40 | 1- 186 | 4- 215 |
| 1- 17 | 1- 48 | *1- 186a | 4- 221 |
| 1- 18a | 4- 48a | 1- 186a | *1- M4 |
| 2- 19b | 1- 51 | 1- 186b | |
| 1- 20a | 1- 52 | 1- 189 | |
| 4- 22 | 2- 54 | 4- 190 | |

*Not included in set No. 5

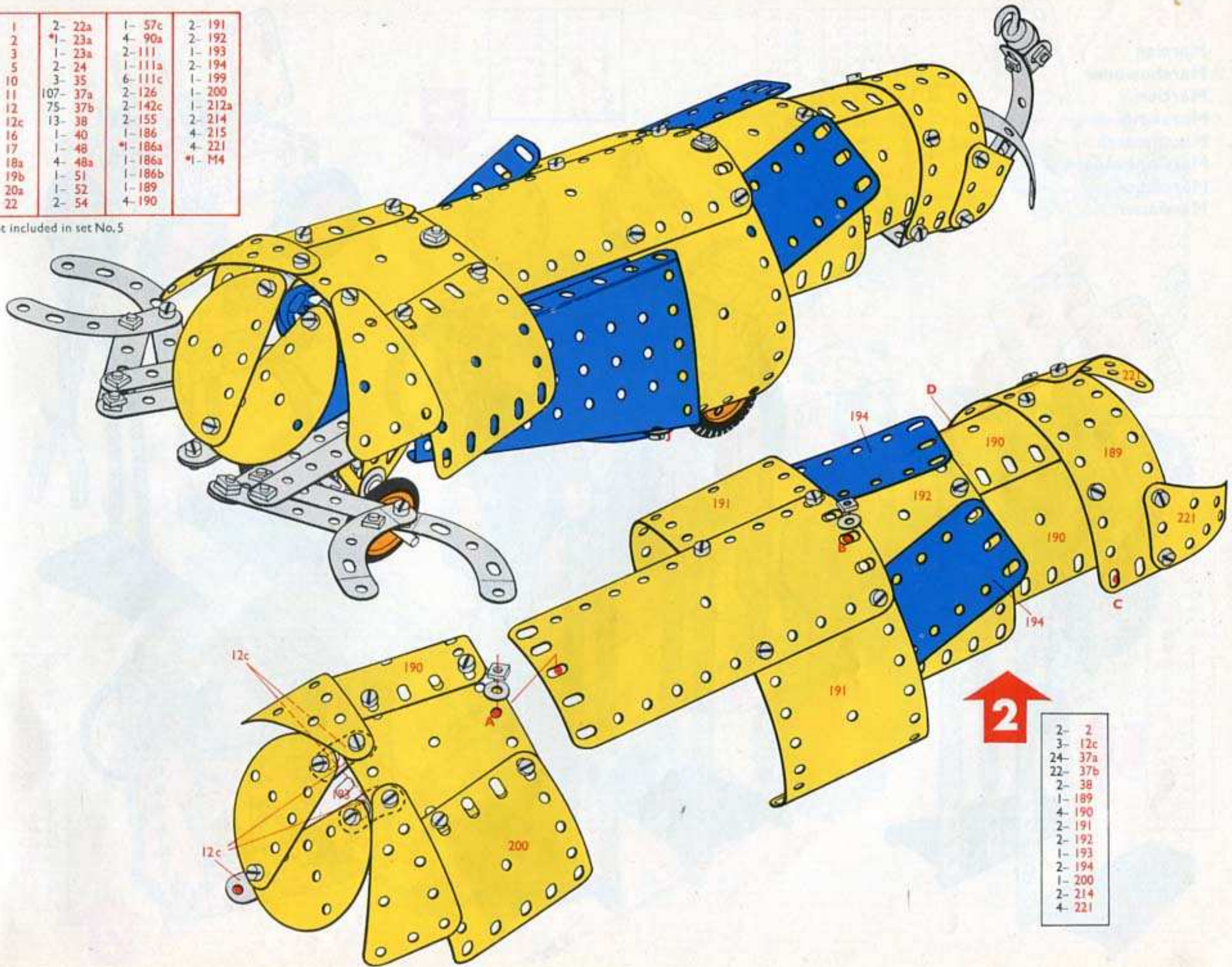

| |
|---------|
| 2- 2 |
| 3- 12c |
| 24- 37a |
| 22- 37b |
| 2- 38 |
| 1- 189 |
| 4- 190 |
| 2- 191 |
| 2- 192 |
| 1- 193 |
| 2- 194 |
| 1- 200 |
| 2- 214 |
| 4- 221 |

5.15

Martian
Marsbewoner
Martien
Marziano
Marsmensch
Marsinnevånare
Marciano
Marsianer

| | | | |
|--------|----------|--------|--------|
| 4- 1 | 1- 20a | 1- 51 | 2-189 |
| 8- 2 | 1- 22 | 1- 52 | 4-190 |
| 2- 3 | 1- 23a | 2- 53a | 2-191 |
| 9- 5 | 2- 24 | 2- 54 | 2-192 |
| 2- 10 | 2- 35 | 3- 90a | 2-194a |
| 2- 11 | 105- 37a | 2-111 | 1-200 |
| 1- 11a | 94- 37b | 1-111a | 1-212a |
| 10- 12 | 17- 38 | 4-111c | 2-214 |
| 2- 17 | 2- 38d | 2-126 | 4-215 |
| 1- 18a | 1- 40 | 2-126a | 4-221 |
| 1- 18b | 2- 48 | 2-187 | *1-M5 |
| 2- 19b | 6- 48a | 2-188 | |

| | |
|---------|--------|
| 4- 2 | 2- 38d |
| 1- 3 | 2-111c |
| 2- 12 | 1-192 |
| 2- 17 | 2-194a |
| 2- 19b | 2-214 |
| 2- 35 | 4-215 |
| 21- 37a | 4-221 |
| 19- 37b | |

* Not included in set No. 5

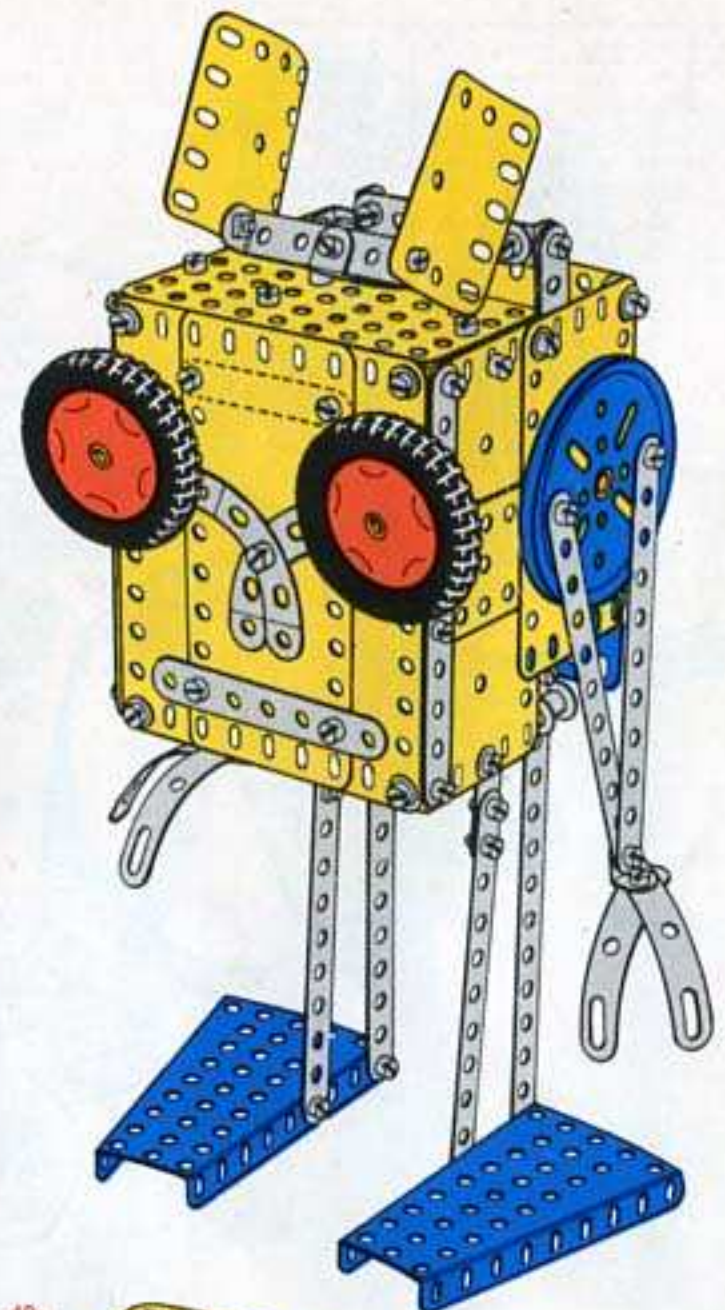
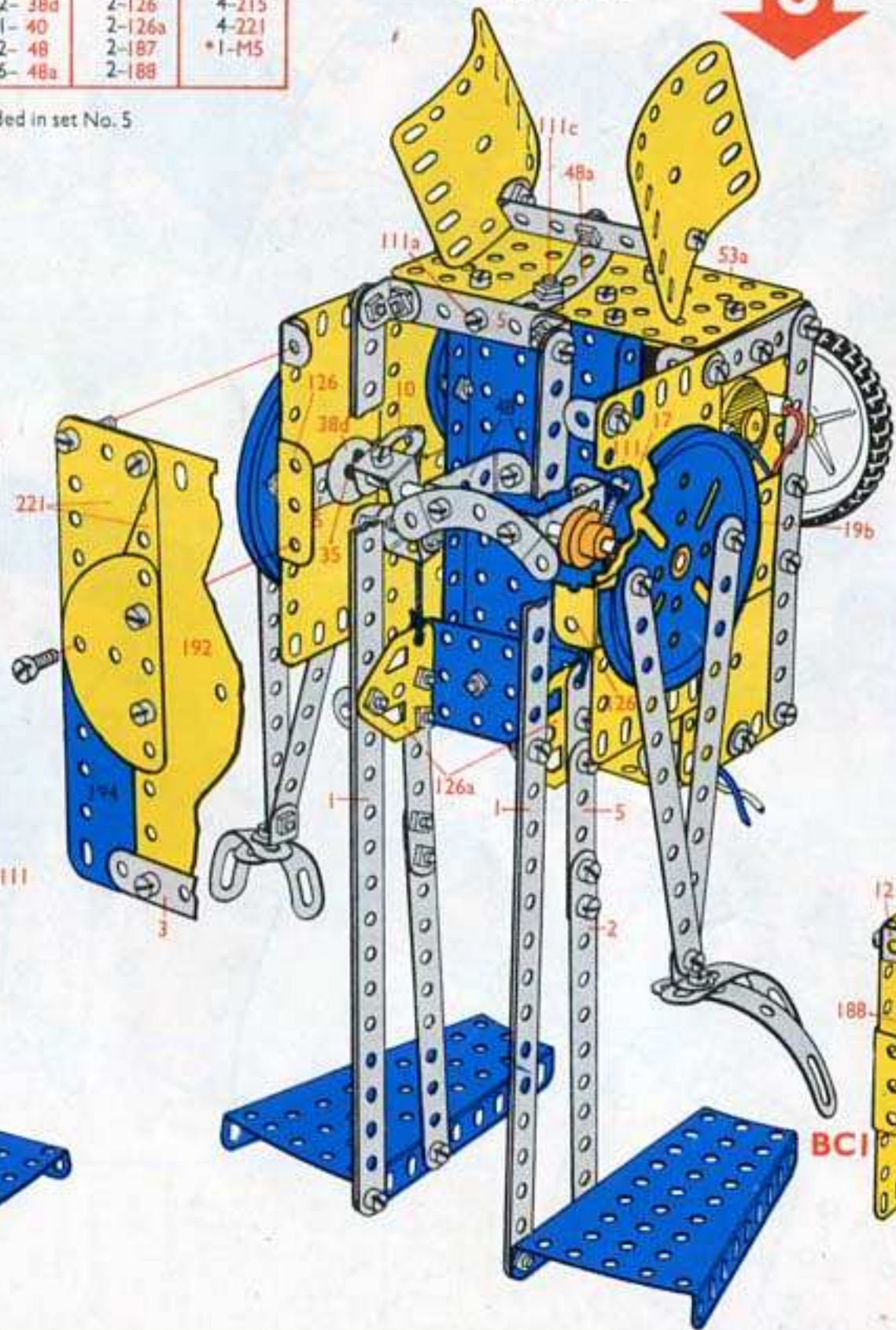
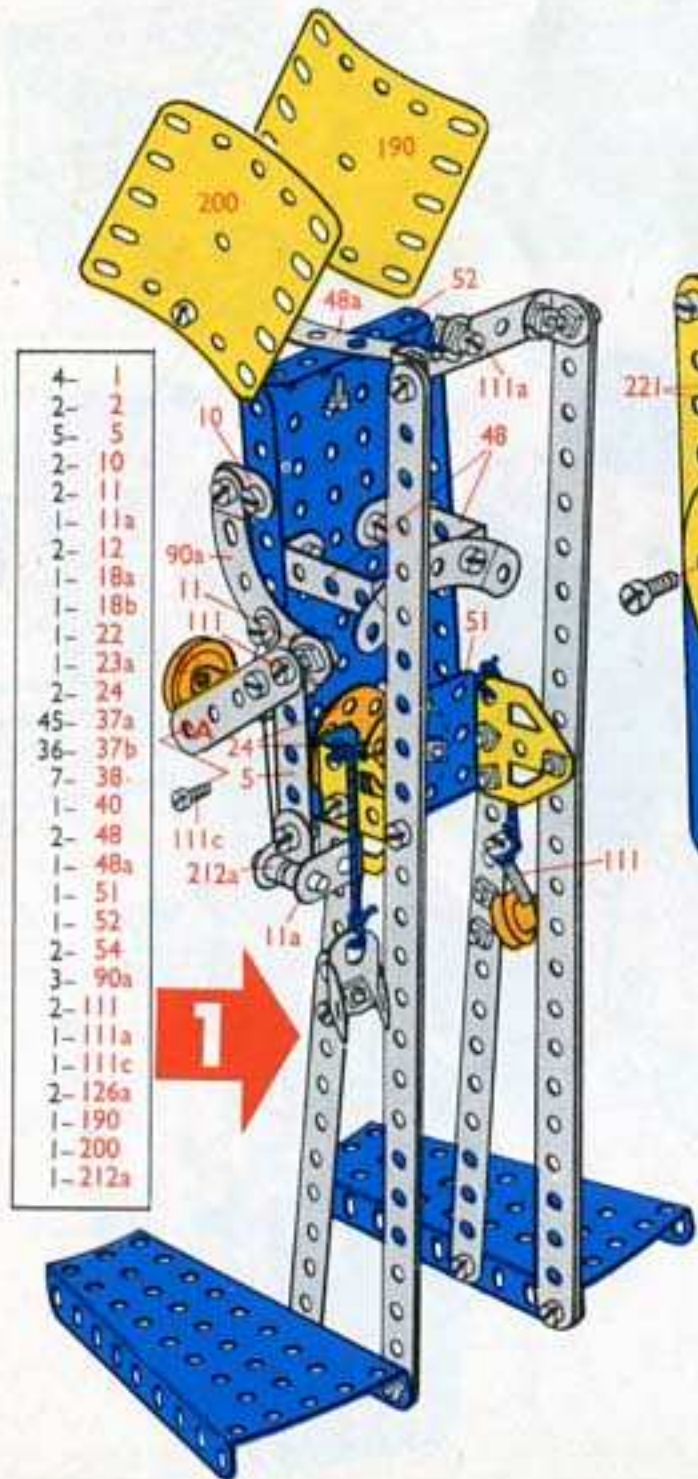

| |
|---------|
| 2- 2 |
| 1- 3 |
| 4- 5 |
| 6- 12 |
| 1- 20a |
| 39- 37a |
| 39- 37b |
| 10- 38 |
| 4- 48a |
| 2- 53a |
| 1-111c |
| 2-126 |
| 2-187 |
| 2-188 |
| 2-189 |
| 3-190 |
| 2-191 |
| 1-192 |

ELECTRONIC 5.16.

Automatic Press
 Automatische pers
 Presse automatique
 Pressa automatica
 Automatische Presse
 Automatisk press
 Prensa automatica
 Prensa Automatica
 Automatpresse

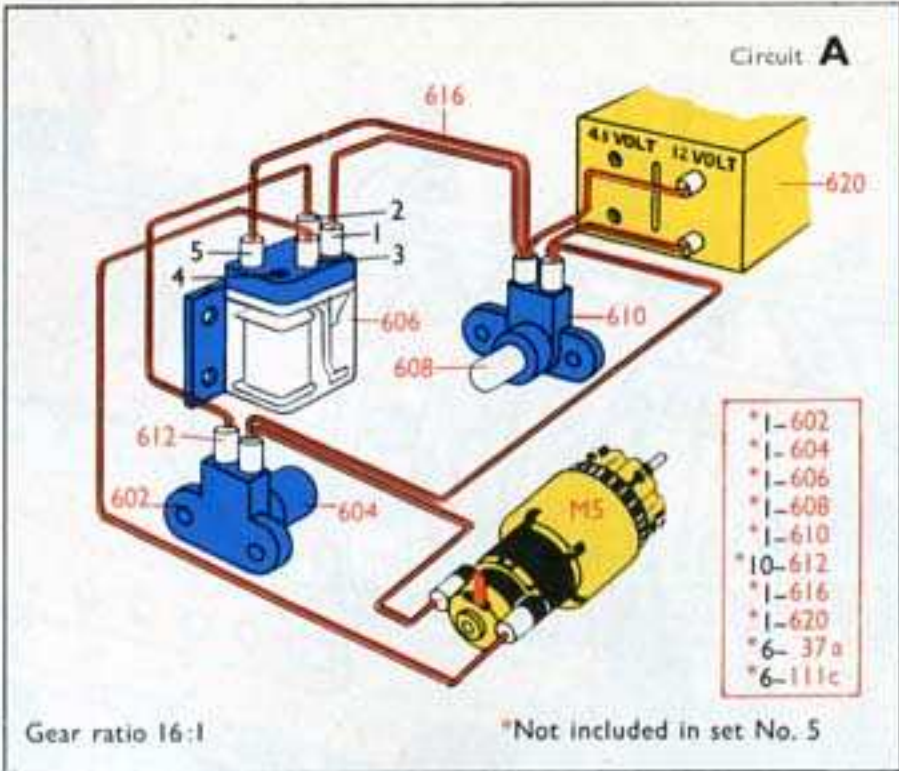

| | | |
|--------|--------|---------|
| 8- 2 | 1- 23a | 1-111a |
| 1- 3 | 2- 24 | 5-111c |
| 5- 5 | 2- 27f | 2-126 |
| 2-10 | 7- 35 | 2-126a |
| 2-15b | 52-37a | 1-186a |
| 1-16 | 44-37b | *1-186b |
| 2-17 | 16-38 | 1-191 |
| 2-18a | 2-48 | 1-212 |
| 1-18b | 6-48a | 1-213 |
| 1-19b | 1-51 | 2-214 |
| 1-20a | 1-52 | *1-M5 |
| 4-22 | 2-53a | |
| *1-23a | 2-54 | |

*Not included in set No. 5

| | |
|--------|--------|
| 2- 2 | 2- 35 |
| 1- 3 | 16-37a |
| 2- 5 | 14-37b |
| 2-15b | 8-38 |
| 1-20a | 1-52 |
| 2-22 | 2-54 |
| 1-23a | 2-111c |
| *1-23a | 2-126 |
| 2-27f | 1-186a |

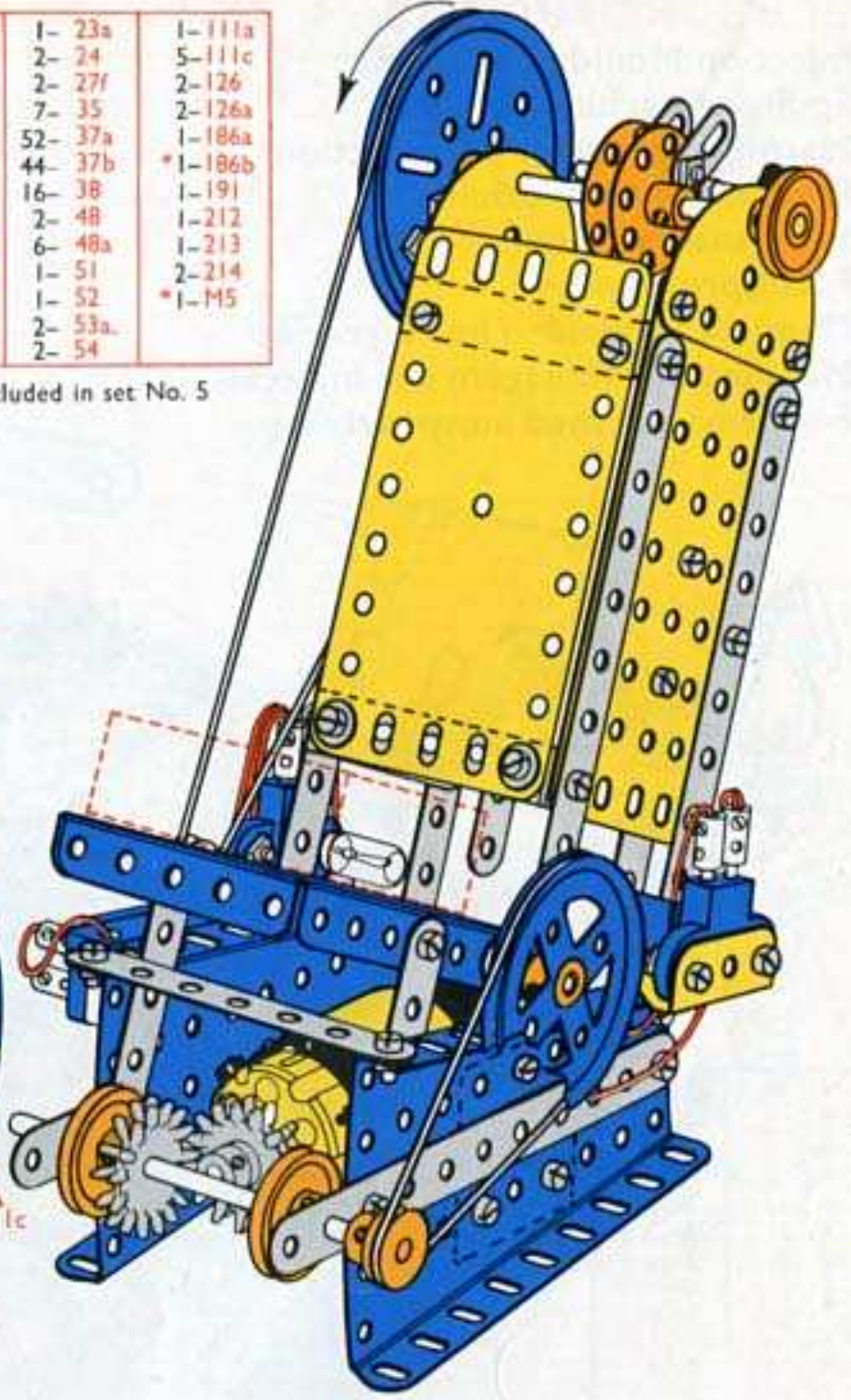
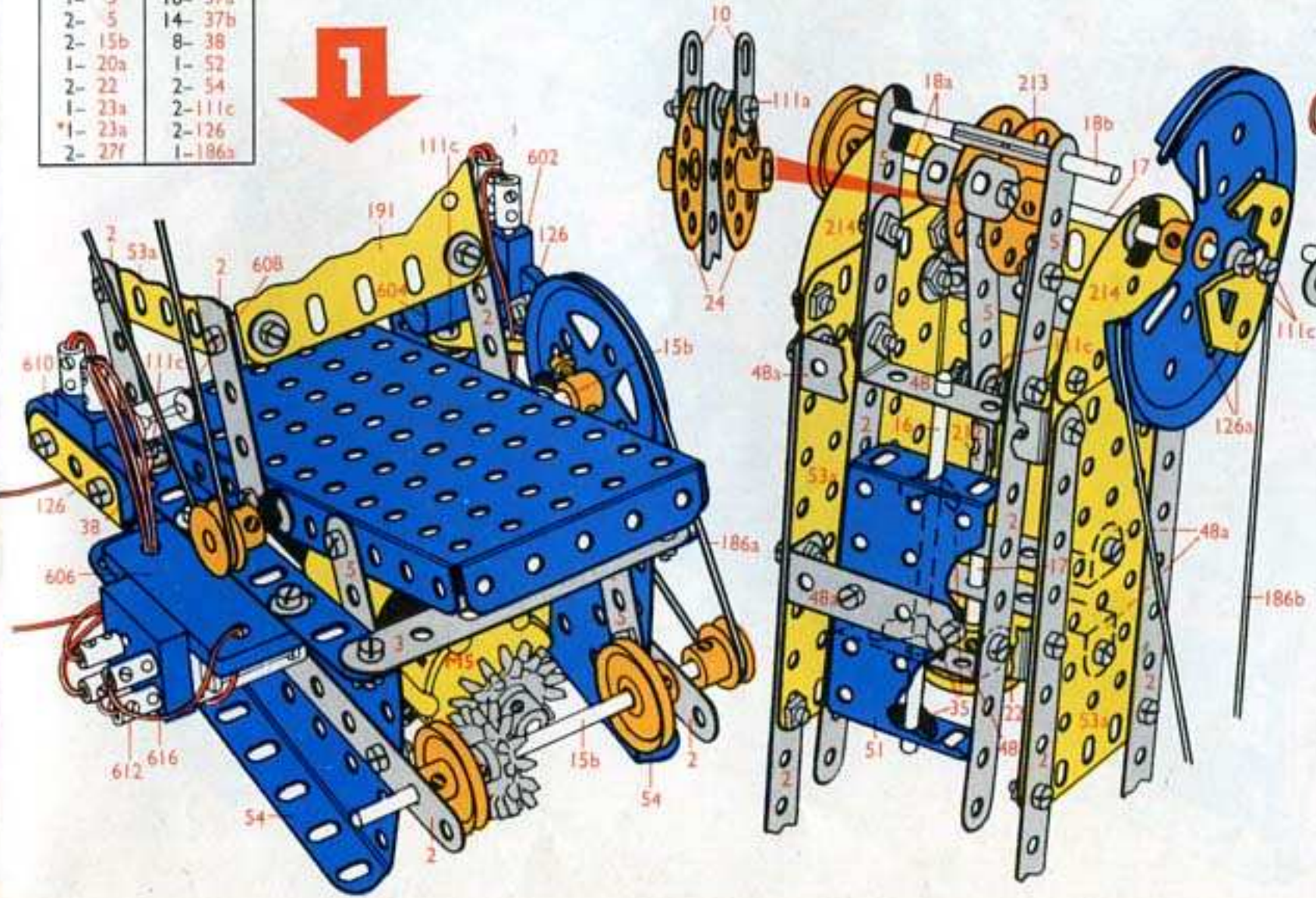

| | | |
|-------|--------|--------|
| 6- 2 | 2- 24 | 1-111a |
| 3- 5 | 5- 35 | 3-111c |
| 2-10 | 29-37a | 2-126a |
| 1-16 | 22-37b | 1-186b |
| 1-17 | 8-38 | 1-191 |
| 2-18a | 2-48 | 1-212 |
| 1-18b | 6-48a | 1-213 |
| 1-19b | 1-51 | 2-214 |
| 2-22 | 2-53a | |

ELECTRONIC 5.17.

Injection Moulding Machine

Spuitgietsmachine

Machine à moulage par injection

Formatrice ad iniezione

Spritgussmaschine

Formsprutmaskin

Máquina de moldeo por inyección

Máquina de Moldagem por Injecção

Formemaskin med innsprøytning

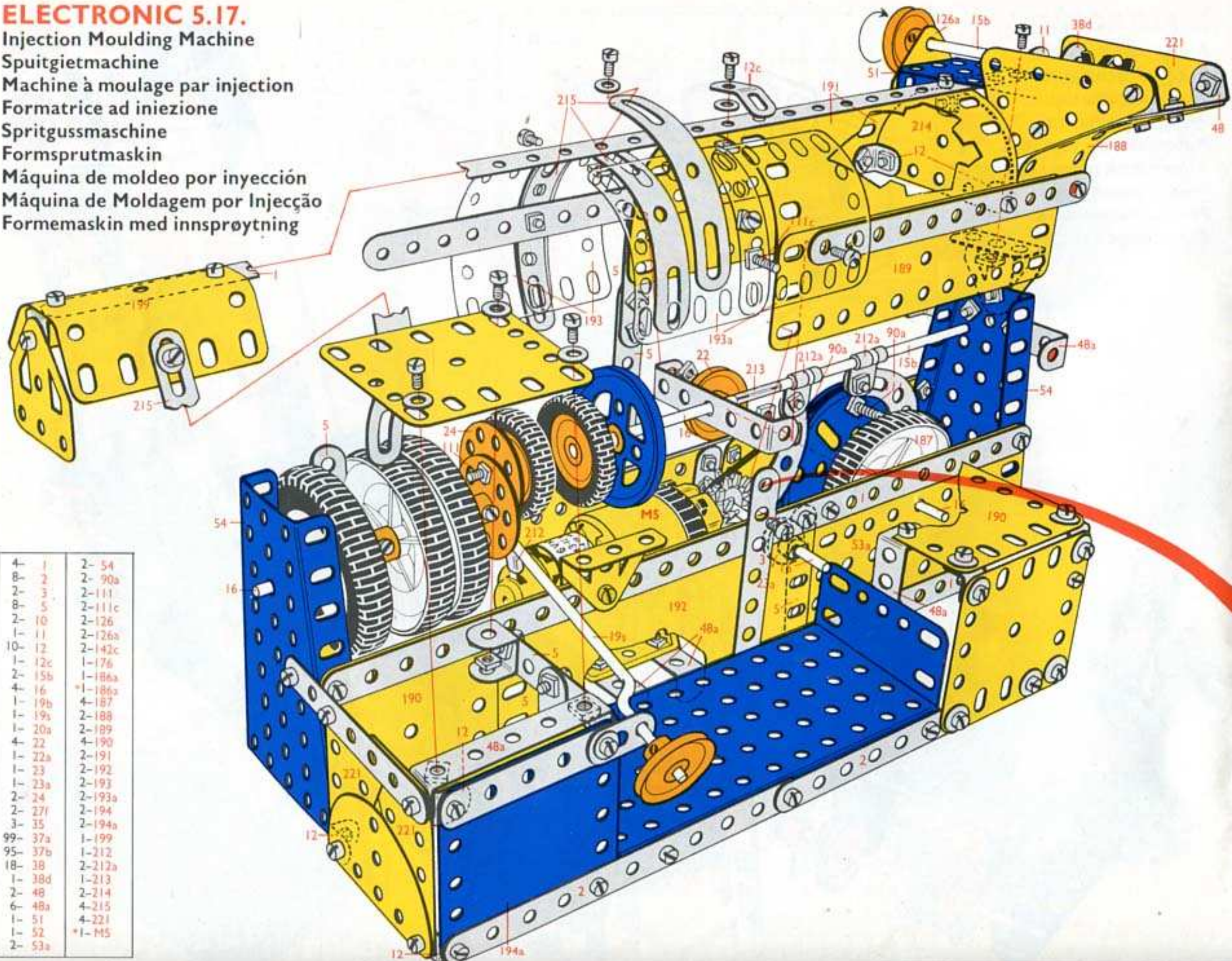

| | | | |
|-----|-----|-----|------|
| 4- | 1 | 2- | 54 |
| 8- | 2 | 2- | 90a |
| 2- | 3 | 2- | 111 |
| 8- | 5 | 2- | 111c |
| 2- | 10 | 2- | 126 |
| 1- | 11 | 2- | 126a |
| 10- | 12 | 2- | 142c |
| 1- | 12c | 1- | 176 |
| 2- | 15b | 1- | 186a |
| 4- | 16 | *1- | 186a |
| 1- | 19b | 4- | 187 |
| 1- | 19a | 2- | 188 |
| 1- | 20a | 2- | 189 |
| 4- | 22 | 4- | 190 |
| 1- | 22a | 2- | 191 |
| 1- | 23 | 2- | 192 |
| 1- | 23a | 2- | 193 |
| 2- | 24 | 2- | 193a |
| 2- | 27f | 2- | 194 |
| 3- | 35 | 2- | 194a |
| 99- | 37a | 1- | 199 |
| 95- | 37b | 1- | 212 |
| 18- | 38 | 2- | 212a |
| 1- | 38d | 1- | 213 |
| 2- | 48 | 2- | 214 |
| 6- | 48a | 4- | 215 |
| 1- | 51 | 4- | 221 |
| 1- | 52 | *1- | M5 |
| 2- | 53a | | |

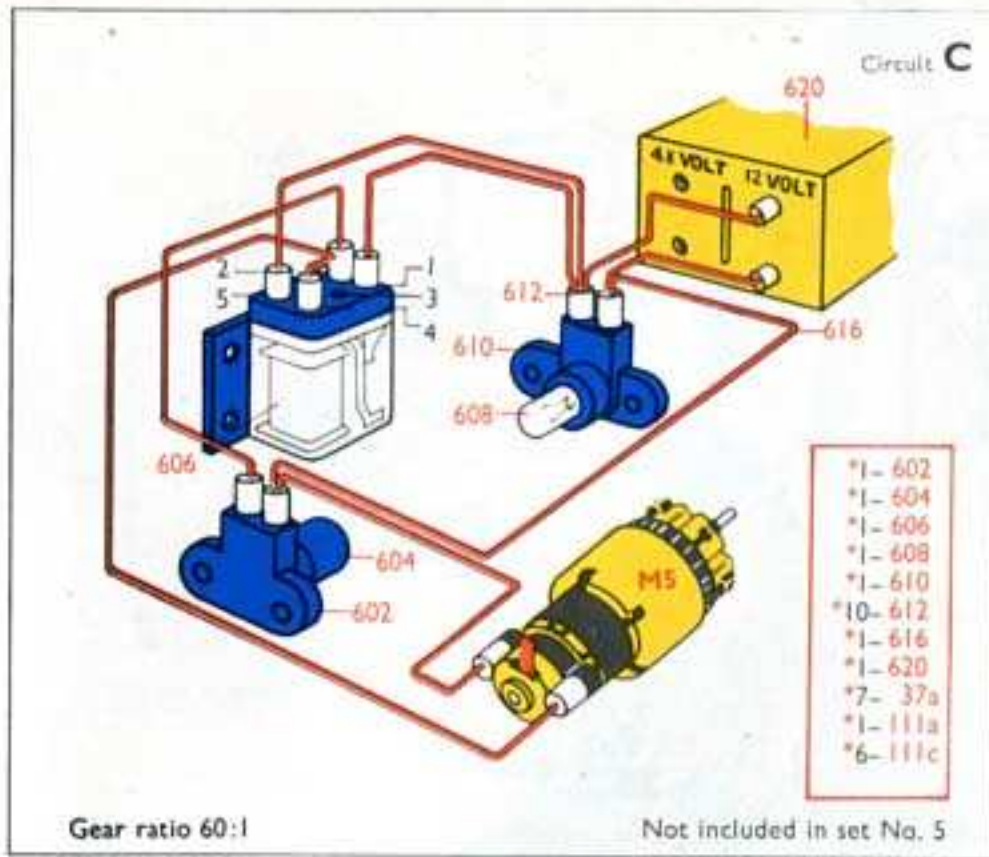

| | | | |
|--------|---------|----------|---------|
| 4- 1 | 1- 23 | 2- 90a | 2- 193 |
| 8- 2 | 1- 23a | 2- 111 | 2- 193a |
| 2- 3 | 2- 24 | 2- 111c | 2- 194 |
| 8- 5 | 2- 27f | 2- 126 | 2- 194a |
| 2- 10 | 3- 35 | 2- 126a | 1- 199 |
| 1- 11 | 99- 37a | 2- 142c | 1- 212 |
| 10- 12 | 95- 37b | 1- 176 | 2- 212a |
| 1- 12c | 18- 38 | 1- 186a | 1- 213 |
| 2- 15b | 1- 38d | *1- 186a | 2- 214 |
| 4- 16 | 2- 48 | 4- 187 | 4- 215 |
| 1- 19b | 6- 48a | 2- 188 | 4- 221 |
| 1- 19s | 1- 51 | 2- 189 | *1- 245 |
| 1- 20a | 1- 52 | 4- 190 | |
| 4- 22 | 2- 53a | 2- 191 | |
| 1- 22a | 2- 54 | 2- 192 | |

*Not included in set No. 5

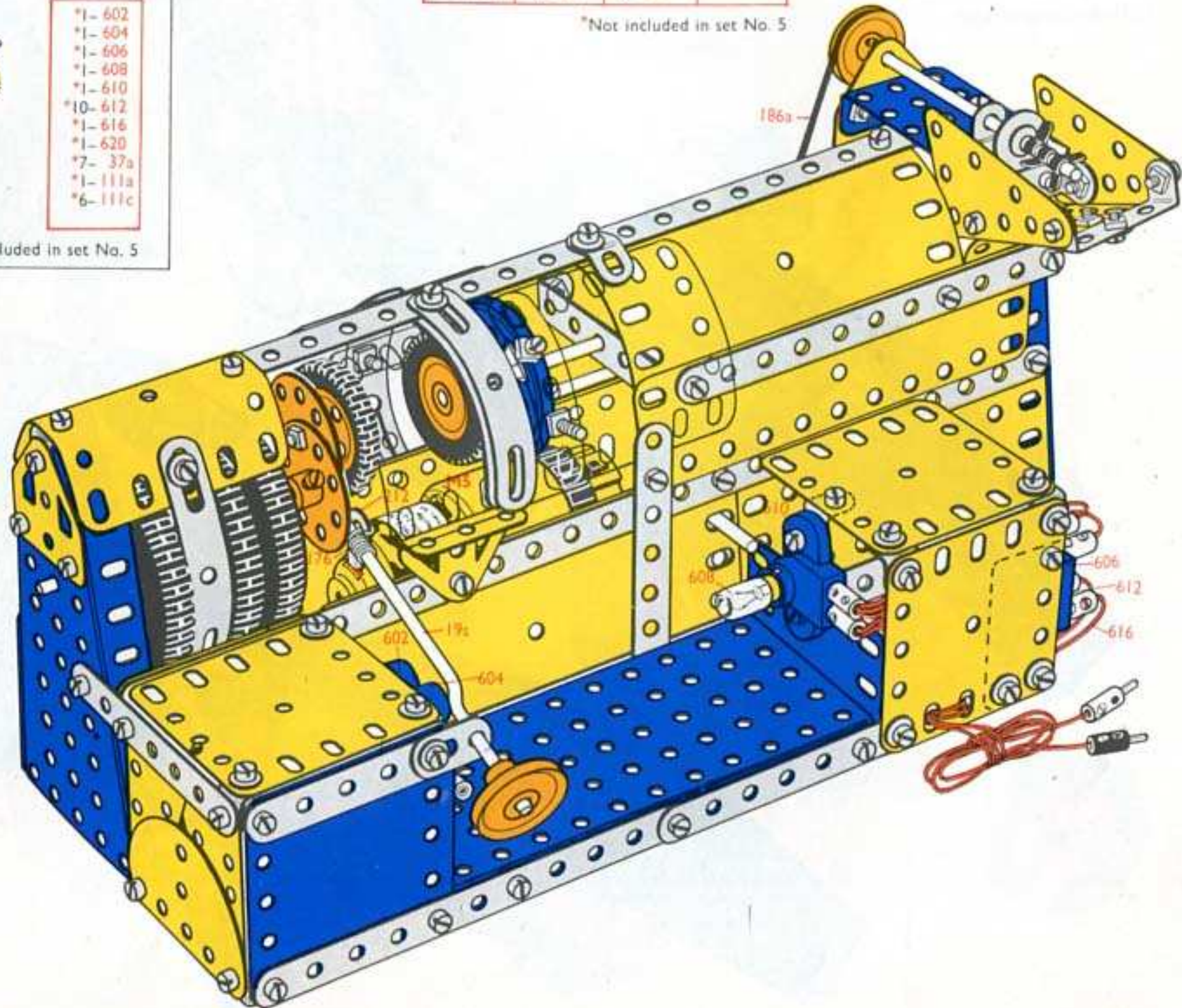
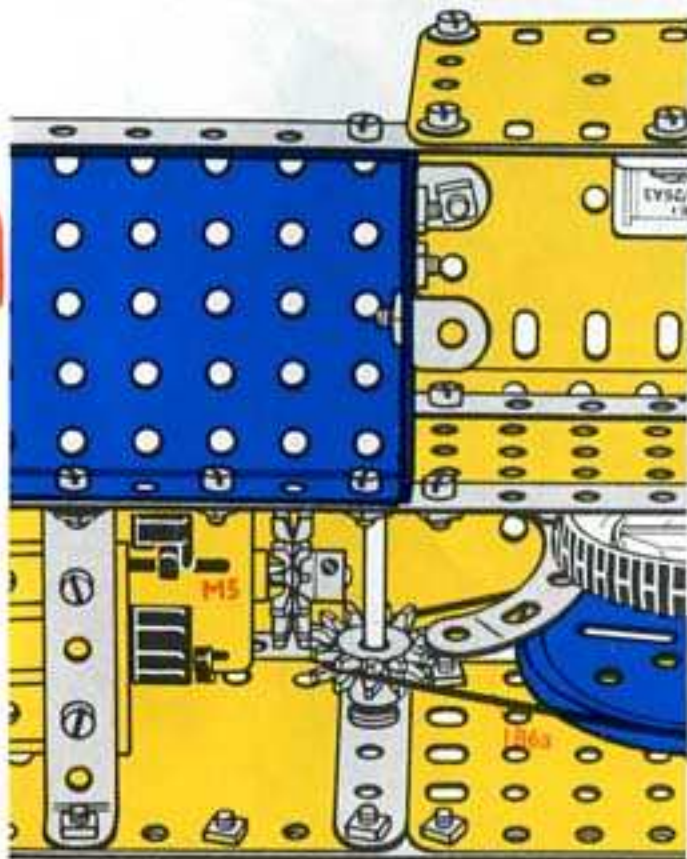

ELECTRONIC 5.18.

- Counting Conveyor
- Teltransporteur
- Convoyeur-compteur
- Trasportatore contatore
- Zahlforderer
- Transportor med rakneverk
- Transportador contador
- Transportador Contador
- Telletransportor

| | | | |
|----|-----|--------|---------|
| 4 | 1 | 1-23a | 2-111a |
| 5 | 2 | 2-24 | 2-111c |
| 2 | 3 | 2-27f | 2-126 |
| 9 | 5 | 14-35 | 2-126a |
| 4 | 10 | 87-37a | 1-155 |
| 2 | 11 | 71-37b | 1-186 |
| 1 | 11a | 18-38 | 1-186a |
| 8 | 12 | 2-38d | *1-186a |
| 2 | 15b | 1-40 | 2-190 |
| 4 | 16 | 1-48 | 2-192 |
| 1 | 17 | 6-48a | 1-212 |
| 2 | 19b | 1-51 | 2-212a |
| 1 | 20a | 1-52 | 1-213 |
| 4 | 22 | 2-53a | 2-214 |
| 2 | 22a | 2-54 | *1-M5 |
| 1 | 23 | 4-90a | |
| *1 | 23a | 1-111 | |

*Not included in set No. 5

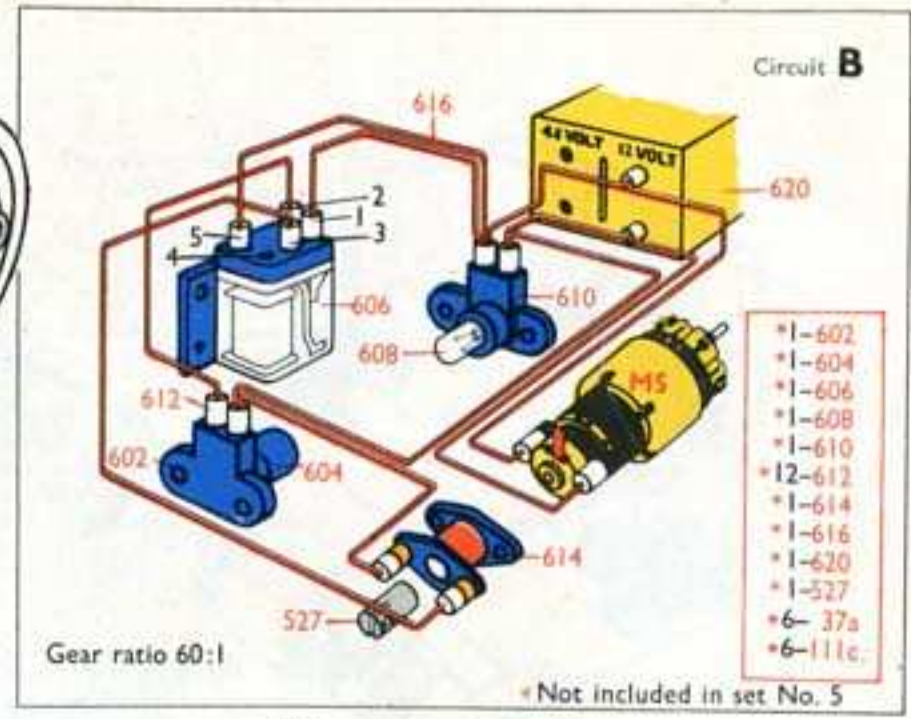

- *1-602
- *1-604
- *1-606
- *1-608
- *1-610
- *12-612
- *1-614
- *1-616
- *1-620
- *1-527
- *6-37a
- *6-111c

*Not included in set No. 5

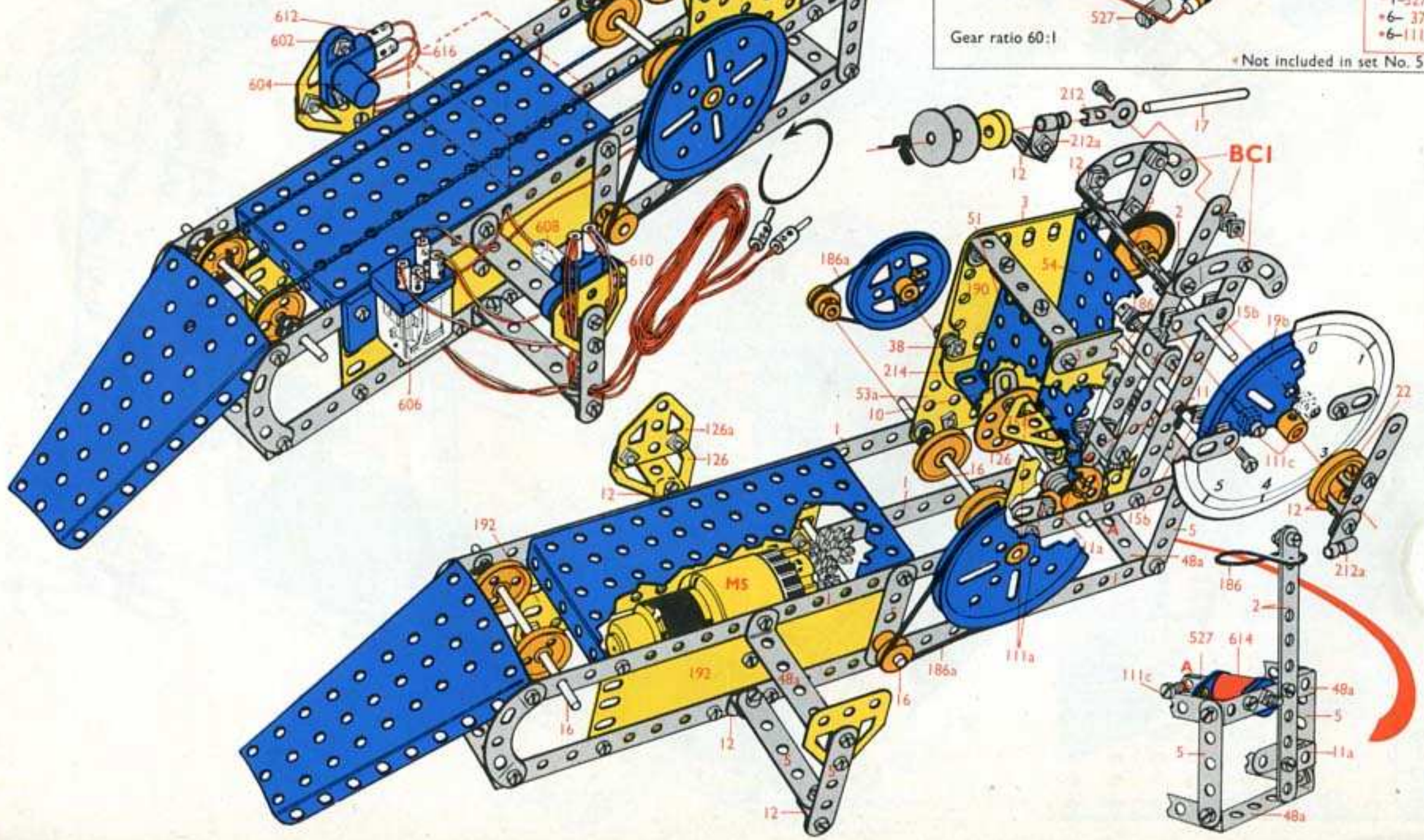

6.1.
Breakdown Truck
Takelwagen
Camion de dépannage
Carro attrezzi
Abschleppwagen
Bärgningsbil
Camión-grúa
Camião de Reboque
Service-vogn

| | | | | | | | |
|----|-----|-----|-----|---|------|---|------|
| 14 | 2 | 2 | 22a | 1 | 52 | 1 | 176 |
| 2 | 3 | 1 | 23a | 2 | 53a | 4 | 187 |
| 12 | 5 | 2 | 24 | 2 | 54 | 4 | 188 |
| 2 | 6a | 1 | 26 | 1 | 57c | 2 | 189 |
| 4 | 11 | 1 | 27a | 1 | 80c | 3 | 190 |
| 1 | 11a | 9 | 35 | 4 | 90a | 2 | 191 |
| 12 | 12 | 144 | 37a | 2 | 111a | 3 | 192 |
| 2 | 12a | 128 | 37b | 4 | 111c | 2 | 212a |
| 2 | 15 | 21 | 38 | 1 | 115 | 2 | 214 |
| 1 | 15a | 2 | 38d | 4 | 125 | 4 | 215 |
| 2 | 17 | 1 | 40 | 2 | 126 | 4 | 221 |
| 3 | 18a | 2 | 48 | 1 | 126a | | |
| 1 | 18b | 8 | 48a | 1 | 147b | | |
| 2 | 22 | 1 | 51 | 1 | 155 | | |

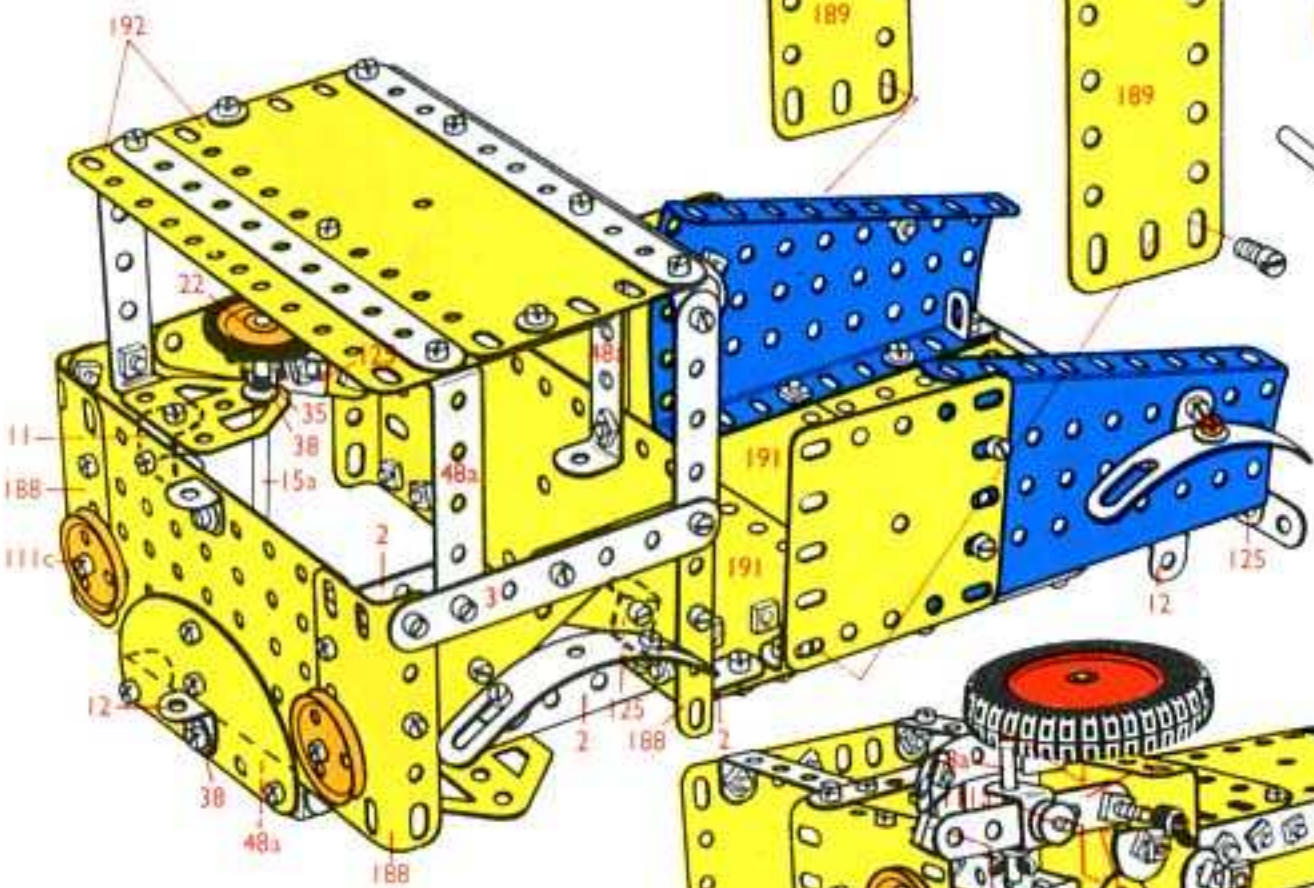
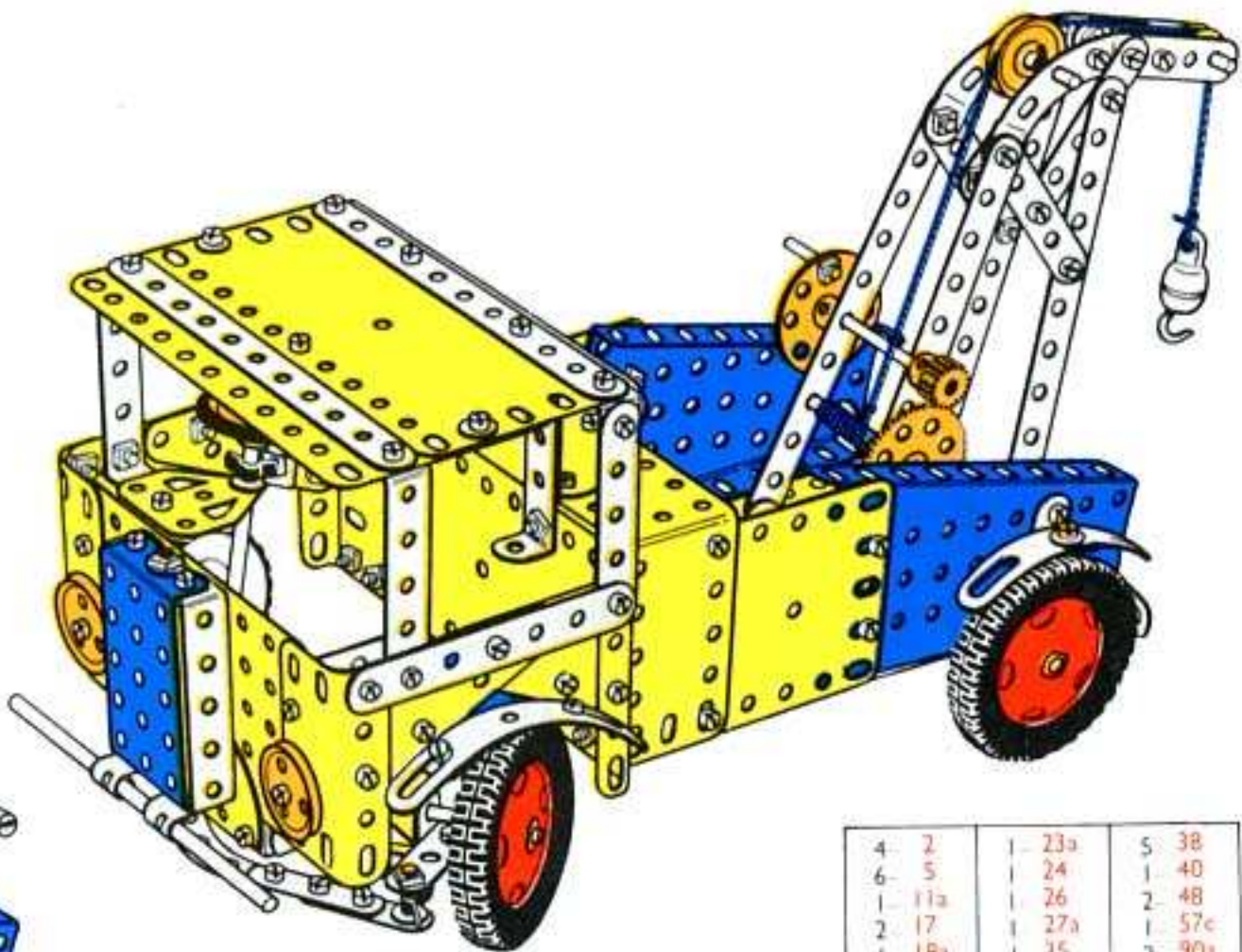

| | | | | | |
|---|-----|----|-----|---|-----|
| 4 | 2 | 1 | 23a | 5 | 38 |
| 6 | 5 | 1 | 24 | 1 | 40 |
| 1 | 11a | 1 | 26 | 2 | 48 |
| 2 | 17 | 1 | 27a | 1 | 57c |
| 1 | 18a | 1 | 35 | 2 | 90a |
| 1 | 18b | 22 | 37a | 1 | 115 |
| 1 | 22 | 22 | 37b | 1 | 176 |

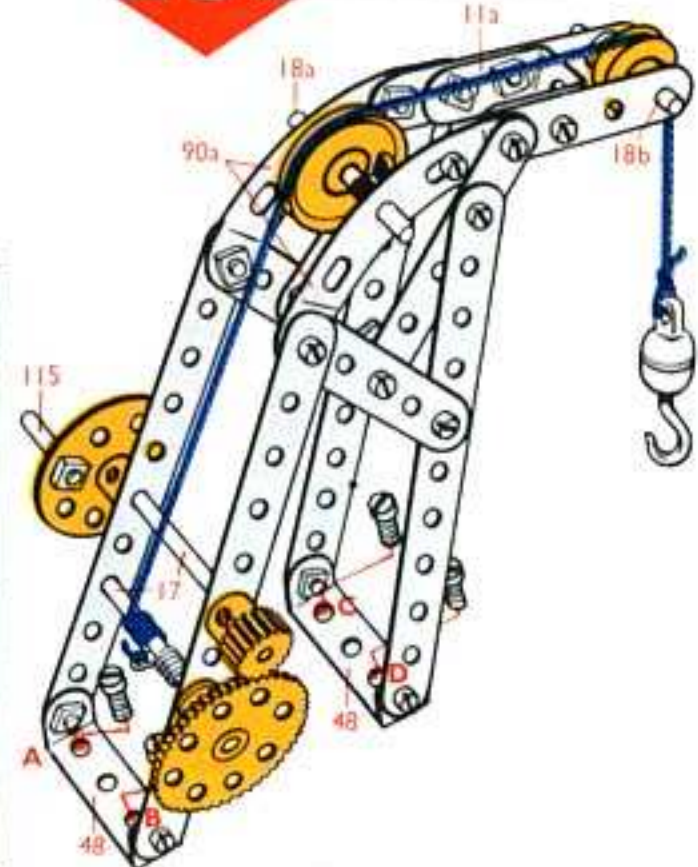

| | |
|----|------|
| 4 | 5 |
| 2 | 6a |
| 3 | 11 |
| 2 | 15 |
| 3 | 18a |
| 1 | 24 |
| 7 | 35 |
| 26 | 37a |
| 12 | 37b |
| 7 | 38 |
| 2 | 38d |
| 2 | 48a |
| 1 | 51 |
| 1 | 80c |
| 2 | 90a |
| 2 | 111a |
| 2 | 111c |
| 2 | 126 |
| 1 | 147b |
| 4 | 187 |
| 2 | 212a |

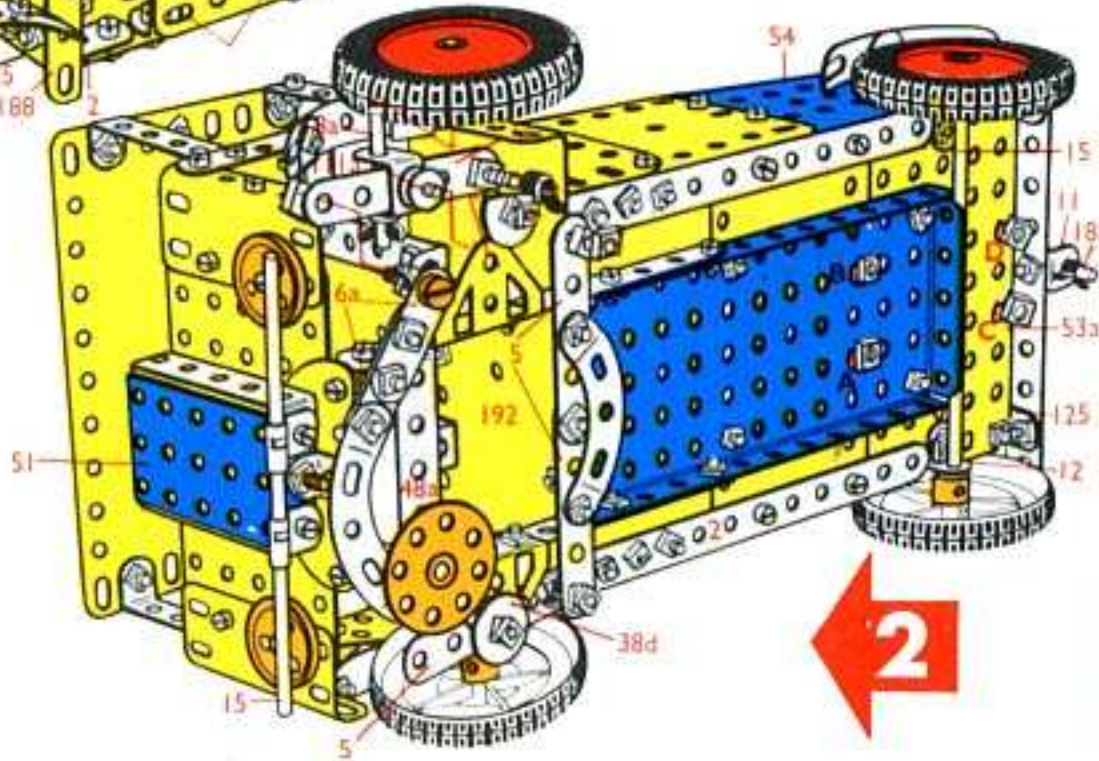

| | | | |
|----|-----|---|------|
| 10 | 2 | 2 | 53a |
| 2 | 3 | 2 | 54 |
| 2 | 5 | 2 | 111c |
| 1 | 11 | 4 | 125 |
| 12 | 12 | 1 | 126a |
| 2 | 12a | 1 | 155 |
| 1 | 15a | 4 | 188 |
| 1 | 22 | 2 | 189 |
| 2 | 22a | 3 | 190 |
| 1 | 35 | 2 | 191 |
| 96 | 37a | 3 | 192 |
| 94 | 37b | 2 | 214 |
| 9 | 38 | 4 | 215 |
| 6 | 48a | 4 | 221 |
| 1 | 52 | | |

6.2.

Cargo Crane
 Vrachtkraan
 Grue de cargo
 Gru portuale
 Lastkran
 Lastkran
 Grúa de carga
 Guindaste de Carga
 Lastekran

| | | | |
|----|-----|---|------|
| 4 | 2 | 1 | 40 |
| 3 | 5 | 1 | 48 |
| 2 | 16 | 4 | 48a |
| 2 | 17 | 1 | 52 |
| 1 | 19b | 2 | 53a |
| 1 | 19a | 1 | 111c |
| 1 | 20a | 1 | 176 |
| 2 | 22a | 2 | 188 |
| 1 | 26 | 2 | 190 |
| 1 | 27a | 2 | 191 |
| 3 | 35 | 1 | 192 |
| 44 | 37a | 2 | 193 |
| 38 | 37b | 1 | 193a |
| 7 | 38 | 1 | 213 |
| 2 | 38d | 2 | 214 |

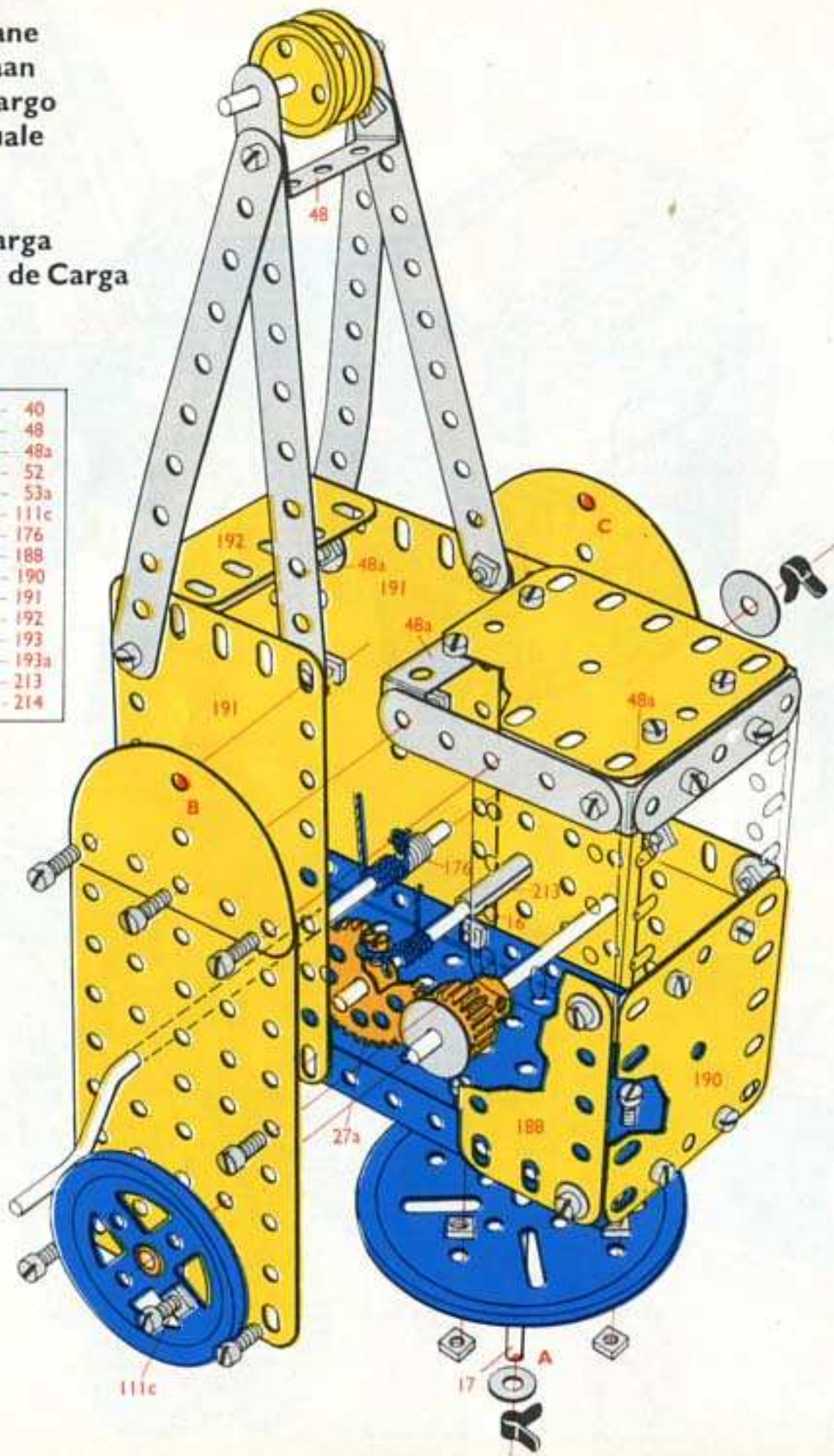

| | | | |
|----|-----|----|------|
| 4 | 1 | 54 | 37b |
| 10 | 2 | 12 | 38 |
| 2 | 5 | 2 | 48a |
| 4 | 8 | 1 | 51 |
| 4 | 11 | 2 | 90a |
| 1 | 16 | 2 | 111 |
| 4 | 18a | 2 | 111a |
| 1 | 19b | 1 | 155 |
| 5 | 22 | 2 | 188 |
| 2 | 27f | 4 | 189 |
| 10 | 35 | 4 | 221 |
| 62 | 37a | | |

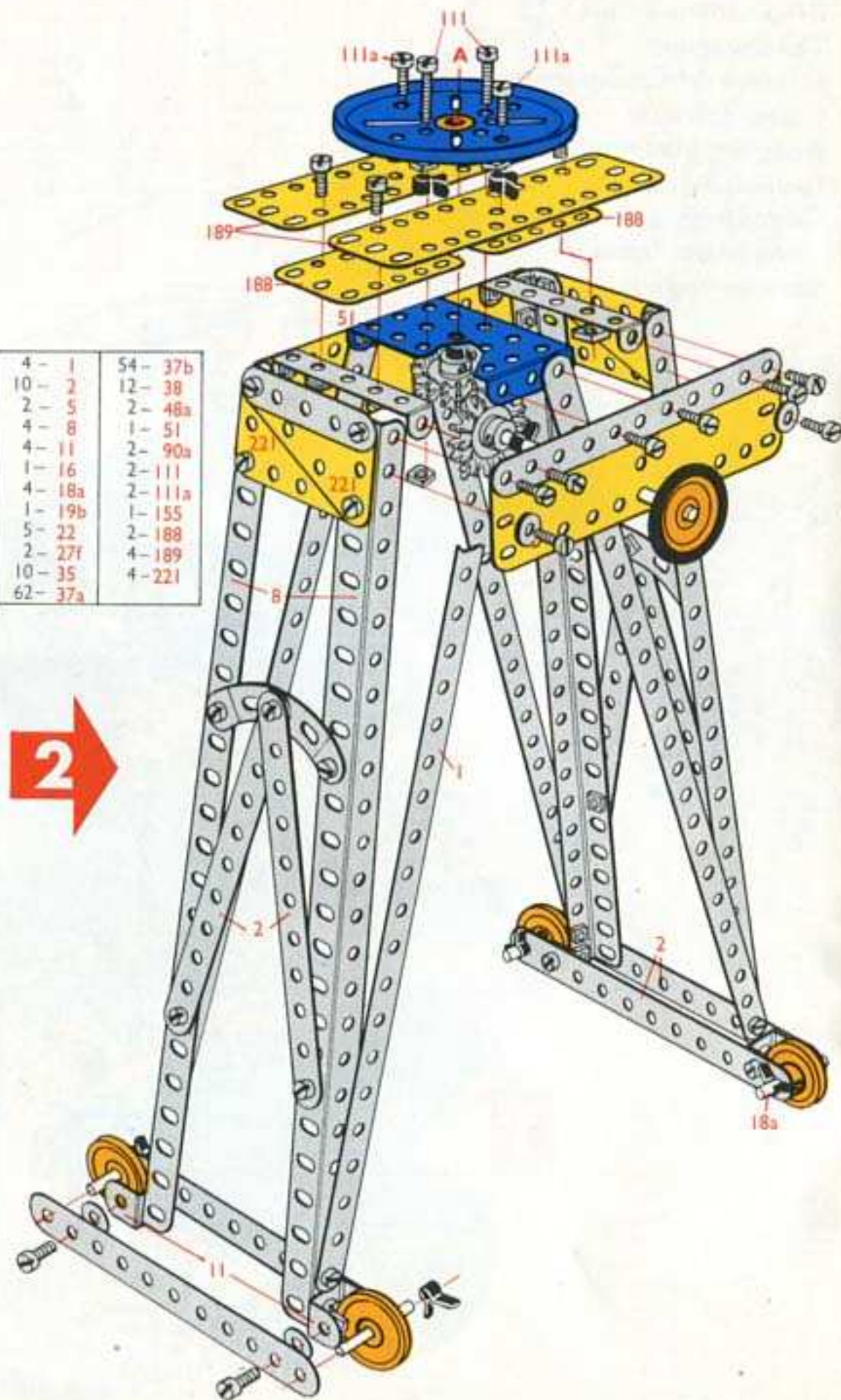

| | | | | | | | |
|-----|-----|------|-----|----|------|----|------|
| 10- | 1 | 1- | 19s | 2- | 38d | 2- | 126a |
| 14- | 2* | 1- | 20a | 1- | 40 | 1- | 147b |
| 2- | 3 | 5- | 22 | 2- | 48 | 1- | 155 |
| 9- | 5 | 2- | 22a | 8- | 48a | 1- | 176 |
| 2- | 6a | 1- | 23 | 1- | 51 | 4- | 188 |
| 4- | 8 | 1- | 23a | 1- | 52 | 4- | 189 |
| 4- | 11 | 2- | 24 | 2- | 53a | 2- | 190 |
| 1- | 11a | 1- | 26 | 2- | 54 | 2- | 191 |
| 4- | 12 | 1- | 27a | 1- | 57c | 1- | 192 |
| 1- | 15b | 2- | 27f | 2- | 90a | 2- | 193 |
| 3- | 16 | 13- | 35 | 2- | 111 | 1- | 193a |
| 2- | 17 | 137- | 37a | 4- | 111a | 1- | 213 |
| 4- | 18a | 117- | 37b | 1- | 111c | 2- | 214 |
| 2- | 19b | 24- | 38 | 1- | 115 | 4- | 221 |

| | |
|-----|------|
| 6- | 1 |
| 2- | 3 |
| 4- | 5 |
| 2- | 6a |
| 1- | 11a |
| 4- | 12 |
| 1- | 15b |
| 1- | 23 |
| 1- | 23a |
| 2- | 24 |
| 31- | 37a |
| 25- | 37b |
| 5- | 38 |
| 1- | 48 |
| 2- | 48a |
| 2- | 54 |
| 1- | 57c |
| 2- | 111a |
| 1- | 115 |
| 2- | 126a |
| 1- | 147b |

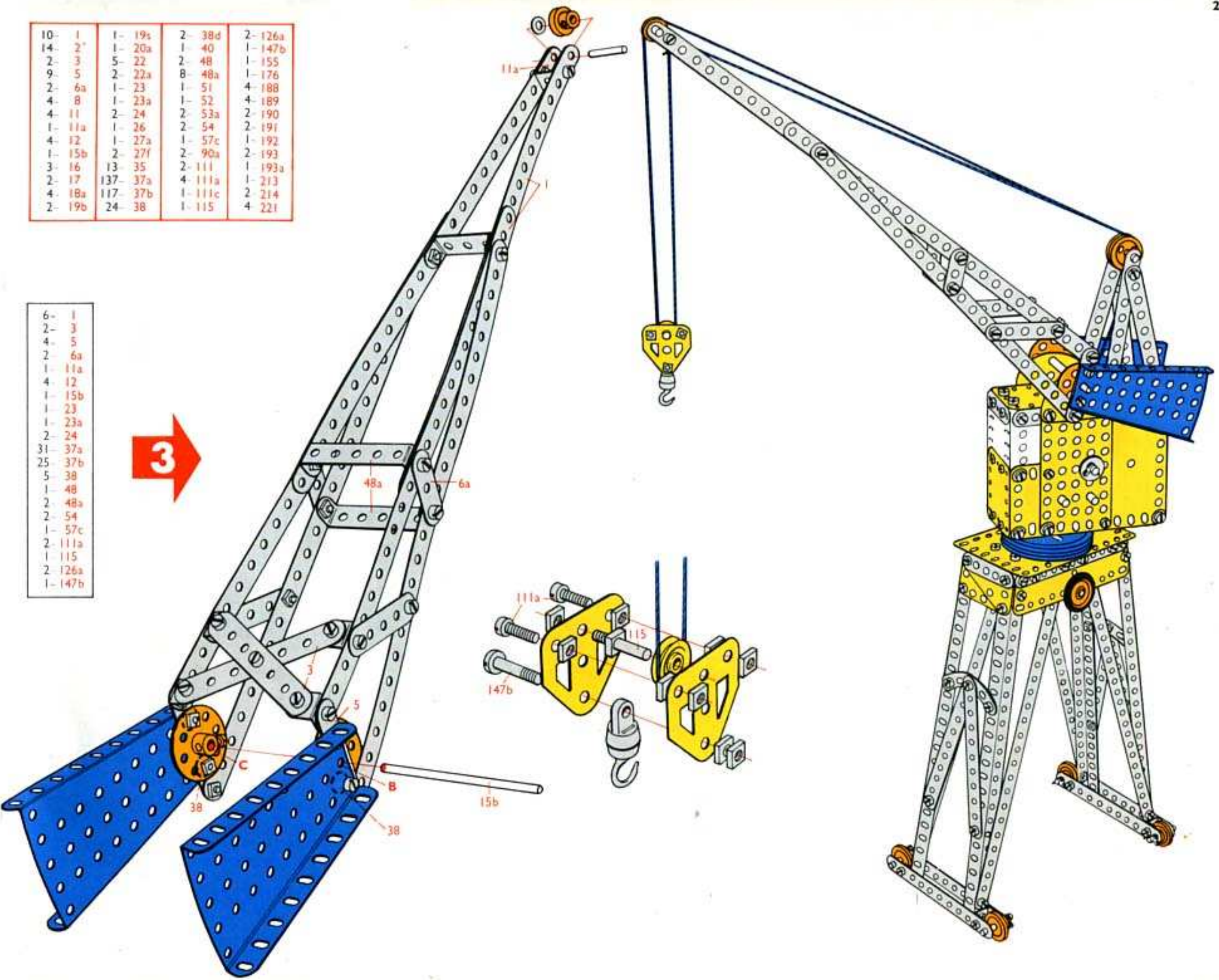

6.3.

Coasting Steamer

Stoomboot

Vapeur cotier

Piroscafo da cabotaggio

Küstenschiff

Kustangare

Buque de cabotaje

Barco de Cabotagem

Kystbat

| | | | |
|------|-----|----|------|
| 4- | 1 | 2- | 53a |
| 6- | 2 | 1- | 54 |
| 2- | 3 | 1- | 57c |
| 12- | 5 | 4- | 90a |
| 2- | 6a | 1- | 111 |
| 4- | 10 | 2- | 111a |
| 1- | 11a | 2- | 111c |
| 11- | 12 | 1- | 115 |
| 2- | 12a | 2- | 125 |
| 8- | 12c | 2- | 126 |
| 2- | 15 | 2- | 126a |
| 1- | 15a | 4- | 142c |
| 1- | 16 | 1- | 147b |
| 1- | 17 | 1- | 155 |
| 1- | 18b | 1- | 176 |
| 5- | 22 | 3- | 188 |
| 1- | 23 | 4- | 189 |
| 1- | 23a | 4- | 190 |
| 1- | 24 | 2- | 191 |
| 1- | 26 | 4- | 192 |
| 6- | 35 | 2- | 193 |
| 130- | 37a | 2- | 193a |
| 122- | 37b | 2- | 194 |
| 24- | 38 | 2- | 194a |
| 1- | 38d | 1- | 200 |
| 1- | 40 | 1- | 212 |
| 2- | 48 | 2- | 214 |
| 8- | 48a | 4- | 215 |
| 1- | 51 | 2- | 221 |
| 1- | 52 | 2- | 222 |

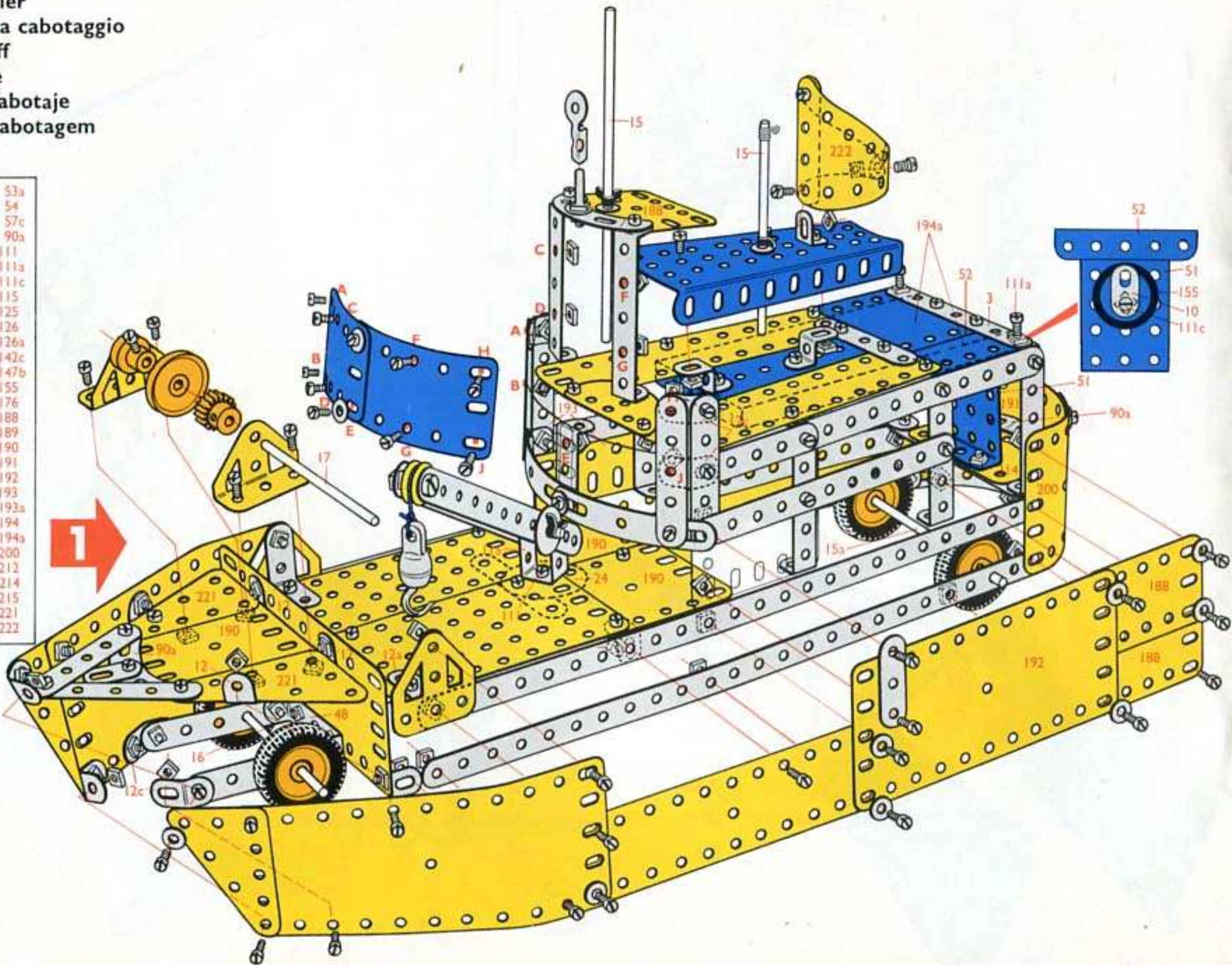

| | | | |
|--------|----------|---------|---------|
| 4- 1 | 5- 22 | 2- 53a | 3- 188 |
| 6- 2 | 1- 23 | 1- 54 | 4- 189 |
| 2- 3 | 1- 23b | 1- 57c | 4- 190 |
| 12- 5 | 1- 24 | 4- 90a | 2- 191 |
| 2- 6a | 1- 26 | 1- 111 | 4- 192 |
| 4- 10 | 6- 35 | 2- 111a | 2- 193 |
| 1- 11a | 130- 37a | 2- 111c | 2- 193a |
| 11- 12 | 122- 37b | 1- 115 | 2- 194 |
| 2- 12a | 24- 38 | 2- 125 | 2- 194a |
| 8- 12c | 1- 38d | 2- 126 | 1- 200 |
| 2- 15 | 1- 40 | 2- 126a | 1- 212 |
| 1- 15a | 2- 48 | 4- 142c | 2- 214 |
| 1- 16 | 8- 48a | 1- 147b | 4- 215 |
| 1- 17 | 1- 51 | 1- 155 | 2- 221 |
| 1- 18b | 1- 52 | 1- 176 | 2- 222 |

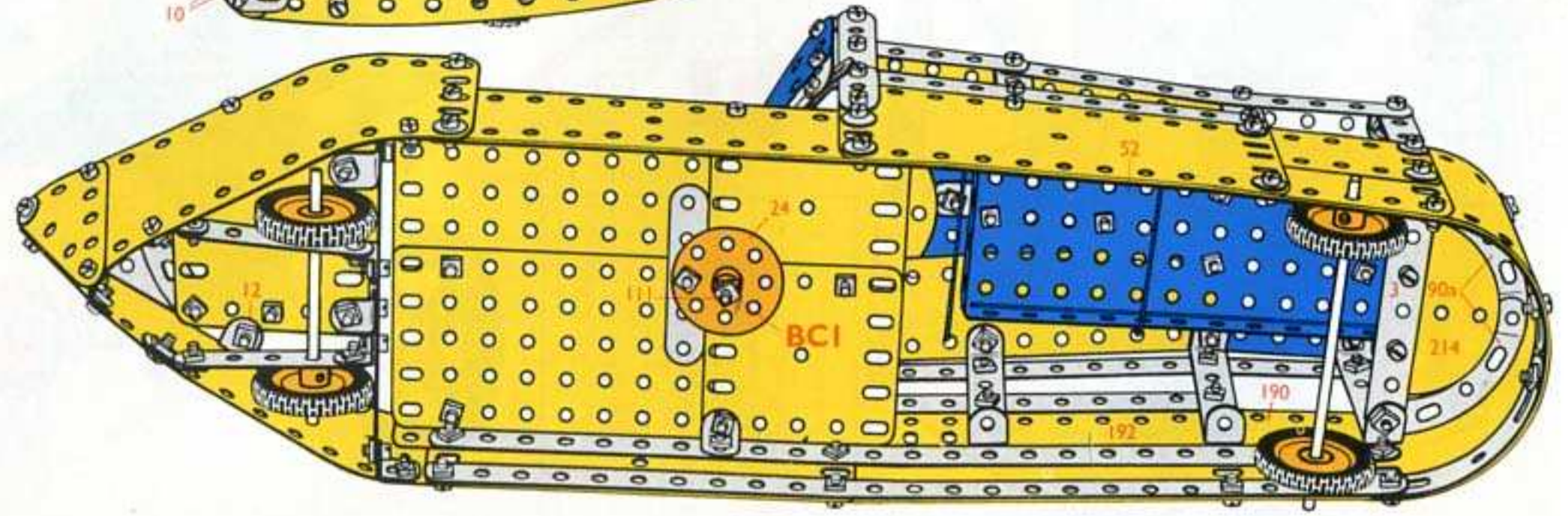
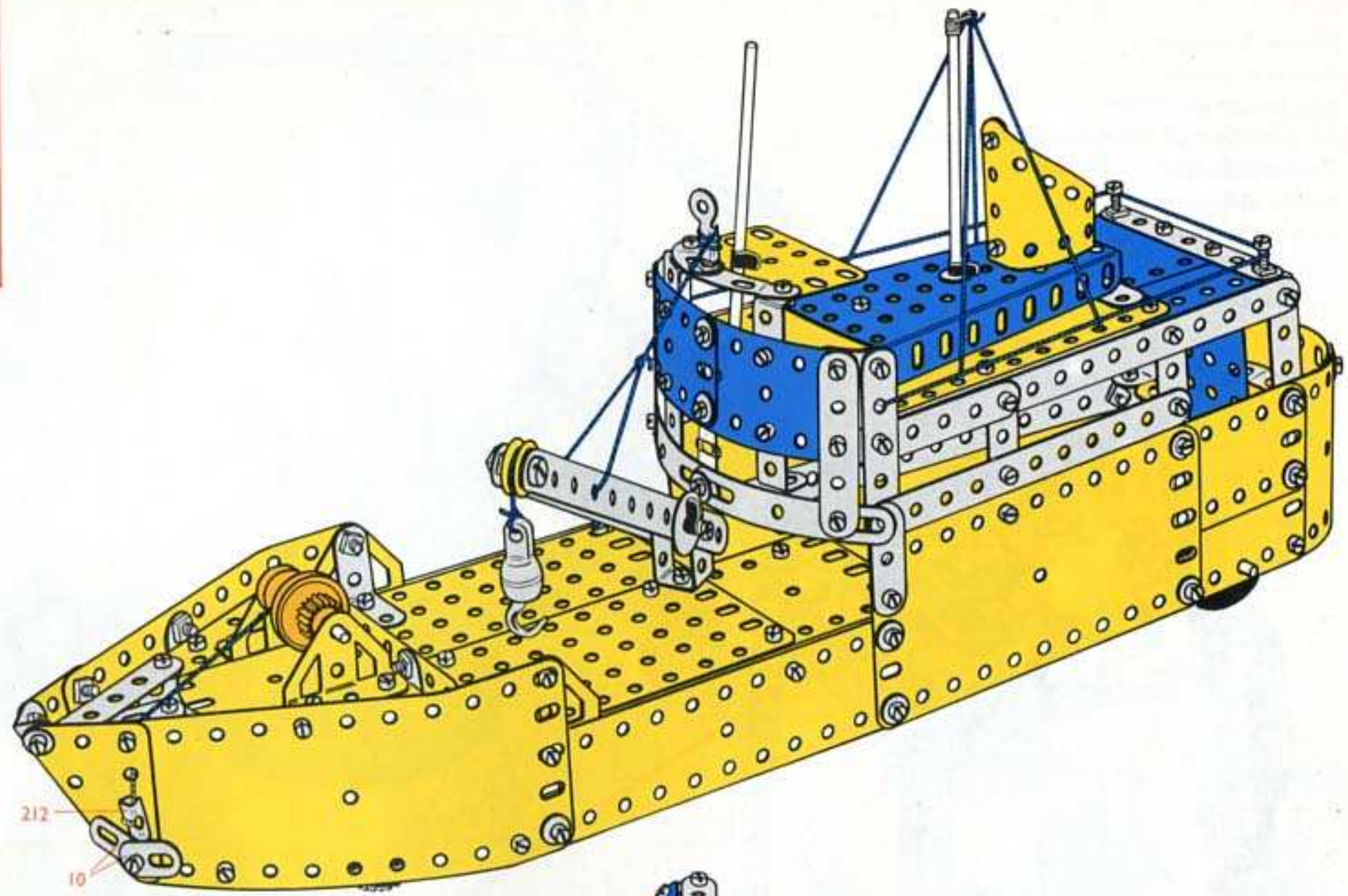

6.4.

Radar Scanner
 Radarscanner
 Explorateur radar
 Dispositivo di esplorazione radar
 Radarabtaster
 Radarantenn
 Explorador de radar
 Explorador de Radar
 Radarsoker

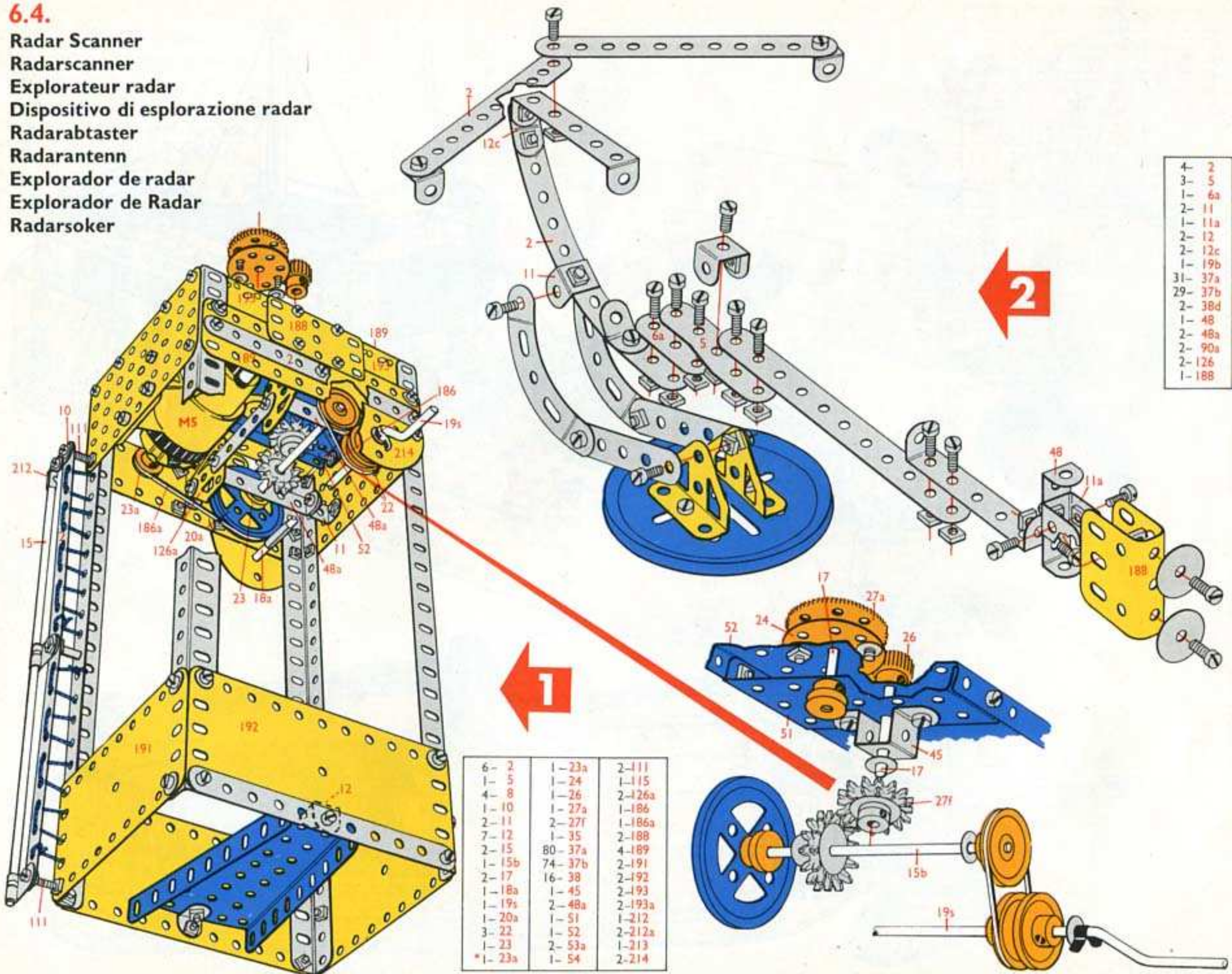

| | |
|-----|-----|
| 4- | 2 |
| 3- | 5 |
| 1- | 6a |
| 2- | 11 |
| 1- | 11a |
| 2- | 12 |
| 2- | 12c |
| 1- | 19b |
| 31- | 37a |
| 29- | 37b |
| 2- | 38d |
| 1- | 48 |
| 2- | 48a |
| 2- | 90a |
| 2- | 126 |
| 1- | 188 |

| | | | | | |
|-----|-----|-----|-----|----|------|
| 6- | 2 | 1- | 23a | 2- | 11 |
| 1- | 5 | 1- | 24 | 1- | 115 |
| 4- | 8 | 1- | 26 | 2- | 126a |
| 1- | 10 | 1- | 27a | 1- | 186 |
| 2- | 11 | 2- | 27f | 1- | 186a |
| 7- | 12 | 1- | 35 | 2- | 188 |
| 2- | 15 | 80- | 37a | 4- | 189 |
| 1- | 15b | 74- | 37b | 2- | 191 |
| 2- | 17 | 16- | 38 | 2- | 192 |
| 1- | 18a | 1- | 45 | 2- | 193 |
| 1- | 19s | 2- | 48a | 2- | 193a |
| 1- | 20a | 1- | 51 | 1- | 212 |
| 3- | 22 | 1- | 52 | 2- | 212a |
| 1- | 23 | 2- | 53a | 1- | 213 |
| *1- | 23a | 1- | 54 | 2- | 214 |

| | | | | | | | |
|-----|-----|------|-----|----|------|----|------|
| 10- | 1 | 1- | 19b | 1- | 40 | 1- | 186a |
| 14- | 2 | 1- | 19s | 1- | 45 | 4- | 188 |
| 2- | 3 | 1- | 20a | 1- | 48 | 4- | 189 |
| 12- | 5 | 3- | 22 | 6- | 48a | 2- | 191 |
| 1- | 6a | 1- | 23 | 1- | 51 | 2- | 192 |
| 4- | 8 | 4- | 23a | 1- | 52 | 2- | 193 |
| 1- | 10 | 1- | 23a | 2- | 53a | 2- | 193a |
| 4- | 11 | 1- | 24 | 1- | 54 | 1- | 212 |
| 1- | 11a | 1- | 26 | 2- | 80c | 2- | 212a |
| 9- | 12 | 1- | 27a | 2- | 90a | 1- | 213 |
| 2- | 12a | 2- | 27f | 2- | 111 | 2- | 214 |
| 2- | 12c | 5- | 35 | 4- | 111c | 4- | 221 |
| 2- | 15 | 144- | 37a | 1- | 115 | 4- | M5 |
| 1- | 15b | 133- | 37b | 2- | 126 | | |
| 2- | 17 | 16- | 38 | 2- | 126a | | |
| 1- | 18a | 2- | 38d | 1- | 186 | | |

• Not included in set No. 6

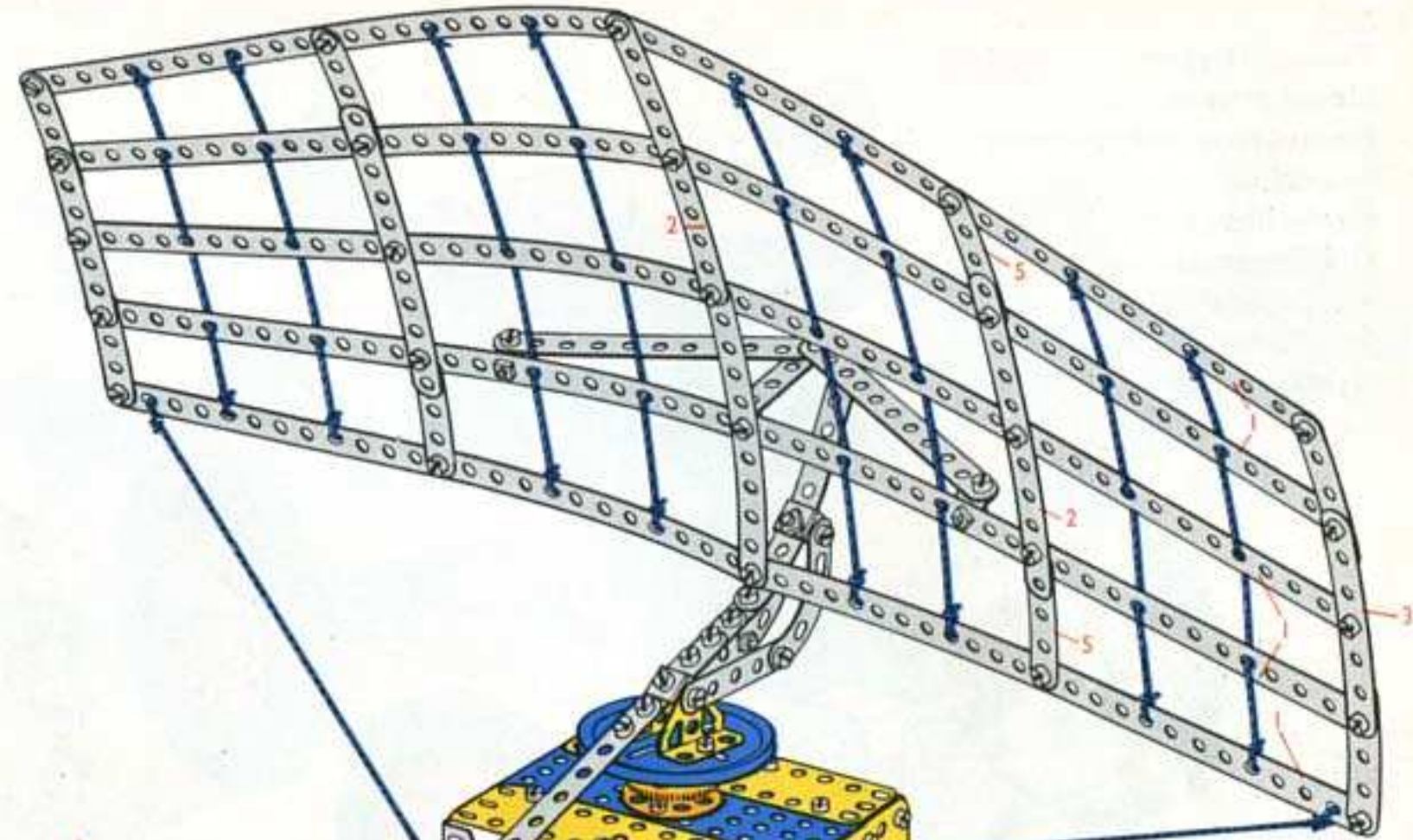

| | |
|-----|-----|
| 10- | 1 |
| 4- | 2 |
| 2- | 4 |
| 8- | 5 |
| 27- | 37a |
| 27- | 37b |
| 1- | 40 |

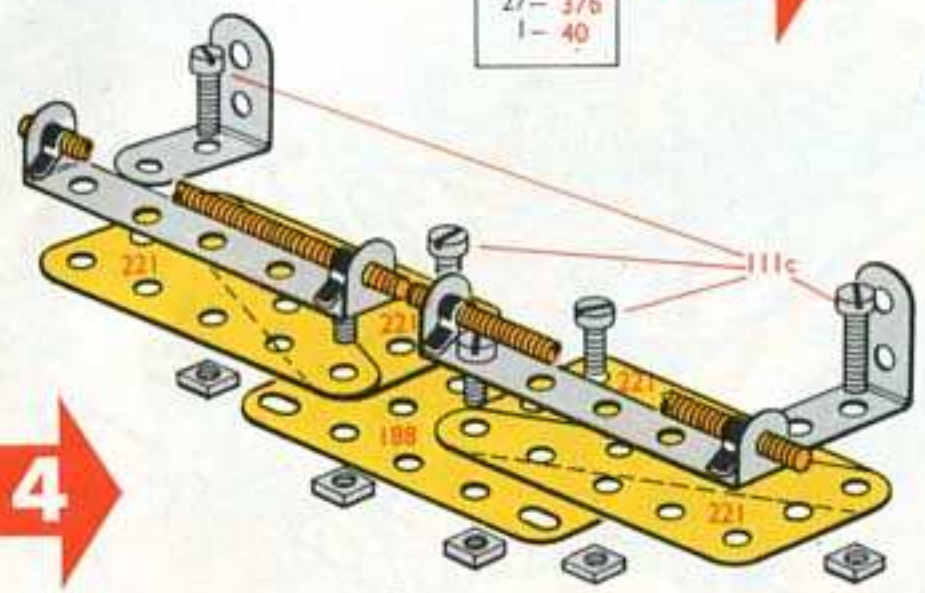

| | |
|----|------|
| 2- | 12a |
| 4- | 35 |
| 6- | 37a |
| 4- | 37b |
| 2- | 48a |
| 2- | 80c |
| 4- | 111c |
| 1- | 188 |
| 4- | 221 |

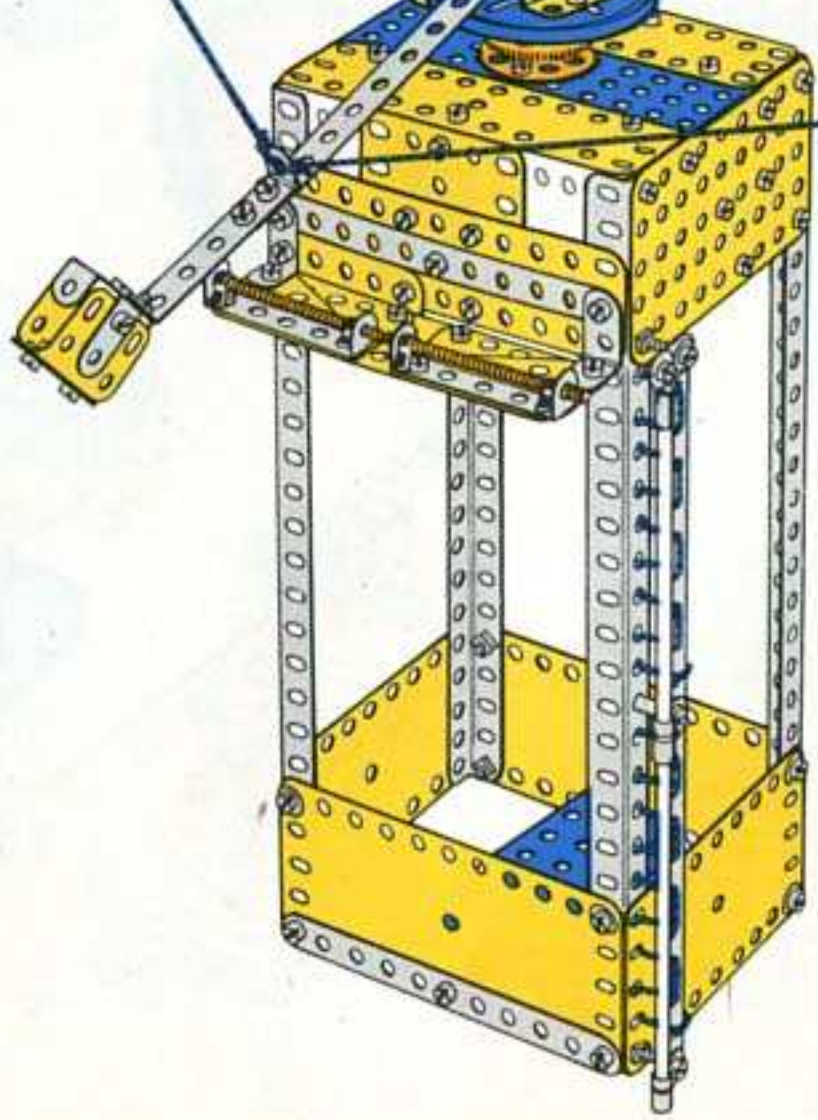

6.5.

Trench Digger
 Slotenraver
 Excavateur de tranchées
 Scavafossi
 Grabenbagger
 Dikningsmaskin
 Zanjadora
 Escavadora de Valas
 Grøftegraver

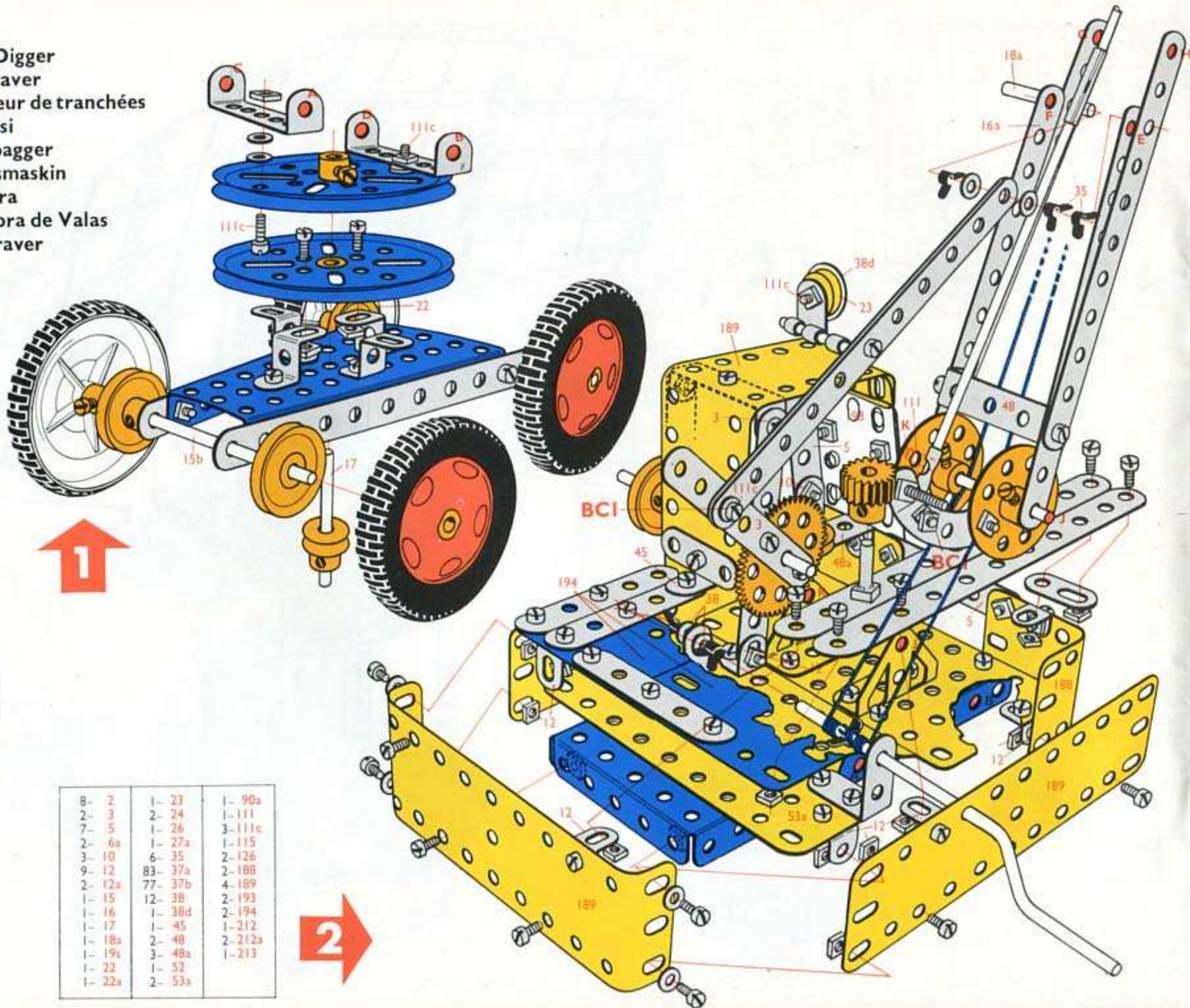

- 2- 2
- 1- 15a
- 1- 15b
- 1- 17
- 2- 19b
- 4- 22
- 1- 23a
- 12- 37a
- 10- 37b
- 4- 38
- 2- 48a
- 1- 54
- 2- 111c
- 4- 125
- 4- 187



| | | |
|--------|---------|---------|
| 8- 2 | 1- 23 | 1- 90a |
| 2- 3 | 2- 24 | 1- 111 |
| 7- 5 | 1- 26 | 3- 111c |
| 2- 6a | 1- 27a | 1- 115 |
| 3- 10 | 6- 35 | 2- 126 |
| 9- 12 | 83- 37a | 2- 188 |
| 2- 12a | 77- 37b | 4- 189 |
| 1- 15 | 12- 38 | 2- 193 |
| 1- 16 | 1- 38d | 2- 194 |
| 1- 17 | 1- 45 | 1- 212 |
| 1- 18a | 2- 48 | 2- 212a |
| 1- 19a | 3- 48a | 1- 213 |
| 1- 22 | 1- 52 | |
| 1- 22a | 2- 53a | |



| | | | |
|--------|----------|---------|---------|
| 14- 2 | 2- 18a | 1- 38d | 2- 126 |
| 2- 3 | 2- 19b | 1- 40 | 4- 187 |
| 12- 5 | 1- 19a | 1- 45 | 4- 188 |
| 2- 6a | 5- 22 | 2- 48 | 4- 189 |
| 3- 10 | 1- 22a | 7- 48a | 2- 193 |
| 3- 11 | 1- 23 | 1- 51 | 2- 194 |
| 1- 11a | 1- 23a | 1- 52 | 1- 200 |
| 11- 12 | 2- 24 | 2- 53a | 2- 212 |
| 2- 12a | 1- 26 | 1- 54 | 2- 212a |
| 2- 15 | 1- 27a | 1- 90a | 1- 213 |
| 1- 15a | 8- 35 | 1- 111 | 2- 214 |
| 1- 15b | 136- 37a | 3- 111c | 4- 221 |
| 1- 16 | 126- 37b | 1- 115 | |
| 2- 17 | 18- 38 | 4- 125 | |

| | |
|---------|--------|
| 4- 2 | 2- 38 |
| 5- 5 | 1- 40 |
| 3- 11 | 4- 48a |
| 1- 11a | 1- 51 |
| 2- 12 | 2- 188 |
| 1- 15 | 1- 200 |
| 1- 18a | 1- 212 |
| 2- 35 | 2- 214 |
| 41- 37a | 4- 221 |
| 39- 37b | |

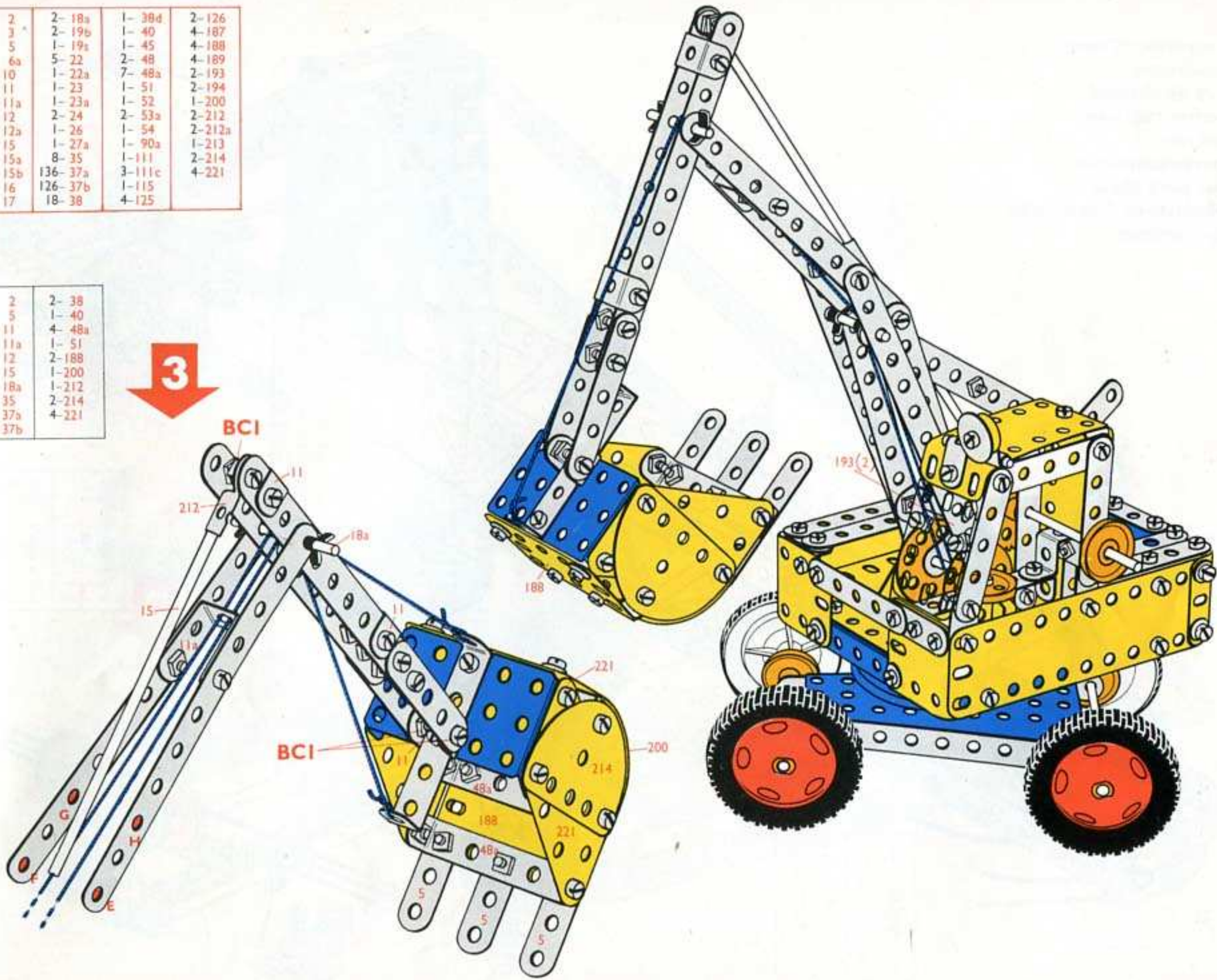

6.6.

Contractors Crane
 Bouwkraan
 Grue de chantier
 Gru per cantiere
 Baukran
 Entreprenörskran
 Grúa para obras
 Guindaste de Construção
 Bygningskran

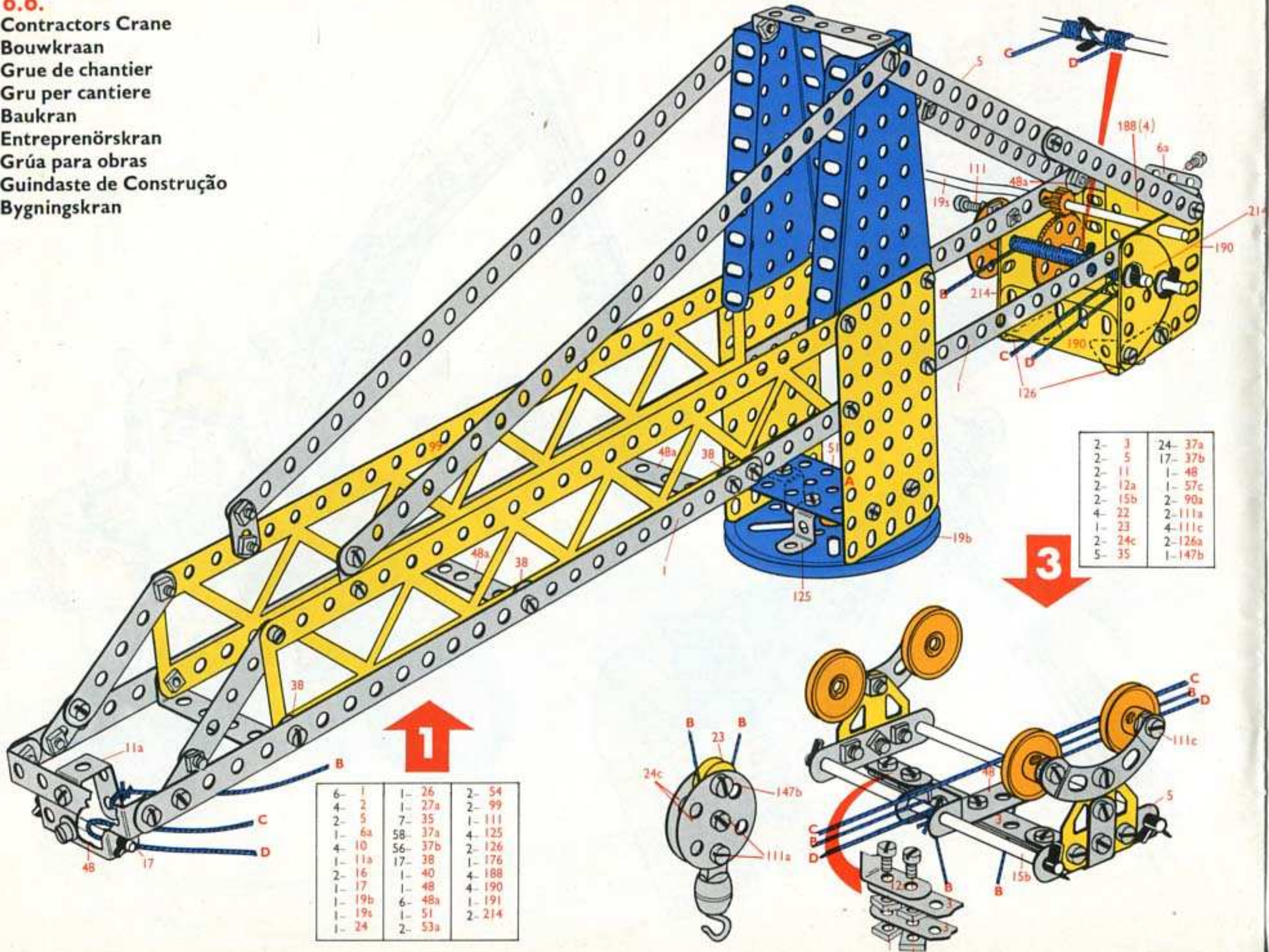

| | | | |
|--------|----------|----------|--------|
| 10- 1- | 1- 17 | 129- 37b | 2-111a |
| 14- 2 | 2- 19b | 18- 38 | 6-111c |
| 2- 3 | 1- 19a | 1- 40 | 1-115 |
| 12- 5 | 5- 22 | 2- 48 | 4-125 |
| 1- 6a | 1- 23 | 8- 48a | 2-126 |
| 4- 8 | 1- 23a | 1- 51 | 2-126a |
| 4- 10 | 2- 24 | 1- 52 | 1-147b |
| 2- 11 | 2- 24c | 2- 53a | 1-176 |
| 1- 11a | 1- 26 | 2- 54 | 4-188 |
| 8- 12 | 1- 27a | 1- 57c | 4-190 |
| 2- 12a | 2- 27f | 4- 90a | 1-191 |
| 2- 15b | 12- 35 | 2- 99 | 4-192 |
| 4- 16 | 142- 37a | 1-111 | 2-214 |

| |
|---------|
| 4- 1 |
| 10- 2 |
| 8- 5 |
| 4- 8 |
| 8- 12 |
| 2- 16 |
| 1- 19b |
| 1- 22 |
| 1- 23a |
| 1- 24 |
| 2- 27f |
| 60- 37a |
| 56- 37b |
| 1- 39 |
| 2- 48a |
| 1- 52 |
| 2- 90a |
| 2-111c |
| 1-115 |
| 4-192 |

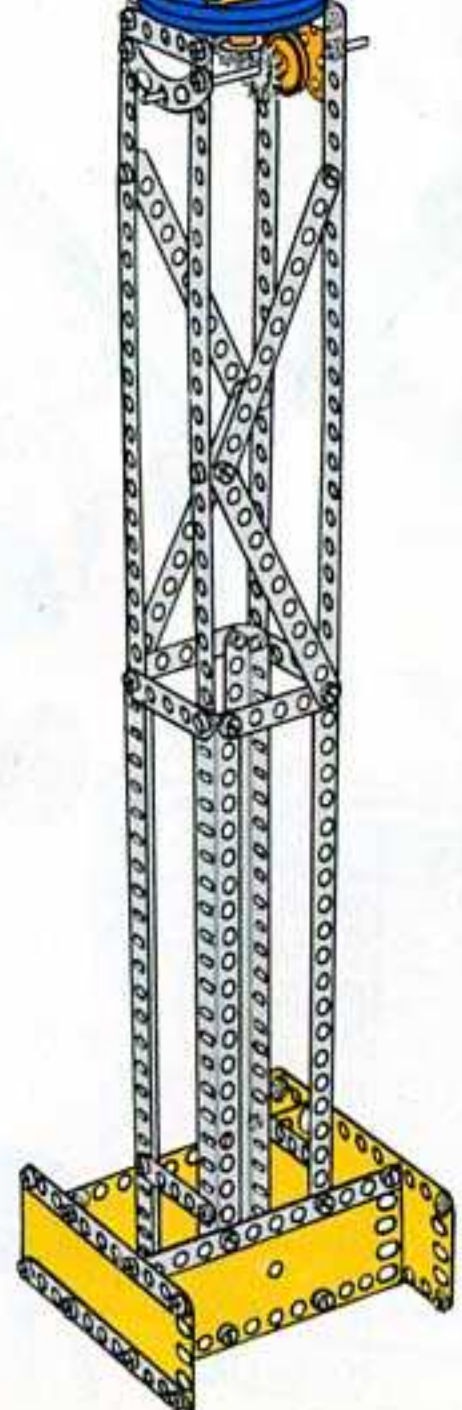
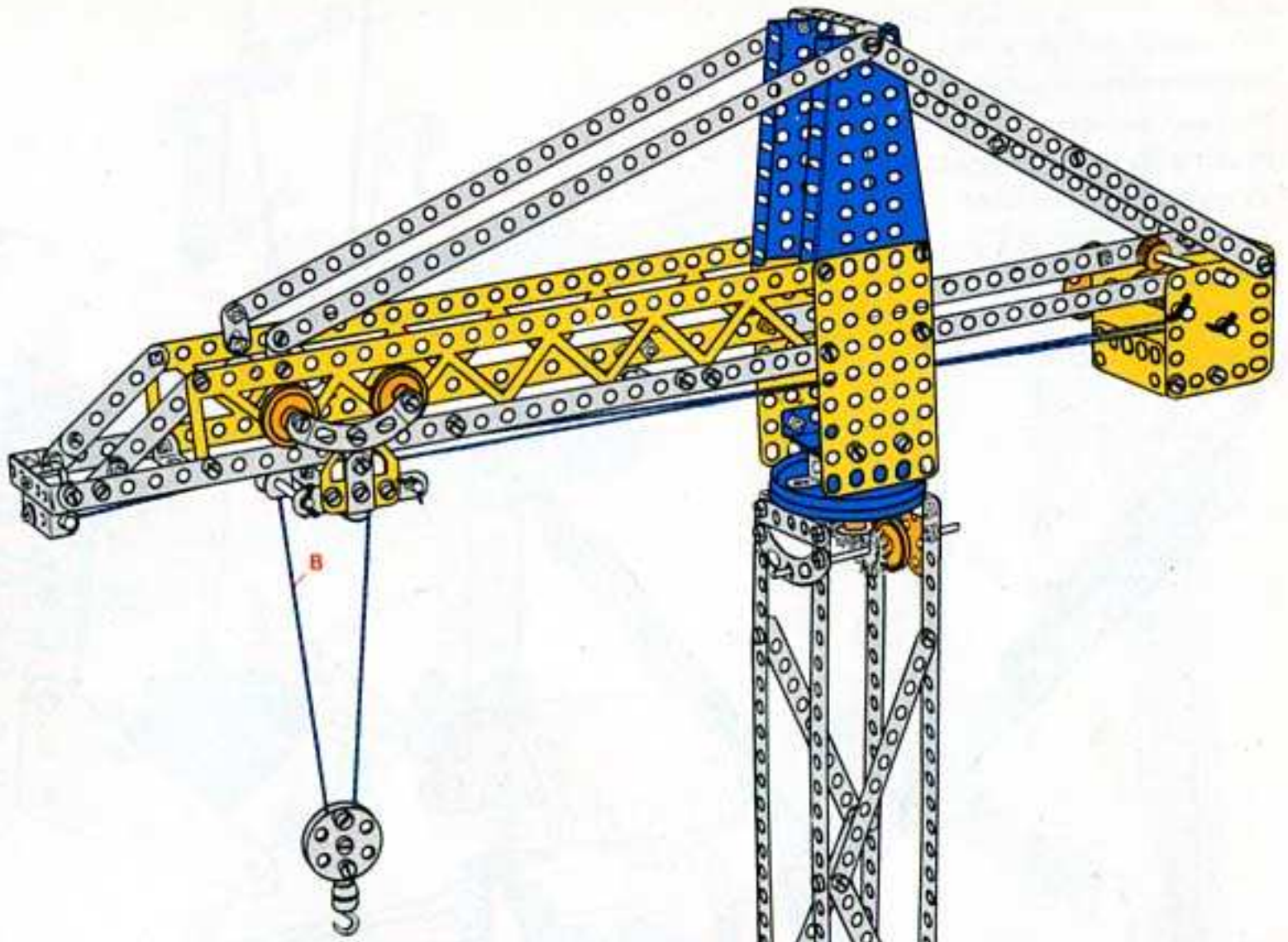
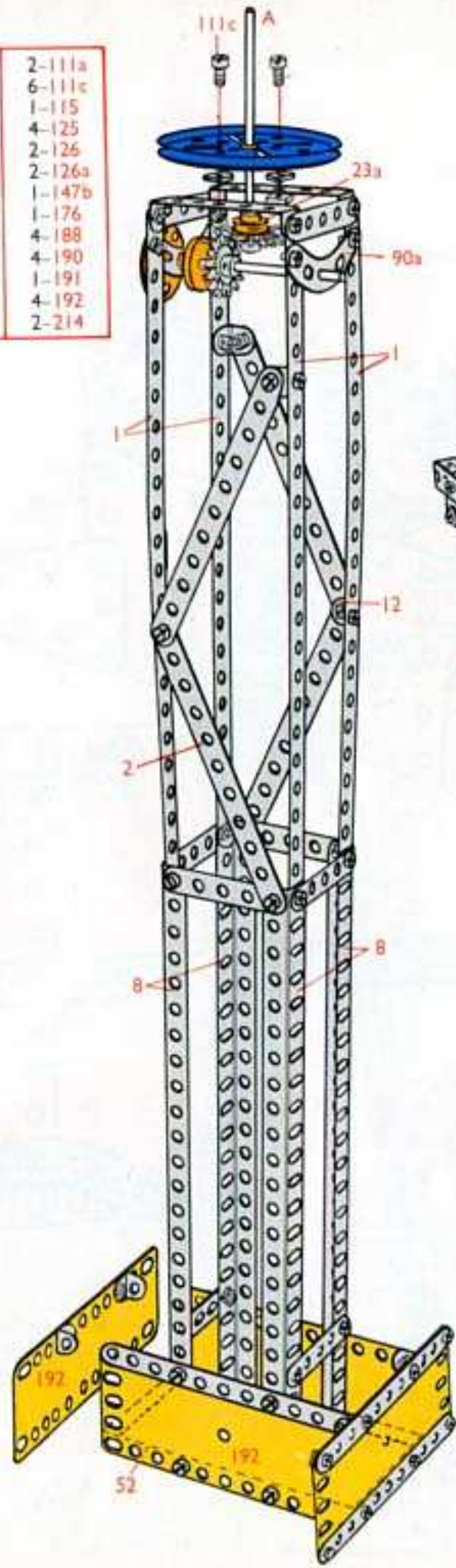

6.7.

Windmill Generator
Windmolengenerator
Moteur éolien
Mulinello per generatore
Windkraftgenerator
Vindgenerator
Aeromotor
Gerador de Moinho
Vindmølle generator

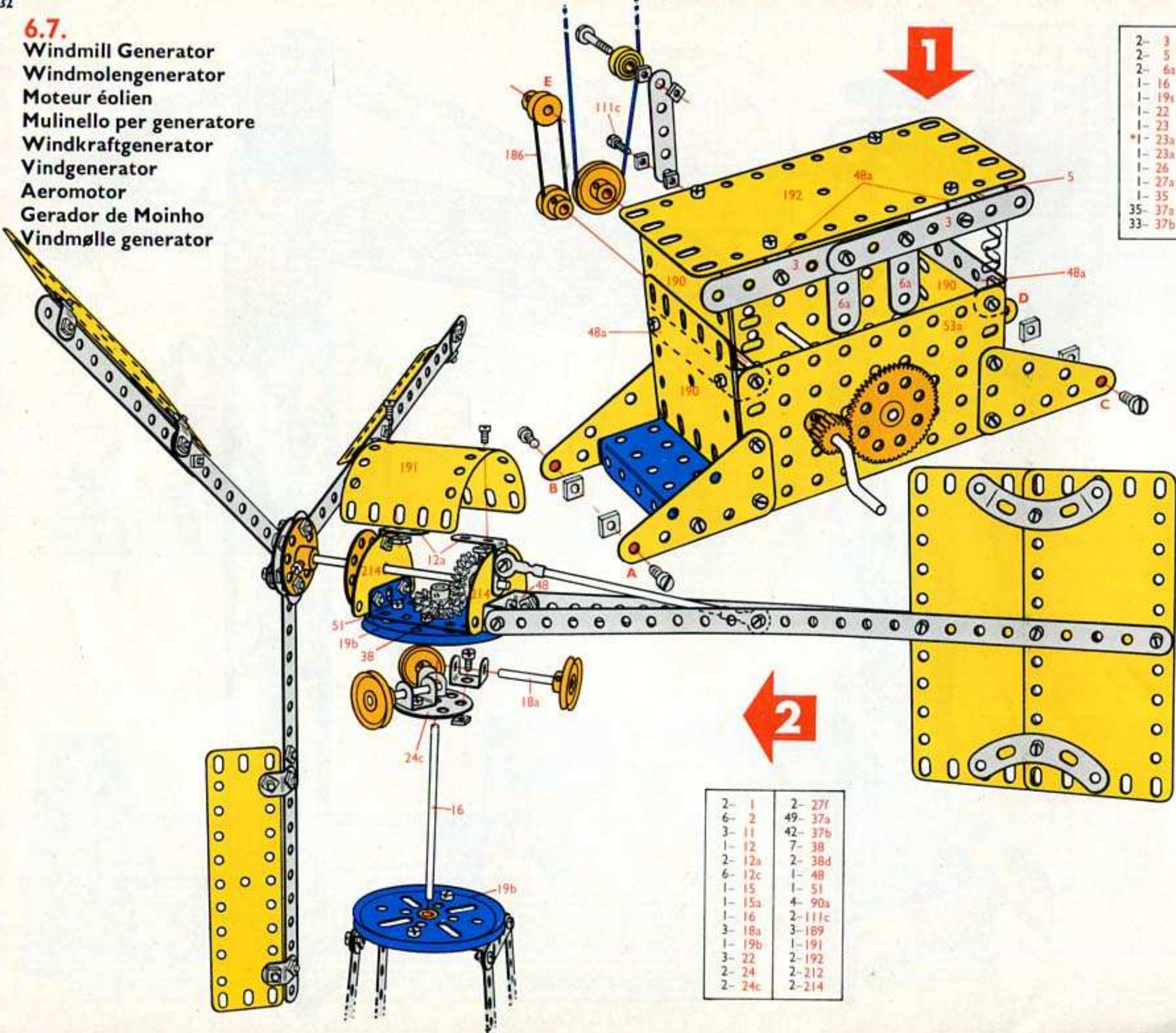

| | | | |
|-----|-----|----|------|
| 2- | 3 | 4- | 38 |
| 2- | 5 | 4- | 48a |
| 2- | 6a | 1- | 52 |
| 1- | 16 | 2- | 53a |
| 1- | 19a | 1- | 111c |
| 1- | 22 | 1- | 115 |
| 1- | 23 | 1- | 147b |
| *1- | 23a | 1- | 186 |
| 1- | 23a | 3- | 190 |
| 1- | 26 | 1- | 191 |
| 1- | 27a | 1- | 192 |
| 1- | 35 | 1- | 193 |
| 35- | 37a | 1- | 193c |
| 33- | 37b | 4- | 221 |

| | | | |
|----|-----|-----|------|
| 2- | 1 | 2- | 27f |
| 6- | 2 | 49- | 37a |
| 3- | 11 | 42- | 37b |
| 1- | 12 | 7- | 38 |
| 2- | 12a | 2- | 38d |
| 6- | 12c | 1- | 48 |
| 1- | 15 | 1- | 51 |
| 1- | 15a | 4- | 90a |
| 1- | 16 | 2- | 111c |
| 3- | 18a | 3- | 189 |
| 1- | 19b | 1- | 191 |
| 3- | 22 | 2- | 192 |
| 2- | 24 | 2- | 212 |
| 2- | 24c | 2- | 214 |

| | | | |
|-------|---------|----------|--------|
| 10- 1 | 2- 19b | 143- 37a | 1-147b |
| 14- 2 | 1- 19a | 134- 37b | 1-186 |
| 2- 3 | 1- 20a | 15- 38 | *1-186 |
| 12- 5 | 4- 22 | 2- 38d | 3-189 |
| 2- 6a | 2- 22a | 1- 40 | 3-190 |
| 4- 8 | 1- 23 | 1- 48 | 2-191 |
| 3-11 | *1- 23a | 8- 48a | 3-192 |
| 5-12 | 1- 23a | 1- 51 | 1-193 |
| 2-12a | 2- 24 | 1- 52 | 1-193c |
| 6-12c | 2- 24c | 2- 53a | 2-212 |
| 1- 15 | 1- 26 | 4- 90a | 2-214 |
| 1-15a | 1- 27a | 3-111c | 4-221 |
| 3- 16 | 2- 27f | 1-115 | *1-M2 |
| 3-18a | 5- 35 | 2-125 | |

*Not included in set

| | |
|--------|---------|
| 8- 1 | 2- 22a |
| 8- 2 | 4- 35 |
| 10- 5 | 59- 37a |
| 4- 8 | 59- 37b |
| 4-12 | 4- 38 |
| 1- 16 | 1- 40 |
| 1-19b | 4- 48a |
| 1- 20a | 2-125 |

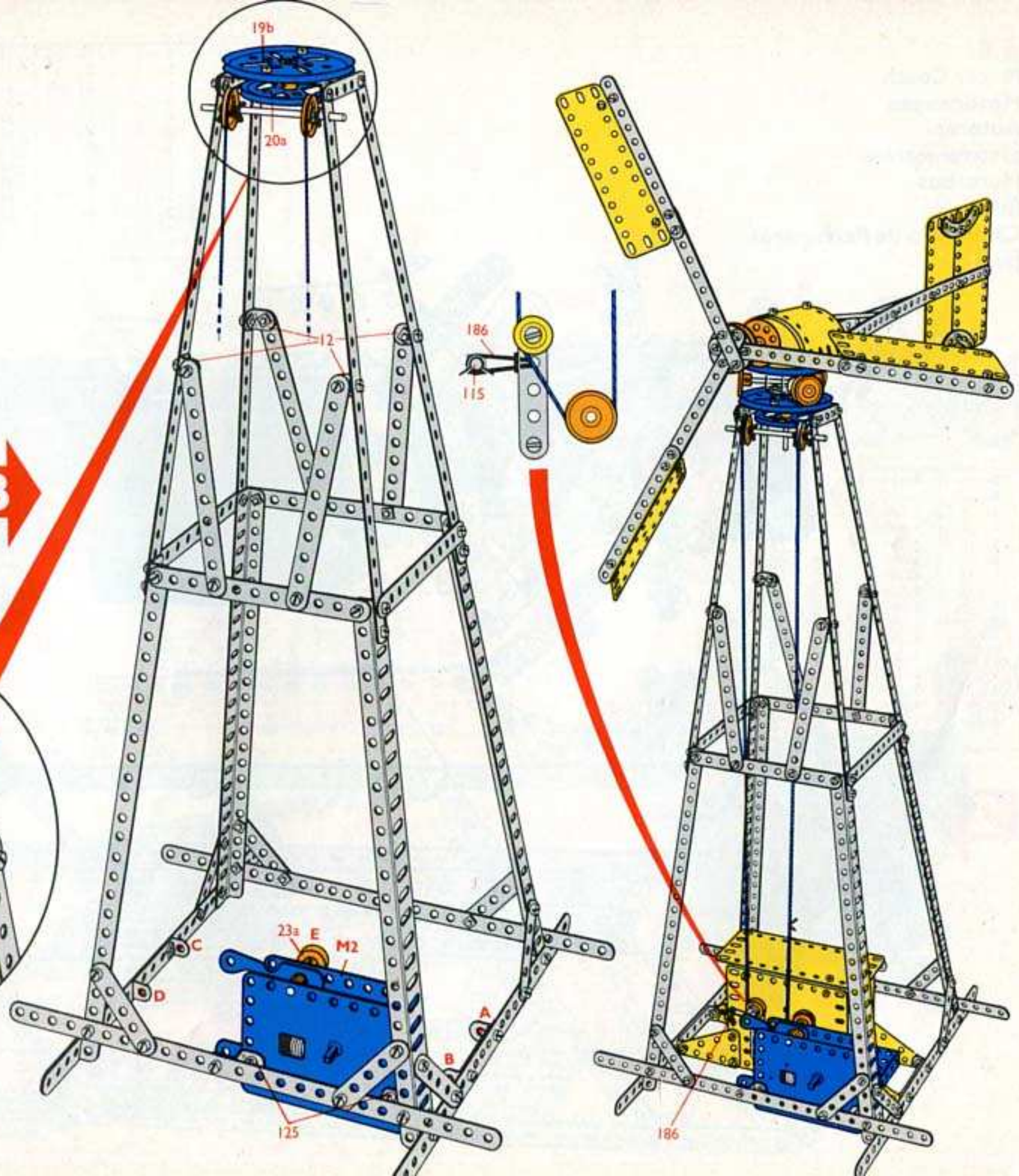
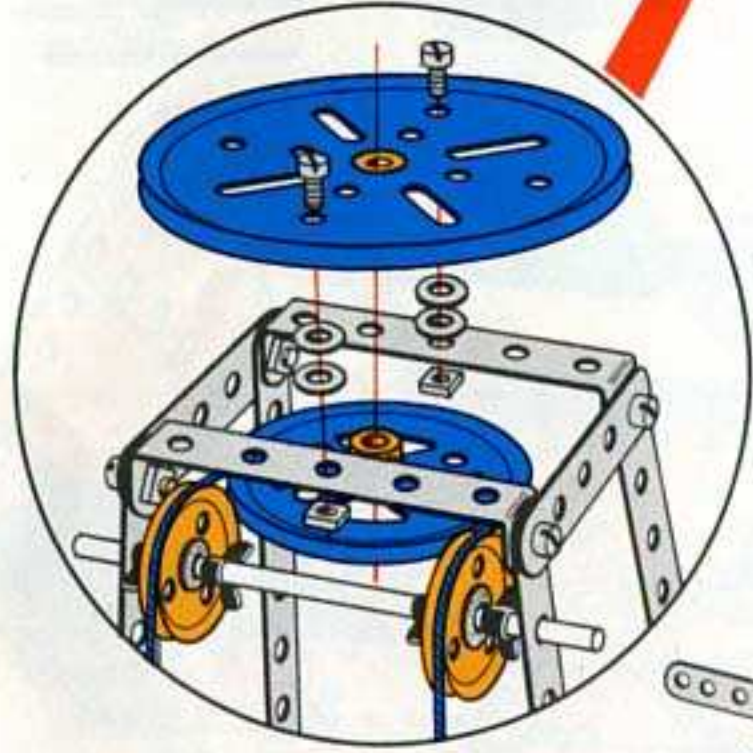

19b

20a

12

186

115

23a

E

M2

125

186

6.8.

Motor Coach
 Motorwagen
 Autocar
 Elettromotrice
 Motorbus
 Buss
 Camioneta de Passageiros
 Buss



| | | |
|---------|---------|----------|
| 2- 3 | 1- 23a | 1- 53a |
| 5- 5 | 2- 24 | 2- 111c |
| 1- 6a | 2- 24c | 2- 125 |
| 4- 8 | 1- 26 | 2- 126 |
| 4- 11 | 1- 27a | 2- 126a |
| 2- 12 | 6- 35 | 1- 155 |
| 2- 12a | 59- 37a | *1- 186a |
| 1- 15 | 51- 37b | 1- 186a |
| 1- 16 | 8- 38 | 4- 187 |
| 2- 17 | 1- 48 | 1- 213 |
| 2- 18a | 3- 48a | 2- 215 |
| 4- 22 | 1- 51 | |
| *1- 23a | 1- 52 | |

| | |
|---------|---------|
| 10- 1 | 4- 111c |
| 8- 2 | 1- 115 |
| 7- 5 | 3- 188 |
| 1- 6a | 4- 189 |
| 2- 10 | 4- 190 |
| 8- 12 | 2- 191 |
| 1- 15 | 4- 192 |
| 1- 35 | 2- 193a |
| 87- 37a | 1- 193c |
| 83- 37b | 1- 193e |
| 2- 38d | 1- 199 |
| 5- 48a | 1- 200 |
| 1- 53a | 2- 212a |
| 2- 54 | 2- 214 |
| 4- 90a | 4- 221 |
| 2- 111 | 1- 222 |
| 3- 111a | |

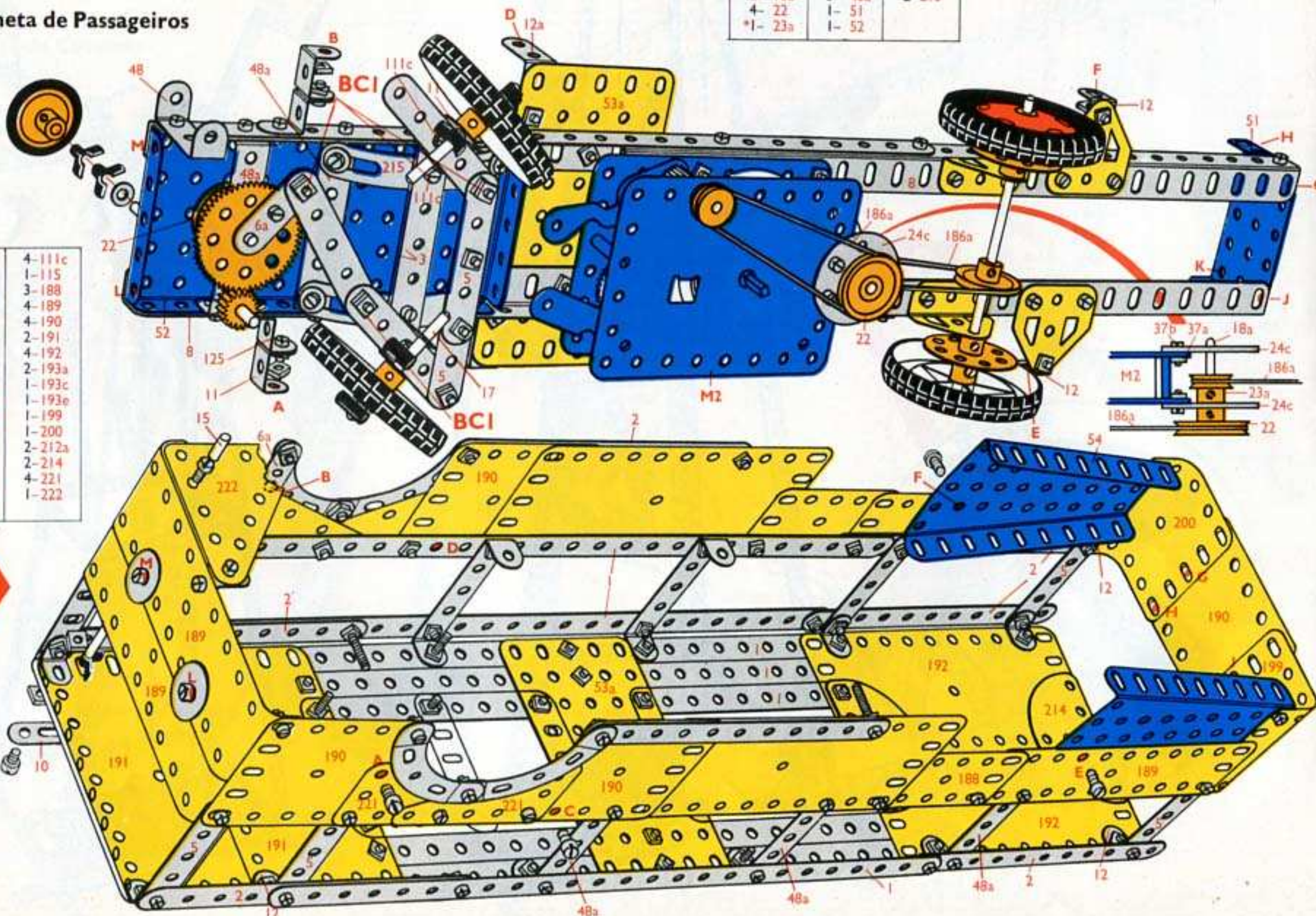

| | | | |
|---------|----------|---------|---------|
| 10- 1 | 1- 23a | 4- 90a | 4- 192 |
| 8- 2 | 2- 24 | 2- 111 | 2- 193a |
| 2- 3 | 2- 24c | 2- 111a | 1- 193c |
| 12- 5 | 1- 26 | 5- 111c | 1- 193e |
| 2- 6a | 1- 27a | 1- 115 | 1- 199 |
| 4- 8 | 7- 35 | 2- 125 | 1- 200 |
| 2- 10 | 146- 37a | 2- 126 | 2- 212a |
| 4- 11 | 134- 37b | 2- 126a | 1- 213 |
| 10- 12 | 8- 38 | 1- 155 | 2- 214 |
| 2- 12a | 2- 38d | 1- 186a | 2- 215 |
| 2- 15 | 1- 48 | 1- 186a | 4- 221 |
| 1- 16 | 8- 48a | 4- 187 | 1- 222 |
| 2- 17 | 1- 51 | 3- 188 | 1- M2 |
| 2- 18a | 1- 52 | 4- 189 | |
| 4- 22 | 2- 53a | 4- 190 | |
| *1- 23a | 2- 54 | 2- 191 | |

*Not included in set

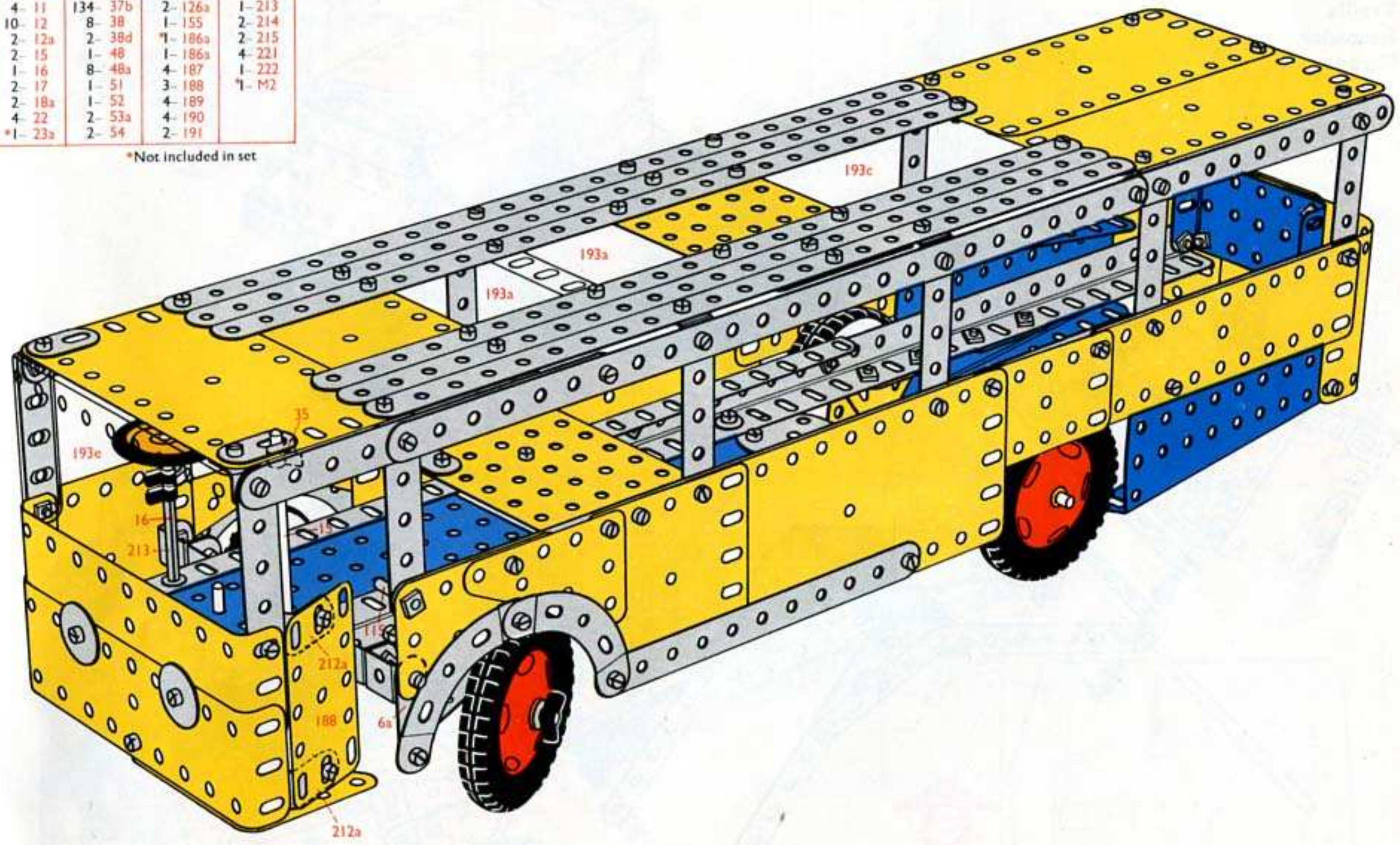

6.9.
 Scraper
 Schrapper
 Schrapper
 Vägskrapa
 Trailla
 Raspador
 Skraper

| | | | |
|-----|-----|----|------|
| 3- | 2 | 2- | 48 |
| 2- | 3 | 2- | 48a |
| 4- | 5 | 2- | 54 |
| 4- | 10 | 4- | 90a |
| 3- | 11 | 2- | 111c |
| 2- | 12 | 3- | 125 |
| 1- | 15 | 2- | 187 |
| 1- | 15b | 2- | 188 |
| 1- | 17 | 4- | 189 |
| 1- | 24 | 1- | 191 |
| 2- | 35 | 1- | 192 |
| 57- | 37a | 2- | 194a |
| 49- | 37b | 1- | 199 |
| 6- | 38 | 1- | 213 |

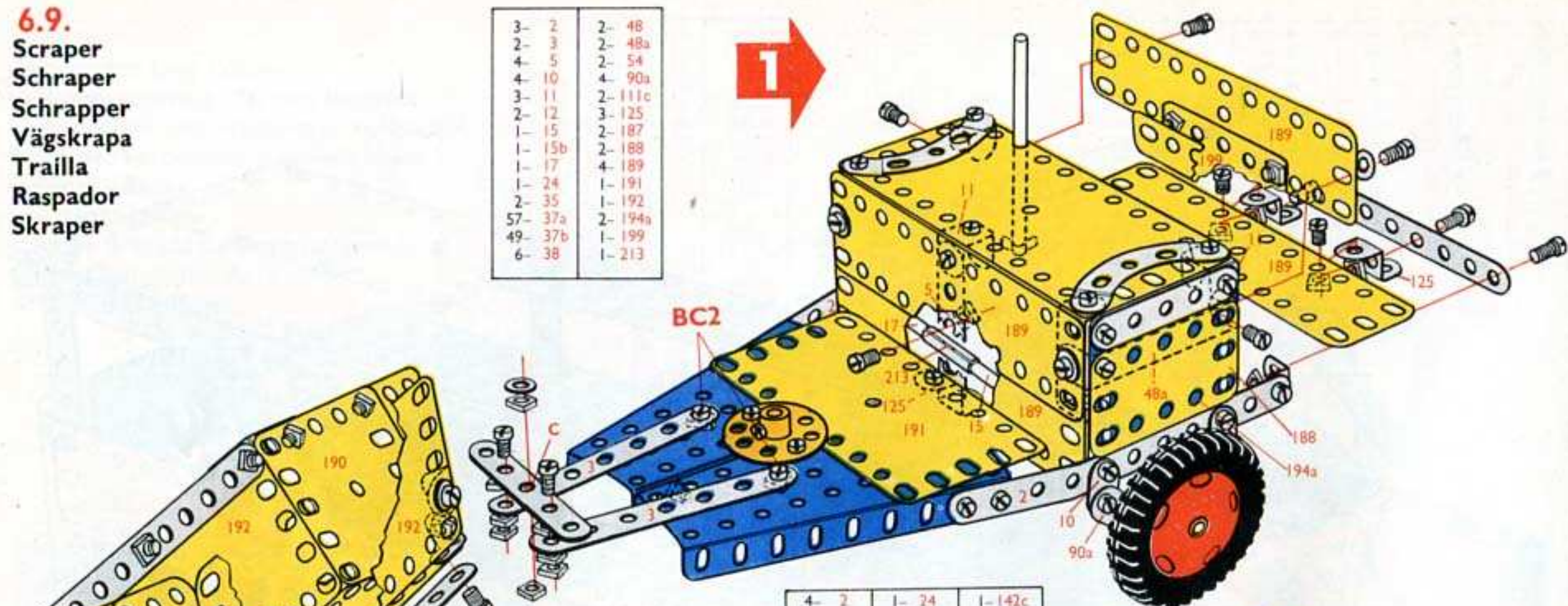

| | | | | | |
|----|-----|-----|------|----|------|
| 4- | 2 | 1- | 24 | 1- | 142c |
| 5- | 5 | 1- | 26 | 1- | 147b |
| 2- | 6a | 1- | 27a | 1- | 155 |
| 1- | 11a | 5- | 35 | 1- | 176 |
| 4- | 12 | 50- | 37a | 2- | 187 |
| 1- | 15 | 50- | 37b | 2- | 188 |
| 1- | 15a | 8- | 38 | 2- | 190 |
| 1- | 16 | 1- | 40 | 1- | 191 |
| 2- | 18a | 5- | 48a | 2- | 193a |
| 1- | 19a | 1- | 52 | 1- | 200 |
| 1- | 20a | 2- | 53a | 2- | 214 |
| 5- | 22 | 1- | 115 | 2- | 221 |
| 1- | 23 | 2- | 126a | 2- | 222 |

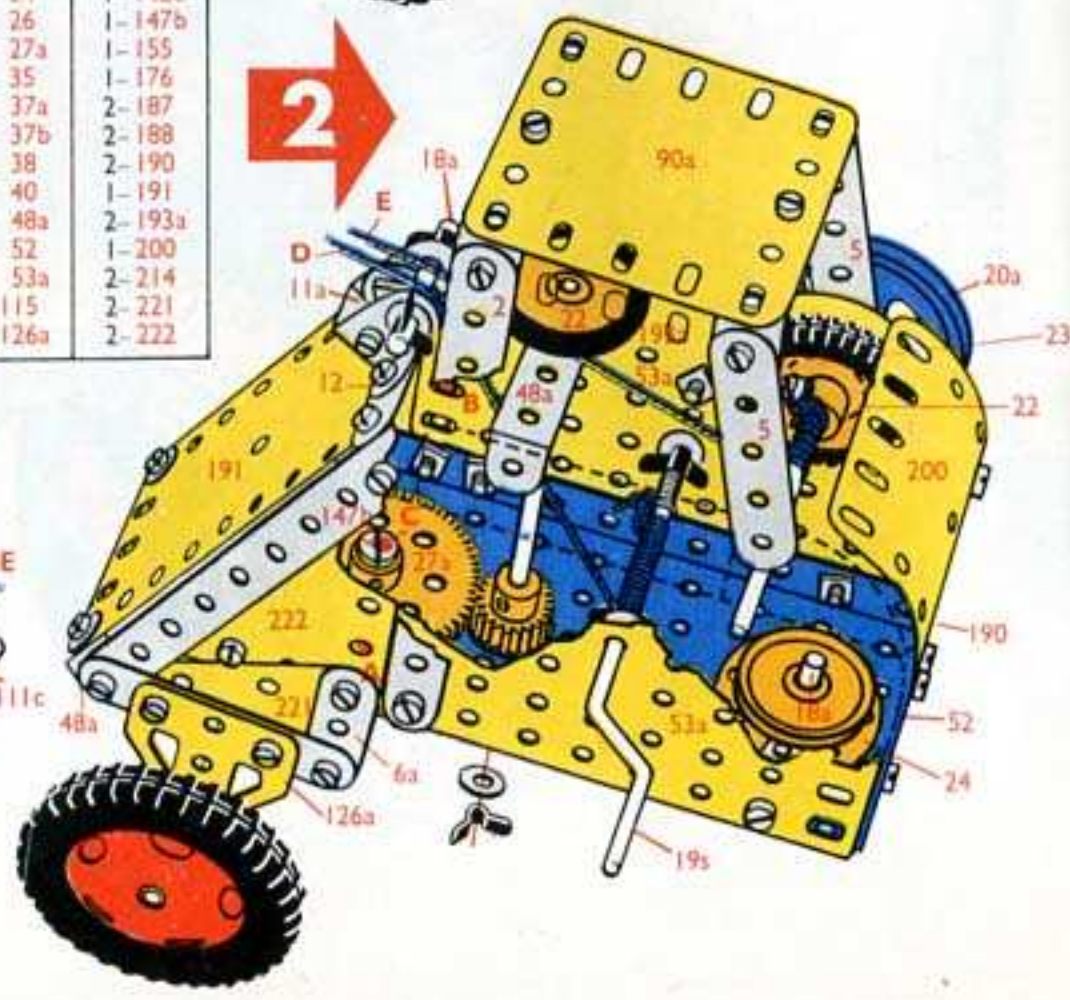

| | | | |
|-----|-----|----|------|
| 7- | 2 | 4- | 38 |
| 3- | 5 | 1- | 48a |
| 1- | 11 | 1- | 51 |
| 6- | 12 | 3- | 111c |
| 2- | 12a | 2- | 126 |
| 1- | 15b | 1- | 186 |
| 2- | 16 | 2- | 190 |
| 8- | 35 | 3- | 192 |
| 39- | 37a | 2- | 221 |
| 31- | 37b | | |

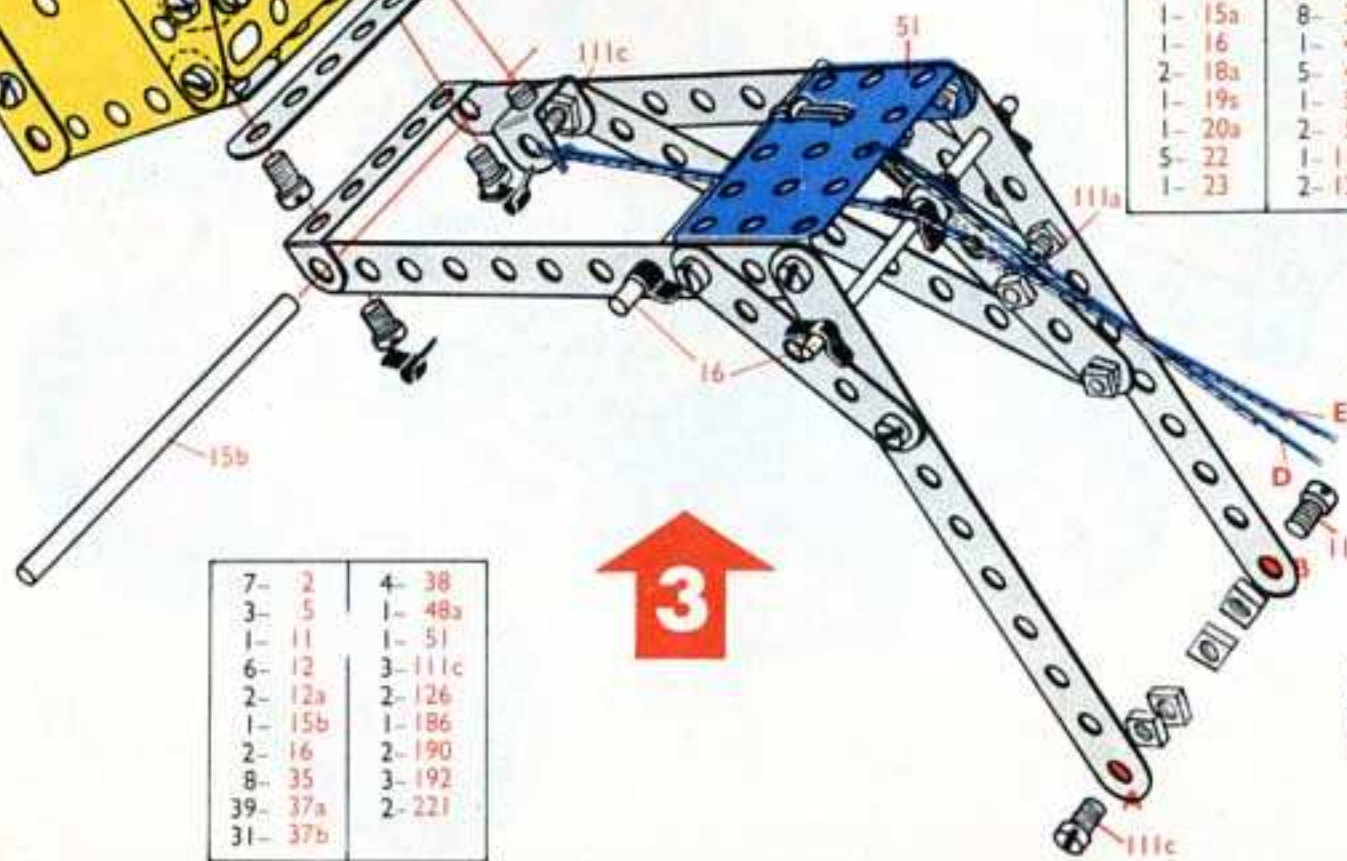

| | | | | | | | |
|-----|-----|------|-----|----|------|----|------|
| 14- | 2- | 1- | 19s | 1- | 52 | 4- | 188 |
| 2- | 3- | 1- | 20a | 2- | 53a | 4- | 189 |
| 12- | 5- | 5- | 22 | 2- | 54 | 4- | 190 |
| 2- | 6a | 1- | 23 | 4- | 90a | 2- | 191 |
| 4- | 10 | 2- | 24 | 5- | 111c | 4- | 192 |
| 4- | 11 | 1- | 26 | 1- | 115 | 2- | 193a |
| 1- | 11a | 1- | 27a | 3- | 125 | 2- | 194a |
| 12- | 12 | 15- | 35 | 2- | 126 | 1- | 199 |
| 2- | 12a | 146- | 37a | 2- | 126a | 1- | 200 |
| 2- | 15 | 130- | 37b | 1- | 142c | 1- | 213 |
| 1- | 15a | 18- | 38 | 1- | 147b | 2- | 214 |
| 2- | 15b | 1- | 40 | 1- | 155 | 4- | 221 |
| 3- | 16 | 2- | 48 | 1- | 176 | 2- | 222 |
| 1- | 17 | 8- | 48a | 1- | 186 | | |
| 2- | 18a | 1- | 51 | 4- | 187 | | |

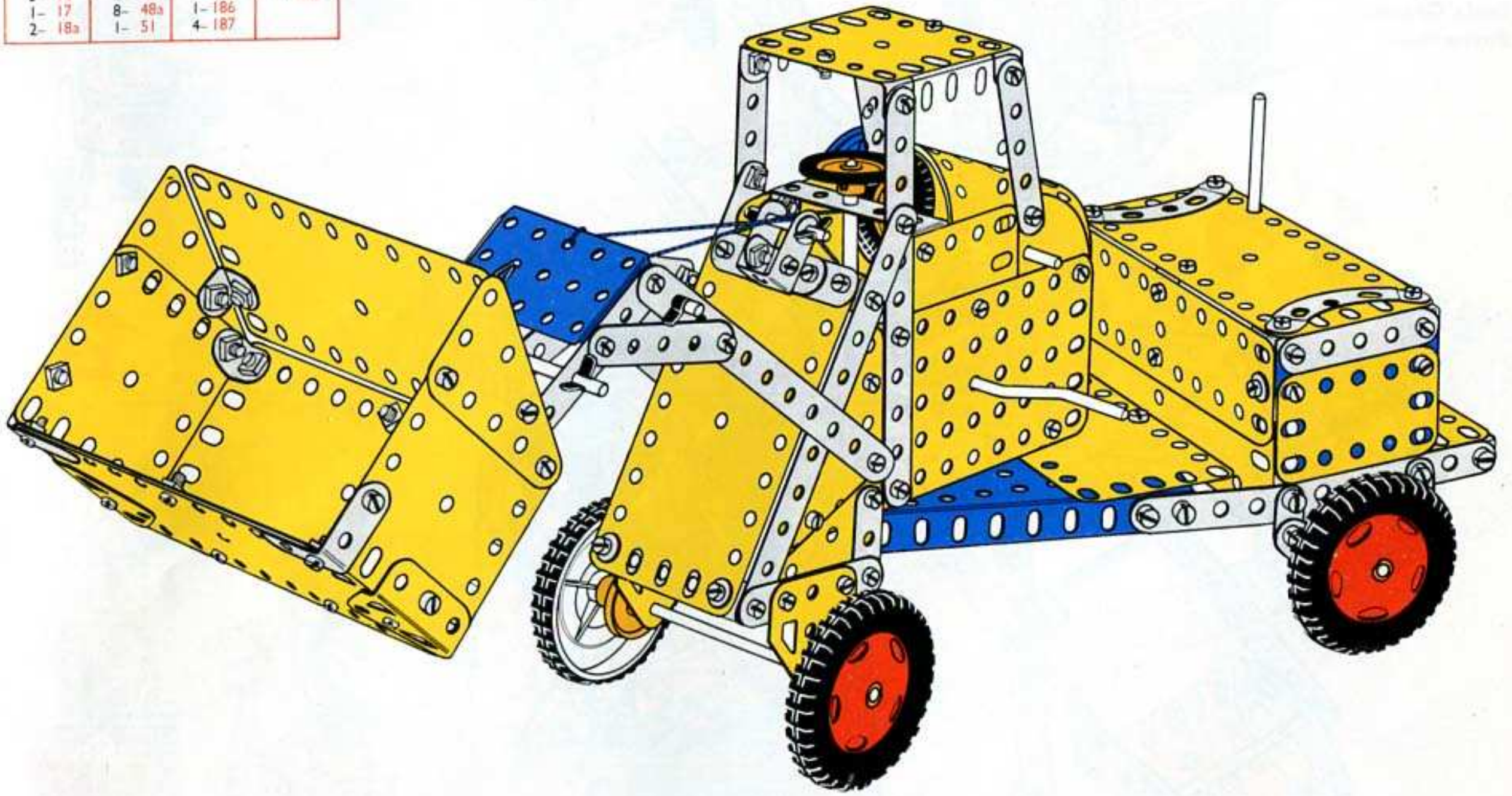

6.10.
Big Wheel
 Groot wiel
 Grande roue
 Ruota gigante
 Riesenrad
 Pariserhjul
 Noria gigante
 Roda Grande
 Pariserhjul

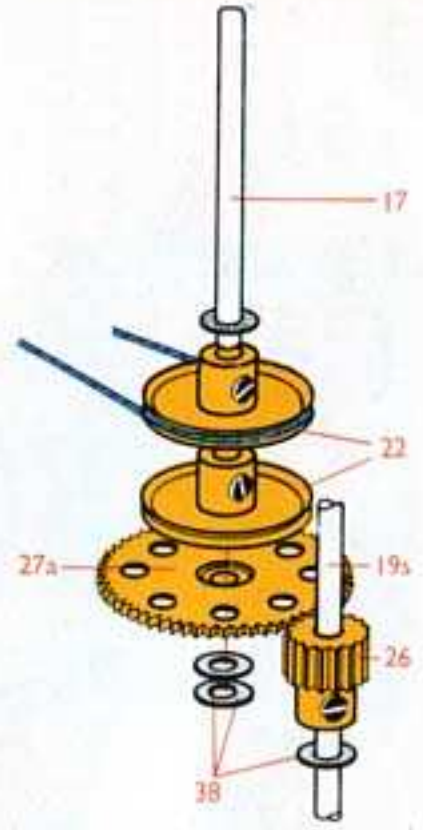
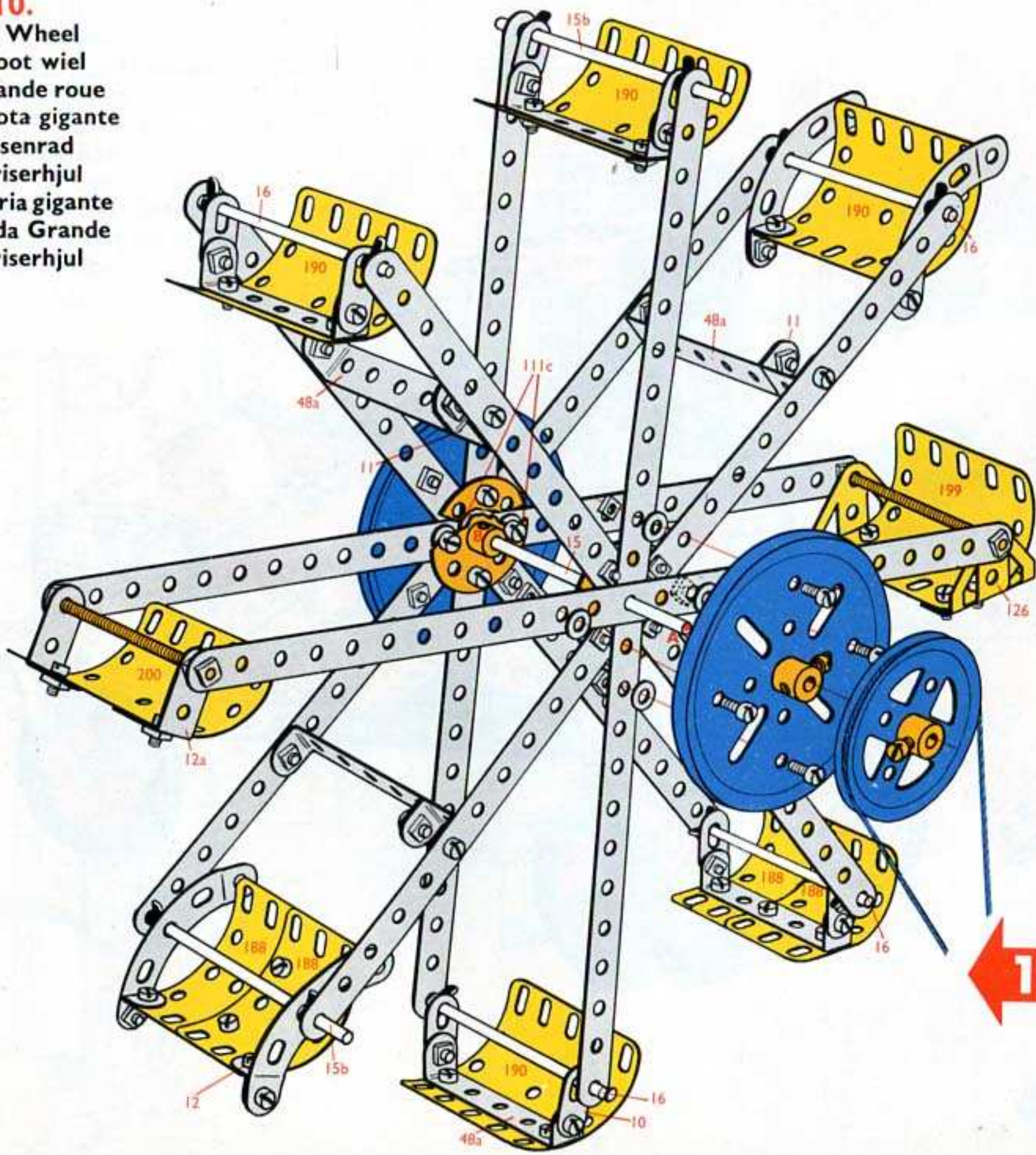

| | | | |
|-----|-----|----|------|
| 2- | 1 | 1- | 40 |
| 14- | 2 | 1- | 45 |
| 12- | 5 | 2- | 48 |
| 2- | 6a | 1- | 51 |
| 4- | 8 | 1- | 52 |
| 1- | 11a | 2- | 53a |
| 8- | 12 | 2- | 99 |
| 1- | 17 | 2- | 111a |
| 2- | 18a | 1- | 115 |
| 1- | 19a | 2- | 125 |
| 3- | 22 | 1- | 176 |
| 1- | 23a | 1- | 186a |
| 1- | 26 | 2- | 192 |
| 1- | 27a | 1- | 213 |
| 4- | 35 | 2- | 214 |
| 73- | 37a | 4- | 221 |
| 71- | 37b | 2- | 222 |
| 5- | 38 | | |



| | | | |
|-----|-----|-----|------|
| 8- | 1 | 70- | 37a |
| 8- | 10 | 58- | 37b |
| 4- | 11 | 8- | 38 |
| 4- | 12 | 8- | 48a |
| 2- | 12a | 2- | 80c |
| 1- | 15 | 4- | 90a |
| 2- | 15b | 4- | 111c |
| 4- | 16 | 2- | 126 |
| 2- | 19b | 4- | 188 |
| 1- | 20a | 4- | 190 |
| 2- | 24 | 1- | 199 |
| 12- | 35 | 1- | 200 |



| | | | |
|--------|----------|--------|--------|
| 10- 1 | 2- 18a | 1- 45 | 1-176 |
| 14- 2 | 2- 19b | 2- 48 | 1-186a |
| 12- 5 | 1- 19a | 8- 48a | 4-188 |
| 2- 6a | 1- 20a | 1- 51 | 4-190 |
| 4- 8 | 3- 22 | 1- 52 | 2-192 |
| 8- 10 | 1- 23a | 2- 53a | 1-199 |
| 4- 11 | 2- 24 | 2- 80c | 1-200 |
| 1- 11a | 1- 26 | 4- 90a | 1-213 |
| 12- 12 | 1- 27a | 2- 99 | 2-214 |
| 2- 12a | 16- 35 | 2-111a | 4-221 |
| 1- 15 | 143- 37a | 4-111c | 2-222 |
| 2- 15b | 129- 37b | 1-115 | *1-M5 |
| 4- 16 | 13- 38 | 2-125 | |
| 1- 17 | 1- 40 | 2-126 | |

*Not included in set No.6

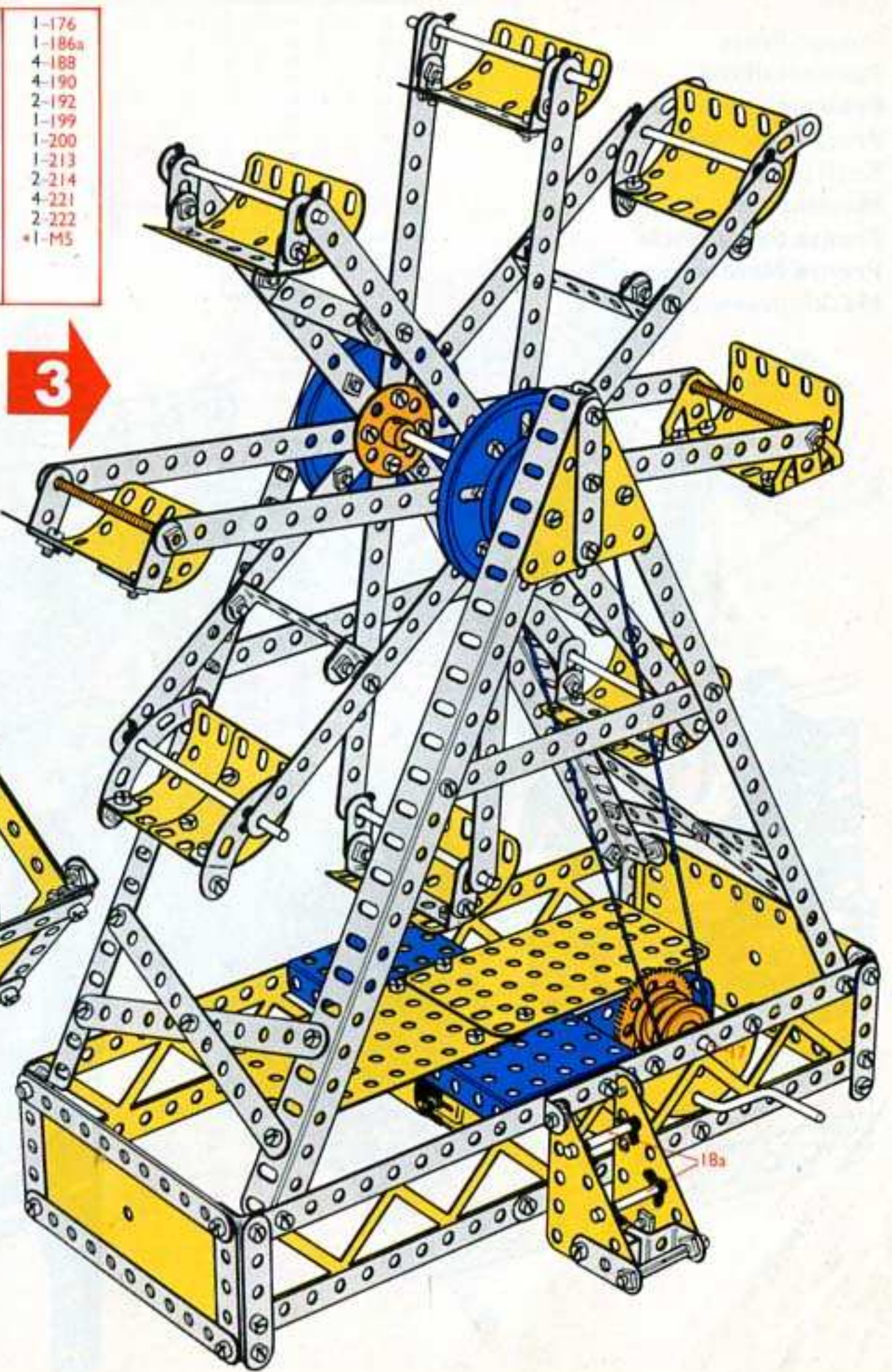
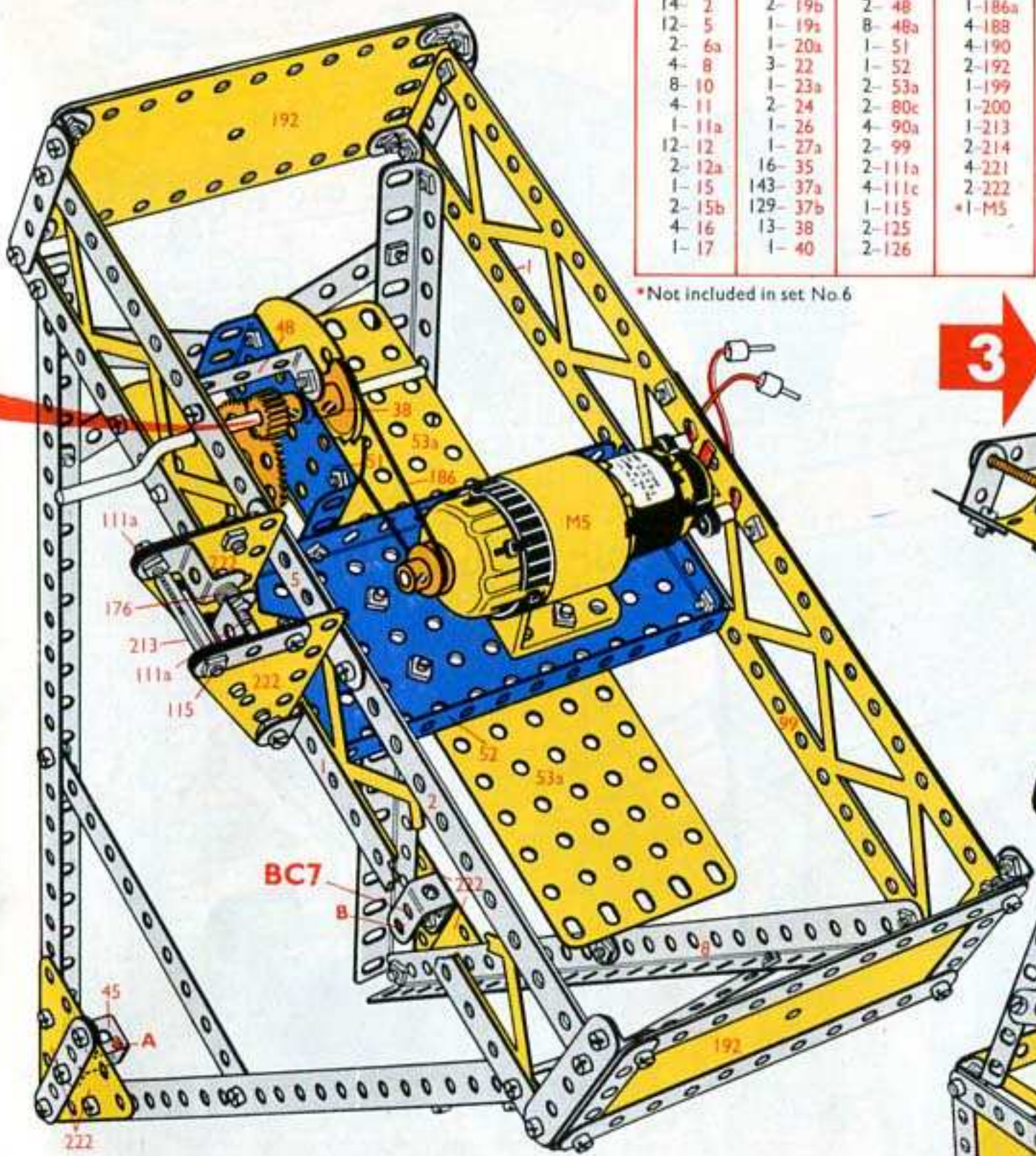

6.11.

Power Press
 Persinstallatie
 Presse mécanique
 Pressa automatica
 Kraftpresse
 Maskinpress
 Prensa de potencia
 Prensa Necânico
 Maskinpresse

| | | | |
|-----|-----|-----|-----|
| 6- | 1 | 79- | 37a |
| 8- | 2 | 75- | 37b |
| 11- | 5 | 8- | 38 |
| 1- | 6a | 1- | 45 |
| 4- | 8 | 6- | 48a |
| 1- | 11a | 1- | 51 |
| 4- | 12 | 1- | 52 |
| 2- | 12a | 1- | 80c |
| 2- | 16 | 2- | 126 |
| 2- | 17 | 2- | 189 |
| 1- | 19b | 2- | 191 |
| 1- | 20a | 1- | 192 |
| 1- | 24c | 2- | 214 |
| 10- | 35 | | |

| | | | |
|----|-----|-----|------|
| 6- | 2 | 6- | 35 |
| 1- | 10 | 37- | 37a |
| 4- | 12 | 37- | 37b |
| 2- | 15 | 11- | 38 |
| 2- | 16 | 1- | 40 |
| 1- | 18a | 2- | 48a |
| 1- | 19a | 2- | 53a |
| 5- | 22 | 2- | 54 |
| 1- | 23a | 2- | 90a |
| 2- | 24 | 2- | 142c |
| 1- | 24c | 1- | 186a |
| 1- | 26 | 1- | 189 |
| 1- | 27a | 1- | 213 |

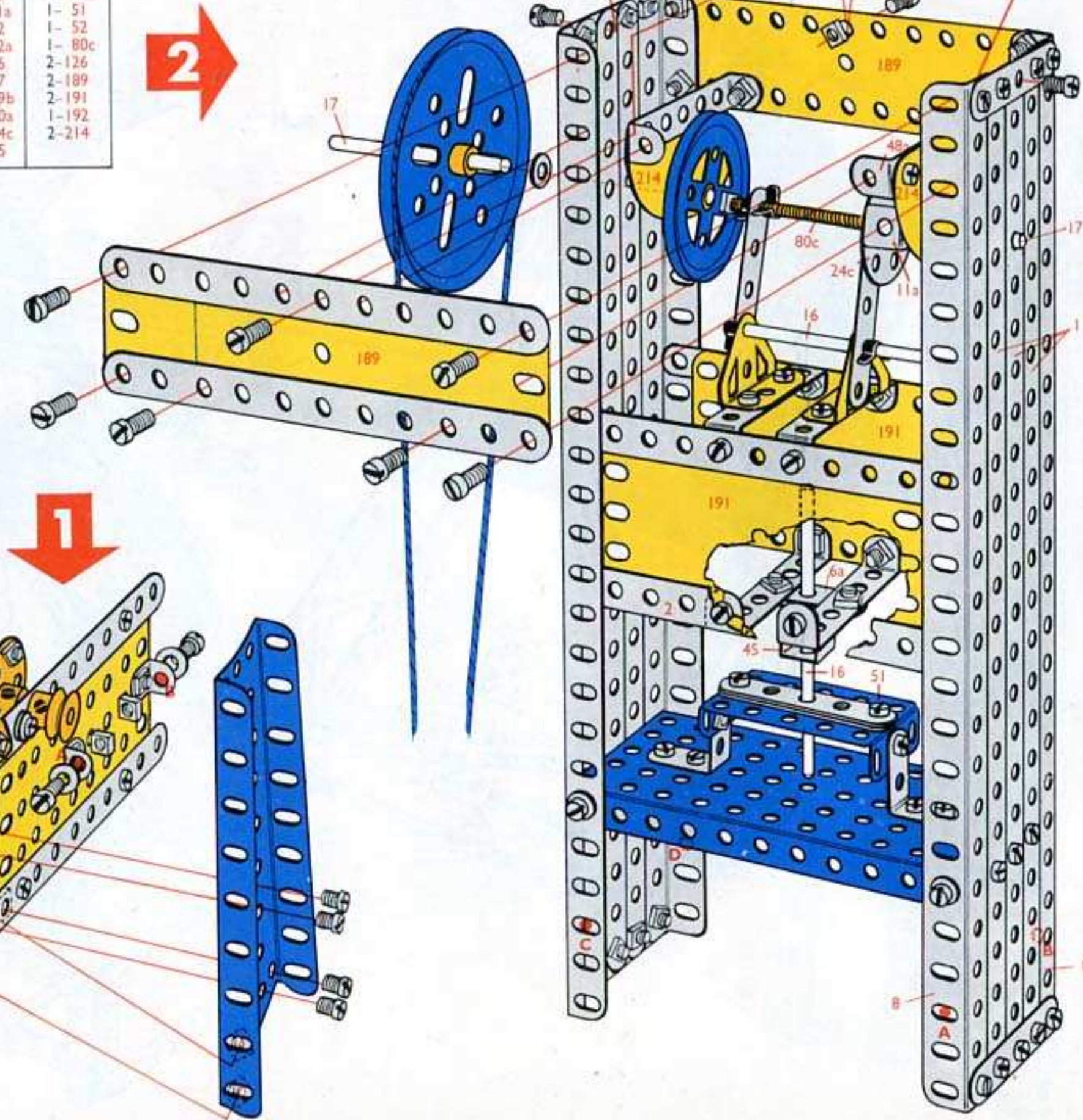
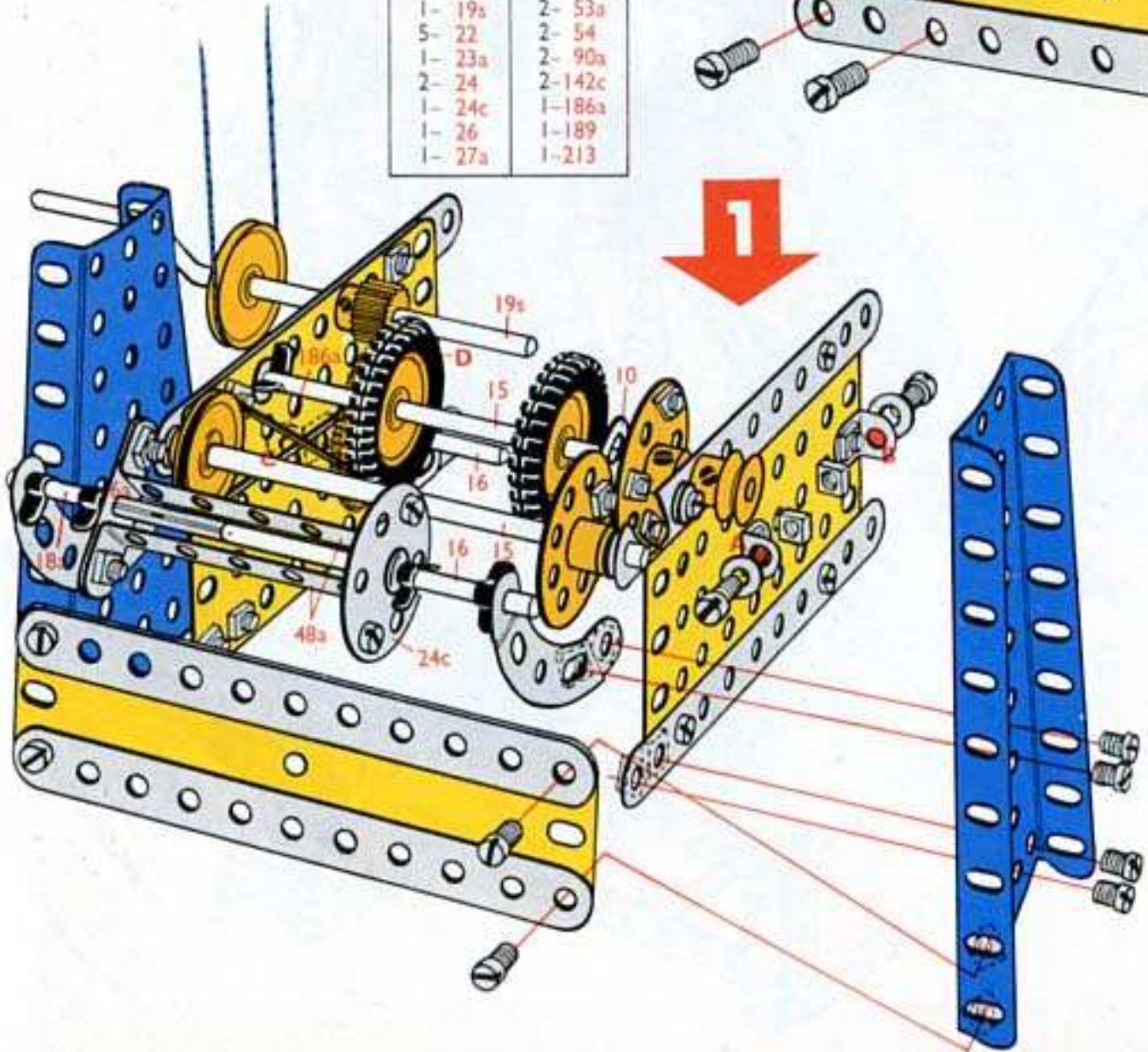

| | | | |
|--------|--------|----------|---------|
| 6- 1 | 2- 17 | 16- 35 | 1- 80c |
| 14- 2 | 1- 18a | 116- 37a | 2- 90a |
| 11- 5 | 1- 19b | 112- 37b | 2- 126 |
| 1- 6a | 1- 19c | 19- 38 | 2- 142c |
| 4- 8 | 1- 20a | 1- 40 | 1- 186a |
| 1- 10 | 5- 22 | 1- 45 | 3- 189 |
| 1- 11a | 1- 23a | 8- 48a | 2- 191 |
| 8- 12 | 2- 24 | 1- 51 | 1- 192 |
| 2- 12a | 2- 24c | 1- 52 | 1- 213 |
| 2- 15 | 1- 26 | 2- 53a | 2- 214 |
| 4- 16 | 1- 27a | 2- 54 | |

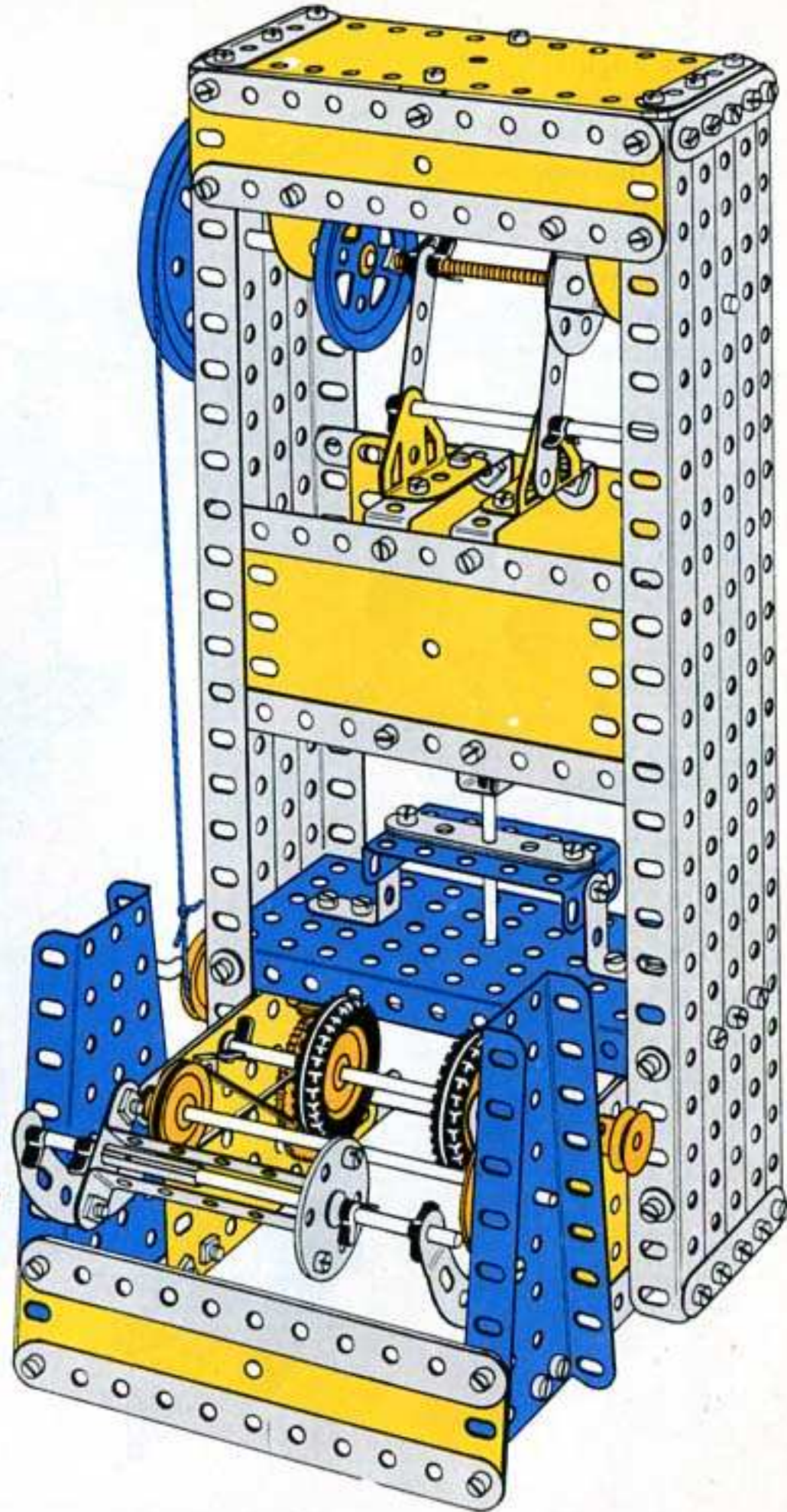
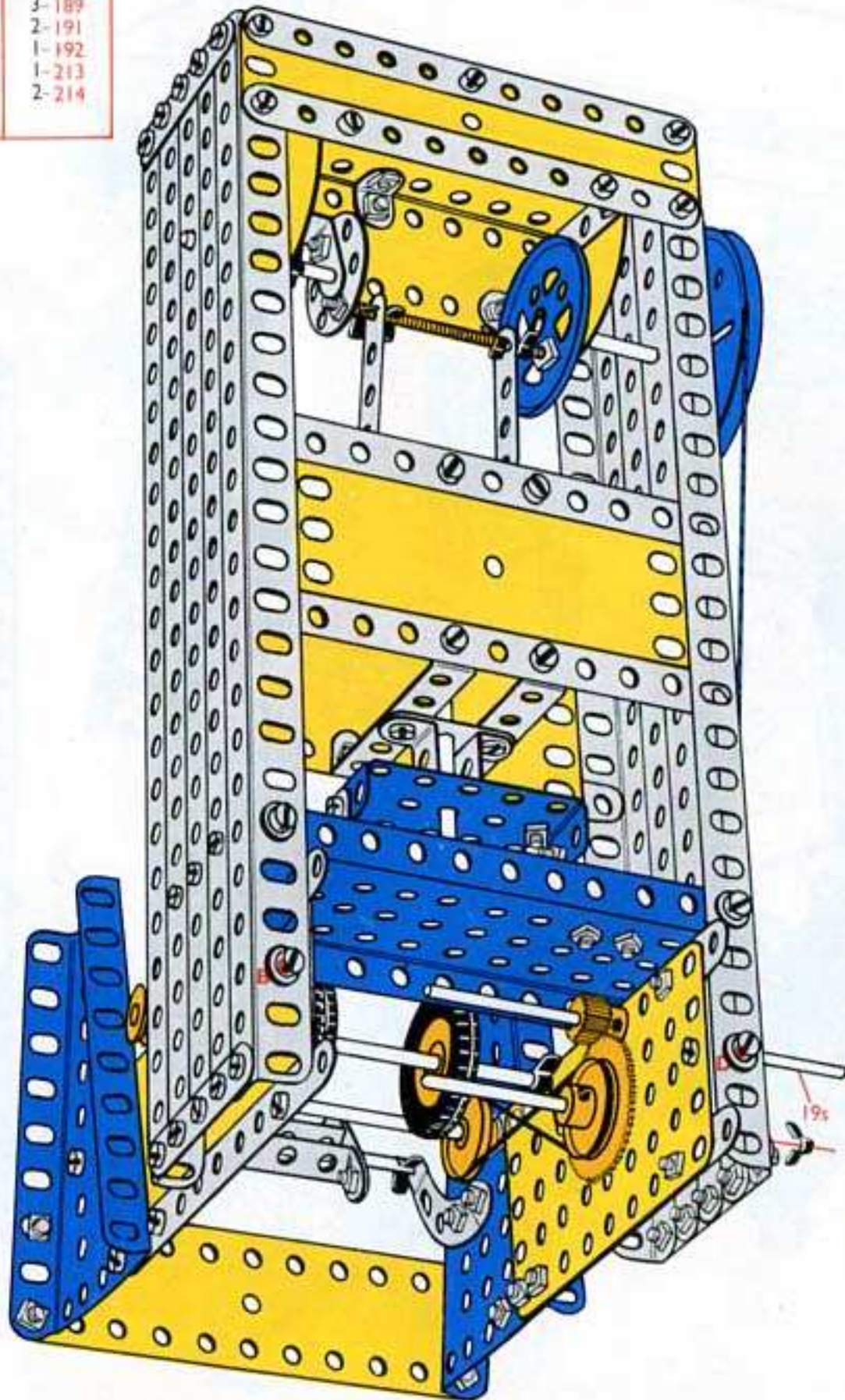

6.12.

Marine Engine
Scheepsmotor
Moteur de bateau
Motore marino
Schiffsmotor
Fartygsmotor
Motor marino
Motor Marítimo
Skipsmotor

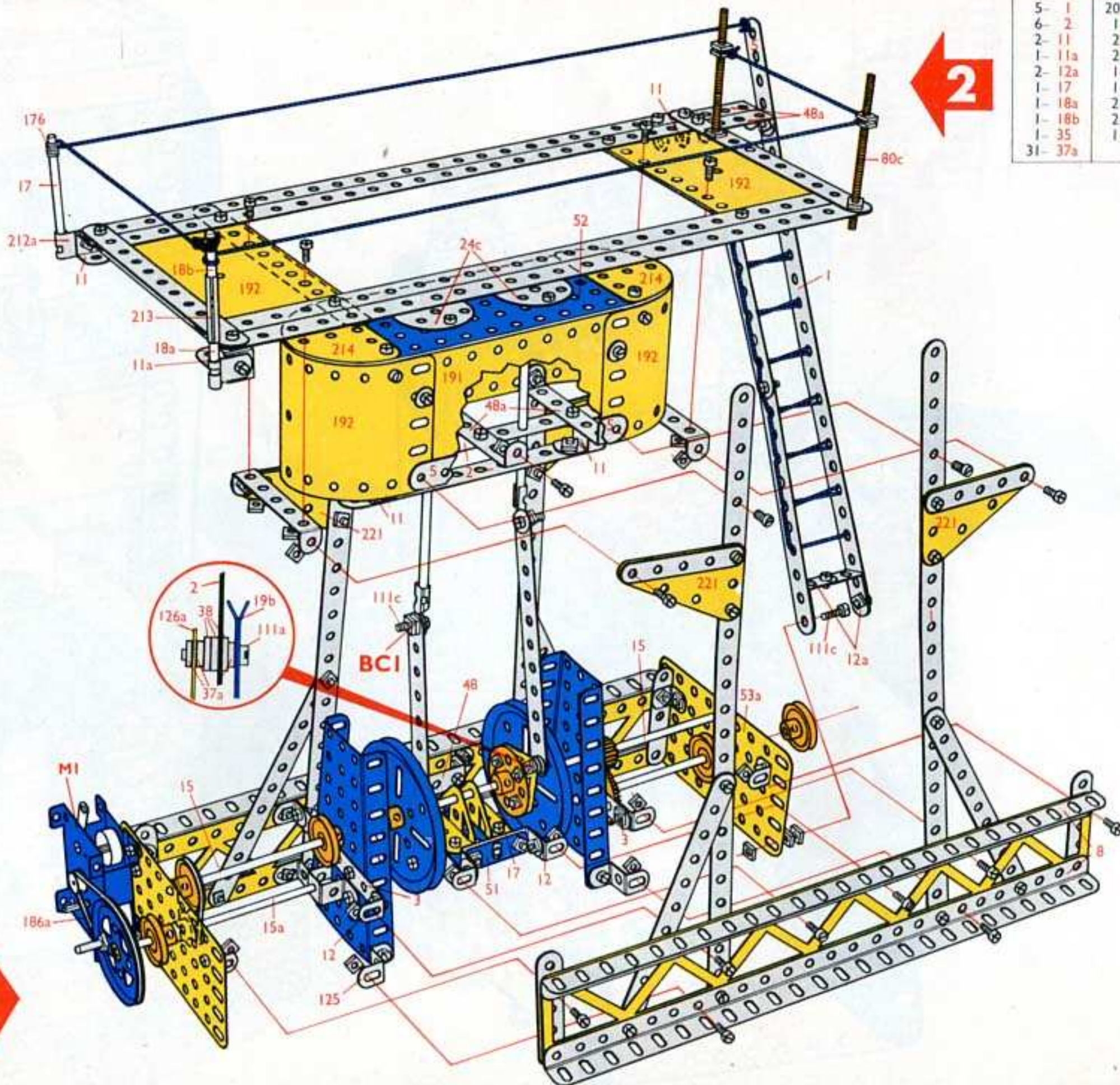

| | |
|---------|---------|
| 5- 1 | 20- 37b |
| 6- 2 | 1- 40 |
| 2- 11 | 2- 48a |
| 1- 11a | 2- 80c |
| 2- 12a | 1- 111c |
| 1- 17 | 1- 176 |
| 1- 18a | 2- 192 |
| 1- 18b | 2- 212a |
| 1- 35 | 1- 213 |
| 31- 37a | |

| | |
|----------|---------|
| 4- 1 | 1- 45 |
| 8- 2 | 2- 48 |
| 2- 3 | 5- 48a |
| 12- 5 | 1- 51 |
| 4- 8 | 1- 52 |
| 2- 11 | 2- 53a |
| 12- 12 | 2- 54 |
| 2- 15 | 2- 99 |
| 1- 15a | 2- 111a |
| 1- 15b | 2- 111c |
| 2- 16 | 1- 115 |
| 1- 17 | 4- 125 |
| 2- 19b | 2- 126 |
| 1- 20a | 2- 126a |
| 5- 22 | 1- 186 |
| 1- 23a | 1- 186a |
| 2- 24 | 2- 191 |
| 2- 24c | 2- 192 |
| 1- 26 | 2- 212 |
| 1- 27a | 2- 214 |
| 111- 37a | 4- 221 |
| 101- 37b | |
| 13- 38 | |

| | | | |
|--------|----------|--------|--------|
| 9- 1 | 1- 18a | 1- 40 | 2-126 |
| 14- 2 | 1- 18b | 1- 45 | 2-126a |
| 2- 3 | 2- 19b | 2- 48 | 1-176 |
| 12- 5 | 1- 20a | 7- 48a | 1-186 |
| 4- 8 | 5- 22 | 1- 51 | 1-186a |
| 4- 11 | 1- 23a | 1- 52 | 2-191 |
| 1- 11a | 2- 24 | 2- 53a | 4-192 |
| 12- 12 | 2- 24c | 2- 54 | 2-212 |
| 2- 12a | 1- 26 | 2- 80c | 2-212a |
| 2- 15 | 1- 27a | 2- 99 | 1-213 |
| 1- 15a | 1- 35 | 2-111a | 2-214 |
| 1- 15b | 142- 37a | 3-111c | 4-221 |
| 2- 16 | 121- 37b | 1-115 | *1-M1 |
| 2- 17 | 13- 38 | 4-125 | |

*Not included in set

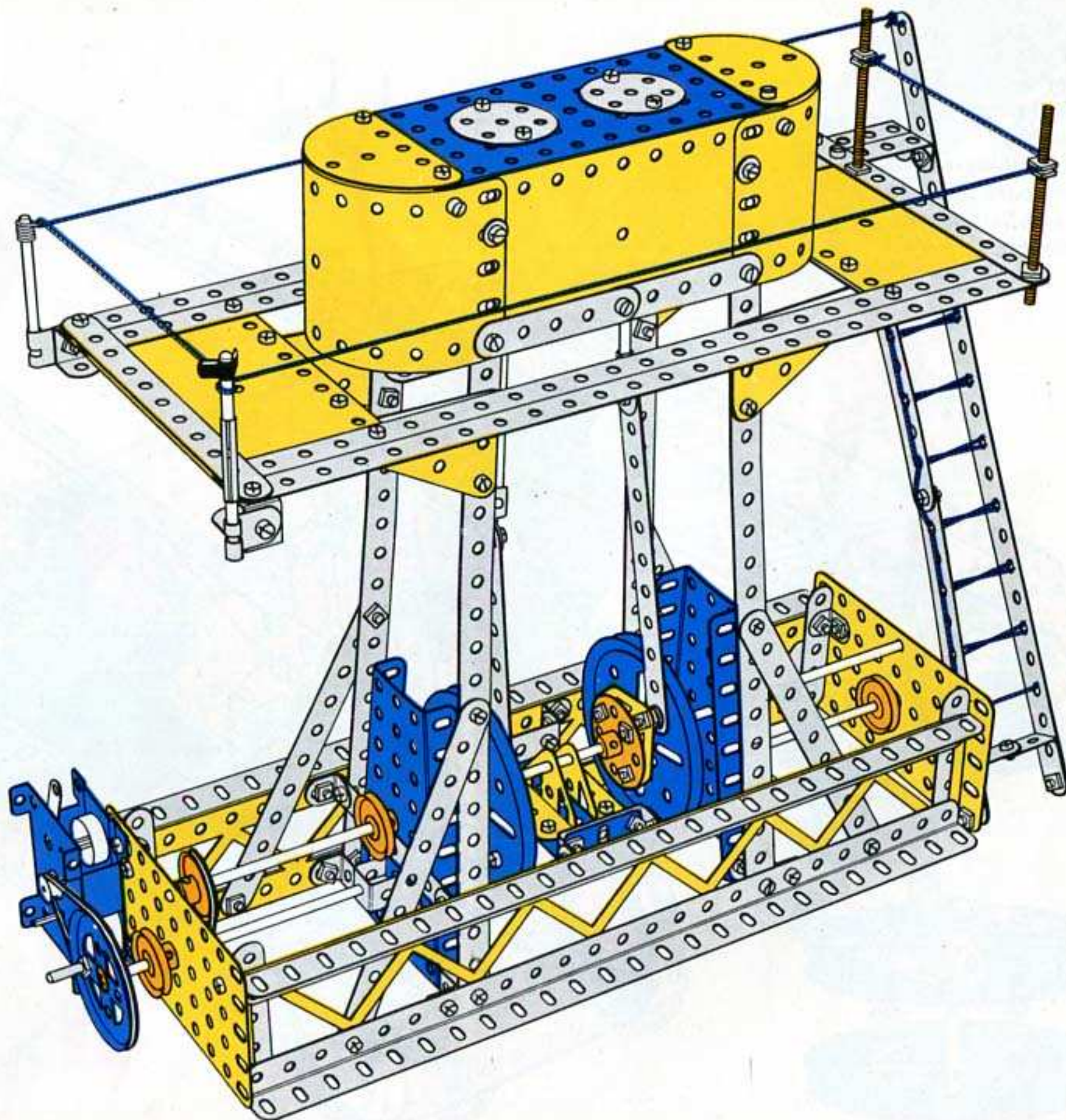

6.13.
Fire Escape
Brandladder
Escalier de secours
Uscita di sicurezza
Notausgang
Brandräddningsredskap
Escalera para incendio
Escada de Salvamento
Branntrapp

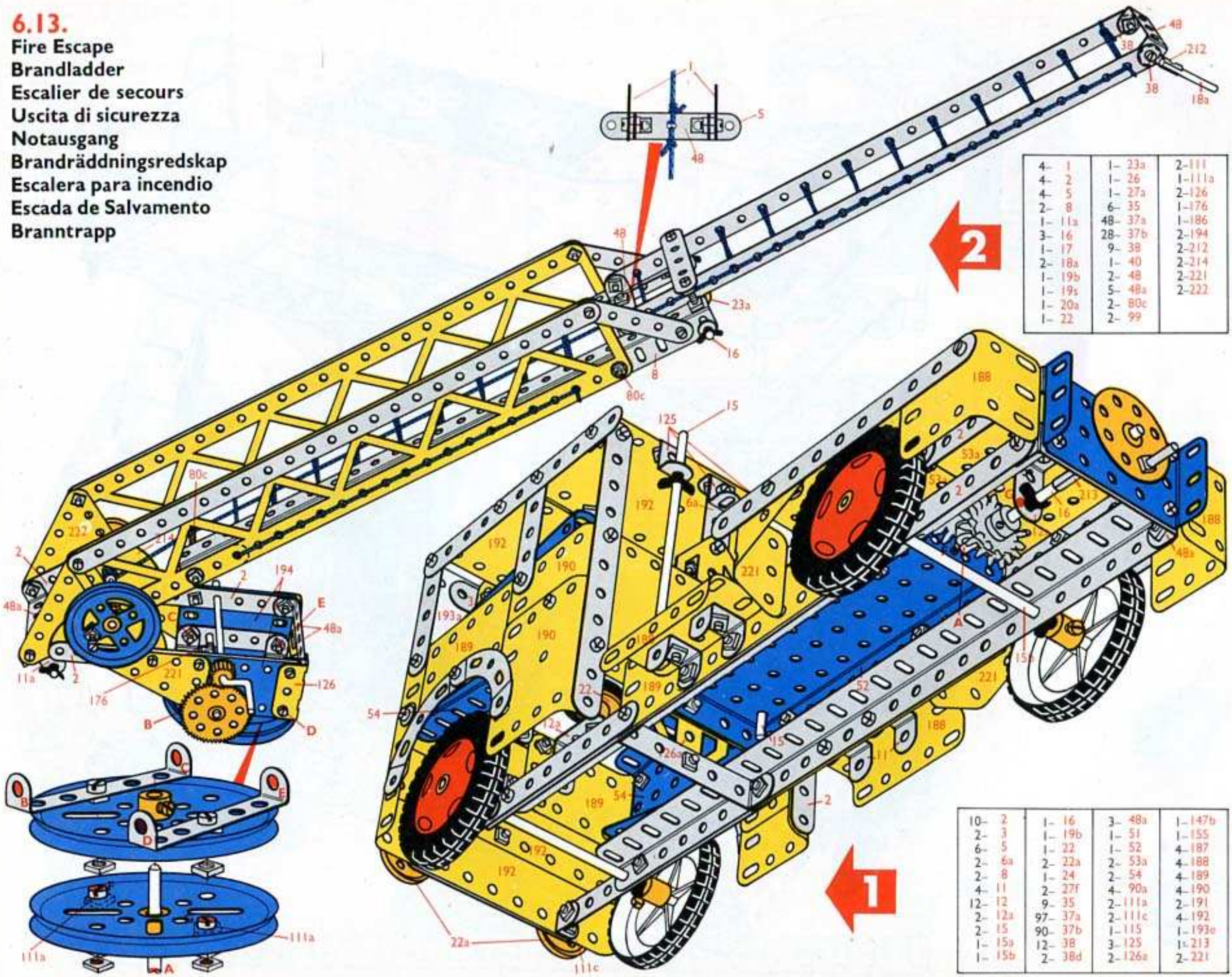

| | | | | | |
|----|-----|-----|-----|----|------|
| 4- | 1 | 1- | 23a | 2- | 111 |
| 4- | 2 | 1- | 26 | 1- | 111a |
| 4- | 5 | 1- | 27a | 2- | 126 |
| 2- | 8 | 6- | 35 | 1- | 176 |
| 1- | 11a | 48- | 37a | 1- | 186 |
| 3- | 16 | 28- | 37b | 2- | 194 |
| 1- | 17 | 9- | 38 | 2- | 212 |
| 2- | 18a | 1- | 40 | 2- | 214 |
| 1- | 19b | 2- | 48 | 2- | 221 |
| 1- | 19c | 5- | 48a | 2- | 222 |
| 1- | 20a | 2- | 80c | | |
| 1- | 22 | 2- | 99 | | |

| | | | | | | | |
|-----|-----|-----|-----|----|------|----|------|
| 10- | 2 | 1- | 16 | 3- | 48a | 1- | 147b |
| 2- | 3 | 1- | 19b | 1- | 51 | 1- | 155 |
| 6- | 5 | 1- | 22 | 1- | 52 | 4- | 187 |
| 2- | 6a | 2- | 22a | 2- | 53a | 4- | 188 |
| 2- | 8 | 1- | 24 | 2- | 54 | 4- | 189 |
| 4- | 11 | 2- | 27f | 4- | 90a | 4- | 190 |
| 12- | 12 | 9- | 35 | 2- | 111a | 2- | 191 |
| 2- | 12a | 97- | 37a | 2- | 111c | 4- | 192 |
| 2- | 15 | 90- | 37b | 1- | 115 | 1- | 193e |
| 1- | 15a | 12- | 38 | 3- | 125 | 1- | 213 |
| 1- | 15b | 2- | 38d | 2- | 126a | 2- | 221 |

| | | | |
|--------|----------|---------|---------|
| 4- 1 | 2- 19b | 2- 48 | 1- 147b |
| 14- 2 | 1- 19a | 8- 48a | 1- 155 |
| 2- 3 | 1- 20a | 1- 51 | 1- 176 |
| 10- 5 | 2- 22 | 1- 52 | 4- 187 |
| 2- 6a | 2- 22a | 2- 53a | 4- 188 |
| 4- 8 | 1- 23a | 2- 54 | 4- 189 |
| 4- 11 | 1- 24 | 2- 80c | 4- 190 |
| 1- 11a | 1- 26 | 4- 90a | 2- 191 |
| 12- 12 | 1- 27a | 2- 99 | 4- 192 |
| 2- 12a | 2- 27f | 2- 111 | 1- 193e |
| 2- 15 | 15- 35 | 3- 111a | 2- 194 |
| 1- 15a | 145- 37a | 2- 111c | 2- 212 |
| 1- 15b | 118- 37b | 1- 115 | 1- 213 |
| 4- 16 | 21- 38 | 3- 125 | 2- 214 |
| 1- 17 | 2- 38d | 2- 126 | 4- 221 |
| 2- 18a | 1- 40 | 2- 126a | 2- 222 |

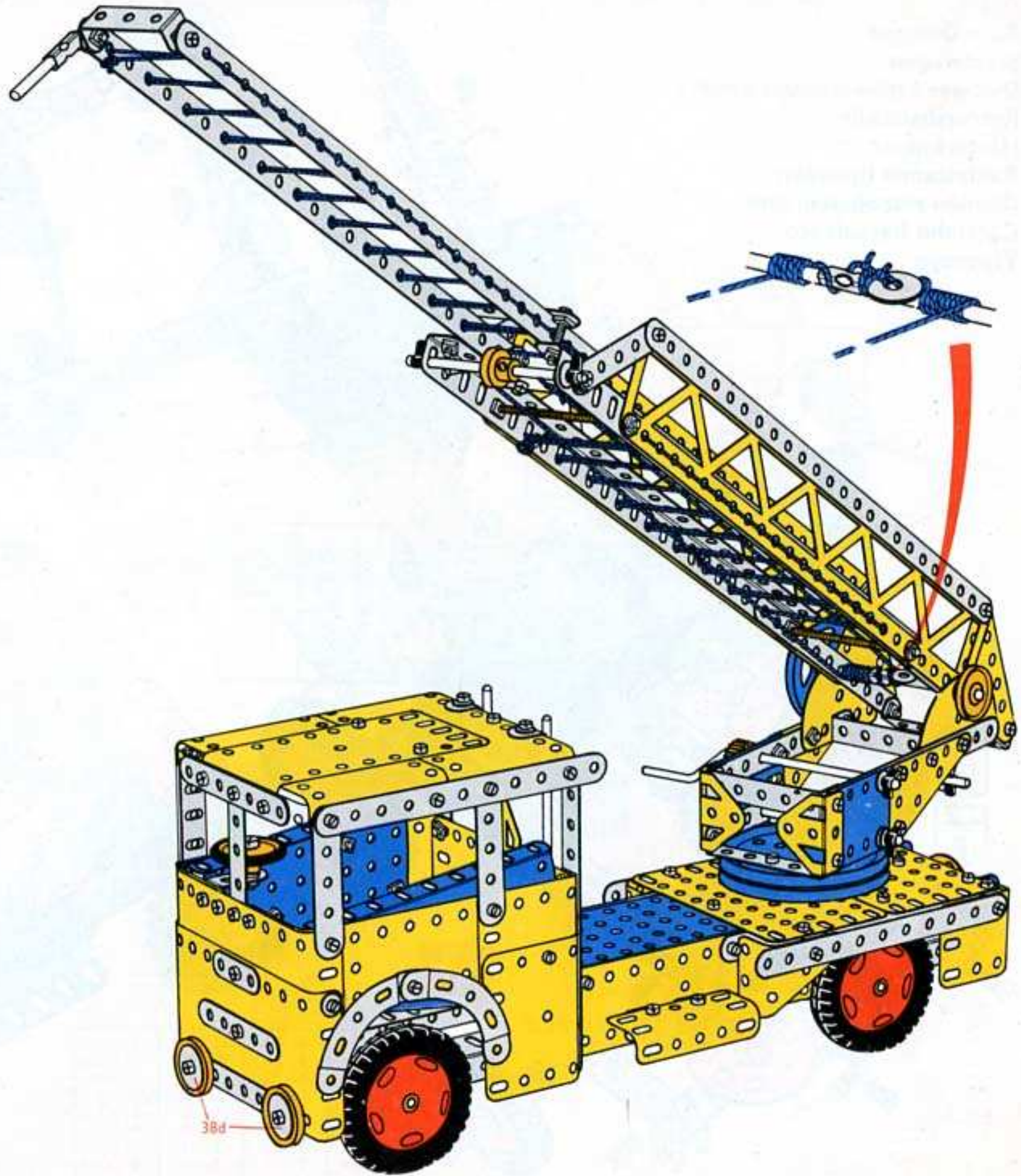

38d

6.14.
Rear Dumper
Stertwagen
Dumper à déversement arrière
Retroribaltabile
Hinterkipper
Baklastande tippvagn
Camión retrobasculante
Carrinho Basculante
Tippvogn

| | | | |
|--------|--------|---------|---------|
| 7- 2 | 1- 16 | 58- 37a | 1- 126 |
| 2- 3 | 1- 18b | 58- 37b | 2- 126a |
| 2- 5 | 1- 19s | 8- 38 | 1- 147b |
| 2- 10 | 2- 22 | 1- 45 | 2- 187 |
| 1- 11 | 1- 24 | 2- 48 | 2- 214 |
| 1- 11a | 2- 24c | 2- 48a | 1- 215 |
| 8- 12 | 1- 26 | 1- 51 | |
| 2- 12a | 1- 27a | 3- 90a | |
| 1- 15 | 5- 35 | 2- 125 | |

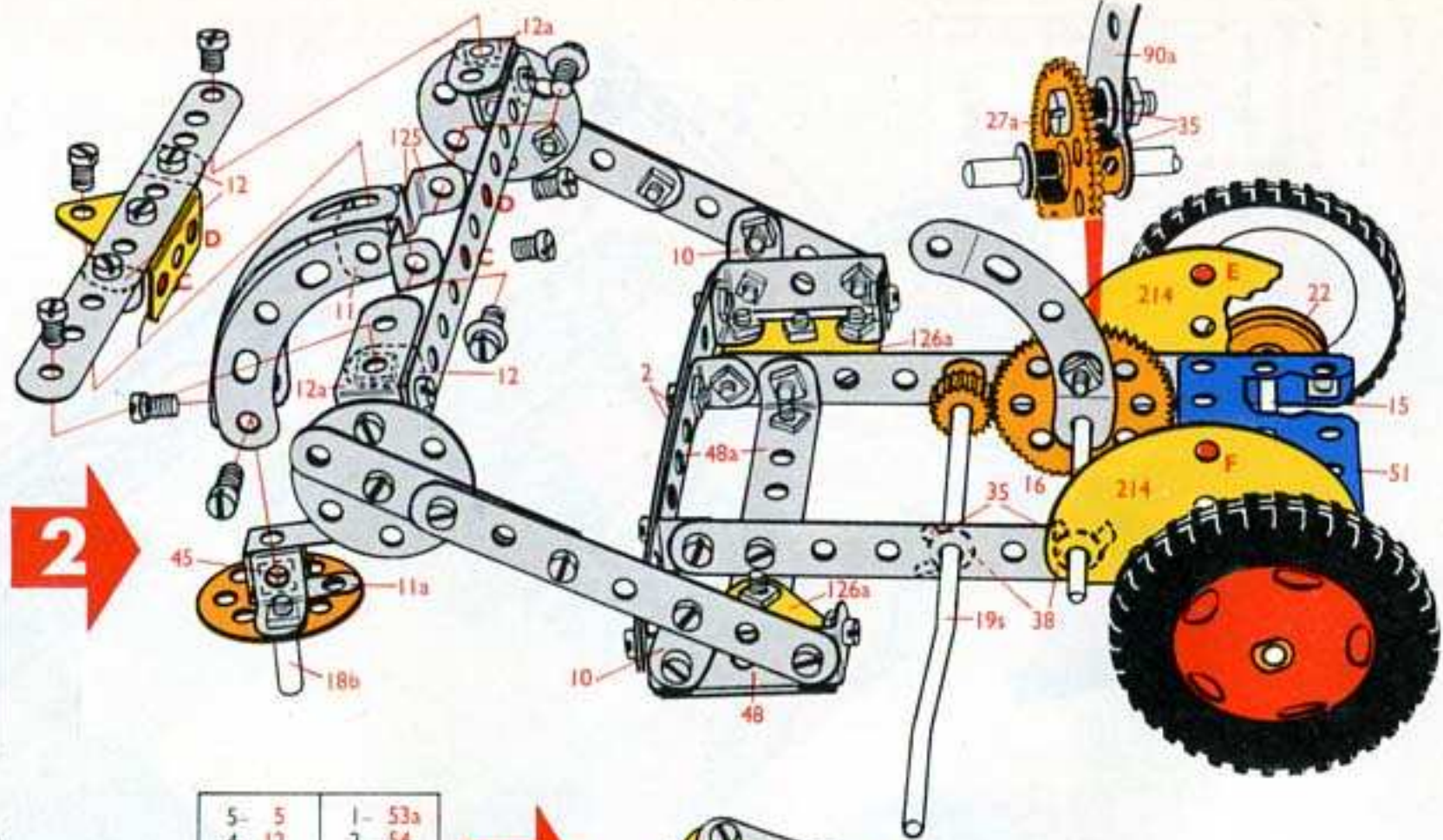

| | |
|---------|--------|
| 5- 5 | 1- 53a |
| 4- 12 | 2- 54 |
| 8- 12c | 2- 125 |
| 1- 16 | 4- 188 |
| 47- 37a | 2- 190 |
| 47- 37b | 2- 191 |
| 4- 38 | 4- 221 |
| 1- 48a | 2- 222 |

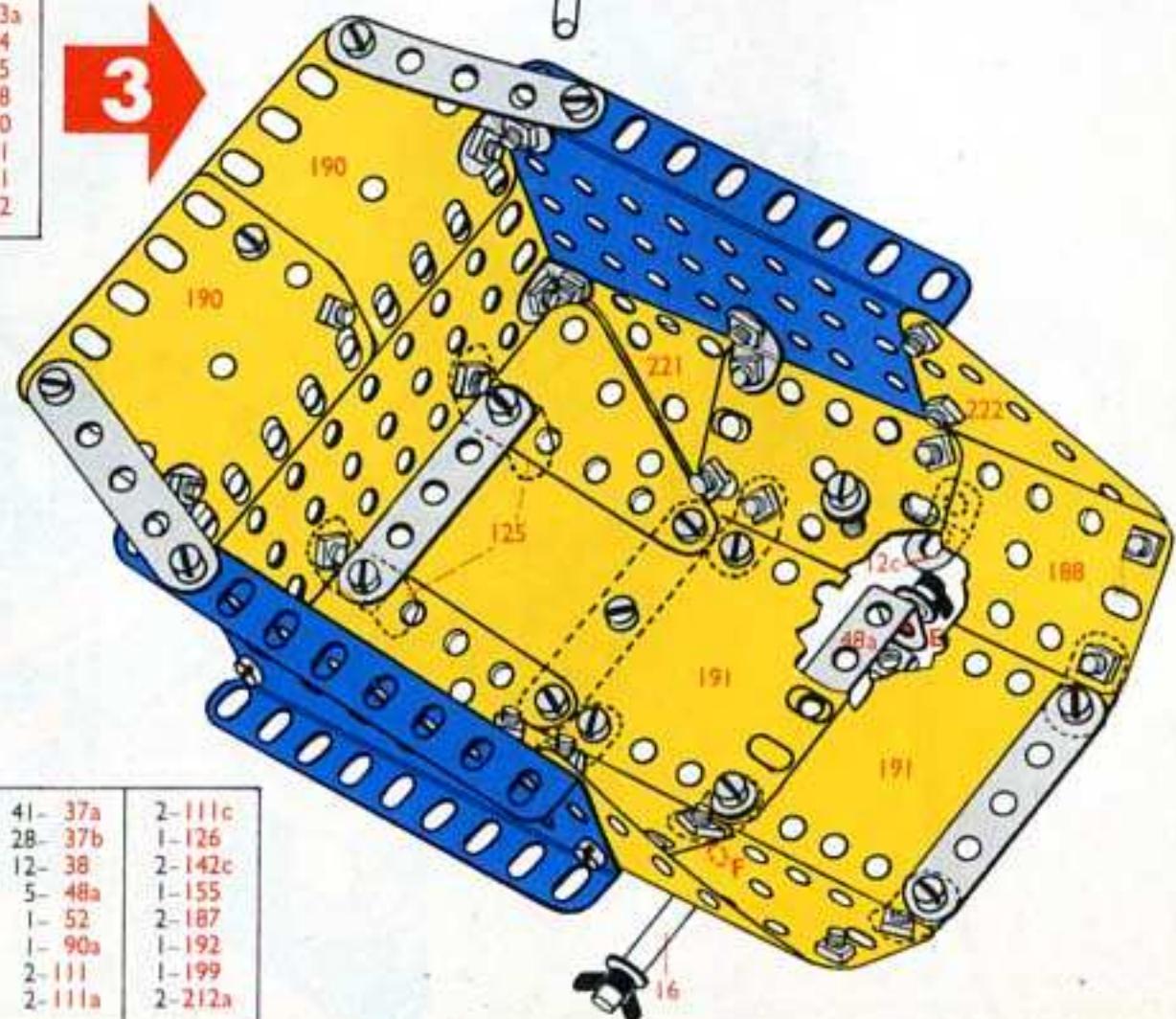

| | | | |
|--------|--------|---------|---------|
| 5- 5 | 1- 20a | 41- 37a | 2- 111c |
| 2- 6a | 3- 22 | 28- 37b | 1- 126 |
| 1- 10 | 2- 22a | 12- 38 | 2- 142c |
| 2- 11 | 1- 23 | 5- 48a | 1- 155 |
| 1- 15a | 1- 23a | 1- 52 | 2- 187 |
| 1- 15b | 1- 24 | 1- 90a | 1- 192 |
| 1- 16 | 2- 27f | 2- 111 | 1- 199 |
| 1- 18a | 2- 35 | 2- 111a | 2- 212a |

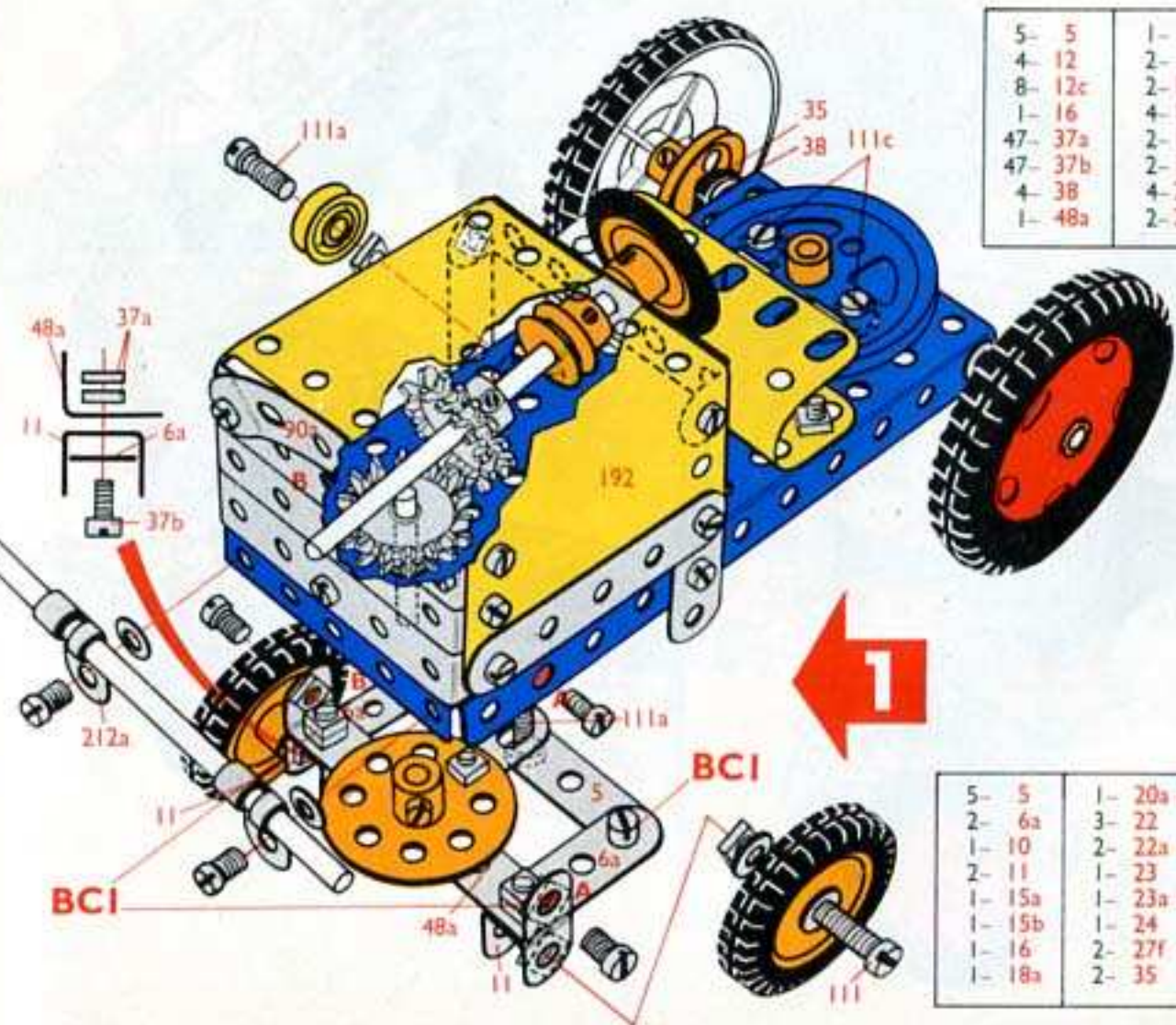

| | | | |
|--------|----------|---------|---------|
| 7- 2 | 1- 18b | 24- 38 | 2- 142c |
| 2- 3 | 1- 19c | 1- 45 | 1- 147b |
| 12- 5 | 1- 20a | 2- 48 | 1- 155 |
| 2- 6a | 5- 22 | 8- 48a | 4- 187 |
| 3- 10 | 2- 22a | 1- 51 | 4- 188 |
| 3- 11 | 1- 23 | 1- 52 | 2- 190 |
| 1- 11a | 1- 23a | 1- 53a | 2- 191 |
| 12- 12 | 2- 24 | 2- 54 | 1- 192 |
| 2- 12a | 2- 24c | 4- 90a | 1- 199 |
| 8- 12c | 1- 26 | 2- 111 | 2- 212a |
| 1- 15 | 1- 27a | 2- 111a | 2- 214 |
| 1- 15a | 2- 27f | 2- 111c | 1- 215 |
| 1- 15b | 7- 35 | 4- 125 | 4- 221 |
| 3- 16 | 146- 37a | 2- 126 | 2- 222 |
| 1- 18a | 133- 37b | 2- 126a | |

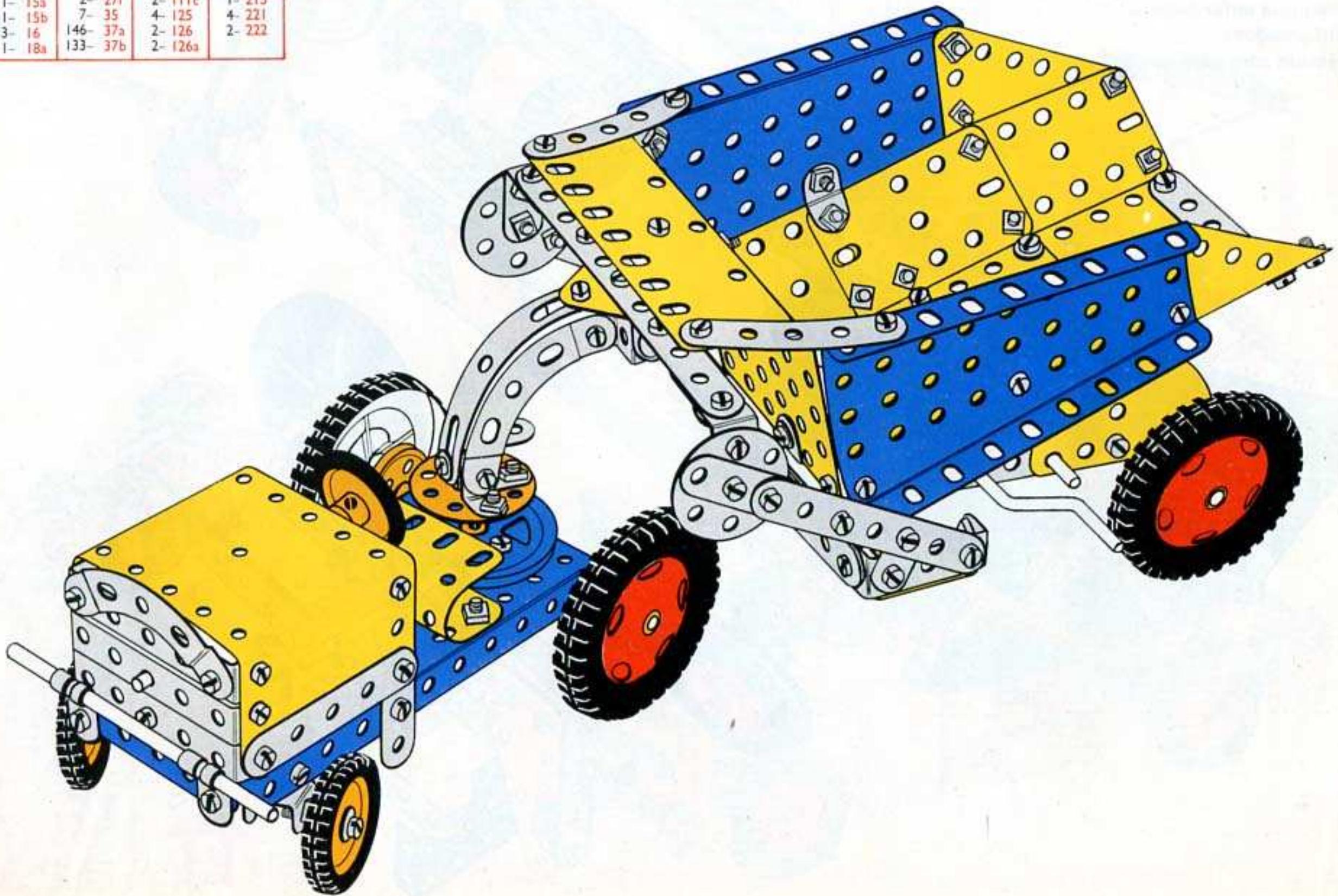

6.15.

Baling Machine
Balenpers
Presse à balles
Imballatrice
Emballiermaschine
Balpress
Máquina enfardadora
Enfardadora
Maskin som pakker i baller

| | | | |
|-----|-----|----|------|
| 2- | 1 | 1- | 52 |
| 4- | 2 | 2- | 53a |
| 8- | 5 | 1- | 54 |
| 2- | 6a | 2- | 80c |
| 4- | 8 | 2- | 90a |
| 4- | 12 | 2- | 111c |
| 1- | 12a | 2- | 125 |
| 2- | 15 | 2- | 126 |
| 1- | 27f | 2- | 126a |
| 4- | 35 | 4- | 187 |
| 80- | 37a | 2- | 188 |
| 70- | 37b | 4- | 190 |
| 12- | 38 | 1- | 200 |
| 1- | 48 | 2- | 214 |
| 6- | 48a | | |

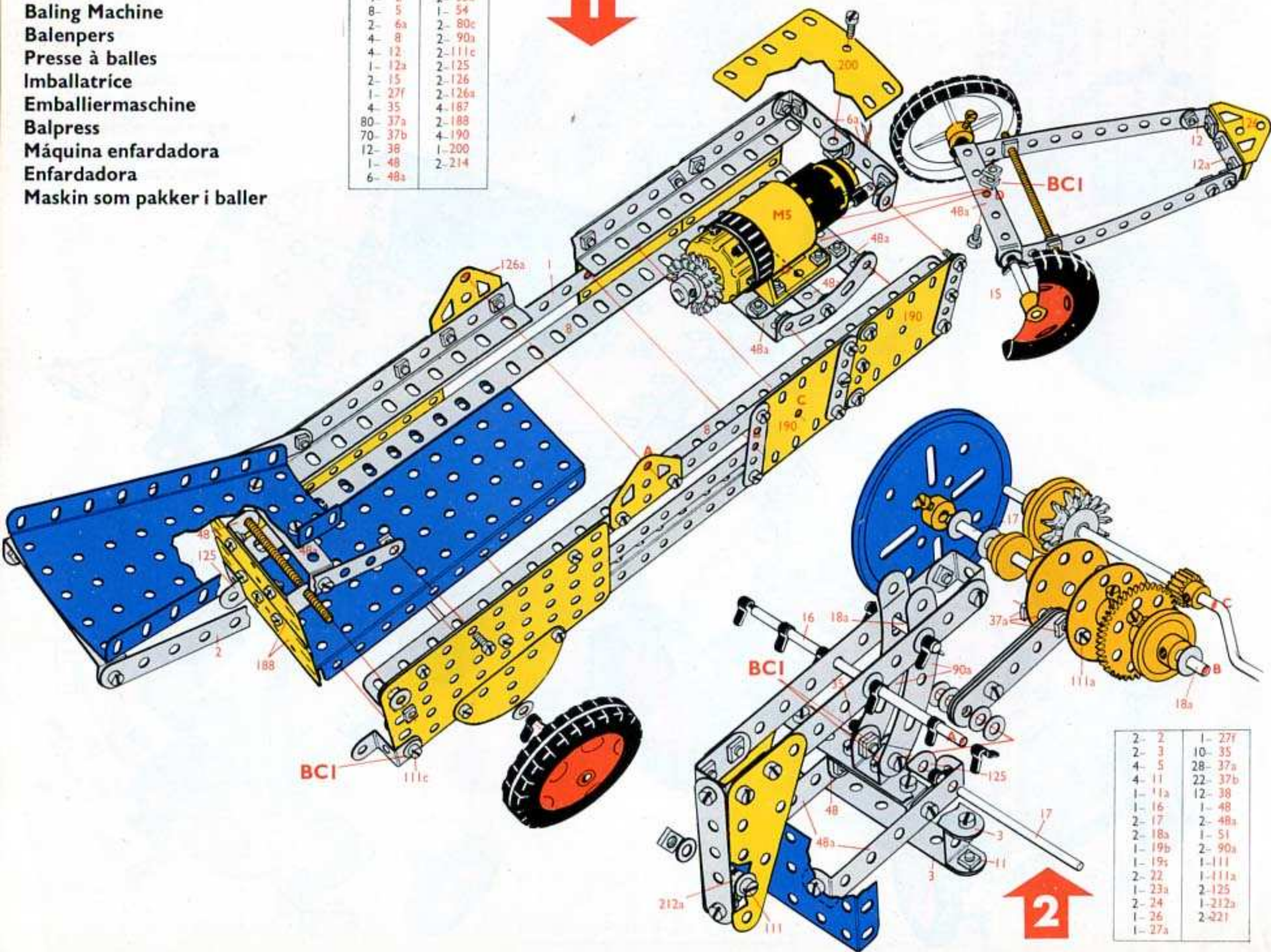

| | | | |
|----|-----|-----|------|
| 2- | 2 | 1- | 27f |
| 2- | 3 | 10- | 35 |
| 4- | 5 | 28- | 37a |
| 4- | 11 | 22- | 37b |
| 1- | 11a | 12- | 38 |
| 1- | 16 | 1- | 48 |
| 2- | 17 | 2- | 48a |
| 2- | 18a | 1- | 51 |
| 1- | 19b | 2- | 90a |
| 1- | 19c | 1- | 111 |
| 2- | 22 | 1- | 111a |
| 1- | 23a | 2- | 125 |
| 2- | 24 | 1- | 212a |
| 1- | 26 | 2- | 221 |
| 1- | 27a | | |



| | | | |
|--------|----------|---------|--------|
| 2- 1 | 2- 18a | 2- 48 | 2-126a |
| 6- 2 | 1- 19b | 8- 48a | 4-187 |
| 2- 3 | 1- 19c | 1- 51 | 2-188 |
| 12- 5 | 2- 22 | 1- 52 | 4-190 |
| 2- 6a | 1- 23a | 2- 53a | 1-200 |
| 4- 8 | 2- 24 | 1- 54 | 1-212a |
| 4- 11 | 1- 26 | 2- 80c | 2- 214 |
| 1- 11a | 1- 27a | 4- 90a | 2- 221 |
| 4- 12 | 2- 27f | 1- 111 | *1- M5 |
| 1- 12a | 14- 35 | 1- 111a | |
| 2- 15 | 108- 37a | 2- 111c | |
| 1- 16 | 92- 37b | 4- 125 | |
| 2- 17 | 24- 38 | 2- 126 | |

*Not included in set No.6

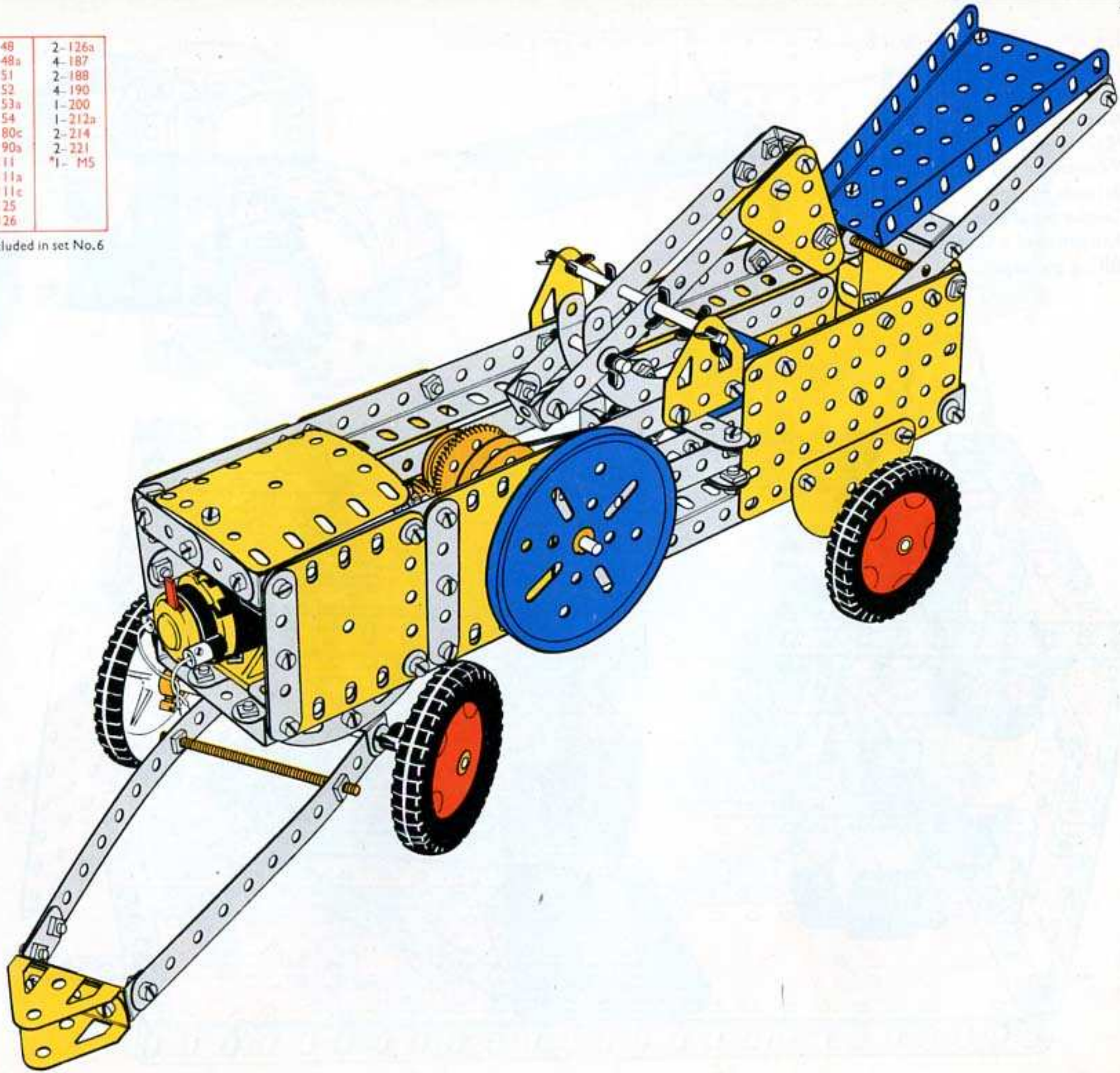

ELECTRONIC 6.16.

Car & Garage
 Auto en garage
 Auto et Garage
 Macchina e autorimessa
 Wagen und Garage
 Bil och garage
 Coche y garage
 Automovel e Garagem
 Bil og garasje

| | | | | | | | |
|-----|-----|------|-----|----|------|----|------|
| 9- | 1 | 1- | 23 | 4- | 48a | 4- | 189 |
| 14- | 2 | 1- | 23a | 1- | 51 | 4- | 190 |
| 7- | 5 | 1- | 23a | 2- | 53a | 2- | 191 |
| 2- | 6a | 2- | 24 | 2- | 54 | 4- | 192 |
| 4- | 8 | 1- | 24c | 2- | 90a | 2- | 193 |
| 1- | 10 | 1- | 26 | 2- | 99 | 2- | 193a |
| 4- | 11 | 1- | 27a | 1- | 111 | 1- | 193c |
| 1- | 11a | 7- | 35 | 2- | 111a | 1- | 193e |
| 2- | 12 | 115- | 37a | 5- | 111c | 2- | 212a |
| 2- | 15 | 93- | 37b | 1- | 115 | 1- | 213 |
| 1- | 15b | 24- | 38 | 2- | 126a | 1- | 214 |
| 1- | 16 | 2- | 38d | 1- | 147b | | |
| 1- | 18a | 1- | 45 | 1- | 186a | | |
| 1- | 19b | 2- | 48 | 4- | 188 | | |

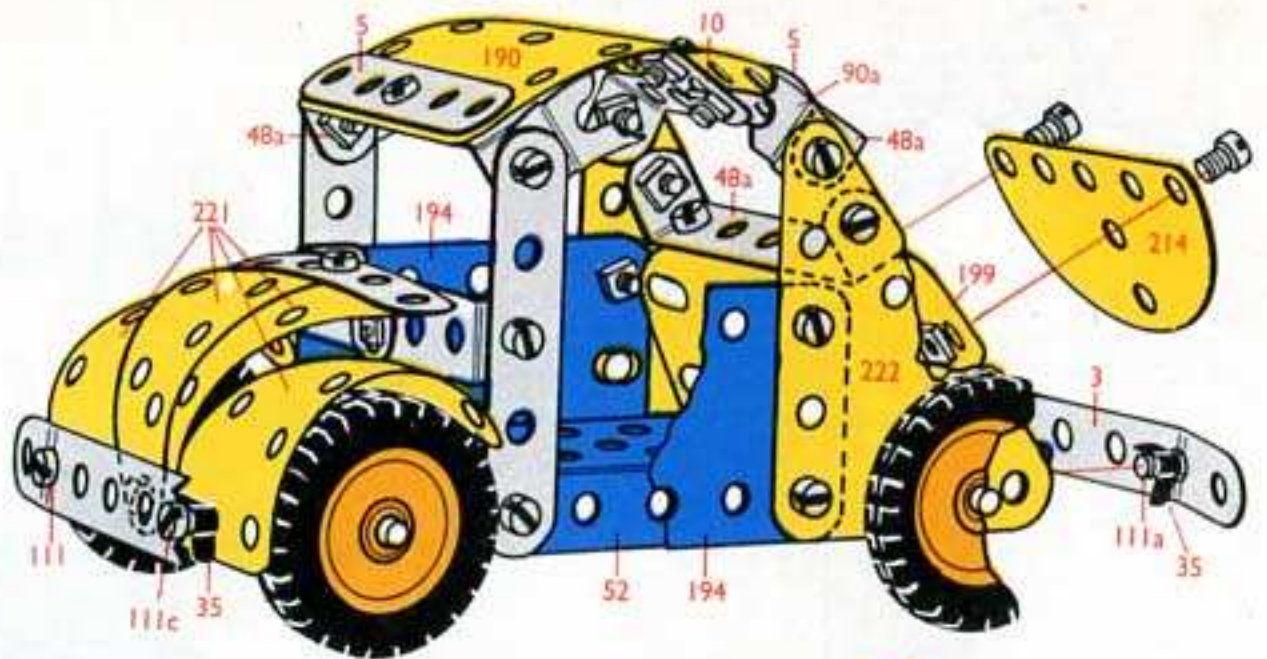

| | | | |
|-----|-----|----|------|
| 2- | 3 | 2- | 90a |
| 5- | 5 | 1- | 111 |
| 1- | 10 | 2- | 111a |
| 1- | 12 | 1- | 111c |
| 2- | 16 | 4- | 142c |
| 4- | 22 | 2- | 194 |
| 4- | 35 | 1- | 199 |
| 28- | 37a | 1- | 200 |
| 24- | 37b | 1- | 214 |
| 4- | 48a | 4- | 221 |
| 1- | 52 | 2- | 222 |

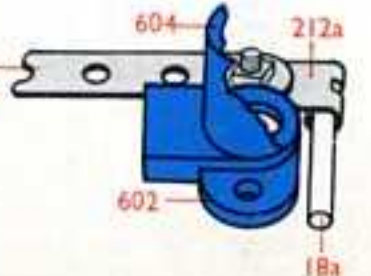
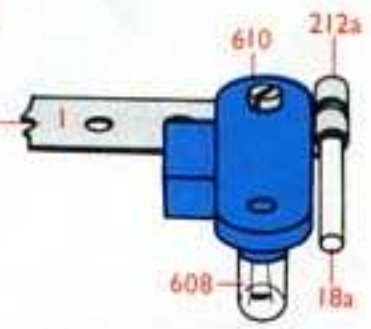
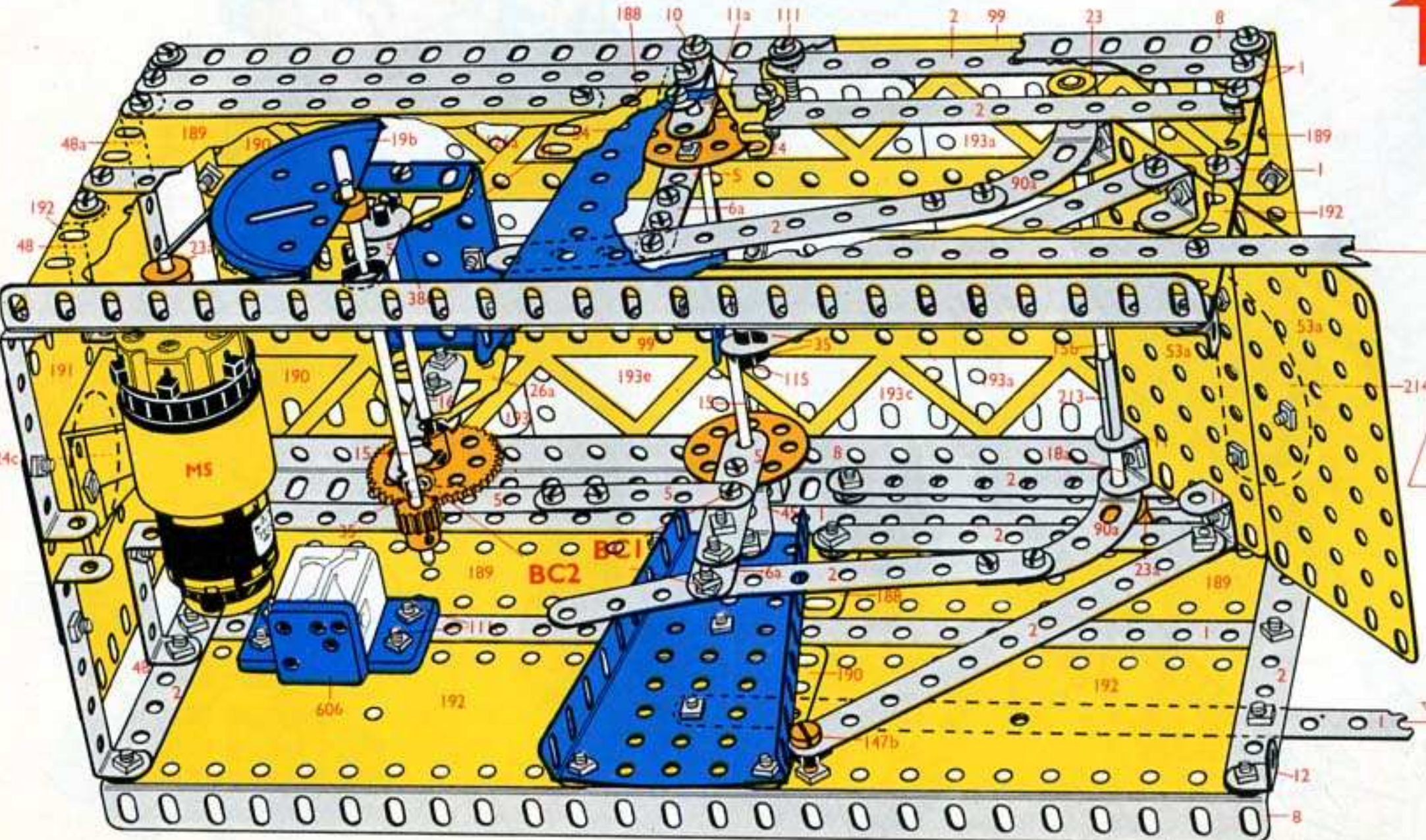

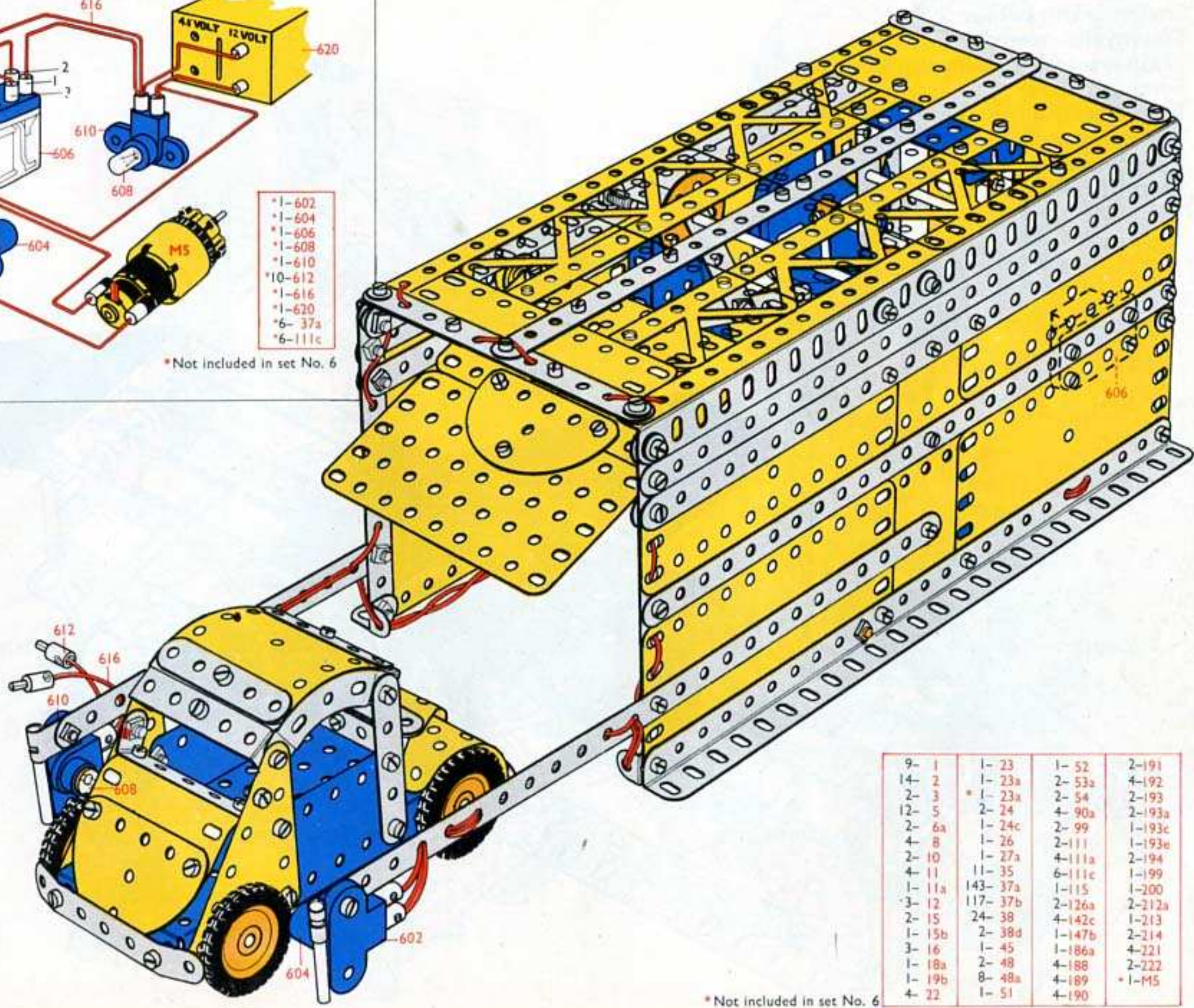
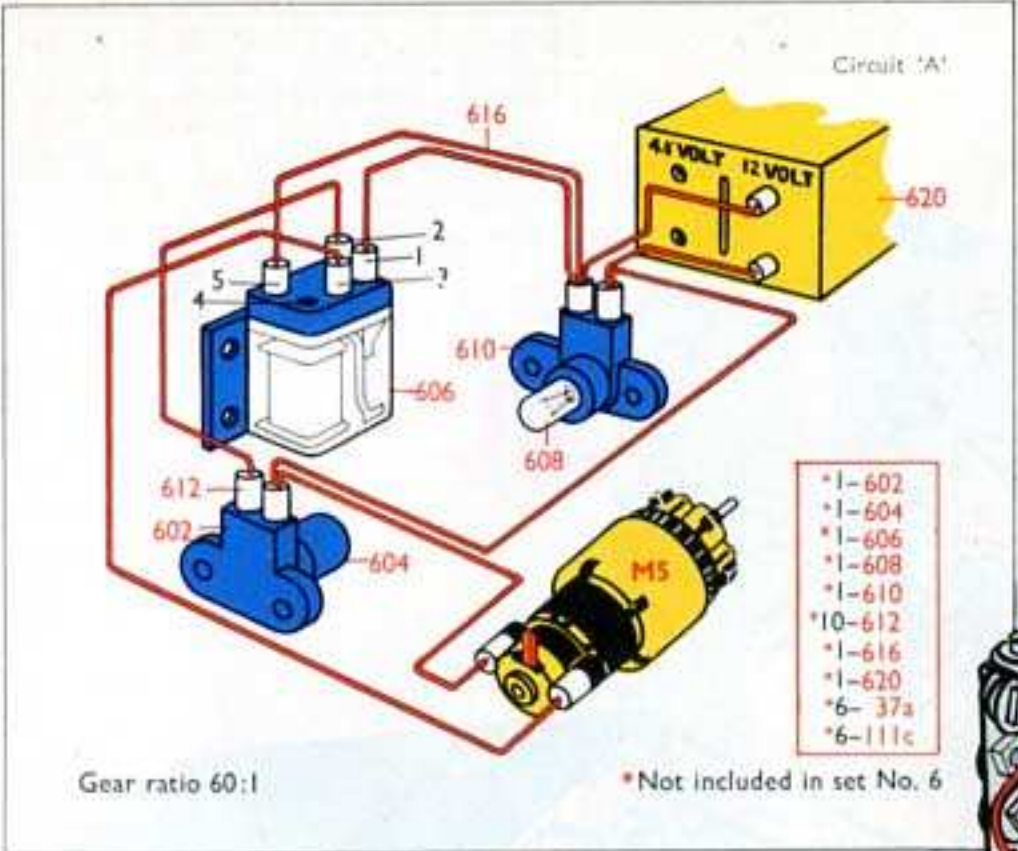

| | | | |
|-------|----------|--------|--------|
| 9- 1 | 1- 23 | 1- 52 | 2-191 |
| 14- 2 | 1- 23a | 2- 53a | 4-192 |
| 2- 3 | *1- 23a | 2- 54 | 2-193 |
| 12- 5 | 2- 24 | 4- 90a | 2-193a |
| 2- 6a | 1- 24c | 2- 99 | 1-193c |
| 4- 8 | 1- 26 | 2-111 | 1-193e |
| 2-10 | 1- 27a | 4-111a | 2-194 |
| 4-11 | 11- 35 | 6-111c | 1-199 |
| 1-11a | 143- 37a | 1-115 | 1-200 |
| 3-12 | 117- 37b | 2-126a | 2-212a |
| 2-15 | 24- 38 | 4-142c | 1-213 |
| 1-15b | 2- 38d | 1-147b | 2-214 |
| 3-16 | 1- 45 | 1-186a | 4-221 |
| 1-18a | 2- 48 | 4-188 | 2-222 |
| 1-19b | 8- 48a | 4-189 | *1-M5 |
| 4-22 | 1- 51 | 4-190 | |

* Not included in set No. 6

ELECTRONIC 6.17.

Sorting Conveyor
 Sorteertransporteur
 Convoyeur-trieur
 Trasportatore classificatore
 Sortierförderer
 Sorteringstransportör
 Transportador clasificador
 Transportador Seleccionador
 Sorteringstransportor

| | | | |
|--------|---------|--------|---------|
| 2- 1 | 1- 20a | 24- 38 | 1-115 |
| 1- 2 | 4- 22 | 1- 40 | 2-125 |
| 2- 3 | 2- 22a | 2- 48 | 2-126 |
| 5- 5 | 1- 23a | 3- 48a | 1-147b |
| 1- 6a | 2- 24 | 1- 51 | 1-186a |
| 2- 8 | 1- 26 | 1- 52 | *1-186b |
| 5- 12 | 1- 27a | 2- 54 | 2-212 |
| 2- 12a | 12- 35 | 2- 99 | *1-M5 |
| 1- 15b | 46- 37a | 1-111a | |
| 4- 16 | 44- 37b | 2-111c | |

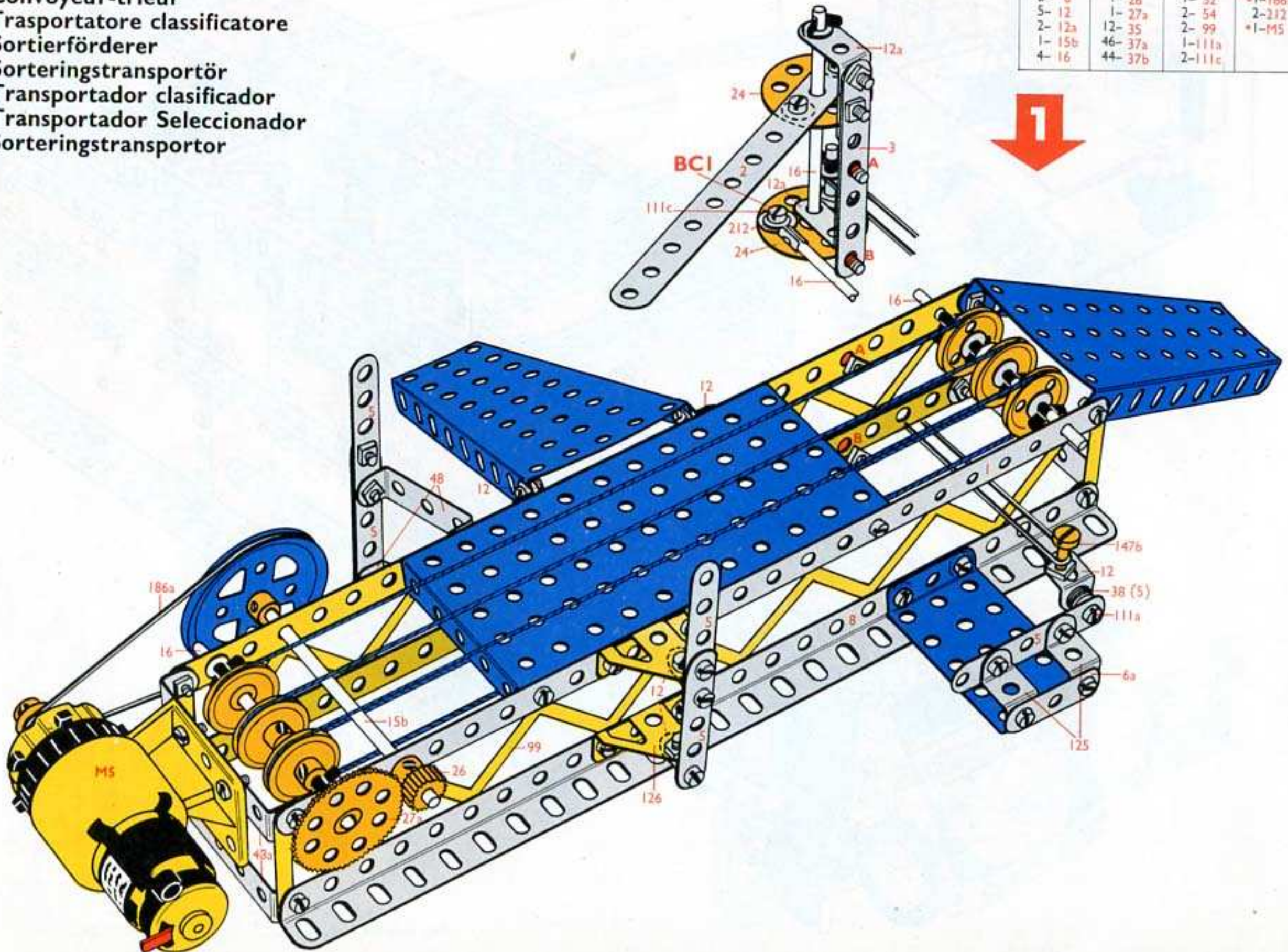

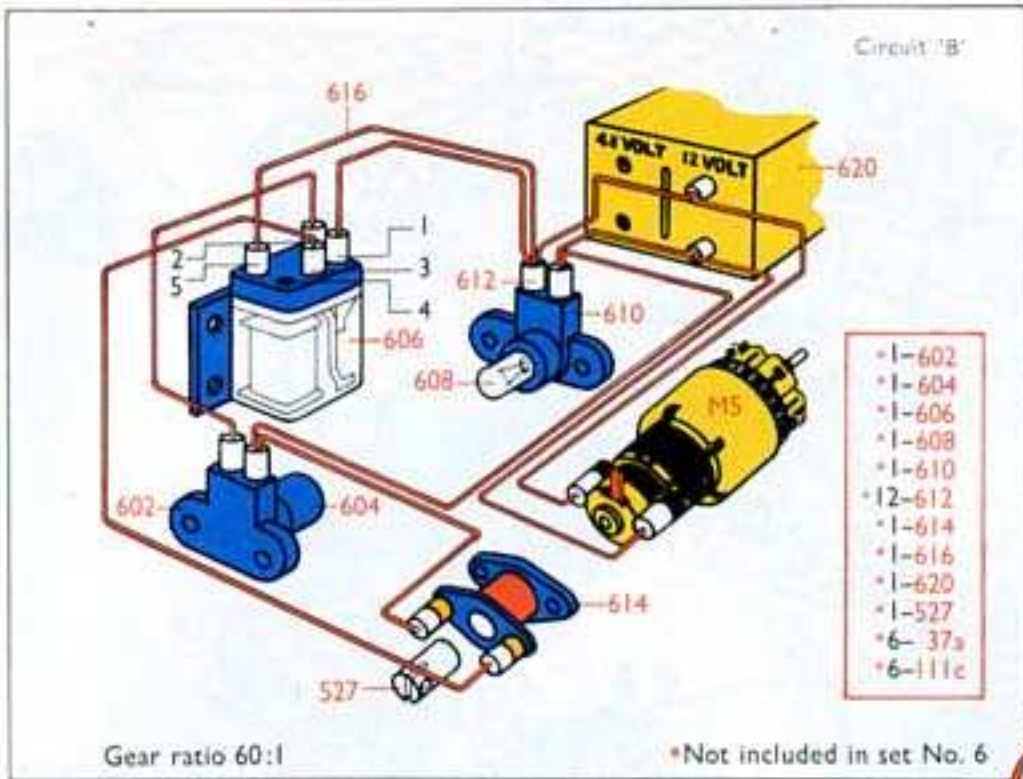

| | | | |
|-------|---------|--------|---------|
| 2- 1 | 1- 20a | 24- 38 | 1-115 |
| 1- 2 | 4- 22 | 1- 40 | 2-125 |
| 2- 3 | 2- 22a | 2- 48 | 2-126 |
| 5- 5 | 1- 23a | 3- 48a | 1-147b |
| 1- 6a | 2- 24 | 1- 51 | 1-186a |
| 2- 8 | 1- 26 | 1- 52 | *1-186b |
| 5-12 | 1- 27a | 2- 54 | 2-212 |
| 2-12a | 12- 35 | 2- 99 | *1-M5 |
| 1-15b | 46- 37a | 1-111a | |
| 4- 16 | 44- 37b | 2-111c | |

*Not included in set No. 6

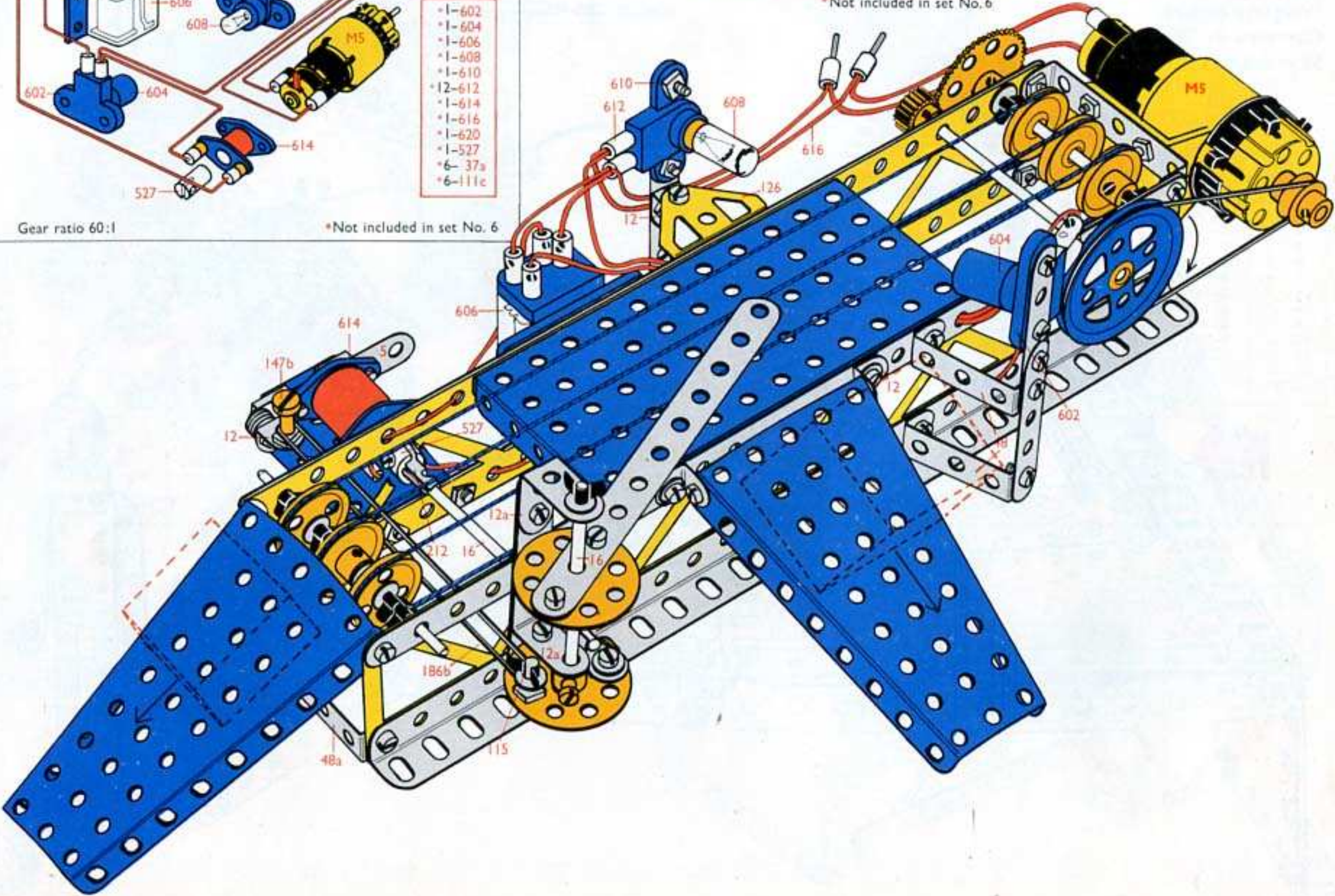

ELECTRONIC 6.18.

Shooting Range
 Schietbaan
 Tir
 Tiro a segno
 Schiessstand
 Skjutbana
 Poligono de tiro
 Carreira de Tiro
 Skytebane

| | |
|---------|----------|
| 1- 1 | 1- 23a |
| 1- 5 | 2- 24 |
| 2- 16 | 2- 27f |
| 1- 18a | 8- 37a |
| 1- 18b | 6- 37b |
| 1- 19b | 6- 38 |
| 1- 20a | 1- 186a |
| 2- 22 | *1- 186b |
| 1- 23 | 1- 213 |
| *1- 23w | 1- 214 |

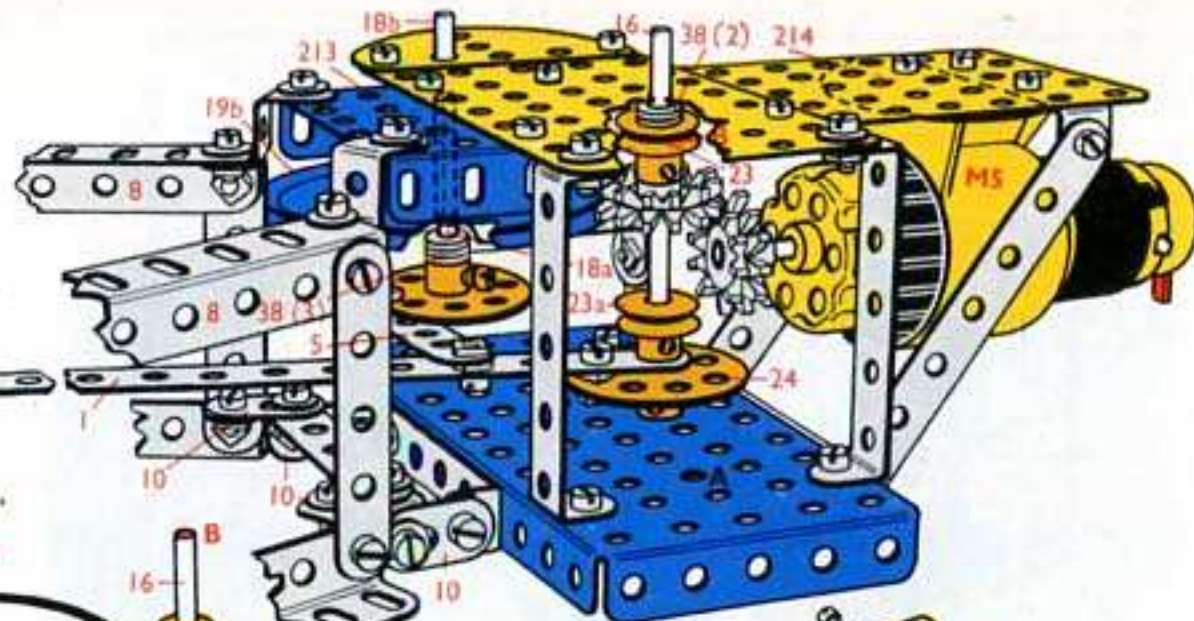

2

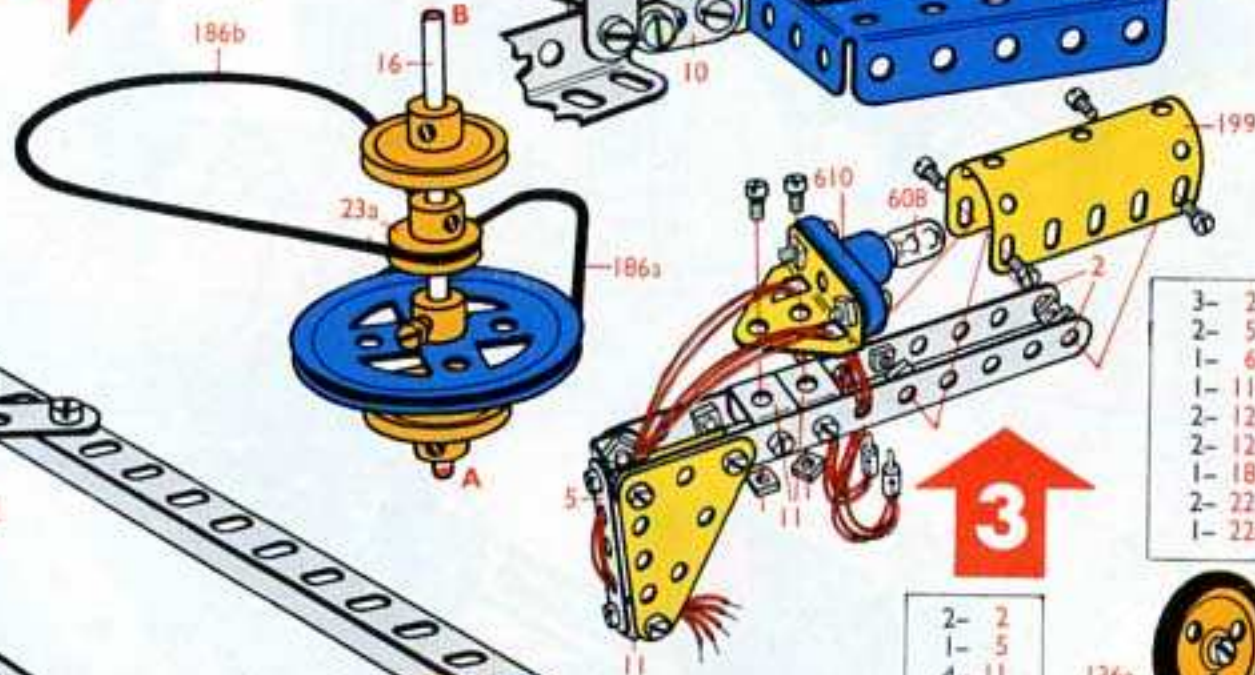

3

| | |
|--------|---------|
| 3- 2 | 15- 37a |
| 2- 5 | 15- 37b |
| 1- 6a | 4- 38 |
| 1- 11a | 1- 90a |
| 2- 12 | 1- 126 |
| 2- 12c | 1- 126a |
| 1- 18a | 2- 142c |
| 2- 22 | 1- 155 |
| 1- 22a | 1- 188 |

| |
|---------|
| 2- 2 |
| 1- 5 |
| 4- 11 |
| 18- 37a |
| 18- 37b |
| 1- 126 |
| 1- 199 |
| 2- 221 |

4

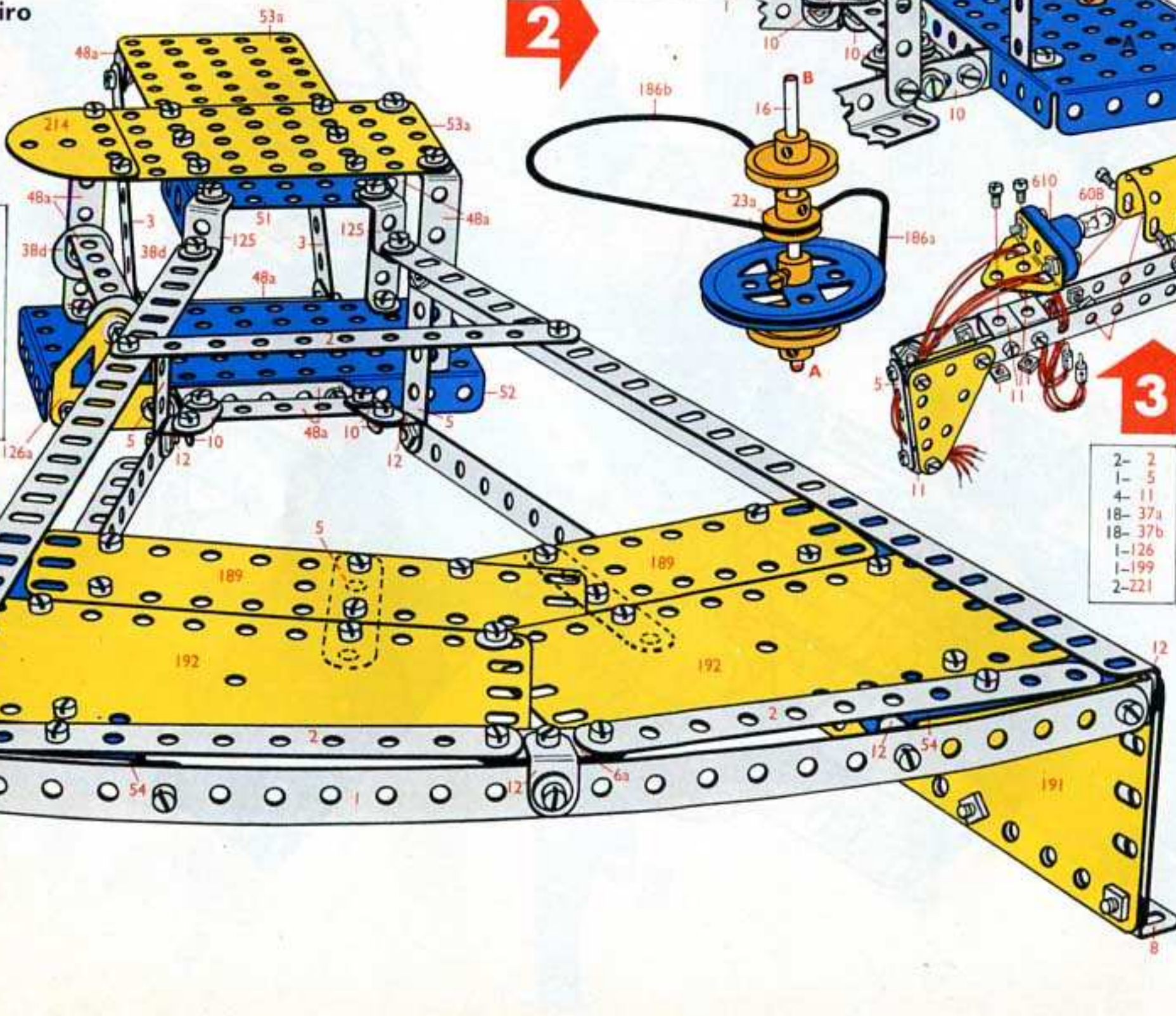
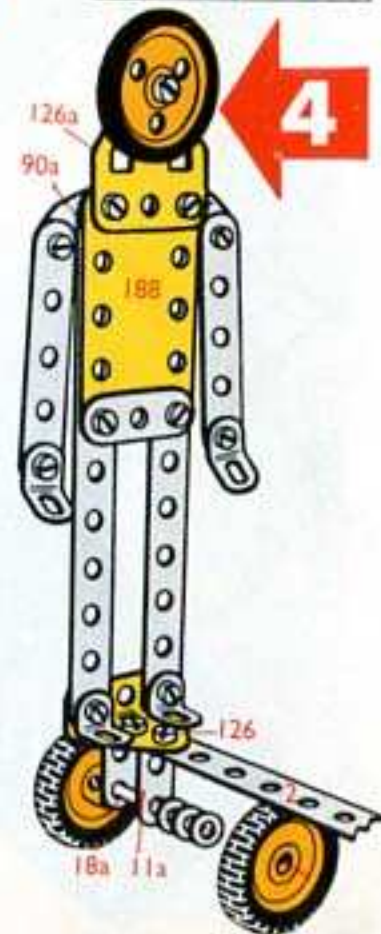

1

| | |
|---------|---------|
| 1- 1 | 8- 48a |
| 3- 2 | 1- 51 |
| 2- 3 | 1- 52 |
| 8- 5 | 2- 53a |
| 1- 6a | 2- 54 |
| 4- 8 | 2- 125 |
| 4- 10 | 1- 126a |
| 7- 12 | 2- 189 |
| 82- 37a | 2- 191 |
| 82- 37b | 2- 192 |
| 12- 38 | 1- 214 |
| 2- 38d | |

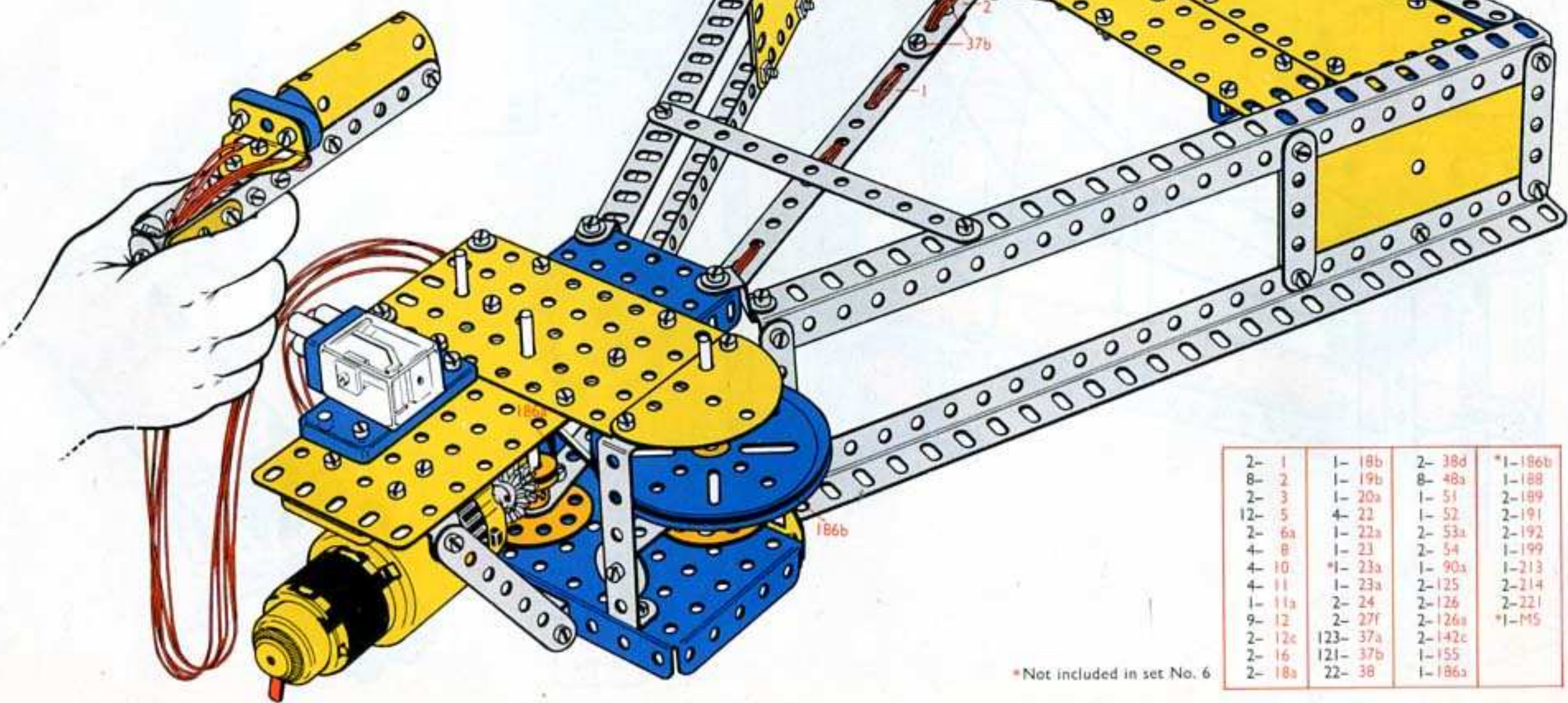
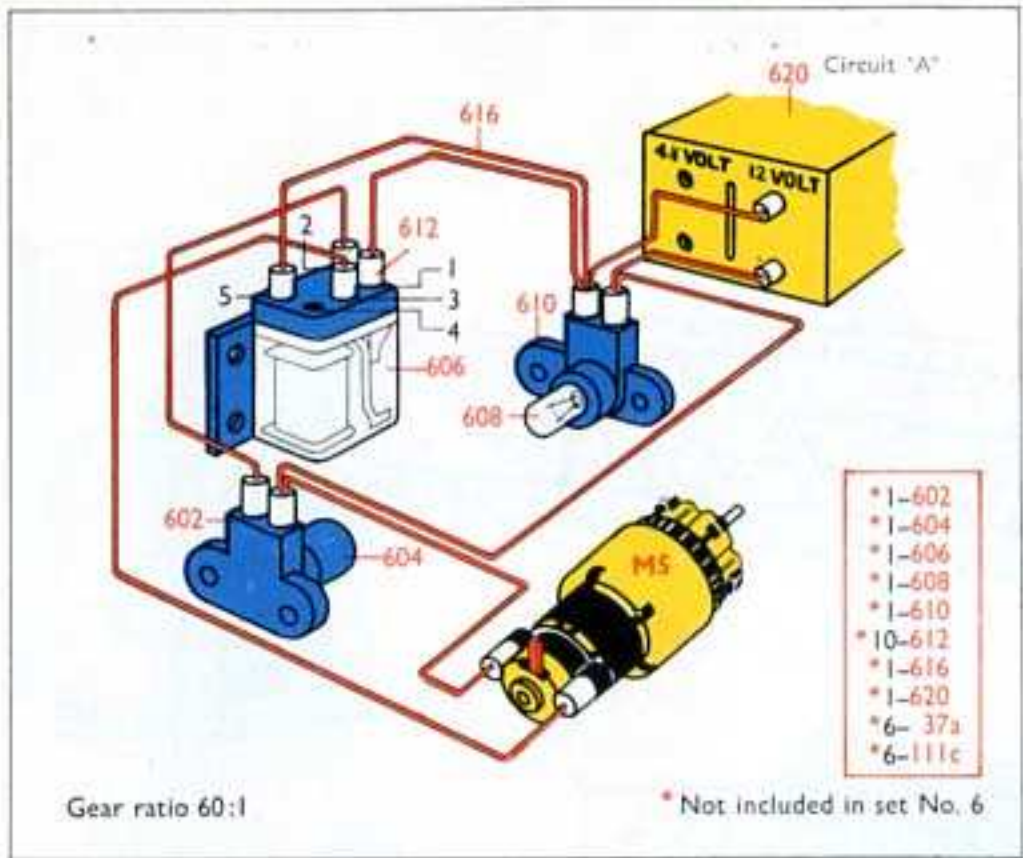

MECCANO—THE PROGRESSIVE SYSTEM

The standard Meccano system consists of a range of Main Sets numbered from 1 to 10, which get progressively larger as the Set number increases. This means that Set 2 contains all the parts included in Set 1, plus a quantity of additional Parts, while Set 3 contains all the Parts in Set 2, plus a further quantity of additional Parts, and so on, right up to the No. 10 Set.

Also included in the standard system is a series of eight Conversion Sets. These are not intended as constructional sets in their own right, but simply contain the necessary extra Parts to convert a main Set into the next larger, e.g. Set 1 together with Conversion Set 1X makes Set 2, and so on. Also available is a series of motorised Sets: 3M, 4M, and 5ME. These are equivalent to Main Sets 3, 4, and 5 with the addition of a Meccano Motor—the Junior Power Drive Unit in Sets 3M and 4M and the Power Drive Unit in the 5ME Set. The 5ME Set also includes the components contained in the Electronics Accessory Set.

Other current outfits are the Gears and Mechanisms Sets, both of which contain a selection of standard gears to further mechanise your models, and the 4EL Set equivalent to the standard No. 4 set with the addition of special electrical parts.

MECCANO—IL SISTEMA PROGRESSIVO

Il Sistema Meccano standard è costituito da una serie di Scatole Base numerate da 1 a 10 che, con il crescere del numero, diventano progressivamente più grandi e più complete. La Scatola 2 contiene tutti i Pezzi compresi nella Scatola 1 più un certo numero di Pezzi addizionali; la Scatola 3 contiene tutti i Pezzi della Scatola 2 più un certo numero di Pezzi addizionali, e così via fino al Meccano 10.

Il Sistema Meccano comprende inoltre 8 Scatole di Conversione, le quali non possono essere utilizzate da sole, ma contengono i Pezzi necessari per convertire una Scatola Base in quella immediatamente più grande, per esempio la Scatola 1 più la Scatola di Conversione 1X formano la Scatola 2 e così via.

L'assortimento Meccano comprende anche Scatole motorizzate 3M, 4M, 5ME e 6ME, che sono equivalenti alle Scatole Base 3, 4, 5 e 6 ciascuna con l'aggiunta di un Motorino Meccano: il Motorino Elettrico Junior nelle Scatole 3M e 4M, e il Motorino Elettrico con Cambio a 6 Velocità nella Scatola 5ME.

Nella Scatola 5ME sono incluse anche Parti Meccano della Serie Elettronica. Fanno parte del sistema Meccano anche le Scatole Ingranaggi e Meccanismi contenenti vari ingranaggi standard Meccano che servono per "meccanizzare" maggiormente i modelli e la Scatola 4-EL corrispondente alla Scatola 4 però con l'aggiunta di speciali pezzi elettrici.

MECCANO—EL JUGUETE PROGRESIVO

El Meccano standard se compone de una serie de Juegos Básicos, numerados de 1 a 10, cuyo surtido de piezas aumenta progresivamente según el número de referencia del juego. Es decir, el Juego No. 2 contiene todas las piezas incluidas en el No. 1 más una serie de elementos adicionales; el Juego 3 tiene todas las piezas del No. 2 complementadas con varias más, y así sucesivamente hasta el Juego No. 10.

En el Meccano standard figura también una serie de Equipos de Conversión. Estos no son juegos de construcción propiamente dichos, sino que reúnen los complementos necesarios para convertir un Juego Básico determinado en el del número siguiente. Por ejemplo, el Juego No. 1 y el Equipo de Conversión 1X forman el Juego 2, etc. etc. Se ofrece también una serie de juegos motorizados: 3M, 4M y 5ME, los cuales equivalen a los Juegos Básicos 3, 4 y 5 complementados con un Motor Meccano (unidad motriz Junior Power en los nos 3M y 4M unidad motriz Power en 5ME). El Juego 5ME contiene también las piezas comprendidas en el Equipo de Accesorios Electrónicos.

Entre otros equipos comprendidos en la serie actual se encuentran los juegos de engranajes y mecanismos, ambos de los cuales cuentan con una selección de ruedas dentadas standard para mecanizar aún más el funcionamiento de sus modelos, así como el Juego 4 EL que equivale al juego standard no. 4 complementado con piezas eléctricas especiales.

MECCANO—HET PROGRESSIEVE SYSTEEM

Het standaard Meccano-systeem omvat een serie hoofd-sets, genummerd van 1 t/m 10, die progressief groter worden met het opklimmen van de nummers. Dit betekent dat set 2 alle onderdelen bevat van set 1, plus een aantal extra onderdelen, terwijl set 3 alle onderdelen van set 2 bevat, plus een aantal extra onderdelen, enz., tot set no. 10.

Tevens omvat het standaard systeem een serie uitbreidingssets, nl. 8 stuks. Deze zijn niet bedoeld als op zichzelf staande constructiesets, maar bevatten de noodzakelijke extra onderdelen om een hoofdsat uit te breiden tot het volgende set-nummer, zodat bijvoorbeeld Set No. 1 tezamen met de uitbreidingsset 1X gelijk wordt aan Set No. 2, enz. Ook zijn gemotoriseerde sets leverbaar, nl. 3M, 4M, en 5ME. Deze zijn gelijkwaardig aan de hoofdsats 3, 4 en 5 met toevoeging van een Meccano motor—de Junior Power Drive Unit (Junior drijfwerkuitrusting) in sets 3M en 4M de drijfwerkuitrusting in 5ME. Set 5ME bevat ook de onderdelen uit de elektronische uitbreiding set.

Andere nieuwe uitrustingen omvatten tandwiel-en gemechaniseerde sets, die beide een serie standard tandwielen bevatten om de modellen verder te mechaniseren. Tevens is de set 4 EL leverbaar, die gelijk is aan de standaard set no. 4, met bijvoeging van speciale elektrische onderdelen.

MECCANO—DAS STUFENWEISE AUSBAUBARE SYSTEM

Das Meccano-Standardssystem besteht aus einer Reihe von Hauptkästen, die mit den Zahlen 1 bis 10 bezeichnet sind; diese Bausätze werden umfassender, je höher die Kennziffer ist, d.h. dass Bausatz 2 nicht nur alle Teile von Kasten 1 enthält, sondern ausserdem eine Reihe von Zusatzteilen. Das gleiche gilt für Satz 3; er verfügt über alle Teile aus Satz 2 und daneben über zahlreiche Zusatzteile. Das geht so weiter bis Satz 10.

Zum Standardssystem gehören weiterhin eine Reihe von acht Ergänzungskästen. Sie sind nicht als eigenständige Bausätze gedacht, sondern umfassen lediglich die notwendigen Zusatzteile, um einen Hauptkasten so zu vervollständigen, dass er der nächst höheren Stufe entspricht; das bedeutet z.B., dass Satz 1 plus Ergänzungskasten 1X über die gleiche Anzahl von Teilen verfügt, wie sie in Satz 2 vorliegen usw. Weiterhin sind Bausätze mit Motor erhältlich: 3M, 4M und 5ME. Sie entsprechen den Kästen 3, 4 und 5 und enthalten ausserdem einen Meccano-Antriebsmotor; bei Satz 3M und 4M handelt es sich dabei um die Junior-Antriebseinheit, bei 5ME um die grosse Einheit. Der Kasten 5ME umfasst weiterhin die Einzelteile aus dem Elektronikbauteilekasten.

Weitere erhältliche Kästen umfassen Sätze mit Zahnrädern, Getrieben und anderen Teilen, die eine Reihe von Standardbauteilen enthalten, mit deren Hilfe die gebauten Modelle noch weiter mechanisiert werden können. Der Satz 4 EL umfasst neben den Standardbauteilen des Kastens Nr. 4 zusätzliche Elektrobauteile.

MECCANO—O SISTEMA PROGRESSIVO

O sistema normal Meccano consiste numa linha de Jogos Principais numerados de 1 a 10, que se tornam progressivamente maiores à medida que o número do jogo aumenta. Isto significa que o Jogo No. 2 tem todas as peças incluídas no Jogo No. 1, mais um certo número de peças adicionais; o Jogo No. 3 contém todas as peças do Jogo No. 2 mais um certo número de peças adicionais e assim por diante, até ao Jogo No. 10.

Incluída no sistema normal está uma série de oito Jogos de Conversão. Estes jogos por si só não são jogos de construção, mas contêm simplesmente o número de peças extras necessárias a converter um Jogo Principal no jogo que se lhe segue, isto é o Jogo No. 1 juntamente com o Jogo de Conversão 1X completa o Jogo No. 2, e assim por diante. Também se encontra à venda uma série de Jogos com motores: 3M, 4M e 5ME. Estes são equivalentes aos Jogos Principais Nos. 3, 4 e 5 mais com um motor Meccano—a Unidade de Accionamento Junior nos Jogos 3M e 4M e a Unidade de Accionamento no Jogo 5ME. O Jogo 5ME também inclui os componentes do Jogo de Accesorios Electrónicos.

Outros equipamentos de fabrico corrente são os conjuntos de Engrenagens e Mecanismos os quais têm uma seleção de engrenagens normais para tornar os modelos ainda mais mecanizados, e o Jogo 4 EL, equivalente ao jogo normal No. 4 tem ainda peças eléctricas especiais.

MECCANO—LE SYSTEME PROGRESSIF

Le système Meccano consiste en une série de boîtes principales, numérotées de 1 à 10, et dont l'importance augmente avec le numéro de série. Cela signifie que la boîte No. 2 contient toutes les pièces de la boîte No. 1, plus un certain nombre de pièces supplémentaires. Il en est de même pour la boîte No. 3 qui contient toutes les pièces du No. 2 auxquelles s'ajoutent un certain nombre de pièces supplémentaires, et ainsi de suite jusqu'au 10.

Une série de huit boîtes complémentaires fait également partie de ce système. Cependant, ce ne sont pas des boîtes de construction car elles ne contiennent que les pièces supplémentaires nécessaires à la conversion d'une boîte donnée en celle du numéro suivant; par exemple, la boîte complémentaire 2X transforme une boîte 2 en boîte 3, et ainsi de suite. Il existe également une série de boîtes motorisées: 3M, 4M et 5ME. Celles-ci correspondent très exactement aux boîtes 3, 4 et 5, avec l'addition d'un moteur Meccano, le 'Junior Power Drive Unit' pour les boîtes 3M et 4M et le 'Power Drive Unit' dans la boîte 5ME. La boîte 5ME comprend également les éléments contenus dans la boîte d'accessoires électroniques. Les autres accessoires courants comprennent des jeux de mécanismes et d'engrenages qui contiennent tous deux une sélection d'engrenages standard permettant la mécanisation de vos modèles, et le jeu 4 EL, équivalent du jeu standard No. 4 avec des éléments électriques spéciaux supplémentaires.

MECCANO—DET UTBYGGBARA SYSTEMET

Meccano standardsystem består av en serie huvudbyggsatser från 1 till 10, vilka ökar i storlek med numret. Detta innebär, att sats 2 innehåller alla delarna i sats 1 plus ett antal extra delar och att sats 3 innehåller alla delarna i sats 2 plus ytterligare ett antal extra delar o.s.v. ända upp till sats 10.

I standardsystemet ingår också en serie på åtta tilläggsatser. Dessa är inte avsedda att vara byggsatser i sin egen rätt utan innehåller helt enkelt de erforderliga extra delar, som behövs för att förvandla en huvudbyggsats till närmaste större sats. Sats 1 i förening med tilläggsats 1X till exempel resulterar i sats 2 o.s.v. Dessutom finns det en serie motorsatser: 3M, 4M och 5ME. De motsvarar huvudbyggsatserna 3, 4 och 5 med tillägg av en Meccanomotor—Junior drivaggregat i satserna 3M och 4M samt det kraftigare drivaggregatet i sats 5ME. Sats 5ME innehåller också delar, vilka ingår i elektronikbikhangsatsen.

Annan nuvarande utrustning utgörs av kugghjul och mekanismer, och båda dessa slags uppsättningar innehåller ett urval standarddrev för ytterligare mekanisering av modellerna. Uppsättning 4 EL motsvarar standard-upsättning 4, med tillägg av speciella elektriska detaljer.

MECCANO—DET GRADVISE SYSTEMET

Meccanos standardsystem består av en rekke hovedsett som er nummererte fra 1 til 10 og som blir gradvis større i takt med nummereringen. Dette vil si at Sett 2 inneholder alle delene i Sett 1, pluss noen tilleggsdeler, mens Sett 3 inneholder alle delene i Sett 2, pluss ytterligere deler. Og så videre, like til Sett nr. 10.

Inkludert i standardsystemet er også en serie på åtte omdannings-sett. Disse er ikke ment som byggesett i seg selv, men inneholder bare ganske enkelt de nødvendige ekstra deler som skal til for å omdanne et hovedsett til neste størrelse. F.eks.: Sett 1 sammen med omdanningssett 1X utgjør Sett 2 osv. I tillegg til dette er der en serie motorsett: 3M, 4M og 5ME. Disse tilsvarer hovedsettene 3, 4 og 5 med tillegg av en Meccano motor—Junior Power Drive Unit i Settene nr. 3M og 4M, og Power Drive Unit i Sett nr. 5ME. Sett 5ME inneholder også de delene som inngår i Elektrikk-reservsettet.

Andre sett som kan fåes er gir- og mekanisme-settene; begge disse inneholder et utvalg av standard gir slik at modellene kan mekaniseres ytterligere, og 4 EL settet som tilsvarer standard sett nr. 4, men med tillegg av spesielle elektriske deler.



51 FLANGED PLATES
 51 - 2½" × 1½"; 60 × 38 mm
 52 - 5½" × 2½"; 14 × 6 cm
 53 - 3½" × 2½"; 9 × 6 cm



52 FLAT PLATES
 52a - 5½" × 3½"; 14 × 9 cm
 53a - 4½" × 2½"; 11½ × 6 cm



54 FLANGED SECTOR PLATE
 54 - 4½"; 115 mm



PERFORATED SLOTTED STRIP
 55 - 5½"; 14 cm
 55a - 2"; 5 cm



57b HOOK



57c HOOK



57d WIRE HOOK



58 SPRING CORD - 40"; 1 metre



59 COLLAR WITH SCREW



58a COUPLING SCREW FOR 58



58b HOOK FOR 58



61 WINDMILL SAIL



62 CRANK



62a THREADED CRANK



62b DOUBLE ARM CRANK



63 COUPLING



63c THREADED COUPLING



63b STRIP COUPLING



63d SHORT COUPLING



64 THREADED BOSS



65 CENTRE FORK



69 SET SCREW



69a GRUB SCREW



69b GRUB SCREW



69c GRUB SCREW



69d GRUB SCREW



70 FLAT PLATES
 70 - 5½" × 2½"; 14 × 6 cm
 72 - 2½" × 2½"; 6 × 6 cm
 73 - 3" × 1½"; 75 × 38 mm
 74 - 1½" × 1½"; 38 × 38 mm

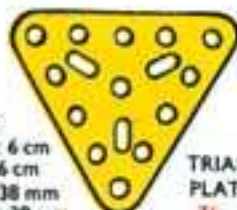

76 TRIANGULAR PLATES
 76 - 2½"; 6 cm
 77 - 1"; 25 mm



78 SCREWED RODS
 78 - 1½"; 29 cm
 79 - 8"; 20 cm
 79a - 6"; 15 cm
 80 - 5"; 12½ cm
 80a - 3½"; 9 cm
 80b - 4½"; 11½ cm
 80c - 3"; 7½ cm
 81 - 2"; 5 cm
 82 - 1"; 25 mm



89 CURVED STRIP
 89 - 5½"; 14 cm
 90 - 2½"; 6 cm



94 SPROCKET CHAIN
 94 - 40"; 1 metre



95 SPROCKET WHEELS
 95 - 2"; 5 cm
 95a - 1½"; 38 mm
 95b - 3"; 75 mm
 96 - 1"; 25 mm
 96a - 2"; 19 mm

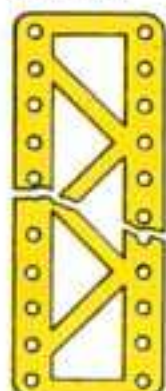

97 BRACED GIRDELS
 97 - 3½"; 9 cm
 99 - 1½"; 32 cm
 99a - 9"; 24 cm
 99b - 7"; 19 cm
 100 - 5½"; 14 cm



101 HEALD FOR LOOM



102 SINGLE BENT STRIP



103 FLAT GIRDELS
 103 - 5½"; 14 cm
 103a - 9"; 24 cm
 103b - 12½"; 32 cm
 103c - 4½"; 11½ cm
 103d - 3½"; 9 cm
 103e - 3"; 7½ cm
 103f - 2½"; 6 cm
 103g - 2"; 5 cm
 103h - 1½"; 38 mm
 103i - 7"; 19 cm



106 WOOD ROLLER

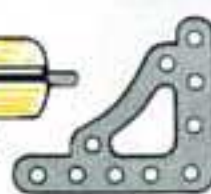

108 CORNER GUSSET



109 FACE PLATE
 109 - 2½"; 6 cm



110 RACK STRIPS
 110 - 3½"; 9 cm
 110a - 6½"; 16½ cm

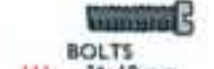

111 BOLTS
 111 - 2"; 19 mm
 111a - 1"; 12 mm
 111c - 1"; 9½ mm
 111d - 1½"; 28½ mm

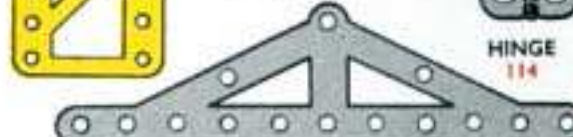

113 GIRDER FRAME



114 HINGE



115 THREADED PINS
 115 - 1½"; 15 mm
 115a long 1½"; 34 mm



116a FORK PIECE LARGE



116b FORK PIECE SMALL

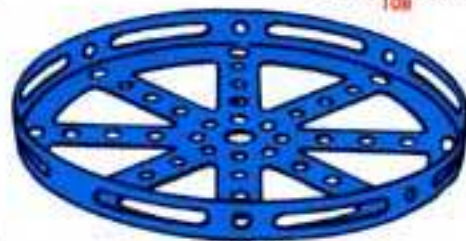

118 HUB DISC
 118 - 5½"; 14 cm



120 COMPRESSION SPRING
 120b - 1½"; 14 mm



122 LOADED SACK



123 CONE PULLEY
 123 - 1½" × 1" × 2"; 32 × 25 × 19 mm



124 REVERSED ANGLE BRACKETS
 124 - 1"; 25 mm
 125 - 1½"; 12 mm



126 TRUNNION



126a FLAT TRUNNION



128 BELL CRANK



130 ECCENTRIC TRIPLE THROW
 130 - 1½" × 1½" × 1½"; 6 × 9 × 12 mm



130a ECCENTRIC SINGLE THROW
 130a - 1½"; 6 mm



131 CAM

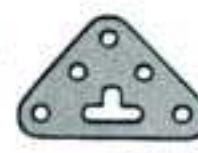

133 CORNER BRACKETS
 133 - 1½"; 38 mm
 133a - 1"; 25 mm



134 CRANK SHAFT
 134 - 1"; 25 mm



136 HANDRAIL SUPPORT



136a HANDRAIL COUPLING



137 WHEEL FLANGE



138 SHIP'S FUNNEL



139 FLANGED BRACKET
 139 (right)
 139a (left)



140 UNIVERSAL COUPLING



142 MOTOR TYRES
 142a - 2"; 5 cm
 142b - 3"; 7½ cm
 142c - 1"; 25 mm
 142d - 1½"; 38 mm



143 CIRCULAR GIRDER
 143 - 5½"; 14 cm



144 DOG CLUTCH



145 CIRCULAR STRIP
 145 - 7½"; 19 cm

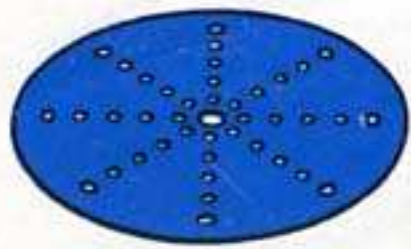

CIRCULAR PLATES
146a - 4"; 10 cm
146b - 6"; 15 cm



PAWL WITH PIVOT BOLT & NUTS
147



PAWL
147a



PIVOT BOLT
147b



147c PAWL WITHOUT BOSS



RATCHET WHEEL
148



PULLEY BLOCKS
153 TRIPLE
151 SINGLE



CORNER ANGLE BRACKET
154a - 1/2"; 12 mm (right)
154b - 1/2"; 12 mm (left)



RUBBER RING
155 - 1"; 25 mm



FAN
157 - 2"; 5 cm



CHANNEL BEARING
160 - 1 1/2" x 1" x 1/2"
38 x 25 x 12 mm



GIRDER BRACKET
161 - 2" x 1" x 1/2"
50 x 25 x 12 mm

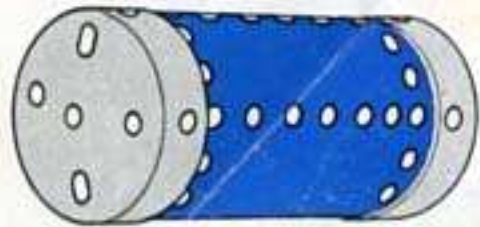

BOILER
162 BOILER COMPLETE - 5" x 2 1/2"; 12 1/2 x 5 cm
162a BOILER END - 2 1/4" x 1/2"; 50 x 19 mm



SLEEVE PIECE
163 - 1 1/2" x 1/2"; 38 x 17 mm



CHIMNEY ADAPTOR
164 - 1/2" x 1/2"; 16 x 12 mm



SWIVEL BEARING
165



END BEARING
166



LARGE TOOTHED QUADRANT PINION
167c



FLANGED RING
167b - 9 1/4"; 25 cm



LARGE TOOTHED QUADRANT
167a



BALL THRUST BEARING COMPLETE 4"; 10 cm
168a AND 168b BALL THRUST RACES
168c BALL CAGE



BALL
168d - 3/8"; 9 1/2 mm



ADAPTOR FOR SCREWED ROD
173a



ROD SOCKET
179



GEAR RING
180 - 3 1/2"; 9 cm



STEERING WHEELS
185 - 1 1/2"; 4 1/2 cm
185a - 2 1/2"; 60 mm



DRIVING BANDS
light 186 - 2 1/2"; 6 cm
heavy 186c - 10"; 25 cm
186a - 6"; 15 cm
186d - 15"; 37 1/2 cm
186b - 10"; 25 cm
186e - 20"; 50 cm



ROAD WHEELS
187 - 2 1/2"; 60 mm
187b - 4 1/2"; 108 mm



CONICAL DISC
187a - 1 1/2"; 47 mm



SOCKET COUPLING
171



ANCHORING SPRING
176



FLEXIBLE COUPLING UNIT
175



FLEXIBLE PLATES
188 - 2 1/2" x 1 1/2"; 60 x 38 mm
189 - 5 1/2" x 1 1/2"; 140 x 38 mm
190 - 2 1/2" x 2 1/2"; 6 x 6 cm
190a - 3 1/2" x 2 1/2"; 9 x 6 cm
191 - 4 1/2" x 2 1/2"; 11 1/2 x 6 cm
192 - 5 1/2" x 2 1/2"; 14 x 6 cm
TRANSPARENT PLATES
193 - 2 1/2" x 1 1/2"; 60 x 38 mm
193a - 2 1/2" x 2 1/2"; 60 x 60 mm

BLUE PLASTIC PLATES
194 - 2 1/2" x 1 1/2"; 60 x 38 mm
194a - 2 1/2" x 2 1/2"; 60 x 60 mm
194b - 3 1/2" x 2 1/2"; 90 x 60 mm
194c - 4 1/2" x 2 1/2"; 115 x 60 mm
194d - 5 1/2" x 1 1/2"; 140 x 38 mm
194e - 5 1/2" x 2 1/2"; 140 x 60 mm

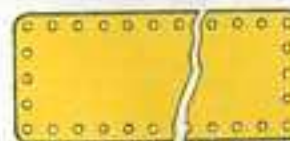

STRIP PLATES
195 - 7 1/2" x 2 1/2"; 19 x 6 cm
196 - 9 1/2" x 2 1/2"; 24 x 6 cm
197 - 12 1/2" x 2 1/2"; 32 x 6 cm

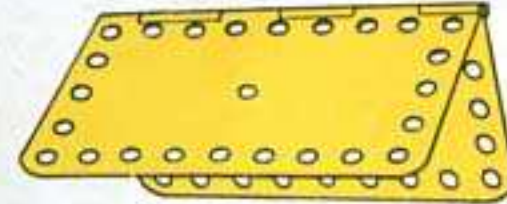

HINGED FLAT PLATE
198 - 4 1/2" x 2 1/2"; 11 1/2 x 6 cm



CURVED PLATE U SECTION
199 - 2 1/2" x 2 1/2" x 1/8"; 60 x 60 x 7 mm

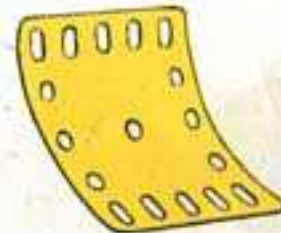

CURVED PLATE
200 - 2 1/2" x 2 1/2" x 1 1/8"; 60 x 60 x 43 mm

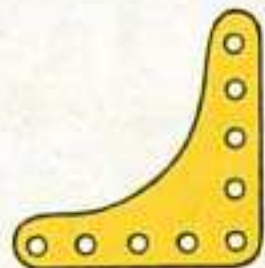

FLEXIBLE GUSSET PLATE
201 - 2 1/2" x 2 1/2"; 60 x 60 mm



HELICAL GEARS
211a - 1/2"; 12 mm
211b - 1/2"; 38 mm
can only be used together.



ROD AND STRIP CONNECTOR RIGHT ANGLE
212a

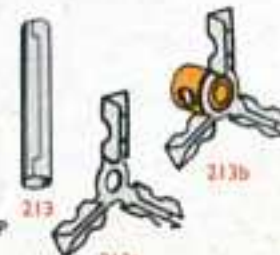

ROD CONNECTORS
213a



SEMI-CIRCULAR PLATE
214 - 2 1/2"; 6 cm

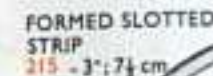

FORMED SLOTTED STRIP
215 - 3"; 7 1/2 cm



CYLINDER
216 - 2 1/2" x 1 1/2"; 60 x 30 mm

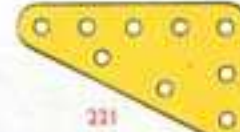

TRIANGULAR FLEXIBLE PLATES
221 - 2 1/2" x 1 1/2"; 60 x 38 mm
222 - 2 1/2" x 2"; 60 x 50 mm
223 - 2 1/2" x 2 1/2"; 60 x 60 mm
224 - 3 1/2" x 1 1/2"; 90 x 38 mm
225 - 3 1/2" x 2"; 90 x 50 mm
226 - 3 1/2" x 2 1/2"; 90 x 60 mm



KEY BOLT
231



ROD WITH KEYWAY
230 - 4"; 10 cm

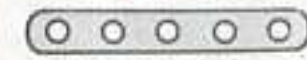

NARROW STRIPS
235 - 2 1/2" x 1/8"; 60 mm x 9 mm
235a - 3" x 1/8"; 75 mm x 9 mm
235b - 3 1/2" x 1/8"; 90 mm x 9 mm
235c - 4 1/2" x 1/8"; 115 mm x 9 mm
235f - 5 1/2" x 1/8"; 140 mm x 9 mm