

# **MECCANO**®

**BOOK OF MODELS**

**VOORBEELDENBOEK**

**LIVRE DES MODÈLES**

**LIBRO DEI MODELLI**

**MODELLBUCH**

**MODELLBOK**

**LIBRO DE MODELOS**

**LIVRO DE MODELOS**

**MODELLBOK**

**2/3/4**

Complete list of Meccano Parts  
 Komplete lijst van Meccano-onderdelen  
 Liste complète des pièces Meccano  
 Distinta delle componenti del Corredo Meccano  
 Vollständige Liste der Meccano-Teile  
 Fullständig förteckning över Meccanodelar  
 Lista completa de piezas de Meccano  
 Lista completa de peças do Meccano  
 Komplet list over Meccanodeler

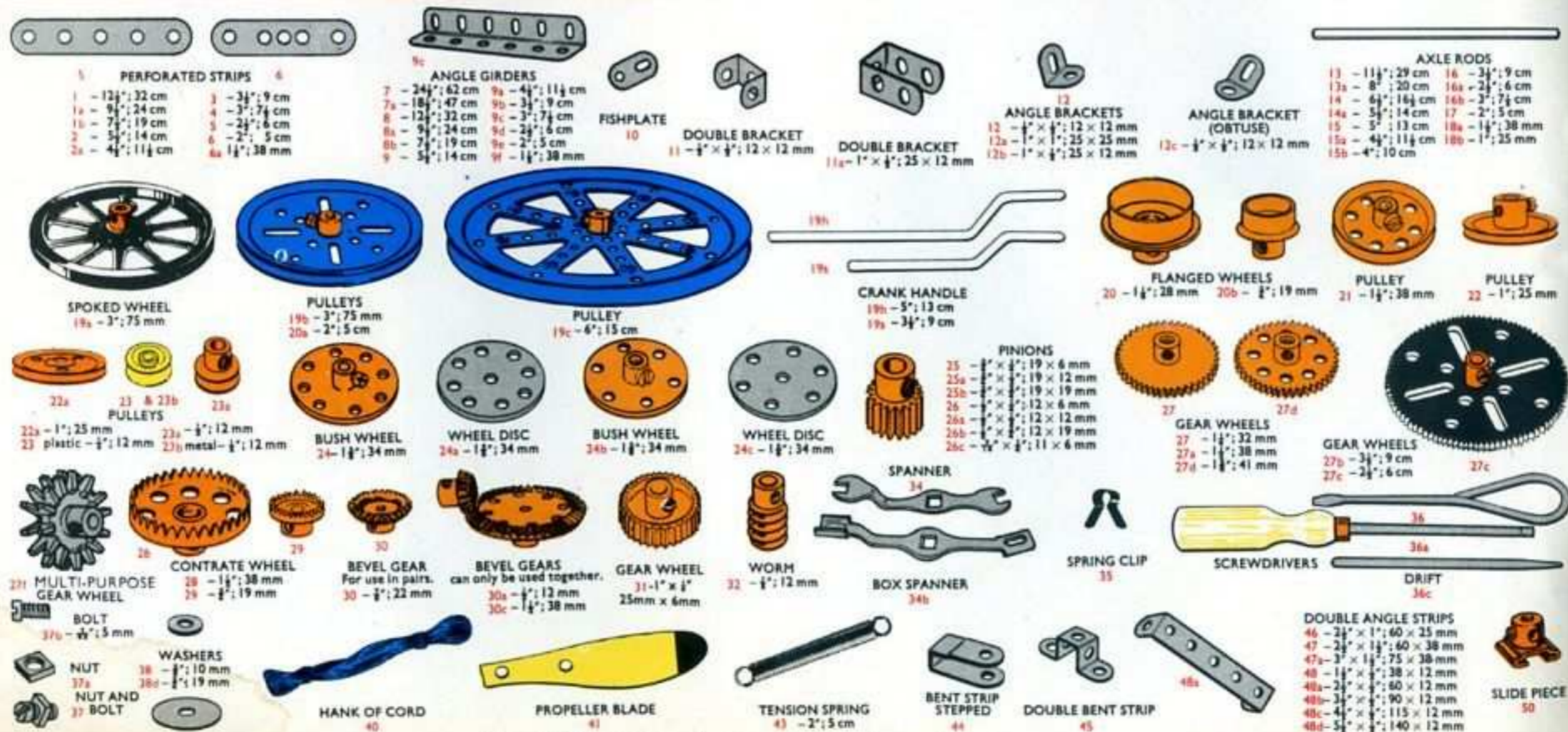

## How to use this Book Please read carefully

Contained in this Book are detailed plans for a selection of Meccano models, illustrated in full colour to make their assembly very easy to follow. In most cases, the Parts used in the models can be identified simply by looking at the illustrations; but where the identity of a Part may not be clear, its Part Number is printed in RED on the illustrations. You will be able to identify these numbered Parts by studying the individual pictures of the Parts printed on pages 2, 3 and 4 of the cover of this Book.

Some models are best constructed in separate units or 'sub-assemblies' and, in the plans, we have used thick red arrows, suitably numbered, to show the order in which these sub-assemblies should be built. The points at which the sub-assemblies are bolted together to form the complete model are indicated by red dots. Where red indicating lines pass behind a Plate or other Part, they are shown dotted.

Included on the plans are lists of Parts needed to build each sub-assembly, as well as a comprehensive list showing all the Parts required to build the whole model. In these lists, the Part Numbers are printed in RED and the quantity required in BLACK.

Some arrangements of Parts are used frequently in model-building and these we call Basic Meccano Constructions. You will find them illustrated on pages 4 to 7 of this Book and will see that each has an identifying Code Mark, i.e., BC1, BC2, etc. When one of these Code Marks appears on the illustrations, it indicates the principle of construction referred to by the same Code Mark in the pages of Basic Meccano Constructions.

Some of the models featured in this Book are fitted with a Meccano Motor and, in these models, the particular Motor used is indicated on the drawings by a special Code Mark. The following is a list of the Code Marks given to Meccano Motors, although all do not necessarily appear in this Book:

- M1—Meccano Magic Clockwork Motor.
- M2—Meccano No. 1 Clockwork Motor.
- M3—Meccano E15R Electric Motor.
- M4—Meccano Junior Power Drive Unit.
- M5—Meccano Power Drive Unit.

Please note that a Motor is included only in the 3M, 4M and 5ME Sets, although all Motors can be obtained separately through your Meccano dealer. The motorised models have been included for the benefit of those modellers who already possess a Motor, but the models themselves can still be built without a motor for hand operation. The Parts asterisked in the Parts Required lists for motorised models are not contained in the standard Sets but are packed with the Motor. You will find all the Power Units which have been specially designed for use with the Meccano system featured on page 21 of the No. 2 Book and page 53 of the No. 2, 3, 4 Book.

In addition to the Motors, special electronic components have been designed to increase the scope of the Meccano system. All these components are available in the form of an Electronic Accessory Set and examples of models containing the components have been included in the Manuals for Outfits 4 to 7. Please note, however, that the 5ME Set includes the Electronic Accessory Set.

Finally, please remember that the models we feature in our Instructions Manuals are only a few suggested examples of the infinite number of constructions that can be built with any Meccano Set. When you have built the models in this Book, why not try designing your own?

## Algemene aanwijzingen bij het gebruik van dit Boek Lees het Volgende aandachtig

Dit boek bevat gedetailleerde bouwplannen voor een aantal Meccano-modellen, afgebeeld in kleuren om het bouwen te vergemakkelijken. In de meeste gevallen kunnen de onderdelen die voor de modellen worden gebruikt op eenvoudige wijze geïdentificeerd worden door naar de afbeeldingen te kijken, maar indien de identiteit van een onderdeel niet duidelijk kan zijn, is het onderdeelnummer in ROOD afgedrukt op de afbeelding. Deze genummerde onderdelen kunnen dan geïdentificeerd worden met behulp van de aparte illustraties van de onderdelen op biz. 2, 3 en 4 en op de omslag van dit boek.

Enkele modellen kunnen het beste gebouwd worden door eerst aparte onderdeelgroepen samen te stellen en in de bouwplannen is met dikke rode pijlen, voorzien van een nummer, aangegeven in welke volgorde deze onderdeelgroepen moeten worden gebouwd. De punten waar deze onderdeelgroepen aan elkaar vast gezet worden om een compleet model te vormen zijn aangegeven met rode punten. Rode merklijnen die achter een plaat of ander onderdeel langslopen zijn aangegeven met stippellijnen.

De bouwplannen bevatten tevens onderdelenlijsten met onderdelen die nodig zijn om elke onderdelengroep samen te stellen, zowel als een uitgebreide lijst met alle onderdelen voor het bouwen van een compleet model. In deze lijsten zijn de onderdeelnummers gedrukt in rood en het aantal benodigde onderdelen in zwart.

Enkele groepen onderdelen moeten geregeld gebruikt worden bij het bouwen van modellen, en deze noemen we Basis Meccano Constructies. Ze zijn afgebeeld op biz. 4 tot 7 van dit boek en elke groep is voorzien van een code, zoals bijvoorbeeld BC1, BC2, enz. Indien één van deze code-nummers aangegeven is in een afbeelding, geeft dit aan dat de bouwwijze dezelfde is als vermeld in de Basis Meccano Constructies.

Enkele modellen die in dit boekje worden beschreven zijn voorzien van een Meccano motor en bij deze modellen is het type motor in de tekeningen aangegeven met een speciaal codemerkteken. Hieronder zijn de codemerktekens voor Meccano motoren vermeld; alle motoren komen echter niet noodzakelijk in dit boek voor.

- M1—Meccano Magic Clockwork Motor (Veermotor)
- M2—Meccano no. 1 Clockwork Motor (Veermotor)
- M3—Meccano E15R Electric Motor (Elektrische motor)
- M4—Meccano Junior Power Drive Unit (Junior drijfwerkuitrusting)
- M5—Meccano Power Drive Unit (Drijfwerkuitrusting)

Alleen de sets 3M, 4M en 5ME bevatten een motor, maar alle motoren zijn apart verkrijgbaar bij de Meccano-handelaar. De modellen met een motor zijn bedoeld voor hen een motor bezitten, maar de modellen kunnen ook gebouwd worden zonder motor en met de hand worden bediend. De onderdelen voorzien van een sterretje (\*) in de onderdelenlijst voor modellen voorzien van een motor, zijn niet aanwezig in de standaard sets, maar zijn verpakt met de motor. Alle motoren die speciaal ontworpen zijn voor het Meccano systeem zijn afgebeeld op biz. 21 van boek nr. 2 en op bladzijde 53 van boek nr. 2, 3, 4.

Behalve de motoren zijn speciale elektronische onderdelen ontworpen om het Meccano systeem veelzijdiger te maken. Al deze delen zijn verkrijgbaar in de vorm van een Elektronische uitbreidingsset en voorbeelden van de modellen zijn vermeld in de handleidingen voor de bouwdozen 4 t/m 7. Set 5ME bevat elektronische uitbreidingsset.

Tenslotte wijzen wij erop dat de modellen afgebeeld in onze handleidingen slechts enkele voorbeelden zijn uit de oneindige reeks constructies die gemaakt kunnen worden met elke Meccano-set. Na het bouwen van de modellen in dit boek, kun je proberen je eigen ontwerpen te maken.

## Comment utiliser ce Livre A lire avec le plus grand soin

Ce livre contient des plans détaillés d'une sélection de modèles Meccano, ceux-ci sont illustrés en couleurs, afin d'en faciliter le montage. Dans la plupart des cas, il suffit de se référer aux illustrations pour identifier simplement les pièces utilisées dans les modèles. Cependant lorsque vous trouverez certaines difficultés dans ce domaine, vous verrez que les numéros de série de la pièce en question se trouvent imprimés en rouge sur les illustrations. Il vous suffira de jeter un coup d'oeil aux illustrations figurant aux pages 2, 3 et 4 de ce livre pour pouvoir procéder à une identification facile de ces pièces numérotées.

Parfois, il vaut mieux assembler certains modèles en sous-ensembles séparés et, sur les plans, nous avons indiqué au moyen de flèches rouges l'ordre dans lequel ces sous-ensembles devraient être montés. Les endroits auxquels ces parties sont boulonnées les unes aux autres pour former le modèle intégral sont indiqués par des points rouges. Toute ligne rouge passant derrière une pièce est représentée en pointillé.

Les plans contiennent une liste de pièces nécessaires à la construction de chaque section séparée, ainsi qu'une liste complète dans laquelle figure toutes les pièces indispensables à la construction du modèle entier. Dans ces listes, le numéro de la pièce est indiqué en rouge et le nombre de pièces requises en noir.

Certains assemblages de pièces fréquemment utilisés dans la construction de modèles sont désignés sous l'appellation 'construction de base'. Ceux-ci sont illustrés aux pages 4 à 7 de ce livre, et vous remarquerez que chacun possède un code d'identification spécial = BC1, BC2, etc.

Lorsqu'un de ces codes figure sur les illustrations, sa présence fait référence au montage identifié par le même code dans les pages des 'Constructions de Base'.

Certains des modèles exposés dans ce livre sont équipés d'un moteur Meccano et, chez ceux-ci, le type de Moteur utilisé est indiqué sur le dessin par l'intermédiaire d'un code spécial. Vous allez trouver ci-dessous une liste de leurs codes d'identification, bien que la totalité d'entre eux n'apparaissent pas dans ce livre.

- M1—Moteur à ressort 'Magique'
- M2—Moteur à ressort '1'
- M3—Moteur électrique E15R
- M4—Junior Power Drive Unit
- M5—Power Drive Unit

Vous pourrez constater que seuls les jeux 3M, 4M et 5ME disposent d'un moteur. Il convient cependant de préciser que tous les types de moteurs peuvent être achetés séparément chez votre distributeur 'Meccano'. Les modèles motorisés ont été inclus à l'intention des adeptes qui possèdent déjà un moteur, mais il n'en reste pas moins que ces mêmes modèles peuvent être construits en vue d'être actionnés à la main. Les pièces marquées d'un astérisque ne sont pas comprises dans les boîtes, elles sont au contraire, expédiées séparément avec le moteur. Tous les systèmes moteurs spécialement conçus pour équiper la série Meccano figurent à la page 21 du livre 2 et à la page 53 du livre 2, 3, 4.

En plus des moteurs, des composants électroniques spéciaux ont été mis au point de façon à accroître le potentiel du système Meccano.

Tous ces éléments font partie d'un jeu d'accessoires électroniques, et des exemples de modèles utilisant ces composants ont été inclus dans le Manuel se rapportant aux ensembles 4 à 7.

Veillez cependant remarquer que la boîte 5ME comprend cet équipement à l'origine.

Finalement, n'oubliez pas que les modèles figurant dans nos Manuels ne constituent que quelques exemples de l'immense variété qui peut être réalisée avec chaque boîte. Lorsque vous aurez construit les modèles illustrés dans ce livre, pourquoi n'essayeriez-vous pas d'en créer d'autres vous-même.

## Guida alla costruzione dei modelli Prima di cominciare la costruzione pregasi leggere attentamente

In questo Manuale è illustrata una scelta di modelli Meccano basati su disegni particolareggiati a colori che rendono le costruzioni estremamente facili. Quasi sempre, i Pezzi che costituiscono i modelli possono essere identificati guardando semplicemente le illustrazioni, ma quando l'identificazione di un Pezzo non è ben chiara, il rispettivo Numero di Catalogo è stampato in ROSSO sui piani di costruzione. Osservando i Pezzi illustrati alle pagine 2, 3 e 4 di copertina di questo Manuale, a poco a poco Vi sarà facile identificarli.

Certi modelli è consigliabile costruirli a sezioni separate e, nei piani di costruzione, per mostrare l'ordine nel quale queste sezioni devono essere realizzate, le stesse sono indicate con evidenti per mezzo di frecce rosse convenientemente numerate. Le posizioni nelle quali le sezioni devono essere avvitate insieme per formare il modello completo sono indicate con puntini rossi; dove una linea rossa attraversa una Piastra o altro Pezzo, essa è tratteggiata.

I piani di costruzione comprendono le liste dei Pezzi occorrenti per costruire ciascuna sezione di modello e anche una lista complessiva che indica tutti i Pezzi occorrenti per costruire il modello completo. In queste liste i Numeri di Catalogo dei Pezzi sono stampati in ROSSO e le quantità occorrenti in NERO.

Certe combinazioni di Pezzi che vengono impiegate frequentemente nella tecnica costruttiva dei modelli sono denominate "Costruzioni di Base Meccano" e sono illustrate dalla pagina 4 alla pagina 7 di questo Manuale e ciascuna di esse ha una Sigla di riferimento: BC1, BC2 ecc. Quando una di queste Sigle è indicata sulle illustrazioni dei modelli vuol dire che per costruire quella parte di modello occorre la combinazione di Pezzi che è contraddistinta dalla stessa Sigla nelle pagine delle "Costruzioni di Base Meccano".

Vari modelli fra quelli illustrati in questo Manuale sono muniti di un Motorino Meccano e sulle illustrazioni di tali modelli il tipo di Motorino utilizzato è indicato da una speciale Sigla. Le Sigle che contraddistinguono i vari tipi di Motorini Meccano e che non appaiono tutte in questo Manuale, sono le seguenti:

- M1—Motorino a Molla Meccano Magic
- M2—Motorino a Molla Meccano No. 1
- M3—Motorino Elettrico Meccano E15R
- M4—Motorino Elettrico Meccano Junior
- M5—Motorino Elettrico con Cambio a 6 Velocità

E' da notare che nelle Scatole 3M, 4M e 5ME è compreso solamente un Motorino Meccano, ma tutti i Motorini Meccano possono essere acquistati separatamente presso i negozi rivenditori Meccano. Le illustrazioni dei modelli motorizzati facilitano quei costruttori che già posseggono un Motorino Meccano, fornendo esempi di pratica applicazione, ma gli stessi modelli possono essere anche costruiti senza Motorino per funzionamento a mano. Nelle liste di quantità dei Pezzi occorrenti per i modelli motorizzati, degli asterischi contraddistinguono i Pezzi che non sono contenuti nella Scatola Meccano: tali Pezzi vengono forniti unitamente al Motorino. Tutti i Motorini Meccano sono stati particolarmente studiati per l'impiego nel Sistema Meccano e sono illustrati a pagina 21 del manuale 2 e alla pagina 53 del manuale 2/3/4.

Oltre ai Motorini sono state ideate speciali Parti Elettroniche per accrescere sempre più l'interesse e le infinite possibilità del Sistema Meccano. Queste Parti Elettroniche costituiscono una Serie Elettronica ed esempi di modelli comprendenti questi elementi sono stati inclusi nei Manuali d'Istruzioni delle Scatole dal No. 4 al No. 7. La Serie di Parti Elettroniche è già inclusa nel corredo della Scatola 5ME.

I modelli illustrati nei Manuali d'Istruzioni sono solamente pochi esempi dell'infinito numero di costruzioni che possono essere realizzate con le autentiche Scatole Meccano originali. Quando avrete costruito i modelli illustrati in questo Manuale il più grande divertimento e la maggior soddisfazione li otterrete creando altri modelli di vostra invenzione.

## Verwendung dieses Buches Bitte sorgfältig durchlesen

In diesem Buch befinden sich ausführliche Pläne in Farbe für eine Reihe von Meccano-Modellen, um den Bau der Konstruktion so einfach wie möglich zu gestalten. In den meisten Fällen sind die nötigen Einzelteile leicht auf der Abbildung zu erkennen; darüberhinaus ist die Bauteilnummer in rot auf der Abbildung zu sehen, sollte einmal etwas unklar sein. Diese nummerierten Teile sind leicht auffindbar, wenn man sich die einzelnen Abbildungen der Bauteile auf den Seiten 2, 3 und 4 dieses Buchumschlages ansieht.

Einige Modelle werden am besten in getrennten Einheiten oder 'Baugruppen' konstruiert; die Pläne wurden daher mit dicken roten Pfeilen gekennzeichnet, die nummeriert sind, um aufzuzeigen, in welcher Reihenfolge die Baugruppen zusammengestellt werden sollen. Die roten Punkte dagegen machen deutlich, an welchen Punkten die Baugruppen zusammengeschraubt werden, um das vollständige Modell zu ergeben. Wo die roten Hilfslinien hinter einer Platte oder einem anderen Teil verlaufen, sind sie in gestrichelter Form dargestellt.

Die Pläne enthalten weiterhin Einzelteillisten, die zum Bau jeder einzelnen Gruppe benötigt werden; ausserdem ist eine vollständige Liste aller für das ganze Modell benötigten Teile aufgeführt. Die roten Ziffern in diesen Listen kennzeichnen die Bauteilnummer, während die schwarzen Zahlen die Anzahl der benötigten Bauteile darstellen.

Einige Bauanordnungen werden beim Bau von Modellen sehr häufig verwendet; sie werden Meccano-Grundkonstruktionen genannt. Sie sind auf den Seiten 4 bis 7 dieses Buches abgebildet und mit einer Kennzahl wie BC1, BC2 usw. versehen. Wenn eine dieser Kennzahlen auf den Abbildungen zu sehen ist, so weist sie auf das verwendete Konstruktionsprinzip hin, wie es in den Meccano-Grundkonstruktionen aufgeführt ist.

Einige Modelle in diesem Buch sind mit einem Meccano-Motor ausgestattet; der für diese Modelle verwendete Motor wird durch eine besondere Kennzahl angegeben. Die im folgenden aufgeführten Motoren mit den entsprechenden Kennzahlen werden nicht unbedingt an Modellen in diesem Buch verwendet:

- M1—Meccano magischer Uhrwerkmotor
- M2—Meccano Nr. 1 Uhrwerkmotor
- M3—Meccano E15R Elektromotor
- M4—Meccano Junior-Antriebseinheit
- M5—Meccano Antriebseinheit

Es ist zu beachten, dass nur die Sätze 3M, 4M und 5ME über Motoren verfügen. Motoren sind jedoch einzeln bei jedem Meccano-Händler erhältlich. Die betriebenen Modelle wurden miteinbezogen, da sicher viele Modellbauer bereits einen Motor besitzen; die Modelle können natürlich auch ohne Motor konstruiert und dann mit der Hand betrieben werden. Die mit einem Sternchen versehenen Teile, die in der Liste der benötigten Bauteile für motorisierte Modelle aufgeführt sind, gehören nicht zum Standard-Bausatz, sondern werden zusammen mit dem Motor geliefert. Alle Antriebseinheiten, die speziell zur Verwendung im Meccano-System entwickelt wurden, sind auf Seite 21 des Heftes Nr. 2 und auf Seite 53 des Heftes Nr. 2/3/4 zu finden.

Zusätzlich zu den Motoren wurden weiterhin spezielle Elektronikbauteile geschaffen, die die Anwendungsbereiche des Meccano-Systems noch erweitern. Alle diese Komponenten sind in Form eines Elektronikbauteilekastens erhältlich; Konstruktionsbeispiele unter Verwendung dieser Bauteile wurden in den Handbüchern für die Sätze 4 bis 7 miteinbezogen. Wir möchten jedoch darauf hinweisen, dass Satz 5ME den Elektronikbauteilekasten enthält.

Man darf natürlich nicht vergessen, dass die in den Handbüchern abgebildeten Modelle lediglich Beispiele einer unendlichen Vielzahl von Konstruktionsmöglichkeiten sind, die mit Hilfe der Meccano-Baukästen geschaffen werden können. Denn wenn man alle aufgeführten Beispiele konstruiert hat, warum sollte man nicht damit beginnen, eigene Konstruktionen zu entwerfen!

## Hur man använder denna Bok Läs igenom noga

Denna bok innehåller detaljerade planer över ett urval Meccanomodeller, vilka avbildats helt i färg för att göra monteringen lätt att följa. I de flesta fall kan de till modellerna använda delarna identifieras enkelt och lätt genom en blick på illustrationerna, men i de fall där delens identitet kanske inte är klar, har dess delnummer angivits i RÖTT på illustrationen. Det går att identifiera dessa nummer genom att studera de individuella bilderna av delarna på sidorna 2, 3 och 4 av omslaget till denna bok.

En del modeller konstrueras bäst i skilda enheter, och i planerna har vi använt oss av tjocka, röda pilar med lämplig numrering för att visa den ordning, i vilken dessa enheter bör byggas. De ställen där enheterna skruvas samman till en komplett modell anges med röda prickar. Där röda linjer passerar bakom en plåt eller någon annan del återges de i prickat utförande. I forening med planerna ingår förteckningar över de delar som behövs för att bygga varje enhet såväl som en allsidig förteckning över alla för modellens byggnad erforderliga delar. I dessa förteckningar är delarnas nummer angivna i RÖTT och delarnas antal i SVART.

Vissa hopsättningsarrangemang kommer ofta till användning vid modellbygge, och dem kallar vi grundkonstruktioner. De avbildas på sidorna 4 till 7 i denna bok, och det framgår att de har sina egna identifierande beteckningar, d.v.s. BC1, BC2 o.s.v. När en av dessa beteckningar uppträder i en illustration, anger den principen för den konstruktion, som representeras av samma beteckning på sidorna för grundkonstruktioner.

En del av modellerna i denna bok är utrustade med en Meccanomotor, och den motor som används för dessa modeller anges i ritningarna med en speciell beteckning. Nedan följer en förteckning över Meccanomotorernas beteckningar, även om alla inte nödvändigtvis omnämns i denna bok.

- M1—Meccano Magic urverksmotor
- M2—Meccano nr 1 urverksmotor
- M3—Meccano E15R elmotor
- M4—Meccano Junior drivaggregat
- M5—Meccano drivaggregat

Lägg märke till att en motor ingår endast i satserna 3M, 4M och 5ME, även om alla motorer kan erhållas separat från Meccanooffären. De motordrivna modellerna har medtagits för de modellbyggare, som redan äger en motor, men modellerna själva kan naturligtvis byggas utan motor för manuell drift. De med en asterisk markerade delarna i förteckningarna över erforderliga delar till motordrivna modeller ingår inte i standard-satserna utan medföljer motorn. På sidan 21 i bok 2 och på sidan 53 i bok 2/3/4 återfinns alla de drivaggregat, som specialkonstruerats för användning med Meccanosystemet.

Utöver motorerna har elektroniska specialdetaljer konstruerats för att öka Meccanos användningsområde. Alla dessa detaljer kan erhållas i form av en elektronikbihängsatsen, och exempel på modeller, i vilka dessa delar ingår, har medtagits i handböckerna för uppsättningarna 4-7. Observera emellertid, att elektronikbihängsatsen ingår i sats 5ME.

Kom slutligen ihåg, att de modeller vi visar i våra handböcker endast är några få exempel på de oändligt många konstruktioner, som kan byggas med en Meccanosats. Den som först byggt alla modellerna i denna bok kan sedan försöka konstruera sina egna!

## Léanse detenidamente las siguientes Indicaciones sobre el uso de este libro

El presente libro contiene planos detallados para una selección de modelos Meccano, con ilustraciones a todo color que simplifican el procedimiento de montaje. En la mayoría de los casos bastará consultar las ilustraciones para ver las piezas que se necesitan, pero si la identificación de alguna de éstas ofrece dificultad, no tiene más que confrontar su número de referencia, marcado en ROJO en el plano, con los grabados de las piezas individuales que aparecen las caras 2a., 3a. y 4a. de la cubierta de este libro.

Para algunos modelos resulta más fácil construir primero los módulos individuales o "subconjuntos", cuyo orden de montaje hemos hecho constar en los planos mediante gruesas flechas convenientemente numeradas, señalando con puntos rojos los lugares en donde se deben atornillar estos subconjuntos para formar el modelo completo. La líneas indicadoras que pasan por detrás de una chapa u otro elemento se hallan representadas por puntos.

Los planos contienen relaciones de las Piezas que se necesitan para formar cada subconjunto, así como relación de todas las Piezas necesarias para componer el modelo. En dichas listas, los números de pieza van señalados en ROJO y la cantidad que de cada una se necesita, en NEGRO.

Algunas combinaciones de piezas vienen utilizándose frecuentemente en la construcción de modelos, habiéndoseles denominado Construcciones Meccano Básicas. Estas van ilustradas en las páginas 4 a 7 del presente libro; cada una acompañada de su clave de identidad, es decir BC1, BC2, etc. Al encontrarse con una de dichas claves en los planos, el principio de construcción a seguir es el que figura frente a la misma en las páginas de Construcciones Meccano Básicas. Varios de los modelos reproducidos en este libro van impulsados por un Motor Meccano, indicándose en los planos la clave del motor a emplear en cada caso. A continuación damos una lista de las claves correspondientes a Motores Meccano, si bien no todos ellos figuran necesariamente en este libro:

- M1—Motor de cuerda Meccano Magic
- M2—Motor de cuerda Meccano No. 1
- M3—Electromotor Meccano E15R
- M4—Unidad motriz Meccano Junior Power
- M5—Unidad motriz Meccano Power

Los Juegos 3M, 4M y SME son los únicos que van equipados con motor. No obstante, se podrán obtener todos los motores por separado dirigiéndose al almacenista Meccano. Se han incluido los modelos motorizados para los modelistas que ya disponen de motor, aunque ello no impide construir los modelos sin motor y accionarlos a mano. Los elementos destacados con un asterisco en la Lista de Piezas Necesarias para modelos motorizados no figuran en los Juegos standard, sino que se suministran junto con el Motor. Todas las Unidades Motrices especialmente concebidas para su uso con el Meccano se hallan representadas en la página 21 de libro 2 y en la página 53 de libro 2/3/4.

Además de los Motores, se han realizado elementos electrónicos especiales a fin de ampliar las posibilidades del Meccano, reuniéndose todos estos elementos para formar un Equipo de Accesorios Electrónicos. En los Manuales correspondientes a los Juegos 4 a 7 se dan algunos ejemplos de modelos que integran estos elementos, debiendo precisarse que el Juego SME lleva ya incorporado el Equipo de Accesorios Electrónicos.

Por último, recuerde que las construcciones reproducidas en nuestros Manuales no son más que unos pocos ejemplos de la infinidad de modelos realizables con cualquier juego de Meccano. Una vez haya construido todos los que figuran en este libro, ¿por qué no intenta construir alguno que sea fruto de su propio ingenio?

## Como utilizar este Livro Pedimos que a sua leitura seja feita com atenção

Neste livro estão indicados planos pormenorizados que habilitam a seleção dos modelos Meccano ilustrados a cores cheias para facilitar o seguimento da montagem. Na maioria dos casos, as Peças usadas nos modelos podem ser identificadas se se olhar para as ilustrações, mas sempre que seja difícil identificar uma peça, deve-se ver o Número de Peça impresso em ENCARNADO nas ilustrações. Será capaz de identificar estas peças numeradas observando as figuras individuais das Peças impressas nas páginas 2, 3 e 4 da capa deste Livro.

Alguns modelos são melhor construídos em unidades separadas ou "subconjuntos", e nos planos, usamos setas grossas a encarnado, devidamente numeradas, para indicar a ordem na qual estes sub-conjuntos devem ser construídos. Os pontos nos quais os sub-conjuntos são fixos uns aos outros pelos parafusos para formarem o modelo completo são indicados pelos pontos encarnados. Sempre que as linhas indicadoras a encarnado o pasam por trás de uma chapa ou outra Peça, são apresentadas a tracejado.

Nos planos estão indicadas as Peças necessárias para se construírem os sub-conjuntos, assim como uma lista de todas as Peças necessárias a construção total do modelo. Nestas listas, os números de Peças estão impressos a encarnado e a quantidade necessária a PRETO.

Alguns arranjos de Peças são usados frequentemente na construção de modelos, e a estes chamamos Construções Básicas do Meccano. Estão ilustrados nas páginas 4 a 7 deste Livro e observará que cada um deles tem uma Marca de Código que os identifica facilmente, como por exemplo BC1, BC2 etc. Sempre que uma destas Marcas aparece nas ilustrações, indica o mesmo princípio de construção que é apresentado nas páginas referentes às Construções Básicas do Meccano.

Alguns dos modelos apresentados neste Livro são montados com um Motor Meccano e, nestes modelos, o motor que é usado é indicado no desenho por uma marca de Código especial. Seguidamente apresentamos uma lista de Marcas de Código dadas aos Motores Meccano, embora nem todos apareçam forçosamente neste Livro:

- M1—Motor de Corda Mágico Meccano
- M2—Motor de Corda No. 1 Meccano
- M3—Motor Eléctrico E15R Meccano
- M4—Unidade de Accionamento Junior Meccano
- M5—Unidade de Accionamento Meccano

Pedimos o favor que note que só é incluído um motor nos Jogos 3M, 4M, e SME, embora todos os motores possam ser comprados separadamente através da casa vendedora dos jogos Meccano. Os modelos motorizados foram incluídos tendo em vista todos os que já possuem um motor, mas os modelos podem ser construídos sem motor para funcionamento manual. As Peças com asterisco nas Listas de Peças dos modelos motorizados não são incluídas nos Jogos Normais mas sim com o motor. Na página 21 de Livro 2 e na página 53 de Livro 2/3/4, encontrará todas as Unidades Motrizes que foram desenhadas especialmente para serem usadas no sistema Meccano.

Além dos Motores, foram também desenhados componentes electrónicos especiais para alargar a esfera de acção do sistema Meccano. Todos estes componentes se encontram à venda sob a forma de um Jogo de Accesorios Electrónicos e incluíram-se nos Manuais para os Jogos 4 a 7 exemplos de modelos que contêm estes componentes. É favor notar contudo que o Jogo SME inclui o Jogo de Accesorios Electrónicos.

Por fim, resta-nos fazer recordar que os modelos que apresentamos nos nossos Manuais de Instruções representam somente alguns exemplos do número infinito de construções que podem ser feitas com um Jogo Meccano. Quando já tiver construído todos os modelos apresentados neste Livro, porque não se aventura a desenhar e construir os modelos da sua invenção?

## Hvorledes denne boken Brukes Les dette omhyggelig

I denne boken står det oppgitt detaljerte skisser for valg av Meccano modeller, illustrert i farver slik at sammensetningen er meget lett å følge. I de fleste tilfelle kan delene som inngår i modellene finnes ved bare å se på illustrasjonene, men hvor det kanskje ikke er så helt klart å finne frem til delen står delnummeret trykt med RØDT på illustrasjonen. Ved å se nærmere på de individuelle bildene av delene som finnes på sidene 2, 3 og 4 på omslaget av denne boken, kan man finne frem til numrene.

Enkelte modeller bygges lettest opp ved at dette skjer i atskilte enheter, eller "underenheter", og vi har brukt tykke, rød piler i planene for å angi rekkefølgen disse underenhetene bør bygges i. Pilene er nummererte. Røde punkter angir de steder hvor disse underenhetene settes sammen for å danne den fullstendige modellen. Hvor røde indikasjonlinjer går bak en plate eller andre deler, er disse angitt som en rekke punkter.

Tegningene inneholder liste over de delene som trenges til å bygge hver underenhet, såvel som en omfattende liste som angir alle delene som behøves for å bygge hele modellen. I disse listene er delnumrene trykt med RØDT, og mengden som skal til, med SORT.

En del arrangementer av deler benyttes ganske ofte ved oppbyggingen av modeller, og vi kaller disse for grunndeler. Disse står avbildet på sidene 4 til 7 i denne boken, og hver og en av disse har en kode slik at de er lette å gjenkjenne, f.eks. BC1, BC2 osv. Når ett av disse kodemerkene dukker opp på illustrasjonene betyr det at oppbyggingens prinsipp er det samme som det som angies av den samme koden på sidene som omhandler Basic Meccano Construction (Meccano grunndeler).

Noen av de modellene som står i denne boken har en Meccano Motor, og den spesielle motoren som brukes i disse modellene står angitt på tegningen med et kodemerke. Følgende er en liste over disse kodene som er satt på Meccano motorene, skjønt de behøver ikke nødvendigvis alle å stå i denne boken:

- M1—Meccano Magic Clockwork Motor
- M2—Meccano Nr. 1 Clockwork Motor
- M3—Meccano E15R Elektrisk motor
- M4—Meccano Junior Power Drive enhet
- M5—Meccano Power Drive enhet

Legg merke til at en motor er inkludert kun i Settene 3M, 4M og SME, skjønt alle motorer kan fåes separat fra alle Meccano forhandlere. De motoriserte modellene er blitt tatt med slik at de som allerede har en motor kan glede seg over dem, men selve modellene kan fremdeles bygges uten en motor, og drives med håndkraft. Delene som er merket med\* i listen over deler som er nødvendige for motoriserte modeller, finnes ikke i standardsettene, men der er pakket sammen med motoren. Alle de Power Units (kraftenhetene) som er spesielt beregnet på å brukes sammen med Meccanosystemet finnes omtalt på side 21 i bok 2 og på side 53 i bok 2/3/4.

I tillegg til motorene er spesielle elektroniske deler blitt laget for å utvide mulighetene til Meccanosystemet. Alle disse delene kan fåes i form av et elektronisk reservsett, og eksempler på modeller som inneholder delene er inkludert i håndboken for utstyr 4 til 7. NB: SME sett inkluderer det elektroniske reservsett.

Og endelig—husk at de modellene vi omtaler i våre bøker bare er noen få eksempler på det uendelige antall modeller som kan bygges med et hvilket som helst Meccanosett. Når modellene i denne boken er blitt bygget, hvorfor ikke forsøke å lage noen selv?

**BC1** is a method of joining two Strips together so that they can move in relation to each other. It is known as 'lock-nutting' and makes use of two Nuts tightened together on the Bolt. The Nuts must not grip the Strips tightly.

**BC2** is another method of 'lock-nutting'. Two Nuts, one above and one below Strip a, are tightened against it by turning them as indicated.

**BC3** is two Strips joined end-to-end by a Strip b.

**BC4** is two Strips joined together by two Bolts and Nuts.

**BC5** is an Obtuse Angle Bracket (12c) used to join two Strips at an angle to each other.

**BC6** is a bearing for a Rod made from a Double Bent Strip (45) bolted to a Plate. The Rod is pushed through the Double Bent Strip and Plate, fitted with a Washer, and held in place by a Spring Clip (35).

**BC7** is a 1" x 1/2" Double Bracket (11a) used to provide an extended bearing for a Rod.

**BC1** is een systeem om twee stroken onderdelen te verbinden en wel zo, dat zij ten opzichte van elkaar vrij kunnen draaien en/of bewegen. Het is een bout met twee moeren. De bovenste moer noemt men een „borgmoer“.

**BC2** is een andere methode om een zgn. „borgmoer“ te maken. Twee moeren, één boven en één onder strook a, worden vast tegen de strook a gedraaid.

**BC3** is het verbinden van 2 stroken d.m.v. de derde, kortere strook b.

**BC4** is twee stroken aan elkaar verbonden met twee bouten en moeren.

**BC5** is een stompe hoeksteun (12c) gebruikt om twee strook-einden in een hoek met elkaar te verbinden.

**BC6** is een stevig lager of steun voor een draaiende as; gemaakt van een dubbelgebogen strook (45) welke op een plaat is geschroefd. De as is door de dubbelgebogen strook en de plaat gestoken. Aan de bovenkant, onder de riemschijf is een onderlegging aangebracht. Een veerclip (35) wordt aan de onderzijde gebruikt om de as op zijn plaats te houden.

**BC7** is een dubbel-steunstuk (11a) geschroefd aan een plaat of ander onderdeel vormt ook een goede steun of lagering voor een as.

**BC1** est un assemblage qui permet à deux bandes de pivoter ou de bouger l'une par rapport à l'autre. Ce système s'appelle "articulation à contre-écrou" et nécessite deux écrous sur le même boulon. Les écrous ne doivent pas bloquer les bandes.

**BC2** est un autre système d'articulation à contre-écrou, mais ici on place un écrou au-dessus et un au-dessous de la bande "a" et on les serre contre cette bande en les tournant comme indiqué par les flèches.

**BC3** montre comment on maintient deux bandes bout à bout grâce à une bande plus courte "b".

**BC4** présente l'assemblage de deux bandes par deux écrous et deux boulons.

**BC5** Une équerre à 135° (12c) relie deux bandes placées bout à bout.

**BC6** fournit un robuste palier d'extrémité pour un axe. Il suffit d'un cavalier (45) boulonné sur une plaque. Le tringle passe dans le cavalier, puis dans la plaque. Elle est maintenue sous la plaque par une rondelle et une clavette (35).

**BC7** montre comment on construit un palier simple pour un axe avec un support double de 12 x 25 mm.

**BC1** è il modo di congiungere due strisce permettendone l'articolazione. Si ottiene applicando due dadi sulla vite di congiunzione. I dadi non devono premere contro le strisce. Questo sistema in meccanica è chiamato "contro-dado".

**BC2** è un'altra applicazione del "contro-dado": i due dadi, uno sopra e l'altro sotto la striscia "a" sono avvitati come indicano le frecce.

**BC3** è la congiunzione di due strisce alla loro estremità per mezzo di un'altra striscia "b".

**BC4** è il modo di unire due strisce con due viti e relativi dadi.

**BC5** è un supporto ad angolo ottuso (12c) usato per congiungere due strisce alle estremità ad angolo fra loro.

**BC6** è un solido supporto per un asse di rotazione. Si costruisce con un supporto a cavaliere (45) avvitato ad una piastra. L'asse attraversa il supporto a cavaliere e la piastra ed è tenuto in posizione al di sotto da una rondella (38) e da un fermaglio a molla (35).

**BC7** è un supporto doppio di mm. 25 x 12 (11a) fissato ad una piastra o altro pezzo per ottenere un supporto per un asse.

**BC1** zeigt, wie man zwei Bänder so verbindet, dass sie gegen einander verdreht oder bewegt werden können. Man nennt diese Konstruktion "Gegenmutter-Arretierung". Man dreht dazu zwei Muttern auf die Halteschraube. Die Muttern dürfen die Bänder nicht stark festhalten.

**BC2** ist eine zweite Art der Gegenmutter-Arretierung. Dazu werden zwei Muttern, eine über, eine unter dem Band "a" in Gegenrichtung angezogen, wie es die Pfeile zeigen.

**BC3** ist die Verbindung zweier Bänder durch ein kürzeres Band "b".



**BC1**



**BC2**

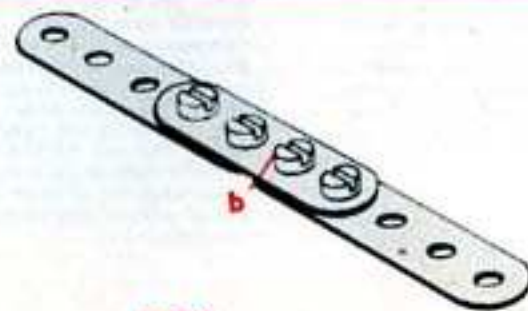

**BC3**

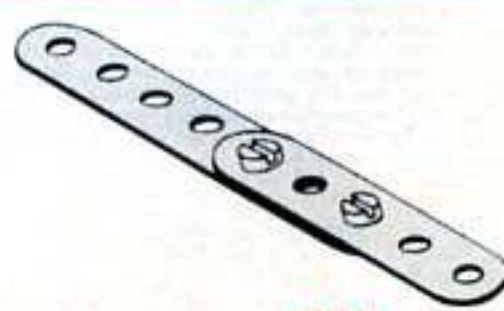

**BC4**

BC4 ist die Verbindung zweier Bänder durch zwei Schrauben und Muttern.

BC5 ist eine stumpfe Winkelstütze (12c), die dazu dient, zwei Bänder an ihren Enden in einem Winkel zu verbinden.

BC6 ist eine feste Halterung oder Lagerung für eine Achse. Man schraubt ein doppelt gebogenes Band (45) auf eine Platte. Die Achse steckt man durch das doppelt gebogene Band und durch die Platte und steckt eine Unterlagscheibe auf. Eine Klemmuffe (35) hält die Achse in ihrer Stellung fest.

BC7 ist eine Winkelstütze, 25 x 13 mm. Man erhält eine freie Lagerung oder Halterung für eine Achse.

BC1 är ett sätt att sammanfoga två remisar så att de kan roras fritt i förhållande till varandra. Detta kallas "låsmuttring". Hertil behövs två muttrar på den hållande bulten. Muttrarna får inte dragas åt för hårt mot remsan.

BC2 är en annan metod av "låsmuttring". Två muttrar, en över och en under remsan, används och skruvas mot remsan som framgår av pilarna.

BC3 är två remisar som är hopskarvade genom en kortare remsa b.

BC4 är två remisar som är sammansatta med två bultar och muttrar.

BC5 är en vinkelhållare (12c) som används för att fästa samman två remisar i en vinkel.

BC6 är ett hållbart axellager gjort av en dubbelböckad remsa (45) fastskruvad vid en plåt. Axeln löper genom den dubbelböckade remsan och plåten och en bricka är påtrådd varpå en fjäderklämma (35) används till att hålla axeln i läge.

BC7 är en 25 x 12 mm dubbelhållare (11a) som används för att utgöra ett förlängt axellager.

BC1 es un método de unir dos Tiras, de manera que puedan girar o moverse en mutua relación. Esto se llama en "contra-tuerca" y hace uso de dos tuercas para aguantar firme un perno. Las tuercas no han de apretar las Tiras muy firme.

BC2 es otro método de "contra-tuerca". Dos tuercas, una encima y otra debajo de la Tira (a) se aprietan contra ella girándose según indican las saetas.

BC3 es dos Tiras unidas punta a punta por otra Tira más corta (b).

BC4 es dos Tiras unidas con dos pernos y tuercas.

BC5 es un Soporte Obtusángulo (12c) que se usa para unir dos Tiras punta a punta en ángulo mutuo.

BC6 es un cojinete fuerte o soporte para una Varilla hecha con una Tira con doble encorvadura (45) empernada a una Placa. La Varilla se pasa por la Tira con doble encorvadura y la Placa, poniéndose una Arandela y se usa una Abrazadera de Resorte para aguantar la Varilla en posición.

BC7 es un Soporte Doble de 25 x 12 mm (11a) que se usa para facilitar un apoyo más extenso para una Varilla.

BC1 é uma maneira de juntar Tiras por forma a poderem girar ou articular em relação uma à outra. Isto é chamado o sistema de contra porca, fazendo uso de duas porcas no parafuso de segurança. As porcas não devem apertar as tiras firmemente.

BC2 é outra maneira de usar a "contra-porca" na junção de duas Tiras. Neste método duas porcas, a primeira por cima da Tira (a) e a segunda entre esta e a outra tira são apertadas pela forma como é indicada pelas setas.

BC3 consiste em juntar as extremidades de duas Tiras, ligando-as com uma Tira mais curta (b) aparafusada a ambas.

BC4 juntam-se duas Tiras com dois parafusos com porcas.

BC5 é um Suporte em Ângulo Obtuso (12c) utilizado para ligar as extremidades de duas Tiras formando ângulo.

BC6 é um suporte forte para uma Vareta rotatória montada numa Tira Dobrada Dupla (45) e segura a uma Placa. A Vareta é passada através da Tira Dobrada Dupla, da Placa e de uma Arruela colocada a seguir usando um Grampo de Mola (35) para manter a Vareta no lugar.

BC7 é um Suporte Duplo (11a) 25 x 12,5 mm, utilizado para prover melhor suporte para uma Vareta.

BC1 er en metode å sette sammen to skinner på, slik at de kan beveges i forhold til hverandre. Dette kallas "låsmuttring", og det trengs to muttere på den holdende skruen. Mutterne må ikke trekkes for hardt til mot skinnen.

BC2 er en annen metode av "låsmuttring", hvor to muttere, en over og en under skinnen (a), skrues mot skinnen som pilen viser.

BC3 er to skinner som er satt sammen ved hjelp av en kortere skinne (b).

BC4 er to skinner som er satt sammen ved to skruer og muttere.

BC5 er en vinkelbrakett (12c) som benyttes til å sette sammen to skinner til en vinkel.

BC6 er et aksellager for en roterende aksel, laget av en boyle med orer (45), skrudd fast til en plate. Akselen løper gjennom skinnen og platen, en skive er tredd innpå og blir holdt på plass av en fjærklammer (35). En annen form for samme konstruksjon er vist i BC13.

BC7 er en 25 x 12 mm dobbelbrakett (11a), festet til en plate eller annen del, og utgjør et forlengt aksellager.

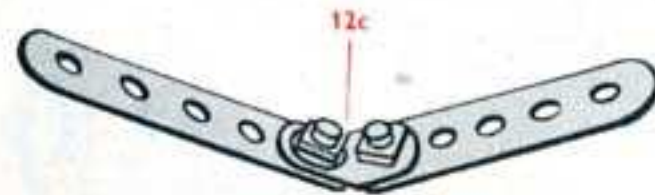

BC5

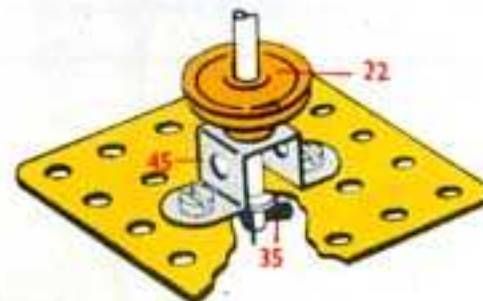

BC6

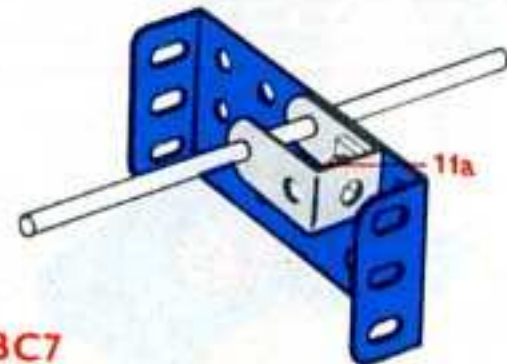

BC7

**BC8** is a support for a fixed Rod, which is held in a Bush Wheel (24b) bolted to a base-plate.

**BC9** is a Cord Anchoring Spring (176) providing a non-slip method of attaching Cord to a Rod. The Spring is fitted to the Rod by pushing it while turning it clockwise. Turn in the same direction when pulling the Spring off the Rod.

**BC10** is a brake for a winding handle of a crane, etc. formed by the head of a  $\frac{1}{2}$ " Bolt (111c) fixed in the boss of a Bush Wheel (24b) engaging a Bolt (37) when the Handle is pushed inward. The Handle must be free to slide about  $\frac{1}{2}$ " in its bearings so that when pulled outwards the bolt heads do not engage.

**BC11** is a method of assembling a jib-head pulley for a crane. The Pulley (23) is placed on a long Bolt.

**BC12** is two Angle Brackets (12) used to form a "U" shaped bridging piece.

**BC13** is an alternative form of bearing to BC6.

**BC14** is a crank formed by an Angle Bracket (12) fixed to a Pulley. A Strip is connected by a Bolt b, fitted with two Nuts, to the other lug of the Bracket. The Nuts are tightened together to grip the Angle Bracket but leave the Strip free to move on the Bolt.

**BC8** is een stevige steun voor een vaste as wordt hier verkregen door de as te bevestigen in een naafbuswiel (24b) dat op de grondplaat is gemonteerd.

**BC9** is een veeranker voor koord (176) geeft een niet-slippende bevestiging van een koord aan een as. Het veeranker wordt, al naar rechts draaiende, op de as geschoven zoals de pijlen aangeven. Wanneer het veeranker van de as af geschoven moet worden, dan ook naar rechts draaien.

**BC10** is een handige, goed bruikbare rem voor de opwind-kruk van een kraan o.i.d., bestaande uit een  $9\frac{1}{2}$  mm. bout (111c), aangebracht in de naaf van een naafbuswiel (24b) en die dan, wanneer de kruk gedraaid wordt, een 5 mm. bout (37) raakt. De kruk moet ca.  $\frac{1}{2}$  cm. vrij kunnen schuiven in zijn lager zodat bij het uitschuiven van de kruk met het naafbuswiel de beide bouten elkaar niet raken.

**BC11** is een systeem om een riemschijf te bevestigen in de kraan-arm-top van een eenvoudige kraan. De riemschijf (23) wordt op een lange bout geschoven.

**BC12** is twee hoeksteunen (12) aan elkaar geschroefd vormen een „U” vormig verbindingsstuk.

**BC13** is een andere vorm van de lagering dan die van BC6.

**BC14** is een manier om een kruk te maken van een hoeksteun (12) het is dan bevestigd aan de naaf van een riemschijf. Een strook is vervolgens met de bout b en twee moeren hieraan gemonteerd. Deze moeren zijn aan weerskanten stijf tegen de hoeksteun gedraaid en laten zo de strook vrij draaien om de bout.

**BC8** est un support solide pour un axe fixe, bloqué dans le moyeu d'une roue barillet boulonnée sur une plaque.

**BC9** fait voir comment on attache une ficelle sur une tringle de façon qu'elle ne glisse pas. On utilise un ressort d'attache pour corde (176) que l'on fait glisser sur la tringle tout en le tournant dans le sens des aiguilles d'une montre pour que les spires se desserrent. Tourner également dans ce sens pour dégager le ressort d'attache de la tringle.

**BC10** constitue un frein pour un treuil de grue, par exemple. La tête d'un boulon de 9,5 mm (111c) fixé dans le moyeu d'une roue barillet (24b) vient s'arrêter contre le boulon (37) lorsqu'on tourne la manivelle. Celle-ci doit pouvoir coulisser de 5 à 6 mm; de cette façon lorsqu'on la tire vers l'extérieur, les têtes des deux boulons ne peuvent pas se toucher.

**BC11** montre comment on monte une poulie à l'extrémité de la flèche d'une grue. La poulie (23) est placée sur un boulon de 9,5 mm.

**BC12** explique la façon de faire une pièce en "U" avec deux équerres boulonnées ensemble.

**BC13** fournit un palier différent de BC6.

**BC14** est un vilebrequin formé par une équerre (12) fixée sur le moyeu d'une poulie. L'autre côté de l'équerre porte une bande articulée grâce à un boulon b muni de deux écrous. Les écrous sont serrés de façon à bloquer l'équerre tout en laissant la bande libre de pivoter sur le boulon.

**BC8** est un robuste sostegno per un asse fisso, formato da un disco con mozzo (24b), avvitato alla piastra di base.

**BC9** è una molla di fissaggio per cordoncino (176) che permette di legare uno spago ad un asse così che non si sposti longitudinalmente lungo l'asse stesso. La molla si infila sull'asse facendola girare dalle frecce in modo che le spirali si allentino alquanto. Anche per togliere la molla si agisce nello stesso modo.

**BC10** è un freno per la manovella di una gru o altro modello, costituito dalla testa di una vite di mm. 9,5 (111c) avvitata nel mozzo di un disco (24b) che impegna una vite (37) quando si gira la manovella. L'asse della manovella deve avere un gioco di qualche millimetro in modo che, quando si tira all'infuori, le teste delle viti si disimpegnino.

**BC11** è l'estremità superiore di un braccio con puleggia per un semplice modello di gru. La puleggia (23) è montata sul gambo di una lunga vite.

**BC12** è un supporto ad "U" formato da due squadrette (12).

**BC13** è una variante della combinazione BC6.

**BC14** è un congegno di articolazione formato da una squadretta (12) fissata al mozzo di una puleggia. Una striscia è articolata su di una vite "b" assicurata con due dadi all'altro foro della squadretta. Infine i due dadi devono essere stretti contro ciascun lato del foro della squadretta lasciando libero il movimento della striscia sul gambo della vite.

**BC8** ist eine starke Halterung für eine feststehende Achse. Man schraubt dazu die Achse in ein Buchsrad (24b) und befestigt es auf einer Grundplatte.

**BC9** ist eine Befestigungsfeder für eine Schnur (176), die dafür sorgt, dass eine Schnur auf einer Achse nicht verrutschen kann. Will man die Feder auf der Achse befestigen, so drückt man sie auf und dreht sie dabei im Uhrzeigersinn. Wird die Feder von der Achse gezogen, so muss man sie in derselben Richtung drehen.



BC8



BC9

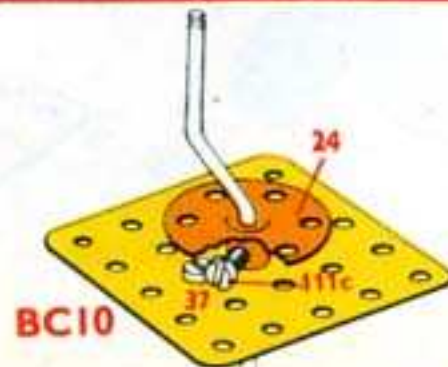

BC10



BC11



**BC10** ist eine wirkungsvolle Sperre für die Handkurbel eines Krans oder anderem. Sie besteht aus dem Kopfeiner 9,5 mm Schraube (111c), die in die Nabe eines Buchrades (24b) geschraubt ist, den eine Schraube (37) festhält, wann die Kurbel gedreht wird. Die Handkurbel muss in ihrer Lagerung etwa 5 mm freies Spiel haben, dass die Schraubenköpfe einander nicht festhalten, wenn man sie nach aussen zieht.

**BC11** ist die Montage der Spitze eines Kranbalkens mit einer Riemenscheibe bei einem einfachen Kran. Die Riemenscheibe (23) sitzt auf einer langen Schraube.

**BC12** zeigt zwei Winkelstützen (12), die so zusammengeschraubt sind, dass ein U-förmiges Stück entsteht.

**BC13** ist eine ähnliche Bauart für eine Lagerung wie BC6.

**BC14** ist eine Kurbelvorrichtung aus einer Winkelstütze (12), die an der Nabe einer Riemenscheibe befestigt ist. Ein Band ist durch eine Schraube "b", die mit 2 Muttern versehen ist, mit dem anderen Arm der Winkelstütze verbunden. Die Muttern werden so gegeneinander angezogen, dass sie nur das Winkelstück halten, aber dass sich das Band zugleich frei auf der Schraube bewegen lässt.

**BC8** är ett starkt fäste för en fast axel som skruvas fast i en centerskiva (24b) fastsatt på en flänsplåt.

**BC9** är en förankringsfjäder (176) för Meccano snöre som ger en slirsäker metod att fästa ette snöre vid en axel. Fjädern fästes på axeln genom att man vrider den motsols som framgår av pilarna varvid spiralens grepp om axeln lättas. Vrid i samma riktning när fjädern drages av axeln.

**BC10** är en användbar broms för en kranvev o.s.v. Den består av en centerskiva (24b) i vars nav fästs en 9j mm bult (111c), som stoppas av en bult (37) när vevan vrider. Vevan måste kunna glida ca 6 mm i sitt lagerblock så att den, när vevan drages utåt, obehindrat kan vridas utan att bultarnas huvuden stöter ihop.

**BC11** är en metod att montera ett linhjul på en enkel kranarm. Linhjulet (23) sitter på en lång bult.

**BC12** är två vinkelhållare (12) sammanskruvade till ett "U".

**BC13** är ett annat sätt att göra ett axellager liknande BC6.

**BC14** är en vevanordning gjord av en vinkelhållare (12) fastsatt med skruvar och muttrar i navet på en 25 mm centerskiva. En rem är ansluten med en bult b, försedd med två muttrar, till den andra flänsen på hållaren. Muttrarna är fastskruvade i vinkelhållaren, men tillåter remsan att röra sig fritt runt bulten.

**BC8** es un apoyo fuerte para una Varilla fija, apretada en una Rueda con buje (24b) empennada a una placa de base.

**BC9** es un Resorte de enganche para cuerda (176) con el cual se obtiene un método firme de agregar la Cuerda a la Varilla. El Resorte se agrega a la Varilla empujándolo mientras se le da vuelta de izquierda a derecha según indican las saetas. Cuando quiera tirarse el Resorte fuera de la Varilla se girar en la misma dirección.

**BC10** es un freno útil para el mango de arrollamiento de una grua, formado con la cabeza de un Perno de 9j mm (111c) fijo en el cubo de una Rueda con buje (24b) que engrana un Perno 37 cuando se entromete el Mango de cigüeña. Este Mango ha de ser libre para deslizarse 6 mm en sus soportes, de manera que cuando se tira hacia fuera las cabezas de perno no engranan.

**BC11** es un método de montar una polea de aguilón para una grua. La Polea (23) se coloca en un perno largo.

**BC12** se compone de dos Soportes Angulares (12) empennados juntos para formar una pieza de unión en forma de U.

**BC13** es una forma alternativa de cojinetes para BC6.

**BC14** es una cigüeña hecha con un Soporte Angular (12) fijo a una Polea. Se empalma una Tira con un Perno b, que lleva dos tuercas, a la otra lengüeta del Soporte. Se aprietan las tuercas una a la otra para apretar el Soporte Angular pero se deja la Tira libre para que pueda moverse en el perno.

**BC8** er et feste for en aksel, som er skrudd fast til en sentrumskive (24b) fesset til en place.

**BC9** er en ankerfjær (176) som gir en glisikker metode til å feste et snøre til en aksel. Fjæren festes til akselen ved at man vrir den "med somen" som det fremgår av pilene. Vri i samme retning når fjæren trekkes av akselen.

**BC10** er en bremse for en kranseiv o.l. Den består av en sentrumskive (24b), og i navet på denne er fesset en 9j mm bult, som stoppes av en skrue (37) når sveiven vrir. Sveiven må kunne gli ca. 6 mm i sitt lager, slik at ikke hodene på skruene støter sammen når sveiven dras utover.

**BC11** er en metode til å montere drivhjul på en kranarm. Drivhjulet sitter på en lang bolt.

**BC12** er to vinkelbraketter (12) skrudd sammen for "U" formede konstruksjoner.

**BC13** er en annen måte å lage et aksellager lik BC6.

**BC14** er en sveivanordning laget av en vinkelbrakett (12) fastsatt med skruer og muttere i navet på en 25 mm sentrumskive. En skinne er satt sammen med en skrue b, forsynt med to muttere til den andre flaten på braketten. Mutterne er fastskrudd til vinkelbraketten, men tillater skinnen å bevege seg fritt rundt skruen.

**BC8** é um suporte forte para uma Vareta fixada, o qual se consegue segurando a Vareta a uma Roda de Bucha (24b) aparafusada a uma placa de base.

**BC9** é o método para prender Cordela uma Mola para Fixar Cordel enfiada numa Vareta sem que o Cordel deslize Para tal, a Mola é fixada na Vareta girando-a no sentido dos ponteiros do relógio. Para retirar a Mola deverá proceder-se da mesma maneira.

**BC10** é um freio útil para uma manivela de enrolamento dum guindaste, etc., feito da cabeça dum Porca de 10 mm. (111c) fixada na bossa dum Roda de Bucha (24b) engrenan do uma Porca (37) quando a Manivela é movida. A Manivela deve ficar com folga por forma a poder deslizar cerca de 6,5 mm. nos seus eixos para que quando for puxada para fora, as cabeças dos parafusos não empanquem.

**BC11** é um método de montagem da polia no extremidade do braço de um guindaste A Polia (23) é colocad a num parafuso.

**BC12** é o processo de utilizar dois Suportes Angulares (12) aparafusados um ao outro em forma de "U", que por sua vez se ligam a duas tiras.

**BC13** é uma alternativa de suporte de vareta ao BC6.

**BC14** é uma rodã de manivela formada por um Suporte Angular (12) fixo à bossa de uma Polia. A Tira é ligada pelo Parafuso (b) e fixada por duas porcas à parte vertical do Suporte Angular. As porcas são bem apertadas de encontro ao Suporte Angular deixando folga do lado da cabeça do parafuso para que a Tira possa mover facilmente no parafuso.

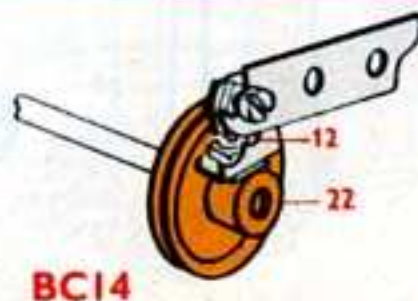
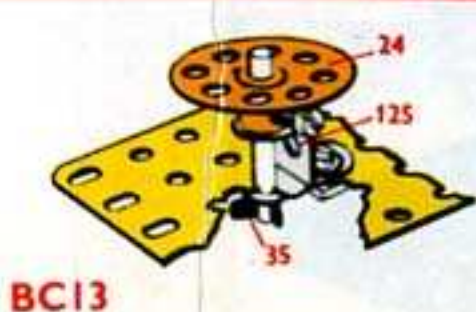
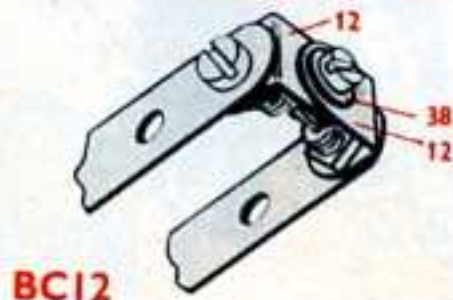

## 2.1.

Builders' crane  
Bouwkraan  
Grue de bâtiment  
Gru per cantiere  
Baukran  
Byggnadskran  
Grúa para obras  
Guindaste de construção  
Kran for husbygging

2- 2	2- 22a
4- 5	4- 35
3- 10	19- 37a
5- 12	17- 37b
1- 16	5- 38
1- 18b	2- 48a
1- 22	1- 111c

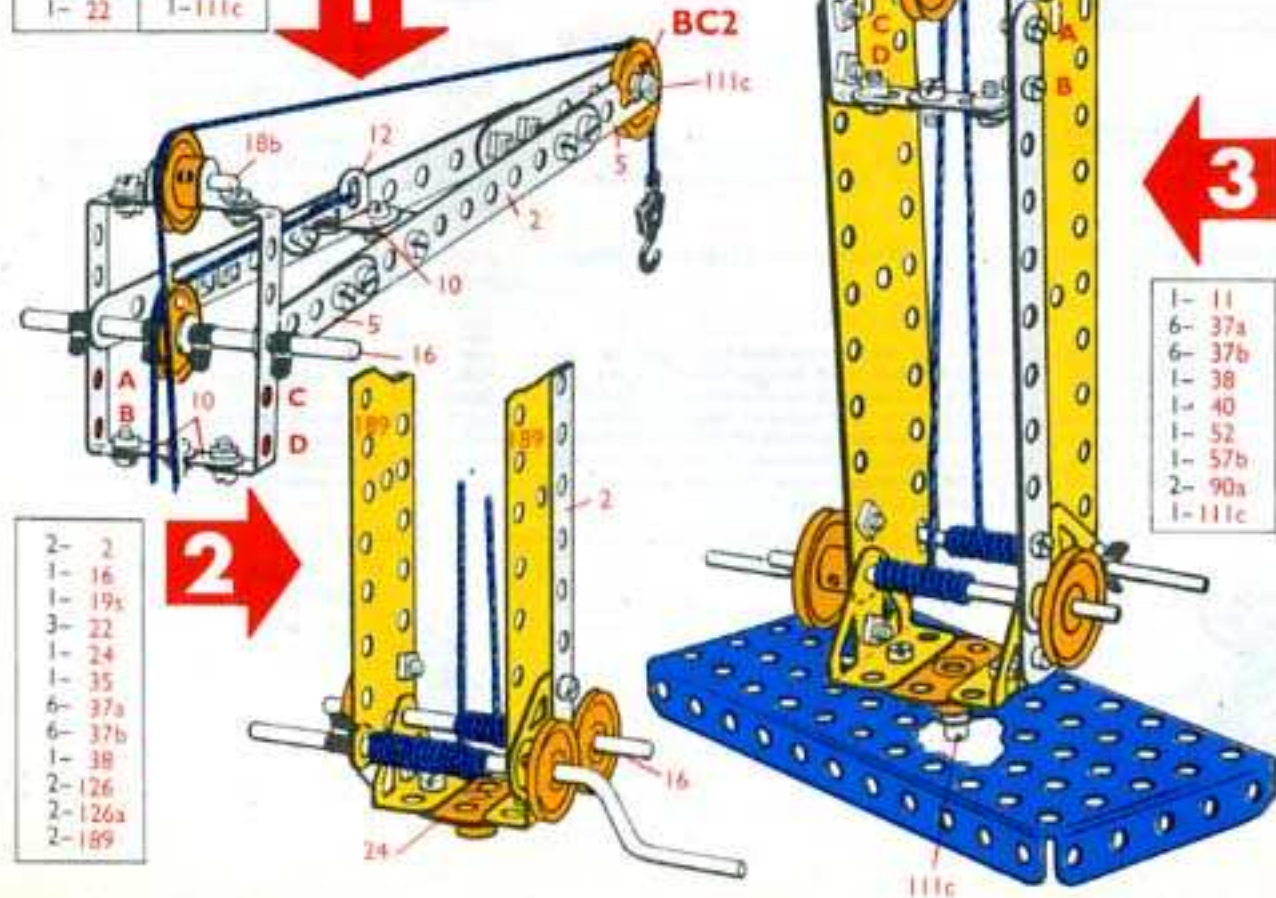

4- 2	31- 37a
4- 5	29- 37b
3- 10	7- 38
1- 11	1- 40
5- 12	2- 48a
2- 16	1- 52
1- 18b	1- 57b
1- 19a	2- 90a
4- 22	2- 111c
2- 22a	2- 126
1- 24	2- 126a
5- 35	2- 189

2- 2
1- 16
1- 19a
3- 22
1- 24
1- 35
6- 37a
6- 37b
1- 38
2- 126
2- 126a
2- 189

1- 11
6- 37a
6- 37b
1- 38
1- 40
1- 52
1- 57b
2- 90a
1- 111c

## 2.2.

Helicopter  
Hefschroefvliegtuig  
Hélicoptère  
Elicottero  
Hubschrauber  
Helikopter  
Helicóptero

2- 10	6- 38
1- 11	2- 48a
8- 12	2- 111c
1- 16	1- 125
2- 22	2- 126
2- 22a	1- 126a
1- 24	2- 155
24- 37a	1- 189
20- 37b	2- 193

4- 2
4- 5
2- 10
1- 11
8- 12
1- 16
2- 22
2- 22a
1- 24
38- 37a
34- 37b
7- 38
2- 48a
2- 90a
2- 111c
1- 125
2- 126
2- 126a
2- 155
1- 189
2- 193
2- 194

4- 2
4- 5
14- 37a
14- 37b
1- 38
2- 90a
1- 126a
2- 194

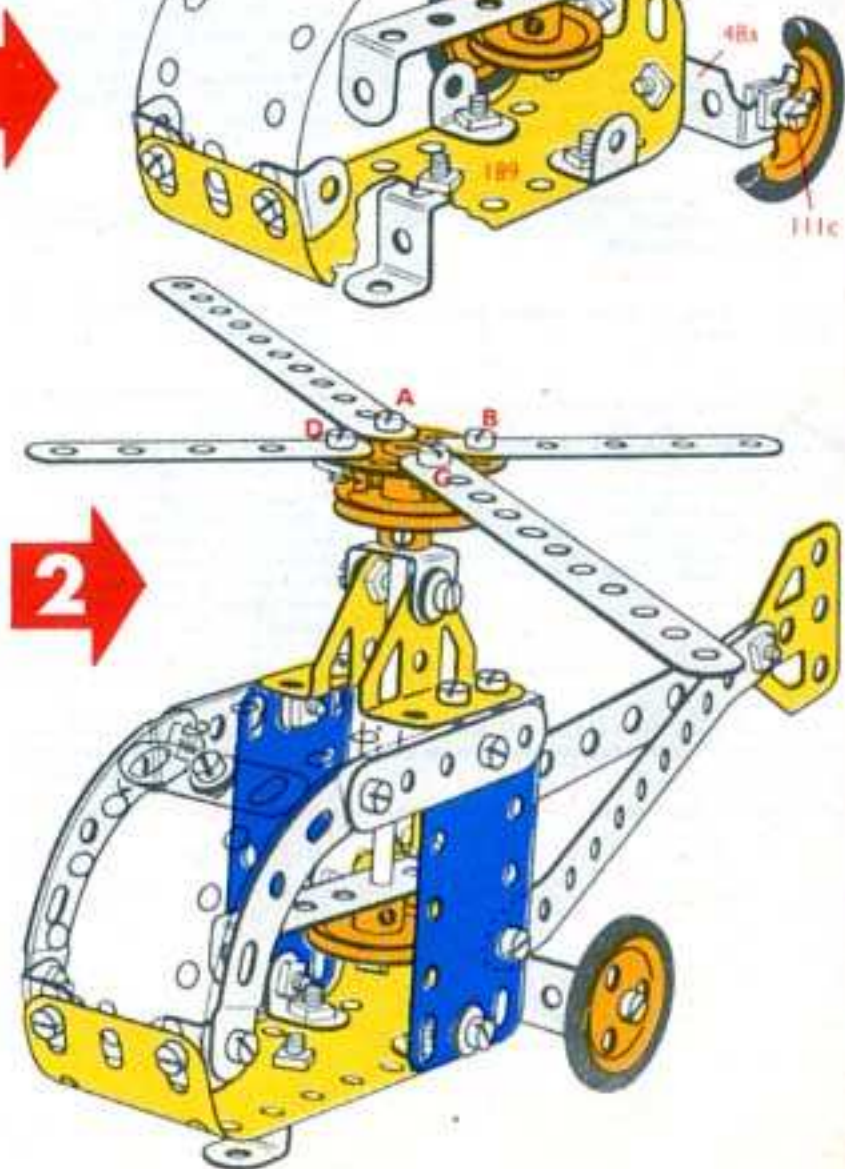

**2.3.**  
 Dockside crane  
 Havenkraan  
 Grue de docks  
 Gru portuale  
 Dockkran  
 Hamnkran  
 Grúa de muelle  
 Grua portuária  
 Kai-kran

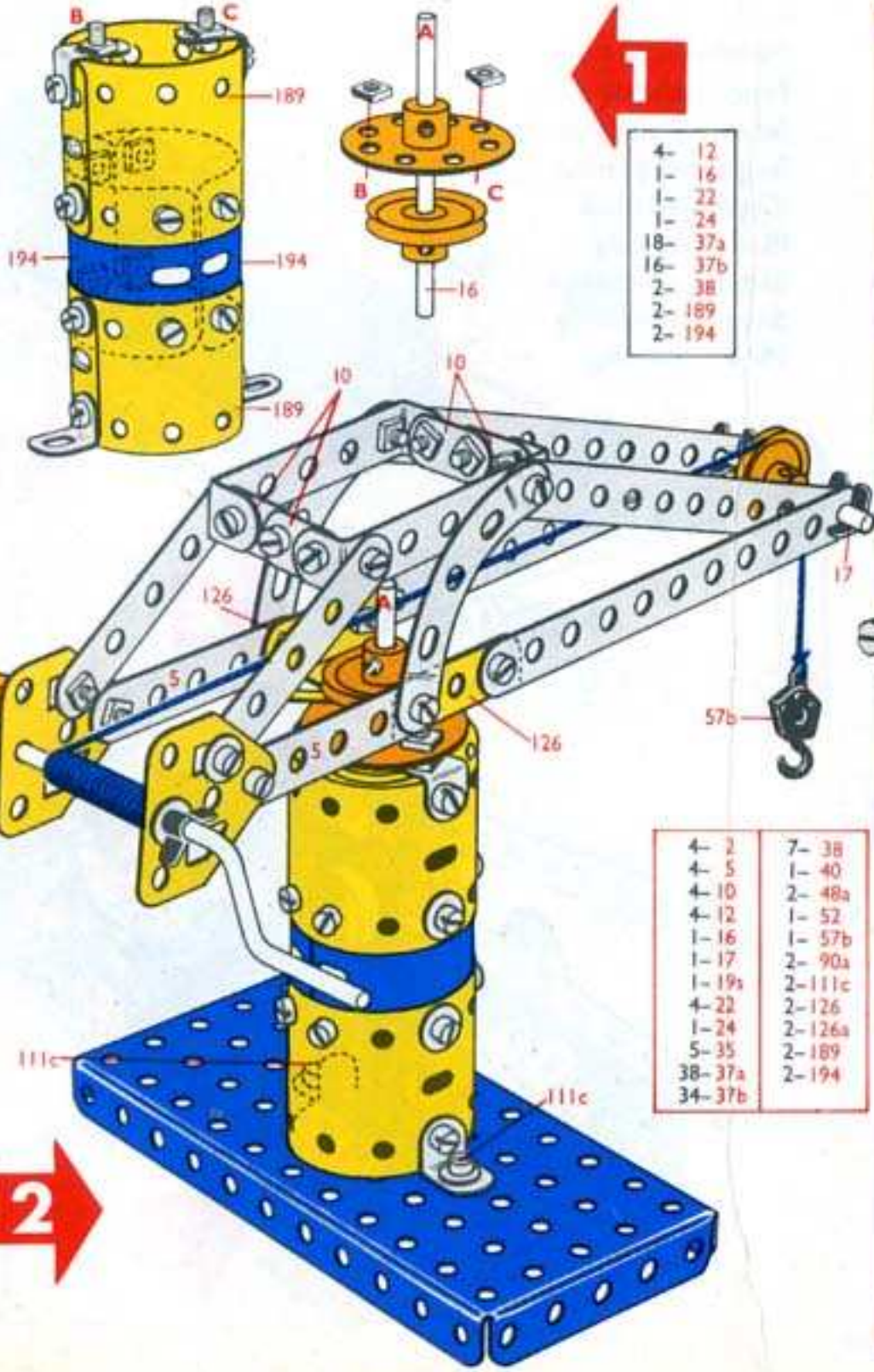

4-	12
1-	16
1-	22
1-	24
18-	37a
16-	37b
2-	38
2-	189
2-	194

4-	2	7-	38
4-	5	1-	40
4-	10	2-	48a
4-	12	1-	52
1-	16	1-	57b
1-	17	2-	90a
1-	19a	2-	111c
4-	22	2-	126
1-	24	2-	126a
5-	35	2-	189
38-	37a	2-	194
34-	37b		

4-	2
4-	5
4-	10
1-	17
1-	19a
3-	22
5-	35
20-	37a
18-	37b
5-	38
1-	40
2-	48a
1-	52
1-	57b
2-	90a
2-	111c
2-	126
2-	126a

**2.4.**  
 Aeroplane  
 Vliegtuig  
 Avion  
 Aeroplano  
 Flugzeug  
 Flygplan  
 Avión  
 Avião  
 Fly

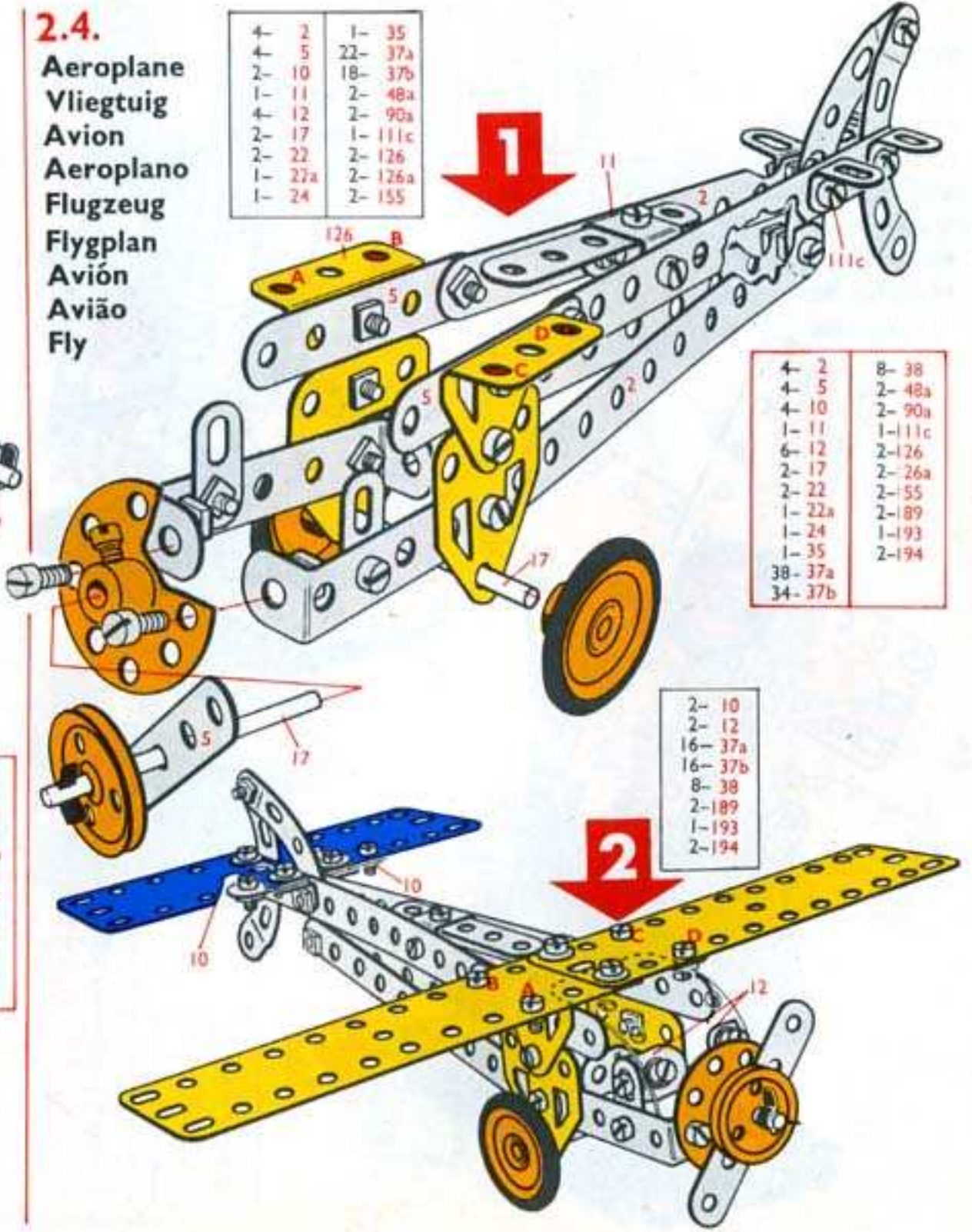

4-	2	1-	35
4-	5	22-	37a
2-	10	18-	37b
1-	11	2-	48a
4-	12	2-	90a
2-	17	1-	111c
2-	22	2-	126
1-	27a	2-	126a
1-	24	2-	155

4-	2	8-	38
4-	5	2-	48a
4-	10	2-	90a
1-	11	1-	111c
6-	12	2-	126
2-	17	2-	26a
2-	22	2-	55
1-	22a	2-	189
1-	24	1-	193
1-	35	2-	194
38-	37a		
34-	37b		

2-	10
2-	12
16-	37a
16-	37b
8-	38
2-	189
1-	193
2-	194

**2.5.**  
 Windmill  
 Windmolen  
 Moulin à vent  
 Mulino a vento  
 Windmühle  
 Väderkvarn  
 Molino de viento  
 Moinho de vento  
 Vindmølle

4- 2	2- 38
4- 5	2- 48a
8- 12	1- 52
2- 17	2- 90a
1- 19s	2- 126
3- 22	2- 126a
* 1- 23a	1- 155
1- 24	* 1- 186b
29- 37a	1- 213
29- 37b	

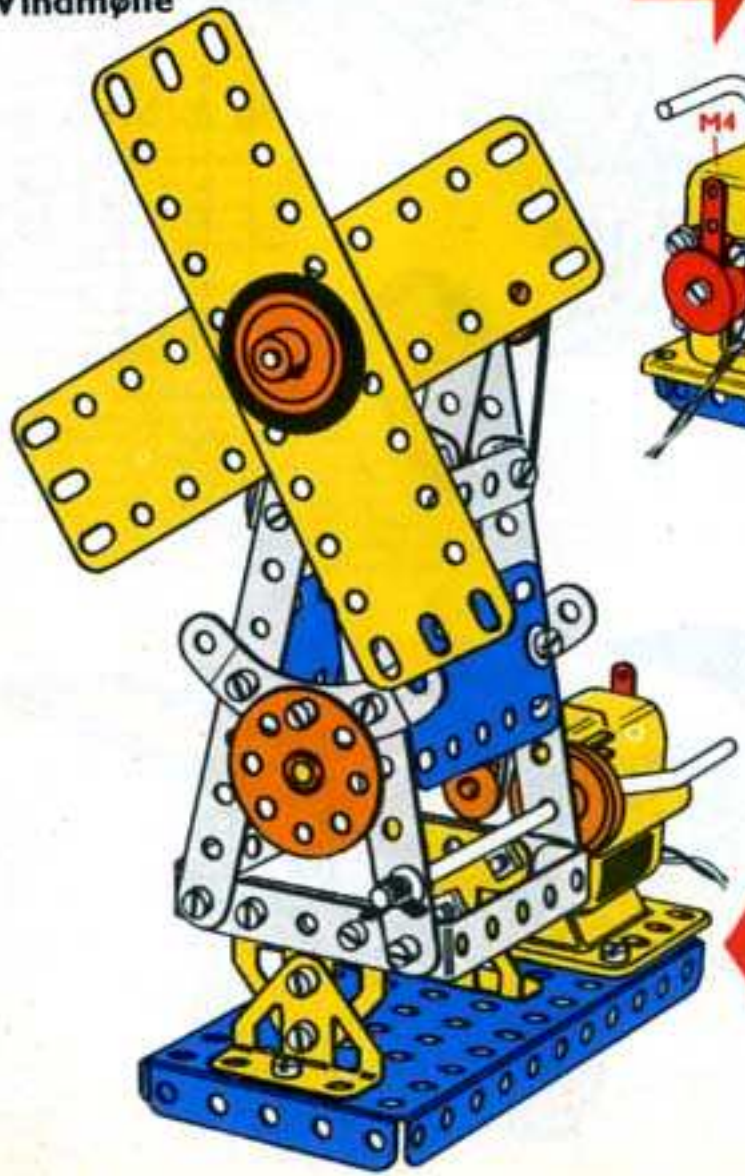
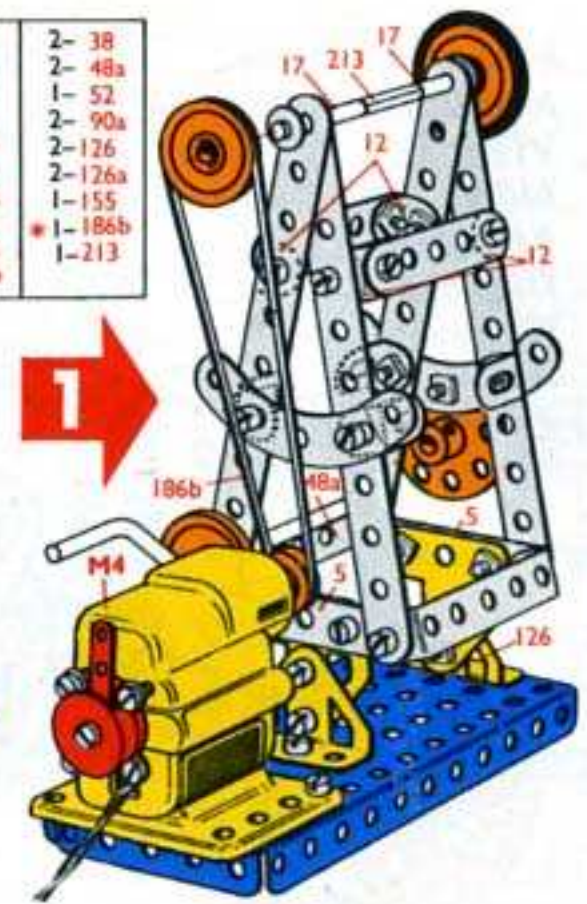

4- 2	4- 5	8- 12	2- 17	1- 19s	4- 22	* 1- 23a	1- 24	1- 35	33- 37a	33- 37b	7- 38	2- 48a	1- 52	2- 90a	2- 126	2- 126a	2- 155	* 1- 186b	2- 189	2- 194	2- 189	1- 213	* 1- M4
------	------	-------	-------	--------	-------	----------	-------	-------	---------	---------	-------	--------	-------	--------	--------	---------	--------	-----------	--------	--------	--------	--------	---------

1- 22	4- 37a	4- 37b	5- 38	1- 155	2- 189	2- 194
-------	--------	--------	-------	--------	--------	--------

\* Not included in set

**2.6.**  
 Mechanical saw  
 Mechanische zaag  
 Scie mécanique  
 Sega meccanica  
 Sägemaschine  
 Mekanisk såg  
 Sierra mecánica  
 Serra mecânica  
 Mekanisk sag

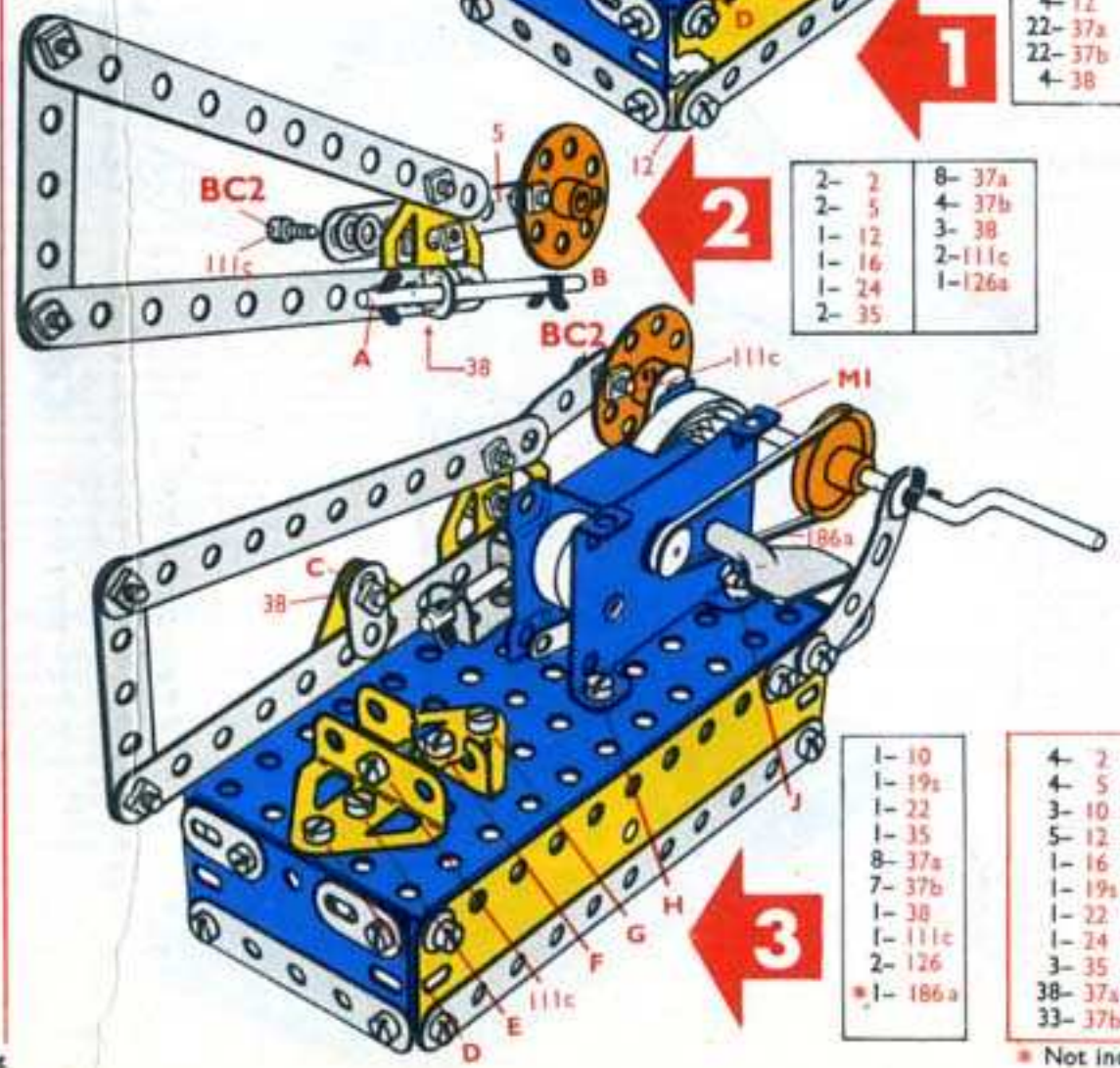
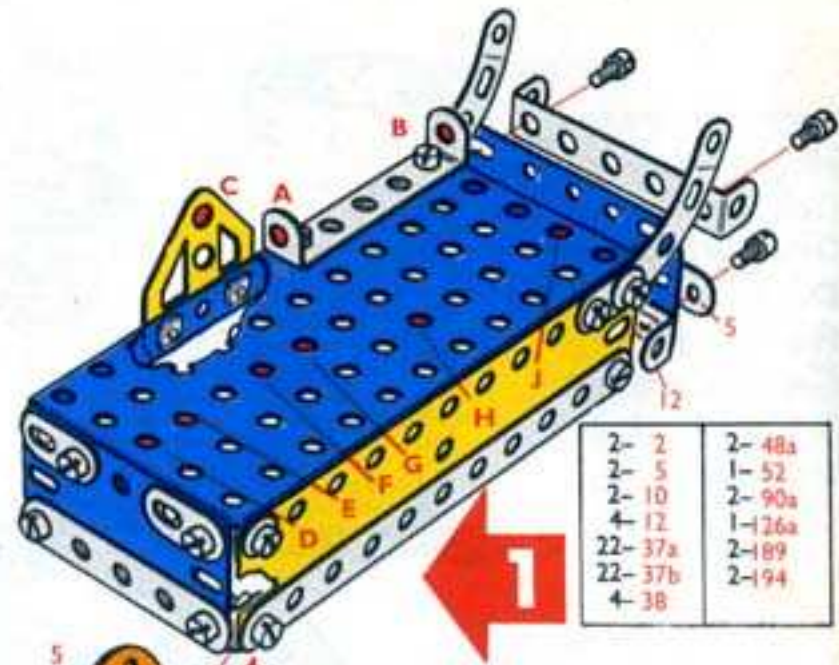

2- 2	2- 48a
2- 5	1- 52
2- 10	2- 90a
4- 12	1- 126a
22- 37a	2- 189
22- 37b	2- 194
4- 38	

2- 2	8- 37a
2- 5	4- 37b
1- 12	3- 38
1- 16	2- 111c
1- 24	1- 126a
2- 35	

1- 10	1- 19s	1- 22	1- 35	8- 37a	7- 37b	1- 38	1- 22	1- 24	2- 126	* 1- 186a
-------	--------	-------	-------	--------	--------	-------	-------	-------	--------	-----------

4- 2	8- 38
4- 5	2- 48a
3- 10	1- 52
5- 12	2- 90a
1- 16	3- 111c
1- 19s	2- 126
1- 22	2- 126a
1- 24	* 1- 186a
3- 35	2- 189
38- 37a	2- 194
33- 37b	* 1- M1

\* Not included in set

**2.7.**  
 Scooter  
 Motoleggera  
 Motorroller  
 Moto  
 Vespa

- 1**
- 1- 2
  - 3- 5
  - 1- 11
  - 3- 12
  - 1- 16
  - 2- 17
  - 1- 18b
  - 2- 22
  - 6- 35
  - 10- 37a
  - 10- 37b
  - 7- 38
  - 2- 48a
  - 2- 90a
  - 2- 142c

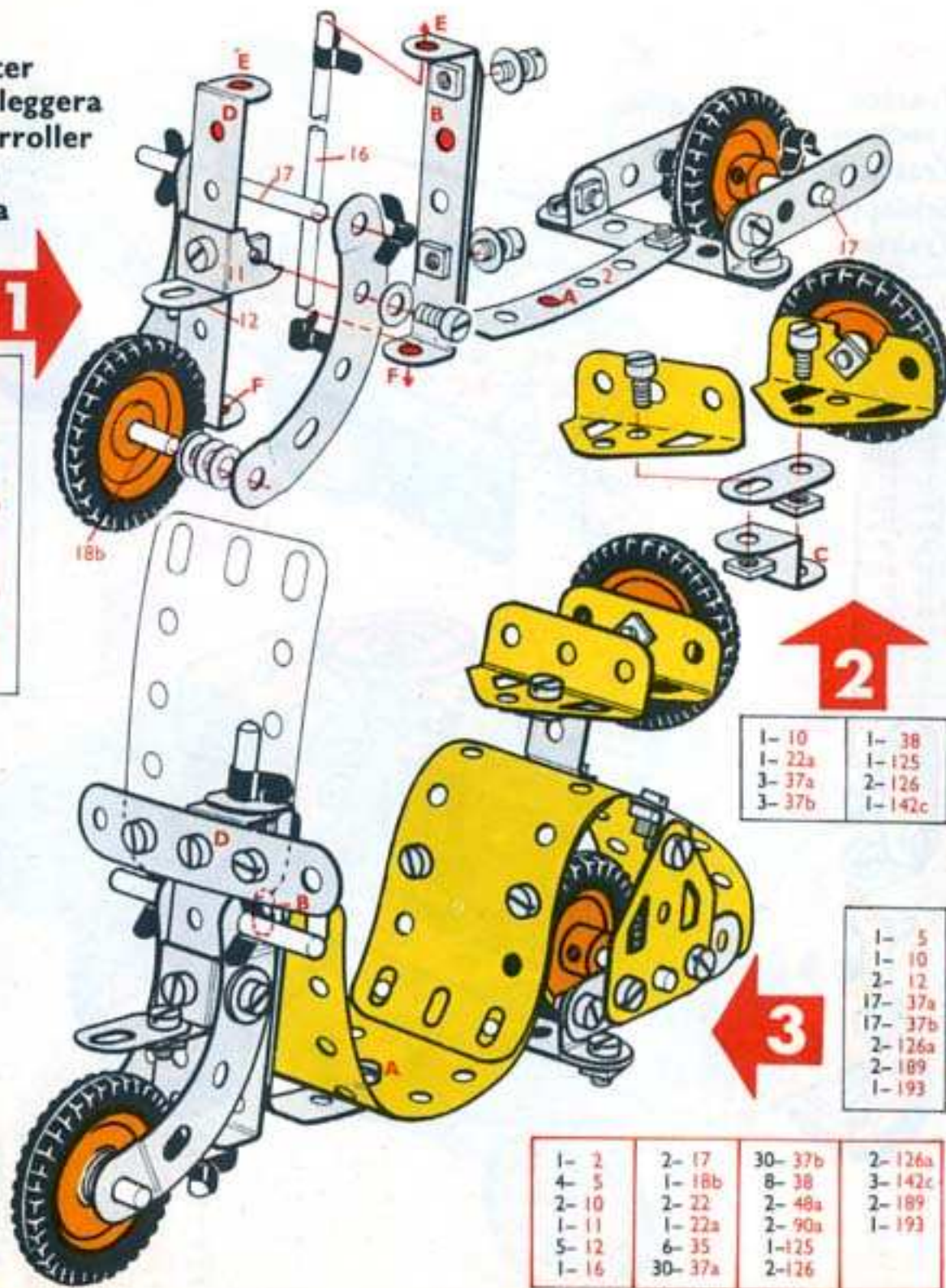

- 2**
- 1- 10
  - 1- 22a
  - 3- 37a
  - 3- 37b
  - 1- 38
  - 1- 125
  - 2- 126
  - 1- 142c

- 3**
- 1- 5
  - 1- 10
  - 2- 12
  - 17- 37a
  - 17- 37b
  - 2- 126a
  - 2- 189
  - 1- 193

- |       |         |         |         |
|-------|---------|---------|---------|
| 1- 2  | 2- 17   | 30- 37b | 2- 126a |
| 4- 5  | 1- 18b  | 8- 38   | 3- 142c |
| 2- 10 | 2- 22   | 2- 48a  | 2- 189  |
| 1- 11 | 1- 22a  | 2- 90a  | 1- 193  |
| 5- 12 | 6- 35   | 1- 125  |         |
| 1- 16 | 30- 37a | 2- 126  |         |

**2.8.**  
 Garage Crane  
 Garagekraan  
 Grue de garage  
 Paranco per  
 autorimessa  
 Garagenkran  
 Bilkran  
 Grúa para garaje  
 Talha de garage  
 Garasje-kran

- 1**
- |         |         |
|---------|---------|
| 1- 17   | 1- 52   |
| 1- 22   | 2- 111c |
| 2- 22a  | 2- 126  |
| 20- 37a | 2- 126a |
| 14- 37b | 2- 142c |
| 1- 38   | 1- 155  |
| 2- 48a  | 2- 189  |

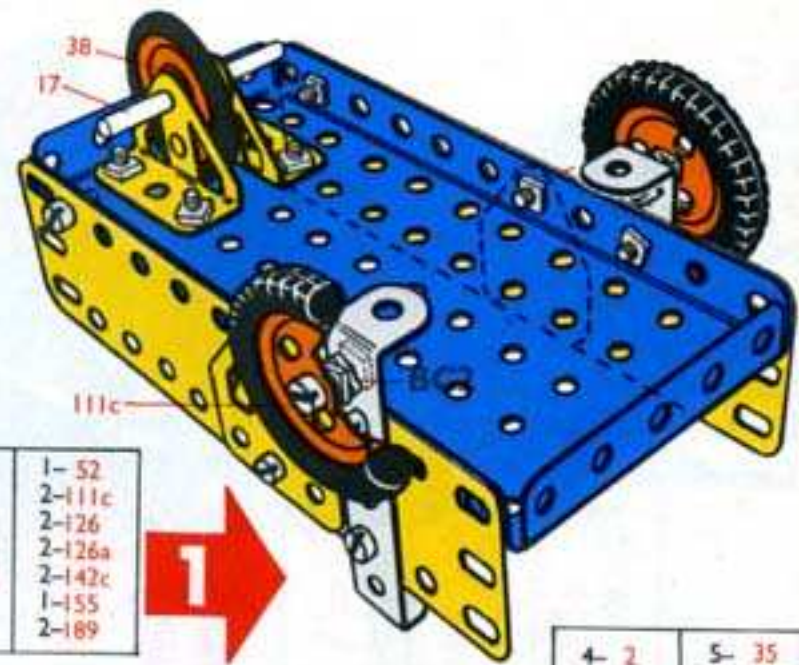

- 2**
- |        |         |
|--------|---------|
| 4- 2   | 5- 35   |
| 4- 5   | 17- 37a |
| 2- 10  | 18- 37b |
| 1- 11  | 7- 38   |
| 4- 12  | 1- 40   |
| 2- 16  | 1- 57b  |
| 1- 18b | 2- 90a  |
| 1- 19a | 1- 111c |
| 3- 22  | 1- 213  |
| 1- 24  |         |

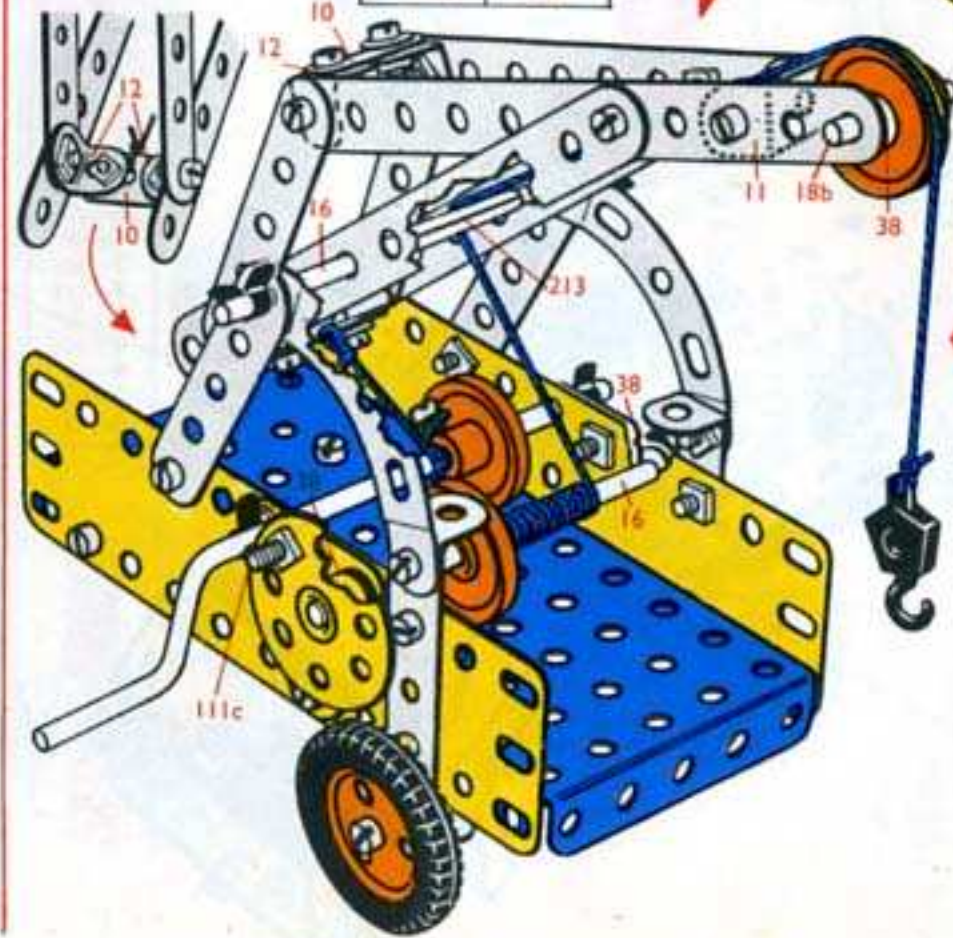

- 3**
- |         |         |
|---------|---------|
| 4- 2    | 32- 37b |
| 4- 5    | 8- 38   |
| 2- 10   | 1- 40   |
| 1- 11   | 2- 48a  |
| 4- 12   | 1- 52   |
| 2- 16   | 1- 57b  |
| 1- 17   | 2- 90a  |
| 1- 18b  | 3- 111c |
| 1- 19a  | 2- 126  |
| 4- 22   | 2- 126a |
| 2- 22a  | 2- 142c |
| 1- 24   | 1- 155  |
| 5- 35   | 2- 189  |
| 37- 37a | 1- 213  |

**2.9.**  
 Lifting Shovel  
 Mechanische schop  
 Pelle de levage  
 Motopala  
 Ladeschaufel  
 Lyftskopa  
 Pala cargadora  
 Pá de levantamento  
 Løfteskuff

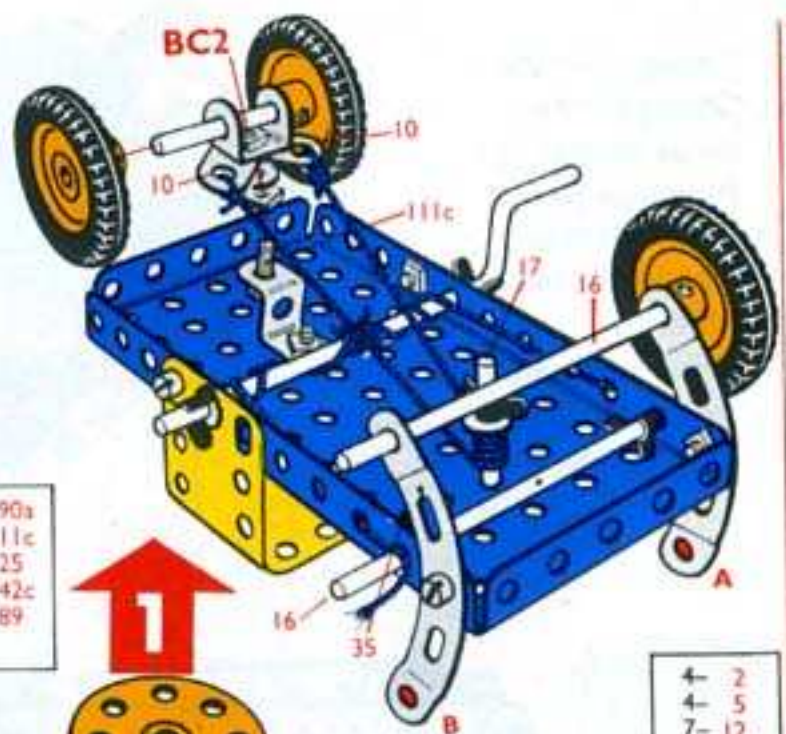

2- 10	5- 35	2- 90a
1- 11	7- 37a	1-111c
2- 16	5- 37b	1-125
2- 17	4- 38	4-142c
1- 19a	1- 40	1-189
4- 22	1- 52	

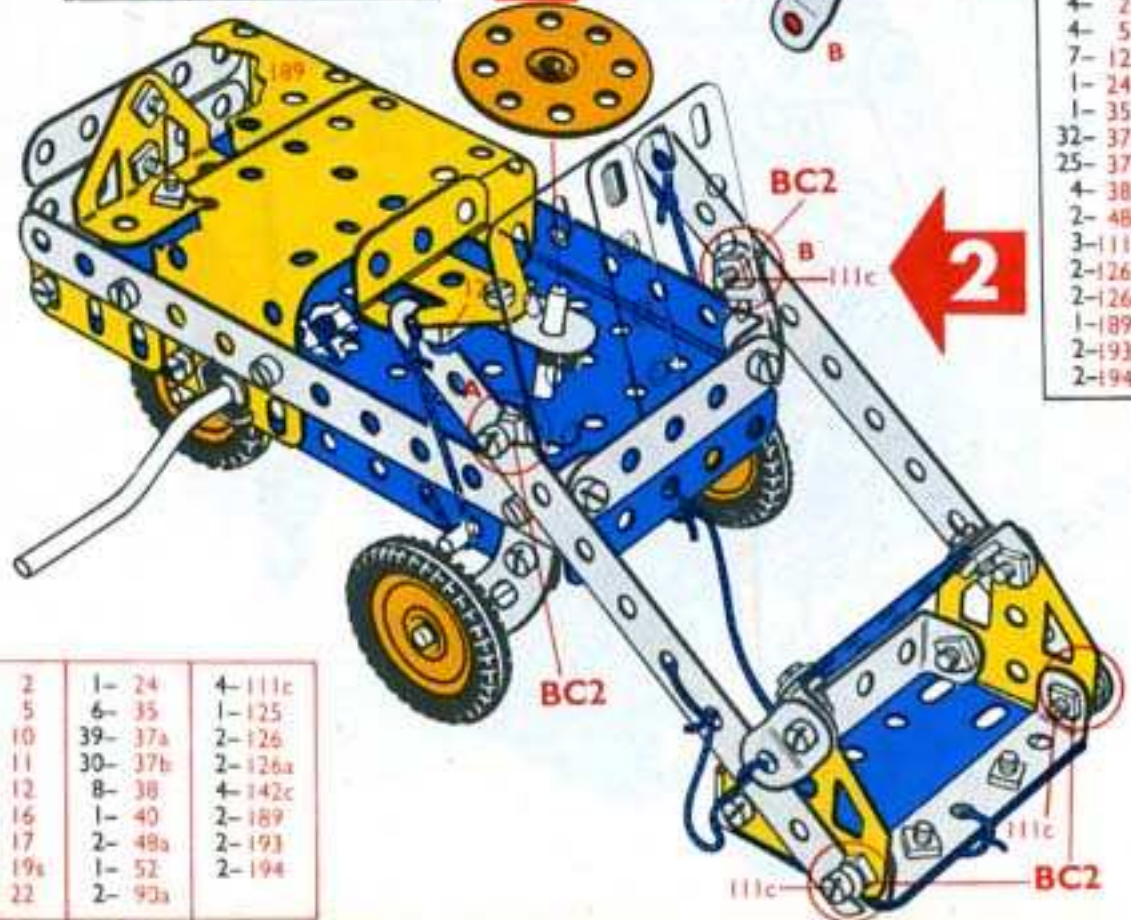

4- 2	1- 24	4-111c
4- 5	6- 35	1-125
2- 10	39- 37a	2-126
1- 11	30- 37b	2-126a
7- 12	8- 38	4-142c
2- 16	1- 40	2-189
2- 17	2- 48a	2-193
1- 19a	1- 52	2-194
4- 22	2- 90a	

4- 2
4- 5
7- 12
1- 24
1- 35
32- 37a
25- 37b
4- 38
2- 48a
3-111c
2-126
2-126a
1-189
2-193
2-194

**2.10.**  
 Tractor  
 Tracteur  
 Trattore  
 Schlepper  
 Traktor

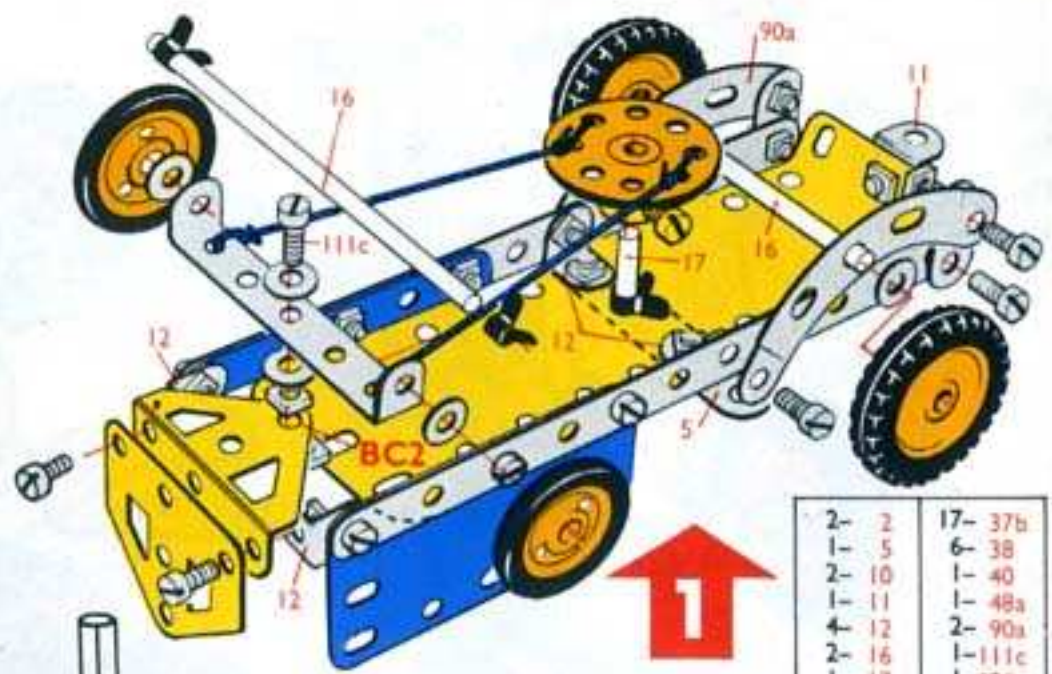

2- 2
3- 5
2- 10
4- 12
1- 17
1- 18b
1- 22
3- 35
16- 37a
16- 37b
2- 38
1- 48a
1-125
1-126
1-126a
2-194
1-213

2- 2	17- 37b
1- 5	6- 38
2- 10	1- 40
1- 11	1- 48a
4- 12	2- 90a
2- 16	1-111c
1- 17	1-126
2- 22	1-126a
2- 22a	2-142c
1- 24	2-155
3- 35	1-189
19- 37a	

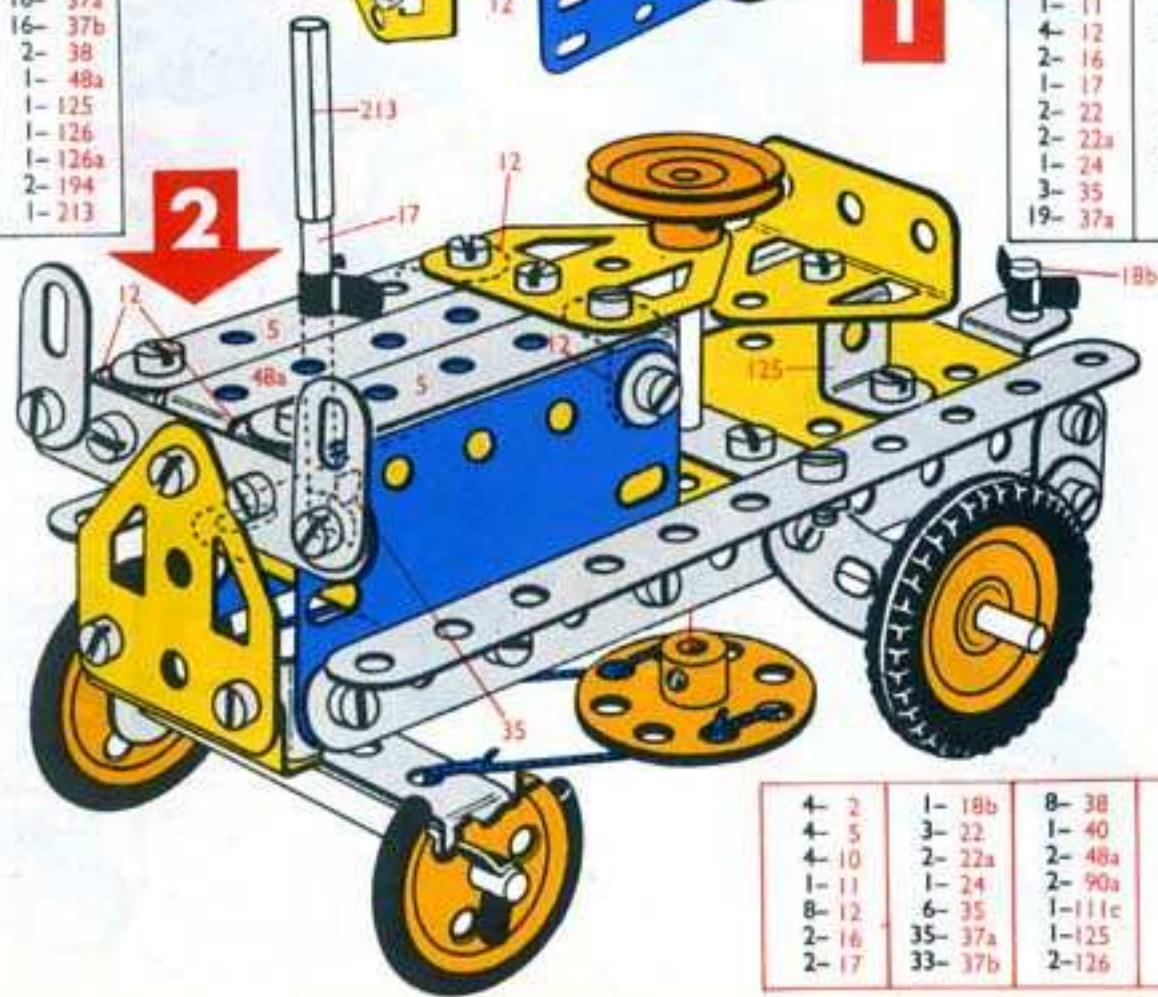

4- 2	1- 18b	8- 38	2-126a
4- 5	3- 22	1- 40	2-142c
4-10	2- 22a	2- 48a	2-155
1- 11	1- 24	2- 90a	1-189
8-12	6- 35	1-111c	2-194
2- 16	35- 37a	1-125	1-213
2- 17	33- 37b	2-126	

**2.11.**  
**Racing Car**  
**Racewagen**  
**Voiture de course**  
**Automobile tipo**  
**competizione**  
**Rennwagen**  
**Racerbil**  
**Coche de carreras**  
**Carro de corridas**

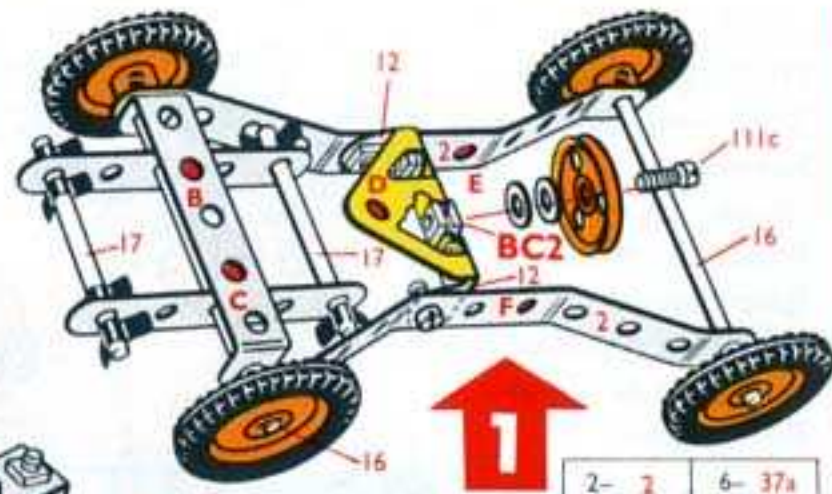

2-	2	6-	37a
2-	5	4-	37b
2-	12	2-	38
2-	16	1-	48a
2-	17	1-	111c
4-	22	1-	126
1-	22a	4-	142c
6-	35		

1-	2	1-	48a
2-	5	1-	126
2-	10	1-	126a
6-	12	2-	189
24-	37a	1-	193
24-	37b	1-	194
5-	38		

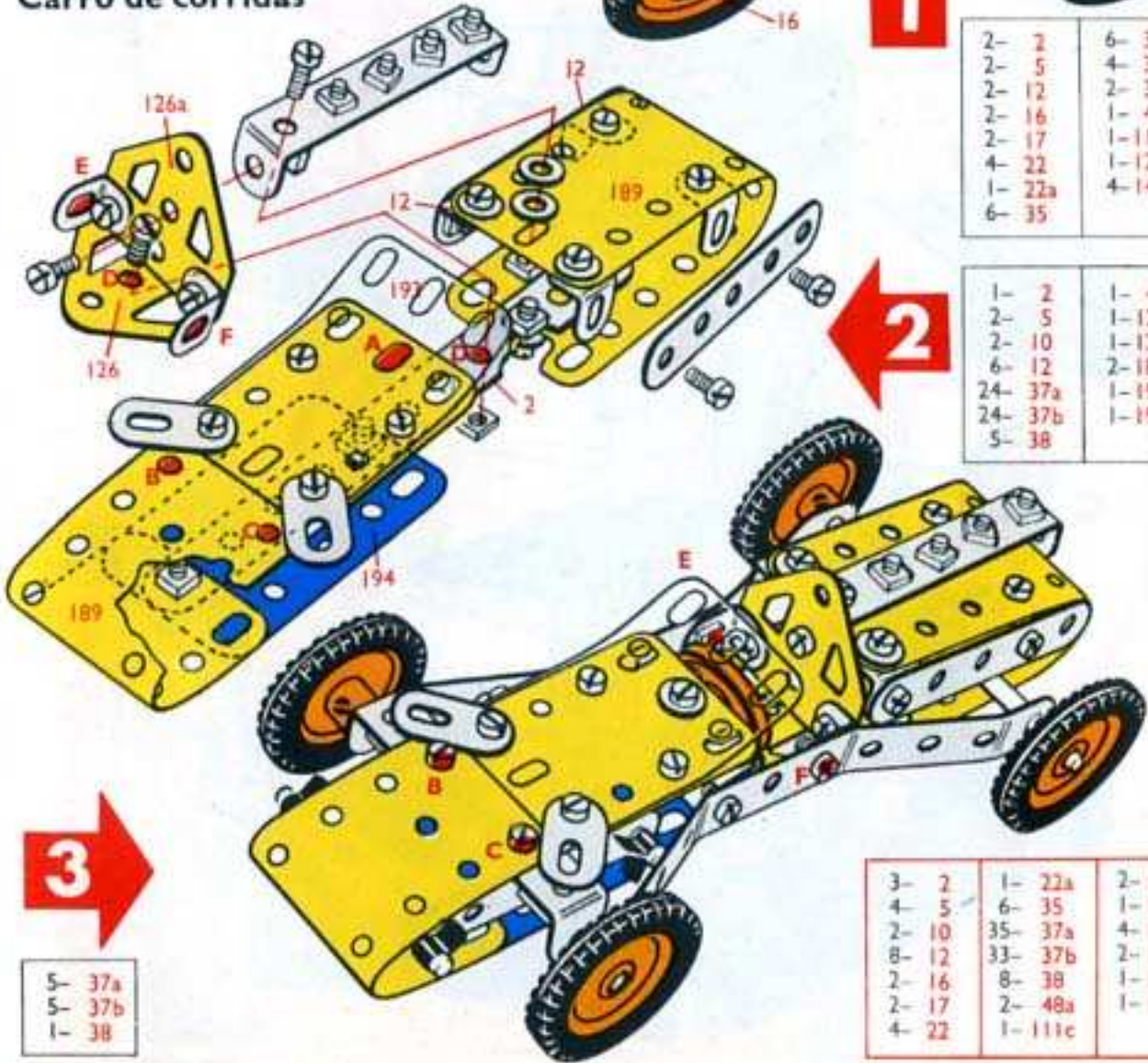

3-	2	1-	22a	2-	126
4-	5	6-	35	1-	126a
2-	10	35-	37a	4-	142c
8-	12	33-	37b	2-	189
2-	16	8-	38	1-	193
2-	17	2-	48a	1-	194
4-	22	1-	111c		



5-	37a
5-	37b
1-	38

**2.12.**  
**Fork Lift Truck**  
**Vorkheftruck**  
**Chariot élévateur à fourche**  
**Carrello elevatore a forca**  
**Gabelstapler**  
**Gaffeltruck**  
**Carretilla elevadora de horquilla**  
**Carrinho com forquilha de elevação**

2-	5	14-	37b
4-	12	2-	38
1-	18b	2-	90a
1-	22	2-	111c
1-	22a	2-	126
1-	24	2-	126a
2-	35	1-	155
14-	37a		

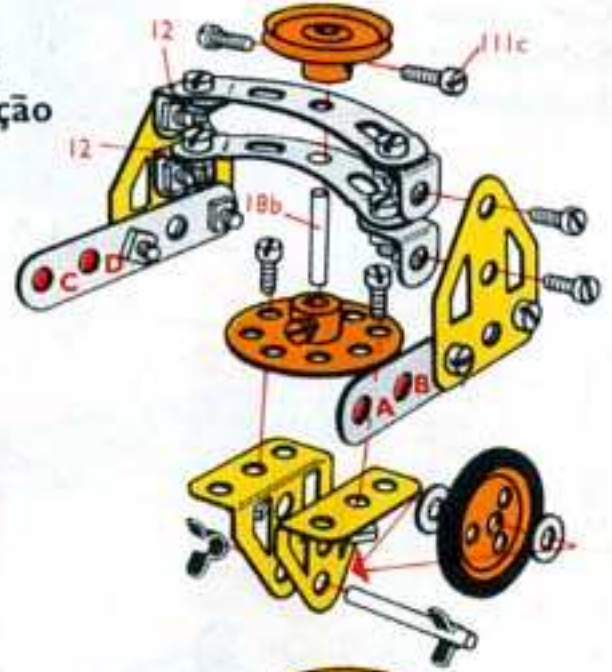

4-	2	1-	19a	36-	37b	2-	111c
4-	5	4-	22	8-	38	2-	126
3-	10	1-	22a	1-	40	2-	126a
6-	12	1-	24	2-	48a	2-	142c
2-	16	6-	35	1-	52	1-	155
1-	18b	35-	37a	2-	90a	2-	189

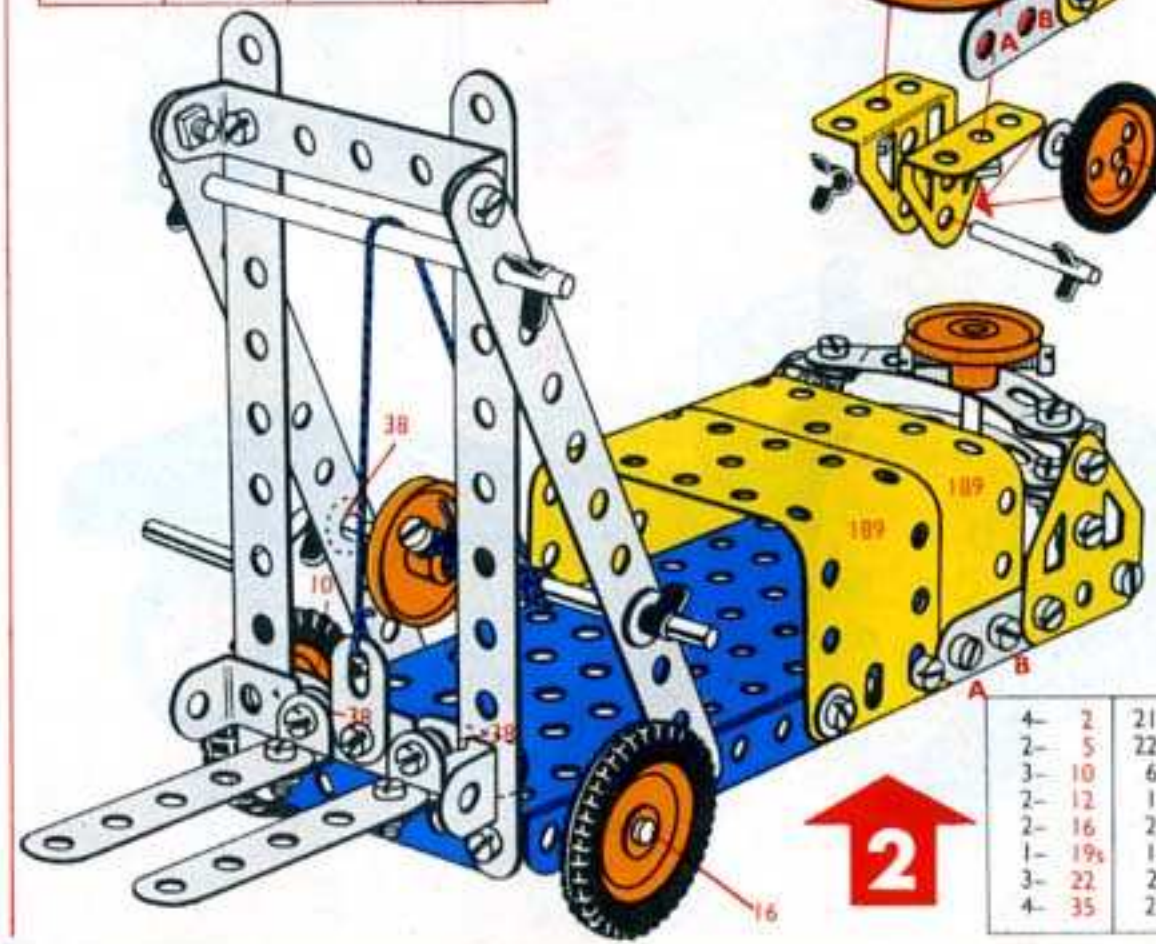

4-	2	21-	37a
2-	5	22-	37b
3-	10	6-	38
2-	12	1-	40
2-	16	2-	48a
1-	19a	1-	52
3-	22	2-	142c
4-	35	2-	189

**2.13.**  
**Station Truck**  
**Stationstruck**  
**Camionette**  
**Carrello per stazione**  
**Kombi**  
**Camioneta**  
**Camião de transporte**  
**Stasjons-truck**

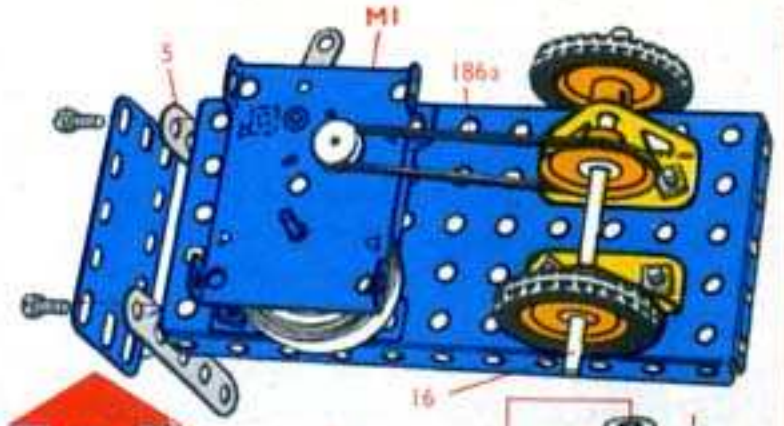

2- 5	2-126
1- 16	2-142c
3- 22	*1-186a
8- 37a	1-194
8- 37b	
1- 52	

2- 2	1- 48a
1- 5	1- 90a
3- 12	2-111c
1- 22	1-155
20- 37a	1-189
18- 37b	1-194
5- 38	

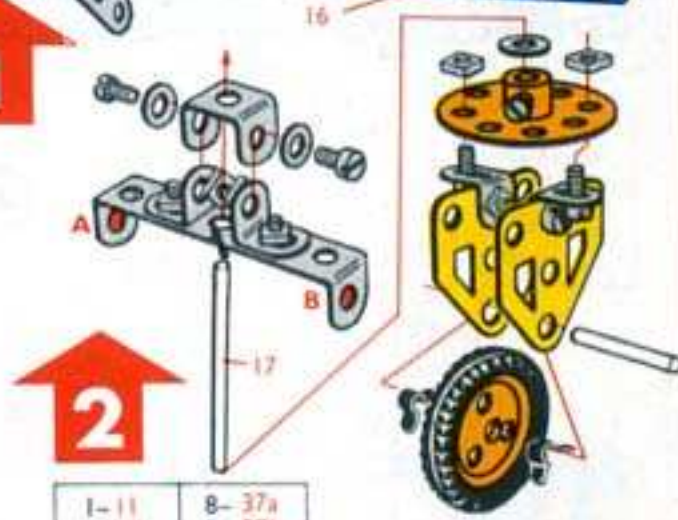

1-11	8- 37a
4-12	8- 37b
1-17	3- 38
1-18b	1- 48a
1-22a	2-126a
1-24	1-142c
2-35	

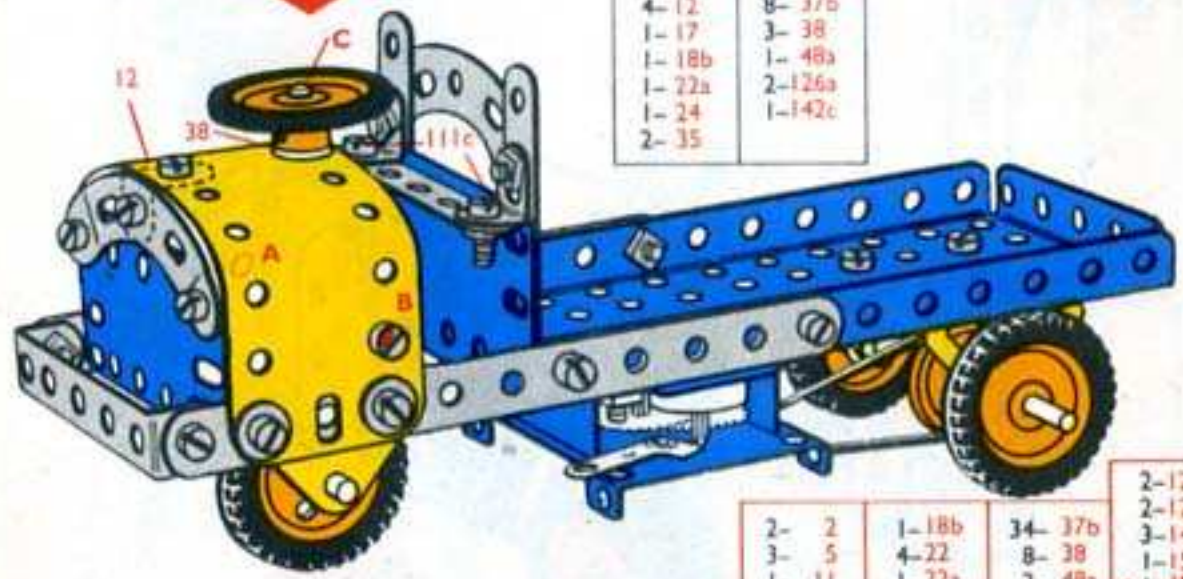

2- 2	1-18b	34- 37b	2-126
3- 5	4-22	8- 38	2-126a
1- 11	1-22a	2- 48a	3-142c
7- 12	1-24	1- 52	1-155
1- 16	2-35	1- 90a	*1-186a
1- 17	36- 37a	2-111c	1-189
			2-194
			*1-M1

\*Not included in set

**2.14.**  
**Drilling Machine**  
**Boormachine**  
**Foreuse**  
**Foratrice**  
**Bohrmaschine**  
**Borrmaskin**  
**Máquina de taladrar**  
**Engenho de furar**  
**Boremaskin**

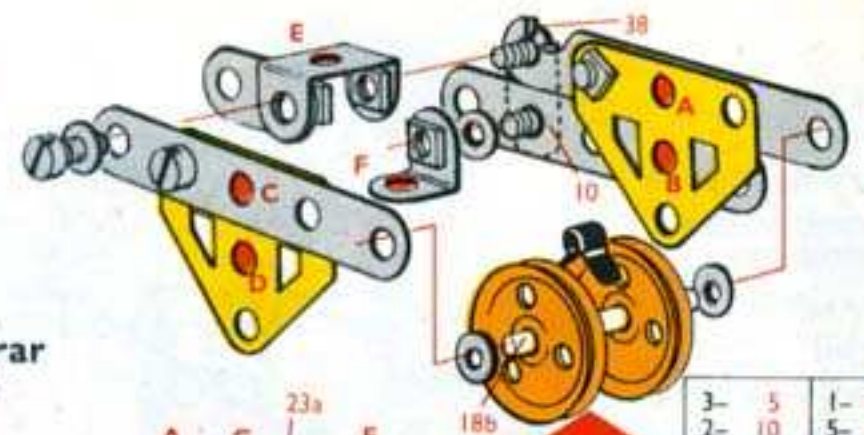

3- 5	1- 35
2- 10	5- 37a
1- 11	5- 37b
1- 12	5- 38
1- 18b	2- 126a
2- 22a	

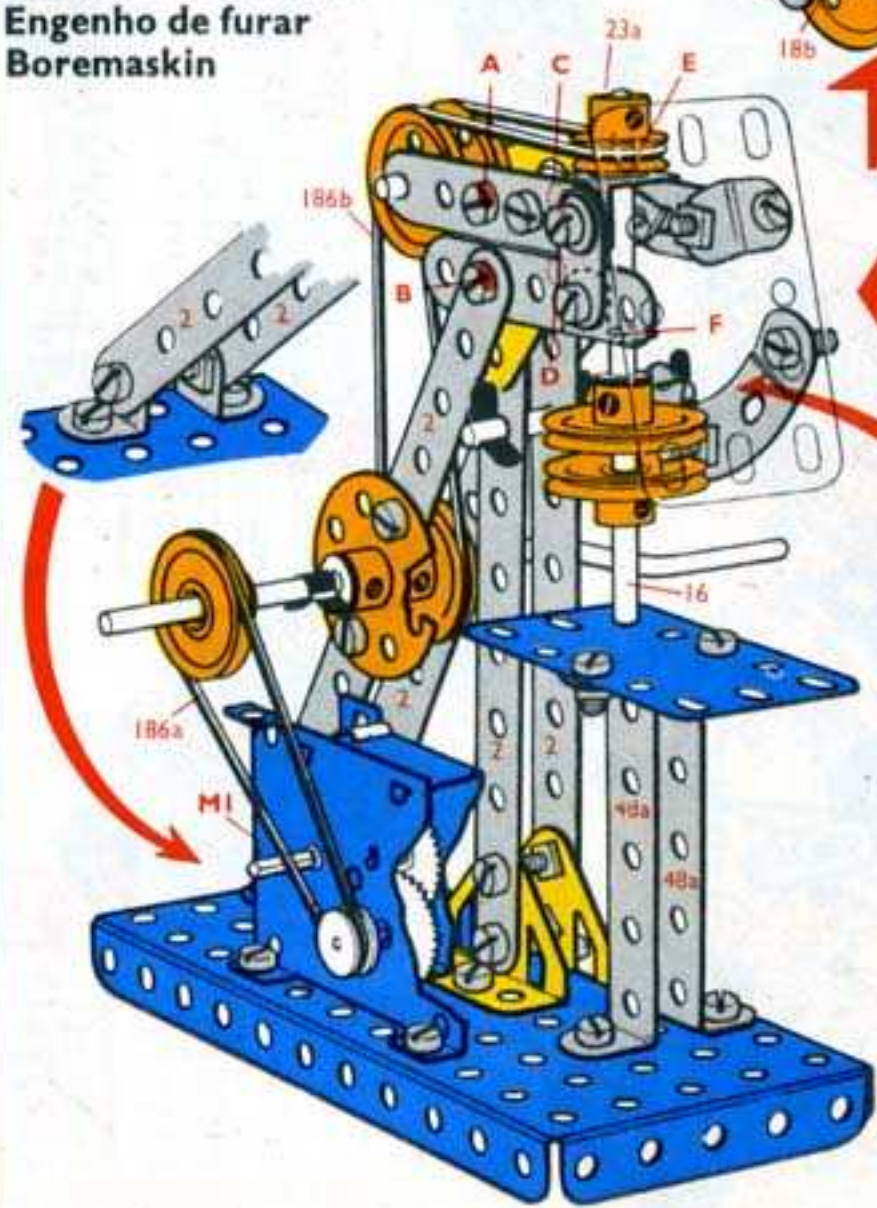

4- 2	2- 48a
3- 12	1- 52
1- 16	1- 90a
1- 17	2-111c
1- 19s	1-125
4- 22	2-126
*1-23a	*1-186a
1-24	*1-186b
4- 35	1-193
28- 37a	1-194
25- 37b	
3- 38	

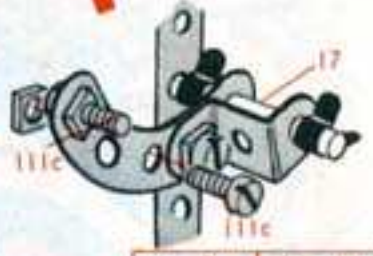

4- 2	30- 37b
3- 5	8- 38
2- 10	2- 48a
1- 11	1- 52
4- 12	1- 90a
1- 16	2-111c
1- 17	1-125
1- 18b	2-126
1- 19s	2-126a
4- 22	*1-186a
2- 22a	*1-186b
*1-23a	1-193
1-24	1-194
5- 35	*1-M1
33- 37a	

\*Not included in set



### 2.15. Go Kart Skelter Kart Go-kart 'Go Kart'

2-	2	29-	37a
4-	5	17-	37b
3-	10	6-	38
1-	11	2-	48a
2-	12	1-	90a
1-	16	4-	111c
2-	22a	2-	126
1-	24	2-	126a
4-	35	2-	142c

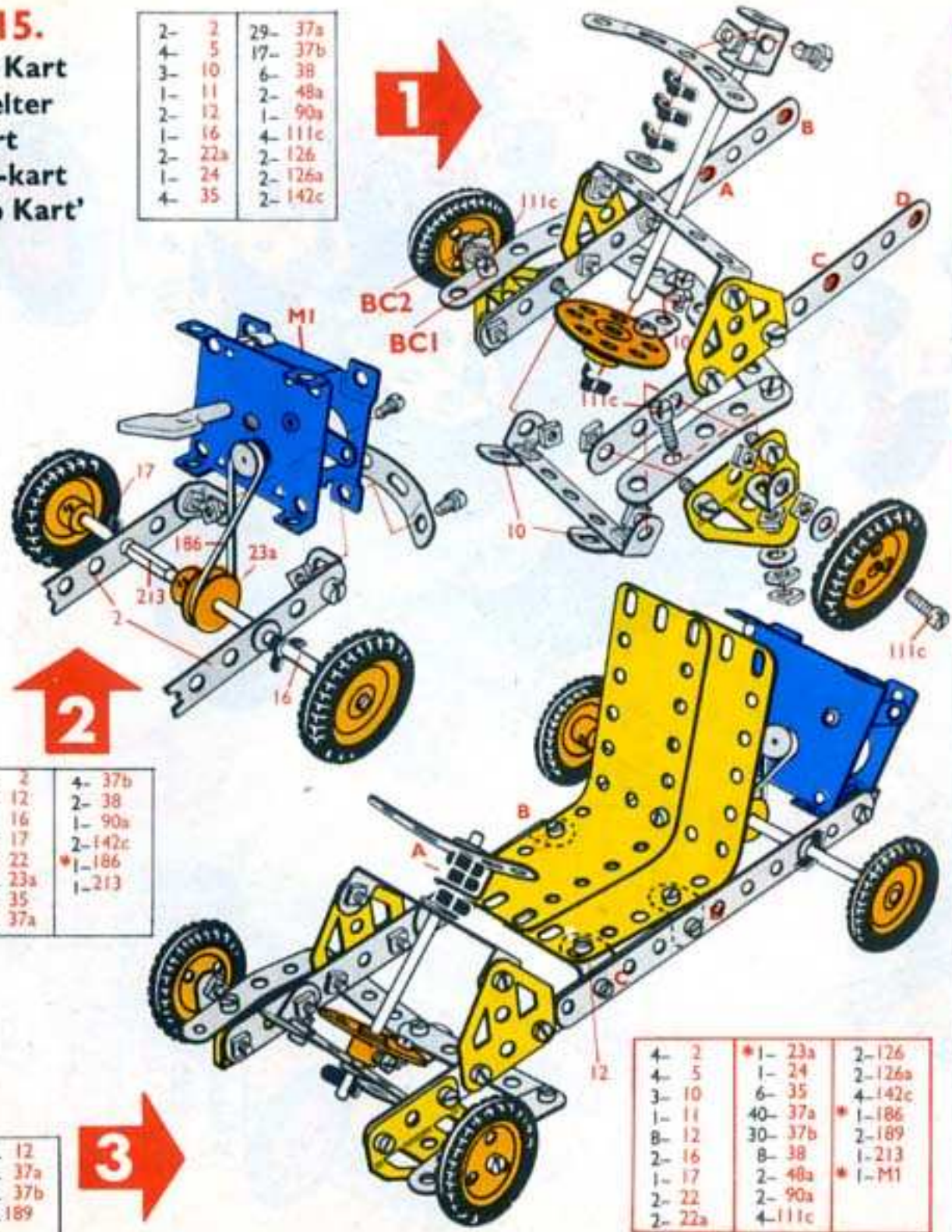

2-	2	4-	37b
2-	12	2-	38
1-	16	1-	90a
1-	17	2-	142c
2-	22	*1-	186
*1-	23a	1-	213
2-	35		
4-	37a		

4-	12
7-	37a
9-	37b
2-	189



4-	2	*1-	23a	2-	126
4-	5	1-	24	2-	126a
3-	10	6-	35	4-	142c
1-	11	40-	37a	*1-	186
8-	12	30-	37b	2-	189
2-	16	8-	38	1-	213
1-	17	2-	48a	*1-	M1
2-	22	2-	90a		
2-	22a	4-	111c		

\* Not included in set

### 2.16. Jeep

4-	2
5-	12
1-	22a
13-	37a
12-	37b
6-	38
1-	48a
1-	111c
1-	155
1-	189
1-	194



4-	2	2-	48a
2-	5	1-	52
3-	10	1-	111c
7-	12	1-	125
2-	16	2-	126
1-	17	1-	126a
4-	22	4-	142c
2-	22a	2-	155
3-	35	2-	189
34-	37a	1-	193
33-	37b	1-	194
8-	38		

1-	5
1-	17
1-	22a
3-	35
4-	37a
4-	37b
1-	52
1-	125
2-	126
1-	155

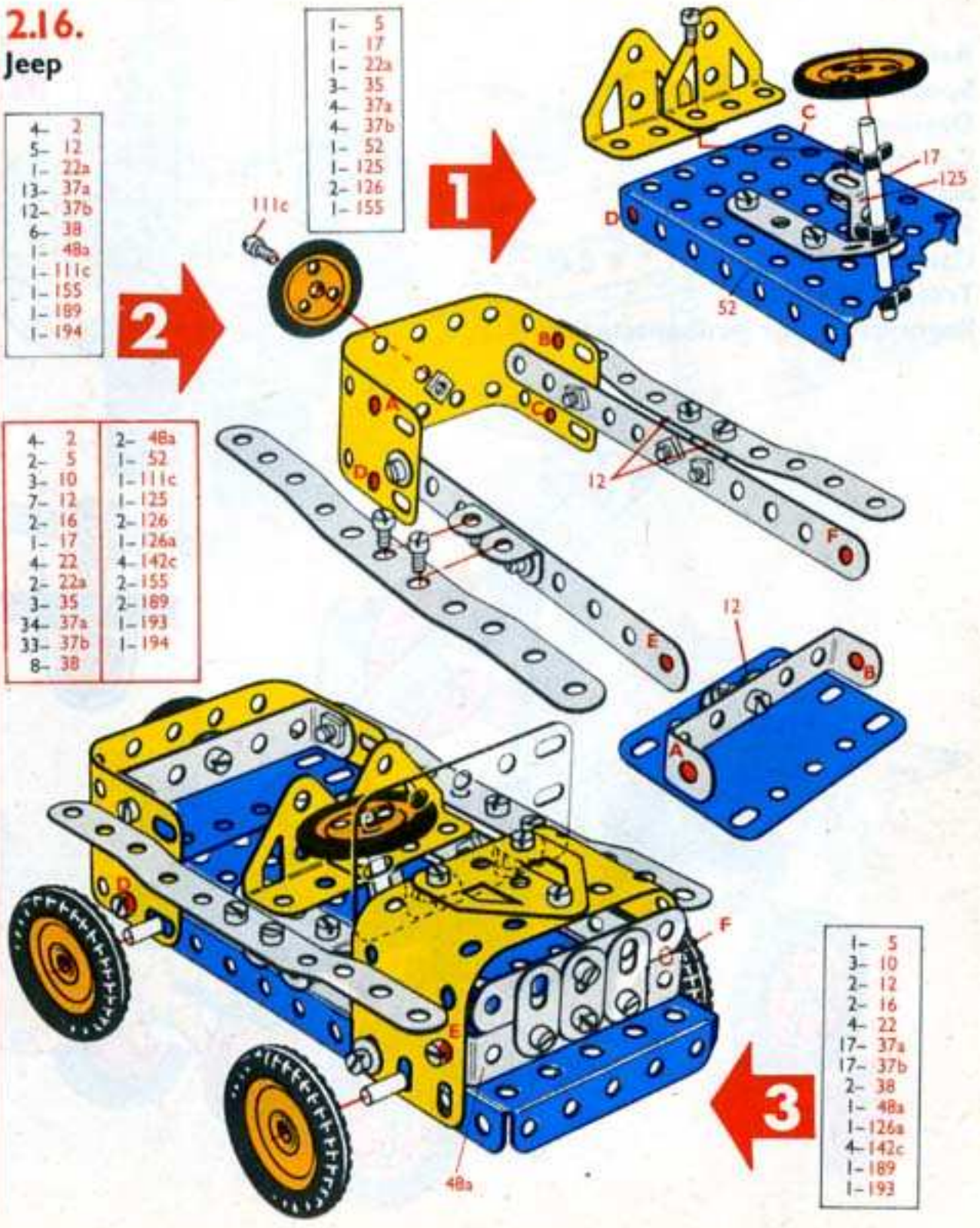

1-	5
3-	10
2-	12
2-	16
4-	22
17-	37a
17-	37b
2-	38
1-	48a
1-	126a
4-	142c
1-	189
1-	193

### 3.1.

Rail Trolley  
 Spoorwagenthe  
 Draisine  
 Carrello su binario  
 Schienen-Trolley  
 Rälsvagn  
 Carretilla de vía  
 Trólei ferroviário  
 Bagasjevogn for jernbanestasjon

3-	5	6-	38
2-	12	1-	52
2-	17	2-	90a
1-	18b	2-	111c
4-	22	1-	125
2-	22a	2-	126
1-	35	2-	126a
25-	37a	4-	142c
19-	37b	1-	176

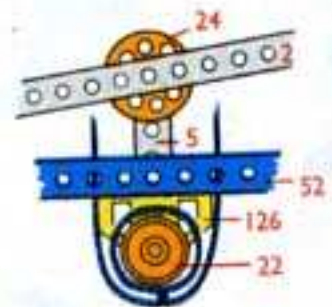
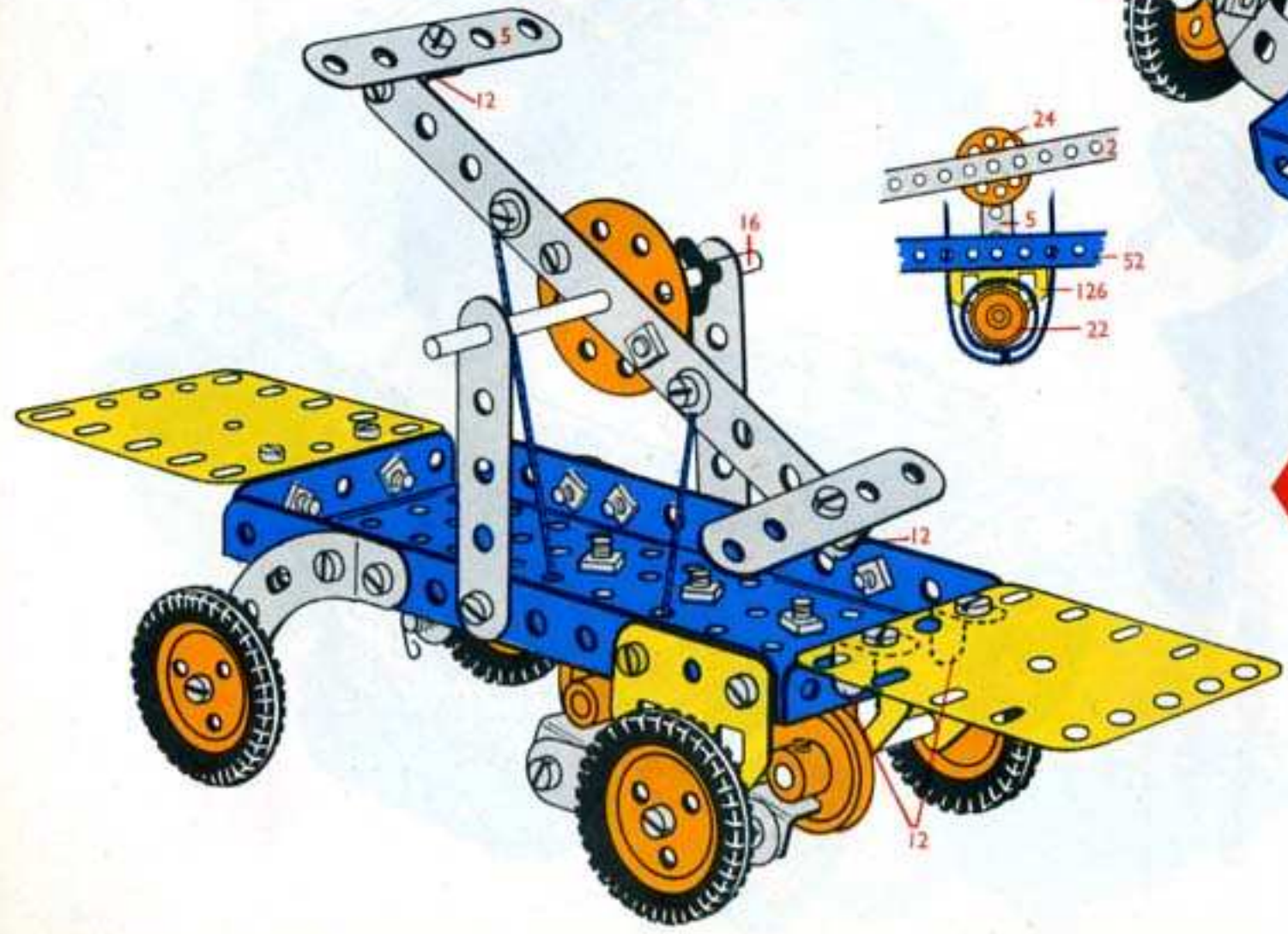
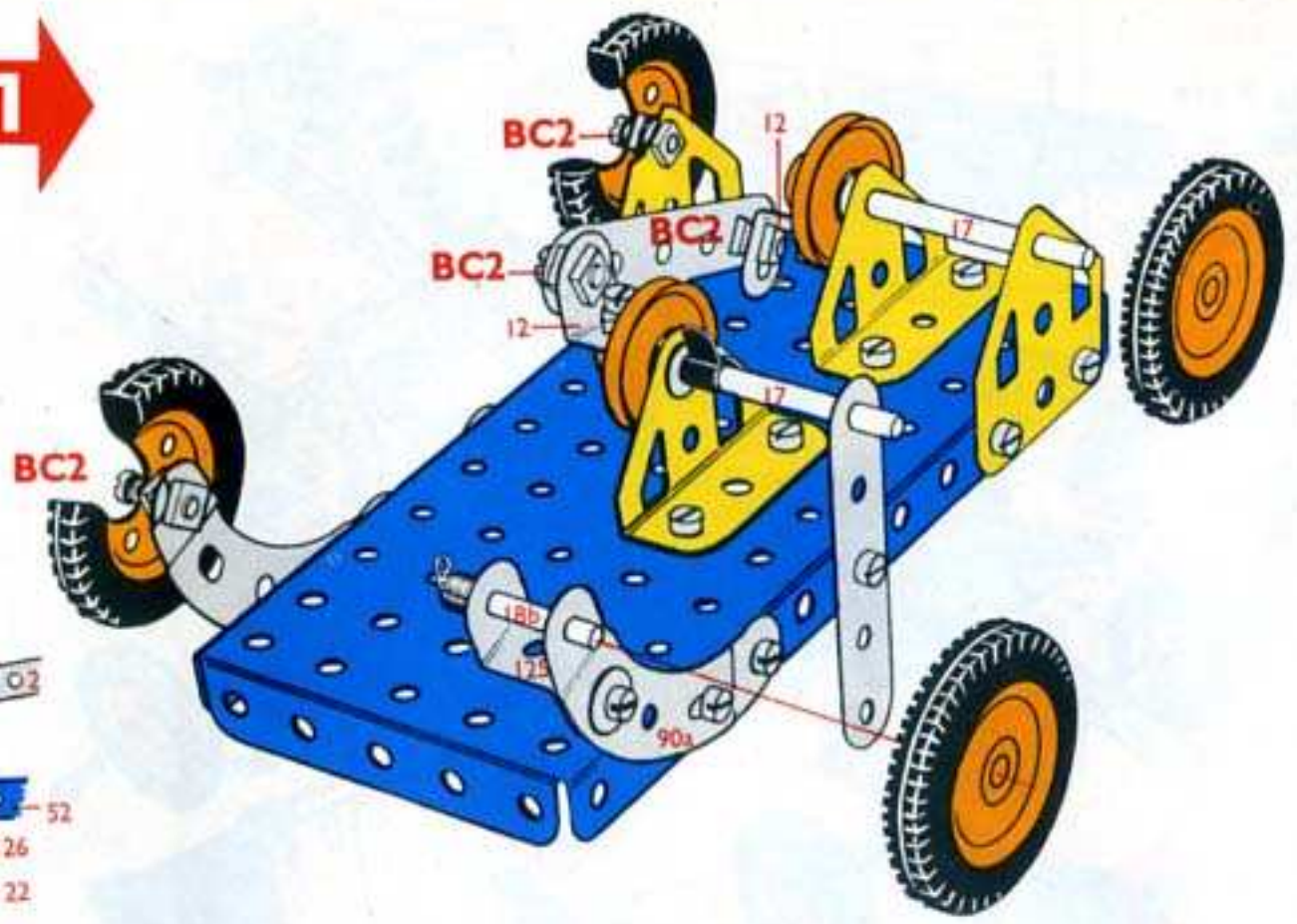

1-	2
3-	5
6-	12
1-	16
1-	24
2-	35
17-	37a
17-	37b
4-	38
1-	40
2-	190

1-	2	10-	38
6-	5	1-	40
8-	12	1-	52
1-	16	2-	90a
2-	17	2-	111c
1-	18b	1-	125
4-	22	2-	126
2-	22a	2-	126a
1-	24	4-	142c
3-	35	1-	176
42-	37a	2-	190
36-	37b		

### 3.2.

Shipyards Crane  
 Scheepswerfkraan  
 Grue de chantier naval  
 Gru per cantiere costruzioni navali  
 Werftkran  
 Varvskran  
 Grúa de astillero  
 Guindaste de estaleiro naval  
 Skipsverft-kran

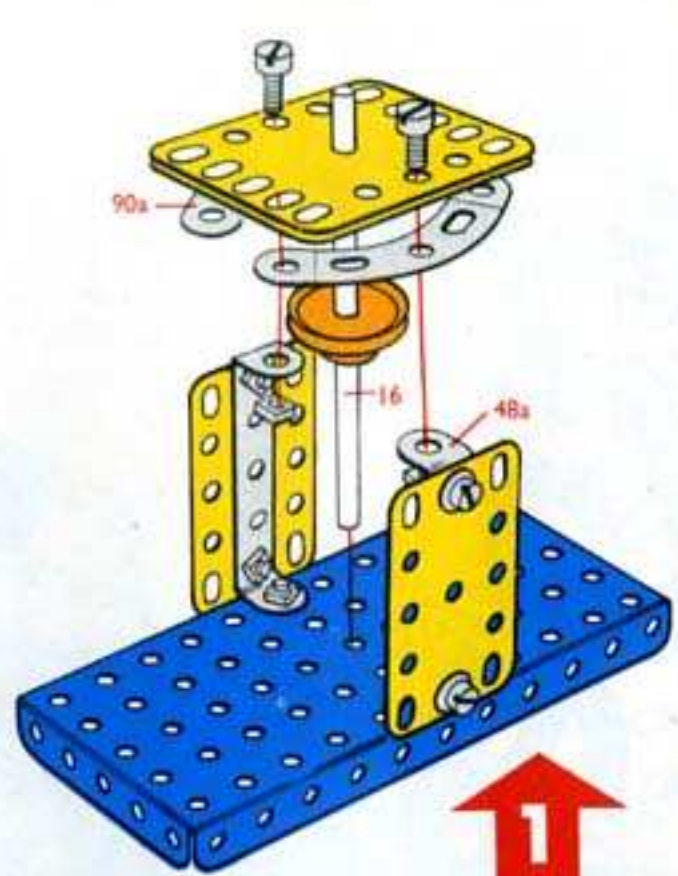

- |    |     |
|----|-----|
| 1- | 22  |
| 8- | 37a |
| 8- | 37b |
| 4- | 38  |
| 2- | 48a |
| 1- | 52  |
| 2- | 90a |
| 2- | 188 |
| 2- | 190 |

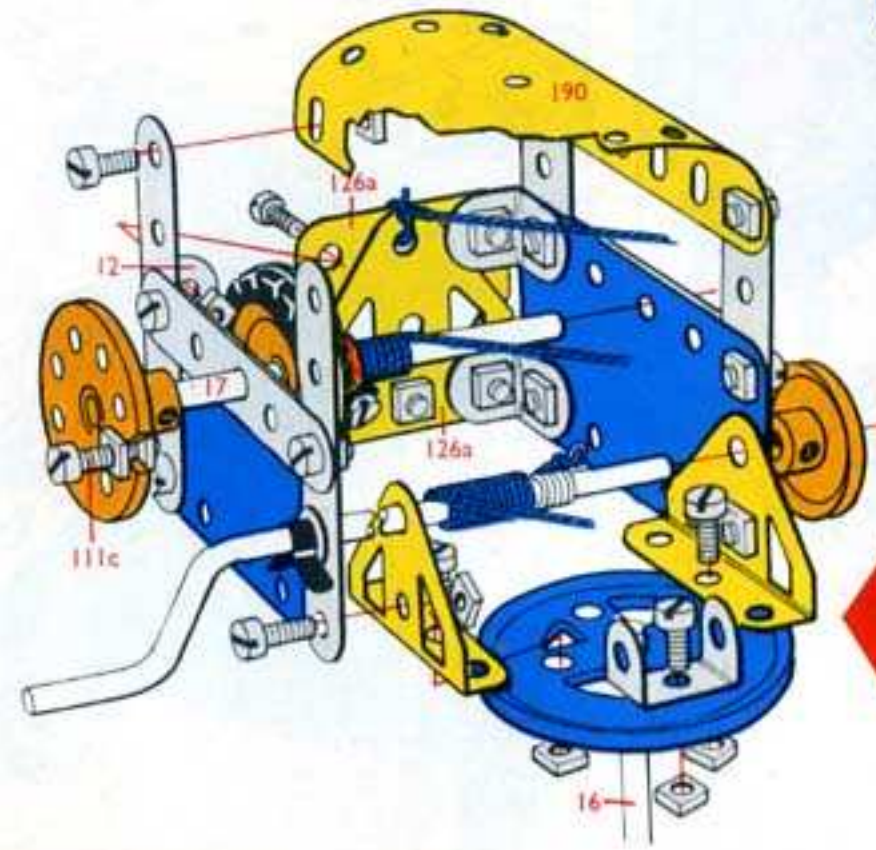

- |     |     |     |      |
|-----|-----|-----|------|
| 6-  | 5   | 21- | 37b  |
| 1-  | 11  | 3-  | 38   |
| 4-  | 12  | 1-  | 40   |
| 1-  | 16  | 1-  | 111c |
| 1-  | 17  | 2-  | 126  |
| 1-  | 19s | 2-  | 126a |
| 1-  | 20a | 1-  | 142c |
| 2-  | 22  | 1-  | 176  |
| 1-  | 24  | 2-  | 194  |
| 1-  | 35  | 1-  | 199  |
| 23- | 37a |     |      |

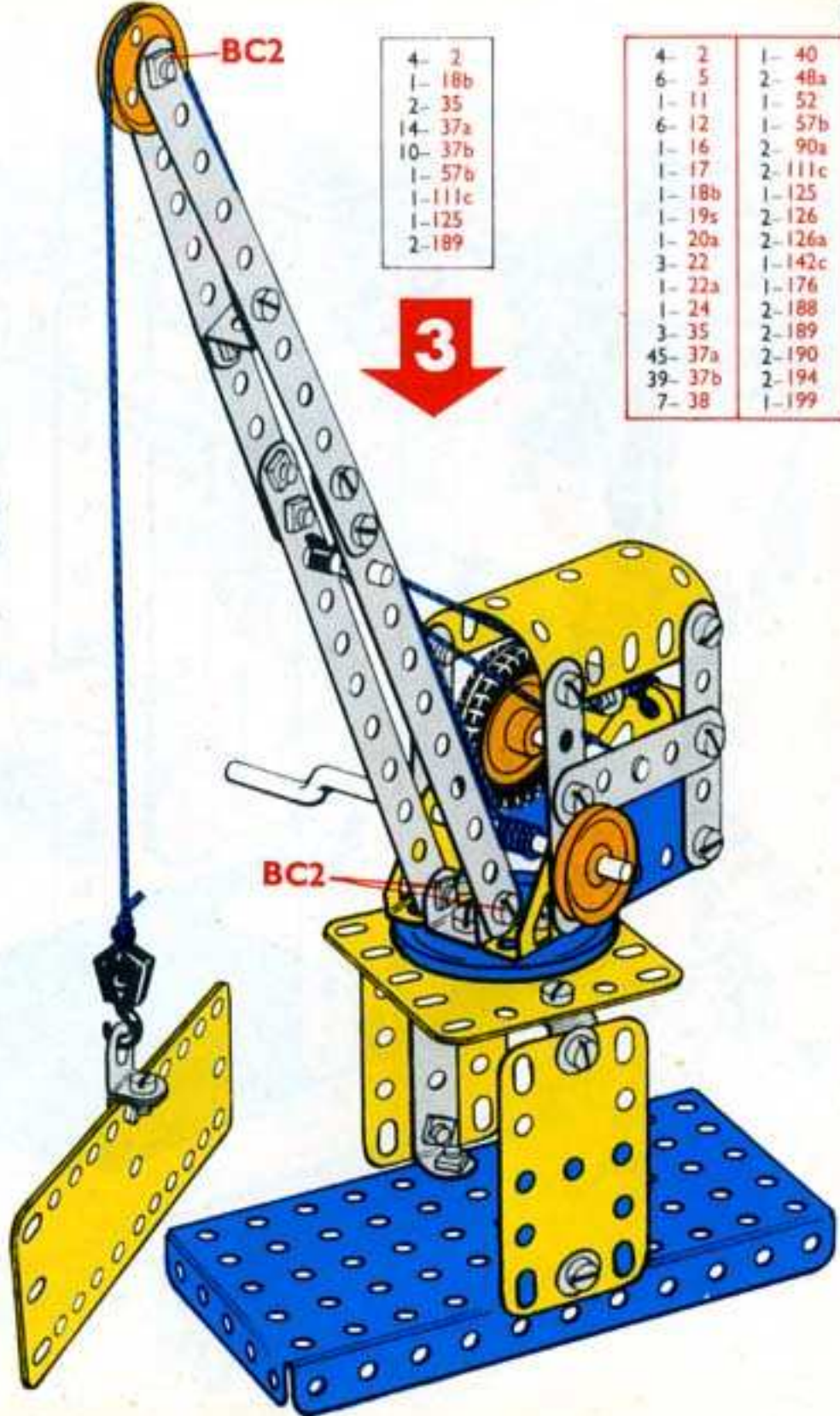

- |     |      |
|-----|------|
| 4-  | 2    |
| 1-  | 18b  |
| 2-  | 35   |
| 14- | 37a  |
| 10- | 37b  |
| 1-  | 57b  |
| 1-  | 111c |
| 1-  | 125  |
| 2-  | 189  |

- |     |     |    |      |
|-----|-----|----|------|
| 4-  | 2   | 1- | 40   |
| 6-  | 5   | 2- | 48a  |
| 1-  | 11  | 1- | 52   |
| 6-  | 12  | 1- | 57b  |
| 1-  | 16  | 2- | 90a  |
| 1-  | 17  | 2- | 111c |
| 1-  | 18b | 1- | 125  |
| 1-  | 19s | 2- | 126  |
| 1-  | 20a | 2- | 126a |
| 3-  | 22  | 1- | 142c |
| 1-  | 22a | 1- | 176  |
| 1-  | 24  | 2- | 188  |
| 3-  | 35  | 2- | 189  |
| 45- | 37a | 2- | 190  |
| 39- | 37b | 2- | 194  |
| 7-  | 38  | 1- | 199  |

**3.3.**  
**Band Saw**  
**Lintzaag**  
**Scie à bande**  
**Sega a nastro**  
**Bandsäge**  
**Bandsåg**  
**Sierra de cinta**  
**Serra de fita**  
**Bandsag**

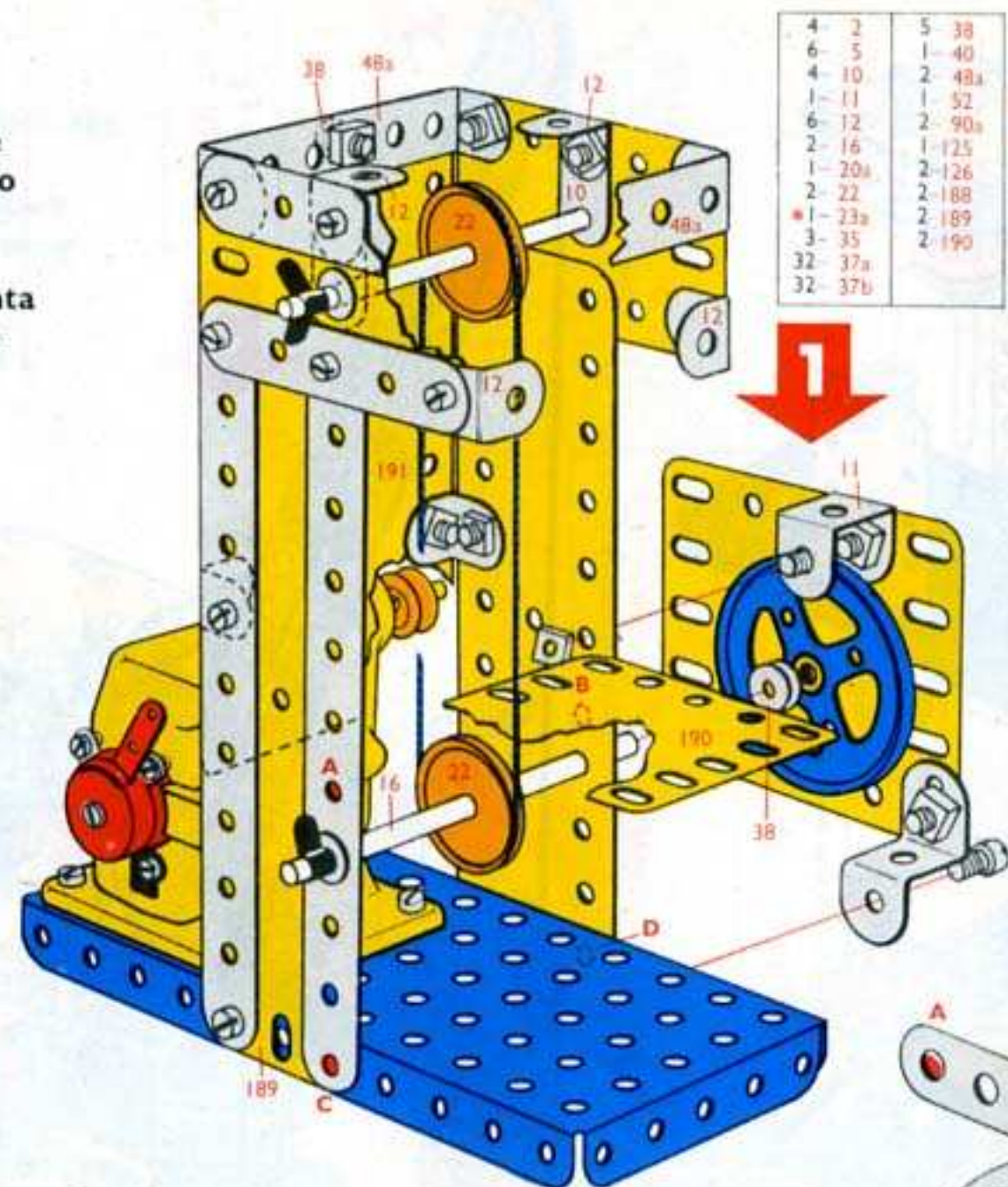

4	2	5	38
6	5	1	40
4	10	2	48a
1	11	1	52
6	12	2	90a
2	16	1	125
1	20a	2	126
2	22	2	188
*1	23a	2	189
3	35	2	190
32	37a		
32	37b		

10	37a
10	37b
5	38
*1	186a
1	191
1	194
1	194a

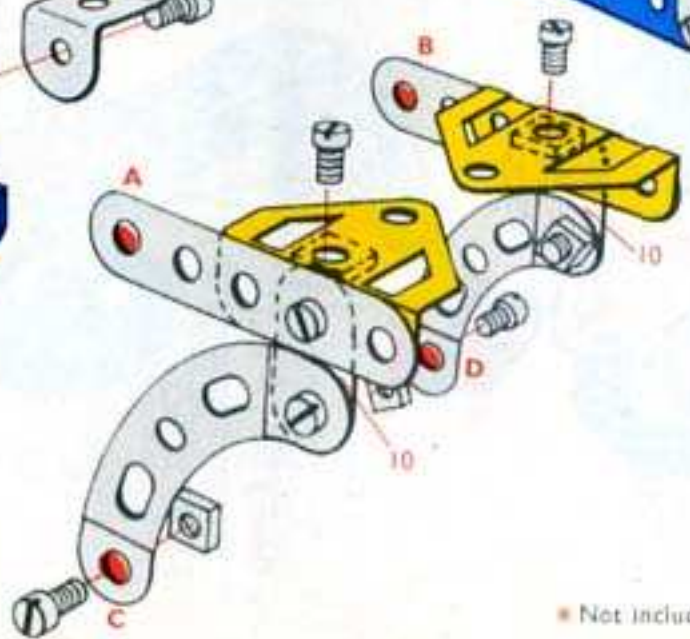
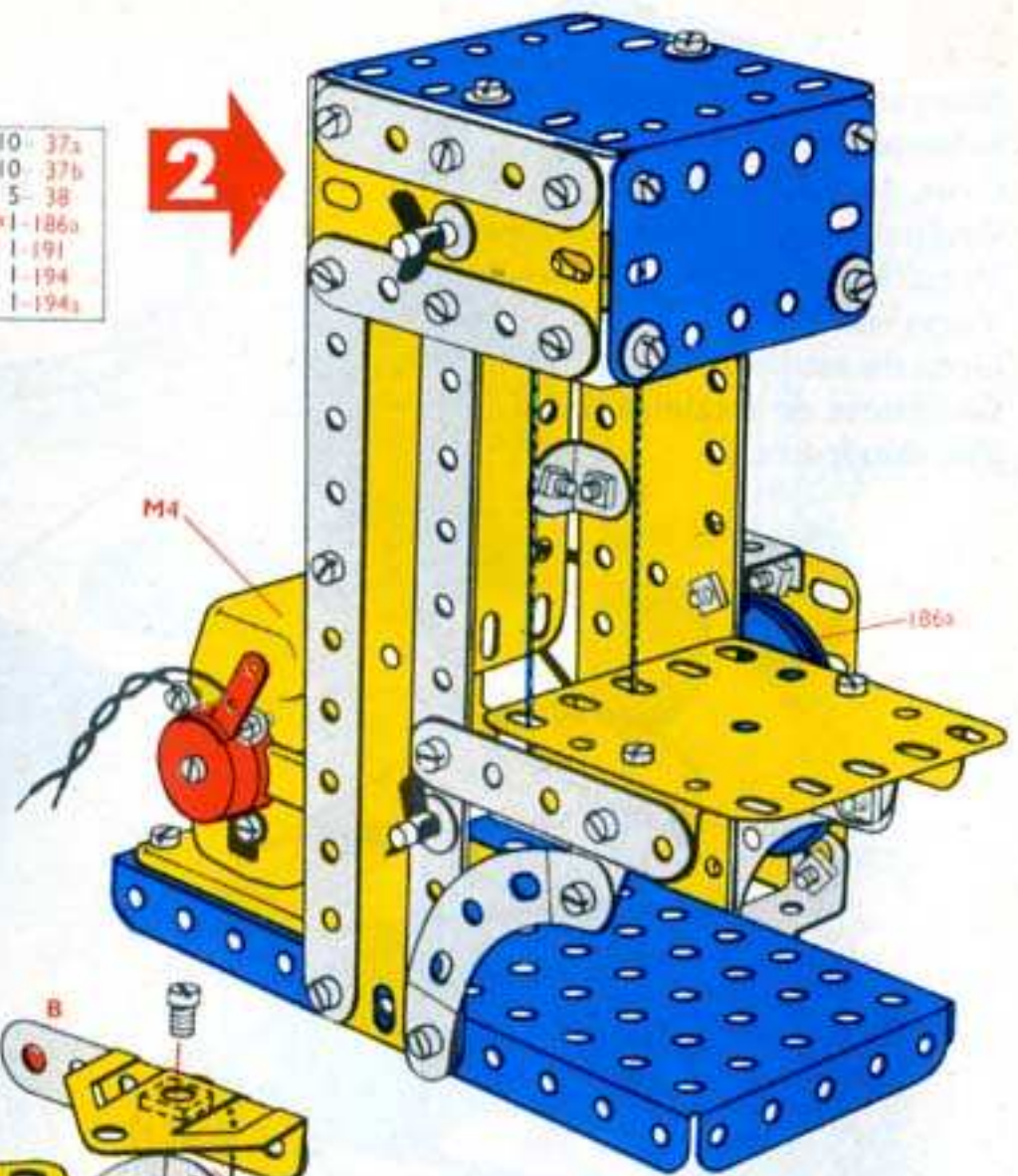

4	2	2	48a
6	5	1	52
4	10	2	90a
1	11	1	125
6	12	2	126
2	16	*1	186a
1	20a	2	188
2	22	2	189
*1	23a	2	190
3	35	1	191
42	37a	1	194
42	37b	1	194a
10	38	*1	111
1	40		

\* Not included in set No 3

**3.4.**

**Tilt Cab Tipping Wagon**  
**Kipwagen met kantelbare cabine**  
**Camion basculant avec cabine inclinable**  
**Ribaltabile a cabina inclinabile**  
**Kippwagen**  
**Tippvagn med hytt**  
**Camión-volquete con cabina inclinable**  
**Vagão basculante**  
**Tippvagn med førerhus som kan vippes opp**

4- 2	1- 52
6- 5	2- 90a
3- 10	2- 111c
1- 11	1- 125
8- 12	2- 126
2- 16	2- 126a
1- 17	4- 142c
4- 22	1- 155
1- 22a	*1- 186b
*1- 23a	2- 188
4- 35	2- 189
55- 37a	2- 190
49- 37b	1- 193
10- 38	2- 194
2- 48a	*1- M1

\* Not included in set



4- 2
3- 10
1- 11
4- 12
2- 16
4- 22
1- 22a
*1- 23a
2- 35
18- 37a
16- 37b
4- 38
1- 125
1- 126a
4- 142c
1- 155
*1- 186b

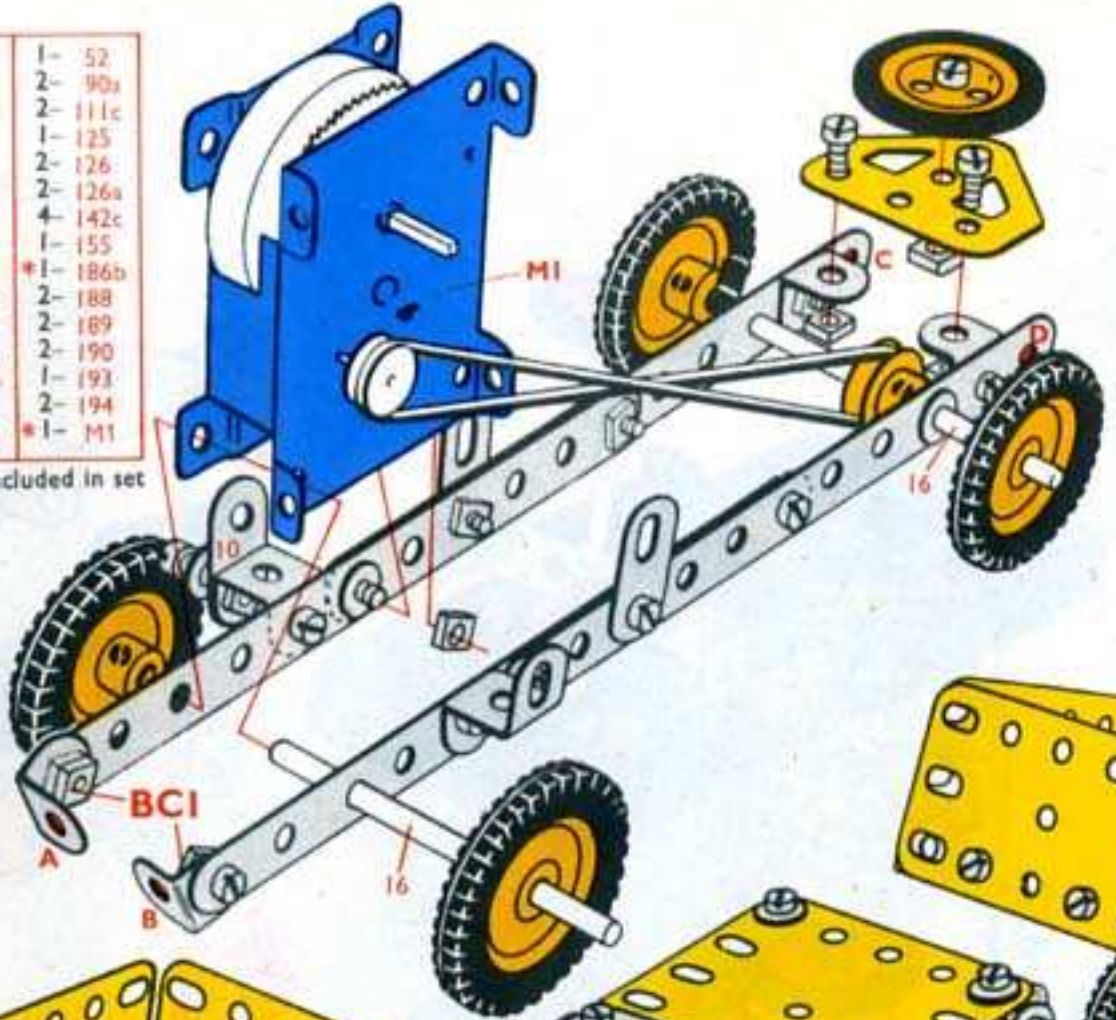

5- 5
4- 12
19- 37a
19- 37b
4- 38
1- 48a
2- 90a
1- 126a
2- 190
1- 193
2- 194

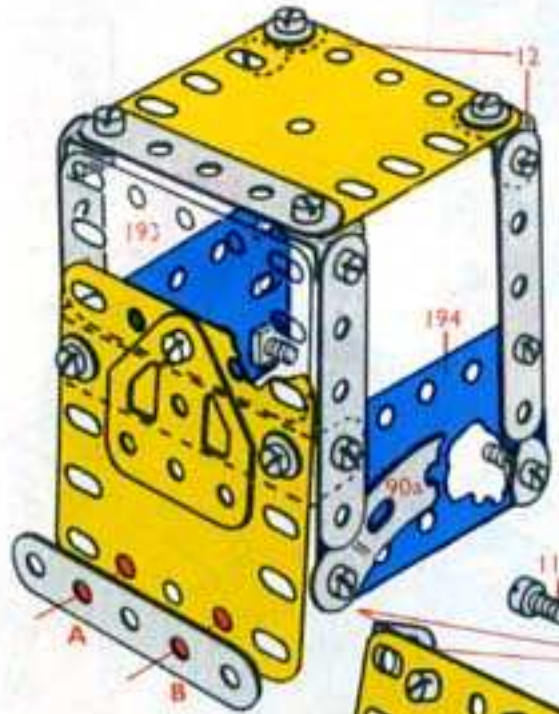

16- 37a
12- 37b
2- 38
1- 48a
1- 52
2- 111c
2- 126
2- 188
2- 189

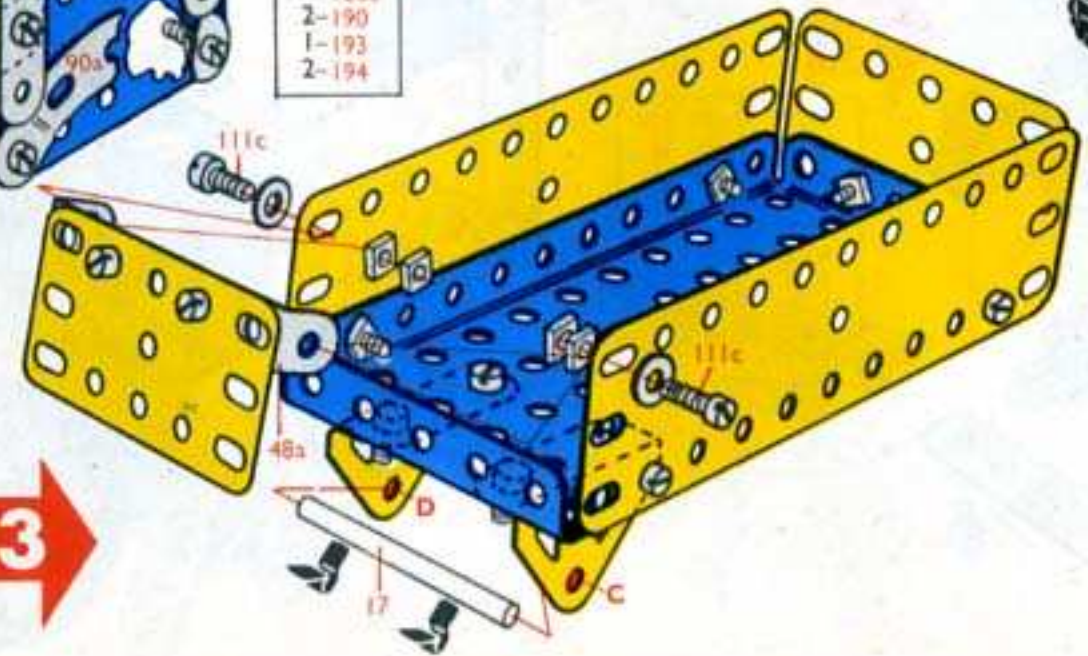

1- 5
1- 17
2- 35
2- 37a
2- 37b

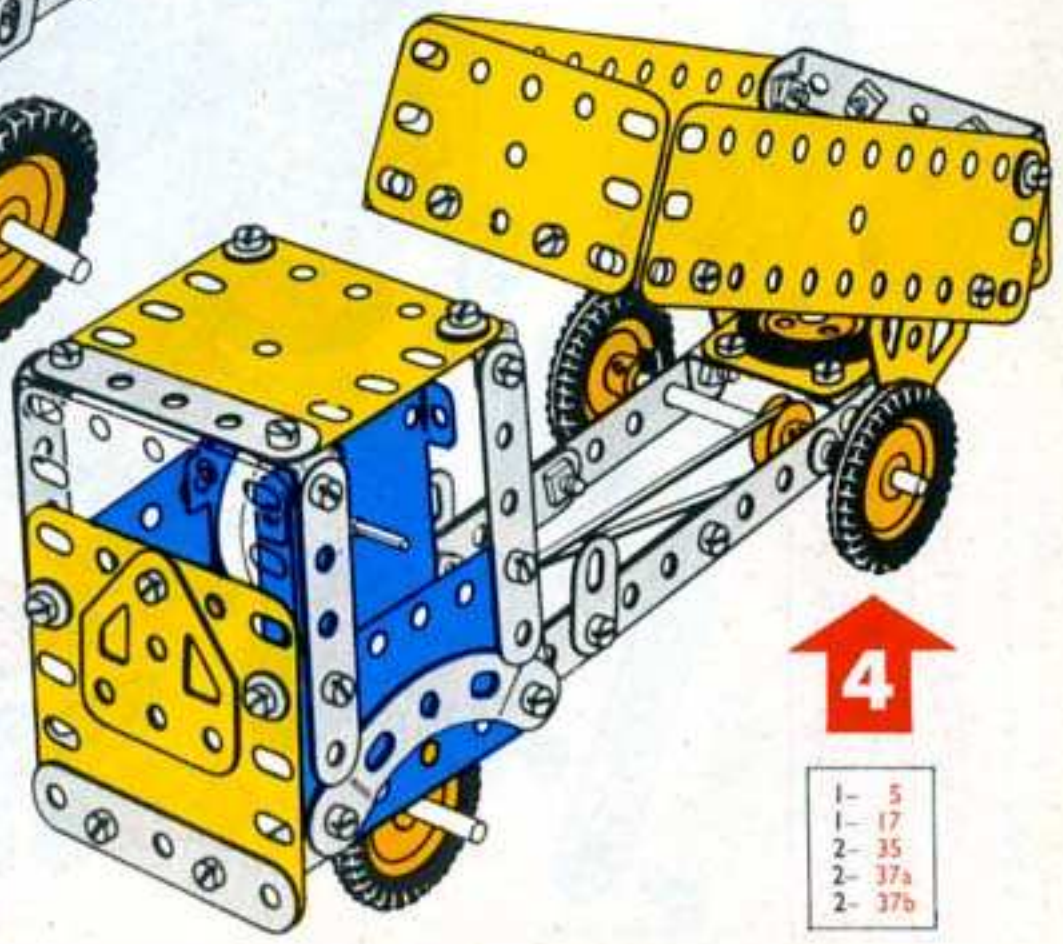

### 3.5.

**Baggage Truck**  
**Bagagewagen**  
**Chariot à bagages**  
**Carrello portabagagli**  
**Gepäckwagen**  
**Gagagetruck**  
**Carretilla de andén**  
**Camioneta de bagagem**  
**Bagasjevogn**

6 - 5	1 - 52
3 - 10	2 - 90a
1 - 11	4 - 111c
8 - 12	1 - 125
2 - 16	2 - 126
1 - 17	2 - 126a
1 - 18b	4 - 142c
1 - 20a	2 - 155
4 - 22	* 1 - 186a
2 - 22a	2 - 188
1 - 24	2 - 189
3 - 35	2 - 190
56 - 37a	1 - 191
43 - 37b	2 - 194
10 - 38	1 - 212
2 - 48a	* 1 - M1

\* Not included in set

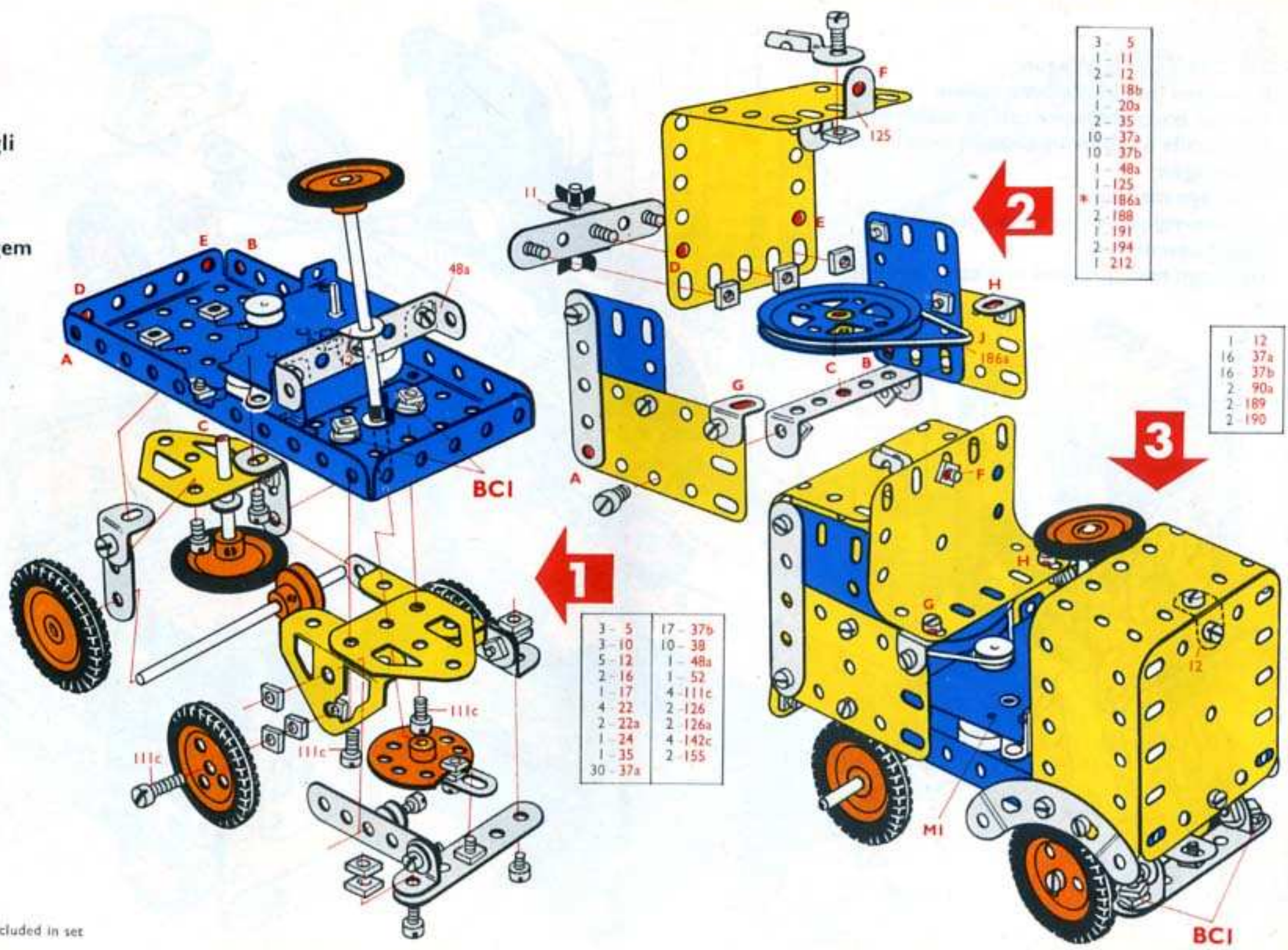

3 - 5
1 - 11
2 - 12
1 - 18b
1 - 20a
2 - 35
10 - 37a
10 - 37b
1 - 48a
1 - 125
* 1 - 186a
2 - 188
1 - 191
2 - 194
1 - 212

1 - 12
16 - 37a
16 - 37b
2 - 90a
2 - 189
2 - 190

3 - 5	17 - 37b
3 - 10	10 - 38
5 - 12	1 - 48a
2 - 16	1 - 52
1 - 17	4 - 111c
4 - 22	2 - 126
2 - 22a	2 - 126a
1 - 24	4 - 142c
1 - 35	2 - 155
30 - 37a	

**3.6.**  
 Excavator  
 Graafmachine  
 Excavateur  
 Scavatore  
 Bagger  
 Grävmaskin  
 Excavadora  
 Escavadora  
 Gravemaskin

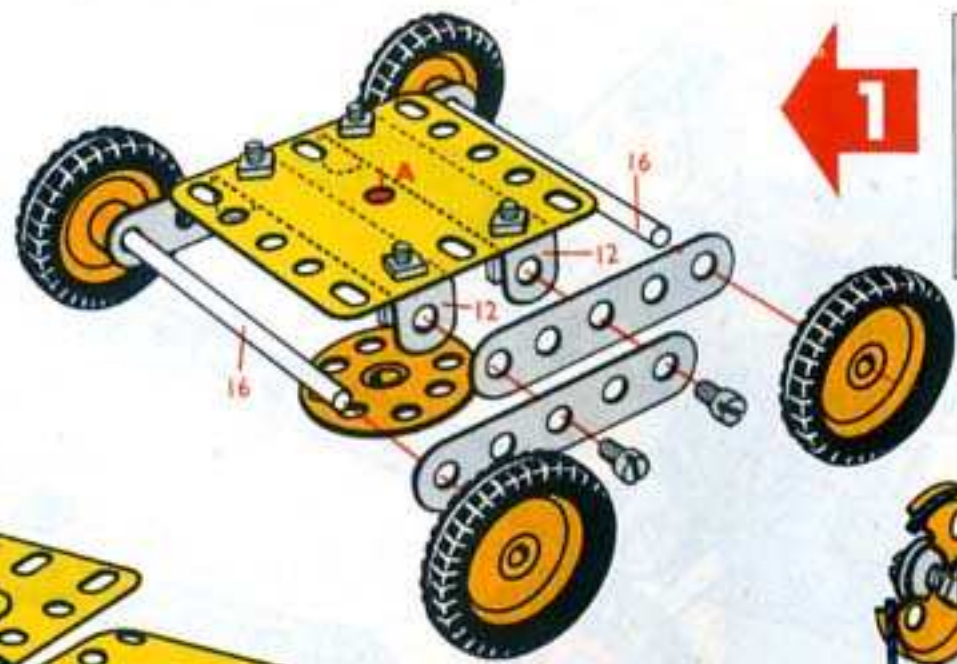

- 4- 5
- 2- 16
- 4- 22
- 1- 24
- 8- 37a
- 8- 37b
- 2- 48a
- 4- 42c
- 1- 190

- 4- 2
- 2- 5
- 1- 10
- 4- 12
- 1- 22a
- 25- 37a
- 16- 37b
- 1- 38
- 1- 40
- 1- 111c
- 2- 126
- 2- 126a

- |        |         |         |
|--------|---------|---------|
| 4- 2   | 1- 24   | 4- 42c  |
| 6- 5   | 6- 35   | 1- 176  |
| 4- 10  | 56- 37a | 2- 188  |
| 1- 11  | 45- 37b | 2- 189  |
| 8- 12  | 10- 38  | 1- 190  |
| 2- 16  | 1- 40   | 1- 191  |
| 2- 17  | 2- 48a  | 2- 193  |
| 1- 18b | 1- 52   | 1- 194  |
| 1- 19a | 2- 90a  | 2- 194a |
| 1- 20a | 4- 111c | 1- 199  |
| 4- 22  | 2- 126  | 1- 213  |
| 2- 22a | 2- 126a |         |

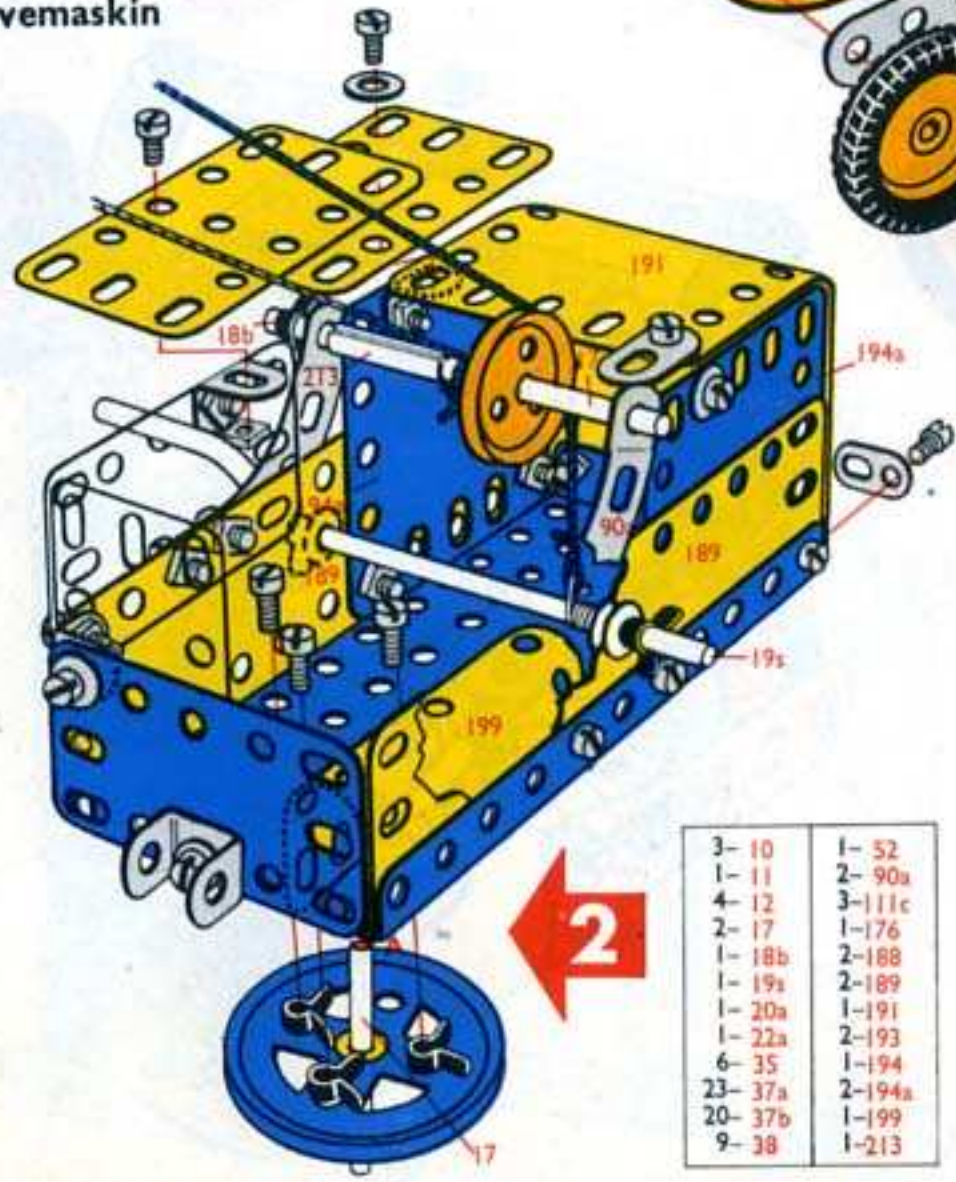

- |         |         |
|---------|---------|
| 3- 10   | 1- 52   |
| 1- 11   | 2- 90a  |
| 4- 12   | 3- 111c |
| 2- 17   | 1- 176  |
| 1- 18b  | 2- 188  |
| 1- 19a  | 2- 189  |
| 1- 20a  | 1- 191  |
| 1- 22a  | 2- 193  |
| 6- 35   | 1- 194  |
| 23- 37a | 2- 194a |
| 20- 37b | 1- 199  |
| 9- 38   | 1- 213  |

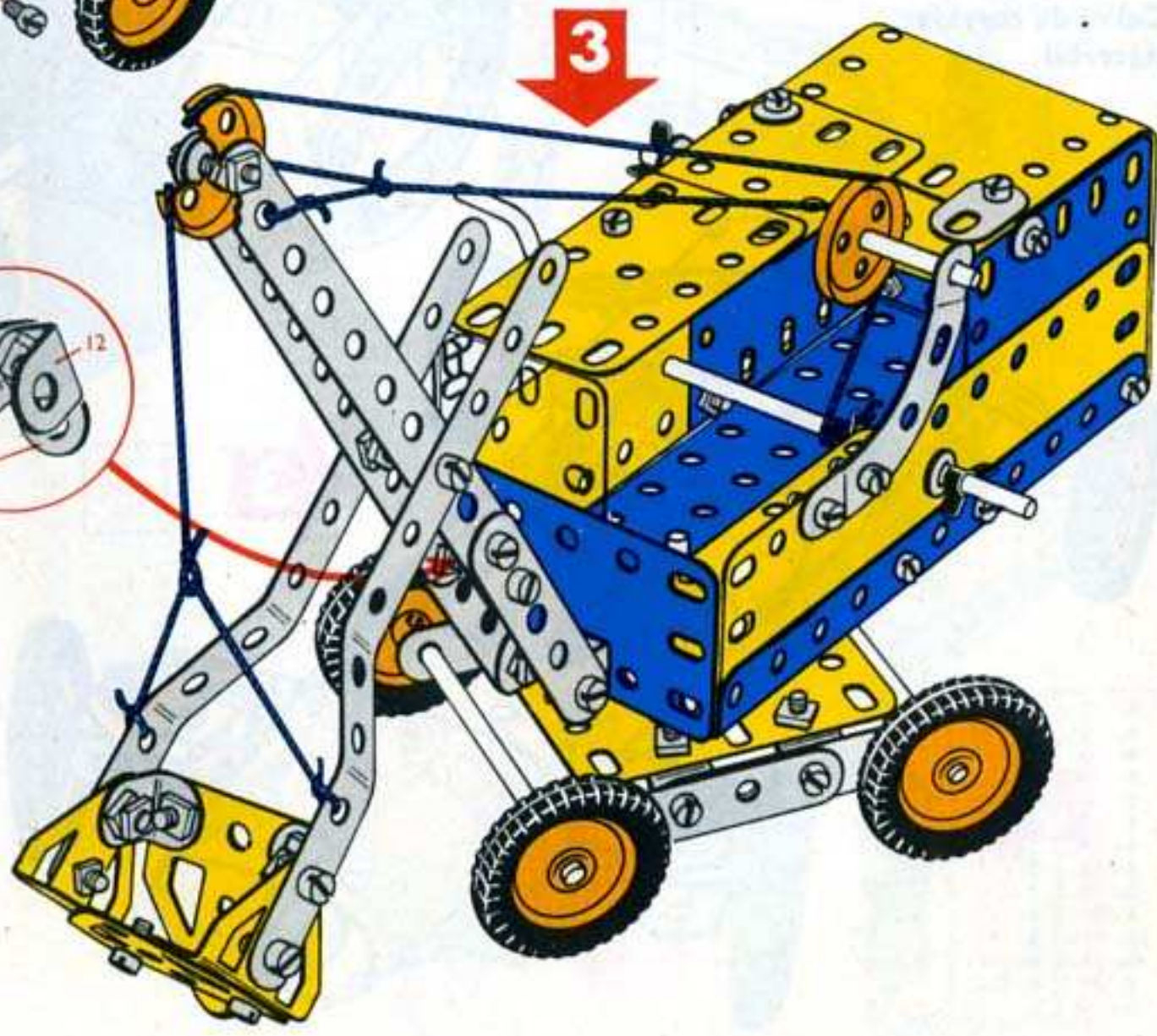
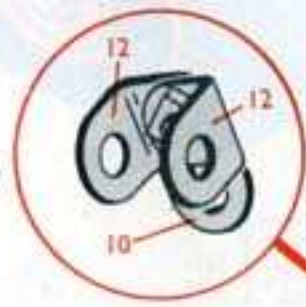

## 3.7.

Racing Car  
 Racewagen  
 Voiture de course  
 Automobile tipo competizione  
 Rennwagen  
 Racerbil  
 Coche de carreras  
 Carro de corridas  
 Racerbil

4-	2
2-	5
4-	10
3-	12
1-	16
1-	17
2-	22
2-	35
23-	37a
23-	37b
2-	38
2-	90a
2-	142c
1-	188
2-	189
1-	199
1-	213

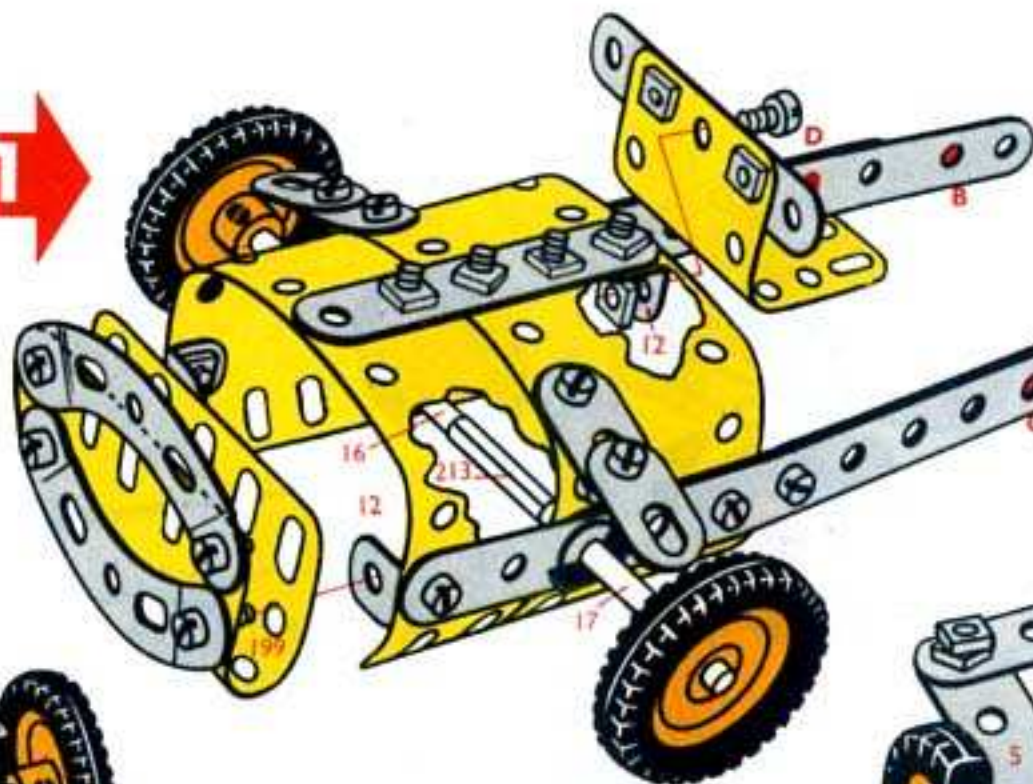

4-	5	2-	48a
5-	12	4-	111c
1-	19s	2-	126
1-	22	2-	126a
2-	22a	2-	142c
1-	35	1-	155
27-	37a	2-	190
15-	37b	1-	191
6-	38		

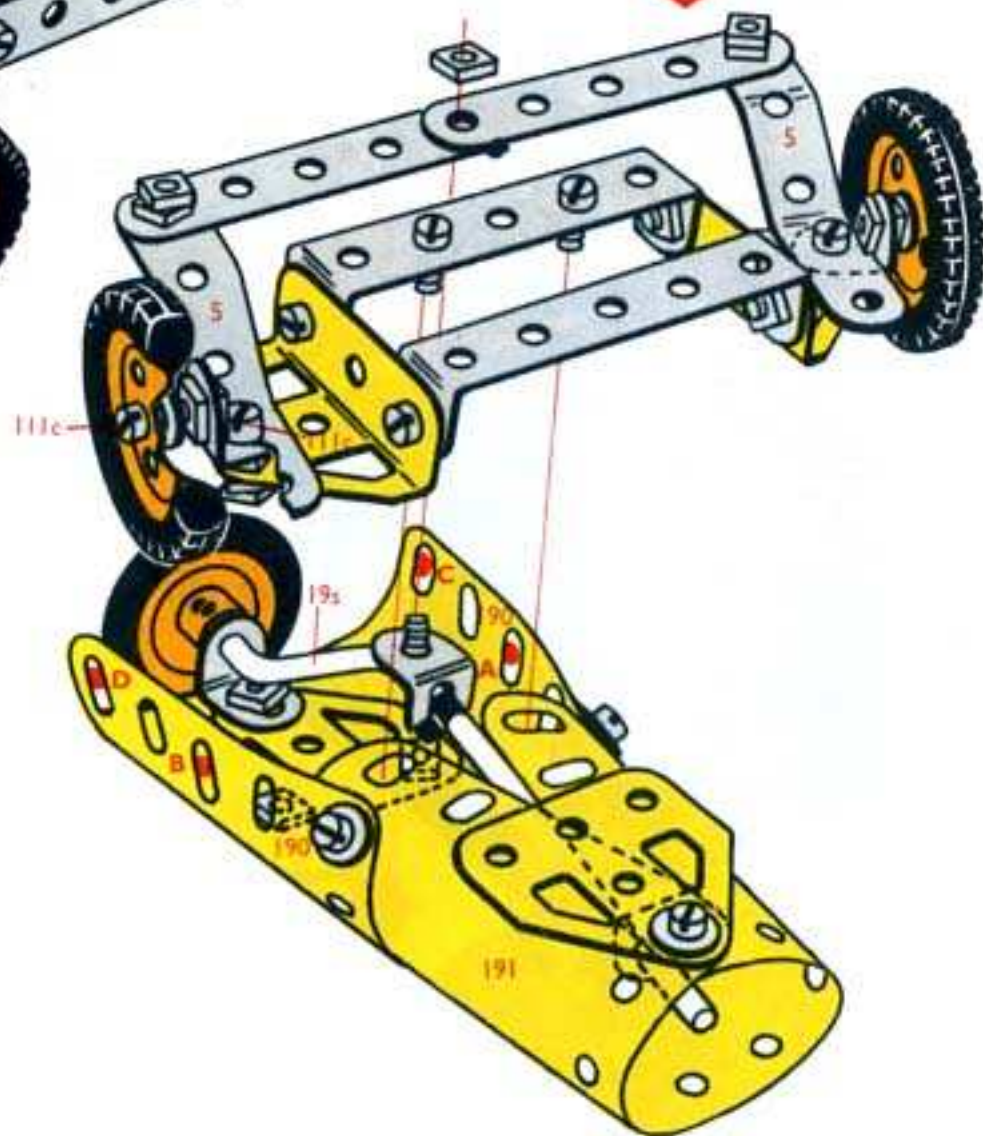

5-	37a
5-	37b
1-	191

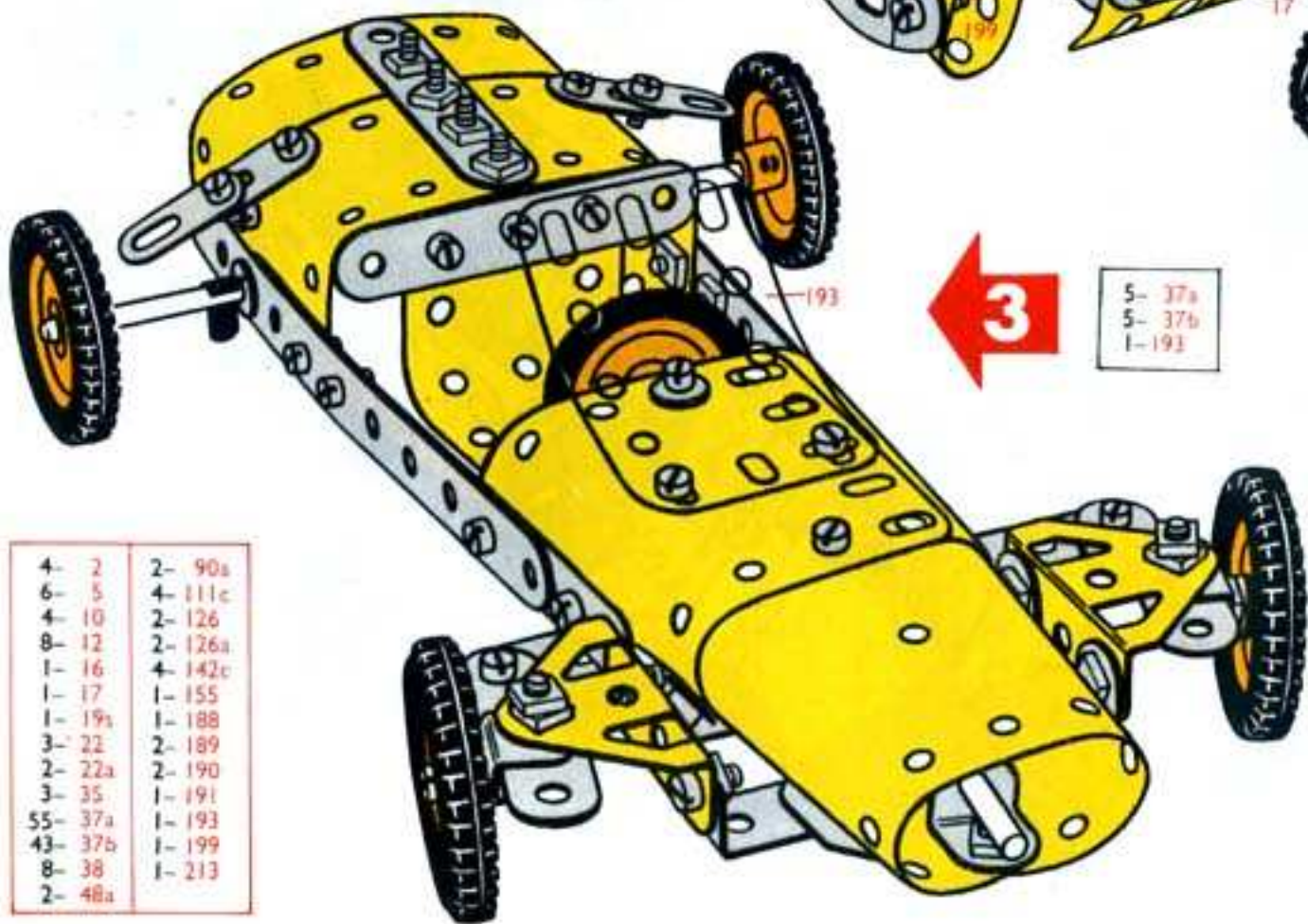

4-	2	2-	90a
6-	5	4-	111c
4-	10	2-	126
8-	12	2-	126a
1-	16	4-	142c
1-	17	1-	155
1-	19s	1-	188
3-	22	2-	189
2-	22a	2-	190
3-	35	1-	191
55-	37a	1-	193
43-	37b	1-	199
8-	38	1-	213
2-	48a		



## 3.8.

Wharf Crane

Havenkraan

Grue de docks

Gru per banchina di carico

Kaikran

Varvskran

Grúa de muelle

Guindaste de cais

Kai-kran

4- 2	1- 24
6- 5	2- 25
3- 10	22- 37a
1- 11	20- 37b
2- 12	3- 38
1- 16	2- 90a
1- 17	1- 111c
1- 18b	2- 126
1- 19a	2- 126a
1- 20a	1- 155
3- 22	1- 176
1- 22a	1- 189

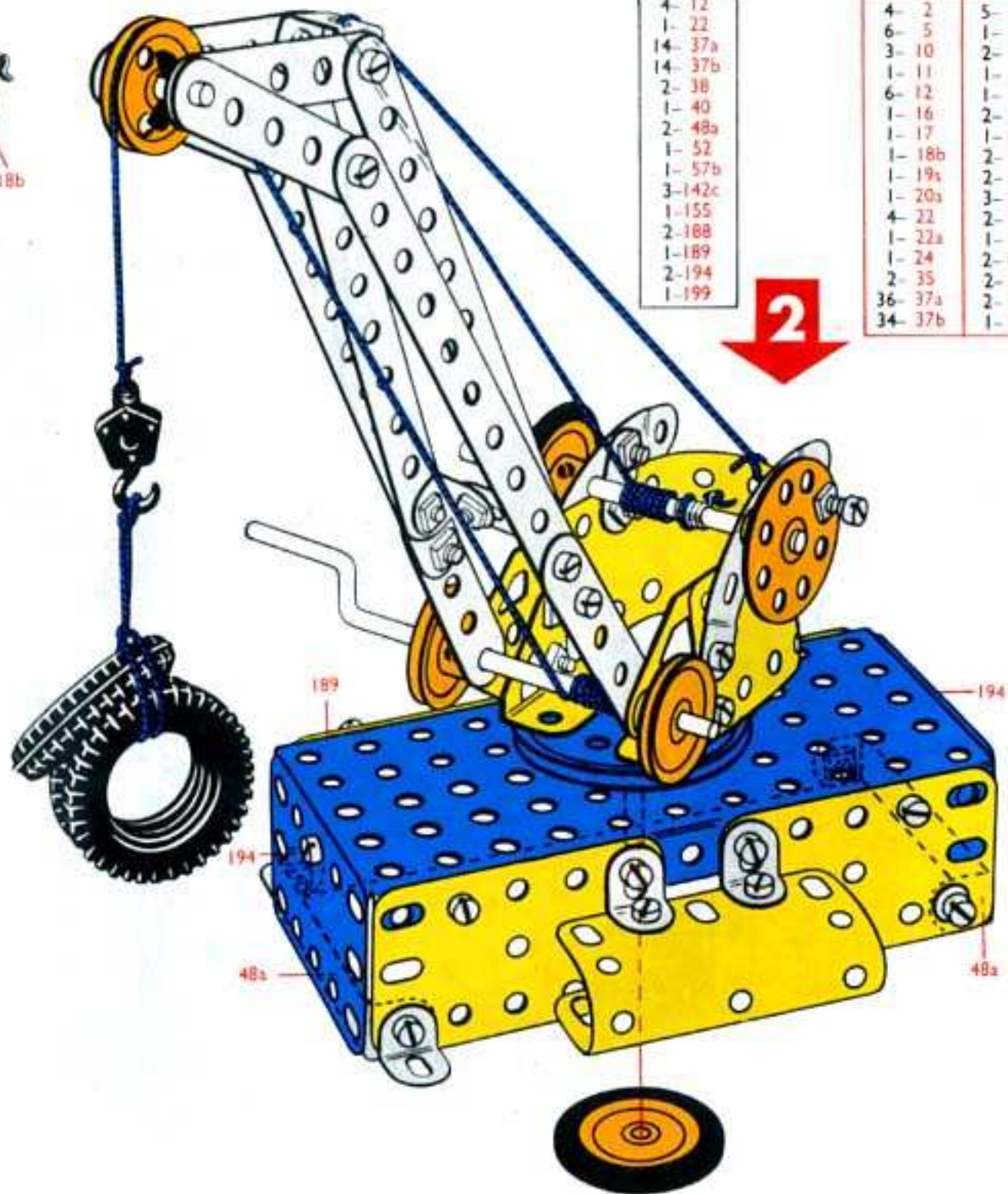
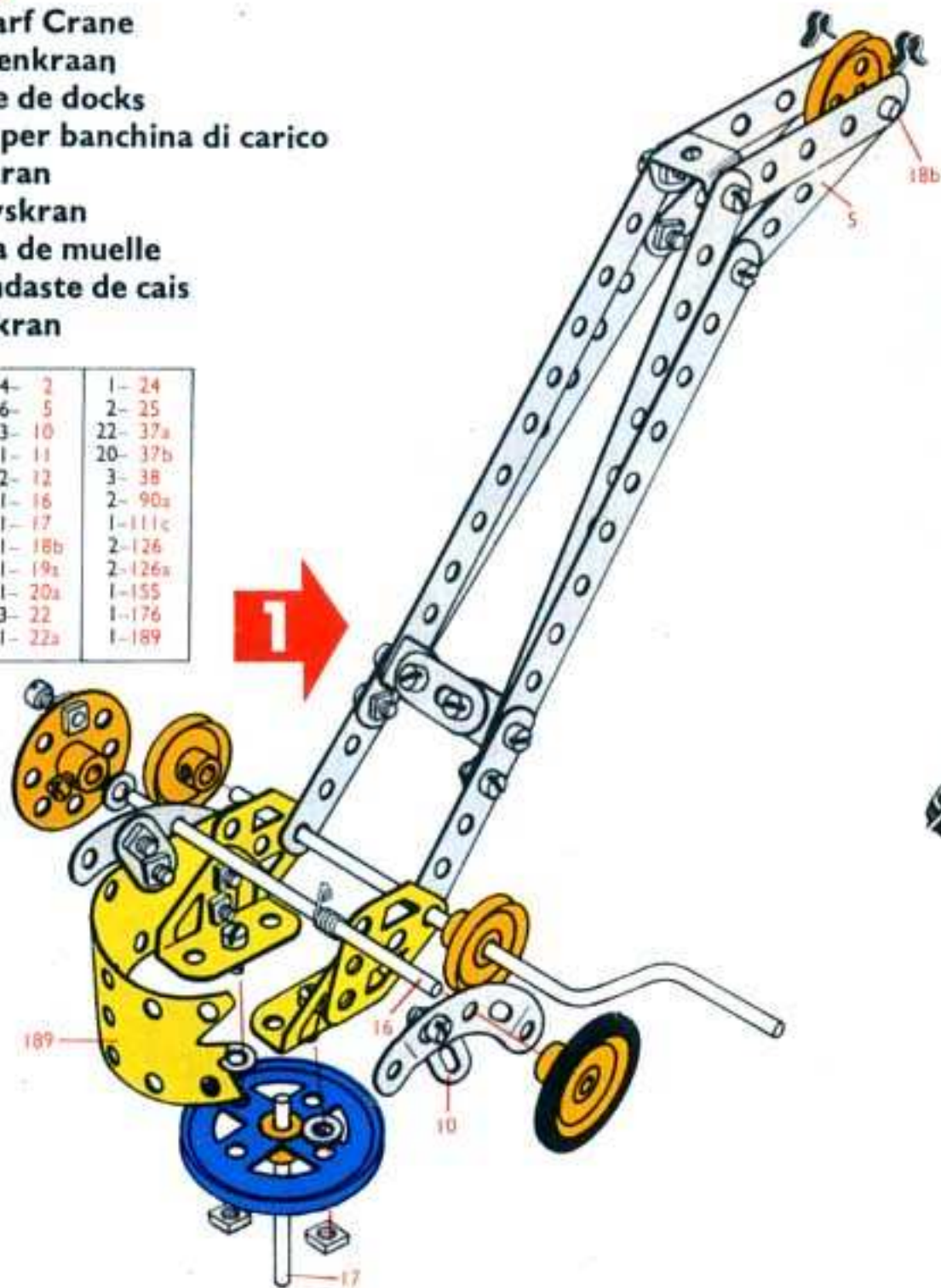

4- 12
1- 22
14- 37a
14- 37b
2- 38
1- 40
2- 48a
1- 52
1- 57b
3- 142c
1- 155
2- 188
1- 189
2- 194
1- 199

4- 2	5- 38
6- 5	1- 40
3- 10	2- 48a
1- 11	1- 52
6- 12	1- 57b
1- 16	2- 90a
1- 17	1- 111c
1- 18b	2- 126
1- 19a	2- 126a
1- 20a	3- 142c
4- 22	2- 155
1- 22a	1- 176
1- 24	2- 188
2- 35	2- 189
36- 37a	2- 194
34- 37b	1- 199

## 3.9.

Diesel Shunter

Dieselrangeerwagen

Machine Diesel de manoeuvres

Locomotore diesel per smistamento

Diesel-Rangierlok

Dieseldrivet växellok

Locomotora diesel para maniobras

Locomotiva Diesel de triagem

Diesel skiftelokomotiv

2-	2
4-	10
6-	12
30-	37a
30-	37b
5-	38
2-	126a
2-	189
2-	190
1-	191
1-	194

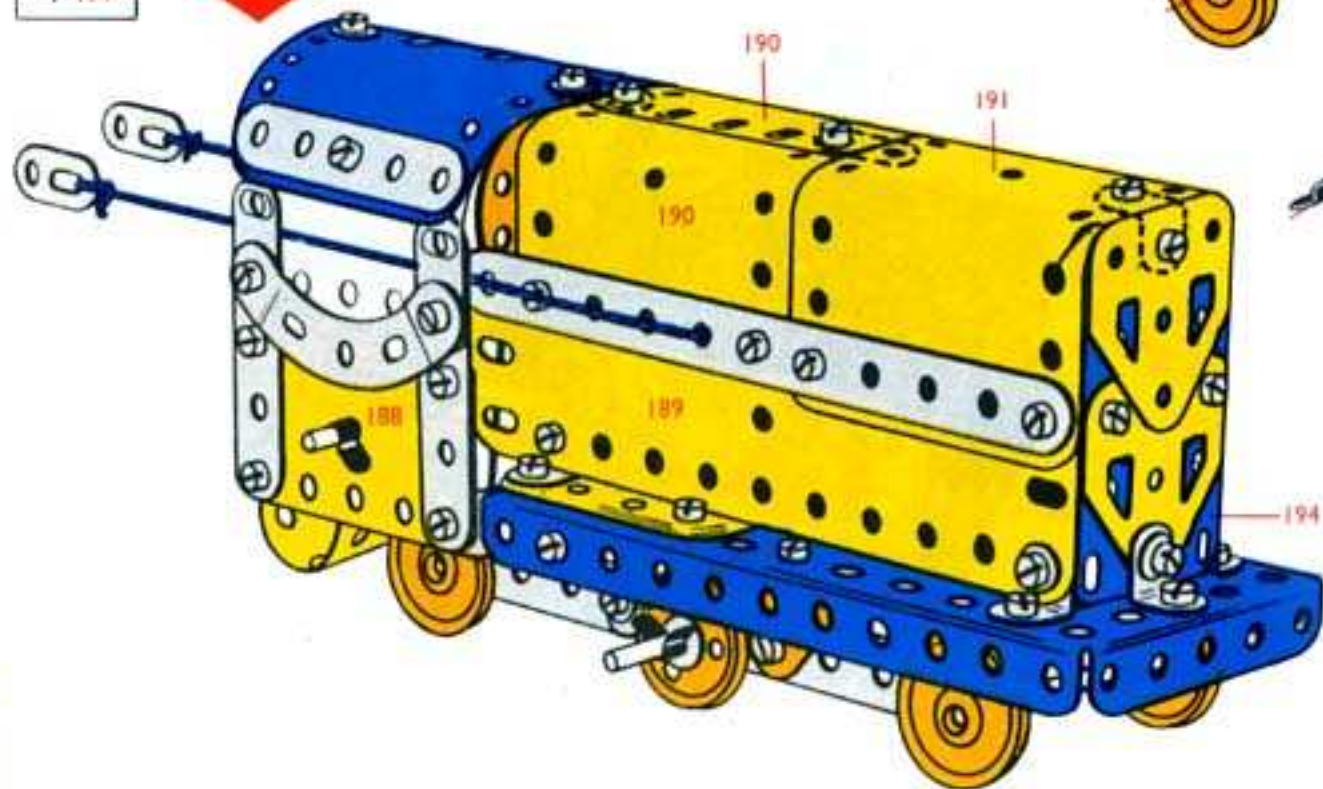

2-	2
2-	12
1-	16
2-	17
4-	22
2-	22a
* 1-	23a
1-	24
4-	35
14-	37a
14-	37b
4-	38
1-	40
2-	48a
1-	52
1-	125
2-	126
* 1-	186a
1-	199

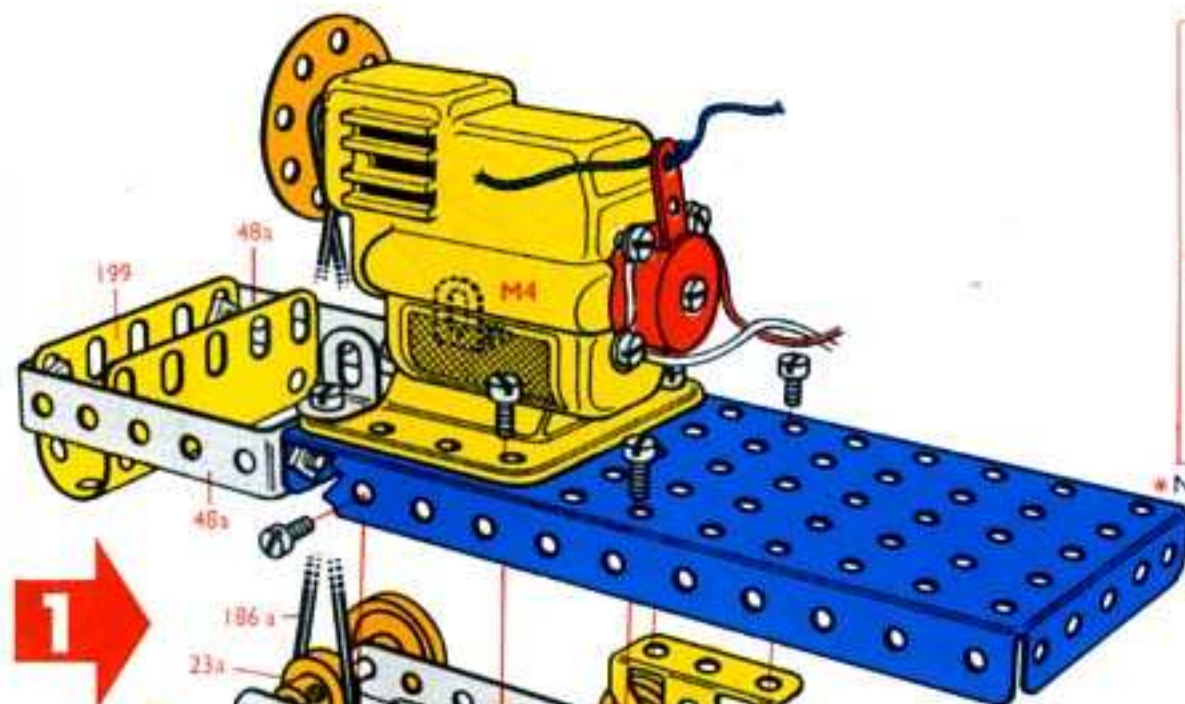

4-	2	2-	90a
6-	5	3-	111c
4-	10	1-	125
8-	12	2-	126
2-	16	2-	126a
2-	17	* 1-	186a
4-	22	2-	188
2-	22a	2-	189
* 1-	23a	2-	190
6-	35	1-	191
55-	37a	2-	193
50-	37b	1-	194
10-	38	2-	194a
1-	40	1-	199
2-	48a	* 1-	M4
1-	52		

\* Not included in set No.3

6-	5
1-	16
2-	35
11-	37a
9-	37b
1-	38
2-	90a
3-	111c
2-	188
2-	193
2-	194a

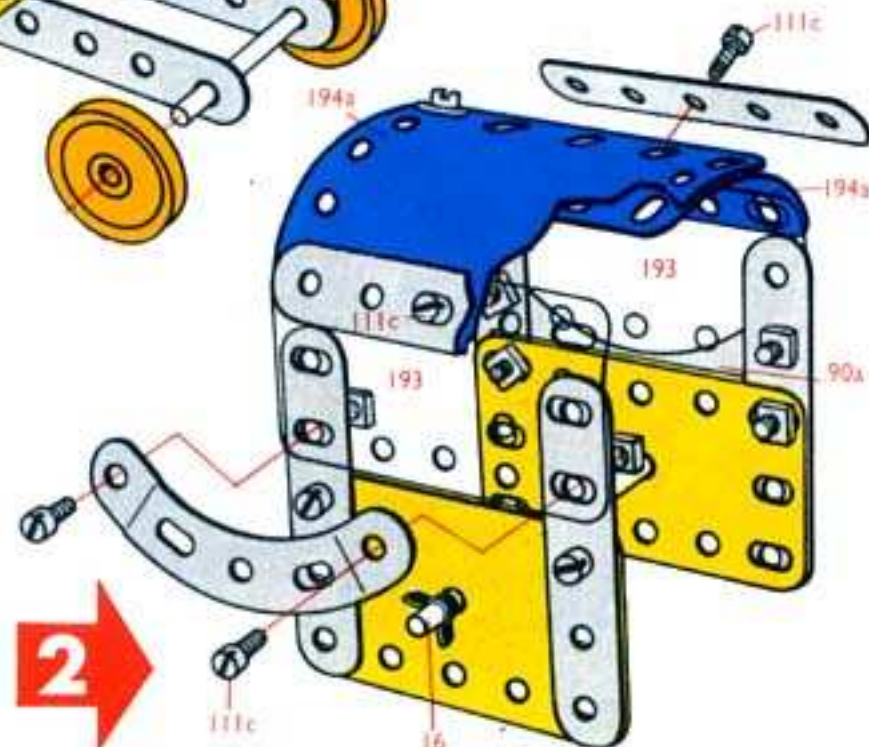

**3.10.**  
**Stamping Mill**  
**Walserij**  
**Moulin à bocards**  
**Frantumatore**  
**Stanzanlage**  
**Stampverk**  
**Prensa estampadora**  
**Estampadora**  
**Pukkverk**

- 4- 2
- 5- 5
- 6- 12
- 34- 37a
- 34- 37b
- 2- 38
- 2- 48a
- 1- 52
- 2- 90a
- 2- 126
- 2- 126a
- 2- 189
- 2- 190

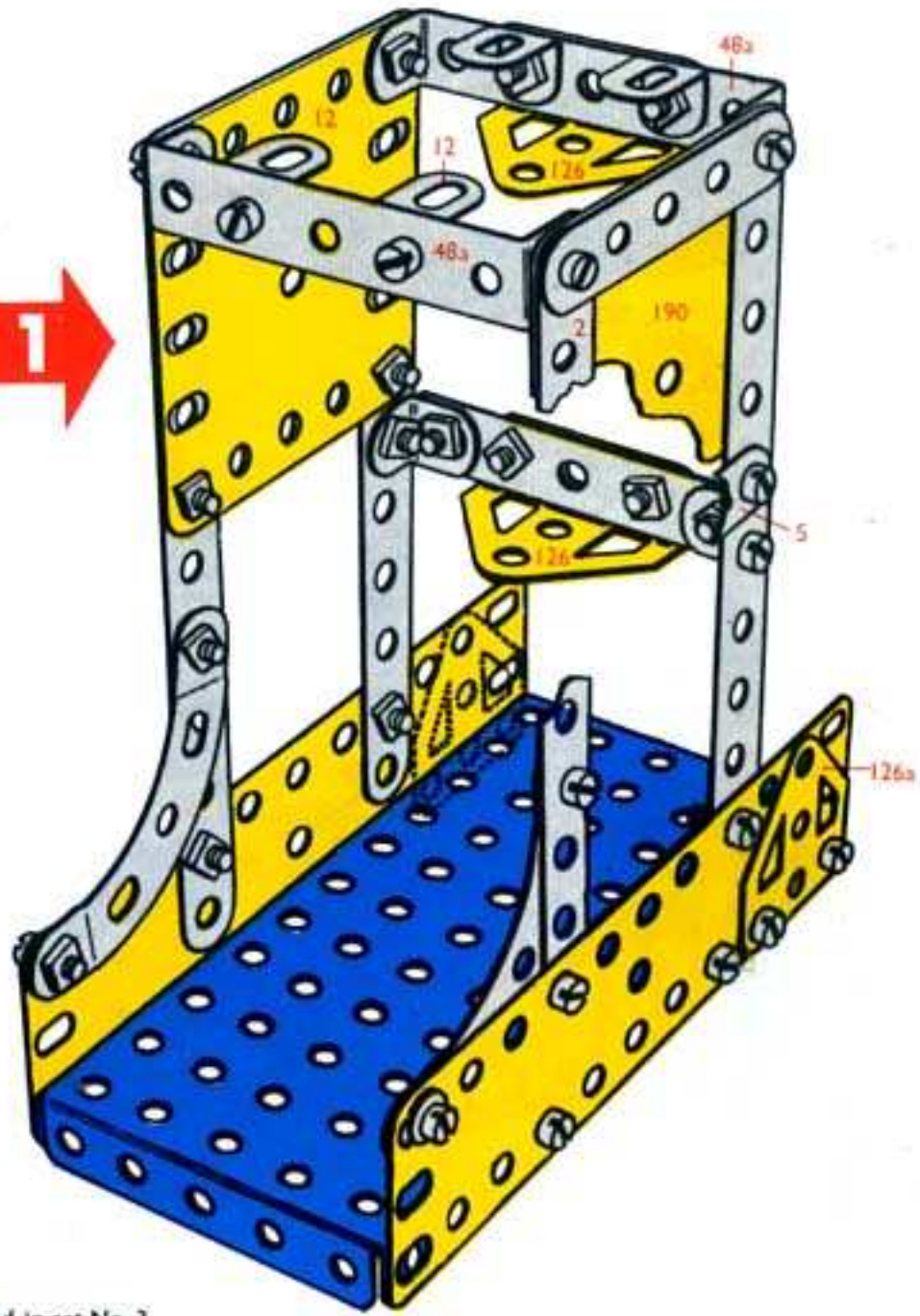

- 4- 2
- 5- 5
- 2- 10
- 8- 12
- 2- 16
- 1- 19a
- 1- 20a
- 4- 22
- \* 1- 23a
- 1- 24
- 3- 35
- 44- 37a
- 45- 37b
- 6- 38
- 2- 48a
- 1- 52
- 2- 90a
- 2- 126
- 2- 126a
- \* 1- 186b
- 2- 188
- 2- 189
- 2- 190
- \* 1- M4

\* Not included in set No. 3

- 2- 10
- 2- 12
- 2- 16
- 1- 19a
- 1- 20a
- 4- 22
- \* 1- 23a
- 1- 24
- 3- 35
- 10- 37a
- 11- 37b
- 3- 38
- \* 1- 186b
- 2- 188

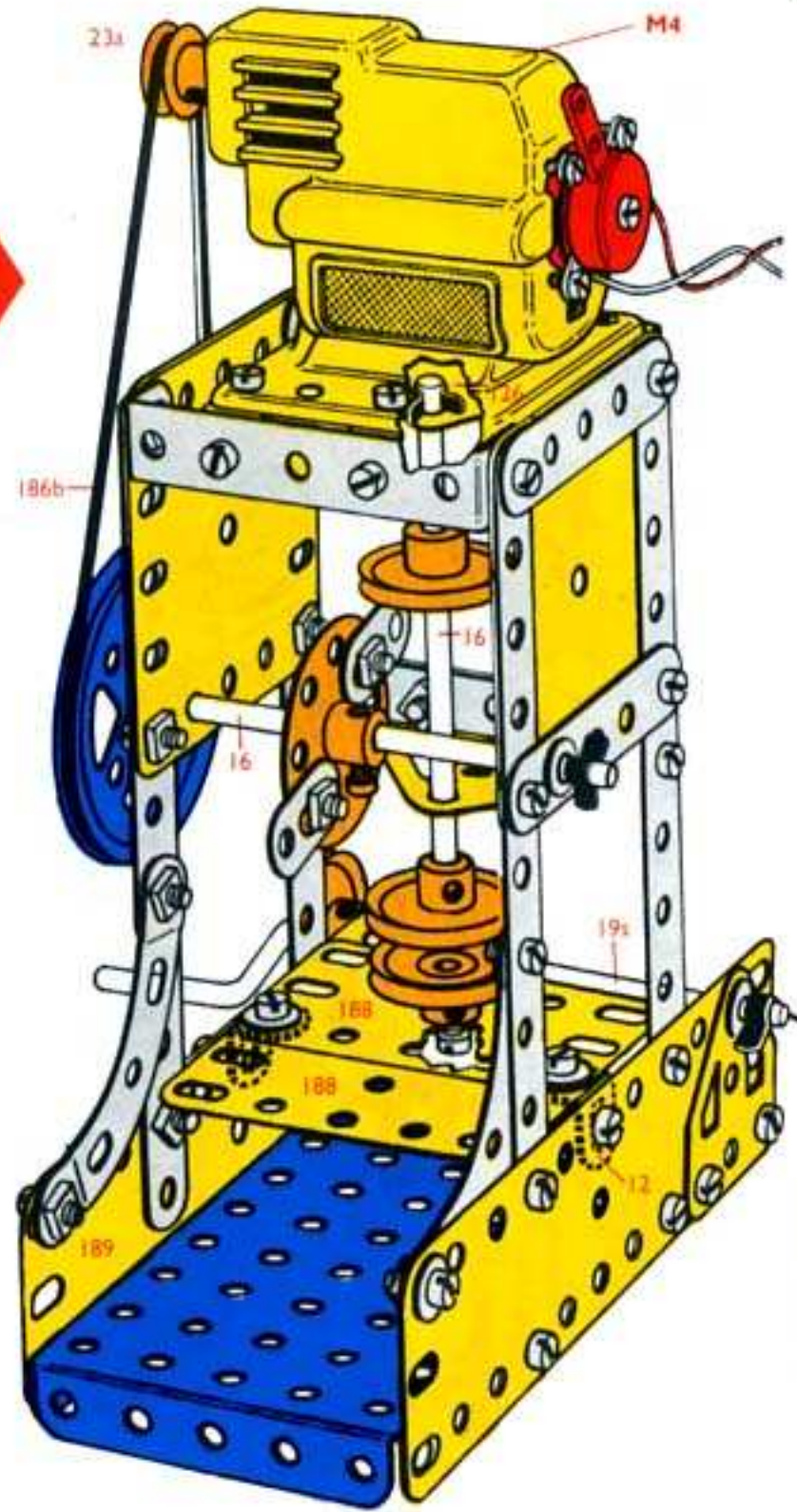

### 3.11.

**Fire Escape**  
**Branduitgang**  
**Echelle à incendie**  
**Uscita di sicurezza in caso d'incendio**  
**Feuerleiter**  
**Brandräddningsutrustning**  
**Escalera para caso de incendio**  
**Escada de incêndio**  
**Brannstige**

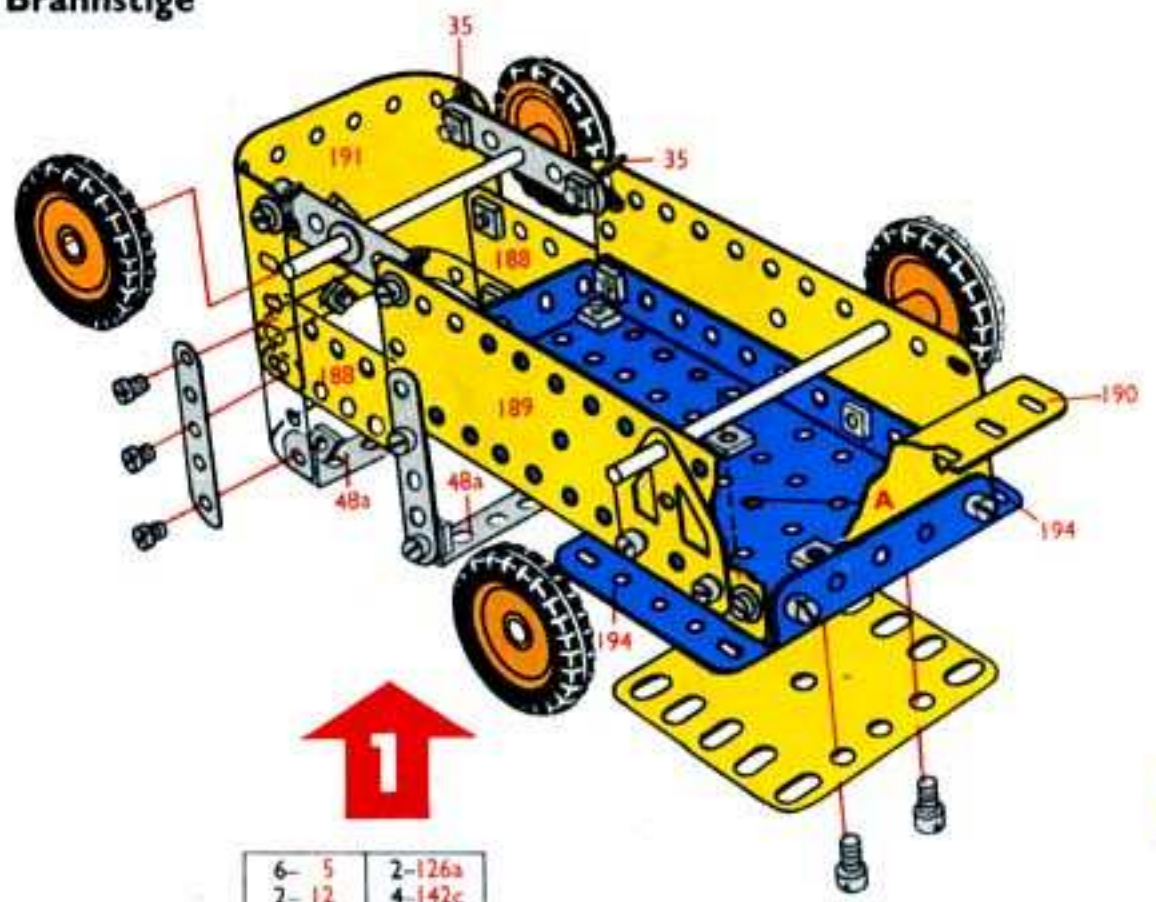

6- 5	2-126a
2- 12	4-142c
2- 16	2-188
4- 22	2-189
4- 35	1-190
34- 37a	1-191
30- 37b	2-193
8- 38	2-194
2- 48a	1-199
1- 52	
4-111c	

2- 12
1- 22a
10- 37a
10- 37b
2- 90a
1-190
1-194a

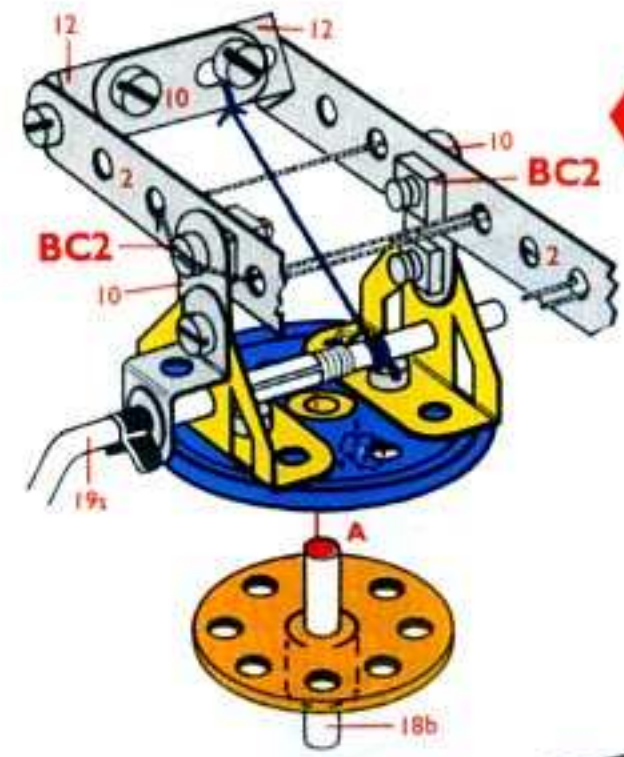

4- 2
4- 10
4- 12
1- 18b
1- 19s
1- 20a
1- 24
1- 35
12- 37a
10- 37b
2- 38
1- 40
1-125
2-126
1-176
1-212
1-213

4- 2	2- 90a
6- 5	4-111c
4- 10	1-125
8- 12	2-126
2- 16	2-126a
1- 18b	4-142c
1- 19s	1-176
1- 19s	2-188
1- 20a	2-189
4- 22	2-190
1- 22a	2-191
1- 24	1-191
5- 35	2-193
56- 37a	2-194
50- 37b	1-194a
10- 38	1-199
1- 40	1-212
2- 48a	1-213
1- 52	

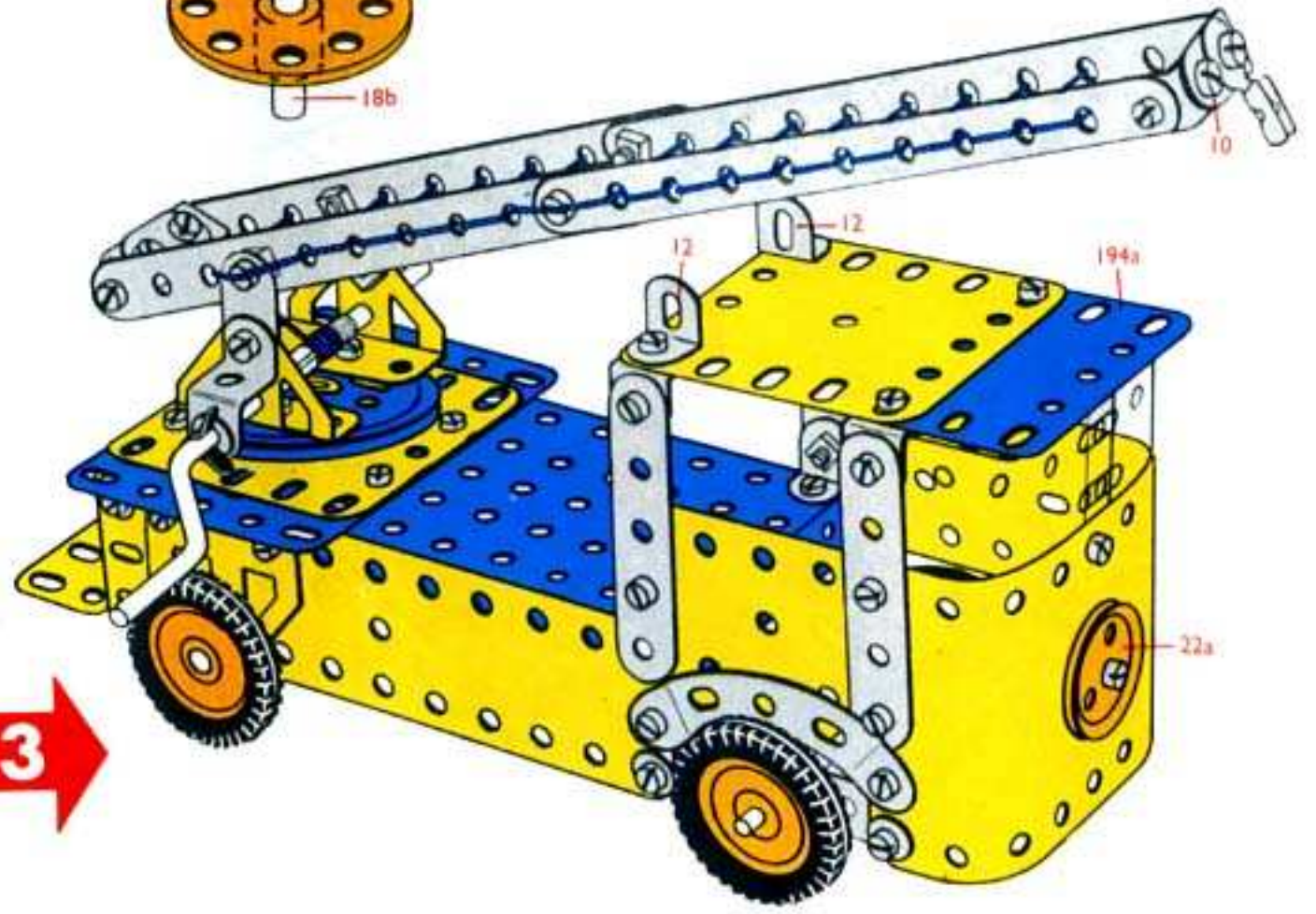

## 3.12.

Jet Plane  
 Straalvliegtuig  
 Avion à réaction  
 Aviogetto  
 Düsenflugzeug  
 Jetflygplan  
 Avión reactor  
 Avião de jacto  
 Jetfly

3	2
2	5
2	12
2	22
12	37a
12	37b
2	38
2	111c
1	188
2	189
2	190
1	191

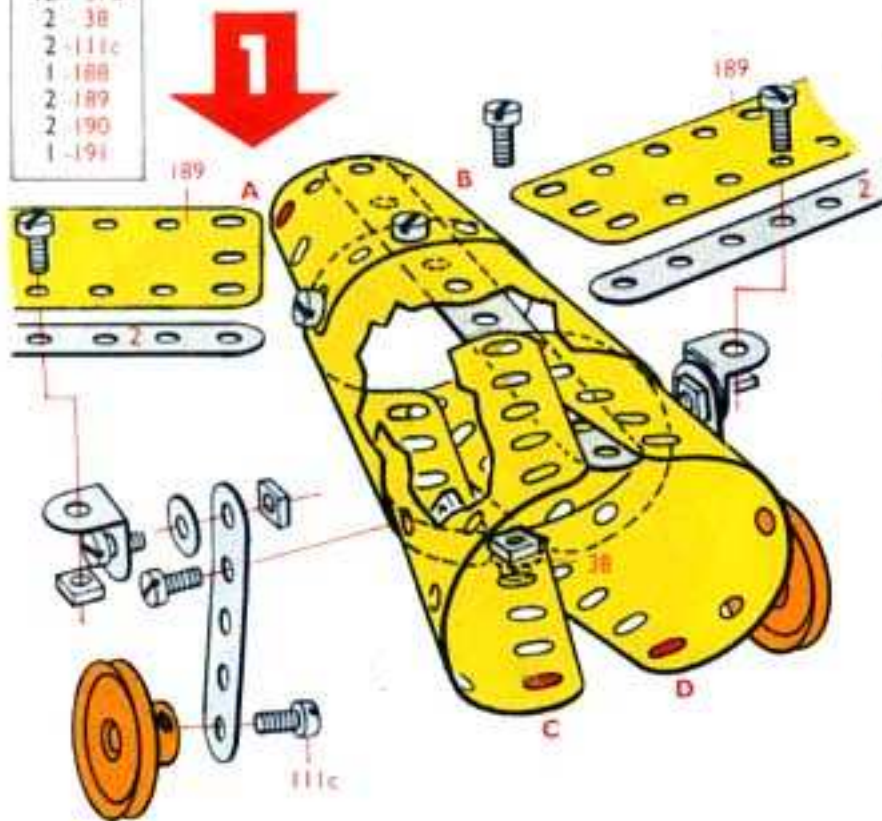

1	5
4	12
11	37a
11	37b
2	38
1	90a
2	126
2	194

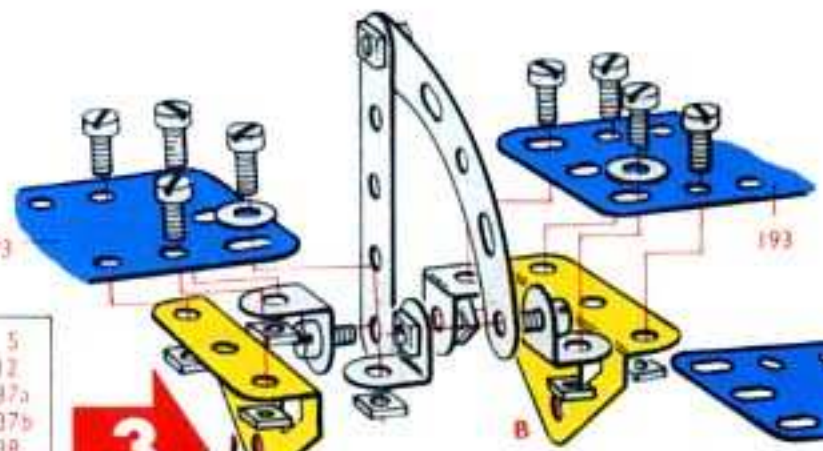

5	37a
5	37b
1	38

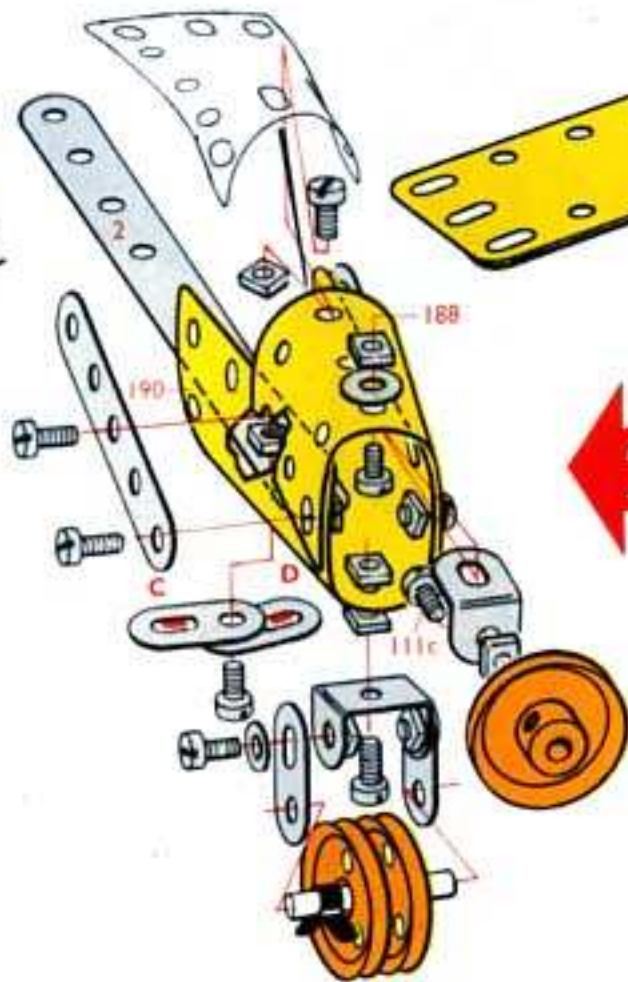

1	2
2	5
4	10
1	11
1	12
1	18b
1	22
2	22a
1	35
13	37a
10	37b
3	38
1	111c
1	188
1	193
1	199

4	2	8	38
5	5	1	90a
4	10	3	111c
1	11	2	126
7	12	2	188
1	18b	2	189
3	22	2	190
2	22a	1	191
1	35	1	193
42	37a	2	194
39	37b	1	199

BC2

## 3.13.

Cement Mixer  
 Betonmolen  
 Mélangeur de ciment  
 Betoniera  
 Zementmischer  
 Betongblandare  
 Hormigonera  
 Betoneira  
 Sementblander

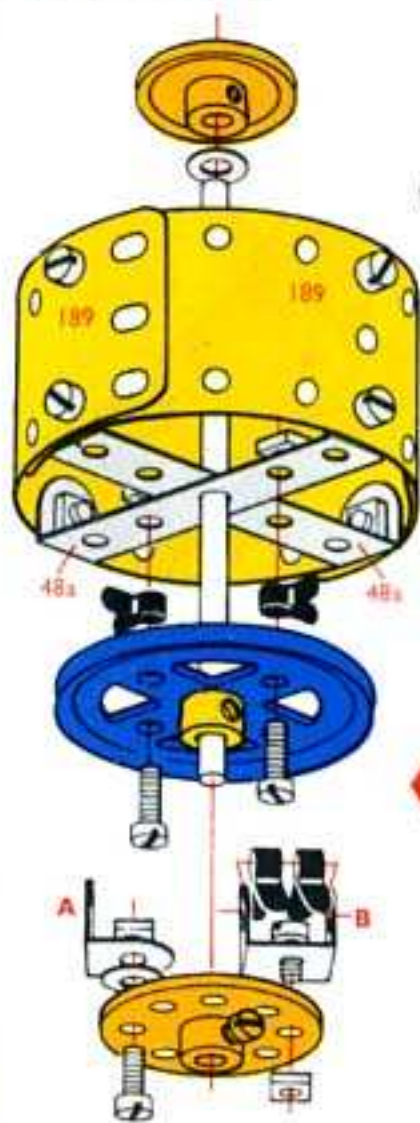

1- 11
1- 12
1- 16
1- 20a
1- 22
1- 24
4- 35
10- 37a
8- 37b
2- 38
2- 48a
2- 111c
2- 189

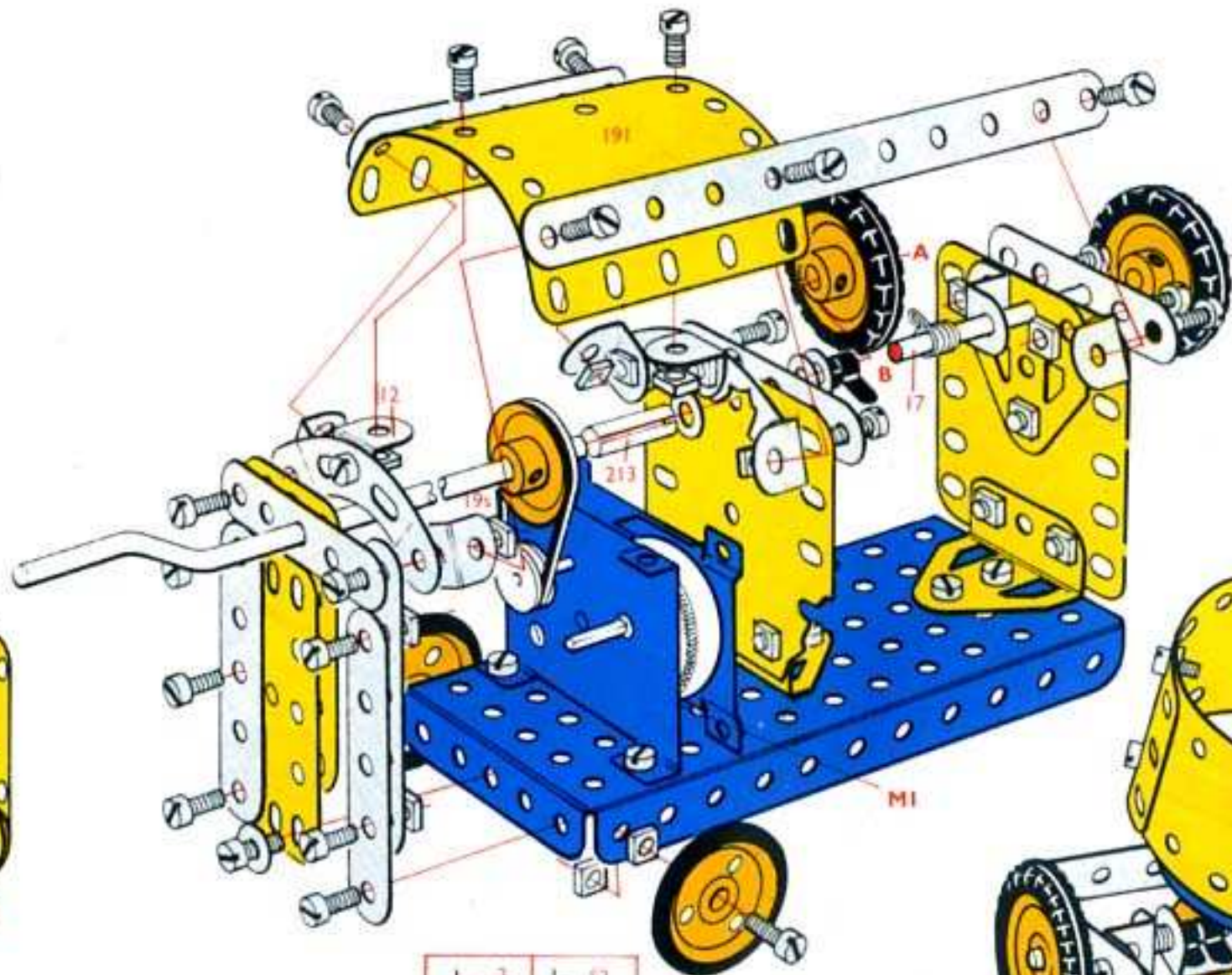

1- 2	1- 52
6- 5	2- 90a
1- 11	4- 111c
8- 12	1- 125
1- 16	2- 126
1- 17	1- 126a
1- 19a	2- 142c
1- 20a	2- 155
4- 22	1- 176
2- 22a	1- 186
1- 24	2- 188
5- 35	2- 189
49- 37a	2- 190
43- 37b	1- 191
5- 38	1- 212
2- 48a	1- 213
* 1- M1	

\* Not included in set

1- 2	2- 111c
6- 5	1- 125
7- 12	2- 126
1- 17	1- 126a
1- 19a	2- 142c
3- 22	2- 155
2- 22a	1- 176
1- 35	1- 186
39- 37a	2- 188
35- 37b	2- 190
3- 38	1- 191
1- 52	1- 212
2- 90a	1- 213

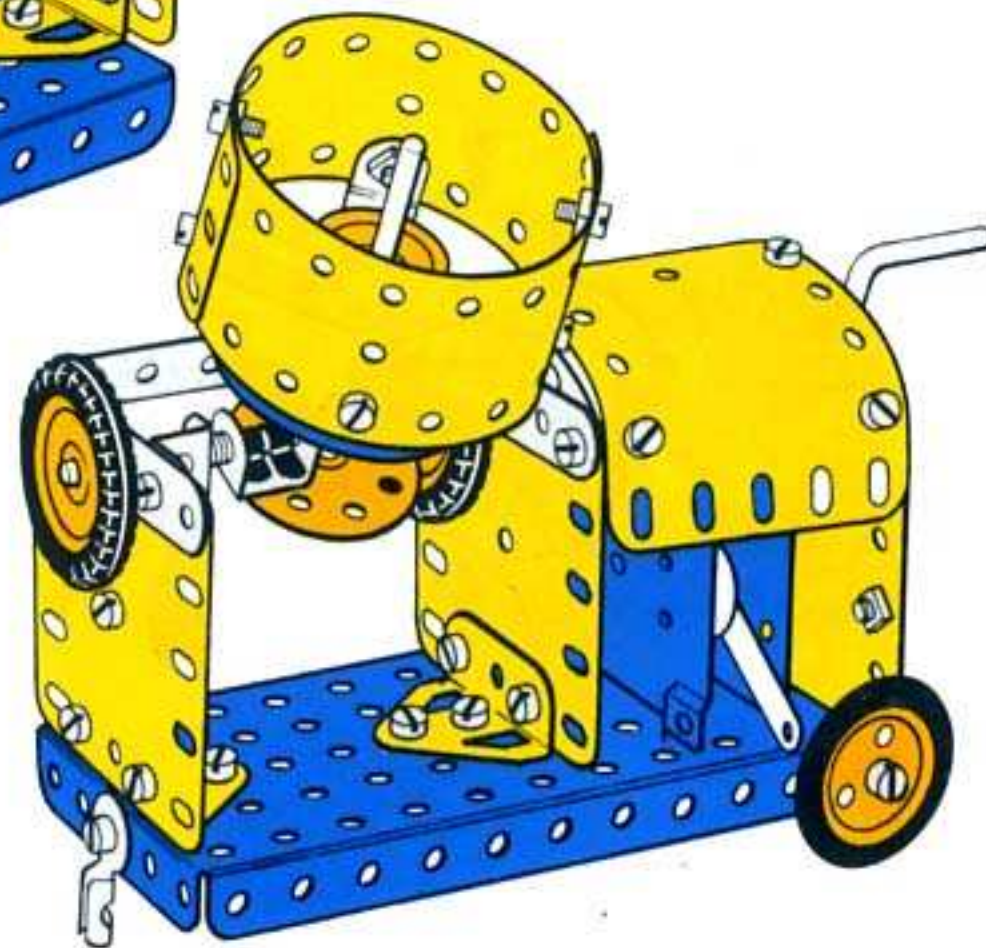

### 3.14.

Articulated Lorry  
 Opleggervoertuig  
 Camion à semi-remorque  
 Autocarro articolato  
 Gelenk-Lkw  
 Ledad lastbil  
 Camión articulado  
 Camião articulado  
 Semitrailer

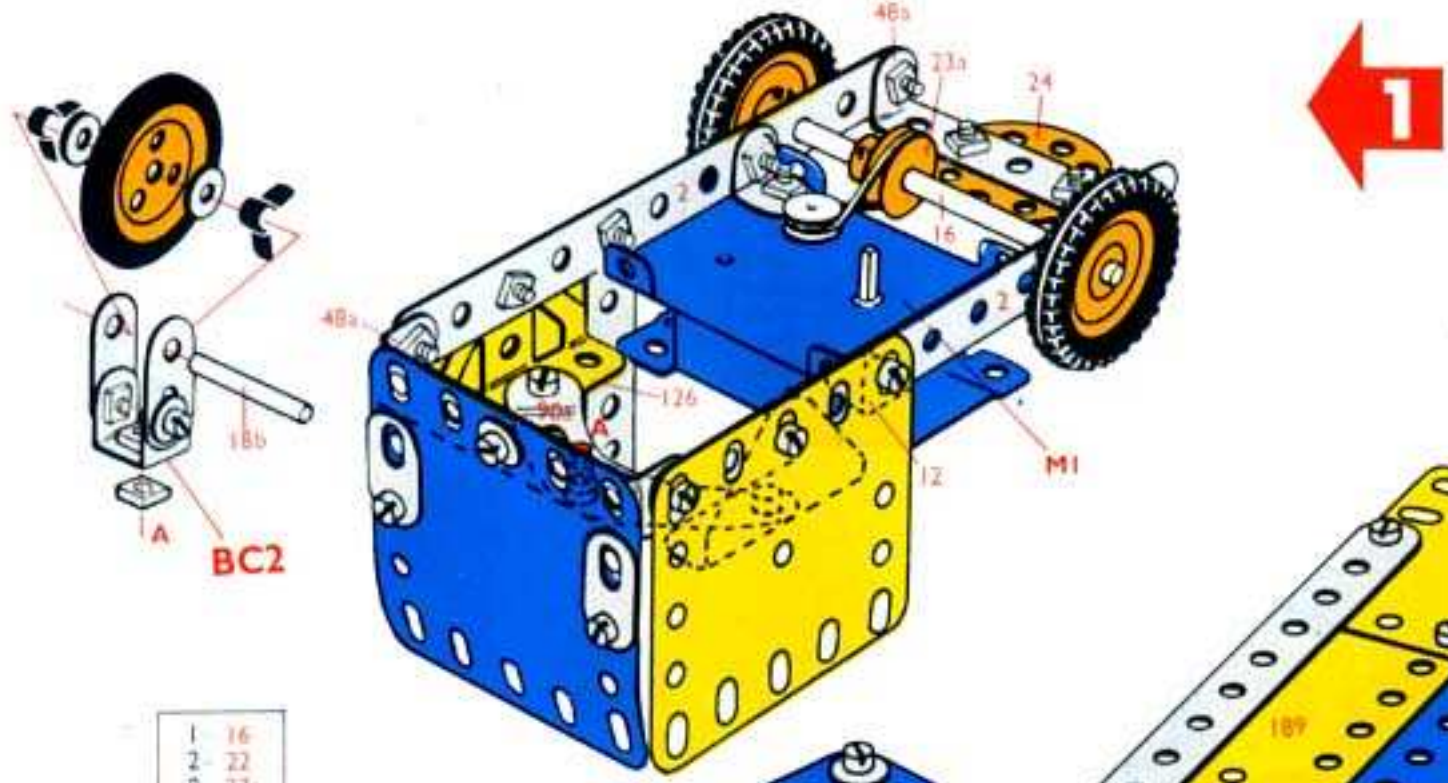

2	2	22	37a
2	5	21	37b
4	10	5	38
1	11	2	49a
2	12	1	90a
1	16	2	126
1	18b	2	142c
2	22	1	155
1	23a	1	186
*1	23a	2	190
1	24	1	194a
2	35		

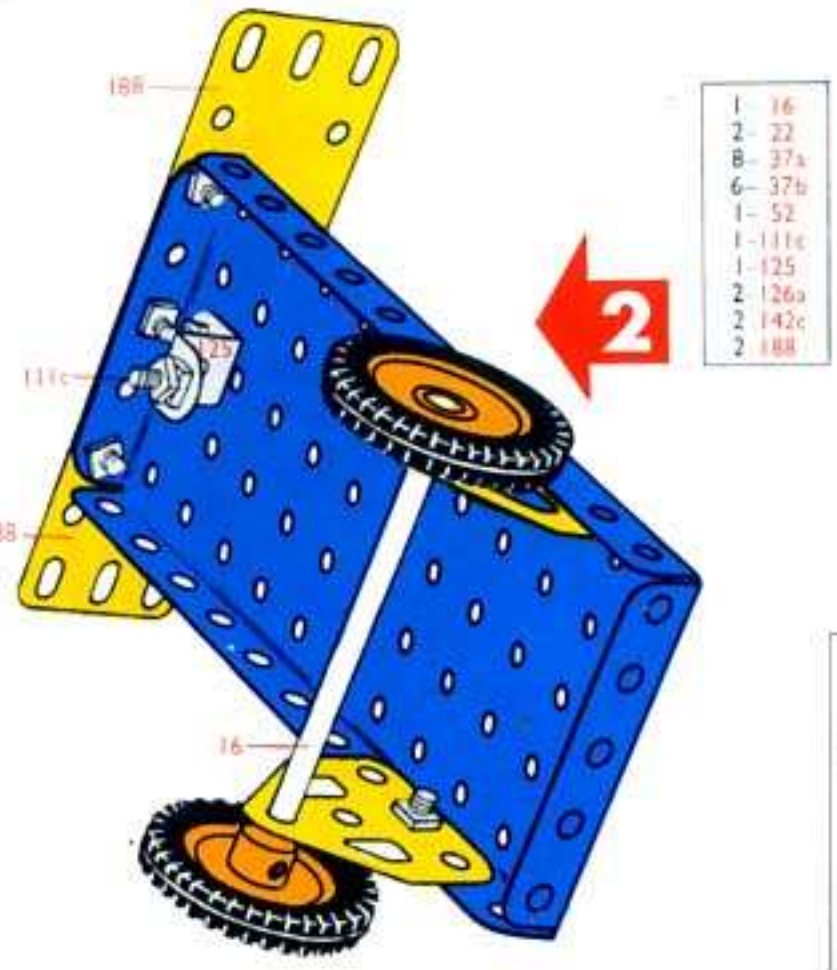

1	16
2	22
8	37a
6	37b
1	52
1	111c
1	125
2	126a
2	142c
2	188

2	2
4	5
6	12
23	37a
23	37b
4	38
1	90a
2	189
1	191
1	193
1	194a
1	212

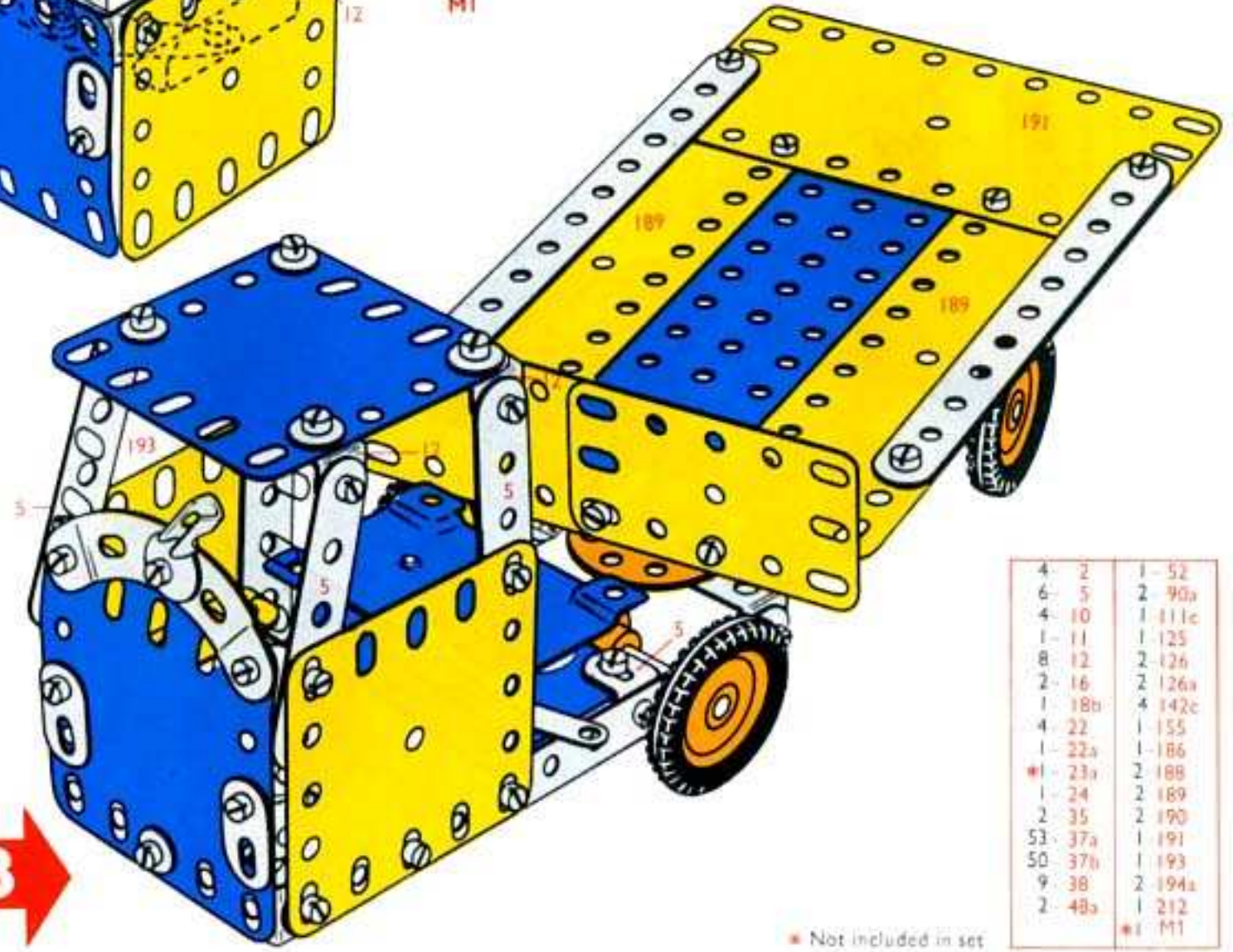

4	2	1	52
6	5	2	90a
4	10	1	111c
1	11	1	125
8	12	2	126
2	16	2	126a
1	18b	4	142c
4	22	1	155
1	22a	1	186
*1	23a	2	188
1	24	2	189
2	35	2	190
53	37a	1	191
50	37b	1	193
9	38	2	194a
2	48a	1	212
*1	M1		

\* Not included in set

### 3.15.

Tractor Dozer  
 Rupsbandtractor  
 Tracteur à chenilles avec bulldozer  
 Trattore-Dozer  
 Fronträumer  
 Schaktningstraktor  
 Topadora oruga  
 Tractor  
 Traktor-dozer

4-	2	15-	37b
2-	5	10-	38
1-	11	2-	48a
2-	12	1-	52
2-	16	2-	90a
1-	17	3-	111c
1-	20a	2-	126
4-	22	2-	126a
1-	35	4-	142c
23-	37a	1-	191

4-	2	2-	48a
6-	5	1-	52
4-	10	2-	90a
1-	11	3-	111c
8-	12	2-	126
2-	16	2-	126a
1-	17	4-	142c
1-	18b	2-	188
1-	20a	2-	189
4-	22	2-	190
1-	24	1-	191
2-	35	1-	194
56-	37a	2-	194a
50-	37b	1-	199
10-	38	1-	213

4	5
2	10
6	12
1	18b
1	24
1	35
27	37a
27	37b
2	188
2	189
2	190
1	194
2	194a
1	199
1	213

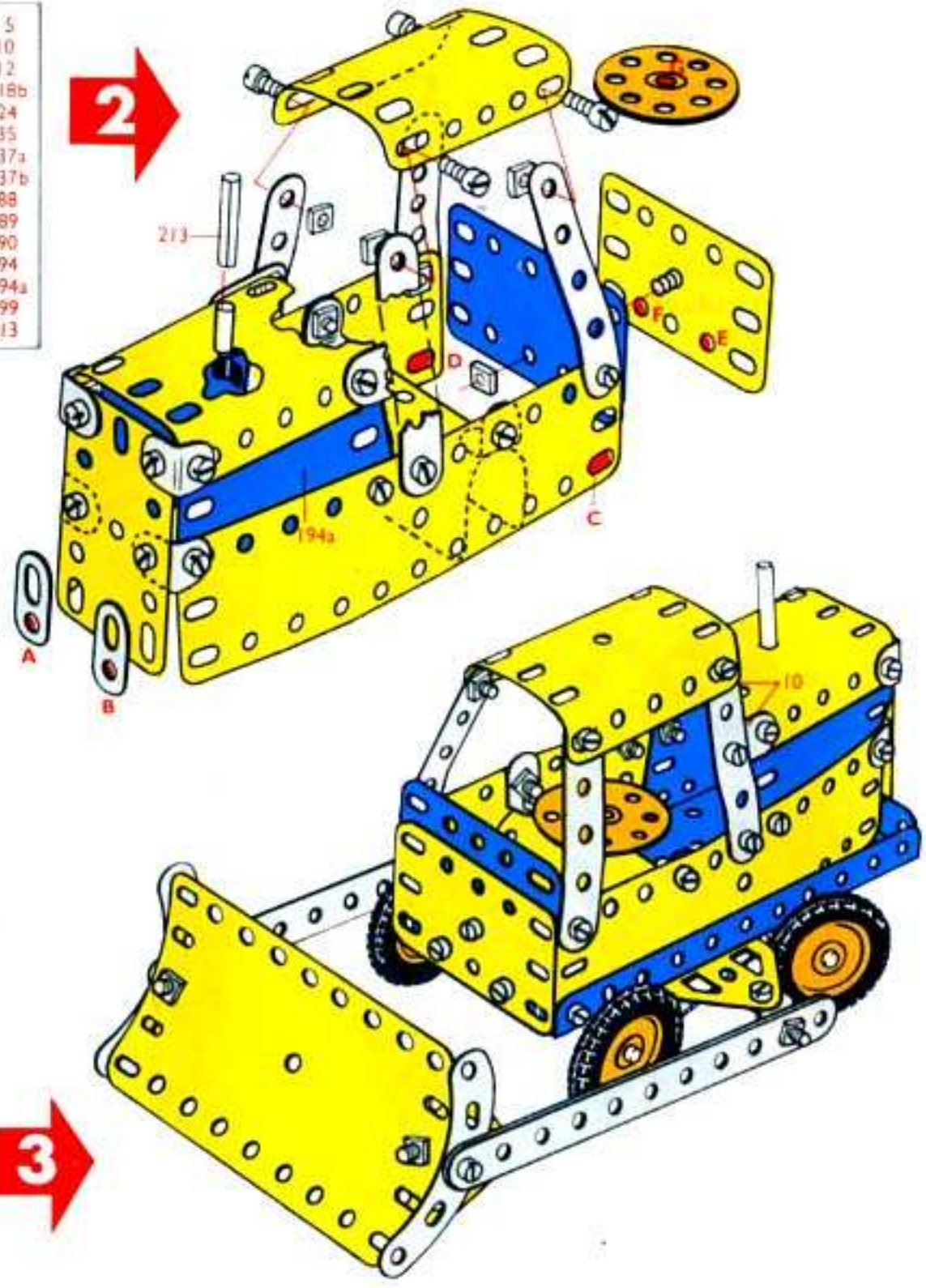
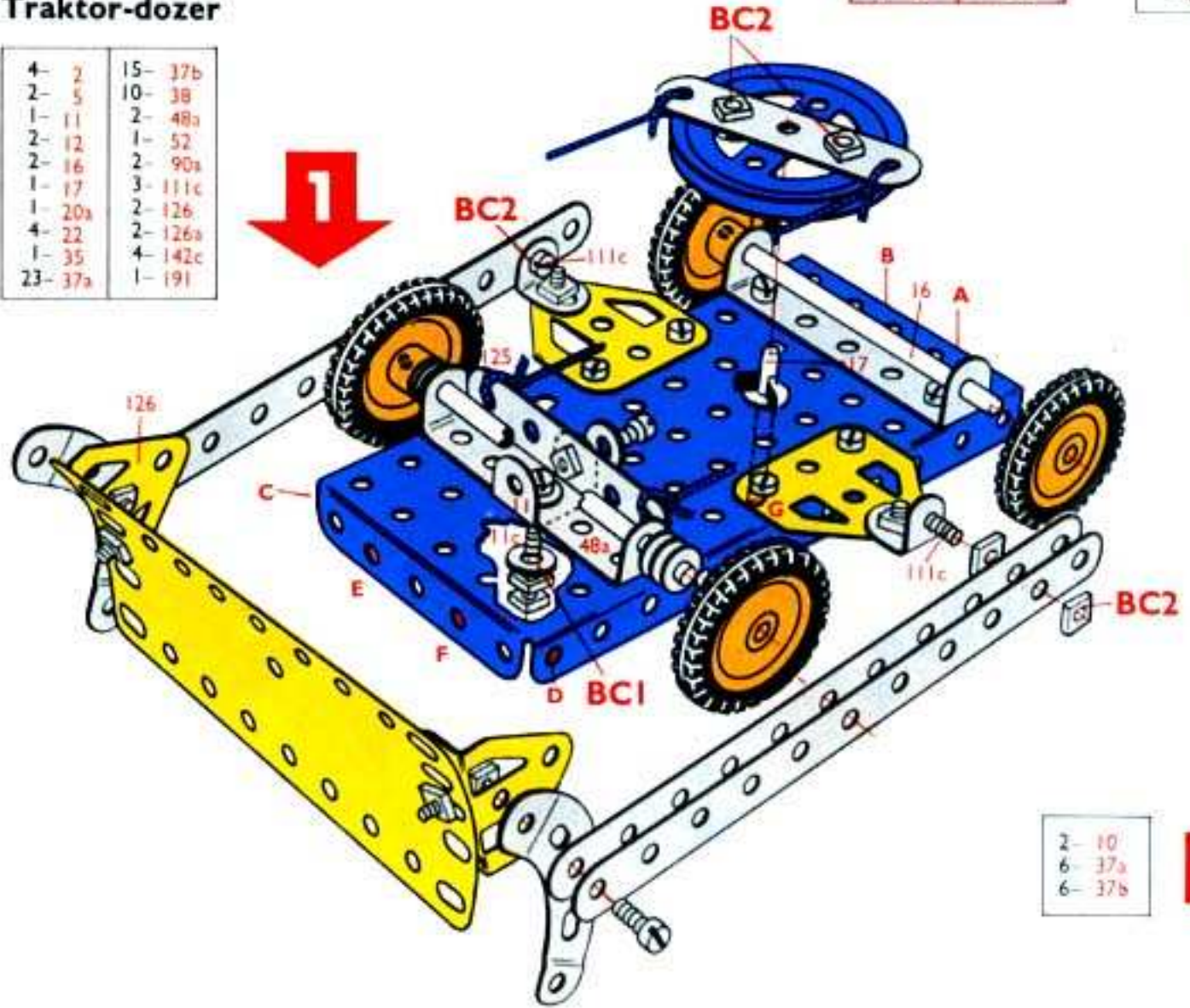

2-	10
6-	37a
6-	37b



## 3.16.

Side Fork Lift Truck

Zijvorkheftruck

Chariot élévateur à fourche latérale

Carrello per inforcamento laterale

Seitenhubstapler

Sidolastande gaffeltruck

Carretilla elevadora de horquilla lateral

Carrinho com forquilha de elevação lateral

Gaffel truck med sidegaffel

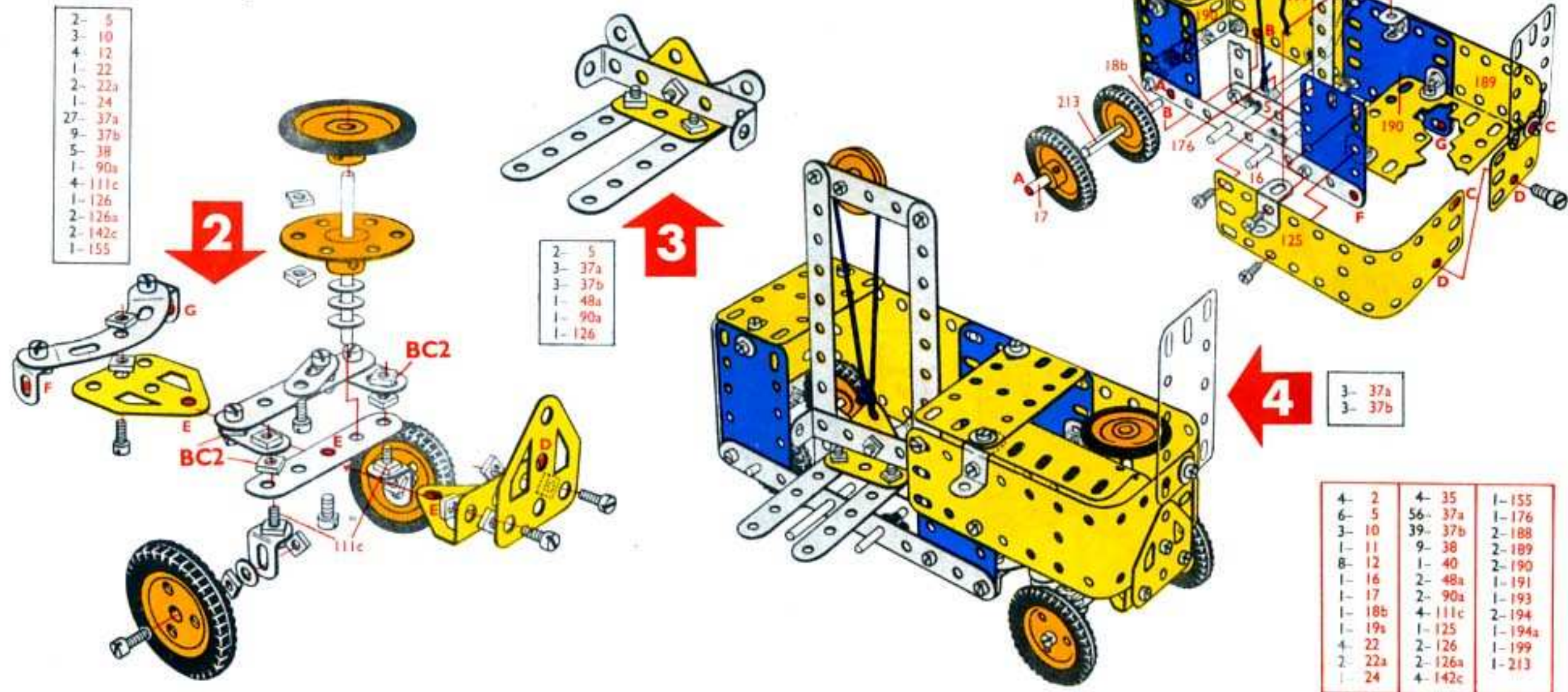

## 4.1.

## Flying Jets

Vliegende straalvliegtuigen

Avions à réaction en vol

Aviogetti in volo

Düsenflieger

Flygande jetplan

Aviones reactores

Aviões de jacto

Jetfly

2- 2	2- 38d
2- 12	1- 52
1- 19a	4- 90a
1- 20a	6- 111c
1- 24	2- 126a
1- 27f	*1- 186a
1- 35	2- 190
24- 37a	2- 191
18- 37b	2- 192
1- 38	

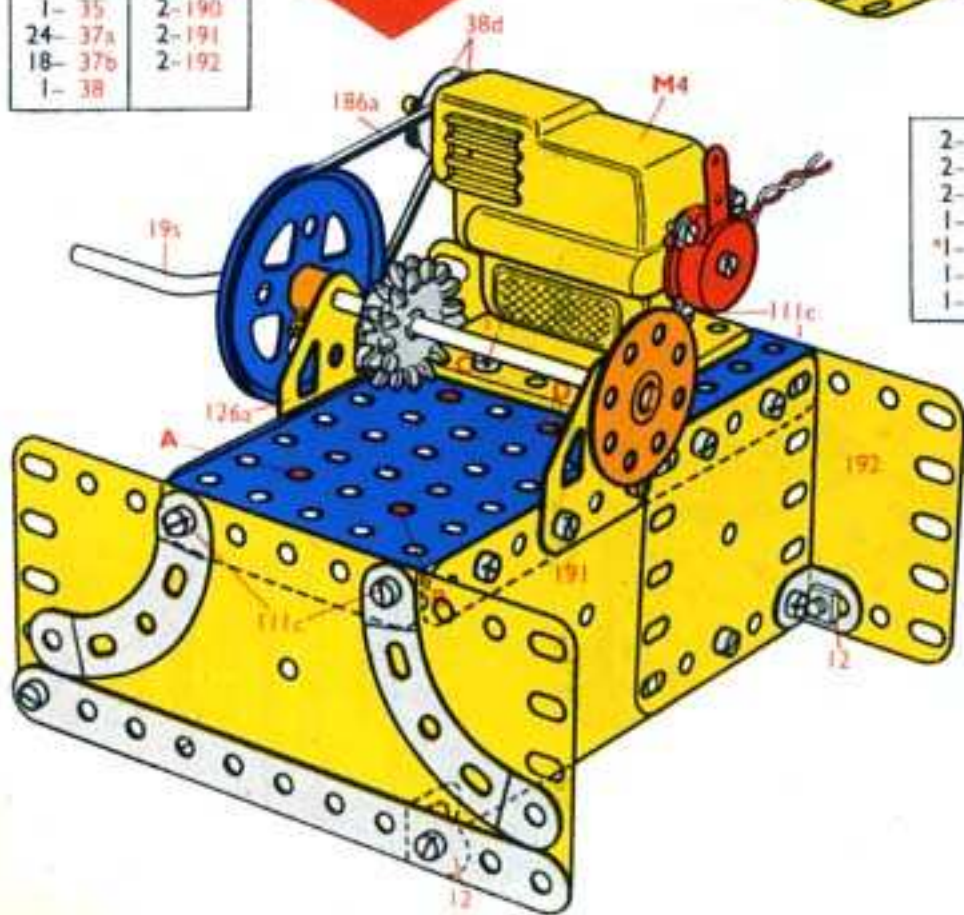

2- 1	12- 37a
2- 5	12- 37b
2- 17	4- 38
1- 22	2- 48a
*1- 23a	2- 126
1- 24	*1- 186
1- 27f	

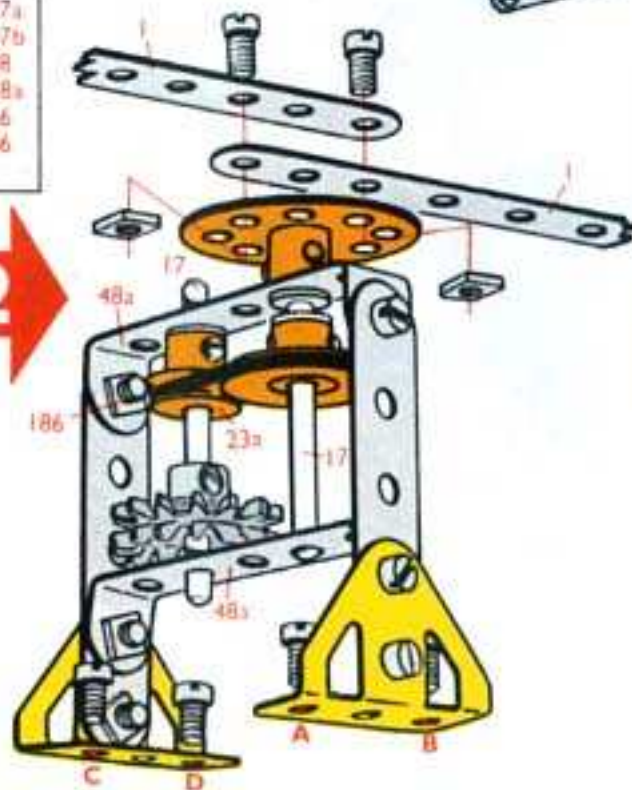

2- 1	2- 27f	2- 126
6- 2	1- 35	2- 126a
8- 5	61- 37a	2- 155
2- 10	55- 37b	1- 186
2- 11	5- 38	*1- 186a
10- 12	2- 38d	2- 189
2- 17	2- 48a	2- 190
1- 19a	1- 52	2- 191
1- 20a	4- 90a	2- 192
1- 22	6- 111c	4- 221
2- 22a	2- 125	*1- M4
*1- 23a		
2- 24		

\*Not included in set No. 4

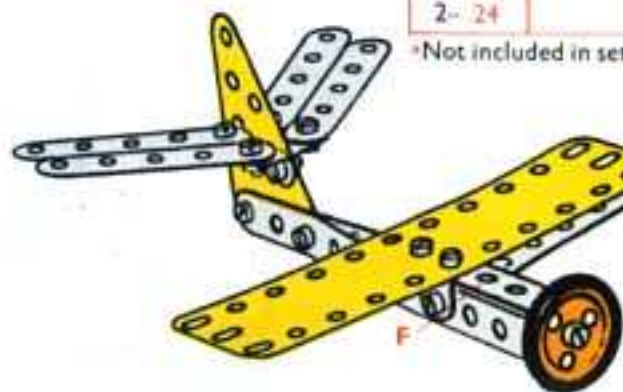

2- 2	12- 37b
1- 5	1- 125
1- 11	1- 155
5- 12	1- 189
1- 22a	3- 221
12- 37a	

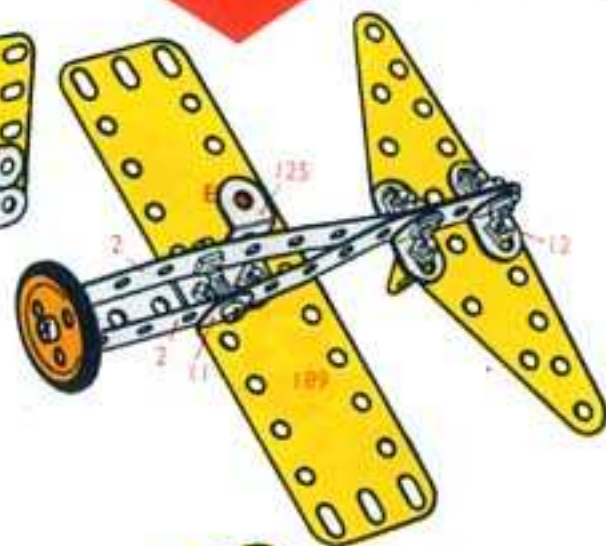

2- 2	
5- 5	
2- 10	
1- 11	
3- 12	
1- 32a	
13- 37a	
13- 37b	
1- 125	
1- 155	
1- 189	
1- 221	

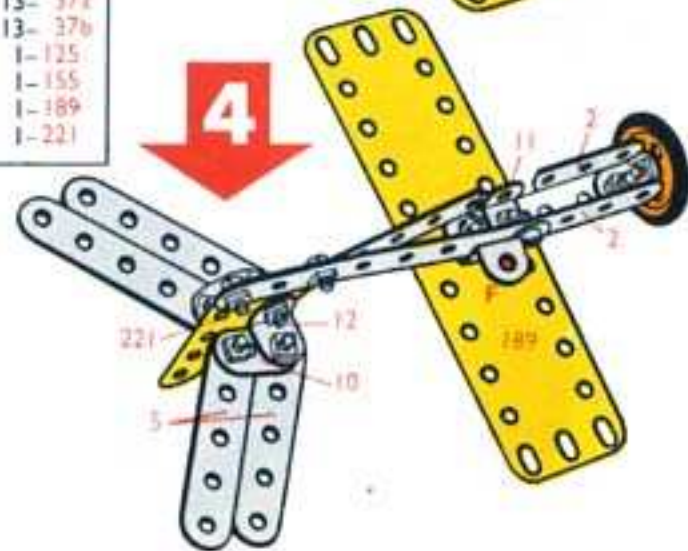

## 4.2.

Monotower Crane  
 Mono-torénkraan  
 Grue monotour  
 Gru a una torre  
 Turmdrehkran  
 Tornkran  
 Grúa de torre  
 Grua  
 Kran

2- 1	2- 22a	1- 57c
6- 2	1- 23	4- 90a
9- 5	2- 24	5-111c
2-11	2- 27f	2-126
9-12	8- 35	2-126a
1-15b	64- 37a	1-176
3-16	56- 37b	1-188
2-17	9- 38	2-189
1-18b	2- 38d	2-192
1-19a	1- 40	1-212
1-20a	2- 48a	2-214
4- 22	1- 52	2-221

2- 5	2- 35
1-11	13- 37a
1-12	9- 37b
1-15b	7- 38
2-16	2- 38d
1-17	2- 48a
1-20a	1- 52
4-22	3-111c
2-27f	2-192

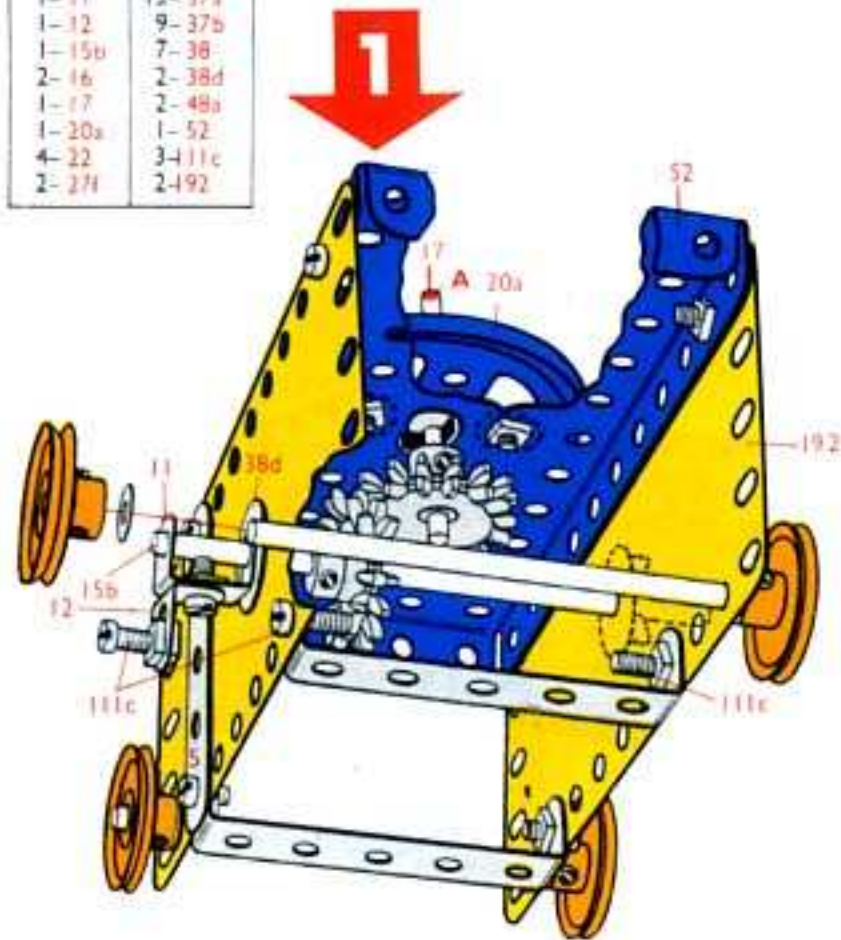

2- 1	2- 38
4- 2	1- 40
3- 5	4- 90a
4-12	2-126
1-16	2-126a
1-19a	1-176
2-24	2-189
2-35	1-212
27-37a	2-214
27-37b	

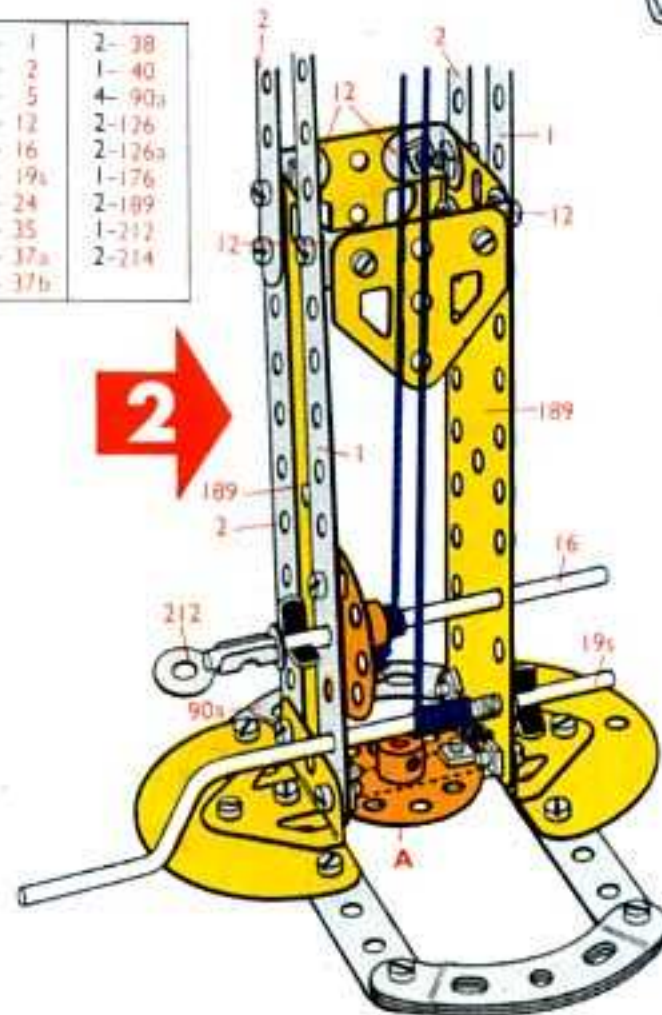

2- 2
4- 5
1-11
4-12
1-17
1-18b
2-22a
1-23
4-35
24-37a
20-37
1-57c
2-111c
1-188
2-221

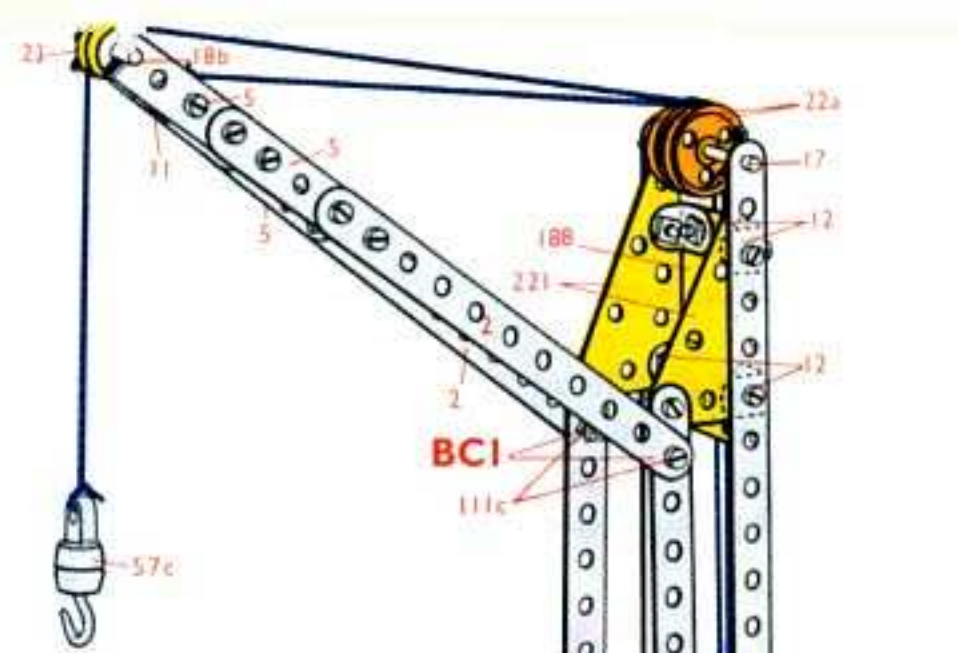
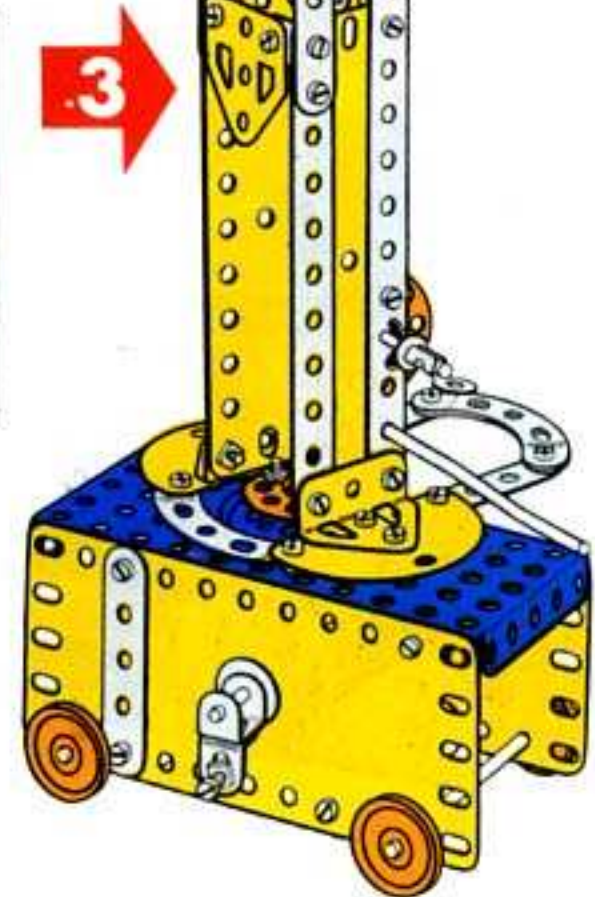

## 4.3.

Elevated Platform Lorry

Vrachtwagen met laadplatform

Camion à plateforme surélevée

Autocarro a pianale elevato

Hochlader

Lastbil med höjd plattform

Camión de plataforma elevada

Grande Camião com plataforma

Lastebil med hevbar arbeidsplattform

6	2	2-22a	2-90a	1-191
8	5	2-24	6-111c	2-192
4	10	6-35	1-125	2-193
2	11	57-37a	2-126	2-194
10	12	39-37b	2-126a	1-194a
2	15b	9-38	4-142c	1-199
2	16	2-38d	2-155	1-212
1	18a	1-40	2-188	1-214
1	19s	2-48a	1-189	1-221
4	22	1-52	2-190	

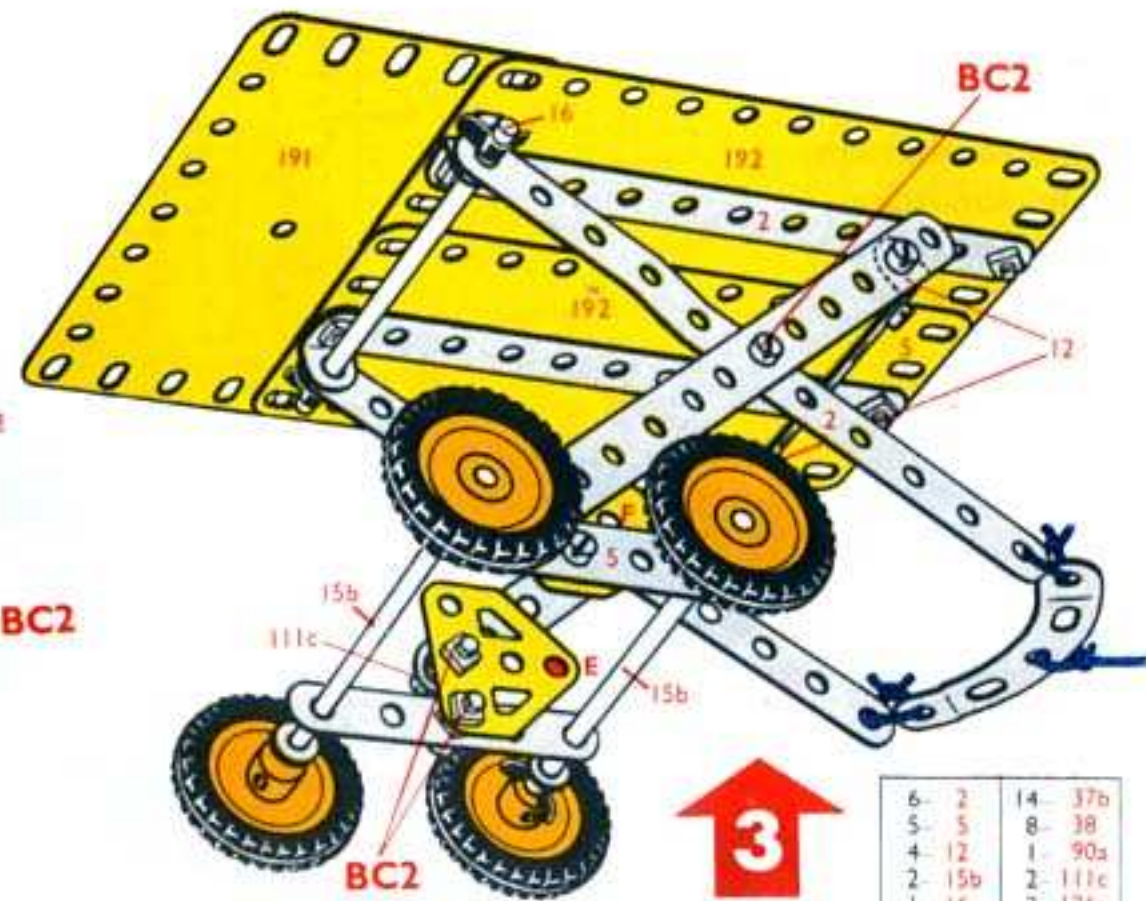

6	2	14	37b
5	5	8	38
4	12	1	90a
2	15b	2	111c
1	16	2	126a
4	22	4	142c
6	35	1	191
22	37a	2	192

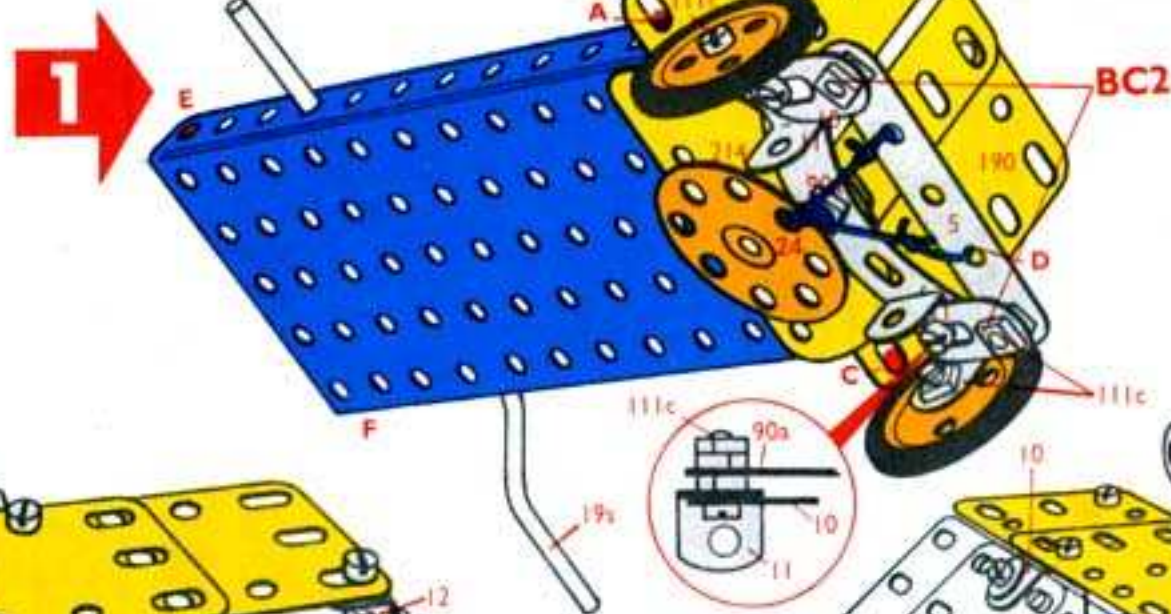

2	5	1	125
2	10	2	126
6	12	2	188
1	18a	1	189
1	24	2	193
17	37a	2	194
17	37b	1	194a
1	38	1	199
2	38d	1	212
2	48a	1	221

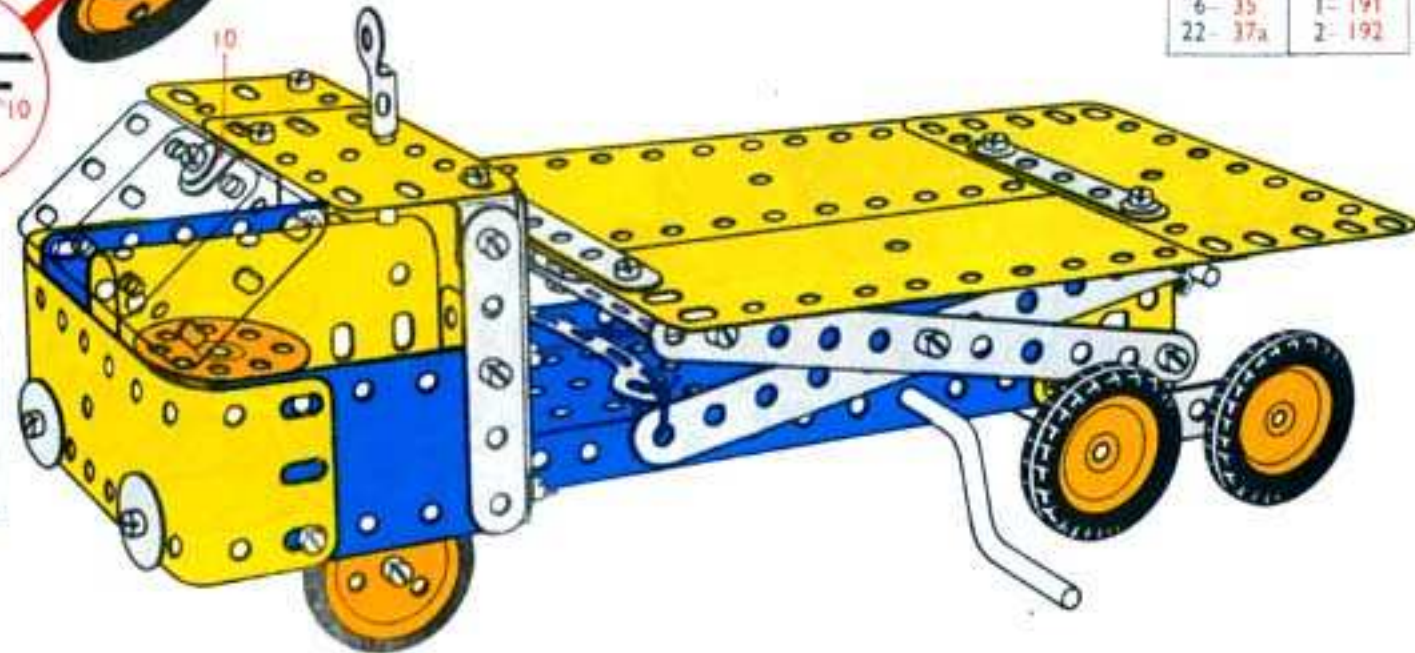

1	5
2	10
2	11
1	16
1	19s
2	22a
1	24
18	37a
6	37b
1	40
1	52
1	90a
4	111c
2	155
1	176
2	190
1	214

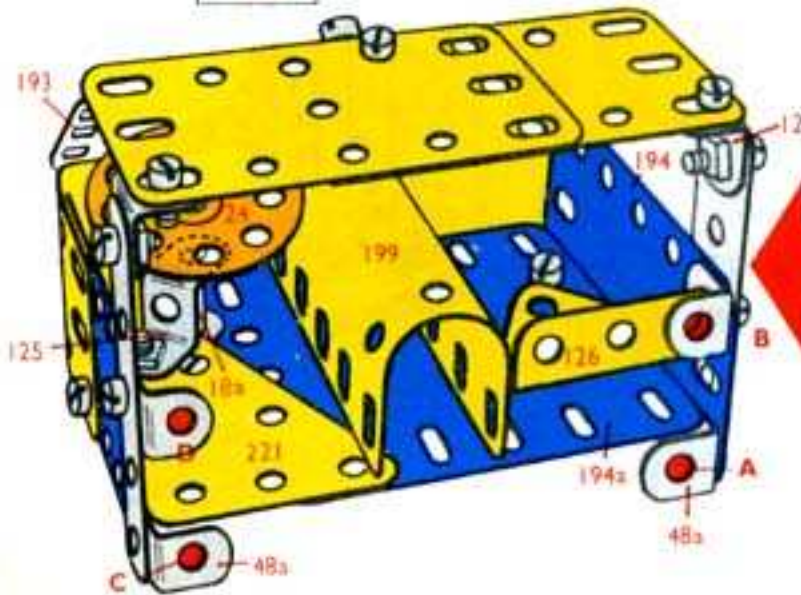

4.4.

Gantry Crane  
 Loopkraan  
 Grue à portique  
 Gru a cavalletto  
 Brückenkran  
 Portalkran  
 Grúa de pórtico  
 Guindaste de pórtico

2	1	4	22	4	90a
6	2	1	22a	2	111c
9	5	1	23	2	125
2	10	2	24	2	126
2	11	10	35	2	126a
7	12	57	37a	1	176
1	15b	53	37b	2	189
3	16	10	38	1	192
2	17	1	40	1	200
1	18b	2	48a	2	215
1	19a	1	52	2	221
1	20a	1	57c		

2	1	26	37b
1	2	2	38
4	5	1	52
2	11	2	90a
6	12	1	111c
1	15b	2	126a
1	19a	1	176
1	20a	1	200
2	24	2	215
2	35	2	221
28	37a		

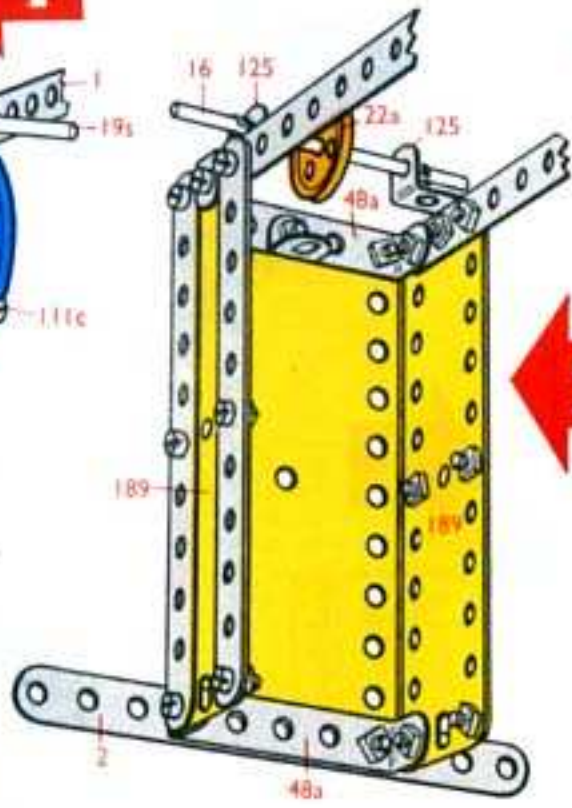
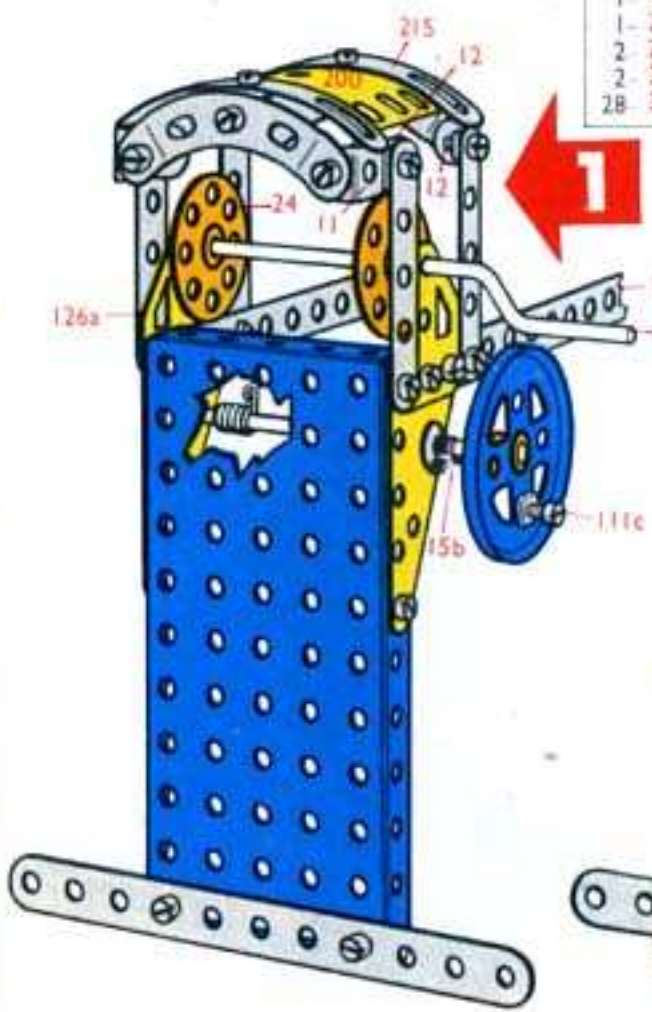
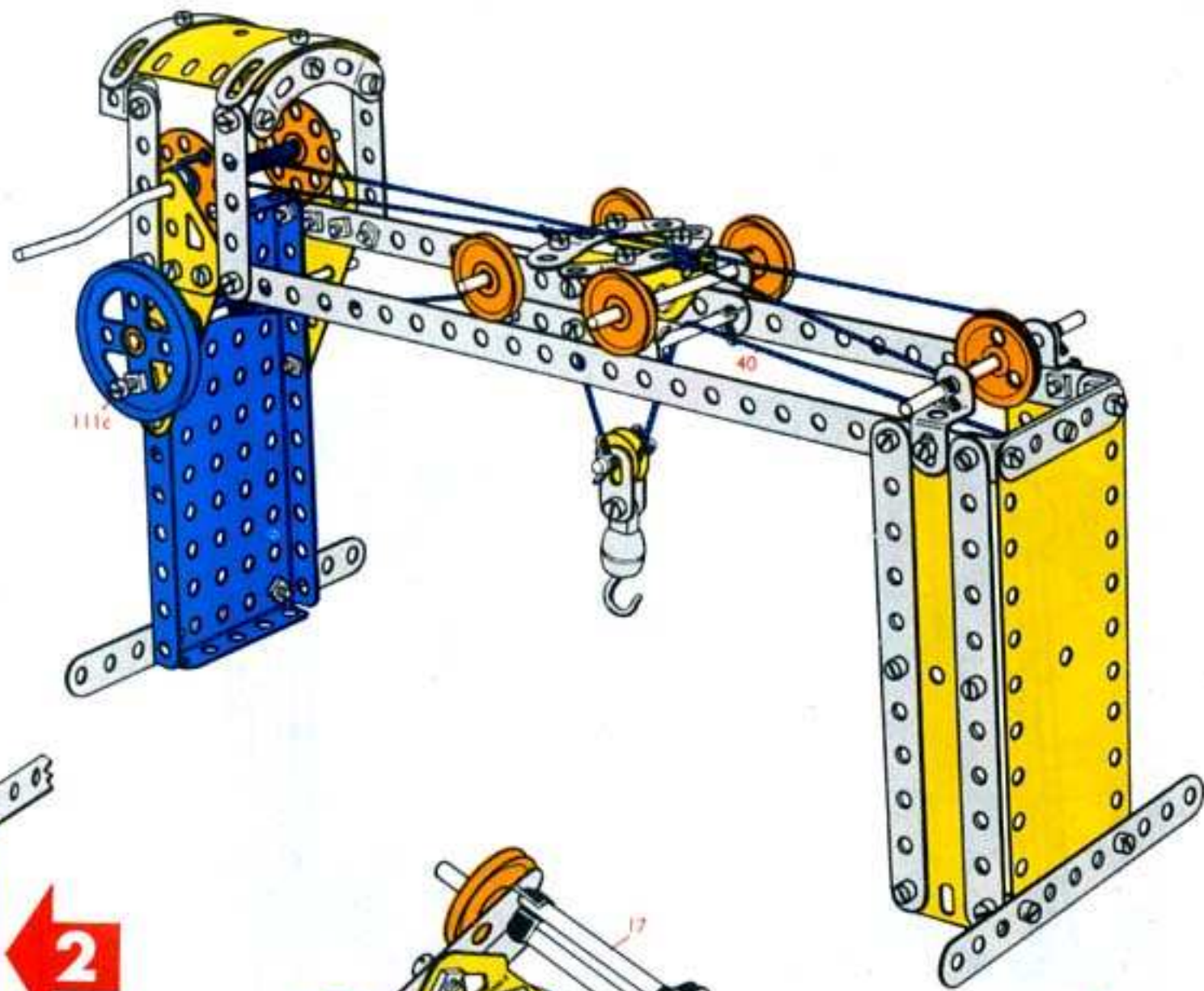

5	2
1	5
1	12
1	16
1	22a
2	35
19	37a
19	37b
2	48a
2	125
2	189
1	192

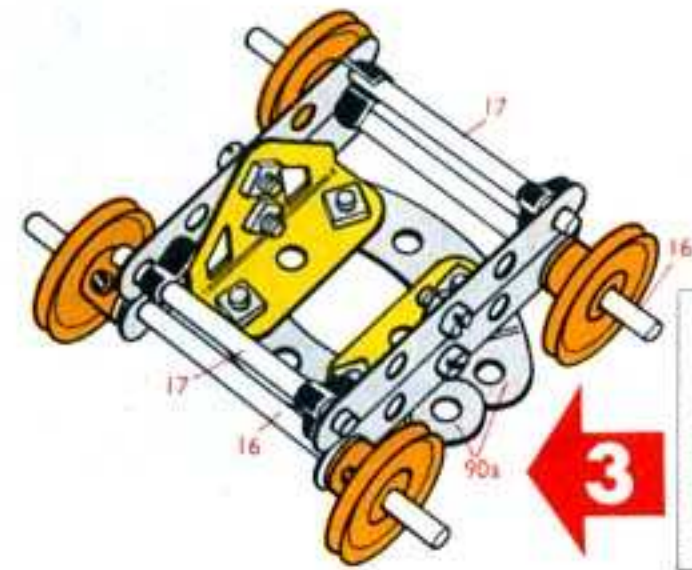

4	5
2	16
2	17
4	22
4	35
8	37a
8	37b
8	38
2	90a
2	126



2	10
1	18b
1	23
2	35
2	37a
1	57c
1	111c

### 4.5.

## Platform Weighing Machine

- Bascule
- Pont à bascule
- Bascula
- Plattformwaage
- Plattformsvåg
- Báscula de plataforma
- Báscula com plataforma
- Plattformvekt

6- 2	62- 37a	2-189
8- 5	54- 37b	2-190
5-10	5- 38	2-191
1- 11	1- 40	1-192
6-12	2- 48a	2-193
2-15b	1- 52	2-194a
2-16	4-111c	1-199
2-17	2-125	1-200
1-18a	2-126	2-214
4-22	4-142c	2-221
2-22a	1-186	
4-35	2-188	

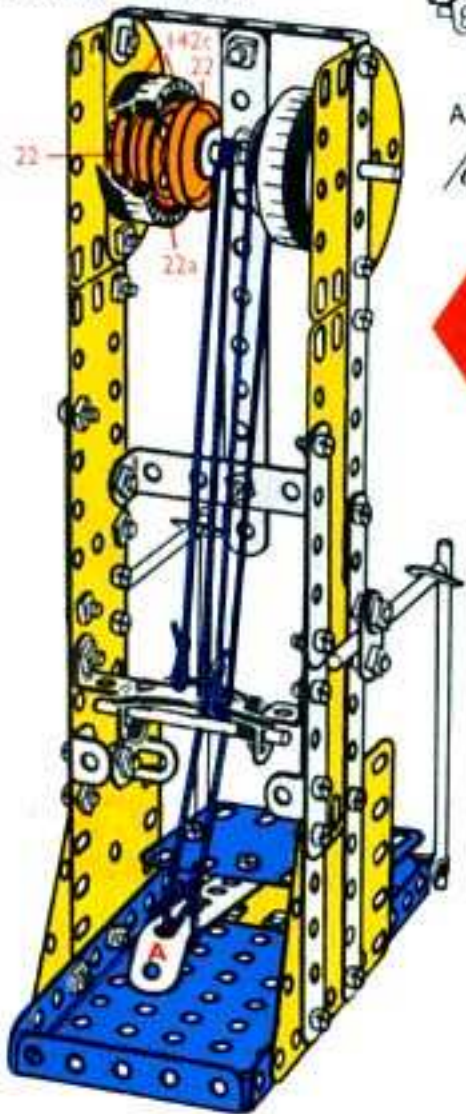
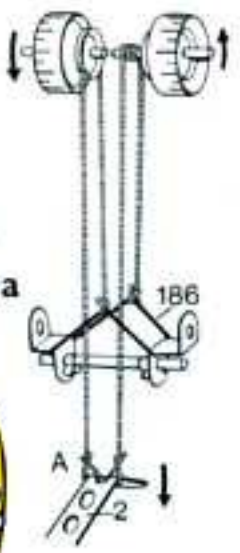

5- 2
6- 5
4-10
1-11
5-12
2-16
2-17
1-18a
4-22
2-22a
2-35
35-37a
27-37b
2-38
1-40
2-48a
4-111c
2-125
4-142c
1-186
2-188
2-189
2-190
2-214
2-221

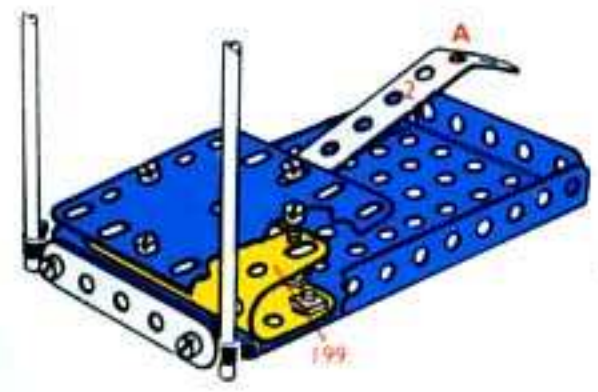

1- 2
1- 5
2-15b
2-35
8-37a
8-37b
1-52
1-194a
1-199

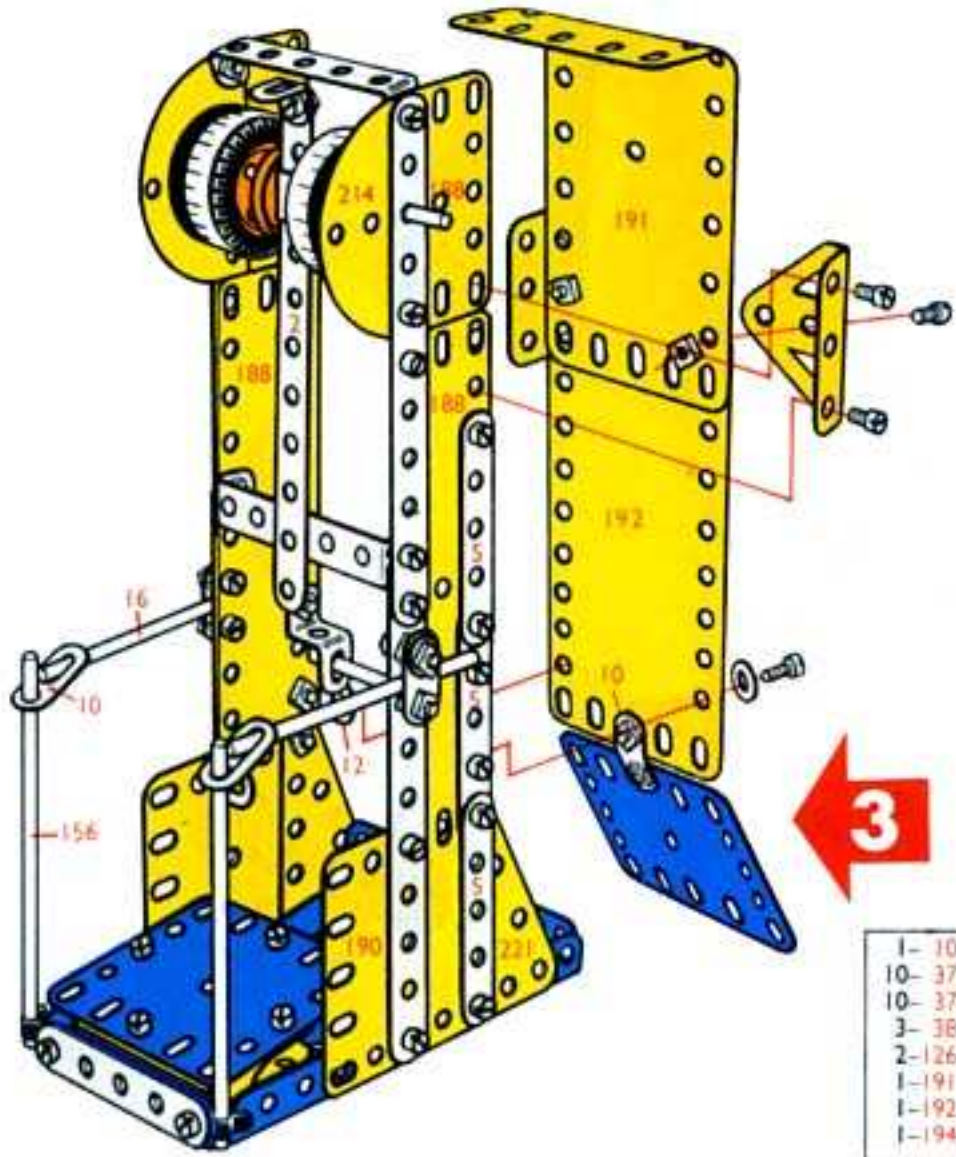

1- 10
10-37a
10-37b
3- 38
2-126
1-191
1-192
1-194a



1- 5
1-12
9-37a
9-37b
1-191
2-193
2-194
1-200

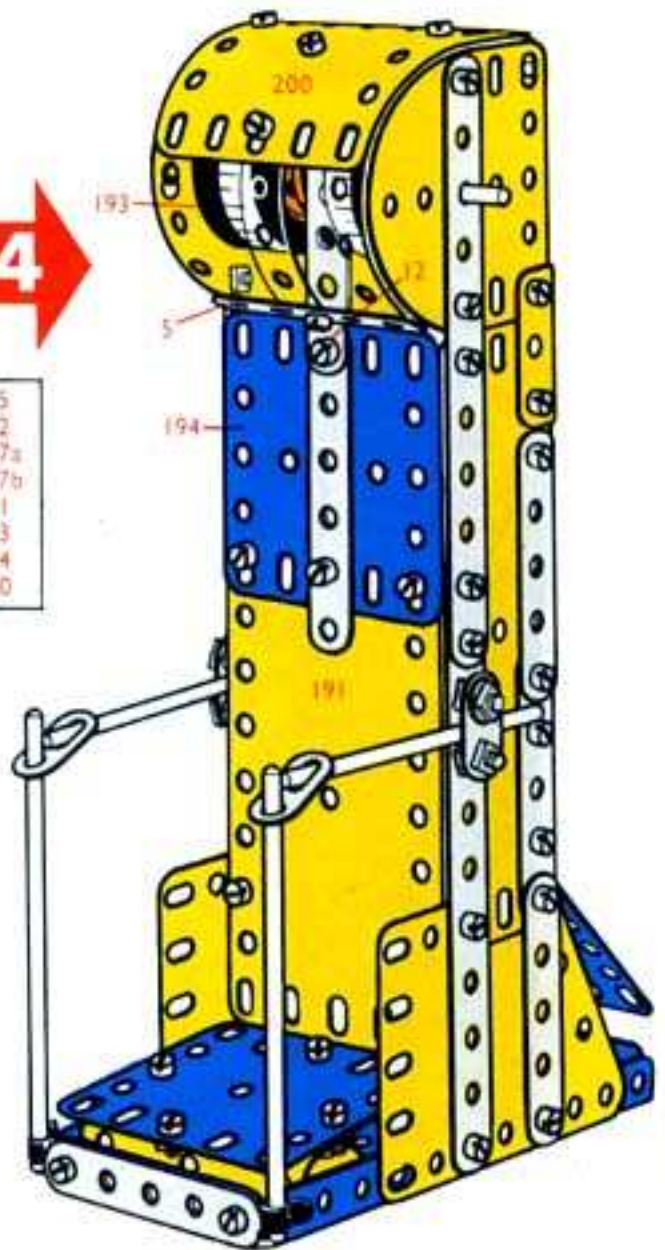

### 4.6.

Kangaroo  
 Kangoeroe  
 Kangourou  
 Canguro  
 Känguruh  
 Canguru  
 Kenguru

6- 2	44- 37a	1-126a
9- 5	44- 37a	1-189
2-10	2- 38	1-192
2-11	2- 48a	1-199
6-12	1- 52	1-200
1-16	2- 90a	2-215
2-22	2-126	3-221

2- 2	2- 48a
9- 5	1- 52
1-11	2- 90a
6-12	2-126
1-16	1-126a
2-22	1-189
34-37a	1-192
34-37b	1-200
2- 38	1-215
1-38d	1-221

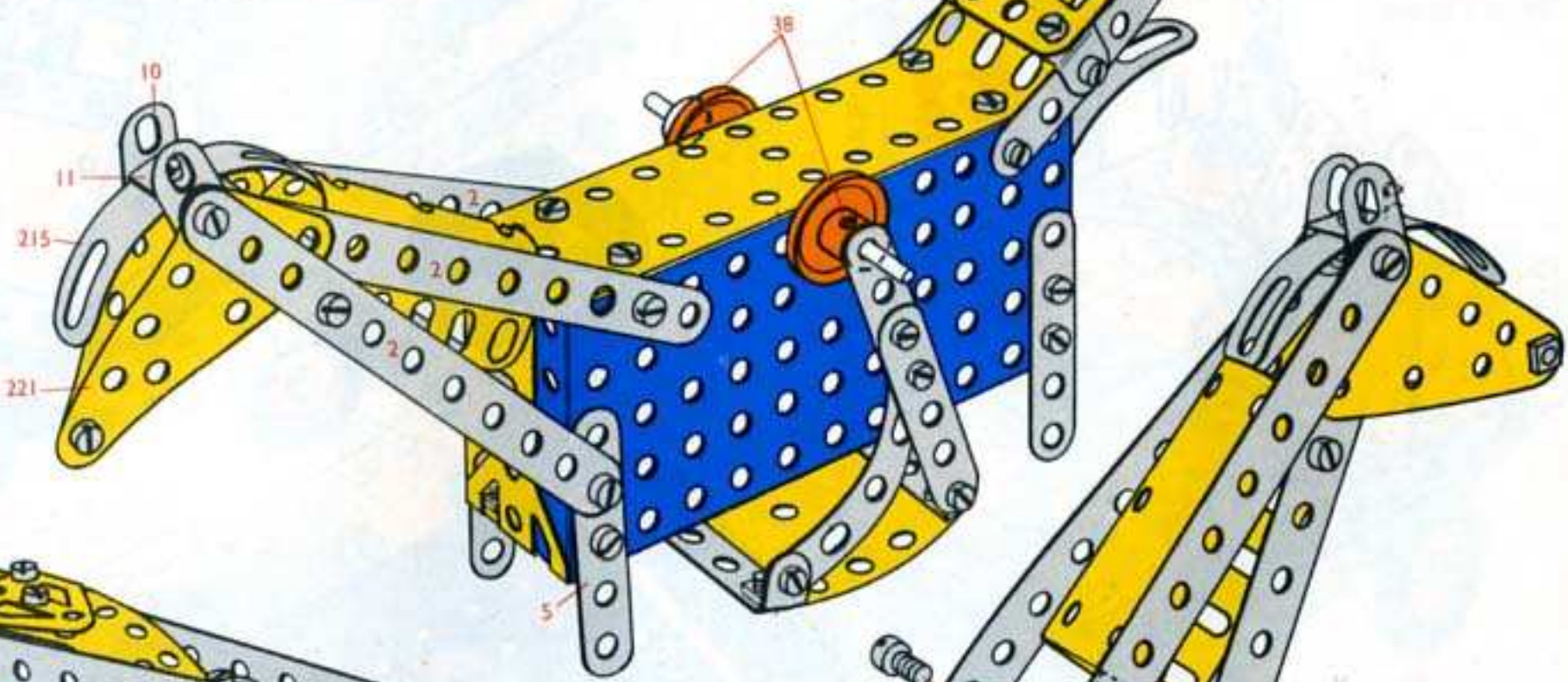
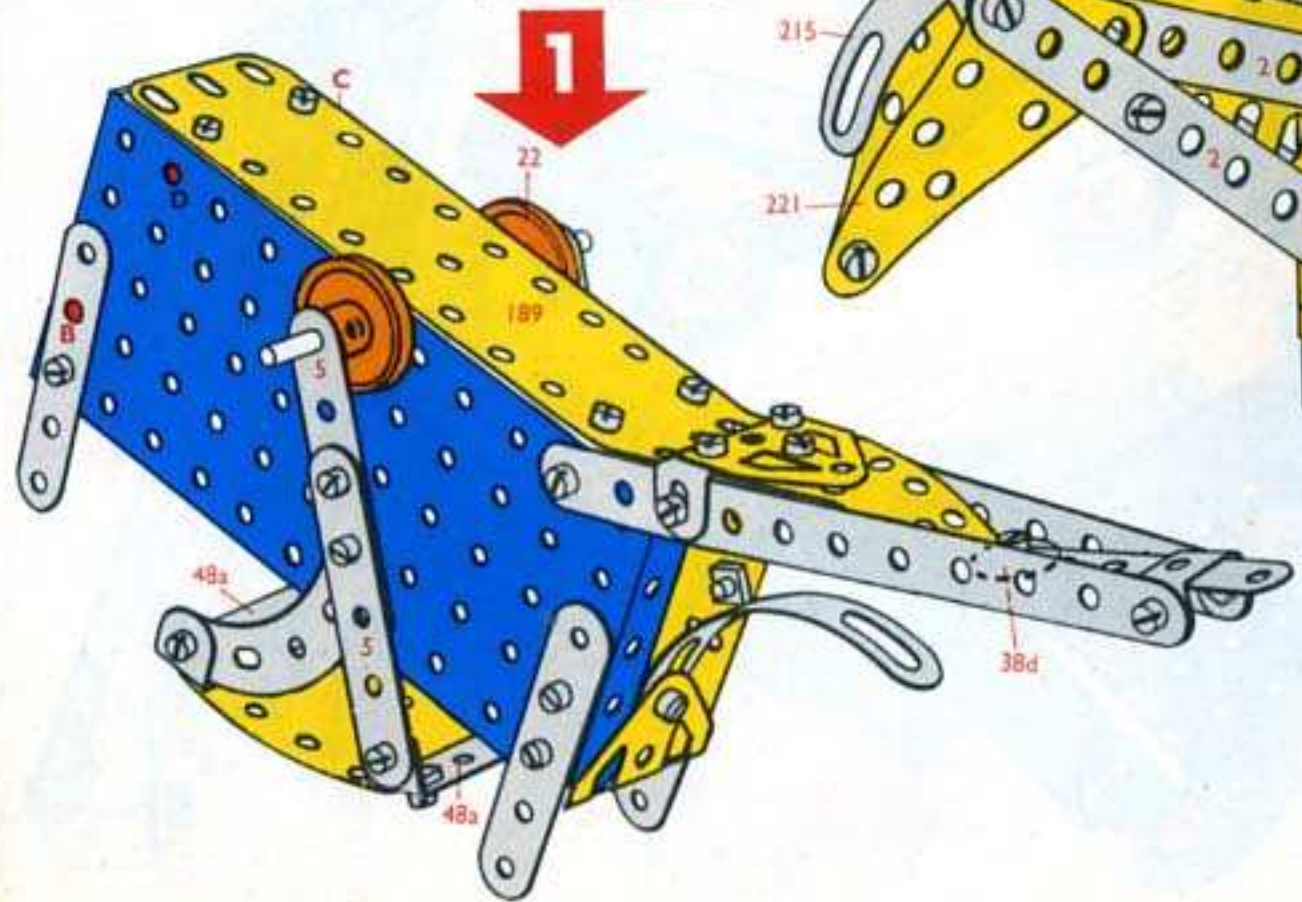
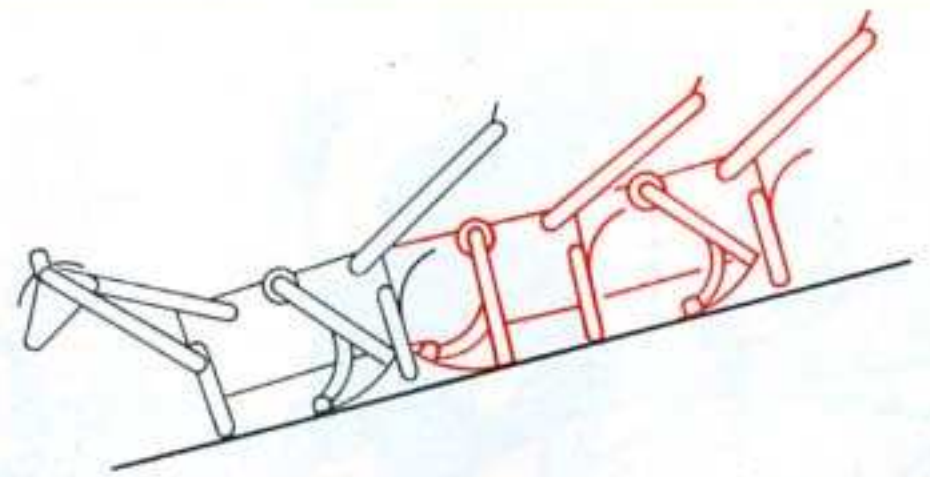

4- 2
2-10
1-11
10-37a
10-37b
1-199
1-215
2-221



## 4.7.

Mobile Crane

Mobiele kraan

Grue mobile

Gru semovente

Fahrkran

Mobilkran

Grúa móvil

Guindaste móvel

Mobil kran

2- 1	1- 19a	1- 40	1-176
6- 2	1- 20a	2- 48a	2- 188
9- 5	4- 22	1- 52	2-189
2-10	1- 23	1- 57c	1-190
2-11	2- 24	2- 90a	2-191
10-12	10- 35	6-111c	1-200
2-16	62- 37a	2-125	1-212
1-17	56- 37b	2-126	1-214
1-18a	3- 38	2-126a	2-215
1-18b	2- 38d	4-142c	4-221

1- 18b
1- 23
2- 35
2- 37a
2- 37b
1- 40
1- 57c

2- 2	2-111c
7- 5	2-125
1-11	2-126
8-12	2-126a
1-17	1-176
1-19a	2-188
1-24	1-190
2-35	2-191
38-37a	1-200
36-37b	1-212
2-38	1-214
2-48a	2-215
2-90a	2-221

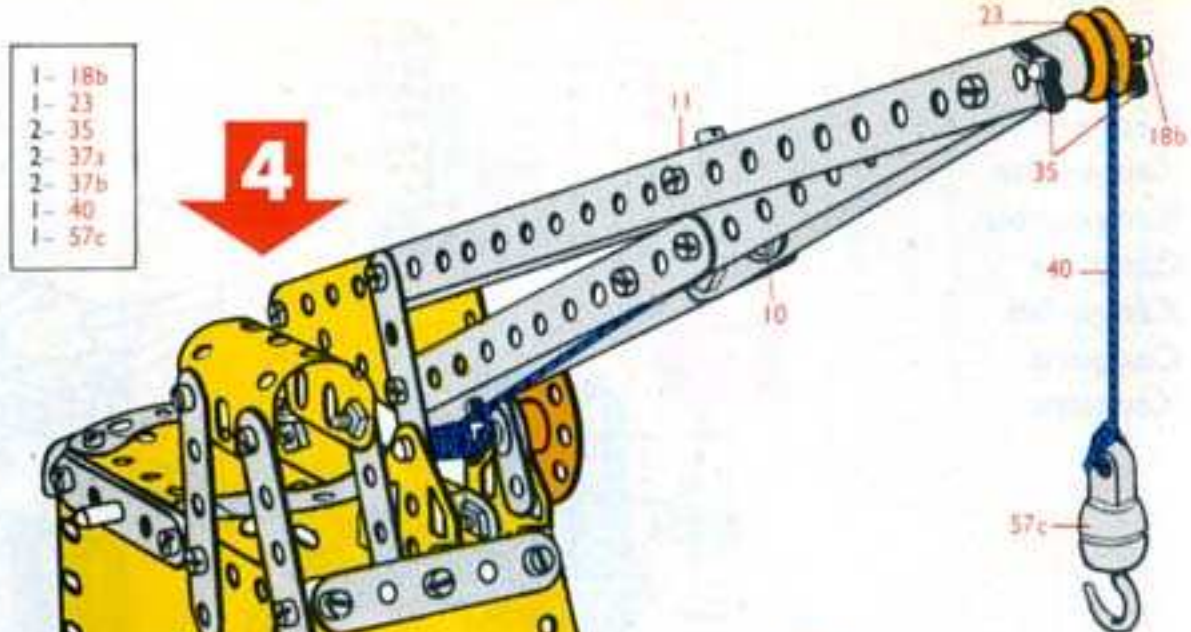
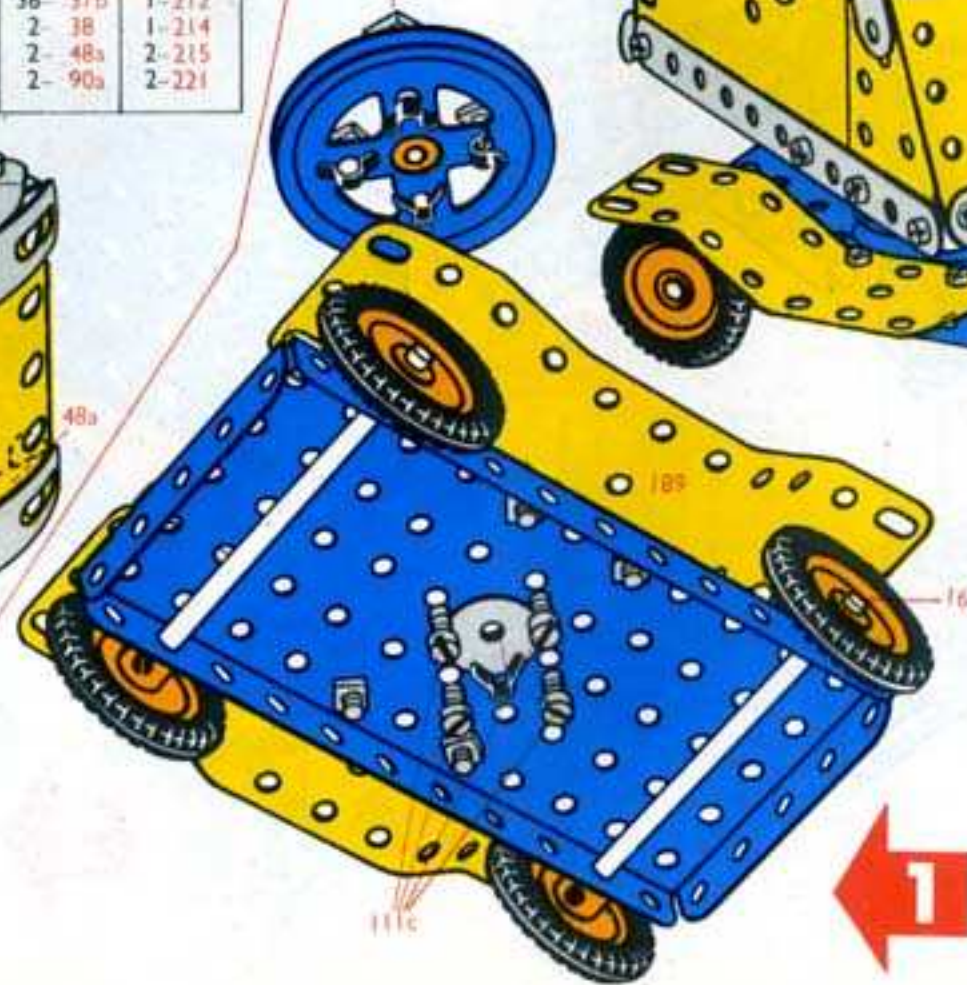

2- 1
4- 2
2- 5
2-10
1-11
2-12
1-18a
1-24
1-35
14-37a
14-37b
1-38
1-38d
2-221

2- 16
1- 20a
4- 22
5- 35
8- 37a
4- 37b
1- 38d
1- 52
4-111c
4-142c
2-189



4.8.

Heavy Tipping Lorry

Zware kipwagen

Camion poids lourd

à benne basculante

Ribaltabile per servizio pesante

Schwerkipplaster

Tung tipplastvagn

Camión basculante pesado

Grande Camião basculante

Tung tipplastebil

4	2	2	27f	4	142c
9	5	4	35	1	155
3	10	73	37a	2	188
2	11	61	37b	2	189
10	12	10	38	2	190
2	16	2	38d	1	191
1	18a	2	48a	2	192
1	18b	1	52	1	194
1	19a	4	90a	1	199
1	20a	6	111c	2	214
3	22	2	125	4	221
2	22a	2	126		
2	24	2	126a		

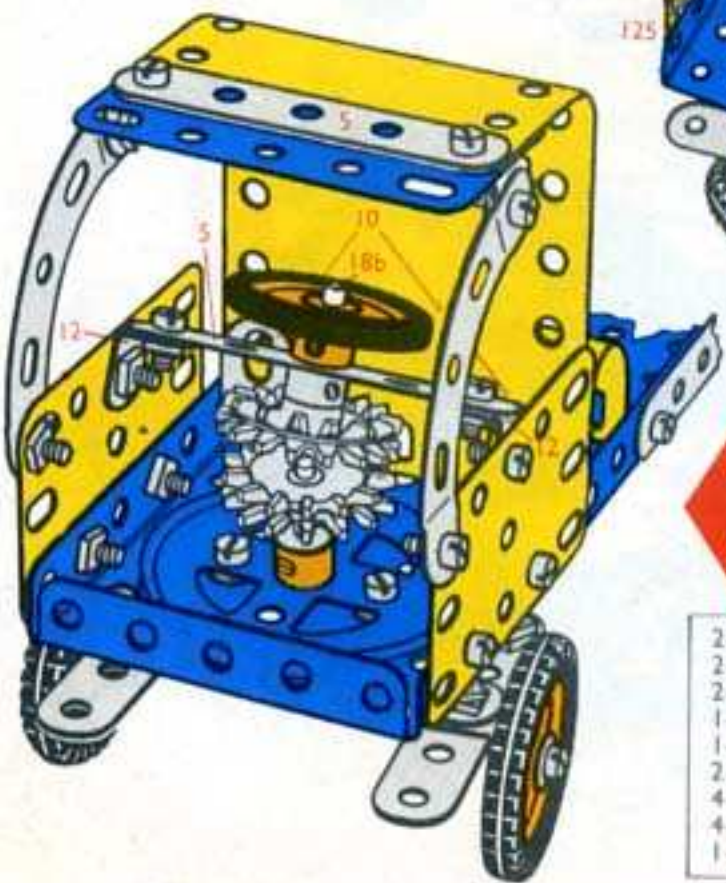

2

2	5
2	10
2	12
1	18b
1	22
2	27f
4	37a
4	37b
1	155



1

2	2	25	37b
3	5	4	38
1	10	1	48a
2	11	1	52
2	12	3	90a
1	16	6	111c
1	18a	2	125
1	19a	2	126
1	20a	2	126a
2	22	4	142c
2	22a	2	188
2	24	1	191
2	35	1	194
37	37a	1	199

4

2	37a
2	37b
2	38d
1	190

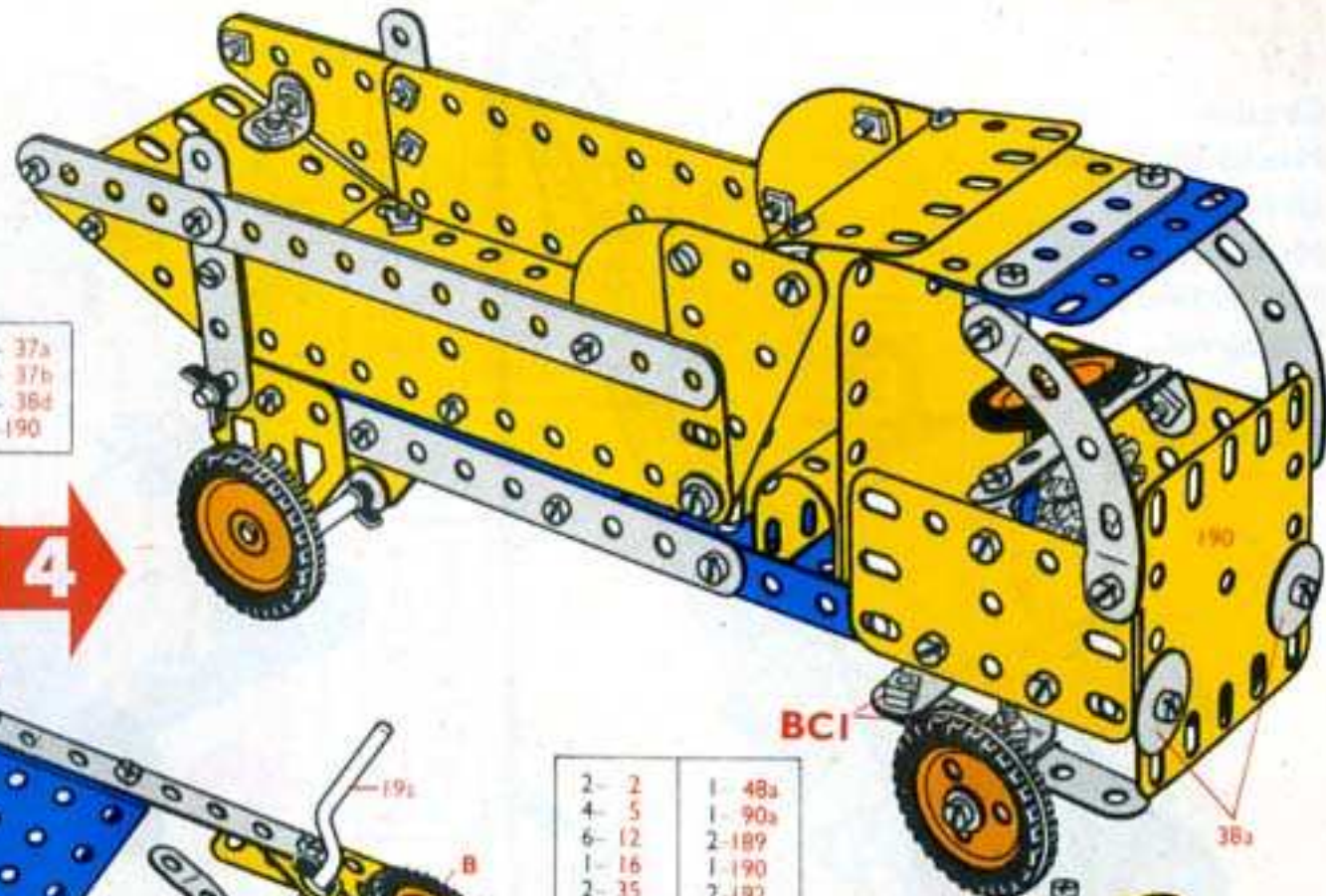

3

2	2	1	48a
4	5	1	90a
6	12	2	189
1	16	1	190
2	35	2	192
30	37a	2	214
30	37b	4	221
6	38		

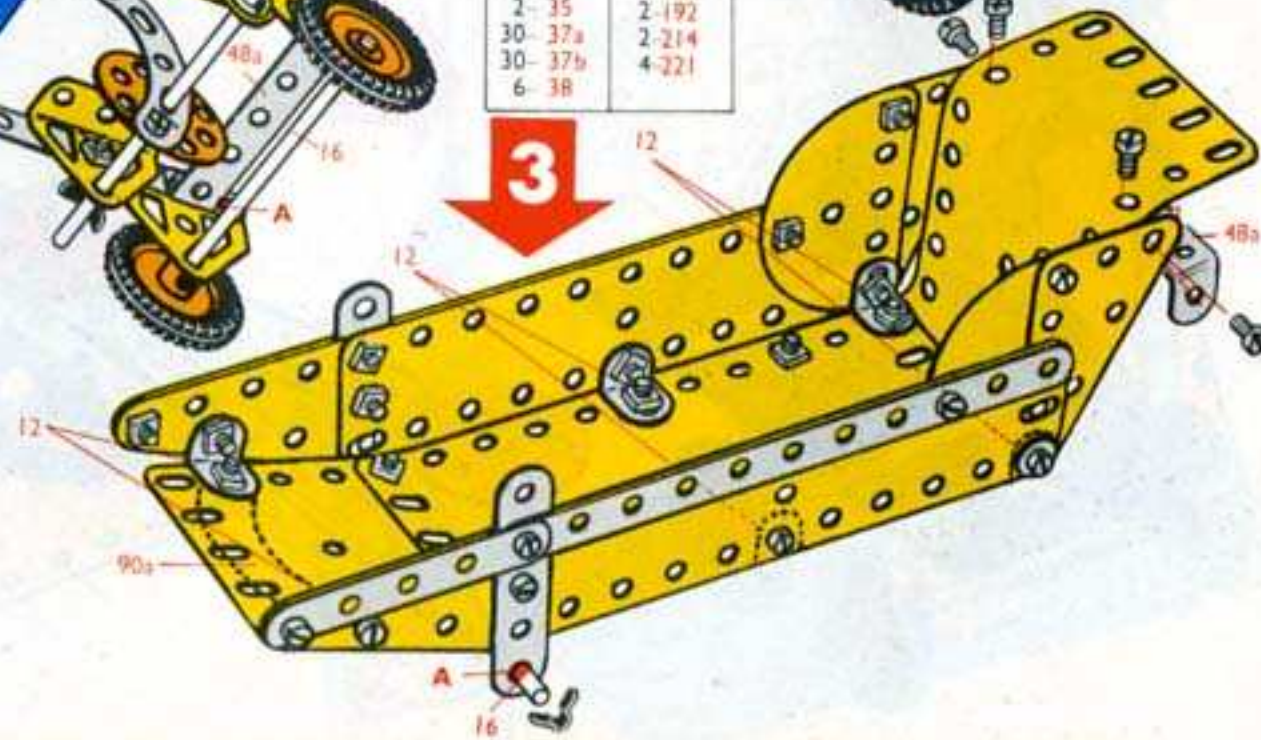

### 4.9.

Grader  
 Mechanische schop  
 Niveleuse  
 Motolivellatore  
 Planierfahrzeug  
 Väghyvel  
 Niveladora  
 Veiskrape

6-	2	7	35	4	142c
9-	5	60	37a	2	155
2-	11	58-	37b	1	176
10-	12	10	38	1	186
2-	15b	2-	38d	1	189
3-	16	1-	40	2	190
1-	18b	2-	48a	2	191
1-	19s	1-	52	2	193
1-	20a	2-	90a	1	194a
4-	22	1-	111c	1	212
2-	22a	1-	125	1	214
1-	23	2-	126	2	221
2-	24	1-	126a		

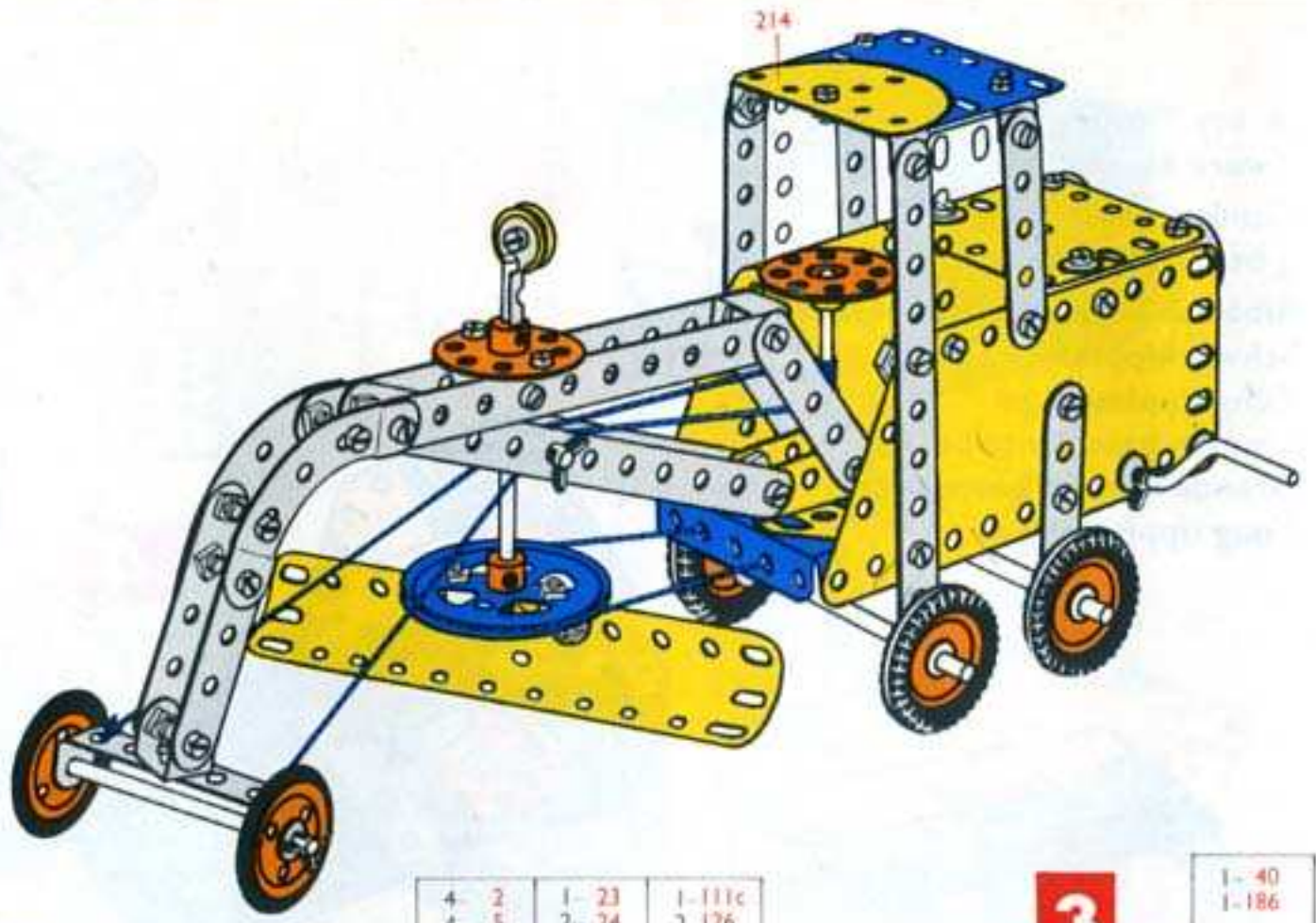

2-	2	1-	48a
5-	5	1-	52
6-	12	1-	125
2-	15b	1-	126a
1-	19s	4-	142c
4-	22	2-	190
2-	35	2-	191
31-	37a	2-	193
31-	37b	1-	194a
6-	38	1-	214
2-	38d	2-	221

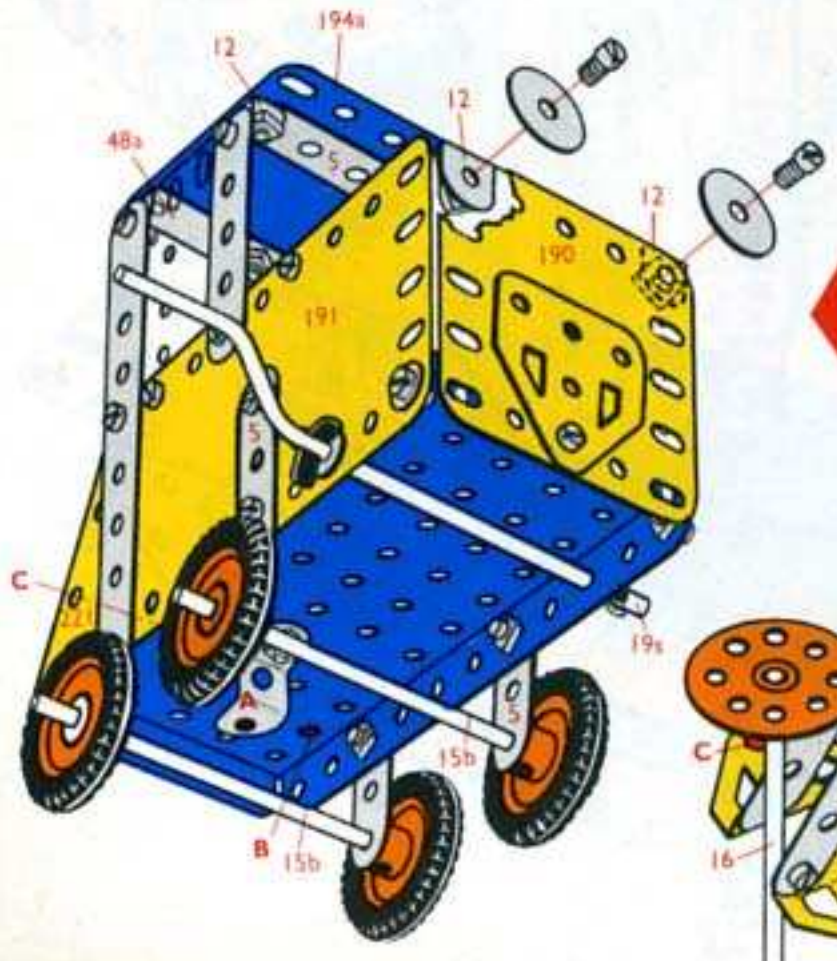

4-	2	1-	23	1-	111c
4-	5	2-	24	2-	126
2-	11	5-	35	2-	155
4-	12	29-	37a	1-	176
3-	16	27-	37b	1-	189
1-	18b	4-	38	1-	212
1-	20a	1-	48a		
2-	22a	2-	90a		

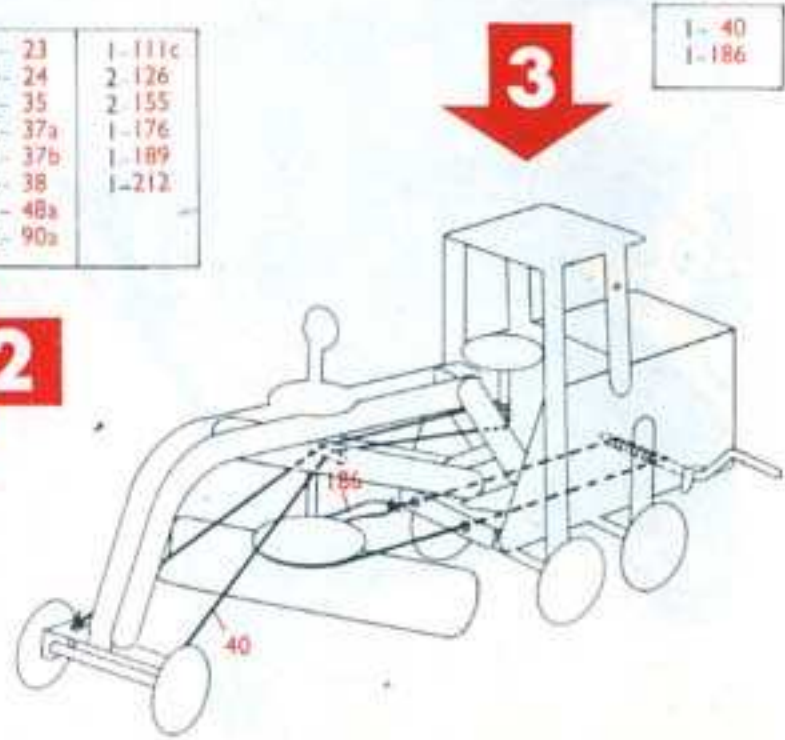
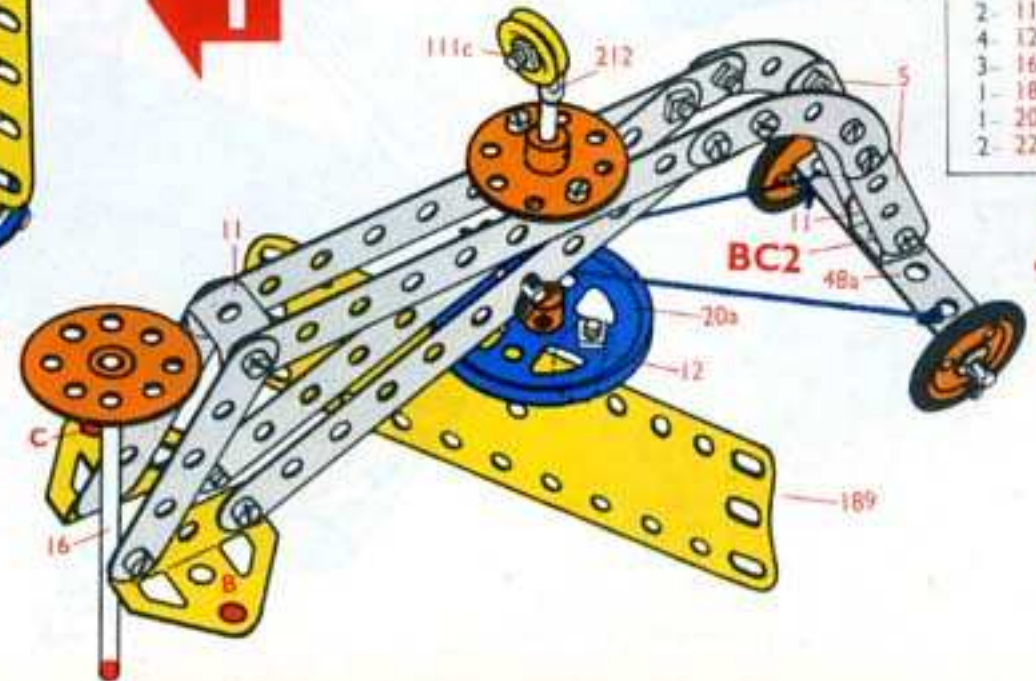

1-	40
1-	186

4.10.

Horizontal Steam Engine  
 Horizontale stoommachine  
 Machine à vapeur horizontale  
 Caldaia a vapore orizzontale  
 Waagrechte Dampmaschine  
 Horizontalångmaskin  
 Máquina de vapor horizontal  
 Horizontal dampmaskin

2- 1	1- 20a	1- 52	2-191
6- 2	3- 22	1- 57c	2-192
9- 5	1- 22a	4- 90a	2-194
5-10	1- 23	3-111c	2-194a
2-11	2- 24	1-125	1-199
8-12	2- 27f	2-126	1-200
2-15b	7- 35	1-126a	1-212
2-16	71-37a	1-155	1-213
1-17	60-37b	1-176	2-214
1-18a	9- 38	2-188	4-215
1-18b	1- 40	2-189	4-221
1-19s	2- 48a	2-190	

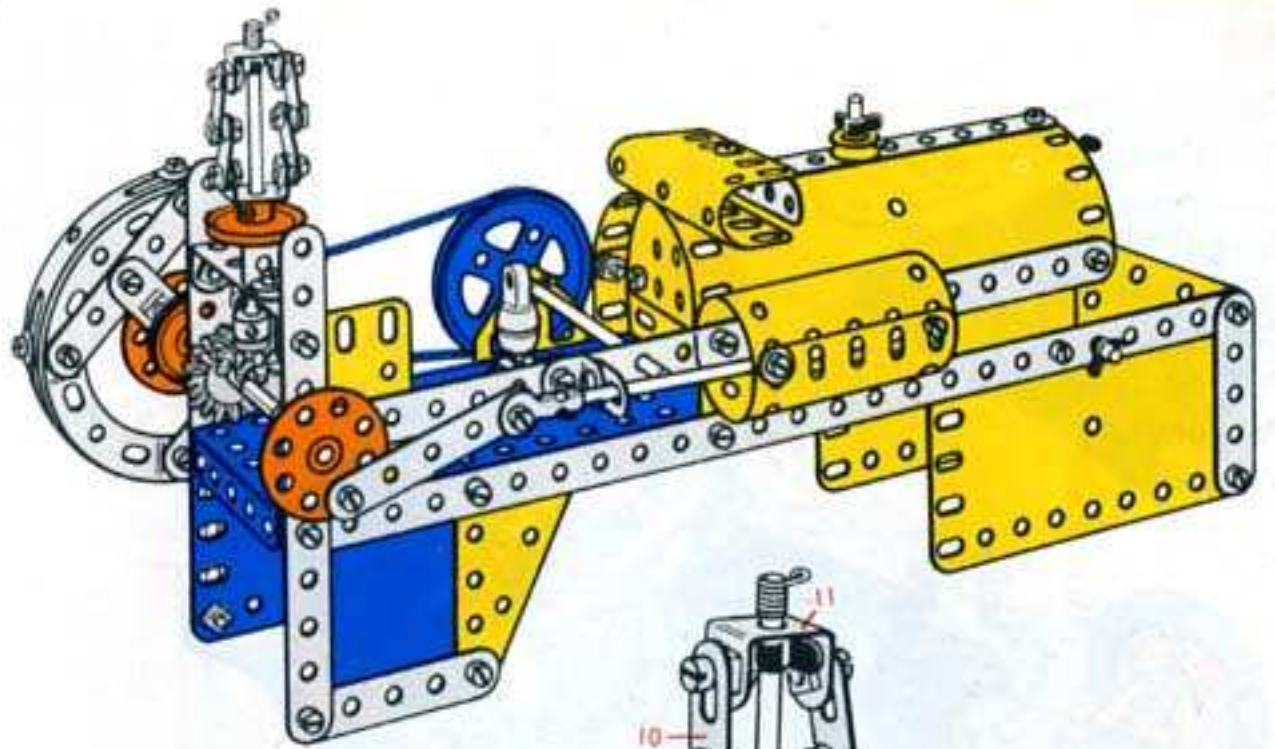

3- 2
1- 5
3-12
1-18b
1-22a
1- 23
2- 35
12-37a
12-37b
1- 48a
1-155
2-190
2-192
1-199
1-214

2- 1	1- 52
3- 2	1- 57c
4- 5	3-111c
1-10	1-125
3-12	2-126
1-15b	1-126a
1-16	2-188
1-17	2-189
1-20a	2-191
3- 35	2-194
31-37a	2-194a
28-37b	1-200
3- 38	1-214
1- 48a	4-221

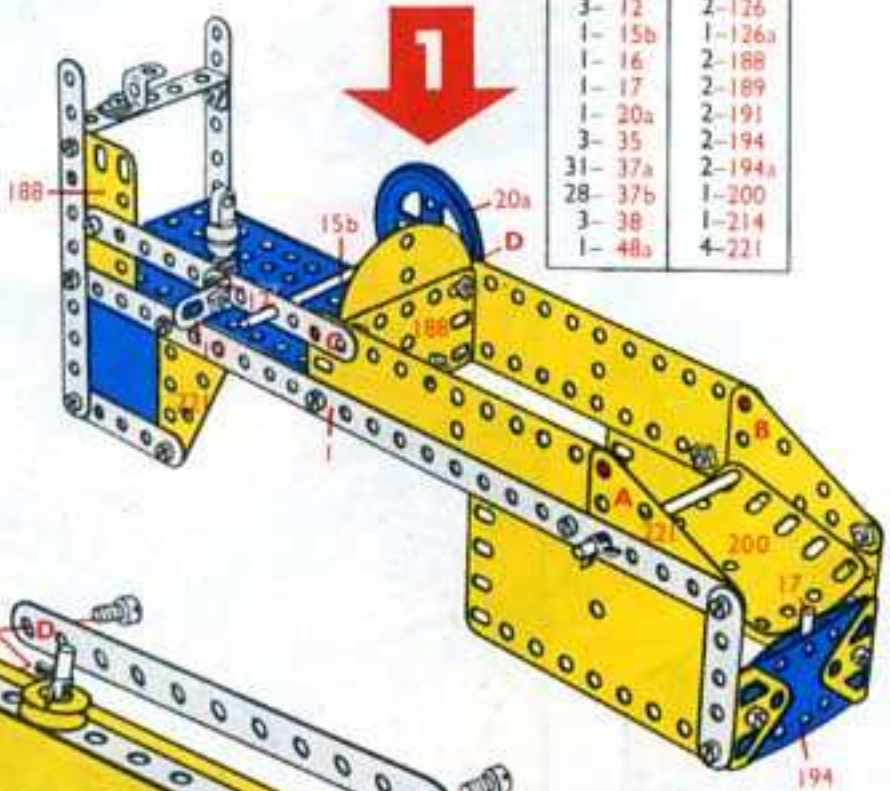

4- 5
4-10
2-11
2-12
1-15b
1-16
1-18a
1-19s
3- 22
2- 24
2- 27f
2- 35
28-37a
20-37b
6- 38
4- 90a
1-176
1-212
1-213
4-215

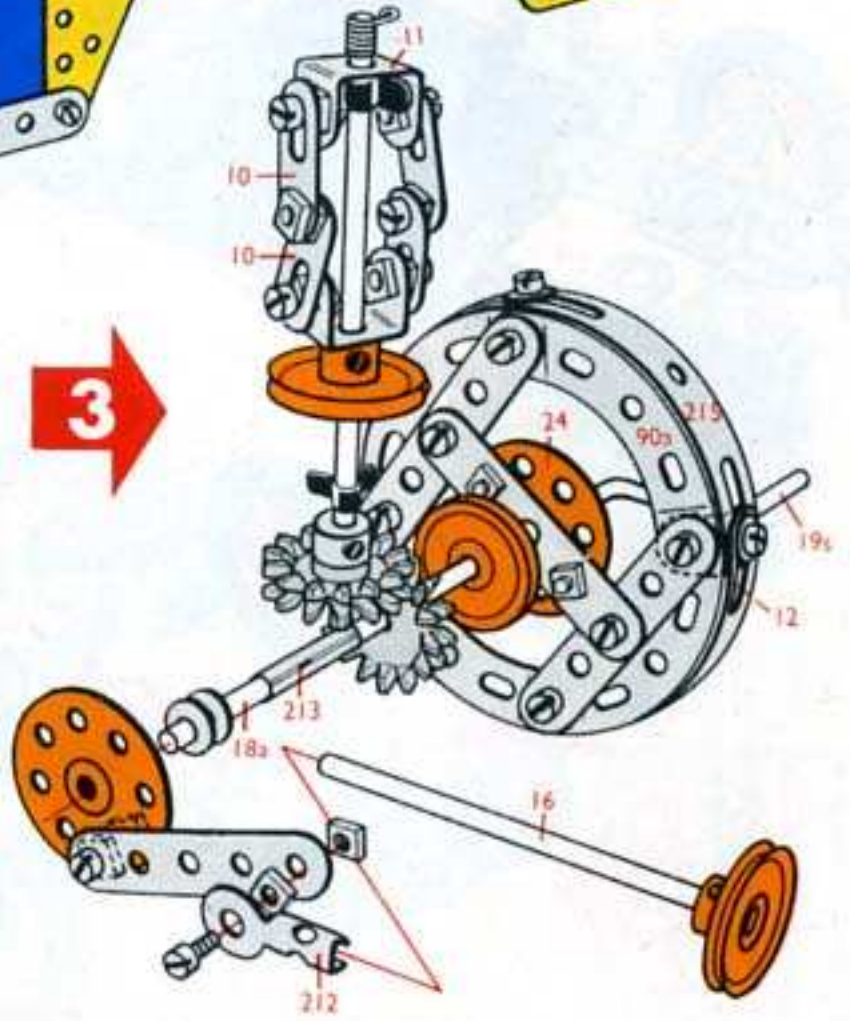

### 4.11.

Delivery Van  
 Bestelwagen  
 Camionnette  
 Furgoncino  
 Lieferfahrzeug  
 Skåpvagn  
 Furgón de reparto  
 Furgoneta  
 Varevogn

6	2	62	37b	2	188
9	5	10	38	2	189
3	10	2	38d	2	190
2	11	2	48a	2	191
4	12	1	52	2	192
2	16	4	90a	2	193
1	18a	4	111c	2	194
1	18b	2	125	2	194a
4	22	2	126	1	199
2	22a	2	126a	1	212
1	24	4	142c	1	214
3	35	1	155	2	221
70	37a	*1	186a	*1	M1

\* Not included in set

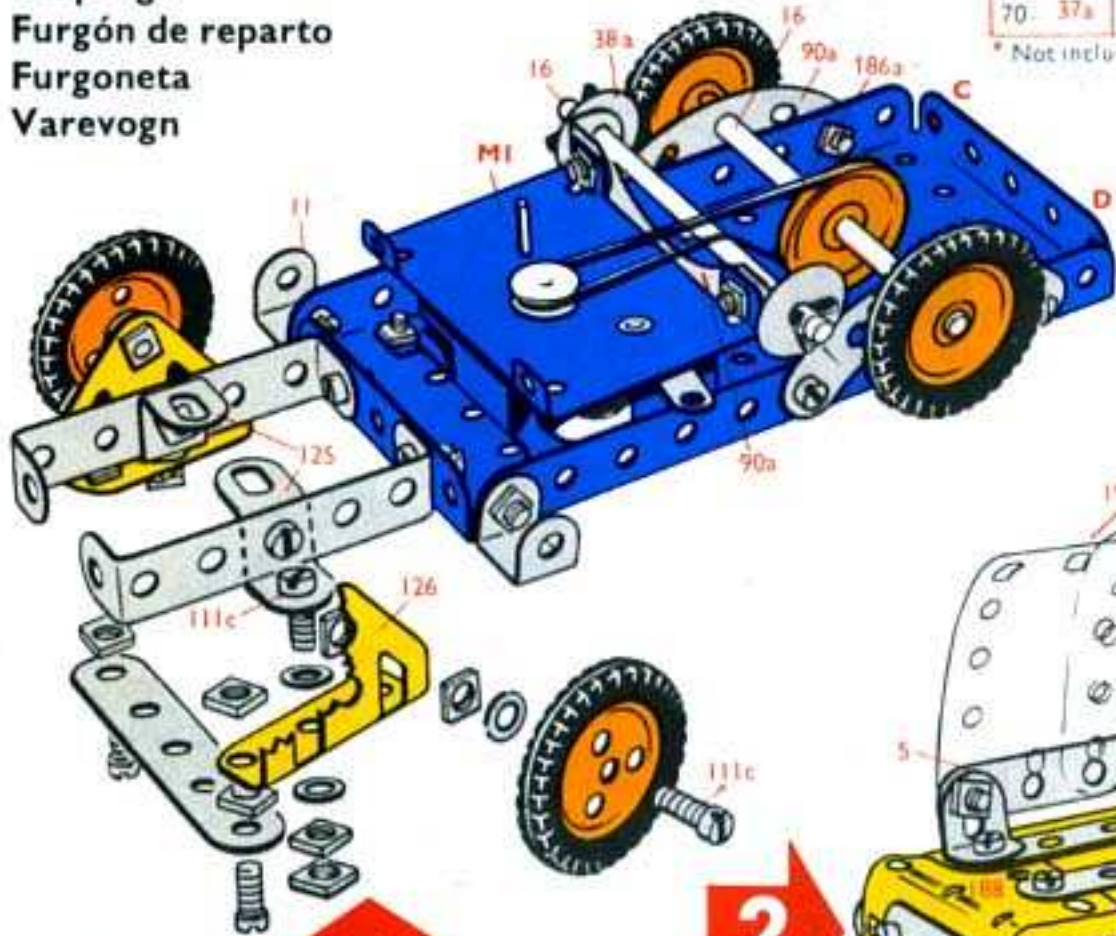

1	5	2	38d
2	11	2	48a
2	12	1	52
2	16	3	90a
3	22	4	111c
2	22a	2	125
2	35	2	126
24	37a	4	142c
16	37b	*1	186a
6	38		

8	5	15	37b
3	10	4	38
2	12	1	126a
1	18a	1	155
1	22	2	188
1	24	2	193
1	35	1	199
15	37a	2	221

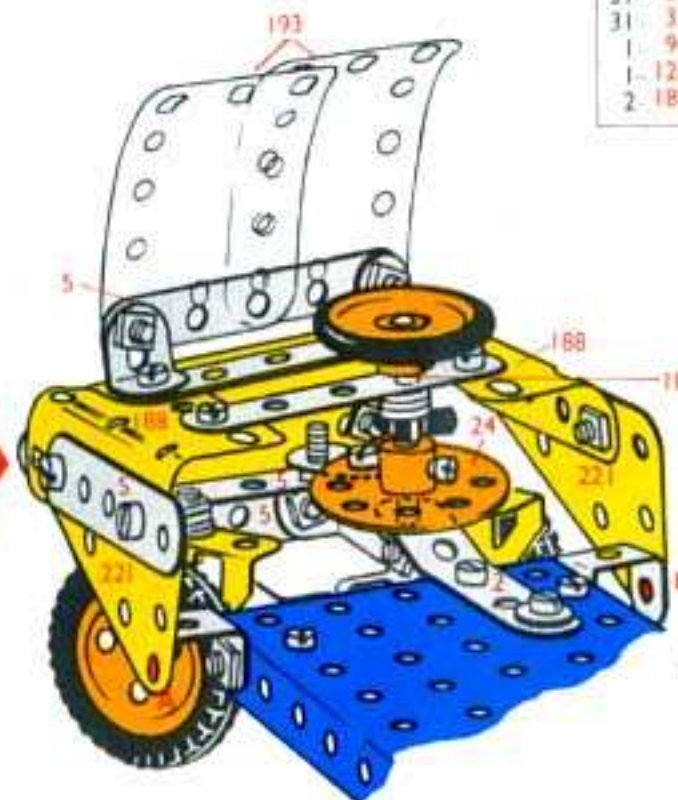

6	2	2	190
1	18b	2	191
31	37a	2	192
31	37b	2	194
1	90a	2	194a
1	126a	1	212
2	189	1	214

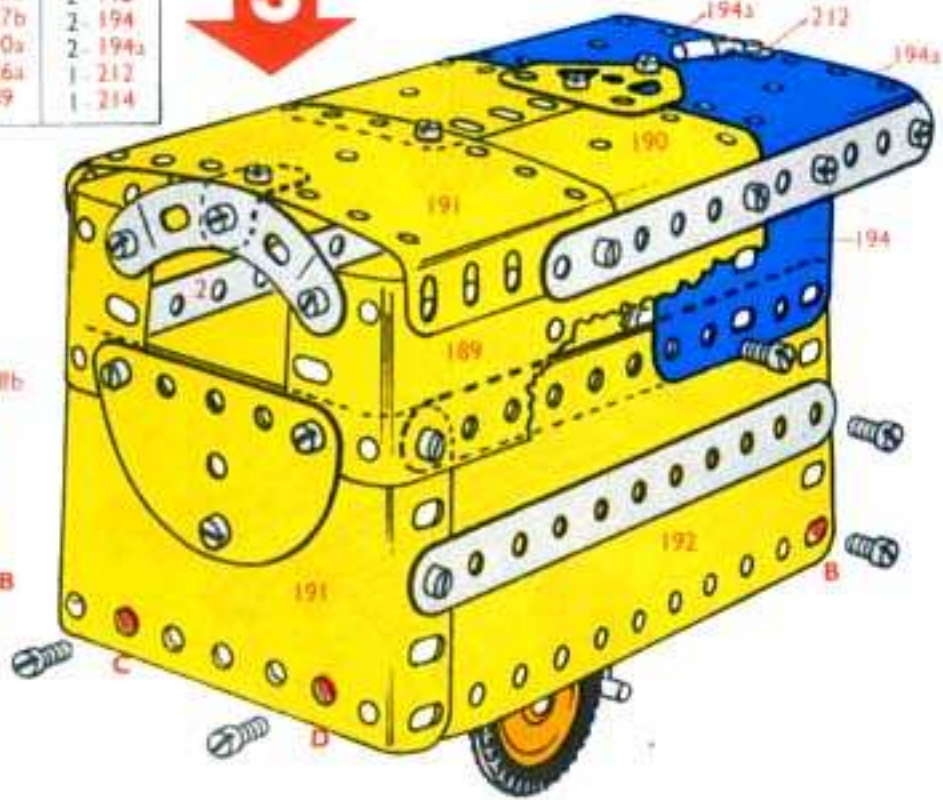
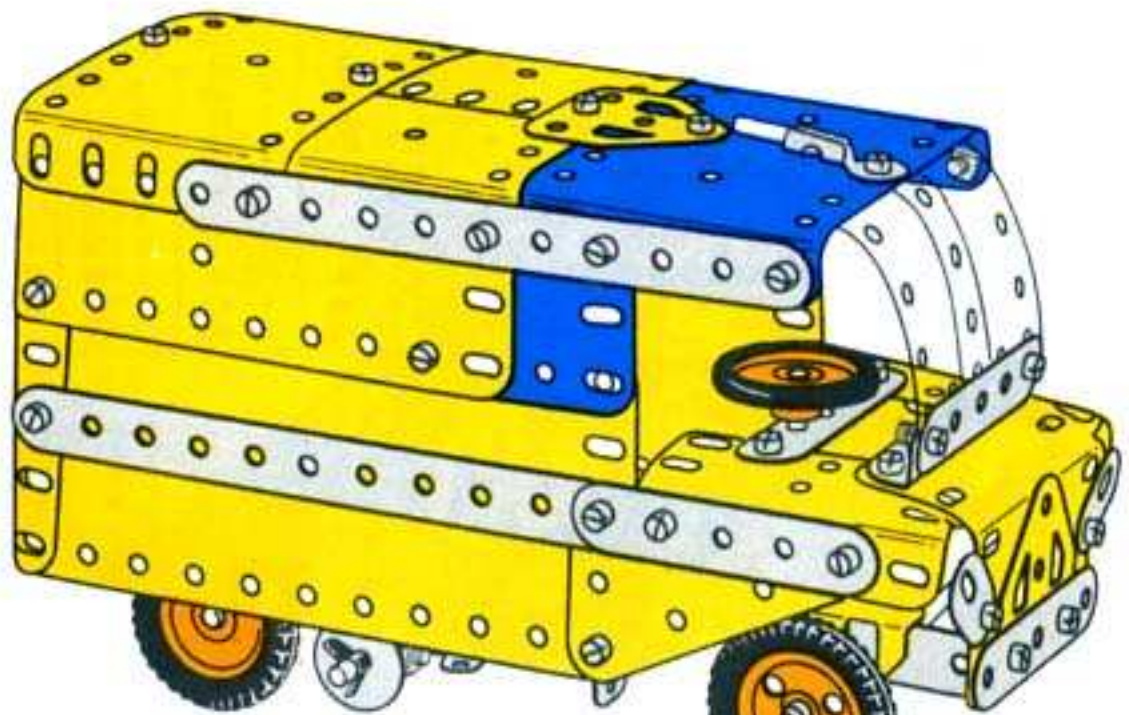

4.12.

Sewing Machine  
 Naaimachine  
 Machine à coudre  
 Macchina per cucire  
 Nähmaschine  
 Symaskin  
 Máquina de coser  
 Máquina de costura  
 Symaskin

5- 2	1- 24	1-142c
7- 5	5- 35	1-176
5-10	45-37a	2-188
2-11	38-37b	1-189
10-12	10-38	1-190
2-16	1-38d	2-192
2-17	2-48a	1-193
1-18a	1-52	2-194
1-18b	3-90a	1-199
1-19a	5-111c	1-212
1-20a	2-125	1-213
3-22	2-126	2-214
1-23	2-126a	4-221

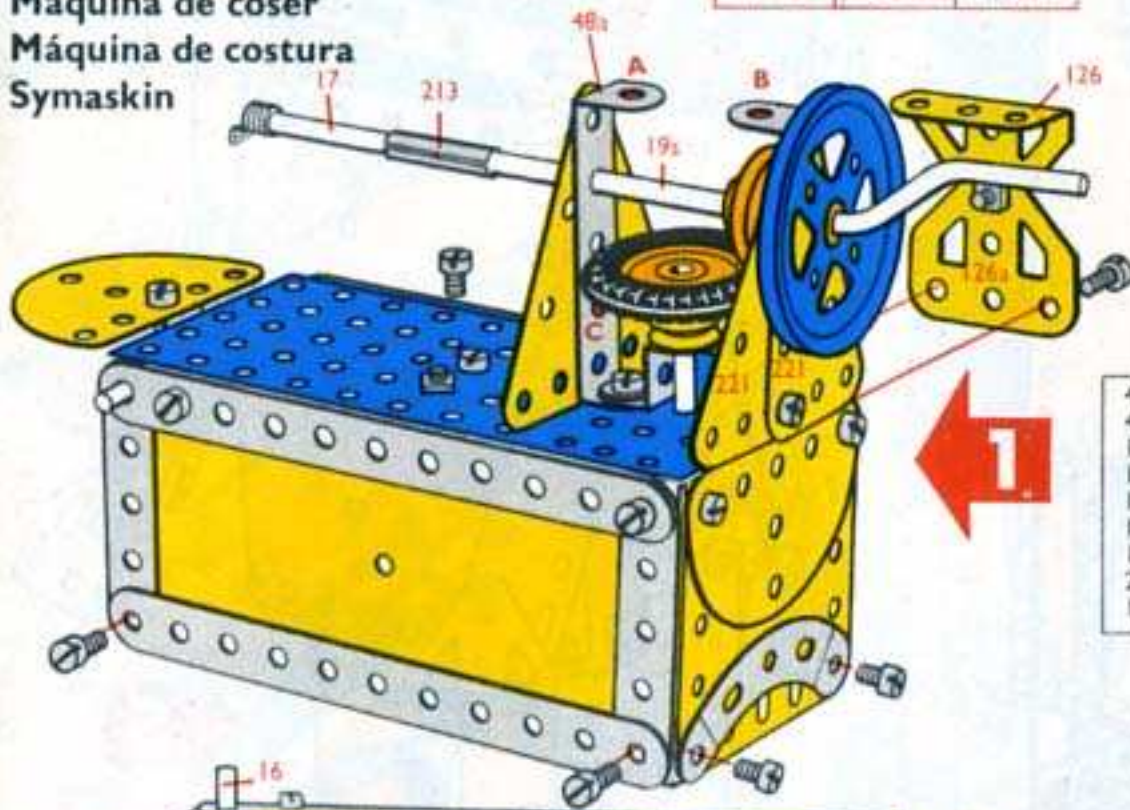

4- 2	19- 37a	1-176
4- 5	19- 37b	1-190
1-16	2-48a	2-192
1-17	1-52	1-193
1-18a	2-90a	1-213
1-19a	2-125	2-214
1-20a	1-126	4-221
2-22	1-126a	
1-23	1-142c	

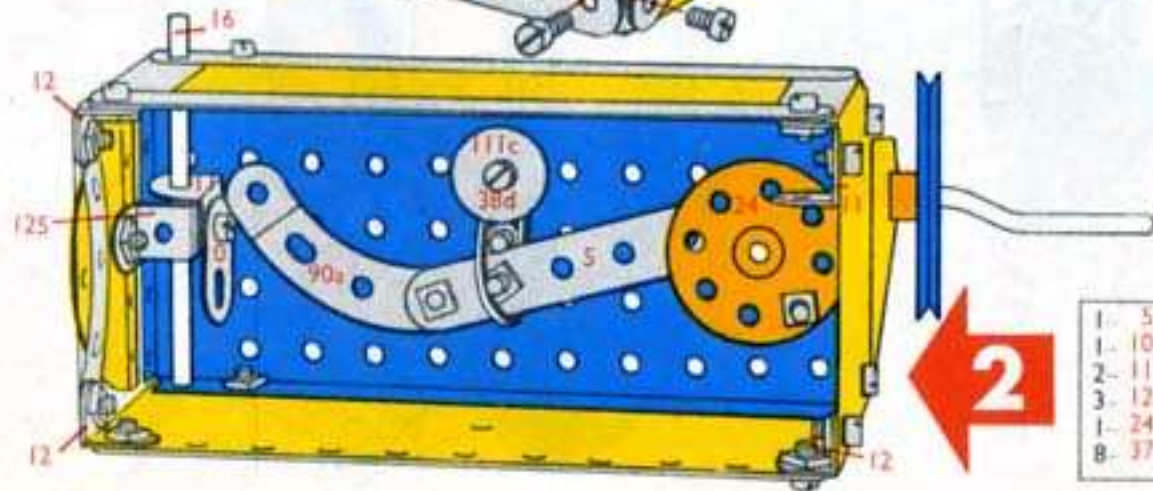

1- 5	2- 37b
1-10	2- 38
2-11	1-38d
3-12	1-90a
1-24	4-111c
8-37a	1-186

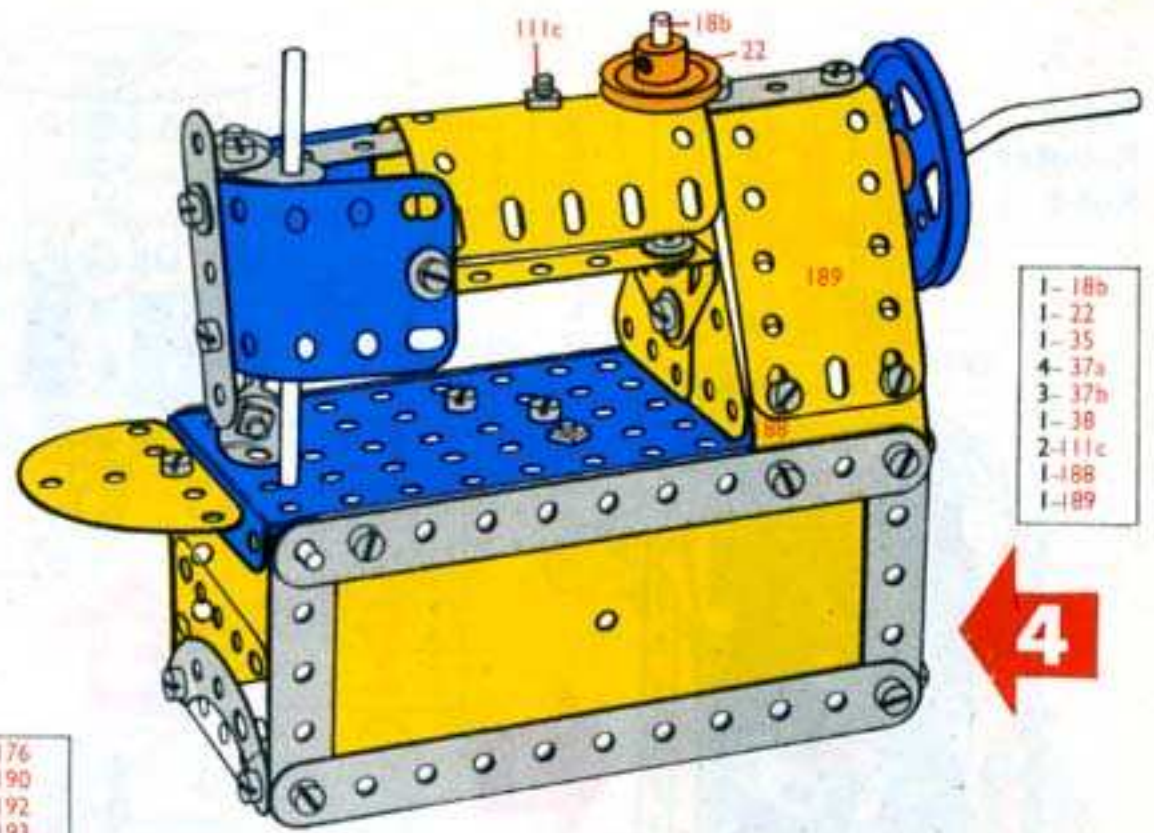

1-18b
1-22
1-35
4-37a
3-37b
1-38
2-111c
1-188
1-189

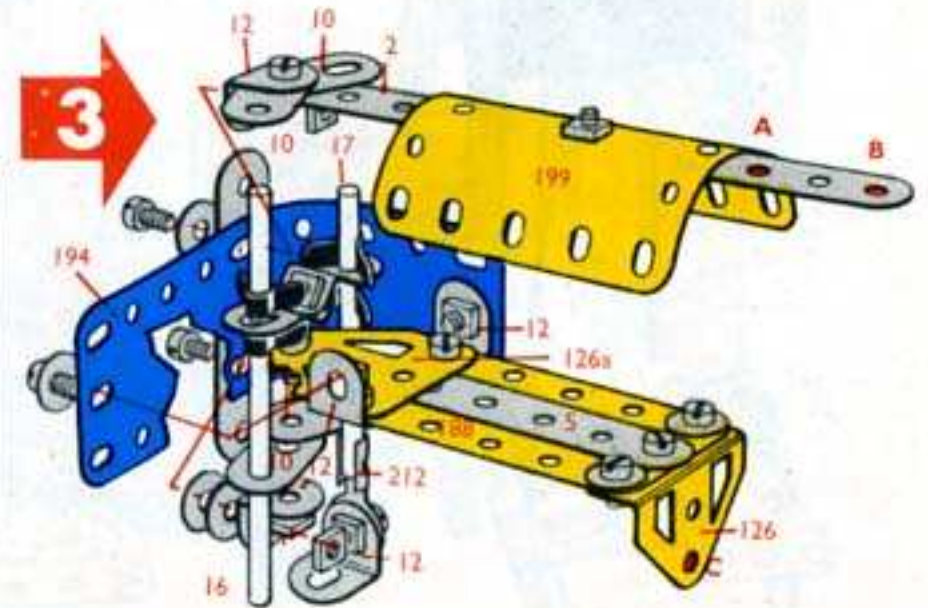

1- 2
2- 5
4-10
7-12
1-16
1-17
4-35
14-37a
14-37b
7-38
1-126
1-126a
1-188
2-194
1-199
1-212

# 4.13.

## Robot Roboter Robô

4- 2	1- 23	2-111c	2-194
9- 5	*1- 23a	1-125	1-199
5-10	2- 24	1-126	1-200
2-11	2- 27f	1-126a	1-213
5-12	61- 37a	1-186	2-214
1-15b	59- 37b	*1-186a	4-215
1-16	3- 38	*1-186b	4-221
2-17	2- 38d	2-188	*1-M1
1-18a	1- 40	2-189	
1-20a	2- 48a	2-190	
3-22	1- 52	2-191	
2-22a	4- 90a	2-192	

\*Not included in set

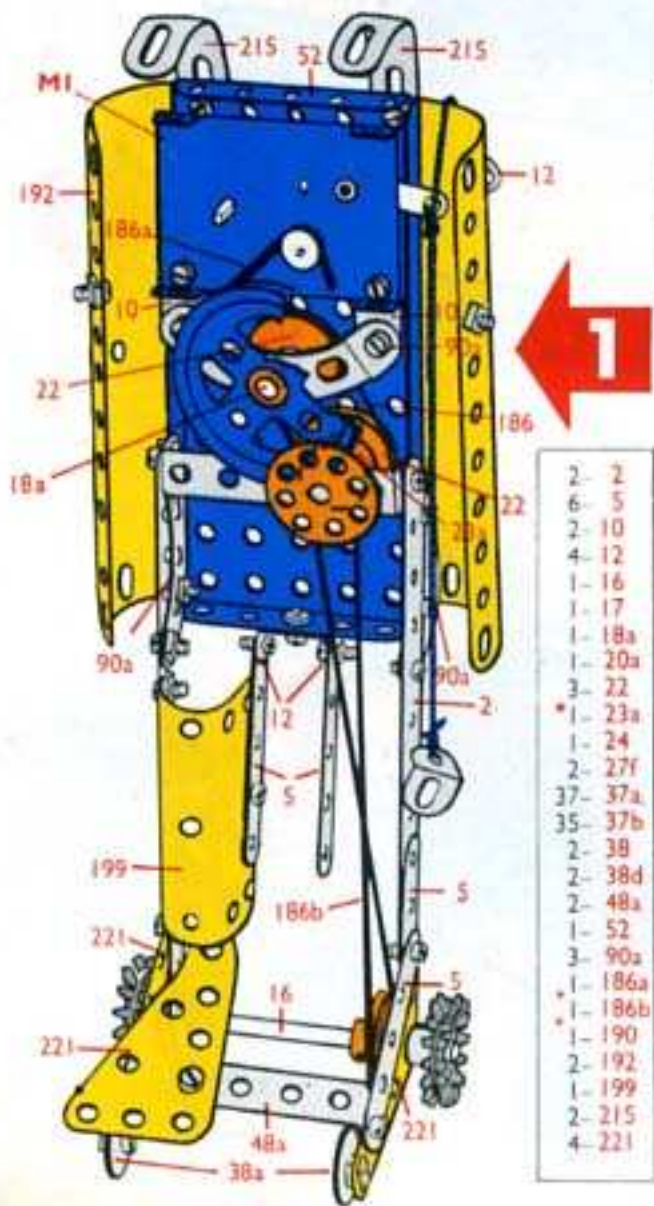

**1**

2- 2
6- 5
2-10
4-12
1-16
1-17
1-18a
1-20a
3-22
*1-23a
1-24
2-27f
37-37a
35-37b
2-38
2-38d
2-48a
1-52
3-90a
*1-186a
*1-186b
1-190
2-192
1-199
2-215
4-221

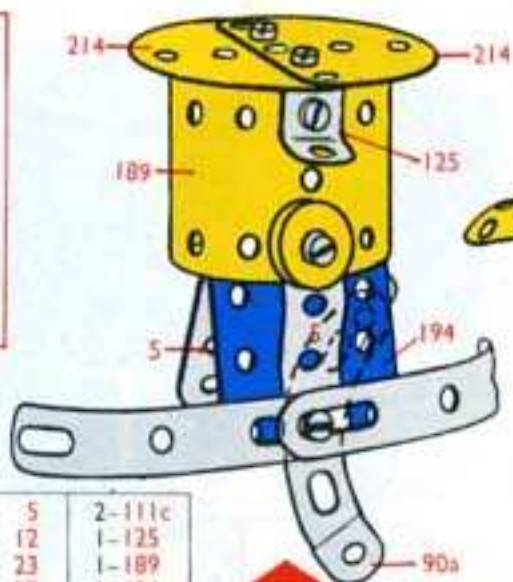

**3**

2- 5	2-111c
1-12	1-125
1-23	1-189
8-37a	1-194
8-37b	2-214
2-38	2-215
1-90a	

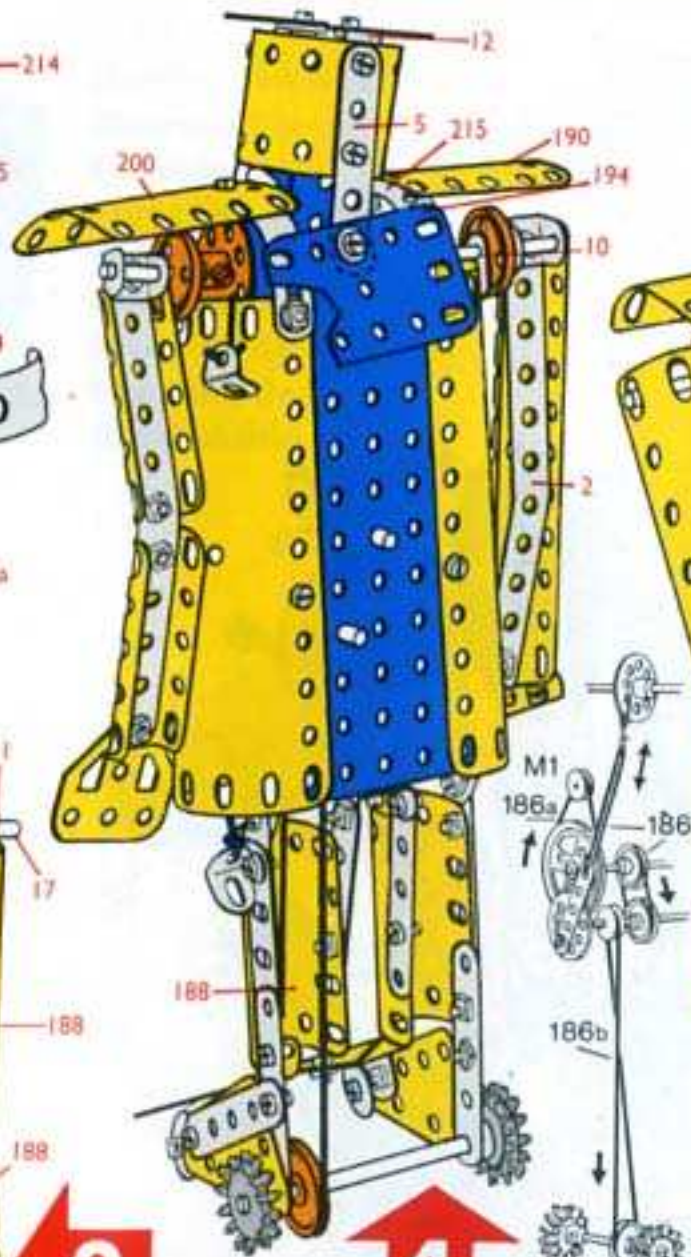

**4**

2- 2	6- 37b
1- 5	1- 40
2-10	1-126
2-11	1-126a
1-15b	1-186
1-17	2-188
2-22a	1-189
1-24	1-213
6-37a	

5- 37a
5- 37b
1- 38
1-190
1-194
1-200

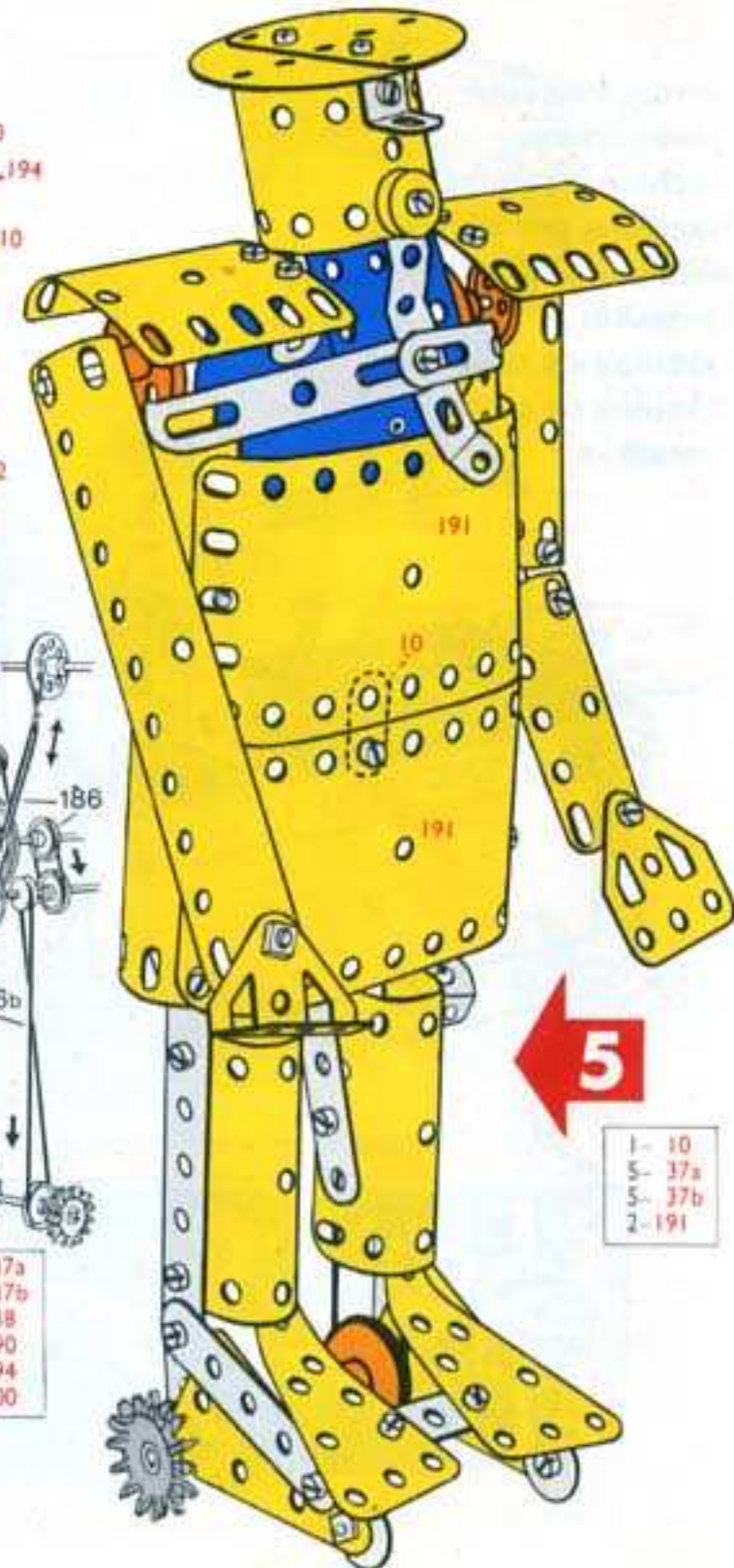

**5**

1- 10
5- 37a
5- 37b
2-191

### 4.14.

Meccanograph  
 Meccanograaf  
 Mécanographe  
 Meccanografo  
 "Meccanograph"  
 Mecanografo  
 Meccanograf

2-	1	32-	37b
3-	2	10-	38
4-	5	2-	48a
2-	10	1-	52
2-	11	6-	111c
6-	12	2-	125
1-	18a	2-	126
1-	20a	*1-	186a
2-	24	1-	214
39-	37a	*1-	M1

\* Not included in set

2-	10
1-	11
4-	12
1-	18a
1-	20a
1-	24
12-	37a
12-	37b
2-	38
1-	52
*1-	186a
1-	214

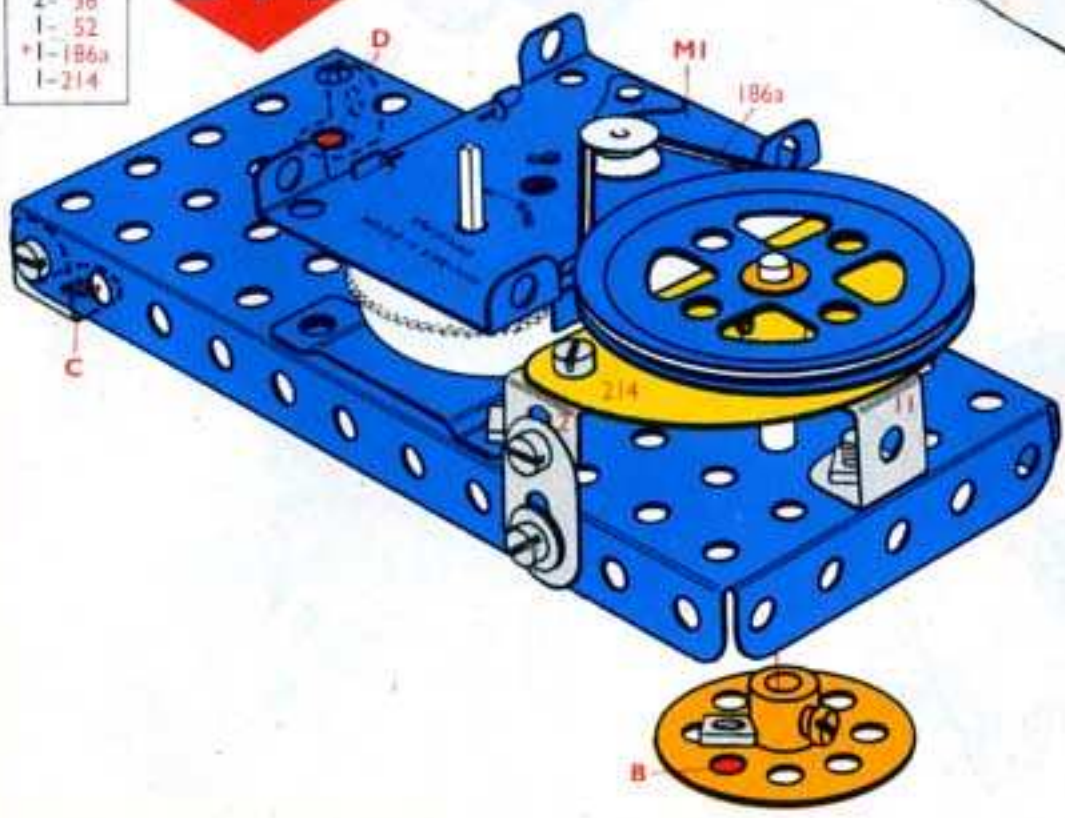

3-	2
2-	5
1-	11
19-	37a
11-	37b
2-	38
4-	111c
2-	125
2-	126

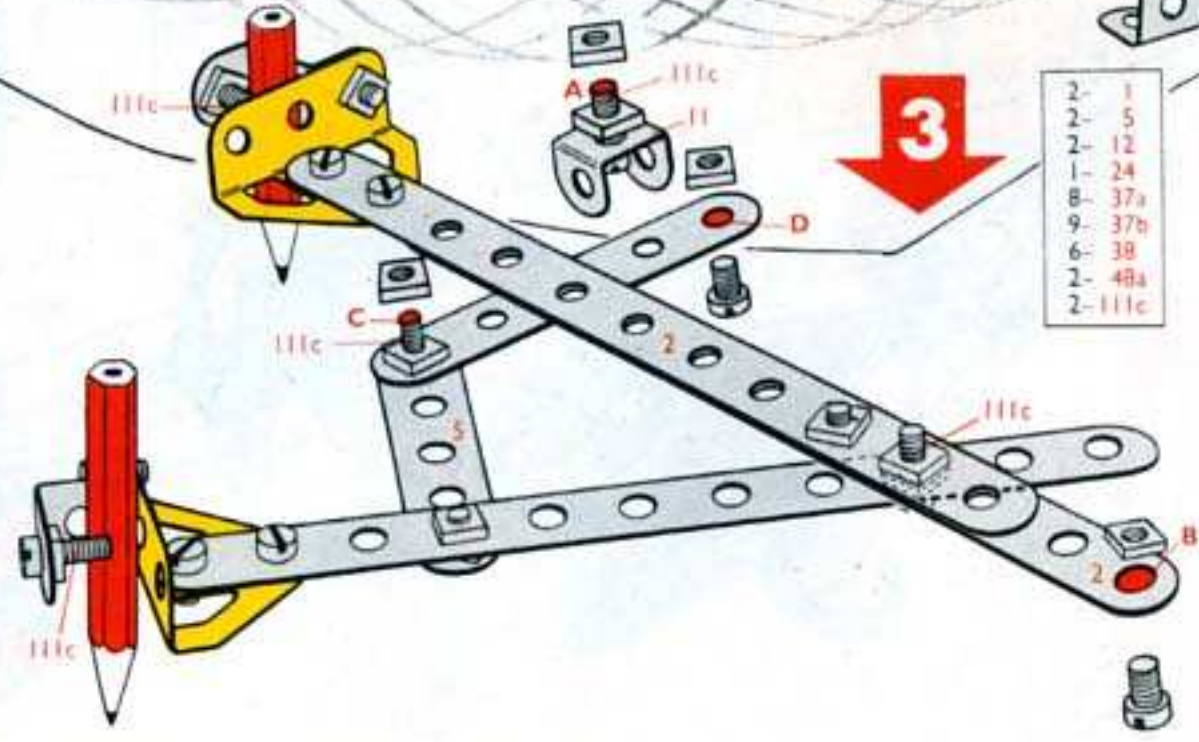
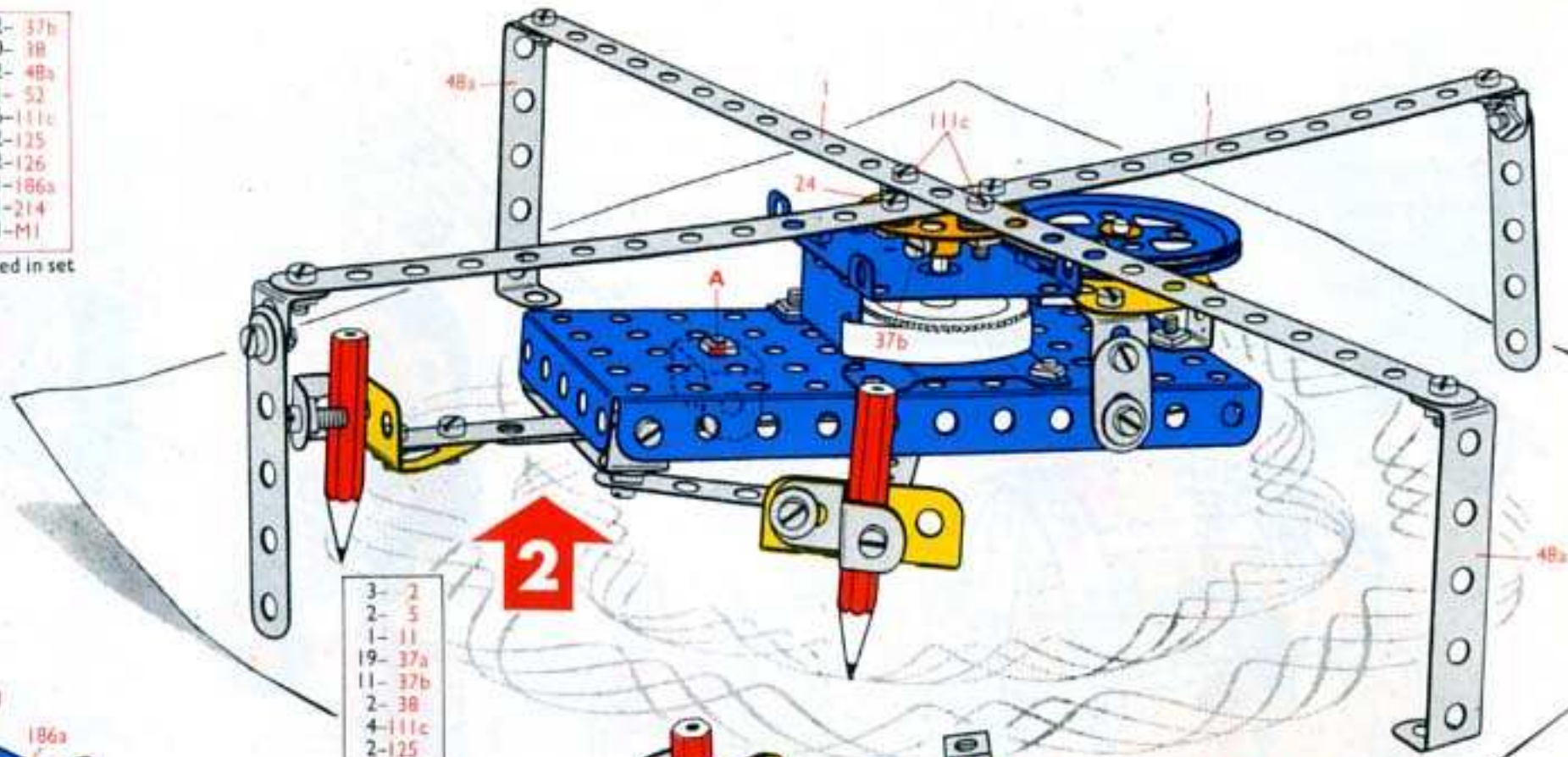

2-	1
2-	5
2-	12
1-	24
8-	37a
9-	37b
6-	38
2-	48a
2-	111c

**4.15.**  
**Lunar Vehicle**  
**Maanvoertuig**  
**Véhicule lunaire**  
**Veicolo lunare**  
**Mondfahrzeug**  
**Månfordon**  
**Vehículo lunar**  
**Veiculo lunar**  
**Månekjøretøy**

2- 1	2- 24	1-155
6- 2	5- 35	1-176
8- 5	72- 37a	*1-186a
1- 11	47- 37b	*1-186b
4- 12	6- 38	1-189
1- 15b	2- 48a	2-189
2- 16	1- 57c	2-193
2- 17	4- 90a	1-200
1- 20a	3-111c	1-212
4- 22	1-125	4-215
2- 22a	1-126	3-221
1- 23	1-126a	*1-M1
*1- 23a	4-142c	

\* Not included in set.

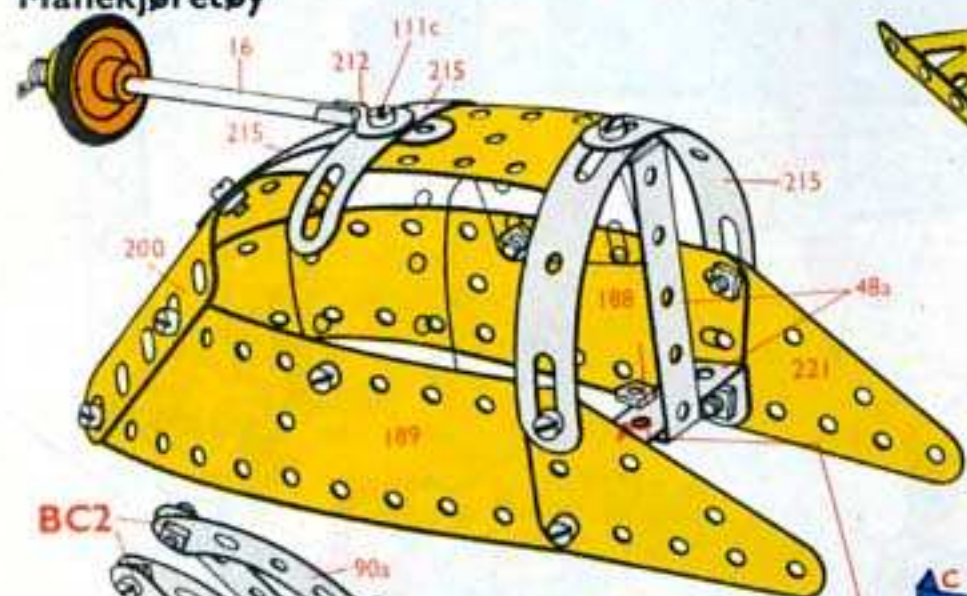

BC2

1

2- 1	1- 24
4- 2	5- 35
1- 11	24- 37a
3- 12	16- 37b
1- 15b	6- 38
1- 16	1- 57c
2- 17	2- 90a
1- 20a	2-111c
3- 22	4-142c
2- 22a	*1-186a
*1- 23a	*1-186b

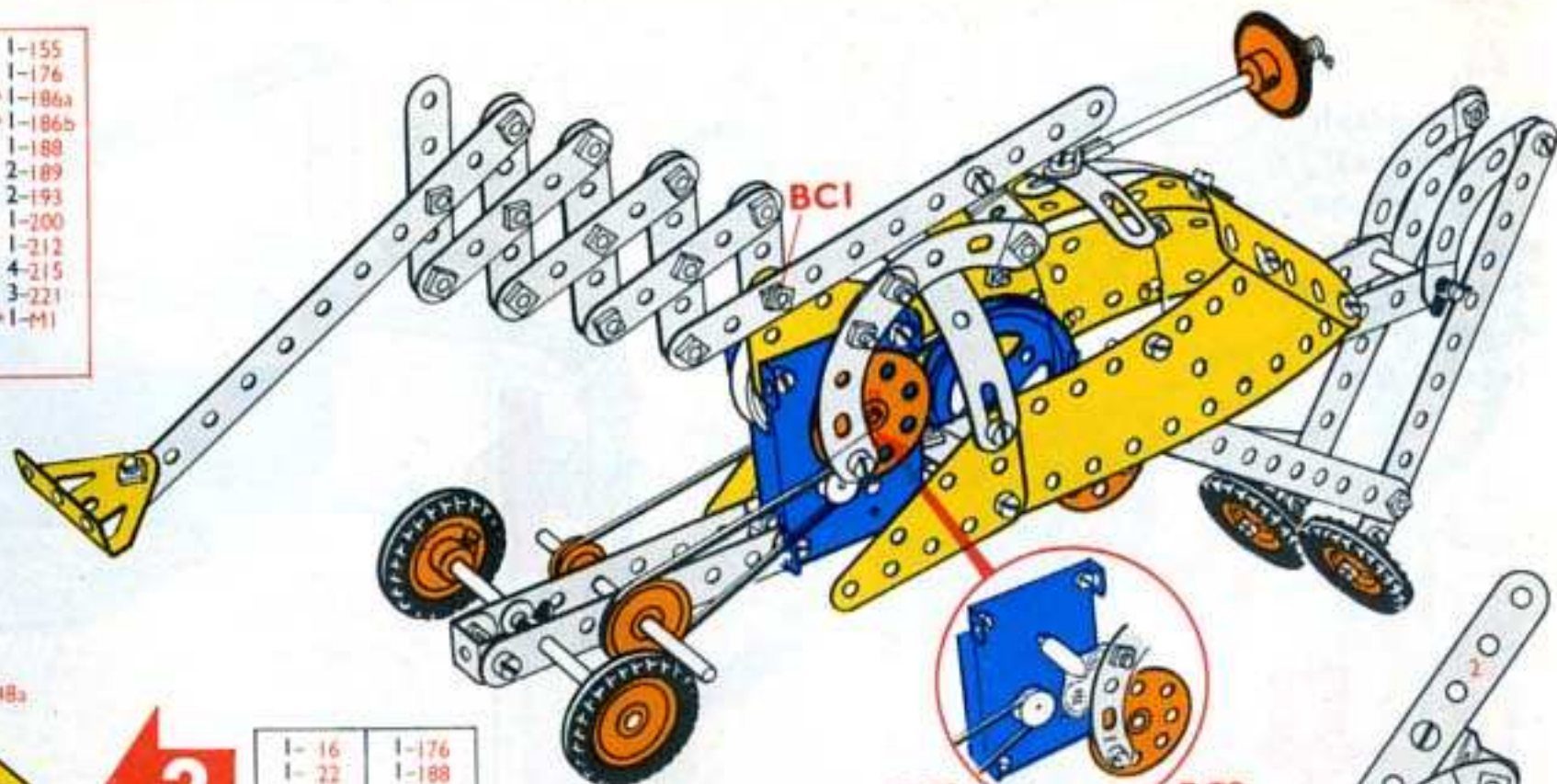

BC1

2

1- 16	1-176
1- 22	1-188
1- 23	2-189
13- 37a	2-193
12- 37b	1-200
2- 48a	1-212
1-111c	4-215
1-126a	2-221
1-155	

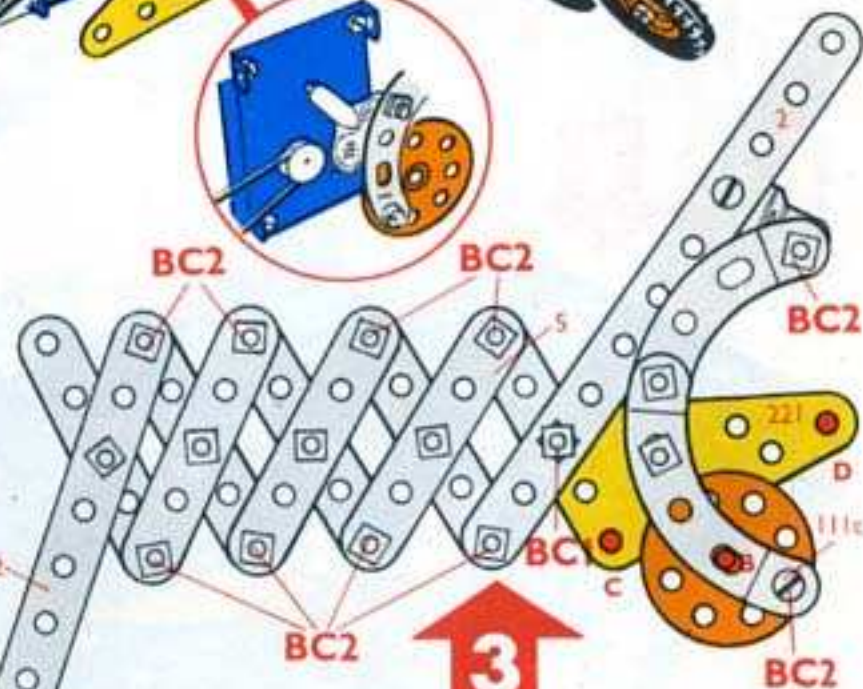

BC2

3

2- 2
8- 5
1- 12
1- 24
35- 37a
19- 37b
2- 90a
1-125
1-126
1-221



# ELECTRONIC 4.16

Frontier Barrier  
 Douane-tolhek  
 Barrière de douane  
 Barriera di frontiera  
 Grenzschanke  
 Granssparr  
 Barrera fronteriza  
 Barreira de fronteira  
 Grensebom

2- 1	2- 24	*1- 186a
6- 2	1- 35	2- 189
9- 5	56- 37a	2- 190
2- 10	55- 37b	2- 191
6- 12	5- 38	2- 192
2- 16	2- 48a	2- 214
1- 20a	1- 52	*1- M5
1- 23	1- 111c	
*1- 23a	2- 126	

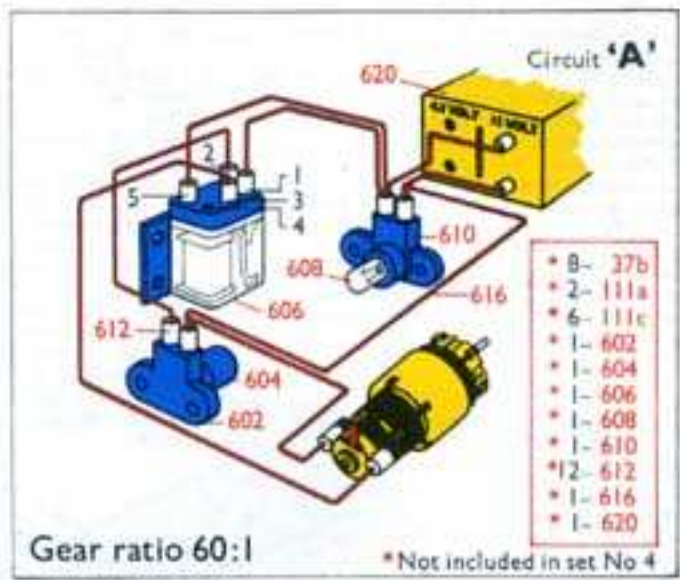

- \* 8- 37b
- \* 2- 111a
- \* 6- 111c
- \* 1- 602
- \* 1- 604
- \* 1- 606
- \* 1- 608
- \* 1- 610
- \* 12- 612
- \* 1- 616
- \* 1- 620

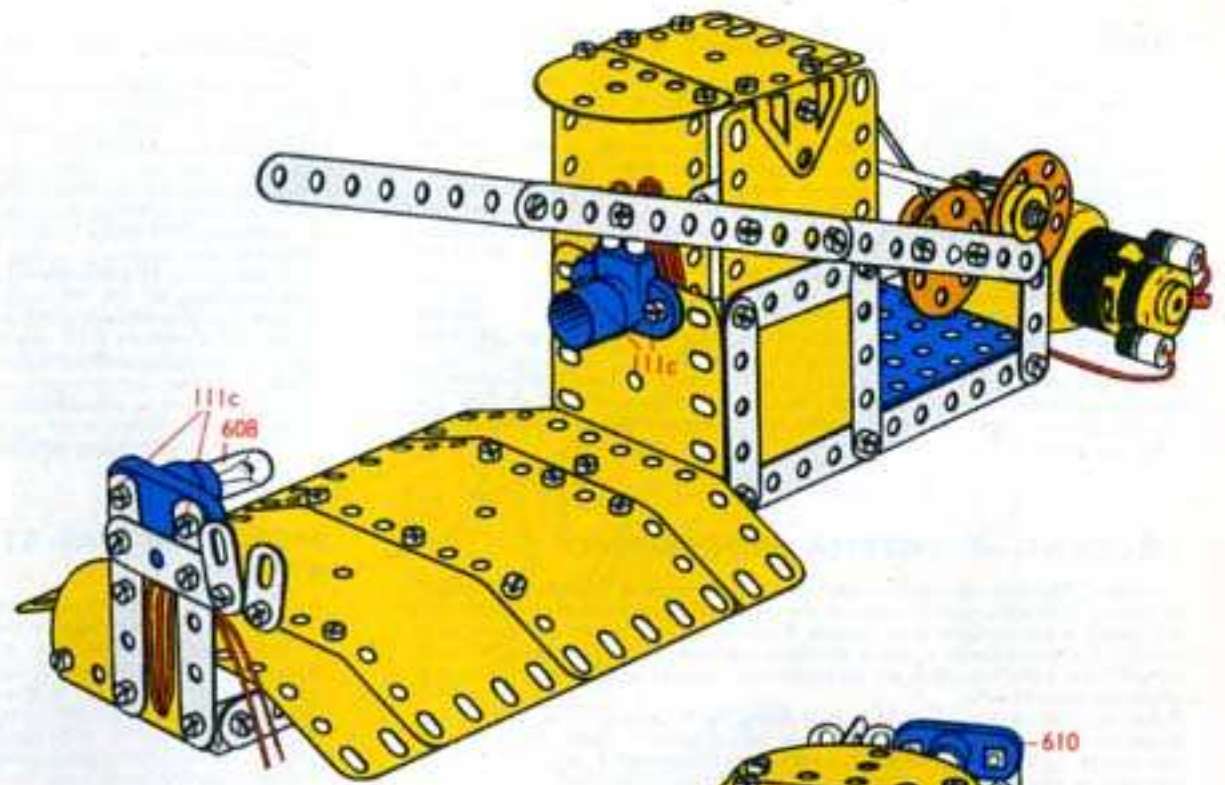

\*Not included in set 4

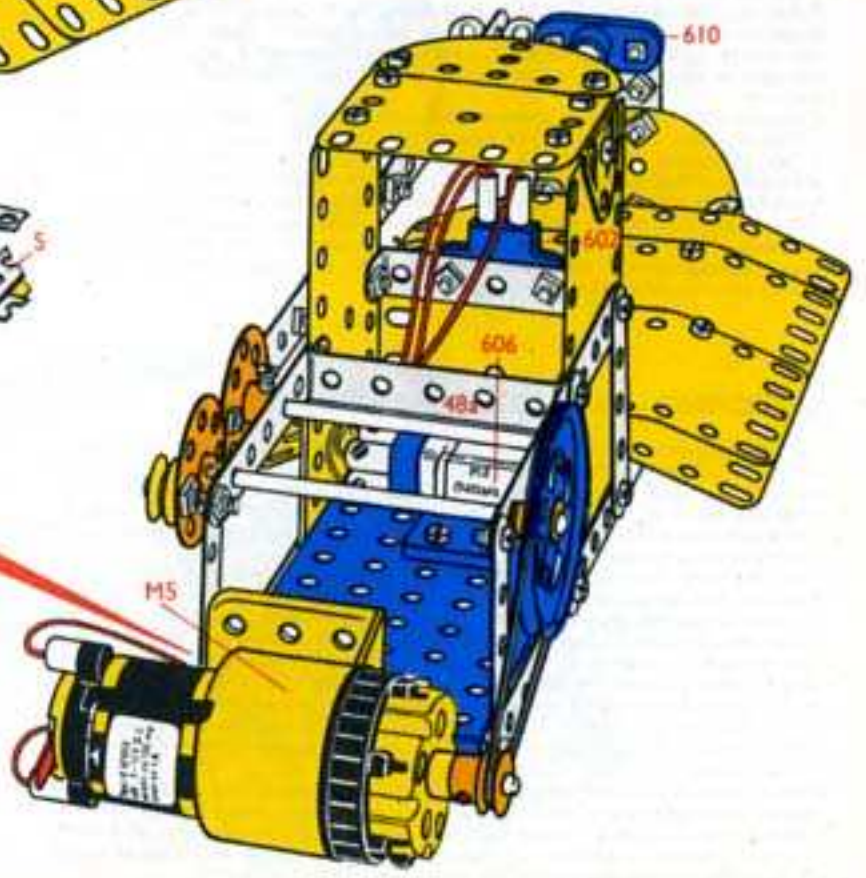
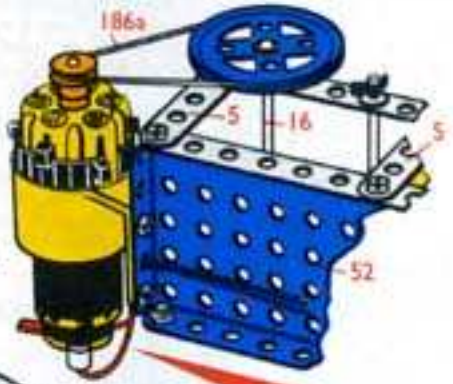
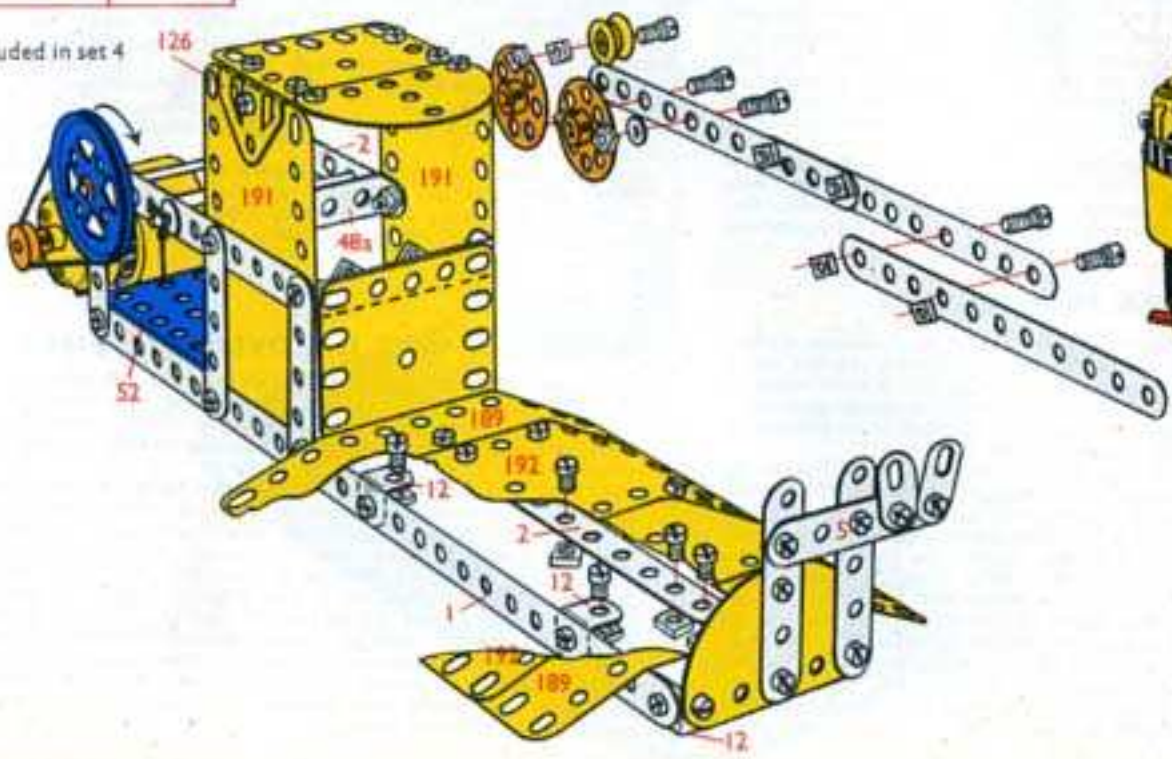

## MECCANO—THE PROGRESSIVE SYSTEM

The standard Meccano system consists of a range of Main Sets numbered from 1 to 10, which get progressively larger as the Set number increases. This means that Set 2 contains all the parts included in Set 1, plus a quantity of additional Parts, while Set 3 contains all the Parts in Set 2, plus a further quantity of additional Parts, and so on, right up to the No. 10 Set.

Also included in the standard system is a series of eight Conversion Sets. These are not intended as constructional sets in their own right, but simply contain the necessary extra Parts to convert a main Set into the next larger, e.g. Set 1 together with Conversion Set IX makes Set 2, and so on. Also available is a series of motorised Sets: 3M, 4M, and 5ME. These are equivalent to Main Sets 3, 4, and 5 with the addition of a Meccano Motor—the Reversible 4½ volt DC Motor in the 3M and 4M and the 3-12 volt DC Motor with 6-ratio Gearbox in the 5ME Set. The 5ME Set also includes the components contained in the Electronic Control Set.

Other current outfits are the Gears and Mechanisms Sets, both of which contain a selection of standard gears to further mechanise your models, and the 4EL Set equivalent to the standard No. 4 set with the addition of special electrical parts.

## MECCANO—IL SISTEMA PROGRESSIVO

Il Sistema Meccano standard è costituito da una serie di Scatole Base numerate da 1 a 10 che, con il crescere del numero, diventano progressivamente più grandi e più complete. La Scatola 2 contiene tutti i Pezzi compresi nella Scatola 1 più un certo numero di Pezzi addizionali; la Scatola 3 contiene tutti i Pezzi della Scatola 2 più un certo numero di Pezzi addizionali, e così via fino al Meccano 10.

Il Sistema Meccano comprende inoltre 8 Scatole di Conversione, le quali non possono essere utilizzate da sole, ma contengono i Pezzi necessari per convertire una Scatola Base in quella immediatamente più grande, per esempio la Scatola 1 più la Scatola di Conversione IX formano la Scatola 2 e così via.

L'assortimento Meccano comprende anche Scatole motorizzate 3M, 4M e 5ME, che sono equivalenti alle Scatole Base 3, 4 e 5 ciascuna con l'aggiunta di un Motorino Meccano: il Motorino Elettrico 4½ volts nelle Scatole 3M e 4M, e il Motorino Elettrico con Cambio a 6 Velocità nella Scatola 5ME. Nella Scatola 5ME sono incluse anche Parti Meccano della Serie Elettronica. Fanno parte del sistema Meccano anche le Scatole Ingranaggi e Meccanismi contenenti vari ingranaggi standard Meccano che servono per "meccanizzare" maggiormente i modelli e la Scatola 4-EL corrispondente alla Scatola 4 però con l'aggiunta di speciali pezzi elettrici.

## MECCANO—EL JUGUETE PROGRESIVO

El Meccano standard se compone de una serie de Juegos Básicos, numerados de 1 a 10, cuyo surtido de piezas aumenta progresivamente según el número de referencia del juego. Es decir, el Juego No. 2 contiene todas las piezas incluidas en el No. 1 más una serie de elementos adicionales; el Juego 3 tiene todas las piezas del No. 2 complementadas con varias más, y así sucesivamente hasta el Juego No. 10.

En el Meccano standard figura también una serie de Equipos de Conversión. Estos no son juegos de construcción propiamente dichos, sino que reúnen los complementos necesarios para convertir un Juego Básico determinado en el del número siguiente. Por ejemplo, el Juego No. 1 y el Equipo de Conversión IX forman el Juego 2, etc. etc. Se ofrece también una serie de juegos motorizados: 3M, 4M y 5ME, los cuales equivalen a los Juegos Básicos 3, 4 y 5 complementados con un Motor Meccano (Motor Meccano reversible de 4,5 V.c.c. en los Nos. 3M y 4M y Motor de 3-12V en el No. 5ME). El Juego 5ME contiene también las piezas comprendidas en el Equipo de Control Electrónico.

Entre otros equipos comprendidos en la serie actual se encuentran los juegos de engranajes y mecanismos, ambos de los cuales cuentan con una selección de ruedas dentadas standard para mecanizar aún más el funcionamiento de sus modelos, así como el Juego 4 EL que equivale al juego standard no. 4 complementado con piezas eléctricas especiales.

## MECCANO—HET PROGRESSIEVE SYSTEEM

Het standaard Meccano-systeem omvat een serie hoofd-sets, genummerd van 1 t/m 10, die progressief groter worden met het opklimmen van de nummers. Dit betekent dat set 2 alle onderdelen bevat van set 1, plus een aantal extra onderdelen, terwijl set 3 alle onderdelen van set 2 bevat, plus een aantal extra onderdelen, enz., tot set no. 10.

Tevens omvat het standaard systeem een serie uitbreidingssets, n.l. 8 stuks. Deze zijn niet bedoeld als op zichzelf staande constructiesets, maar bevatten de noodzakelijke extra onderdelen om een hoofdsat uit te breiden tot het volgende set-nummer, zodat bijvoorbeeld Set No. 1 tezamen met de uitbreidingsset IX gelijk wordt aan Set No. 2, enz. Ook zijn gemotoriseerde sets leverbaar, n.l. 3M, 4M, en 5ME. Deze zijn gelijkwaardig aan de hoofdsats 3, 4 en 5 met toevoeging van een Meccano motor—Meccano 4½ volt Motor in sets 3M en 4M de 3-12 volt Motor in 5ME. Set 5ME bevat ook de onderdelen uit de elektronische Schakelkast.

Andere nieuwe uitrustingen omvatten tandwiel- en gemechaniseerde sets, die beide een serie standard tandwielen bevatten om de modellen verder te mechaniseren. Tevens is de set 4 EL leverbaar, die gelijk is aan de standaard set no. 4, met bijvoeging van speciale elektrische onderdelen.

## MECCANO—DAS STUFENWEISE AUSBAUBARE SYSTEM

Das Meccano-Standardsystem besteht aus einer Reihe von Hauptkästen, die mit den Zahlen 1 bis 10 bezeichnet sind; diese Bausätze werden umfassender, je höher die Kennziffer ist, d.h. dass Bausatz 2 nicht nur alle Teile von Kasten 1 enthält, sondern ausserdem eine Reihe von Zusatzteilen. Das gleiche gilt für Satz 3; er verfügt über alle Teile aus Satz 2 und daneben über zahlreiche Zusatzteile. Das geht so weiter bis Satz 10.

Zum Standardssystem gehören weiterhin eine Reihe von acht Ergänzungskästen. Sie sind nicht als eigenständige Bausätze gedacht, sondern umfassen lediglich die notwendigen Zusatzteile, um einen Hauptkasten so zu vervollständigen, dass er der nächst höheren Stufe entspricht; das bedeutet z.B., dass Satz 1 plus Ergänzungskasten IX über die gleiche Anzahl von Teilen verfügt, wie sie in Satz 2 vorliegen usw. Weiterhin sind Bausätze mit Motor erhältlich: 3M, 4M und 5ME. Sie entsprechen den Kästen 3, 4 und 5 und enthalten ausserdem einen Meccano-Antriebsmotor; bei Satz 3M und 4M handelt es sich dabei um den 4½ Volt Meccano-Gleichstrom-wendomotor, bei 5ME um den 3-12 Volt Meccano-Gleichstrom-Motor mit 6-Gang-Getriebe. Der Kasten 5ME umfasst weiterhin die Einzelteile aus dem Elektronikbauteilekasten.

Weitere erhältliche Kästen umfassen Sätze mit Zahnrädern, Getrieben und anderen Teilen, die eine Reihe von Standardbauteilen enthalten, mit deren Hilfe die gebauten Modelle noch weiter mechanisiert werden können. Der Satz 4 EL umfasst neben den Standardbauteilen des Kastens Nr. 4 zusätzliche Elektrobauteile.

## MECCANO—O SISTEMA PROGRESSIVO

O sistema normal Meccano consiste numa linha de Jogos Principais numerados de 1 a 10, que se tornam progressivamente maiores à medida que o número do jogo aumenta. Isto significa que o Jogo No. 2 tem todas as peças incluídas no Jogo No. 1, mais um certo número de peças adicionais; o Jogo No. 3 contém todas as peças do Jogo No. 2 mais um certo número de peças adicionais e assim por diante, até ao Jogo No. 10.

Incluída no sistema normal está uma série de oito Jogos de Conversão. Estes jogos por si só não são jogos de construção, mas contêm simplesmente o número de peças extras necessárias a converter um Jogo Principal no jogo que se lhe segue, isto é o Jogo No. 1 juntamente com o Jogo de Conversão IX completa o Jogo No. 2, e assim por diante. Também se encontra à venda uma série de Jogos com motores: 3M, 4M e 5ME. Estes são equivalentes aos Jogos Principais Nos. 3, 4 e 5 mais com um motor Meccano—de 4½ voltios nos Jogos 3M e 4M e um motor Meccano de 12 voltios no Jogo 5ME. O Jogo 5ME também inclui os componentes do conjunto de Controlê Electrónico.

Outros equipamentos de fabrica corrente são os conjuntos de Engrenagens e Mecanismos os quais têm uma seleção de engrenagens normais para tornar os modelos ainda mais mecanizados, e o Jogo 4 EL, equivalente ao jogo normal No. 4 tem ainda peças eléctricas especiais.

## MECCANO—LE SYSTEME PROGRESSIF

Le système Meccano consiste en une série de boîtes principales, numérotées de 1 à 10, et dont l'importance augmente avec le numéro de série. Cela signifie que la boîte No. 2 contient toutes les pièces de la boîte No. 1, plus un certain nombre de pièces supplémentaires. Il en est de même pour la boîte No. 3 qui contient toutes les pièces du No. 2 auxquelles s'ajoutent un certain nombre de pièces supplémentaires, et ainsi de suite jusqu'au 10.

Une série de huit boîtes complémentaires fait également partie de ce système. Cependant, ce ne sont pas des boîtes de construction car elles ne contiennent que les pièces supplémentaires nécessaires à la conversion d'une boîte donnée en celle du numéro suivant; par exemple, la boîte complémentaire 2X transforme une boîte 2 en boîte 3, et ainsi de suite. Il existe également une série de boîtes motorisées: 3M, 4M et 5ME. Celles-ci correspondent très exactement aux boîtes 3, 4 et 5, avec l'addition d'un Moteur Meccano réversible 4,5 volts c.c. pour les boîtes 3M et 4M et le Moteur Meccano 3-12 volts c.c. avec boîte de vitesses rapport 6 dans la boîte 5ME. La boîte 5ME comprend également les éléments contenus dans la boîte électronique.

Les autres accessoires courants comprennent des jeux de mécanismes et d'engrenages qui contiennent tous deux une sélection d'engrenages standard permettant la mécanisation de vos modèles, et le jeu 4 EL, équivalent du jeu standard No. 4 avec des éléments électriques spéciaux supplémentaires.

## MECCANO—DET UTBYGGBARA SYSTEMET

Meccano standardsystem består av en serie huvudbyggsatser från 1 till 10, vilka ökar i storlek med numret. Detta innebär, att sats 2 innehåller alla delarna i sats 1 plus ett antal extra delar och att sats 3 innehåller alla delarna i sats 2 plus ytterligare ett antal extra delar o.s.v. ända upp till sats 10.

I standardsystemet ingår också en serie på åtta tilläggsatser. Dessa är inte avsedda att vara byggsatser i sin egen rätt utan innehåller helt enkelt de erforderliga extra delar, som behövs för att förvandla en huvudbyggsats till närmaste större sats. Sats 1 i förening med tilläggsats IX till exempel resulterar i sats 2 o.s.v. Dessutom finns det en serie motorsatser: 3M, 4M och 5ME. De motsvarar huvudbyggsatserna 3, 4 och 5 med tillägg av en motor—Meccano omkastbara 4,5 volts likströmsmotor i satserna 3M och 4M samt det Meccano 3-12 volts likströmsmotor med 6-växlad växellåda i sats 5ME. Sats 5ME innehåller också delar, vilka ingår i elektronisk manöversats.

Annan nuvarande utrustning utgörs av kugghjul och mekanismer, och båda dessa slags uppsättningar innehåller ett urval standarddrev för ytterligare mekanisering av modellerna. Uppsättning 4 EL motsvarar standard-upsättning 4, med tillägg av speciella elektriska detaljer.

## MECCANO—DET GRADVISE SYSTEMET

Meccanos standardsystem består av en rekke hovedsett som er nummererte fra 1 til 10 og som blir gradvis større i takt med nummereringen. Dette vil si at Sett 2 inneholder alle delene i Sett 1, pluss noen tilleggsdeler, mens Sett 3 inneholder alle delene i Sett 2, pluss ytterligere deler. Og så videre, like til Sett nr. 10.

Inkludert i standardsystemet er også en serie på åtte omdanningssett. Disse er ikke ment som byggesett i seg selv, men inneholder bare ganske enkelt de nødvendige ekstra deler som skal til for å omdanne et hovedsett til neste størrelse. F.eks. i Sett 1 sammen med omdanningssett IX utgjør Sett 2 osv. I tillegg til dette er der en serie motorsett: 3M, 4M og 5ME. Disse tilsvarer hovedsettene 3, 4 og 5 med tillegg av en Meccano 4½ volts Motor i sett nr. 3M og 4M, og en 3-12 volts Motor i sett nr. 5ME. Sett 5ME inneholder også de delene som inngår i Elektronisk Kontrollsettet.

Andre sett som kan fåes er gir- og mekanisme-settene; begge disse inneholder et utvalg av standard gir slik at modellene kan mekaniseres ytterligere, og 4 EL settet som tilsvarer standard sett nr. 4, men med tillegg av spesielle elektriske deler.

### SOME OF THE EXCITING MODELS BUILT WITH LARGER MECCANO SETS

ENIGE VAN DE SPECIALE MODELLEN DIE GEBOUWD KUNNEN WORDEN MET DE GROTERE MECCANO SETS  
 QUELQUES MODÈLES SENSATIONNELS RÉALISÉS AVEC LES GRANDS COFFRETS MECCANO  
 ALCUNI ENTUSIASMANTI MODELLI COSTRUITI CON I CORREDI MECCANO FORMATO GRANDE  
 EINIGE DER PHANTASTISCHEN MODELLE, DIE MIT DEN GRÖßEREN MECCANO SETS GEBAUT WERDEN KÖNNEN  
 NÅGRA AV DE SPÄNNANDE MODELLER SOM KAN BYGGAS MED STÖRRE MECCANOSATSER  
 ALGUNOS INTERESANTES MODELOS REALIZABLES CON LOS SUPER JUEGOS DE MECCANO  
 EIS ALGUNS DOS INTERESSANTES MODELOS QUE SE PODEM CONSTRUIR COM OS JOGOS MECCANO MAIORES  
 EN DEL AV DE SPENNENDE MODELLENE SOM ER BYGGET AV DE STÖRRE MECCANOSETTENE



This **Fork Lift Truck** is one of the attractive models that can be built with Set No. 7.

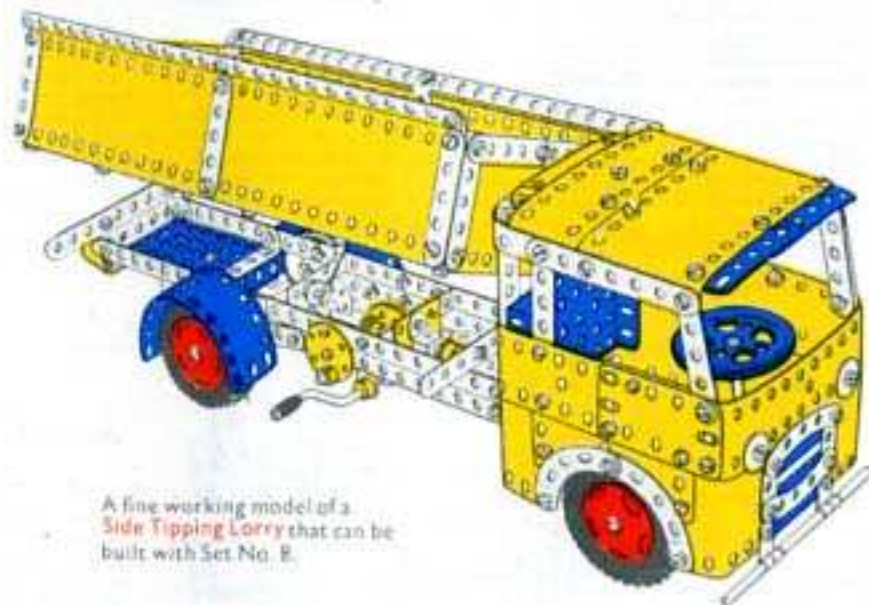

A fine working model of a **Side Tipping Lorry** that can be built with Set No. 8.

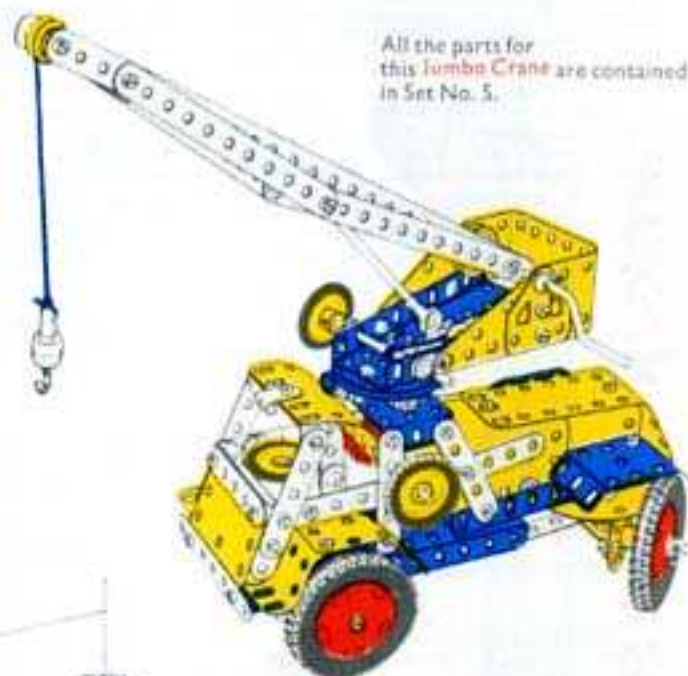

All the parts for this **Jumbo Crane** are contained in Set No. 5.

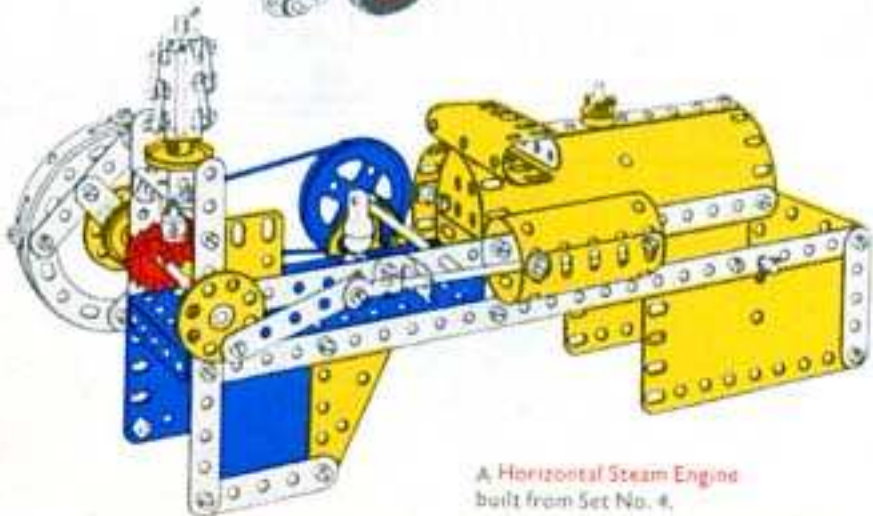

A **Horizontal Steam Engine** built from Set No. 4.

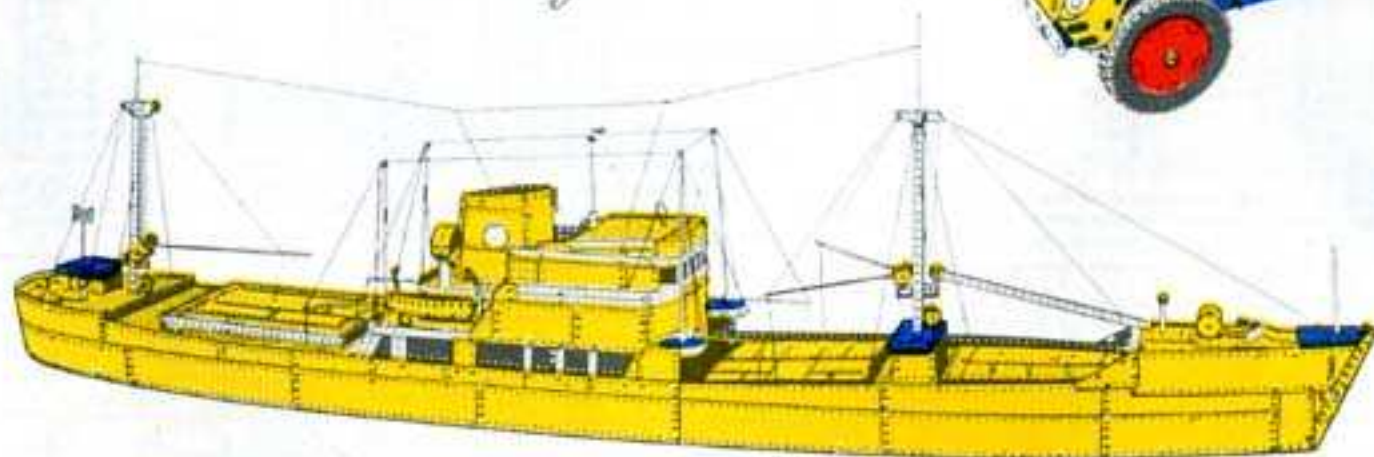

This striking model built with Set No. 10, reproduces the main external features of a typical high-capacity **Cargo Vessel**.

It has a raked stem, streamlined funnel and three cargo holds. The ship is over 7 ft. in length and has a beam of 13 in. approximately.

CONTENTS OF MECCANO SETS

Table with columns: SET, 1, 1a, 2, 3a, 3, 4, 4a, 5, No, DESCRIPTION, No, 5a, 6, 6a, 7, 7a, 8, 8a, 9, 10, Gears, Mechanisms. Rows include parts like Perforated Strip, Angle Girders, Pulleys, Gears, and various connectors.



## Electronics

### Electronic Accessory Set-

For remote control of Meccano Electric Motors. Contains a sensitive Photo-electric Cell with removable Hood, electrical relay, lamp and holder, 12 miniature plugs, coil of connecting wire and additional Nuts and Bolts. Also contains a Cylindrical Coil with removable ferrite core doubling as a solenoid, and a remote Control Battery Box. Complete with full instructions.

Batteries not included. Meccano Electric Motors may be operated remotely from the Battery Box which accommodates 9 'Ever Ready' (Berec) HP11 or equivalent batteries and gives separate reversible circuits of 12 volts (nominal) and 4½ volts d.c. The Battery Box is available separately.

### Elektronische accessoireset-

Voor AFSTANDSBEDIENING van elektrische Meccano motoren.

Bevat een gevoelige foto-elektrische cel met afneembare lichtkap, een elektrisch relais, lamp met houder, 12 miniaturstekers, een rol aansluitdraad, moeren en bouten, alsmede een solenoïde met uitneembare kern, die ook als elektromagneet kan dienen, en een batterijhuis voor afstandbediening. Het geheel gaat vergezeld van uitvoerige instructies. Batterijen zijn niet in de set aanwezig.

De elektrische Meccano motoren kunnen op afstand worden bediend door middel van het batterijhuis, dat plaats biedt aan 9 staafbatterijen van 1½ volt. Hiermede kan tegelijkertijd 12 en 4½ volt gelijkstroom worden afgegeven; voor beide is ook omkering van de stroomrichting mogelijk.

### Boîte de complément électronique-

Pour commande à distance des moteurs électriques Meccano.

Cellule photo-électrique avec capuchon amovible; relais électrique, ampoule et douille, 12 fiches miniature, bobine de fil électrique et écrous et boulons de rechange. Contient également une bobine cylindrique avec noyau amovible pouvant servir de solénoïde, et un boîtier à piles. Livré avec instructions détaillées.

Filles non incluses. Les moteurs électriques Meccano peuvent fonctionner à distance sur boîtier à 9 piles 'Ever Ready' (Berec) HP11 (ou similaires) donnant à volonté 12 volts et 4,5 volts, continu. Le boîtier à piles est disponible séparément.

### Serie Accessoria Elettronica-

Per il comando a distanza dei Motorini Elettrici Meccano.

Contiene una cellula fotoelettrica ad alta sensibilità con schermo luce amovibile, relais elettrico, lampadina e portalampada, 12 spine a banana, una matassina di filo per collegamenti, viti e dadi. E' inclusa nella serie una Bobina Cilindrica con nucleo di ferro amovibile che può anche servire come solenoide e infine una Scatola Portapile. Istruzioni complete e dettagliate.

Le pile non sono incluse. I Motorini Elettrici Meccano possono essere fatti funzionare a distanza per mezzo della Scatola Portapile che può contenere 9 pile adatte e fornisce circuiti separati invertibili a 12 volts (nominali) e 4½ volts corrente continua. La Scatola Portapile si fornisce separatamente.

### Set mit elektronischem Zubehör-

Zur Fernsteuerung von Meccano Elektromotoren. Enthält eine empfindliche Fotozelle mit abnehmbarer Lichtabschirmung, Relais, Lampe und Halter-

ung, 12 Miniatursteckern, eine Spule, Verbindungs-kabel und zusätzliche Schrauben und Muttern. Ebenfalls enthalten sind eine Zylinderspule mit herausnehmbarem Kern, der ebenfalls als Solenoïd dient, sowie ein Batterietrog zur Fernsteuerung. Komplett mit vollständiger Gebrauchsanweisung. Batterien nicht mit eingeschlossen. Meccano Elektromotoren können von dem Batterietrog ferngesteuert werden, der neun 'Ever Ready' (Berec) HP11 oder entsprechende Batterien enthält und getrennte Umkehrschaltungen von 12 Volt (nominal) und 4½ Volt Gleichstrom liefert. Der Batterietrog ist getrennt erhältlich.

### Elektronisk tillbehörssats-

En fjärrkontroll av Meccano el-motorer. Innehåller en känslig fotocell med avtagbart, lätt hölje, elektriskt relä, lamp och hållare, 12 miniaturstickkontakter, spole med elektrisk ledningstråd och extra skruvar och muttrar. Innehåller också en cylinderspule som genom borttagande av kärnan även kan göra tjänst som elektromagnetisk spira. Därjämte en batterilåda för fjärrmanövrering. Komplet med fullständiga instruktioner. Batteri medföljer ej.

Meccano elektriska motorer kan fjärrmanövreras från batteriboxen, som rymmer 9 'Ever Ready' (Berec) HP11 batterier eller motsvarande och erbjuder från varandra skilda strömkretsar på 12 volts (nominellt) och 4½ volts likström med möjlighet att omkasta strömrättningen. Batteriboxen kan fås separat.

### Juego de accesorios electrónicos-

Para el telecontrol de motores Meccano. Consiste en una fotocélula con envuelta de luz desmontable, relé eléctrico, lámpara y soporte, 12 mini-enchufes, carrete de alambre y tuercas y pernos adicionales. También lleva una bobina cilíndrica con núcleo que hace las veces de solenoide, así como caja de batería para telecontrol e instrucciones completas.

No están incluidas las pilas. Los electromotores Meccano pueden trabajar por telecontrol desde la Caja de Batería, que recibe 9 pilas 'Ever Ready' (Berec) HP11 u otras equivalentes, con circuitos reversibles independientes de 12 voltios (nominal) y 4,5 voltios c.c. La Caja de Batería se suministra aparte.

### Jogo de Acessórios Eletrônico-

Para o controle a distância dos Motores Elétricos Meccano. Contem uma célula foto-elétrica sensível com uma capa removível para a luz, um relé eletrônico, lâmpada e suporte, 12 fichas em miniatura, espiral de fio de ligação e porcas e parafusos adicionais. Contem também uma bobine cilíndrica com um núcleo removível que se duplica como um solenoide e uma caixa de pilhas para comando a distância. É vendido com instruções completas. As pilhas não estão incluídas.

Os motores elétricos Meccano podem funcionar com controle a distância da Caixa de Pilhas que leva 9 pilhas 'Ever Ready' (Berec) HP11 ou equivalentes, dando circuitos reversíveis separados de 12 volts (nominal) e corrente continua de 4½ volts. A Caixa das Pilhas encontra-se à venda em separado.

### Electronic Tilleggssett-

For fjernstyring av Meccano Electric Motors. Settet inneholder en følsom foto-elektrisk celle, med avtakbar lyshette, elektrisk relé, lampe, lampeholder, 12 miniaturpluggar, og ledning, samt skruer og muttre. Inneholder også en sylindrisk kveil med uttakbar jernkjerne som også virker som en solenoïd, og en fjernstyringsboks. Komplet med bruksanvisning. Batterier er ikke inkludert. Meccano Elektriske Motorer kan fjernstyres fra batterikassen, som har plass for 9 'Ever Ready' (Berec) HP11, eller tilsvarende batterier, og gir enten 12 volt, eller 4½ volt d.c. Batterikassen kan kjøpes separat.

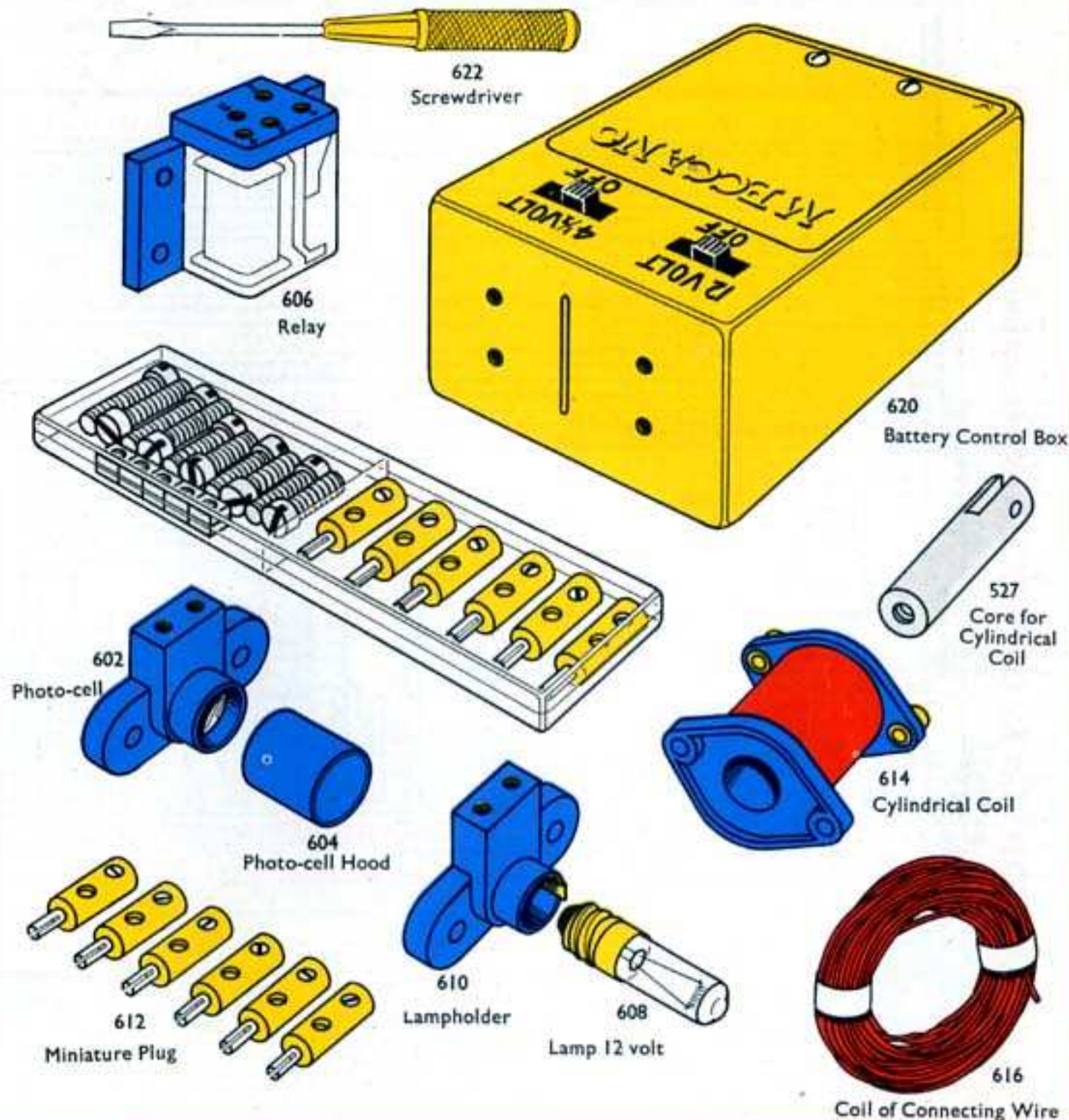

## Put more power and more fun into Meccano models with these electric, clockwork and steam power units.

### ELECTRIC

#### 1. E15R Electric Motor

12/15 volt a.c./d.c. motor with built-in reversing switch. Will operate through a transformer, or will give adequate power when run from suitable batteries.

#### 2. Power Drive Unit (d.c. motor with 6-ratio gearbox)

A precision-made motor with low current consumption. Sturdy and light; performance unaffected by external magnetic fields. Copper-graphite brushes have a life of more than 1,000 hours. Works from current supply of 3 to 12 volts d.c. as supplied by a battery or series of batteries. Gearbox transmission ratios as in 3 below.

#### 3. Power Drive 6-ratio Gearbox with Universal Coupling

A self-contained gearbox with transmission ratios of 3:1, 6:1, 12:1, 16:1, 32:1 and 60:1. Gear ratio may be changed while input drive is operating. Specially designed Universal Coupling enables Gearbox to be driven from any power source using a  $\frac{3}{8}$ " diameter spindle.

## Now you can make the power to work Meccano models

#### 8. Meccano Hand Generator

Compact but powerful it means you make the power for your Meccano models. So easy to operate, it works with the Reversible 4½ volt d.c. Motor and 3-12 volt d.c. Motor with 6-ratio gearbox and will even generate up to 12 volts! All you have to do is just turn the handle. It's simple.

Meccano Electric Motors may be operated remotely from the Battery Box which accommodates 9 'Ever Ready' (Beres) HP11 or equivalent batteries and gives separate reversible circuits of 12 volts (nominal) and 4½ volts d.c. The Battery Box is available separately.

#### 4. Junior Power Drive Unit

A reversible 4½ volt d.c. motor operating from Direct Current of 4½ volts which may be supplied by a battery such as types 1289, F40 or equivalent. It has a stop/forward/reverse lever. The output speed at shaft is 1,000 r.p.m. at 4½ volts.

### CLOCKWORK

#### 5. Magic Motor

Non-reversible. Fitted with brake. Specially intended for driving many of the smaller Meccano models.

#### 6. No. 1 Clockwork Motor

Fitted with reversing mechanism and brake. Suitable for driving many of the larger Meccano models.

### STEAM

#### 7. Steam Engine

Gives super-efficient steam power to drive through gears, chains and pulleys. Works on water heated by methylated spirits burner. Control lever operates fly-wheel in forward or reverse directions.

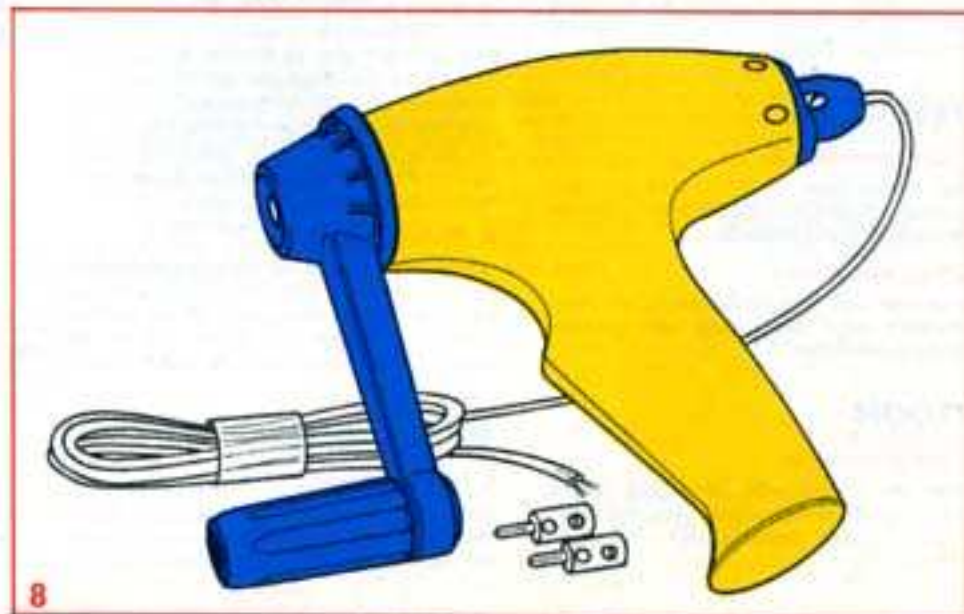
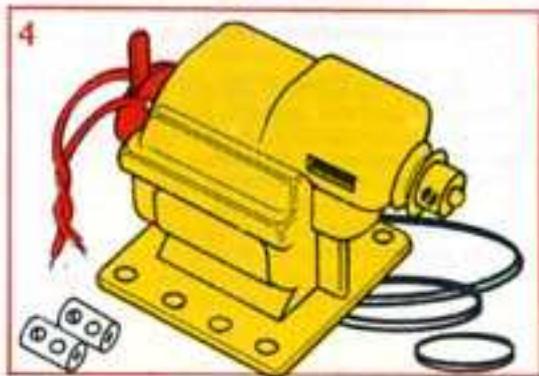
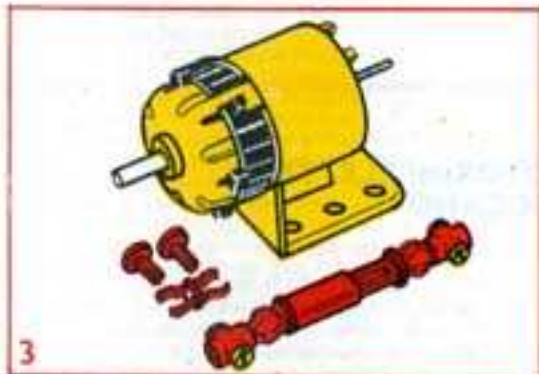
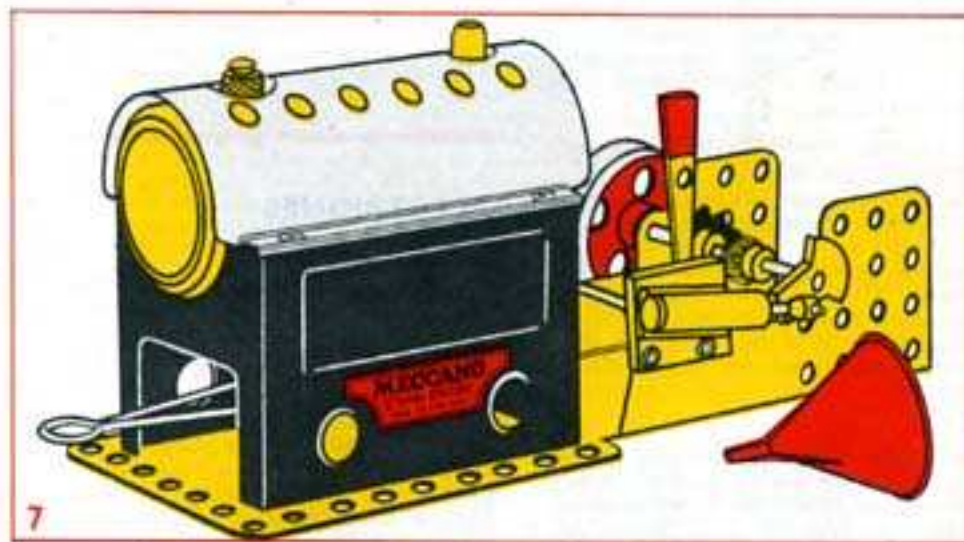
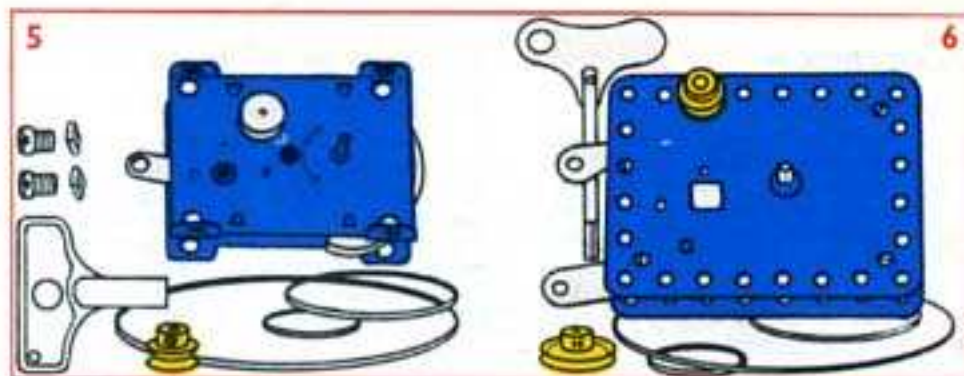
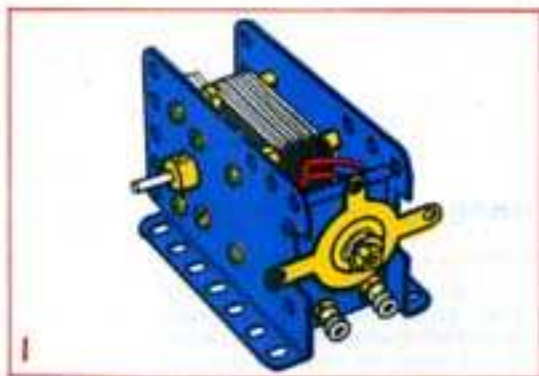

## ELECTRISCH

### 1. E15R Electromotor

12/15 Volt wissel-en gelijkstroom motor met ingebouwde omkeerschakelaar. Kan worden aangesloten op een transformator en levert ook voldoende vermogen, wanneer de stroom door passende batterijen wordt geleverd.

### 2. Motor met variabele vertraging (Gelijkstroom motor met 6 verschillende overbrengingen)

Een precisie motor voor lage spanningen. Stevig en licht. Kopergrafiet borstels met een levensduur van meer dan 1.000 uren. Loopt op een gelijkstroom van 3 tot 12 volt, die wordt geleverd door batterijen in serie te schakelen. Overbrengingen in de vertragingkast als bij 3.

### 3. 6-voudige vertragingkast met universeelkoppeling

Een vertragingkast met de volgende overbrengingsverhoudingen: 3:1, 6:1, 12:1, 16:1, 32:1 en 60:1. De overbrenging kan worden gewijzigd bij draaiende aandreven as. De speciale dubbele kruiskoppeling maakt het mogelijk om de vertragingkast aan te drijven met een willekeurige krachtbron, met een asdiameter van 4 mm.

### 4. D.C. motor

Een omkeerbare 4½ volt gelijkstroom motor, die kan worden gevoed met een batterij van 4½ volt. Bij 4½ volt spanning maakt de aandrijfas 1.000 toeren per minuut. Door middel van een handel kunnen drie keuzestanden worden gekozen: vooruit, stilstand en achteruit.

## VEERWERK

### 5. Tovermotor

Niet omkeerbaar. Uitgerust met een rem. Speciaal bedoeld voor de aandrijving van de kleinere Meccano modellen.

### 6. Veermotor no. 1

Uitgerust met omkeerinrichting en rem. Geschikt voor aandrijving van grotere Meccano modellen.

## STOOM

### 7. Stoommachine

Door de ingebouwde vertraging levert deze voldoende vermogen voor het aandrijven van middelgrote Meccano modellen.

Door middel van een hefboom kan de machine voorof achteruit lopen.

### 8. Meccano Hand Generator —

Klein maar krachtig. Hiermede wék je zelf de kracht op voor je Meccano modellen. Gemakkelijk te bedienen; levert stroom voor de d.c. motor en de motor met vertragingkast (2) tot 12 volt toe! Alles wat je te doen hebt is de kruk te draaien. Eenvoudiger kan het niet. De elektrische Meccano motoren kunnen op afstand worden bediend door middel van het batterijhuis, dat plaats biedt aan 9 staalbatterijen van 1½ volt. Hiermede kan tegelijkertijd 12 en 4½ volt gelijkstroom worden afgegeven; voor beide is ook omkering van de stroomrichting mogelijk.

## ELECTRIQUES

### 1. Moteur électrique E15R

Moteur 12/15 volts, alternatif ou continu, avec renversement de marche incorporé. Fonctionne sur transformateur ou piles.

### 2. Moteur électrique avec boîte à 6 vitesses

Moteur puissant, de faible consommation. Robuste et léger. Balais de graphite cuivré d'une durée supérieure à 1.000 heures. Marche sur 3 à 12 volts, courant continu, à l'aide d'une ou plusieurs piles. Rapports identiques au No. 3.

### 3. Boîte à vitesses avec accouplement universel

Rapports 3:1, 6:1, 12:1, 16:1, 32:1 et 60:1. Possibilité de changer de vitesse sans arrêter le moteur. Accouplement universel spécialement étudié permettant d'entraîner la boîte de vitesses à partir de toute source de puissance possédant un axe de 4 mm de diamètre.

### 4. Moteur électrique

4,5 volts, continu, à marche avant et arrière. Fonctionne sur pile ref. 12B9, F40 ou l'équivalent. Marches avant et arrière, et arrêt commandés par levier. Vitesse de rotation: 1.000 tours/minute sous 4,5 volts.

## MECANIQUES

### 5. Moteur Magic

Sans renversement de marche. Frein incorporé. Spécialement étudié pour animer certains modèles de petites boîtes Meccano.

### 6. Moteur No. 1

A renversement de marche. Frein incorporé. Convient parfaitement aux modèles plus importants.

## A VAPEUR

### 7. Machine à vapeur

Fournit une puissance-vapeur largement suffisante pour entraîner engrenages, chaînes et poulies. Fonctionne à l'alcool à brûler et à l'eau. Un levier unique commande la marche avant, arrière et la vitesse du volant d'entraînement.

### 8. Générateur Meccano —

petit mais puissant, il vous permet de fournir à vos modèles Meccano le courant électrique nécessaire. D'emploi très simple, il peut alimenter le moteur électrique 4,5 volts et le moteur électrique avec boîte à 6 vitesses et fournira même jusqu'à 12 volts! Vous n'avez qu'à tourner la manivelle: rien de plus simple!

Les moteurs électriques Meccano peuvent fonctionner à distance sur batterie à 9 piles "Ever Ready" (Ereco) HP11 (ou similaires) donnant à volonté 12 volts et 4,5 volts, continu. Le batterie à piles est disponible séparément.

## MOTORINI ELETTRICI MECCANO

### 1. Motorino Elettrico E15R

12/15 volts c.a./c.c. — Munito di leva per la messa in moto, l'arresto e l'inversione della marcia. Funziona sulla corrente elettrica alternata mediante un trasformatore adatto. Può anche essere fatto funzionare da batterie adatte.

### 2. Motorino Elettrico c.c. con cambio a 6 velocità

Un motorino elettrico super-efficiente e a basso consumo di corrente, leggero, ma di precisa e robusta costruzione. In questo motorino sono eliminate le dispersioni di campo magnetico verso l'esterno. Le spazzole di grafite ramata hanno una durata di funzionamento di più di 1.000 ore. Funziona su corrente continua da 3 a 12 volts fornita da una o più comuni pile a secco tascabili. Rapporti di velocità come al paragrafo 3.

### 3. Cambio a 6 Velocità con Giunto Universale

Rapporti di trasmissione: 3:1, 6:1, 12:1, 16:1, 32:1 e 60:1. Si possono cambiare le velocità anche quando il motorino è in moto. Il giunto universale di speciale concezione permette di collegare direttamente il cambio a 6 velocità a qualsiasi motorino usando un asse di mm 4 di diametro.

### 4. Motorino Elettrico Junior

Munito di leva per la messa in moto, l'arresto e l'inversione della marcia. Funziona su corrente continua a 4½ volts fornita da una comune pila a secco tascabile. La velocità dell'albero motore è di 1.000 giri al minuto a 4½ volts.

## MOTORINI A MOLLA MECCANO

### 5. Motorino Magic

Sola marcia avanti. Munito di leva di arresto. Adatto per far funzionare molti dei modelli Meccano più piccoli.

### 6. Motorino a Molla No. 1

Munito di leva per la messa in moto, l'arresto e l'inversione della marcia. Adatto per far funzionare molti dei modelli più grandi.

## VAPORE

### 7. Motrice a Vapore Meccano

Fornisce super-efficiente forza motrice a vapore per azionare i vostri modelli mediante trasmissioni ad ingranaggi, a catena o su pulegge. Funziona ad acqua riscaldata da un bruciatore ad alcool metilico. Una leva comanda la rotazione del volante sia in avanti che all'indietro.

### 8. Generatore Meccano a Mano —

Compatto ma potente — vi dà la possibilità di creare voi stessi la forza motrice per i vostri modelli Meccano. Di facilissimo uso per far funzionare il Motorino Elettrico Junior e il Motorino Elettrico con cambio a 6 velocità. Genererà corrente elettrica fino a 12 volts. Tutto quello che avrete da fare è solo girare la manovella. E' semplicissimo. I Motorini Elettrici Meccano possono essere fatti funzionare a distanza per mezzo della Scatola Portatile che può contenere 9 pile adatte e fornisce circuiti separati invertibili a 12 volts (nominali) e 4½ volts corrente continua. La Scatola Portatile si fornisce separatamente.

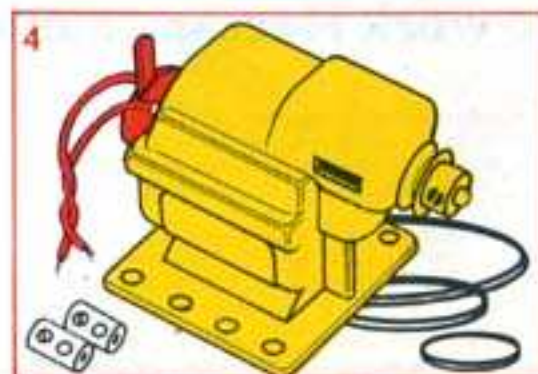
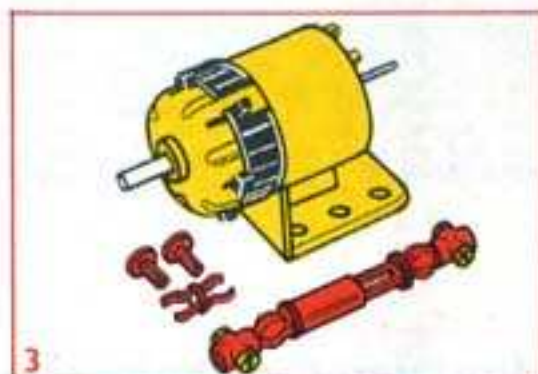
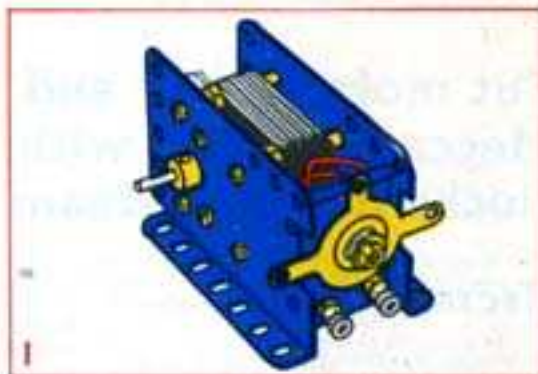



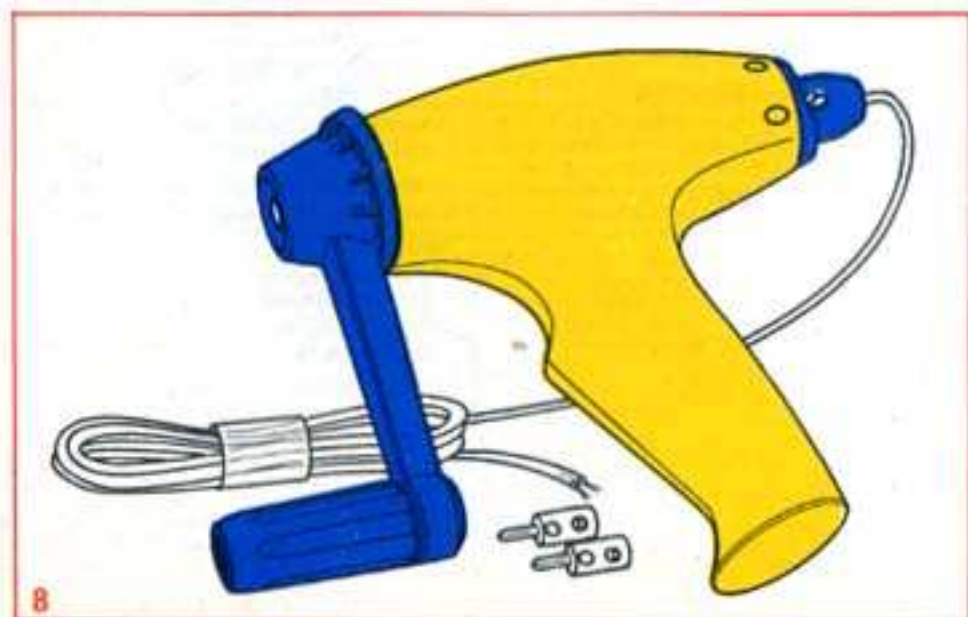
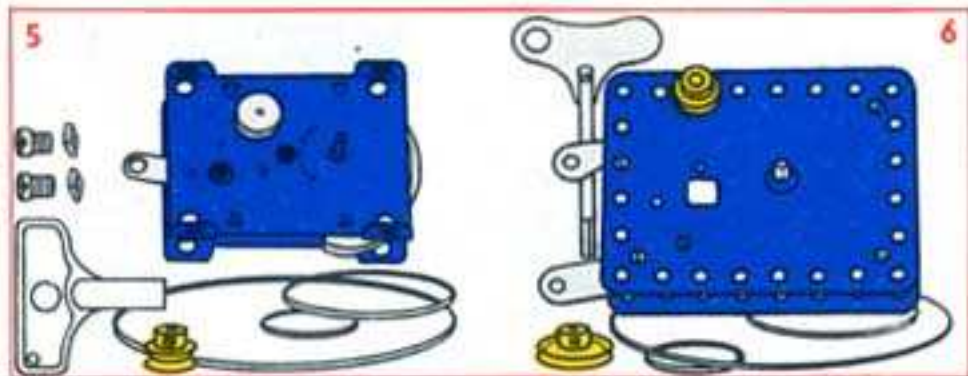

## ELEKTRISCH

### 1. E15R Elektromotor

12/15 volt Wechselstrom/Gleichstrommotor mit eingebautem Umkehrschalter. Funktioniert mittels eines Transformators oder liefert eine angemessene Antriebsleistung bei Speisung durch geeignete Batterien.

### 2. Antriebseinheit (Gleichstrommotor mit 6-Gang-Getriebe)

Ein Präzisionsmotor mit geringem Stromverbrauch. Stabil und leicht: trotz äußerer Magnetfelder gleichbleibende Leistung. Kupfergraphit Bürsten mit einer Lebensdauer von mehr als 1.000 Stunden. Arbeitet mit 3-12 Volt Gleichstrom, aus einer Batterie bzw. einer Reihe von Batterien, Übersetzungsverhältnis wie in 3.

### 3. 6-Gang-Getriebe mit Universalkupplung

Ein in sich abgeschlossenes Getriebe mit einem Übersetzungsverhältnis von 3:1, 6:1, 12:1, 16:1, 32:1 und 60:1. Übersetzungsverhältnis kann bei laufendem Motorantrieb geändert werden. Dank einer speziell konstruierten Universalkupplung läuft das Getriebe mit Hilfe beliebiger Antriebsquellen, die eine Spindel mit einem Durchmesser von 4 mm verwenden.

### 4. Junior Antriebseinheit

Ein 4½ volt Gleichstrom Umkehrmotor, konstruiert für den Betrieb bei 4½ volt Gleichstrom, der von einer Batterie der Typen 1289, F40 oder entsprechend geliefert wird. Mit einem Hebel für Anhalten und Fahrtrichtungswechsel versehen. Die Antriebswellendrehzahl beträgt 1.000 Umdrehungen/min. bei 4½ volt.

## UHRWERKMOTOR

### 5. Zauber-Motor

Kein Umkehrmotor. Mit Bremse ausgerüstet. Speziell für den Antrieb vieler der kleineren Meccano Modelle gedacht.

### 6. Nr. 1 Uhrwerkmotor

Mit Umkehrmechanismus und Bremse ausgerüstet. Für den Antrieb vieler der grösseren Meccano Modelle geeignet.

## DAMPFANTRIEB

### 7. Dampfmaschine

Liefert besonders leistungsstarken Dampftrieb für Zahnräder, Ketten und Rie-

menscheiben! Arbeitet mit auf einem Spiritusbrenner erhitzten Wasser. Hebel zur Steuerung des Schwungrads in Vorwärts- oder Rückwärtsrichtung.

### 8. Meccano Hand Generator

— kompakt, aber leistungsstark; nun können auch Sie die Antriebskraft für Ihre Meccano Modelle erzeugen. Ausgesprochen leicht zu bedienen; arbeitet zusammen mit der Junior Antriebseinheit und der Antriebseinheit; erzeugt sogar bis zu 12 volt! Sie brauchen nur am Griff zu drehen. Einfacher geht es wirklich nicht.

Meccano Elektromotoren können von einem Batterietrog ferngesteuert werden, der neun 'Ever Ready' (Berec) HP11 oder entsprechende Batterien enthält und getrennte Umkehrschaltungen von 12 volt (nominal) und 4½ volt Gleichstrom liefert. Der Batterietrog ist getrennt erhältlich.

## EL-DRIVNA KRAFTKALLOR

### 1. E15R el-motor

12-15 volts växelströms-/likströmsmotor med inbyggt backslag. Drivs med transformator eller med lämpliga batterier, som ger den motsvarande styrka.

### 2. Likströmsmotor jämte växellåda med sex lägen

En precisionstillverkad motor med låg strömförbrukning. Kraftig men lätt. Störes ej av utomliggande magnetfält. Kolen av koppargrafit har en varaktighet av mer än 1.000 timmar. Går på likström från 3-12 volts batteri eller från seriekopplade batterier. Växellådans utväxlingsförhållanden desamma som under 3 nedan.

### 3. Växellåda för 6 hastigheter med universalkoppling

En kapslad växellåda med utväxlingsförhållandena 3:1, 6:1, 12:1, 16:1, 32:1 och 60:1. Utväxlingsförhållandet kan ändras medan motorn är i gång. Den specialkonstruerade universalkopplingen gör att växellådan kan drivas från varje kraftkälla med 4 mm s spindel.

### 4. Junior el-motor

En 4½ volts likströmsmotor med backslag. Drivs med batteri 1289, F40 eller motsvarande. Har spåk för stopp, fram och back. Drivaxeln gör 1.000 varv per minut då motorn matas med ett 4½ volts batteri.

## URVERK

### 5. Magic motor

Ej omställbar till motsatt rotationsriktning. Försedd med broms. Särskilt avsedd att driva de mindre Meccano-modellerna.

### 6. Urverksmotor

Försedd med backslag och broms. Lämplig att driva många av de större Meccano-modellerna.

## ANGKRAFT

### 7. Angmaskin

Ger högeffektiv ångkraft för drift medelst kugghjul, kedjor och remskivor. Drivmedlet är vatten som upphetas av en spritlåga. Med en spåk ger man svänghjulet önskad rotationsriktning.

### 8. Meccano handgenerator

kompart men med hög effekt — gör Dig själv till den som lämnar kraften till Dina Meccano-modeller. Lätt att driva, den arbetar med 'Junior el-motor' och likströmsmotoraggregatet och kan t.o.m. alstra en spänning av upp till 12 volt. Allt Du behöver göra är att vrida på handtaget. Det är enkelt.

Meccano elektriska motorer kan fjärrmanövreras från batteriboxen, som rymmer 9 'Ever Ready' (Berec) HP11 batterier eller motsvarande och erbjuder från varandra skilda strömkretsar på 12 volts (nominellt) och 4½ volts likström med möjlighet att omkasta strömriktningen. Batteriboxen kan lös separat.

## ELECTRICIDAD

### 1. Electromotor E15R

Motor de 12/15 voltios c.a./c.c. con conmutador inversor incorporado. Previsto para funcionar a través de transformador o mediante pila, suministrando amplia potencia en ambos casos.

### 2. Grupo 'Power Drive' (motor de c.c. y caja de 6 velocidades)

Motor de gran precisión y de bajo consumo de corriente. Robustez combinada con peso reducido; inafectado por campos magnéticos externos. Las escobillas de cobre y grafito duran más de 1.000 horas. Trabaja con corriente continua de 3 a 12 voltios suministrada por una o varias pilas. Desmultiplicaciones de la caja de velocidades como en el apartado 3.

### 3. 'Power Drive' caja de 6 velocidades con junta universal

Caja de engranajes independiente con desmultiplicaciones de 3:1, 6:1, 12:1, 16:1, 32:1 y 60:1. Se puede variar la desmultiplicación en régimen de entrada de potencia. La junta universal, expresamente ideada para esta caja, permite accionar la misma desde cualquier fuente de energía utilizando un eje de 4mm. Ø.

### 4. Grupo 'Junior Power Drive'

Motor reversible de 4,5 voltios c.c. para su uso con pilas que suministren dicha corriente, como las versiones 1289, F40 u otras equivalentes. Palanca de avance/parada/inversión. A 4,5 voltios el eje de salida gira a 1.000 r.p.m.

## CUERDA

### 5. Motor 'Magic'

Irreversible, equipado con freno. Ideado expresamente para impulsar muchos de los pequeños modelos Meccano.

### 6. Motor de cuerda No. 1

Con mecanismo inversor y freno. Apto para impulsar muchos de los grandes modelos Meccano.

## VAPOR

### 7. Máquina de vapor

Tracción a vapor super-eficiente, a través de engranajes, cadenas y poleas. Trabaja con agua calentada por quemador de alcohol. La palanca de mando impulsa el volante en dirección de avance o inversión.

### 8. Generador de manivela Meccano —

compacto pero potente. Le permite generar la potencia necesaria para sus modelos Meccano. Manejo facilísimo, trabaja con los motores Meccano de 4½ V.c.c. y de 3-12 V.c.c. (produce hasta 12 voltios! Sólo hay que impulsar la manivela. No podía ser más sencillo.

Los electromotores Meccano pueden trabajar por telecontrol desde la Caja de Batería, que recibe 9 pilas 'Ever Ready' (Berec) HP11 u otras equivalentes, con circuitos reversibles independientes de 12 voltios (nominal) y 4,5 voltios c.c. La Caja de Batería se suministra aparte.

## MOTORES ELÉCTRICOS

### 1. Motor Eléctrico E15R

Motor de c.c./c.c. de 12/15 voltios con interruptor embutido de inversión. Pude funcionar através de un transformador e dá também energia suficiente quando trabalha com pilhas próprias.

### 2. Unidade de Accionamento (motor de c.c. com uma caixa de seis velocidades)

Motor feito a precisão com um consumo de corrente baixo. Resistente e leve: o rendimento não é afectado por campos magnéticos exteriores. As escovas de cobre-grafite têm uma vida superior a 1.000 horas de funcionamento. Trabalha com uma corrente continua de 3 a 12 volts fornecida por uma pilha ou uma série de pilhas. As relações de transmissão são idênticas às apresentadas em 3.

### 3. Caixa de 6 Velocidades com Junta Universal

É uma caixa de velocidades auto-suficiente com relações de transmissão de 3:1, 6:1, 12:1, 16:1, 32:1 e 60:1. A velocidade pode ser mudada enquanto o accionamento primário está a funcionar. A Junta Universal de desenho especial habilita a Caixa de Velocidades a ser accionada por qualquer fonte de energia através de uma cavilha de 4mm. de diâmetro.

### 4. Unidade de Accionamento Junior

É um motor a c.c. de 4½ volts reversível que funciona com uma corrente contínua de 4½ volts fornecida por uma pilha dos tipos 1289, F40 ou equivalentes. Tem uma alavanca de paragem/marcha à frente/marcha atrás. A velocidade de saída do veio é de 1.000 rpm a 4½ volts.

## MOTORES DE CORDA

### 5. Motor Mágico

Não é reversível. É montado com travão. Concebido especialmente para accionar muitos dos modelos de Meccano mais pequenos.

### 6. Motor de Corda No. 1

Montado com um mecanismo de inversão e travão. É próprio para accionar muitos dos modelos maiores de Meccano.

## MOTORES A VAPOR

### 7. Motor a Vapor

Fornece vapor com uma potência super-eficiente para accionar por meio de engranagens, correntes e polias. Trabalha com água aquecida por meio de um queimador de álcool desnaturalado. A alavanca de controle acciona o volante do motor para marcha a frente ou atrás.

### 8. Gerador Manual Meccano —

compacto mas potente—significa que você pode produzir a energia necessária para pôr os seus modelos de meccano a trabalhar. É tão fácil usá-lo; tanto pode trabalhar com um motor Meccano de 4½ voltios c.c. como com um motor de 3-12 voltios c.c. podendo gerar até 12 volts. Tudo quanto há a fazer é rodar o manípulo. Simples, sem dúvida.

Os motores eléctricos Meccano podem ser operados por controle a distância da Caixa das Pilhas que usa 9 pilhas 'Ever Ready' (Berec) HP11 ou equivalentes, dando circuitos reversíveis separados de 12 voltios (nominal) e c.c. de 4½ voltios. A Caixa das Pilhas encontra-se à venda em separado.

## ELEKTRISK

### 1. E15R Elektrisk Motor

12/15 Volt a.c./d.c. motor med innebygget revers bryter. Kan Kjøres ved hjelp av transformator, eller batterier.

### 2. Power Drive Unit (D.C. motor med 6-trinns gearboks)

En presisjonsmotor med lavt strømforbruk, stabil og lett, og går uberørt av magnetiske felt. Kobbergrafitt børstene har en levetid

på mer enn 1.000 timer, og motoren går ved hjelp av batterier på fra 3 til 12 Volt d.c. Gearboksen er bygget som nevnt under punkt 3.

### 3. Power Drive 6-trinns Gearboks med universal-kobling

En gearboks med overførseler som forholder seg slik: 3:1, 6:1, 12:1, 16:1, 32:1, og 60:1. Gearforholdene kan skiftes mens motoren går.

### 4. Junior Power Drive Unit

En reversebar 4½ Volt d.c. motor, som går ved hjelp av likestrøms-batterie på 4½ volt. (Type 1289, F40 eller likn.). Den har en stopp/forover/revers bryter. Farten ved 4½ volt kan bli 1.000 omdreinger pr. min.

## OPPTREKSMOTOR

### 5. Magic Motor

Ikke reverserbar, leveres med brems, og er mest anvendelig for mindre Meccano-modeller.

### 6. No. 1 Clockwork Motor

Utstyrt med reverseringsmuligheter og brems, og kan brukes også på større Meccano-modeller.

## DAMPMASKIN

### 7. Steam Engine

Denne dampmaskin gir kraft som kan brukes til å dra gear og kjeder. Opererer ved at vann varmes opp med en sprit-brenne.

### 8. Meccano Hand Generator —

kompakt men kraftig — betyr at du lever kraften som skal dra dine Meccano-modeller. Meget enkel å betjene, og kan lade opp til 12 Volt. Alt du har å gjøre er å skru på bryteren—det er det hele!

Meccano Elektriske Motorer kan fjernstyres fra batterikassen, som har plass for 9 'Ever Ready' (Berec) HP11, eller tilsvarende batterier og gir enten 2x4½ Volt eller 1x9 volt d.c. Batterikassen kan kjøpes separat.

# MECCANO

## BASIC SETS

No.1	No.2	No.3
No.4	No.5	No.6
No.7	No.8	No.9
No.10 Meccano in 4-Drawer Cabinet		

## CONVERSION SETS

No.1x	Converts No.1 into No.2
No.2x	Converts No.2 into No.3
No.3x	Converts No.3 into No.4
No.4x	Converts No.4 into No.5
No.5x	Converts No.5 into No.6
No.6x	Converts No.6 into No.7
No.7x	Converts No.7 into No.8
No.8x	Converts No.8 into No.9

## SPECIAL SETS

No.3M	No.4M	No.4EL	No.5ME
Gear Set			
Mechanisms Set			
Super Tool Set			
Electronics			

## MOTORS, ETC.

Magic Clockwork Motor, non-reversing (including key)
No.1 Clockwork Motor, reversing (including key)
Reversible 4½-v. D.C. Motor
3-12 volt D.C. Motor with 6-ratio Gearbox
6-ratio Gear Box with Universal Coupling
E15R Electric Motor with reversing switch†
Steam Engine
43,901 B Key for No.1 Clockwork Motor
43,903 S Key for Magic Clockwork Motor
Low Voltage Hand Generator

Please ask for advice regarding the most suitable Transformer for use with E15R Motor.

† Fitted with T.V. and Radio interference suppressors.



**51**  
**FLANGED PLATES**  
 51 - 2½" × 1½"; 60 × 38 mm  
 52 - 5½" × 2½"; 14 × 6 cm  
 53 - 3½" × 2½"; 9 × 6 cm



**52**  
**FLAT PLATES**  
 52a - 5½" × 3½"; 14 × 9 cm  
 53a - 4½" × 2½"; 11½ × 6 cm



**54** - 4½"; 115 mm  
**FLANGED SECTOR PLATE**



**PERFORATED SLOTTED STRIP**  
 55 - 5½"; 14 cm  
 55a - 2"; 5 cm



**57b**  
**HOOK**



**57c**  
**HOOK**



**57d**  
**WIRE HOOK**



**58** **SPRING CORD** - 40"; 1 metre



**59**  
**COLLAR WITH SCREW**



**61**  
**WINDMILL SAIL**



**62**  
**CRANK**



**62a**  
**THREADED CRANK**



**62b**  
**DOUBLE ARM CRANK**



**63**  
**COUPLING**



**63b**  
**STRIP COUPLING**



**63c**  
**THREADED COUPLING**



**63d**  
**SHORT COUPLING**



**64**  
**THREADED BOSS**



**65**  
**CENTRE FORK**



**69** - ½"; 4 mm  
**SET SCREW**

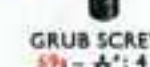

**69a** - ½"; 4 mm  
**69b** - ⅝"; 5 mm  
**69c** - ⅜"; 3 mm  
**GRUB SCREWS**



**70** - 5½" × 2½"; 14 × 6 cm  
**72** - 2½" × 2½"; 6 × 6 cm  
**73** - 3" × 1½"; 75 × 38 mm  
**74** - 1½" × 1½"; 38 × 38 mm  
**FLAT PLATES**

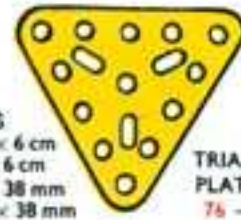

**76** - 2½"; 6 cm  
**77** - 1"; 25 mm  
**TRIANGULAR PLATES**



**78** - 1½"; 29 cm  
**79** - 8"; 20 cm  
**79a** - 6"; 15 cm  
**80** - 5"; 12½ cm  
**80a** - 3½"; 9 cm  
**80b** - 4½"; 11½ cm  
**80c** - 3"; 7½ cm  
**81** - 2"; 5 cm  
**82** - 1"; 25 mm  
**SCREWED RODS**



**89** - 5½"; 14 cm  
**90** - 2½"; 6 cm  
**89a** - 3"; 7½ cm  
**89b** - 4"; 10 cm  
**90a** - 2½"; 6 cm  
**CURVED STRIP**  
**CURVED STRIP STEPPED**



**94** - 40"; 1 metre  
**SPROCKET CHAIN**



**95** - 2"; 5 cm  
**95a** - 1½"; 38 mm  
**95b** - 3"; 75 mm  
**96** - 1"; 25 mm  
**96a** - 2"; 19 mm  
**SPROCKET WHEELS**

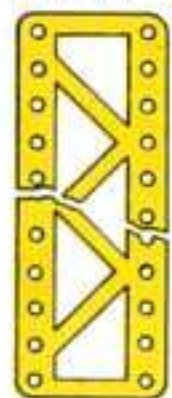

**97** - 3½"; 9 cm  
**99** - 1½"; 32 cm  
**99a** - 9½"; 24 cm  
**99b** - 7½"; 19 cm  
**100** - 5½"; 14 cm  
**BRACED GIRDERS**



**101**  
**HEALD FOR LOOM**



**102**  
**SINGLE BENT STRIP**



**103** - 5½"; 14 cm  
**103a** - 9½"; 24 cm  
**103b** - 12½"; 32 cm  
**103c** - 4½"; 11½ cm  
**103d** - 3½"; 9 cm  
**103e** - 3"; 7½ cm  
**103f** - 2½"; 6 cm  
**103g** - 2"; 5 cm  
**103h** - 1½"; 38 mm  
**103i** - 1½"; 19 cm  
**103k** - 7½"; 19 cm  
**FLAT GIRDERS**



**106**  
**WOOD ROLLER**

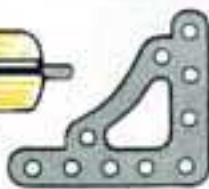

**108**  
**CORNER GUSSET**



**109** - 2½"; 6 cm  
**FACE PLATE**



**110** - 3½"; 9 cm  
**110a** - 6½"; 16½ cm  
**RACK STRIPS**

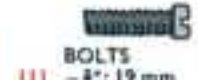

**111** - 2"; 19 mm  
**111a** - 1"; 12 mm  
**111c** - 1"; 9½ mm  
**111d** - 1½"; 28½ mm  
**BOLTS**



**123** - 1½" × 1" × 2"; 32 × 25 × 19 mm  
**CONE PULLEY**



**124** - 1"; 25 mm  
**125** - ½"; 12 mm  
**REVERSED ANGLE BRACKETS**



**126**  
**TRUNNION**



**126a**  
**FLAT TRUNNION**



**128**  
**BELL CRANK**



**130** - 1" × 1" × 1"; 6 × 9 × 12 mm  
**ECCENTRIC TRIPLE THROW**



**130a** - ½"; 6 mm  
**ECCENTRIC SINGLE THROW**



**131**  
**CAM**



**133** - 1½"; 38 mm  
**133a** - 1"; 25 mm  
**CORNER BRACKETS**



**116a**  
**FORK PIECE LARGE**



**116b**  
**FORK PIECE SMALL**



**118** - 5½"; 14 cm  
**HUB DISC**



**120b** - ⅝"; 14 mm  
**COMPRESSION SPRING**



**122**  
**LOADED SACK**



**137**  
**WHEEL FLANGE**



**138**  
**SHIP'S FUNNEL**



**139** (right)  
**139a** (left)  
**FLANGED BRACKET**



**140**  
**UNIVERSAL COUPLING**



**142a** - 2"; 5 cm  
**142b** - 3"; 7½ cm  
**142c** - 1"; 25 mm  
**142d** - 1½"; 38 mm  
**MOTOR TYRES**



**143** - 5½"; 14 cm  
**CIRCULAR GIRDER**



**144**  
**DOG CLUTCH**



**145** - 7½"; 19 cm  
**CIRCULAR STRIP**



**136**  
**HANDRAIL SUPPORT COUPLING**



**136a**  
**HANDRAIL COUPLING**

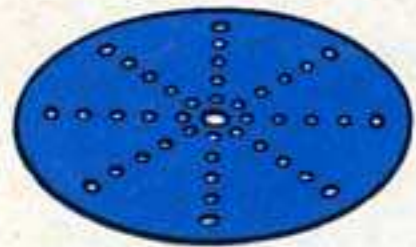

**CIRCULAR PLATES**  
146a - 4"; 10 cm  
146 - 6"; 15 cm



**PAWL WITH PIVOT BOLT & NUTS**  
147



**PAWL**  
147a



**PIVOT BOLT**  
147b



**147c PAWL WITHOUT BOSS**



**RATCHET WHEEL**  
148



**PULLEY BLOCKS**  
153 TRIPLE  
151 SINGLE



**CORNER ANGLE BRACKET**  
154a - 1/2"; 12 mm (right)  
154b - 1/2"; 12 mm (left)



**RUBBER RING**  
155 - 1"; 25 mm



**FAN**  
157 - 2"; 5 cm



**CHANNEL BEARING**  
160 - 1 1/2" x 1" x 1/2";  
38 x 25 x 12 mm



**GIRDER BRACKET**  
161 - 2" x 1" x 1/2";  
50 x 25 x 12 mm

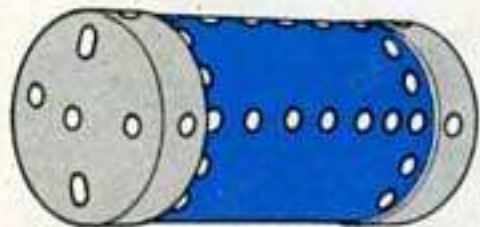

**BOILER**  
162 BOILER COMPLETE - 5" x 2 1/2"; 12 1/2 x 5 cm  
162a BOILER END - 2 1/4" x 1/2"; 50 x 19 mm



**SLEEVE PIECE**  
163 - 1 1/2" x 1 1/2";  
38 x 17 mm



**CHIMNEY ADAPTOR**  
164 - 1/2" x 1/2";  
16 x 12 mm



**SWIVEL BEARING**  
165



**END BEARING**  
166



**LARGE TOOTHED QUADRANT PINION**  
167c



**FLANGED RING**  
167b - 9 1/2"; 25 cm



**LARGE TOOTHED QUADRANT**  
167a



**168 BALL THRUST BEARING COMPLETE** 4"; 10 cm  
168a AND 168b BALL THRUST RACES  
168c BALL CAGE



**168d BALL**  
1/2"; 9 1/2 mm



**172a ADAPTOR FOR SCREWED ROD**



**171 SOCKET COUPLING**



**176 ANCHORING SPRING**



**179 ROD SOCKET**



**175 FLEXIBLE COUPLING UNIT**



**GEAR RING**  
180 - 3 1/2"; 9 cm



**STEERING WHEELS**  
185 - 1 1/2"; 4 1/2 cm  
185a - 2 1/2"; 60 mm



**DRIVING BANDS**  
light heavy  
186 - 2 1/2"; 6 cm 186c - 10"; 25 cm  
186a - 6"; 15 cm 186d - 15"; 37 1/2 cm  
186b - 10"; 25 cm 186e - 20"; 50 cm



**ROAD WHEELS**  
187 - 2 1/2"; 60 mm  
187b - 4 1/2"; 100 mm



**CONICAL DISC**  
187a - 1 1/2"; 47 mm

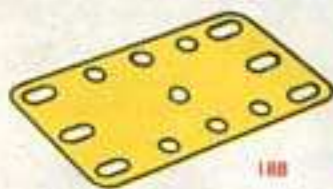

**FLEXIBLE PLATES**  
188 - 2 1/2" x 1 1/2"; 60 x 38 mm  
189 - 5" x 1 1/2"; 140 x 38 mm  
190 - 2 1/2" x 2 1/2"; 6 x 6 cm  
190a - 3 1/2" x 2 1/2"; 9 x 6 cm  
191 - 4 1/2" x 2 1/2"; 11 1/2 x 6 cm  
192 - 5 1/2" x 2 1/2"; 14 x 6 cm

**BLUE PLASTIC PLATES**  
194 - 2 1/2" x 1 1/2"; 60 x 38 mm  
194a - 2 1/2" x 2 1/2"; 60 x 60 mm  
194b - 3 1/2" x 2 1/2"; 90 x 60 mm  
194c - 4 1/2" x 2 1/2"; 115 x 60 mm  
194d - 5 1/2" x 2 1/2"; 140 x 38 mm  
194e - 5 1/2" x 2 1/2"; 140 x 60 mm



**STRIP PLATES**  
195 - 7 1/2" x 2 1/2"; 19 x 6 cm  
196 - 9 1/2" x 2 1/2"; 24 x 6 cm  
197 - 12 1/2" x 2 1/2"; 32 x 6 cm

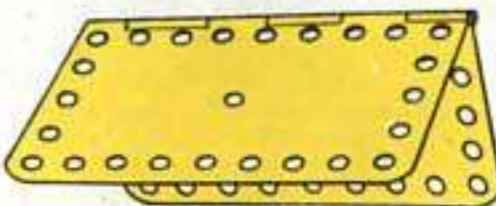

**HINGED FLAT PLATE**  
198 - 4 1/2" x 2 1/2"; 11 1/2 x 6 cm

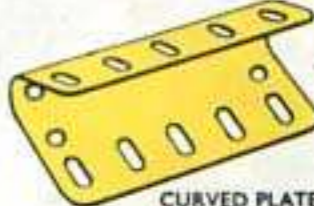

**CURVED PLATE U SECTION**  
199 - 2 1/2" x 2 1/2" x 1/8";  
60 x 60 x 7 mm

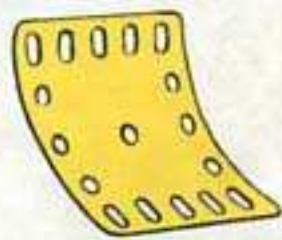

**CURVED PLATE**  
200 - 2 1/2" x 2 1/2" x 1 1/8";  
60 x 60 x 43 mm

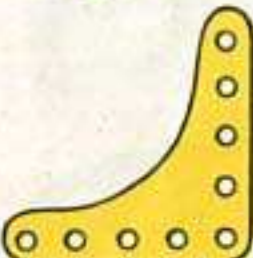

**FLEXIBLE GUSSET PLATE**  
201 - 2 1/2" x 2 1/2";  
60 x 60 mm



**HELICAL GEARS**  
211a - 1/2"; 12 mm  
211b - 1/2"; 38 mm  
can only be used together.



**212 ROD AND STRIP CONNECTOR**



**212a ROD AND STRIP CONNECTOR RIGHT ANGLE**



**213**

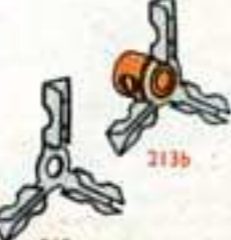

**ROD CONNECTORS**



**SEMI-CIRCULAR PLATE**  
214 - 2 1/2"; 6 cm

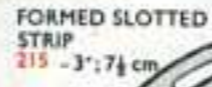

**FORMED SLOTTED STRIP**  
215 - 3"; 7 1/2 cm



**CYLINDER**  
216 - 2 1/2" x 1 1/2";  
60 x 30 mm



**TRIANGULAR FLEXIBLE PLATES**  
221 - 2 1/2" x 1 1/2"; 60 x 38 mm  
222 - 2 1/2" x 2"; 60 x 50 mm  
223 - 2 1/2" x 2 1/2"; 60 x 60 mm  
224 - 3 1/2" x 1 1/2"; 90 x 38 mm  
225 - 3 1/2" x 2"; 90 x 50 mm  
226 - 3 1/2" x 2 1/2"; 90 x 60 mm



**KEY BOLT**  
231



**ROD WITH KEYWAY**  
230 - 4"; 10 cm



**NARROW STRIPS**  
235 - 2 1/2" x 1/4"; 60 mm x 9 mm  
235a - 3" x 1/4"; 75 mm x 9 mm  
235b - 3 1/2" x 1/4"; 90 mm x 9 mm  
235c - 4 1/2" x 1/4"; 115 mm x 9 mm  
235d - 5 1/2" x 1/4"; 140 mm x 9 mm