

MECCANO

Showman's Traction Engine

(MODEL No. 10.15)

SPECIAL FEATURES

This working model of a showman's traction engine is fitted with a dummy twin-cylinder steam engine that can be set in motion by an Electric Motor. The 'engine' drives the rear traction wheels and also a dynamo at the front of the boiler. Steering of the front wheels is controlled from the driver's platform.

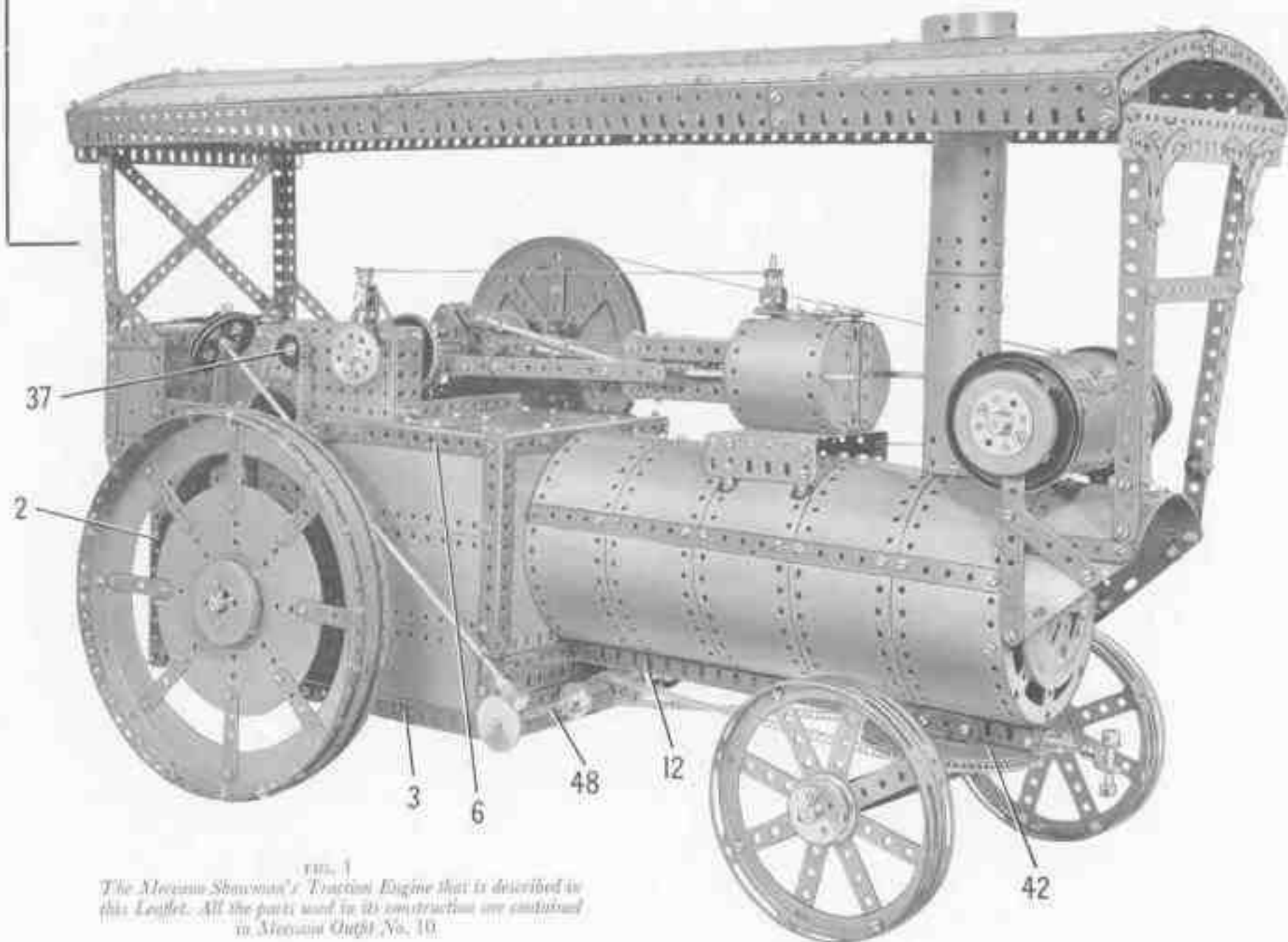

FIG. 1

The Meccano Showman's Traction Engine that is described in this Leaflet. All the parts used in its construction are contained in Meccano Outfit No. 10.

The showman's traction engine, flaunting its gay colouring and gleaming brasswork, never fails to excite attention, and it is a matter for regret that the opportunities for seeing these fine old vehicles today are in some parts of the country much more rare than once was the case. They are to be seen in some amusement grounds and at country fairs, however, where they are usually a focal point of interest for admiring and excited youngsters, and indeed for many of us who are not so young.

There seems to be something peculiarly fascinating about these powerful machines, which are really miniature power plants, for they are used not only for hauling caravans, animal cages and wagon loads of roundabout props, but also for generating the electricity for driving the amusement machines and lighting the fairgrounds and sidestows.

The electric generator is mounted on top and at the front of the long boiler, and is driven at high speed by a belt from the large and heavy flywheel of the steam engine that provides the motive power for the tractor. Those who have ever had the pleasure of seeing one of these machines in operation, will not easily forget the fascinating effect created by the whirr of the

dynamo, the swish of the belt, the hiss of escaping steam and the dazzle of the dozens of electric bulbs mounted around the tractor canopy, their brilliance reflected and enhanced by the gleaming twisted brass pillars of the canopy and the shining paintwork of the carefully polished boiler. As a background to all this would be the laughter of the crowds, the din of side-show attendants each trying to out-shout his rivals and the piercing high-pitched music of the whirling organs.

It is a traction engine of this kind that forms the basis of the fine Mercano model described in this Leaflet, and although the model does not incorporate all the minor details of the original it does follow its general design as closely as possible.

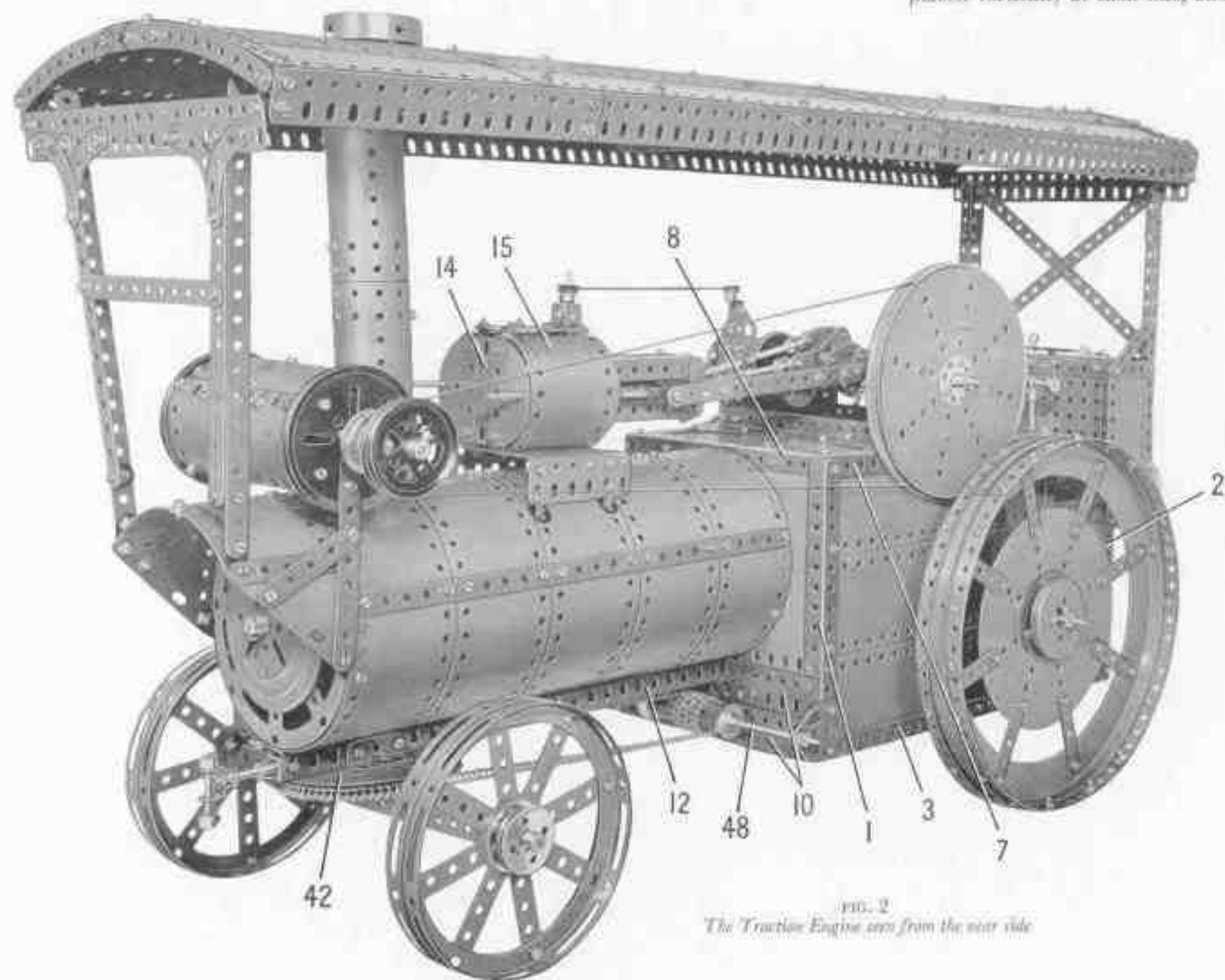

FIG. 2
The Traction Engine seen from the near side

Construction of the Body and Coal Bunker (Figs. 1, 2, 4 and 6)

Each side is assembled on a framework formed by a $7\frac{1}{2}$ " Angle Girder (1) and a made-up girder (2), connected by $12\frac{1}{2}$ " Angle Girders (3), (4) and (5) (Fig. 4). The girder (2) consists of a $5\frac{1}{2}$ " and a $4\frac{1}{2}$ " Angle Girder bolted together. A further $12\frac{1}{2}$ " Angle Girder (6) (Fig. 6) is bolted across the off-side of the model, but on the near side a $9\frac{1}{2}$ " Angle Girder (7) is used, to allow a gap at the rear for the cab entrance. The off-side is filled in by three $12\frac{1}{2}$ " x $2\frac{1}{2}$ " Strip Plates, and on the near side a $9\frac{1}{2}$ " x $2\frac{1}{2}$ " and two $12\frac{1}{2}$ " x $2\frac{1}{2}$ " Strip Plates are used.

The sides are connected together at the front by a $7\frac{1}{2}$ " Angle Girder (8) (Fig. 6), and a similar Girder (9) (Fig. 4). The front is partly filled in by a $5\frac{1}{2}$ " x $2\frac{1}{2}$ " Flexible Plate placed vertically at each side, and by two $7\frac{1}{2}$ " Flat Girders (10) (Fig. 2).

At the rear the sides are linked by a made-up girder (11) (Fig. 4), made from two $4\frac{1}{2}$ " Angle Girders overlapped three holes. The lower part of the rear of the body is filled in by three $5\frac{1}{2}$ " x $2\frac{1}{2}$ " Flat Plates arranged vertically. These Plates are extended upward by two vertical $4\frac{1}{2}$ " x $2\frac{1}{2}$ " Flat Plates and a $4\frac{1}{2}$ " x $2\frac{1}{2}$ " Flexible Plate, and they are edged at the top by two $4\frac{1}{2}$ " Angle Girders overlapped three holes. The floor of the driving compartment is made from a $5\frac{1}{2}$ " x $2\frac{1}{2}$ " and a $4\frac{1}{2}$ " x $2\frac{1}{2}$ " Flat Plate overlapped and bolted to the Girders (5).

The sides of the coal bunker are assembled as shown in Fig. 4. The back of the bunker is made from two $5\frac{1}{2}$ " x $3\frac{1}{2}$ " Flat Plates attached to the sides by Angle Brackets. The curved bottom is made from two $4\frac{1}{2}$ " x $2\frac{1}{2}$ " Flexible Plates overlapped three holes and attached to Obtuse Angle Brackets. A hinged lid is fitted as shown in Fig. 6.

The Boiler (Figs. 1 and 2)

The boiler is built up on two $12\frac{1}{2}$ " Angle Girders bolted together to form a channel section girder (12). The boiler consists of five built-up plates, each made from a $12\frac{1}{2}$ " x $2\frac{1}{2}$ " Strip Plate and a $5\frac{1}{2}$ " x $2\frac{1}{2}$ " Flexible Plate bolted end to end and curved to shape. A $12\frac{1}{2}$ " Angle Girder is fixed inside the boiler diametrically opposite to the girder (12) and two $12\frac{1}{2}$ " Strips are bolted along the sides. The front and rear ends of the boiler are Hub Discs, but before the front is fixed in place the rear Hub Disc should be bolted to the Girders (8) and (9) of the body (Figs. 2 and 4). At the front the Flanged Disc of a Ball Thrust Bearing is bolted to the Hub Disc, and a Threaded Pin is fixed in a Threaded Boss that is mounted on a $\frac{1}{8}$ " Bolt.

The Cylinder Unit (Figs. 2 and 3)

The cylinder block is assembled on a $5\frac{1}{2}$ " x $2\frac{1}{2}$ " Flanged Plate (13) (Fig. 3) fitted at each flange with

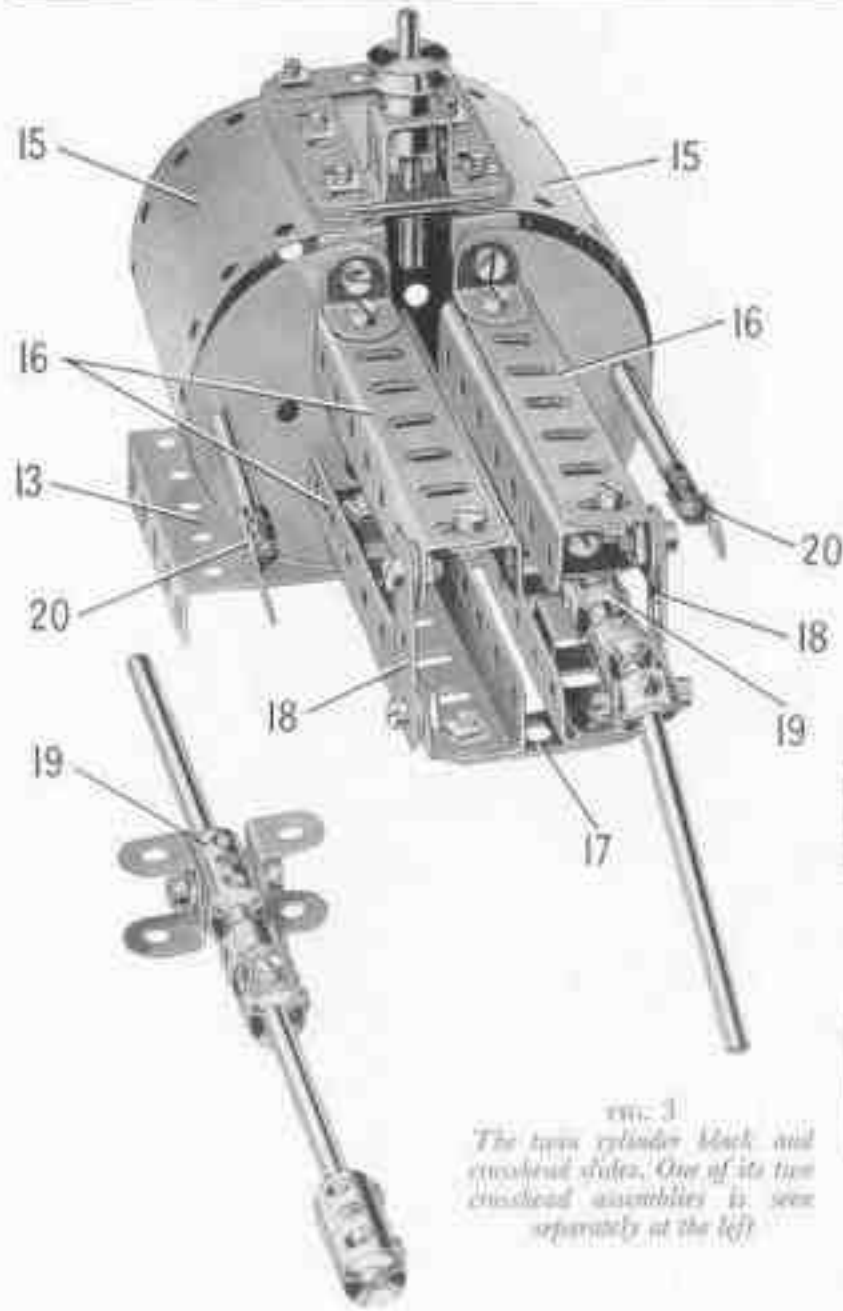

FIG. 3
The two cylinder block and crosshead slates. One of its two crosshead assemblies is seen separately at the left.

a 3" Flat Girder. The Flat Girders are attached to Obtuse Angle Brackets bolted direct to the boiler.

The front end of the cylinder block is made from a 2 1/2" x 1 1/4" Flexible Plate (14) (Fig. 2) fitted along its longer edges with Semi-Circular Plates, and the rear end is formed by two Semi-Circular Plates. The ends are joined together by four 2 1/2" x 1/4" Double Angle Strips, and a 4 1/2" x 2 1/4" Flexible Plate (15) is curved to shape and bolted to the Double Angle Strips on each side. The lower pair of Double Angle Strips is bolted to the Flanged Plate (13). The top edges of the Plates (15) are connected to the Double Angle Strips by 1/2" Bolts placed with their shanks pointing upward. The top of the cylinder block is a 2 1/2" x 1 1/4" Flexible Plate edged by 2 1/2" and 1 1/4" Strips, and is held on the shanks of these Bolts by further nuts. A Double Bent Strip is fixed to the rear end of the 2 1/2" x 1 1/4" Flexible Plate and supports a 2" Rod that forms the governor shaft. The Rod is held in place by a Collar and a 1/2" fixed Pulley.

The piston rod slide bars are made from eight 3/4" Angle Girders joined in pairs to make 3 1/2" channel girders (16). Each channel girder is then attached to an Angle Bracket bolted to the rear of the cylinder block, and the lower girders are linked across by a 1 1/2" Strip (17). The girders on each side are connected together by a 1 1/2" Strip (18) that is spaced from the girders by a Washer on each bolt.

Each piston rod is a 3" Rod, and its crosshead is formed by a Coupling (19) fitted with two Double Brackets. Each Double Bracket is fixed firmly to one of the centre tapped holes of the Coupling by a bolt, and the Double Brackets slide freely in the channels formed by the pairs of girders (16). A 1" Rod is fixed in each of the Couplings (19) and each Rod carries a Swivel Bearing.

The valve rods are 5" in length, and each is fitted with a Rod and Strip Connector (20).

The Power Unit (Figs. 4 and 7)

The model is driven by an E15R Electric Motor housed in the body. The Motor is supported by two made-up girders (21) (Fig. 4) bolted across its flanges and attached to Girders (5) on each side. The girders (21) are each made from two 5 1/2" Angle Girders. The Motor control switch is extended by a 2 1/2" Strip fitted at the top with a 1/2" Bolt that forms an operating handle.

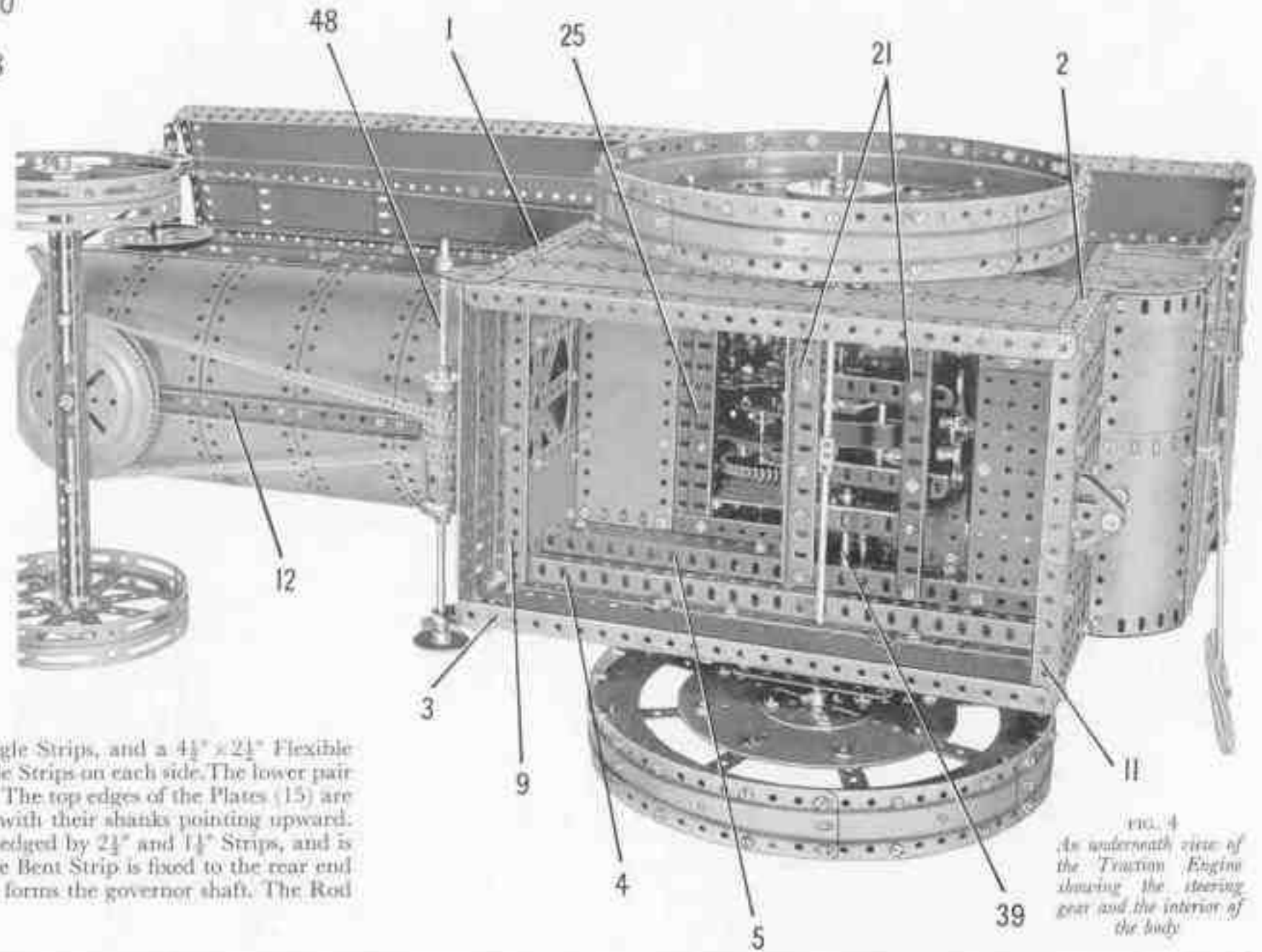
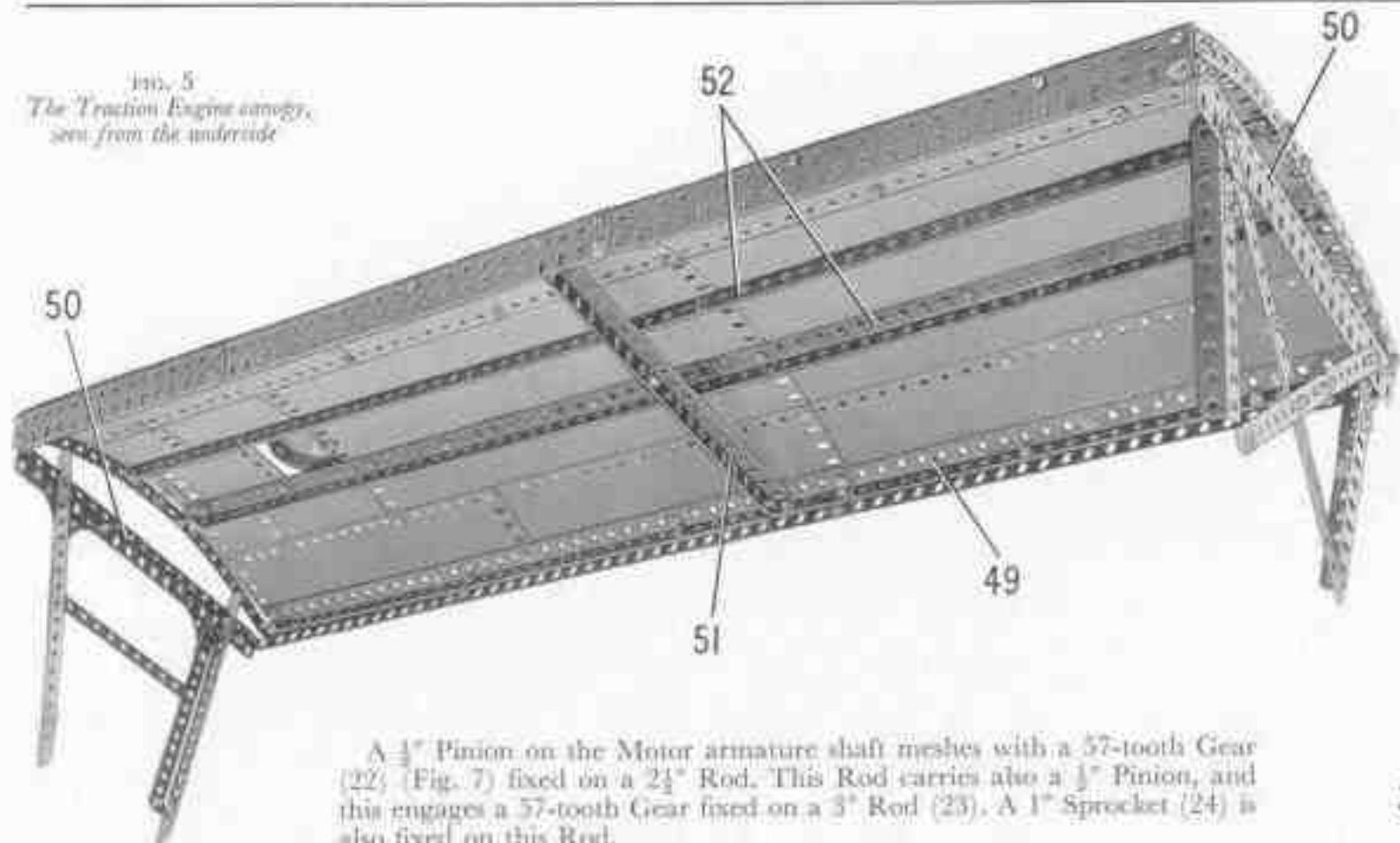

FIG. 4
An underneath view of the Traction Engine showing the steering gear and the interior of the body.

FIG. 5
The Traction Engine canopy,
seen from the underside



A $\frac{1}{2}$ " Pinion on the Motor armature shaft meshes with a 57-tooth Gear (22) (Fig. 7) fixed on a $2\frac{1}{2}$ " Rod. This Rod carries also a $\frac{1}{2}$ " Pinion, and this engages a 57-tooth Gear fixed on a 3" Rod (23). A 1" Sprocket (24) is also fixed on this Rod.

The Crankshaft and Valve Control Eccentrics (Figs. 3, 6, 7 and 8)

The crankshaft is supported in two built-up bearings, each consisting of two $3\frac{1}{2}$ " x $2\frac{1}{2}$ " Flanged Plates joined by $2\frac{1}{2}$ " Flat Girders. The bearings are fixed to made-up girders (25) (Fig. 7) and (26) (Fig. 6), each of which is made from two $5\frac{1}{2}$ " Angle Girders overlapped.

The outer crankshaft webs are each made from a Flat Trunnion fitted with a Double Arm Crank (28) and a Crank (29). The inner web is made from two Flat Trunnions bolted together at right angles, the bolts holding also the Cranks (30) (Fig. 7). The webs are held together by 1" Rods fixed in the Cranks (29) and (30), and a $1\frac{1}{2}$ " Strip bolted to an End Bearing (31) is carried on each Rod. The crank webs are fixed on a $4\frac{1}{2}$ " Rod (32) (Fig. 6) on one side and a 4" Rod (33) on the other. A Triple Throw Eccentric is fixed on each Rod, and these are linked by made-up strips to the Rod and Strip Connectors (20) (Fig. 3) on the valve rods. The End Bearings (31) (Fig. 6) are connected by made-up rods to the Swivel Bearings on the piston rods. The made-up strips are formed by $5\frac{1}{2}$ " Strips overlapped, and each made-up rod consists of a 2" and a $2\frac{1}{2}$ " Rod joined by a Coupling.

The Rod (32) carries at its outer end a flywheel made by bolting two 6" Circular Plates to a 6" Pulley. Rod (33) carries a $1\frac{1}{2}$ " Bevel Gear (34) that meshes with a $\frac{1}{2}$ " Bevel fixed on a $1\frac{1}{2}$ " Rod. This Rod is mounted in a Double Bracket attached to a Flat Trunnion bolted to the crankshaft bearing, and the Rod carries also a $\frac{1}{2}$ " fixed Pulley that is connected by a Cord belt to the Pulley on the governor shaft.

The drive from the Motor to the crankshaft is taken from Sprocket (24) (Fig. 7) by a length of Sprocket Chain to a 1" Sprocket (35). Sprocket (35) is fixed on an 8" Rod that carries also a $\frac{1}{2}$ " Sprocket (36) and a 1" Sprocket (37). Sprocket (36) is linked by Chain to a 2" Sprocket on the crankshaft.

The Drive to the Rear Axle (Figs. 7 and 8)

Sprocket (37) (Fig. 7) is connected by Chain to a 2" Sprocket fixed on a 2" Rod (38). This Rod is

FIG. 6
A plan view of the
Traction Engine showing
the general layout

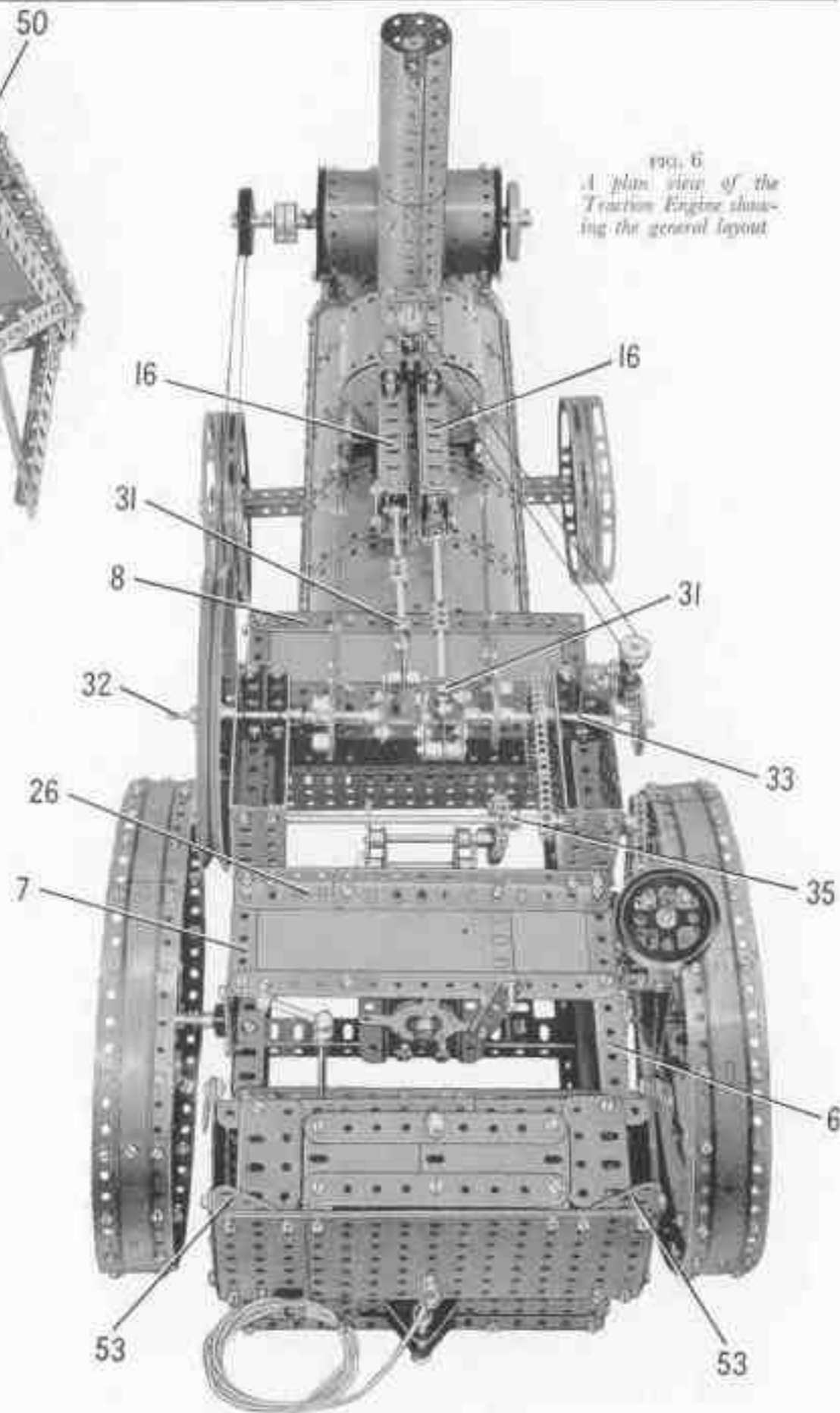

mounted in the side of the body and in a Double Bent Strip bolted inside the girder (6). The Rod is held in place by a Collar. A $\frac{1}{2}$ " Pinion is also fixed on Rod (38) and meshes with a $3\frac{1}{2}$ " Gear on a $3\frac{1}{2}$ " Rod (39), which is supported in the side of the body and in a $2\frac{1}{2}$ " Angle Girder bolted to the girders (21) (Fig. 4). Rod (39) carries between the Gear and the body, a $\frac{3}{4}$ " Sprocket, and this is linked by Chain to a 3" Sprocket on the rear axle. A cover over the gearing is provided by a $5\frac{1}{2}$ " x $3\frac{1}{2}$ " Flat Plate that is bolted to 1" Reversed Angle Brackets (40) (Fig. 6) and to Angle Brackets fixed to 1" x 1" Angle Brackets (41).

The rear axle is formed by two $6\frac{1}{2}$ " Rods joined by a Coupling. It is supported in the

sides of the body and in a Double Bent Strip bolted to the near-side. The off-side half of the axle passes through the $5\frac{1}{2}$ " x $3\frac{1}{2}$ " Flat Plate that forms the gear cover.

The Rear Wheels (Figs. 2 and 4)

The rim of each wheel is made by bolting a $2\frac{1}{2}$ " x $1\frac{1}{4}$ " and six $5\frac{1}{2}$ " x $1\frac{1}{4}$ " Flexible Plates round a Flanged Ring. The hub consists of a 6" Circular Plate bolted between two Face Plates that are fixed on the rear axle, and it is connected to the rim by eight $2\frac{1}{2}$ " Strips. A Wheel Flange bolted to a $1\frac{1}{2}$ " Sprocket is fixed on the end of the axle to complete the wheel. Driving Bands can be placed round the rim of the wheel as shown to provide it with a more even running surface.

The Front Axle and Steering Assembly (Figs. 2, 4 and 8)

The front axle is made from two $9\frac{1}{2}$ " Angle Girders bolted together and fitted at each end with two Angle Brackets spaced five holes apart. Each front wheel is fixed on a 5" Rod mounted in the pair of Angle Brackets and held in place by a Collar. Each wheel is made from a Hub Disc and a $5\frac{1}{2}$ " Circular Girder bolted together.

The complete axle is attached to the Toothed Disc of a Ball Thrust Bearing by bolts that secure also a Double Arm Crank. A $2\frac{1}{2}$ " Rod fixed in the Double Arm Crank is passed through a Bush Wheel and a 4" Circular Plate (42) (Fig. 2), which is bolted to $1\frac{1}{2}$ " Angle Girders fixed to the girder (12). The $2\frac{1}{2}$ " Rod passes inside the boiler and is held in place by a Collar.

FIG. 7
Details of the crankshaft, Motor and reduction gearing

The steering column is a made-up rod formed by two $6\frac{1}{2}$ " Rods, each of which is fitted with a Collar at one end. The Collars are gripped in a Socket Coupling (43) (Fig. 8) and the complete rod is mounted in a $2\frac{1}{2}$ " Strip (44), a 1" x 1" Angle Bracket (45), and an Oblique Angle Bracket (46). The rod carries at its lower end a Worm (47), and this meshes with a 50-tooth Gear on a made-up rod (48) (Fig. 4), consisting of two $4\frac{1}{2}$ " Rods joined by a Coupling. The rod is mounted in Flat Trunnions bolted to the body, and it carries a drum formed by two Sleeve Pieces, each of which is fitted at its inner end with a Chimney Adaptor that fits over the Coupling. A $\frac{1}{2}$ " Flanged Wheel is pressed over each end of the drum and is fixed on rod (48). An endless length of Sprocket Chain is passed several times round the drum, and round the Toothed Disc of the front wheel assembly.

The Dynamo (Figs. 1 and 2)

The dynamo seen on top of the boiler at the front, is made by bolting two $4\frac{1}{2}$ " x $\frac{1}{2}$ " Double Angle Strips between two 3" Pulleys. Washers are placed between the lugs of the Double Angle Strips and the Pulleys, to allow two $5\frac{1}{2}$ " x $2\frac{1}{2}$ " Flexible Plates and two $1\frac{1}{4}$ " radius Curved Plates to be bolted in position as shown in Figs. 1 and 2.

The dynamo is mounted on a platform that forms a cowl over the boiler smoke-box. The cowl is made from a $3\frac{1}{2}$ " x $2\frac{1}{2}$ " Flexible Plate and two $2\frac{1}{2}$ " x $2\frac{1}{2}$ " Triangular Flexible Plates curved to shape and edged by a $5\frac{1}{2}$ " and two 3" Strips. This assembly is attached to the front end

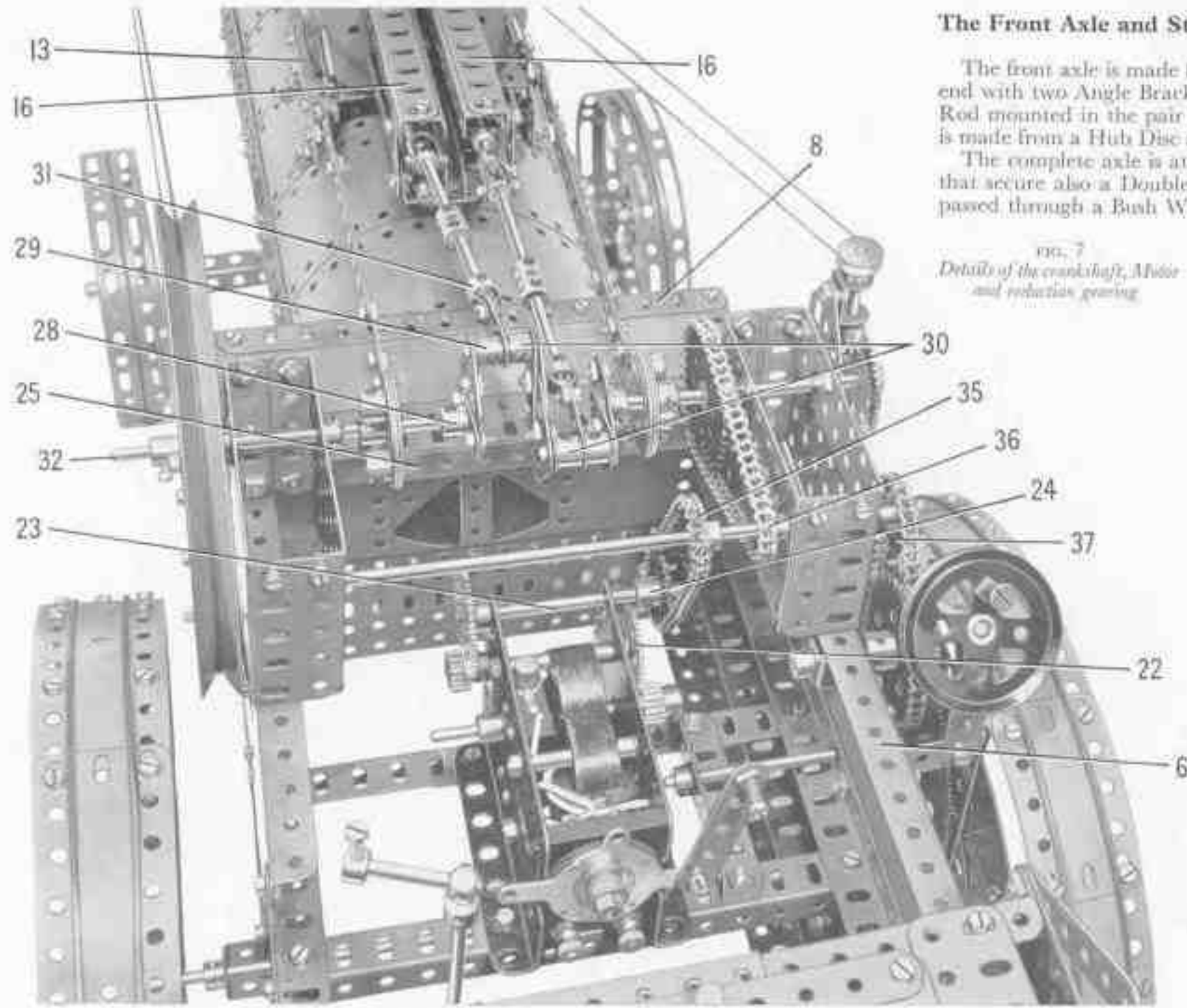

of the boiler by three Fishplates and the projecting ends of the 3" Strips. A 4½" Strip bolted to each Pulley of the dynamo is fixed to the platform and is beared by a 2½" Strip.

An 8" Rod is passed through the 3" Pulleys, and is fitted at one end with a Wheel Flange bolted to a Bush Wheel. Two 1½" Flanged Wheels are fixed in position at the opposite end, and two 2" Pulleys are held by their set screws on the Rod. A belt made from a length of Cord is passed round one of these Pulleys and the 6" Pulley of the flywheel.

Construction of the Canopy and Chimney (Figs. 1, 2 and 5)

An underneath view of the canopy is shown in Fig. 5. It is assembled on a framework, each side of which is formed by a made-up girder (49) that is attached by Angle Brackets to 9½" Flat Girders (50). The made-up girders are assembled from 18½" and 12½" Angle Girders, and they are linked at the centre by a girder (51) attached to Angle Brackets. The girder (51) is made from two 5½" Angle Girders overlapped two holes.

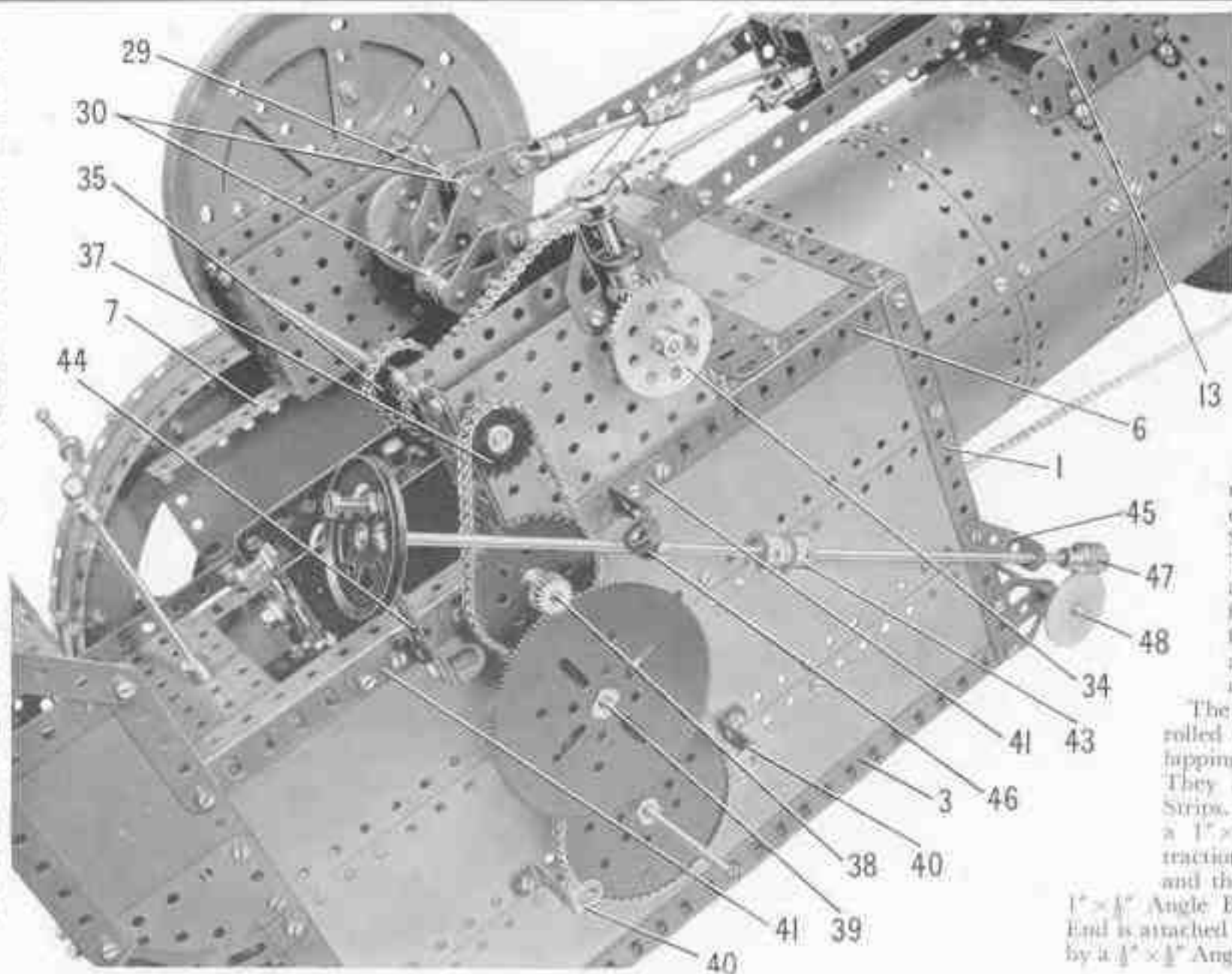

FIG. 6. The off-side of the Traction Engine with the rear wheel removed to reveal the drive to the fan shaft

Two further made-up girders (52) are attached by Angle Brackets to 5½" Curved Strips connected to the girders (49). The framework is filled in by Flexible and Strip Plates bolted to the girders (49) and (52) and attached to the Curved Strips by Angle Brackets. The arrangement of the Plates is shown in Fig. 5.

The canopy is supported at the rear by two made-up angle girders bolted to 1½" Corner brackets (53) (Fig. 6) fixed to the body. Each of these girders consists of a 4½" and a 2" Angle Girder. The front supports are made from two built-up girders each consisting of a 9½" and a 7½" Strip joined by Angle Brackets. The lower ends of these girders are attached to Obtuse Angle Brackets fixed to the boiler cowl. The front and rear canopy supports are braced as shown in Figs. 1 and 2.

The chimney is made from two Boilers rolled to a smaller diameter by overlapping their longer edges three holes. They are joined end to end by two Strips. The lower Boiler is attached to a 1" x 1" Angle Bracket fixed to the traction engine boiler behind the dynamo, and the upper Boiler is connected by a 1" x ½" Angle Bracket to the canopy. A Boiler End is attached to the canopy above the chimney by a ½" x ½" Angle Bracket.

Parts Required to Build the Meccano Showman's Traction Engine

2 of No. 1	12 of No. 9	3 of No. 13	2 of No. 23a	1 of No. 40	4 of No. 70	4 of No. 103f	7 of No. 126a	2 of No. 165	14 of No. 192
2 " " 1a	4 " " 9a	2 " " 15a	4 " " 24	2 " " 43	4 " " 89	2 " " 103g	2 " " 130	2 " " 166	3 " " 196
6 " " 1b	8 " " 9b	1 " " 15b	1 " " 24b	4 " " 43a	2 " " 89a	4 " " 103k	2 " " 133	2 " " 167b	20 " " 197
16 " " 2	1 " " 9c	2 " " 16	3 " " 26	3 " " 43c	4 " " 90a	4 " " 109	4 " " 136	1 " " 168a	2 " " 200
2 " " 2a	2 " " 9e	4 " " 16a	1 " " 27	3 " " 52a	2 " " 91	3 " " 111a	1 " " 138a	1 " " 168b	2 " " 212
4 " " 3	2 " " 9f	3 " " 16b	2 " " 27a	5 " " 53	2 " " 95	10 " " 111c	3 " " 137	1 " " 171	4 " " 214
4 " " 4	10 " " 10	5 " " 17	1 " " 27b	3 " " 53a	2 " " 95a	2 " " 114	3 " " 143	1 " " 179	2 " " 222
33 " " 5	5 " " 11	4 " " 18a	1 " " 30a	1 " " 58	1 " " 95b	1 " " 115	3 " " 146	2 " " 186d	2 " " 223
2 " " 6	36 " " 12	4 " " 18b	1 " " 30c	20 " " 59	3 " " 96	2 " " 116	1 " " 146a	2 " " 186e	
7 " " 6a	4 " " 12a	4 " " 18c	1 " " 32	4 " " 62	2 " " 96a	4 " " 118	1 " " 147b	6 " " 188	
4 " " 7a	1 " " 12b	1 " " 19c	660 " " 37a	3 " " 62b	4 " " 100a	2 " " 124	1 " " 162	12 " " 189	1 E15R
14 " " 8	7 " " 12c	4 " " 20	642 " " 37b	6 " " 63	4 " " 103b	1 " " 125	1 " " 162b	10 " " 190	Electric Motor
3 " " 8a	2 " " 13a	3 " " 20a	62 " " 38	1 " " 64	2 " " 103c	2 " " 126	2 " " 163	3 " " 190a	(not included
4 " " 8b	4 " " 14	2 " " 20b					2 " " 164	2 " " 191	in Outfit)