

# MECCANO

## Double Deck Bus

(MODEL No. 10.5)

### SPECIAL FEATURES

A two-speed and reverse gear-box, clutch, differential, brakes and steering mechanism, are included in the chassis details of this fine model Double Deck Bus. It is driven by a Meccano E15R Electric Motor.

The model Double Deck Bus illustrated and described in this Leaflet is based on a rear-entry vehicle of the four wheel type, and is designed specially for construction from Meccano Outfit No. 10. It is driven by a Meccano E15R or E20R Electric Motor coupled to a two-speed and reverse gear-box through a neat friction clutch. Other chassis details include a working differential, rear wheel brakes, sprung axles and steering gear.

Construction of the model is simplified by the fact that the chassis and body are designed as separate complete units. It is best to start construction with the chassis, details of which follow.

#### Details of the Chassis (Fig. 2)

The centre section of the chassis consists of two channel girders, each of which is formed by two built-up girders joined together by Flat Girders. Each built-up girder is made from a  $1\frac{1}{2}$ " Angle Girder and a  $\frac{3}{4}$ " Angle Girder overlapped three holes, and they are connected by a  $1\frac{1}{2}$ " and a  $\frac{3}{4}$ " Flat Girder.

The upswep section of the chassis over the rear axle is made by bolting 4" Stepped Curved Strips to the rear ends of the channel girders. Each Curved Strip is extended by a 3" Stepped Curved Strip overlapped two holes, and this is further extended by another 4" Stepped Curved Strip, which also is overlapped two holes. A  $\frac{3}{4}$ " Strip, a Fortified Slotted Strip and a  $\frac{1}{2}$ " Strip are bolted together and are fixed to a Double Bracket held by a bolt (1) and Angle Brackets attached to the Curved Strips. The  $\frac{3}{4}$ " Strip overlaps the end of the channel girder by two holes.

At the front on each side a 3" Strip is arranged to overlap the channel girder by two holes, and it is bolted at a slight angle so that this part of the chassis sweeps upward over the front axle. The 3" Strip is extended forward by a  $5\frac{1}{2}$ " Curved Strip. A strip (2) made from a  $3\frac{1}{2}$ " and a  $3\frac{1}{2}$ " Strip, is bolted to the channel girder, and is connected to the  $5\frac{1}{2}$ " Curved Strip by an Angle Bracket.

The two side-members of the chassis are connected at the front by a  $5\frac{1}{2}$ " Strip (3), and by a similar strip at the rear. A  $5\frac{1}{2}$ " Angle Girder (4) is bolted across the chassis and is strengthened by 1" Corner Brackets. Two  $1\frac{1}{2}$ " Corner Brackets (5) are fixed to this Girder. The cross-member (6) consists of a  $5\frac{1}{2}$ " Angle Girder and two  $2\frac{1}{2}$ " Angle Girders. The  $2\frac{1}{2}$ " Girders are connected at the centre by two  $2\frac{1}{2}$ " Strips placed face to face. A  $9\frac{1}{2}$ " Angle Girder (7) is bolted across the chassis as shown, and a  $2\frac{1}{2}$ " Angle Girder (8) is fixed to each side and braced by a vertical  $1\frac{1}{2}$ " Angle Girder.

#### The Rear Axle (Fig. 4)

The axle casing is in two sections, one of which consists of two  $2\frac{1}{2}$ "  $\times$   $\frac{1}{2}$ " Double Angle Strips bolted between a Boiler End and a Face Plate. In the other section  $1\frac{1}{2}$ "  $\times$   $\frac{1}{2}$ " Double Angle Strips are used in place of the  $2\frac{1}{2}$ "  $\times$   $\frac{1}{2}$ " Double Angle Strips. When the differential is assembled the sections are joined together by bolting four 2" Strips between the Boiler Ends. One of the 2"

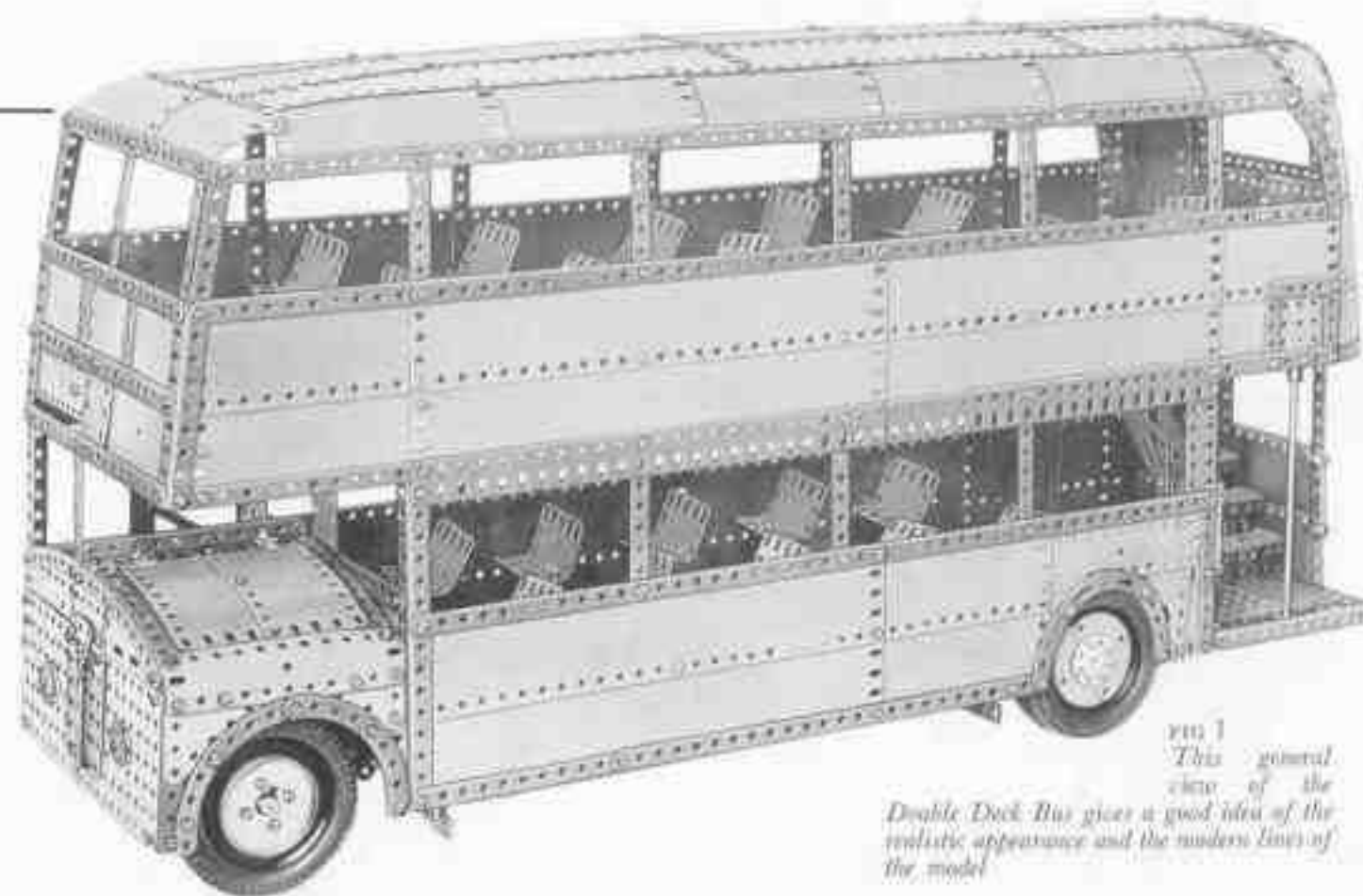

Strips is attached by  $\frac{1}{2}$ " Bolts and is spaced from the Boiler Ends by three Washers on each side. A Double Bear Strip is attached to this 2" Strip, and a  $1\frac{1}{2}$ " Rod, fitted with a  $\frac{1}{2}$ " Pinion (9), is mounted in these parts.

A 5" Rod is mounted in the longer section of the axle casing and on it a  $\frac{1}{2}$ " Contrate (10) is freely mounted. A  $\frac{1}{2}$ " Contrate (11) is fixed on the Rod, which is then passed into the longitudinal hole of a Coupling (12). Two 1" Screwed Rods are fixed in the Contrate (10) by two nuts each, and a  $1\frac{1}{2}$ " Rod is fixed in the Coupling (12) and in Collars screwed on to the Screwed Rods. Two  $\frac{1}{2}$ " Pinions are mounted freely on Pivot Bolts, which are screwed into the Coupling (12). A  $3\frac{1}{2}$ " Rod is passed through the short section of the axle casing and is fitted with a  $\frac{1}{2}$ " Contrate. This Contrate and the Contrate (11) engage the teeth of the  $\frac{1}{2}$ " Pinions. The Contrate (10) is spaced from the axle casing by Washers so that it meshes with the Pinion (9).

The inner wheel of each set of twin rear wheels has a Wheel Flange bolted to it, and the outer wheel of each set is fitted with two Semi-Circular Plates and a Wheel Disc. The Wheel Flange

forms the brake drum. The brake is made by fixing a Fishplate (13) on a  $\frac{1}{2}$ " Bolt by means of a nut. Two Washers are placed on the Bolt, which is then passed through one of the Face Plates of the rear axle. A Fishplate (14), with a Washer on each side of it, is fixed on the Bolt by two nuts to form the brake shoe.

The rear axle is bolted to leaf-springs, each of which consists of a  $7\frac{1}{2}$ ", a  $4\frac{1}{2}$ ", a  $3\frac{1}{2}$ ", a  $2\frac{1}{2}$ " and a  $1\frac{1}{2}$ " Strip. An Angle Bracket is bolted to each end of the  $7\frac{1}{2}$ " Strip and one of them is lock-waluted to the inner lug of the Double Bracket held by the bolt (1). The other Angle Bracket is lock-waluted to a Fishplate, which is itself lock-waluted to an Angle Bracket bolted to the lower flange of the side-member channel girder.

#### Engine Unit and Clutch (Figs. 2, 3 and 6)

One side of the engine unit consists of two  $4\frac{1}{2}$ " x  $2\frac{1}{2}$ " Flat Plates overlapped lengthways three holes and bolted to a  $3\frac{1}{2}$ " Angle Girder (15) (Fig. 6). An E15R Electric Motor is bolted to this

on a  $6\frac{1}{2}$ " Rod (19) mounted in  $1\frac{1}{2}$ " Flat Girders bolted to the front and rear of the engine unit, and is retained in place by Collars.

The clutch shaft is a  $3\frac{1}{2}$ " Rod mounted in the Double Angle Strip (18) and in the Strip (17). A Bush Wheel is fixed on the Rod, and next to it is placed a 1" loose Pulley fitted with a 1" Motor Tyre. A 37-tooth Gear is held in a Socket Coupling (20) and this assembly is free to turn on the Rod, but is pressed against the Motor Tyre by a Compression Spring, which is placed between the Socket Coupling and a Collar. A second Collar prevents the 37" Rod from sliding in its bearings. The 57-tooth Gear is driven by a  $\frac{1}{2}$ " Pinion fixed on the end of Rod (19).

The pedal (21) (Fig. 3) for operating the clutch is made by bolting an Angle Bracket to a Double Arm Crank, which pivots on a  $\frac{1}{2}$ " Bolt fixed to the side of the engine unit by two nuts. A built-up strip, made from two 3" Strips overlapped three holes, is lock-waluted to the lower arm of the clutch pedal and is lock-waluted also to another Double Arm Crank on a  $3\frac{1}{2}$ " Rod (22). This Rod is mounted in the  $2\frac{1}{2}$ " Flat Girders of the unit, and is located in their slotted holes by Fishplates bolted to the Flat Girders. Two Double Arm Cranks, each fitted with a Threaded

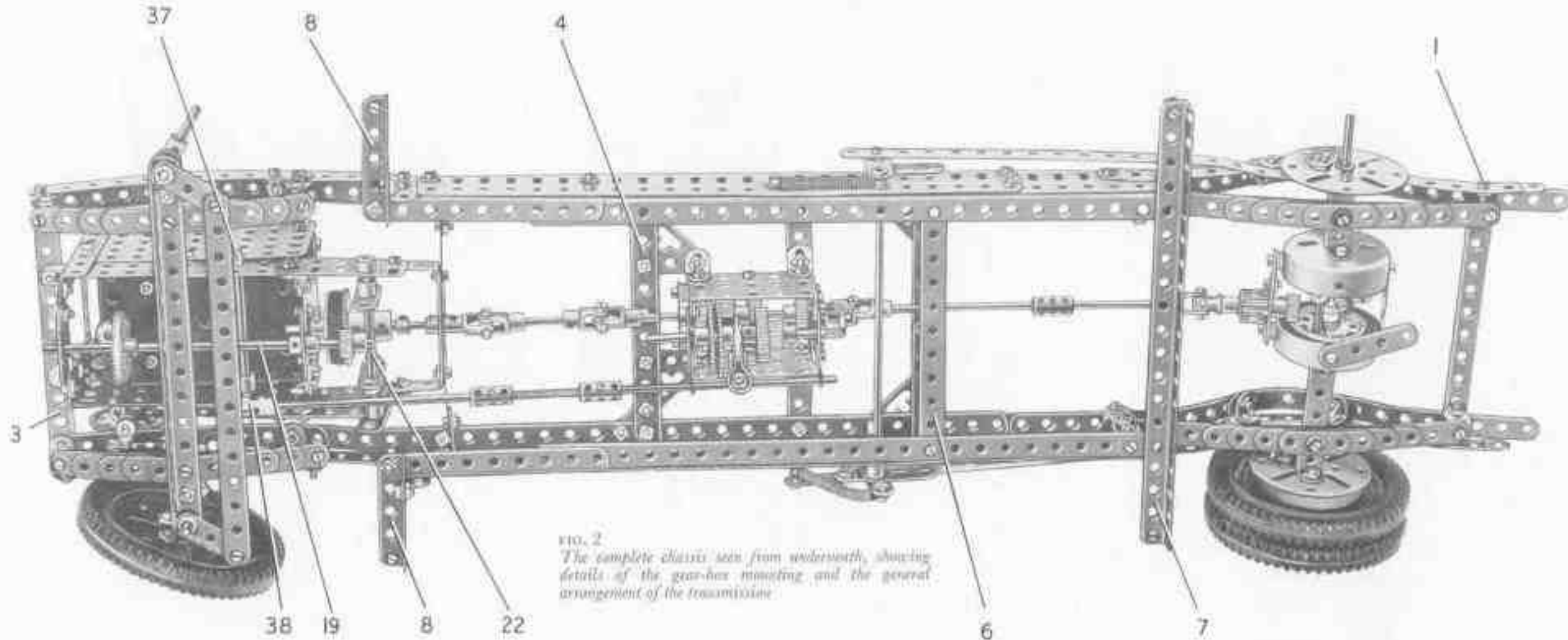

FIG. 2  
The complete chassis seen from underneath, showing details of the gear-box mounting and the general arrangement of the transmission.

side of the unit. The other side is a  $4\frac{1}{2}$ " x  $2\frac{1}{2}$ " Flat Plate fitted at each end with a 3" Angle Girder (16). A  $4\frac{1}{2}$ " Angle Girder is bolted to the top ends of the Girders (16).

The sides are connected at the front by two  $2\frac{1}{2}$ " Strips bolted to the Angle Girders, and at the rear are joined by a  $2\frac{1}{2}$ " Strip fixed to the Girder (16) of one side and attached to the other side by an Angle Bracket. Two  $2\frac{1}{2}$ " Strips, the upper one indicated at (17) (Fig. 3) are fixed also to the Girder (16), and are attached to the opposite side by Angle Brackets. A  $2\frac{1}{2}$ " Flat Girder is bolted to each side of the unit, and these are connected by a  $2\frac{1}{2}$ " x  $1\frac{1}{2}$ " Double Angle Strip (18), which is strengthened by a  $2\frac{1}{2}$ " Stepped Curved Strip.

A  $\frac{1}{2}$ " Pinion on the Motor armature shaft drives a 60-tooth Gear on a 3" Rod supported in the Motor side-plates. The Rod is held in position by a Collar, and it carries at its lower end a  $\frac{1}{2}$ " Pinion that is spaced from the Motor by three Washers. The Pinion engages a  $1\frac{1}{2}$ " Contra-

Pin, are fixed on the Rod (22) between the Flat Girders. The Threaded Pin engage the groove of the Socket Coupling (20).

The engine unit is held in the chassis by Angle Brackets bolted to its front and to the Strip (3). A  $4\frac{1}{2}$ " Strip is fixed to the Double Angle Strip (18) and is connected to the chassis by two  $1\frac{1}{2}$ " x  $1\frac{1}{2}$ " Angle Brackets.

#### Details of the Gear-box (Figs. 3 and 5)

The gear-box is shown separately in Fig. 5. The housing consists of two  $2\frac{1}{2}$ " x  $1\frac{1}{2}$ " Flanged Plates connected by a  $1\frac{1}{2}$ " x  $\frac{1}{2}$ " Double Angle Strip (23) and joined at each end by two  $1\frac{1}{2}$ " Strips. One of these Strips, indicated at (24) (Fig. 5), is spaced from the Flanged Plates by three Washers on each of the  $\frac{1}{2}$ " Bolts that holds it in position.



The input shaft is a 2" Rod fitted with a  $\frac{1}{2}$ " Pinion (25) and a  $\frac{1}{2}$ " Pinion (26), and is mounted in the Strip (24). The output shaft, which also is 2" long and is supported as shown, carries a  $\frac{1}{2}$ " Pinion (27) and a 1" Gear (28). The output shaft projects slightly beyond the Double Angle Strip (25) into the bore of the Pinion (26) in order to support the inner end of the input shaft.

The layshaft is a  $\frac{3}{4}$ " Rod that carries a 53-tooth Gear (29), a 57-tooth Gear (30), a 1" Gear (31) and a  $\frac{1}{2}$ " Pinion (32). The Rod is free to slide in its bearings, but its movement is controlled by a selector formed by

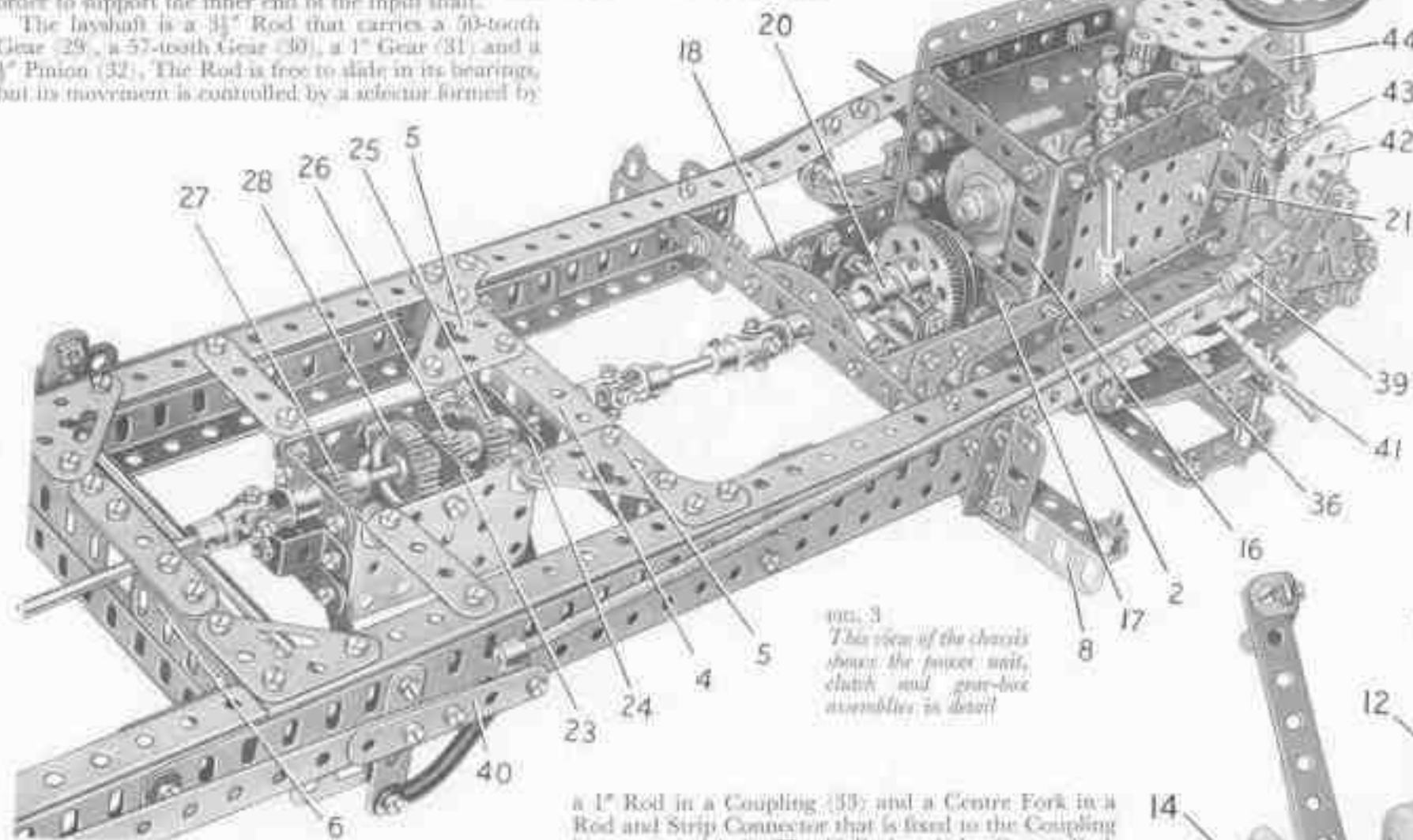

FIG. 3  
This view of the chassis shows the power unit, clutch and gear-box assemblies in detail.

a 1" Rod in a Coupling (33) and a Centre Fork in a Rod and Strip Connector that is fixed to the Coupling by a nut and bolt. The 1" Rod and the Centre Fork engage one on each side of the layshaft between the Gears (30) and (31). The Coupling is fixed on a  $\frac{1}{2}$ " Rod (34) supported in Fishplates bolted to the gear-box housing.

A  $\frac{1}{2}$ " Pinion (35) is free to turn on a  $\frac{1}{2}$ " Bolt, but is held on it by two nuts screwed against each collar. The Bolt is fixed by two nuts to the centre section of a Double Bent Strip bolted across the end of the housing.

Reverse gear is obtained when the Pinion (26) is in mesh with the Gear (30), and the Pinions (27), (32) and (35) are engaged. To arrange this the layshaft must be at the extreme left (Fig. 5). By moving the layshaft slightly to the right the Gears (28) and (31) are engaged while the Pinion (26) is still in mesh with the Gear (30). This provides low forward gear. When the layshaft is moved as far as possible to the right, the Pinion (25) and the Gear (29) are brought into mesh, with the Gears (28) and (31) still engaged, and top gear is obtained.

The gear-box is attached by Angle Brackets to 2" Strips bolted to the chassis, and is supported also by Angle Brackets fixed to the Corner Brackets (5). The input shaft is connected to the clutch shaft by a  $\frac{1}{2}$ " Rod and two Universal Couplings. The output shaft is connected to the rear axle driving-shaft by a 2 $\frac{1}{2}$ " Rod and a  $\frac{3}{4}$ " Rod joined by a Coupling, and by two made-up universal couplings, each of which consists of a Swivel Bearing and a small Fork Piece.

The gear selector lever is fixed at its lower end in a Rod Socket (36) (Fig. 3). The shank of the Rod Socket is screwed tightly into a Collar on a  $\frac{3}{4}$ " Rod (37) (Fig. 2), which is mounted in the engine unit and carries a Crank. A Strip Coupling (38) is pivotally attached to the Crank by a  $\frac{1}{2}$ " Bolt, and is connected to the Rod (34) by a  $\frac{1}{2}$ " Rod, two Couplings and a Flexible Coupling Unit.

The top end of the gear-selector lever carries two Collars located between a 2 $\frac{1}{2}$ " Stepped Curved Strip and a 2 $\frac{1}{2}$ " Strip. The Stepped Curved Strip is fixed, by two nuts on each of two  $\frac{1}{2}$ " Bolts, to Angle Brackets attached to the engine unit. The 2 $\frac{1}{2}$ " Strip is pressed against the Collars on the gear lever by a Compression Spring placed between the 2 $\frac{1}{2}$ " Strip and the head of each  $\frac{1}{2}$ " Bolt.

#### The Brake Operating Mechanism (Fig. 2, 3 and 6)

The brake pedal is made by bolting an Angle Bracket to a Crank pivoted on a  $\frac{1}{2}$ " Bolt attached to the chassis by two nuts (see Figs. 3 and 6). A Threaded Coupling (39) is locked by two nuts on a  $\frac{1}{2}$ " Bolt passed freely through the Crank, and an 11 $\frac{1}{2}$ " Screwed Rod is fixed in the Threaded Coupling by a nut. A Collar is fixed on the rear end of the Screwed Rod by a 2" Bolt, which is passed through the end hole of a built-up strip (40). This strip consists of a 9 $\frac{1}{2}$ " and a 2 $\frac{1}{2}$ " Strip overlapped three holes, and its rear end is lock-nutted to a  $\frac{1}{2}$ " Bolt passed through the Fishplate (13) (Fig. 6) of one of the brakes.

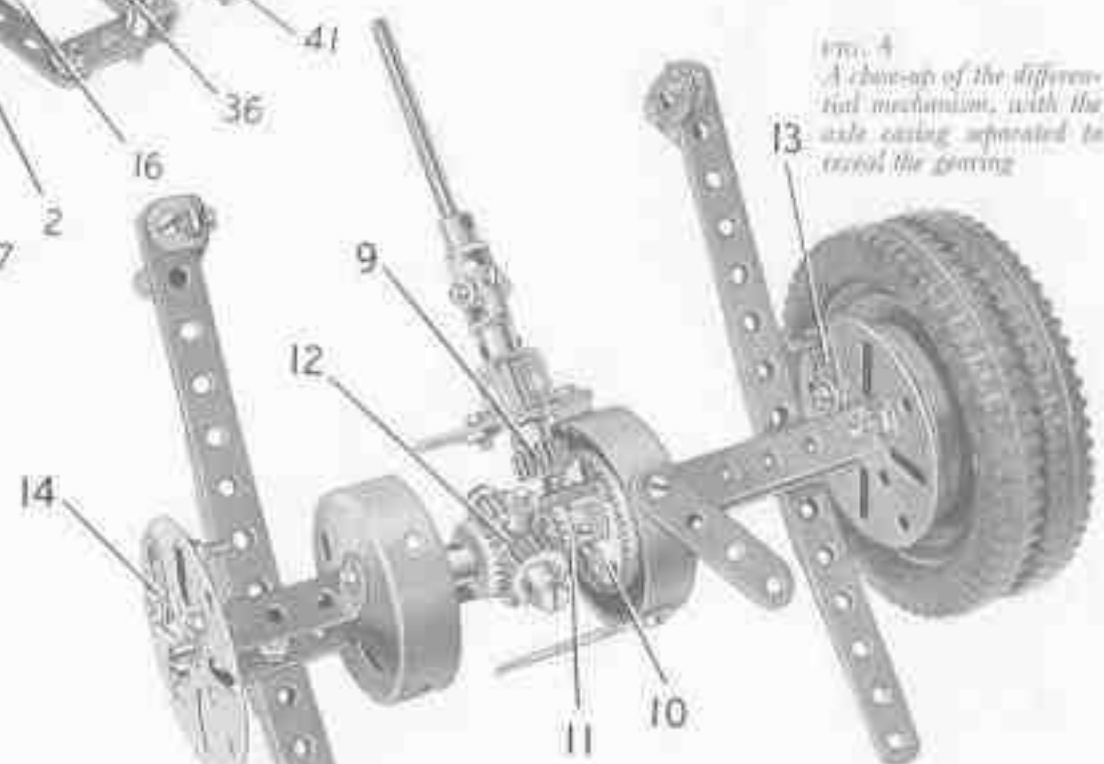
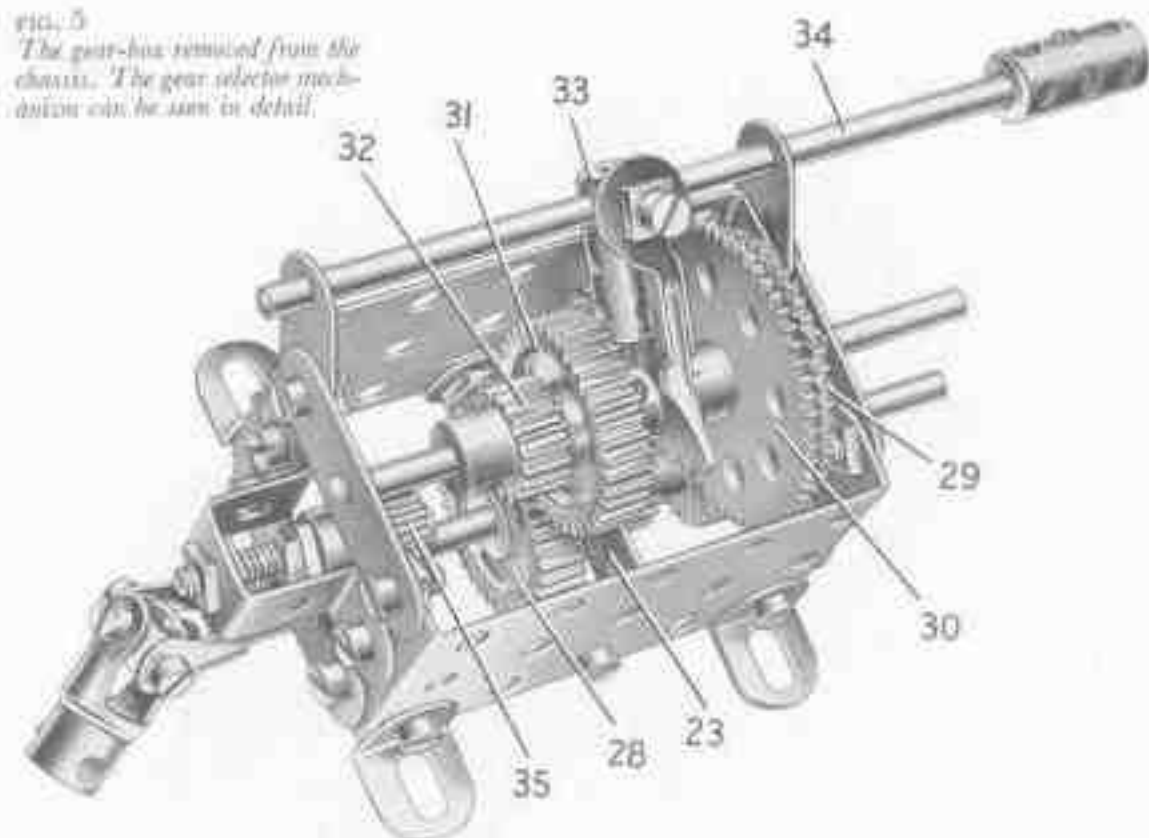

FIG. 4  
A close-up of the differential mechanism, with the axle casing separated to reveal the gearing.

The strip (40) is pivotally connected to one arm of a Bell Crank (Fig. 3) by a lock-nutted  $\frac{1}{2}$ " Bolt, and a 2" Strip is also bolted to this arm. A Spring is fitted between the lower end of the 2" Strip and the  $\frac{1}{2}$ " Bolt in the Collar at the end of the 11 $\frac{1}{2}$ " Screwed Rod. The Bell Crank is fixed on one end of a  $\frac{1}{2}$ " Rod mounted across the chassis, and another Bell Crank is secured to the other end of the Rod. A 2" Strip is bolted to the second Bell Crank and a Spring is fitted between the lower end of this Strip and the chassis. A 9 $\frac{1}{2}$ " Strip is lock-nutted to the Bell Crank and to the Fishplate (13) of one of the brakes, in the same way as the strip (40).

FIG. 5

The gear-box removed from the chassis. The gear-selector mechanism can be seen in detail.



#### Front Axle and Steering (Figs. 2, 3 and 6)

The front axle beam is a  $7\frac{1}{2}$ " Angle Girder (Fig. 2) and is attached to two leaf-springs, each of which consists of a  $5\frac{1}{2}$ ", a  $4\frac{1}{2}$ ", a  $3\frac{1}{2}$ ", a  $2\frac{1}{2}$ " and a  $1\frac{1}{2}$ " Strips. An Angle Bracket is fixed to each end of each spring, and these are *lock-nutted* to Fishplates bolted to the chassis. A  $\frac{1}{2}$ " Reversed Angle Bracket is fixed to each end of the axle beam.

Each front wheel is freely mounted on a 1" Rod fixed in a Coupling (41) (Figs. 3 and 6). The wheels are held on the Rods by Collars. The Couplings (41) are fixed on 2" Rods supported in the ends of the axle beam and in the  $\frac{1}{2}$ " Reversed Angle Brackets. Cranks fitted to the lower ends of the 2" Rods are connected by a  $7\frac{1}{2}$ " Strip pivoted on *lock-nutted* bolts.

A  $1\frac{1}{2}$ " Bevel (42) is fixed on a 2" Rod, and a Coupling is freely mounted between this Bevel and a Collar (43). The 2" Rod is supported in one side of the engine unit and in the top holes of a 2" Strip, and a 2" Slotted Strip, each of which is attached to the chassis as shown (Fig. 6). The steering column is a  $3\frac{1}{2}$ " Rod free to turn in the Coupling on the 2" Rod, and it carries a  $\frac{1}{2}$ " Bevel that engages the Bevel (42). The steering column is supported by a  $1" \times 1"$  Angle Bracket (44), bolted to a 1" Corner Bracket attached to the engine unit by two Angle Brackets.

A Rod Socket is screwed into the Collar (43) and is fixed in place by a nut. A 2" Rod in the Rod Socket carries at its lower end one half of a Dog Clutch (45), and to this a Rod and Strip Connector is pivotally attached by a nut and bolt. The Rod and Strip Connector is joined by a  $1\frac{1}{2}$ " Rod to a similar part pivoted on a bolt screwed into a Collar on a  $1\frac{1}{2}$ " Rod (46). Rod (46) is fixed in one of the Couplings (41) (Fig. 6).

#### The Lower Saloon (Figs. 8 and 9)

The side seen in Fig. 8 consists of two  $12\frac{1}{2}" \times 2\frac{1}{2}"$  Strip Plates and four  $5\frac{1}{2}" \times 2\frac{1}{2}"$  Flexible Plates, with a  $5\frac{1}{2}" \times 1\frac{1}{2}"$  Flexible Plate and a  $3\frac{1}{2}" \times 2"$  and a  $2\frac{1}{2}" \times 1\frac{1}{2}"$  Triangular Flexible Plate over the rear wheel arch. The Plates are fixed to a  $7\frac{1}{2}"$  Angle Girder (47) at the front, and are edged along the top by two  $12\frac{1}{2}"$  Strips and a  $5\frac{1}{2}"$  Strip. The lower edges are strengthened by a  $12\frac{1}{2}"$  Strip, a  $5\frac{1}{2}"$  Strip and a  $3\frac{1}{2}"$  Angle Girder (48), with a  $12\frac{1}{2}"$  and a  $5\frac{1}{2}"$  Angle Girder bolted to the inside (Fig. 7). A  $9\frac{1}{2}"$  Angle Girder (49) is fixed vertically to the side, and to it are bolted a  $4\frac{1}{2}" \times 2\frac{1}{2}"$  Flexible Plate and a  $3\frac{1}{2}"$  Flat Girder. The window divisions are  $12\frac{1}{2}"$  Strips, each of which overlaps the side by four holes. These Strips are connected by three  $9\frac{1}{2}"$  Flat Girders. A  $2\frac{1}{2}"$  Angle Girder is bolted along the top row of holes in the Flat Girders, on the inside, starting at the Girder (49) so that it overhangs the Girder (47) by three holes.

The main section of the side seen in Fig. 1 is similar to the one already described, but it is shorter and ends at the Girder (49); also a  $2\frac{1}{2}" \times 2"$  Triangular Flexible Plate is used instead of a  $2\frac{1}{2}" \times 1\frac{1}{2}"$  Triangular Flexible Plate over the wheel arch. The window divisions are connected by two  $12\frac{1}{2}"$  Flat Girders overlapped four holes.

The sides are connected at the front by two  $5\frac{1}{2}" \times 3\frac{1}{2}"$  Flat Plates overlapped three holes and edged at the top by a  $9\frac{1}{2}"$  Strip. The Flat Plates are fixed to the Girders (47), and a  $9\frac{1}{2}"$  Angle Girder (50) is bolted between their top ends. A vertical  $5\frac{1}{2}" \times 1\frac{1}{2}"$  Flexible Plate is attached to the centre of the Girder (50) and to the Flat Plates. At the rear the sides are connected by  $9\frac{1}{2}"$  Angle Girders (51) and (52) (Fig. 7), bolted to the Girders (49).

The centre gangway consists of two  $18\frac{1}{2}"$  Angle Girders connected by a  $12\frac{1}{2}" \times 2\frac{1}{2}"$  Strip Plate and a  $3\frac{1}{2}" \times 2\frac{1}{2}"$  Flexible Plate. At the front the gangway is supported by a  $2\frac{1}{2}"$  Angle Girder bolted to the  $5\frac{1}{2}" \times 3\frac{1}{2}"$  Flat Plates, and at the rear it is extended by a  $5\frac{1}{2}" \times 2\frac{1}{2}"$  Flat Plate fixed to the Girder (51). The seats are made from Flexible and Curved Plates shaped as shown and supported by  $1" \times 1"$  Angle Brackets,  $1" \times \frac{1}{2}"$  Angle Brackets and 1" Reversed Angle Brackets fixed to the gangway.

#### The Upper Saloon

The side seen in Fig. 8 consists of two  $5\frac{1}{2}" \times 2\frac{1}{2}"$  Flexible Plates, four  $12\frac{1}{2}" \times 2\frac{1}{2}"$  Strip Plates and two  $4\frac{1}{2}" \times 2\frac{1}{2}"$  Flexible Plates. These are fixed to the vertical  $12\frac{1}{2}"$  Strips that form the window divisions. At the front a  $4\frac{1}{2}"$  Angle Girder (53) is connected to the top edge of the lower saloon by a  $7\frac{1}{2}"$  Strip. The top edges of the Plates are strengthened by two  $12\frac{1}{2}"$  Strips and two  $5\frac{1}{2}"$  Strips. A built-up strip (54), made from three  $12\frac{1}{2}"$  Strips, is bolted to the top ends of the window divisions. In addition to the vertical  $12\frac{1}{2}"$  Strips, two  $5\frac{1}{2}"$  Strips, a 4" Curved Strip and a  $3\frac{1}{2}"$  Strip at the front, are used to form the windows of the upper saloon.

The other side, which is seen in Fig. 1, is similar in general arrangement to the one already described, but it varies in slight details. The top edges of the Plates are strengthened by two  $12\frac{1}{2}"$  Strips, a  $5\frac{1}{2}"$  Strip and a 3" Strip, and the lower  $4\frac{1}{2}" \times 2\frac{1}{2}"$  Flexible Plate at the rear is replaced by a  $2\frac{1}{2}" \times 3\frac{1}{2}"$  Flexible Plate and a  $2\frac{1}{2}" \times 2\frac{1}{2}"$  Flat Plate. The Flat Plate is edged by  $2\frac{1}{2}"$  Strips, but is spaced from them by nuts on the bolts to represent a recessed destination indicator.

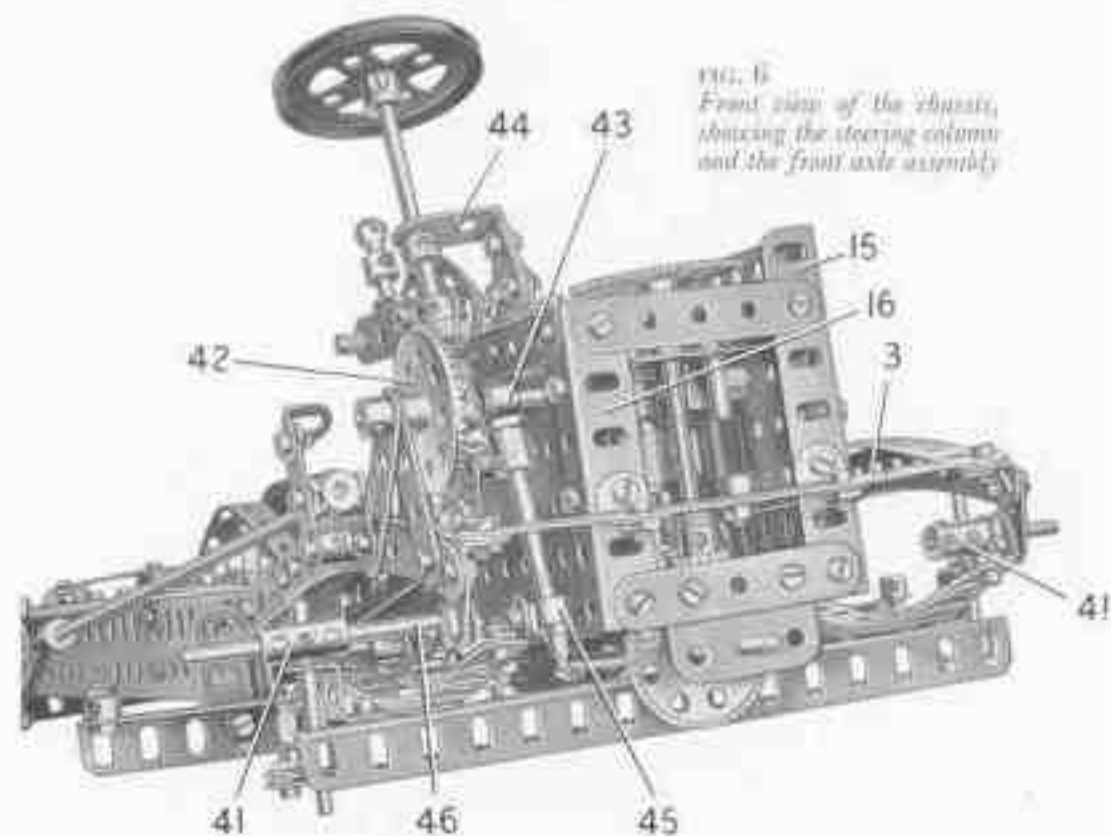

FIG. 6

Front view of the chassis, showing the steering column and the front axle assembly.



At the front of the bus the Girders (53) are connected by two  $9\frac{1}{2}$ " Strips and a built-up strip made from two  $5\frac{1}{2}$ " Strips overlapped three holes (Fig. 8). The front is plated by three  $3\frac{1}{2}$ " x  $2\frac{1}{2}$ " Flexible Plates at the top, with one half of a Hinged Flat Plate (55), a  $2\frac{1}{2}$ " x  $1\frac{1}{2}$ " Flexible Plate and a  $5\frac{1}{2}$ " x  $1\frac{1}{2}$ " Flexible Plate (56) below them. The Plate (56) is extended upward by another  $5\frac{1}{2}$ " x  $1\frac{1}{2}$ " Flexible Plate, and this is recessed from the  $3\frac{1}{2}$ " x  $2\frac{1}{2}$ " Flexible Plates by nuts on the bolts that fix them together. The front ends of the strips (54) are connected by Angle Brackets to two  $5\frac{1}{2}$ " Strips overlapped three holes.

A  $5\frac{1}{2}$ " x  $2\frac{1}{2}$ " Flanged Plate (57) (Fig. 7) is bolted to each side, and these are connected by a  $5\frac{1}{2}$ " x  $3\frac{1}{2}$ " Flat Plate and a  $5\frac{1}{2}$ " x  $2\frac{1}{2}$ " Flat Plate. At the rear a  $9\frac{1}{2}$ " Flat Girder (58) is bolted between the top ends of the Girders (49) and a  $5\frac{1}{2}$ " x  $2\frac{1}{2}$ " Flanged Plate is fixed between this Flat Girder and the rear panelling. Two  $4\frac{1}{2}$ " x  $2\frac{1}{2}$ " Flexible Plates secured to the Flanged Plate provide a cover over the boarding platform. A  $4\frac{1}{2}$ " Angle Girder is fixed to the centre of the Flat Girder (58).

The centre gangway consists of two  $2\frac{1}{2}$ " Angle Girders connected by two  $12\frac{1}{2}$ " x  $2\frac{1}{2}$ " Strip Plates. It is bolted to the Flat Plates that are fastened to the Flanged Plates (57), and to the Flanged Plate secured to the Flat Girder (58). The seats are made in the same way as those in the lower saloon, and they are supported by  $1\frac{1}{2}$ " x  $1\frac{1}{2}$ " Angle Brackets and  $2\frac{1}{2}$ " x  $1\frac{1}{2}$ ",  $2\frac{1}{2}$ " x  $1\frac{1}{2}$ " and  $3\frac{1}{2}$ " x  $1\frac{1}{2}$ " Double Angle Strips.

**Rear Panelling and Boarding Platform (Figs. 7, 8 and 10)**

The side of the lower saloon seen in Fig. 8 is extended at the rear by three curved  $5\frac{1}{2}$ " x  $2\frac{1}{2}$ " Flexible Plates, the lower one edged by a Formed Slotted Strip at the bottom, and by a curved  $5\frac{1}{2}$ " Strip along its top edge. The lower edge of the top Plate is covered by a curved  $5\frac{1}{2}$ " Flat Girder. The lower rear panelling consists of

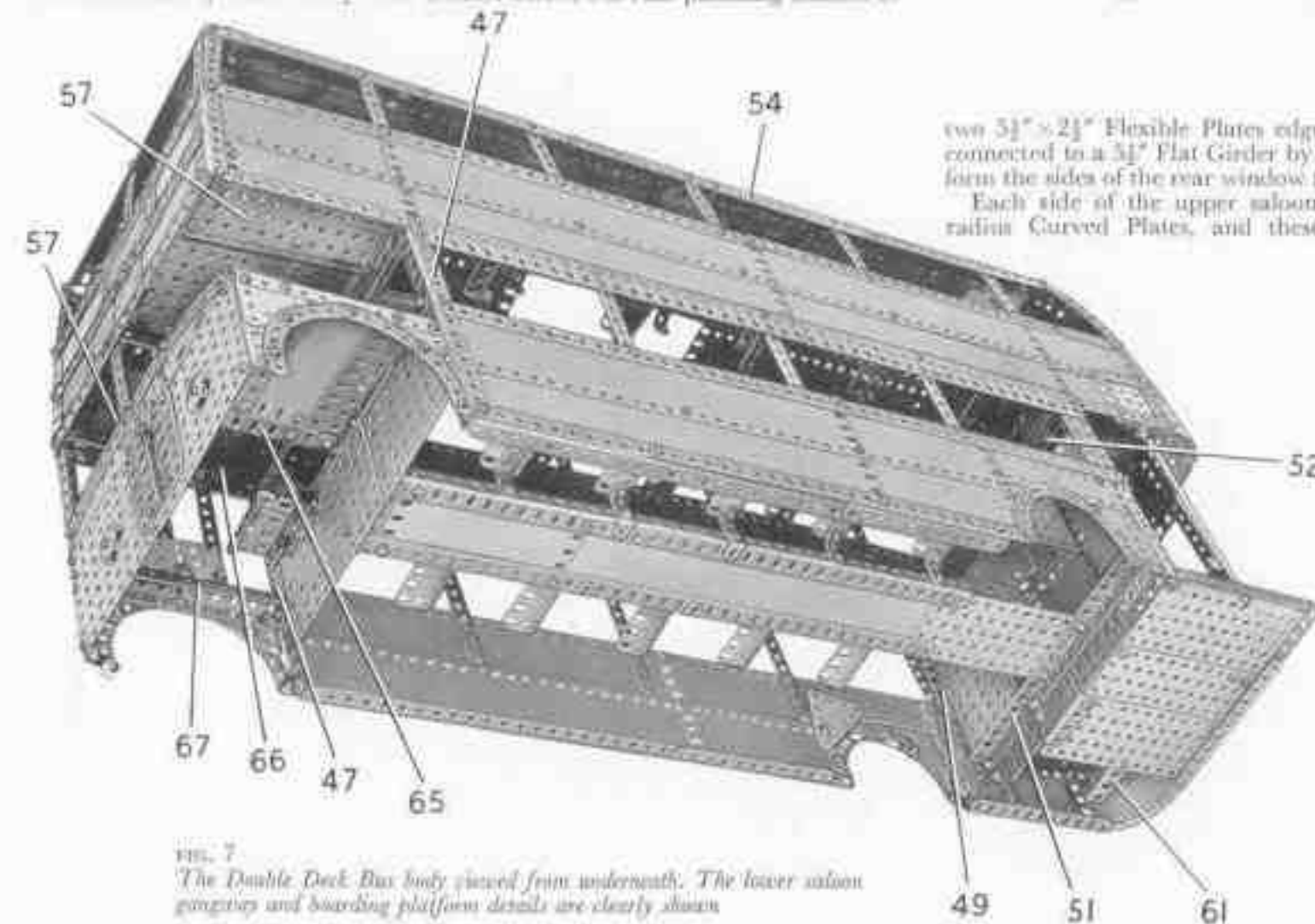

FIG. 7  
The Double Deck Bus body viewed from underneath. The lower saloon gangway and boarding platform details are clearly shown

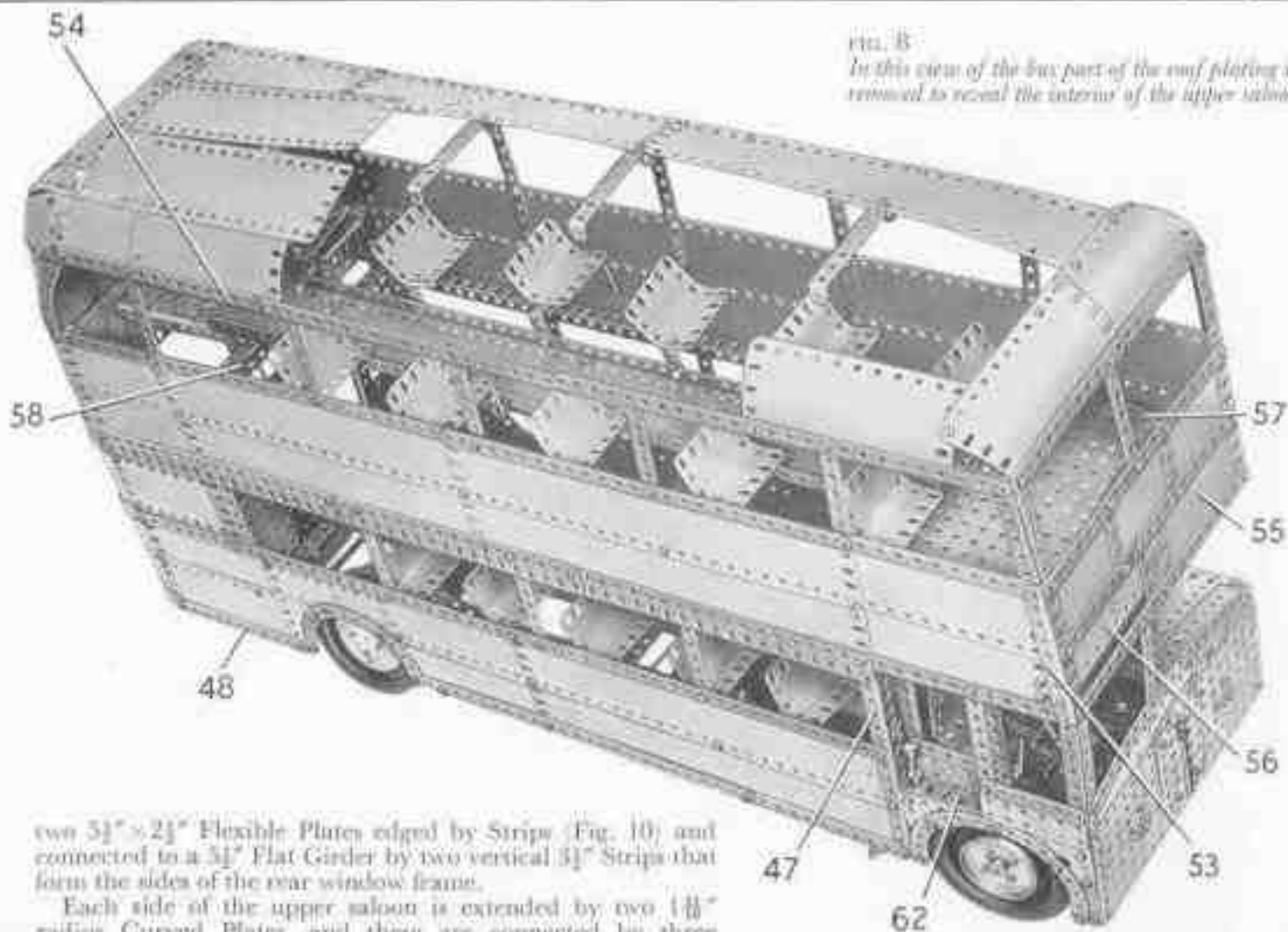

FIG. 8  
In this view of the bus part of the roof plating is removed to reveal the interior of the upper saloon

two  $5\frac{1}{2}$ " x  $2\frac{1}{2}$ " Flexible Plates edged by Strips (Fig. 10) and connected to a  $3\frac{1}{2}$ " Flat Girder by two vertical  $3\frac{1}{2}$ " Strips that form the sides of the rear window frame.

Each side of the upper saloon is extended by two  $1\frac{1}{2}$ " radius Curved Plates, and these

are connected by three  $4\frac{1}{2}$ " x  $2\frac{1}{2}$ " Flexible Plates, a  $2\frac{1}{2}$ " x  $2\frac{1}{2}$ " Flexible Plate and a  $2\frac{1}{2}$ " x  $2\frac{1}{2}$ " Flat Plate. The Flat Plate is recessed by nuts as described previously.

The upper panelling at the rear of the body is completed by a  $4\frac{1}{2}$ " x  $2\frac{1}{2}$ " Flexible Plate (59) (Fig. 10), a  $5\frac{1}{2}$ " x  $1\frac{1}{2}$ " Flexible Plate and a  $3\frac{1}{2}$ " x  $2\frac{1}{2}$ " Triangular Flexible Plate. On the rear side a  $2\frac{1}{2}$ " x  $1\frac{1}{2}$ " Triangular Flexible Plate (60) is bolted in position, but on the off-side this is replaced by a  $3\frac{1}{2}$ " x  $1\frac{1}{2}$ " Triangular Flexible Plate. The plating above the rear window of the upper saloon consists of two  $4\frac{1}{2}$ " x  $2\frac{1}{2}$ " Flexible Plates and two  $2\frac{1}{2}$ " x  $1\frac{1}{2}$ " Flexible Plates.

The platform floor is formed by a  $5\frac{1}{2}$ " x  $3\frac{1}{2}$ " and two  $5\frac{1}{2}$ " x  $2\frac{1}{2}$ " Flat Plates edged by  $5\frac{1}{2}$ " Angle Girders as shown (Figs. 7 and 10). A built-up flat girder, made from a  $7\frac{1}{2}$ " and a  $2\frac{1}{2}$ " Flat Girder, is bolted to a  $9\frac{1}{2}$ " Strip fixed across the Girders (49) and is connected to the floor by a Girder Bracket.

The division between the platform and the saloon on the off-side is a  $4\frac{1}{2}$ " x  $2\frac{1}{2}$ " Flat Plate extended upward by a  $2\frac{1}{2}$ " x  $2\frac{1}{2}$ " Flexible Plate, and on the rear-side it consists of a  $3\frac{1}{2}$ " x  $2\frac{1}{2}$ " Flexible Plate and a  $5\frac{1}{2}$ " Strip.

Each step of the stairs is formed by a  $2\frac{1}{2}$ " x  $1\frac{1}{2}$ " Flexible Plate bolted to a  $2\frac{1}{2}$ " Angle Girder. The steps are connected to each other by Trunnions, and the lower one is bolted to a Girder Bracket fixed to the platform. The side rail is a  $5\frac{1}{2}$ " Braced Girder attached at its lower end to a  $2\frac{1}{2}$ " x  $2\frac{1}{2}$ " Flexible Plate bolted to a  $5\frac{1}{2}$ " Angle Girder (61). The upper end of the Braced Girder is supported by another  $5\frac{1}{2}$ " Angle Girder fixed vertically to the Girder (61).

**Construction of the Roof**

The assembly of this part of the model is shown clearly in Figs. 1, 8 and 10.

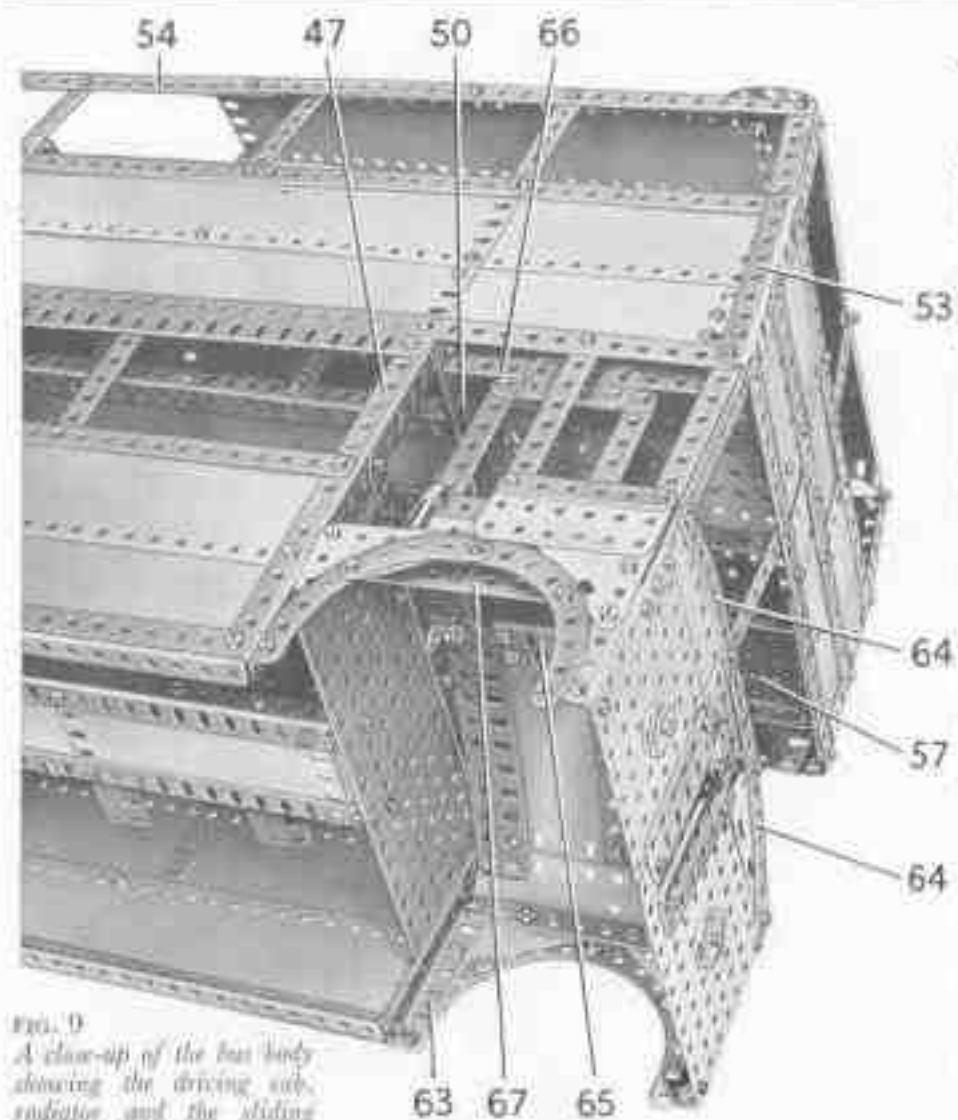

FIG. 9  
A close-up of the bus body showing the driving cab, radiator and the sliding door partly open.

**The Bonnet and Cab (Figs. 8 and 9)**

The off-side of the cab is made by attaching a 3 1/2" Angle Girder (62) (Fig. 8), to the Girder (47) by means of an Angle Bracket. The front end of the Girder (62) is connected to the Girder (53) by a 5 1/2" Strip. The side is plated by a 2 1/4" x 1 1/4" and a 2 1/4" x 2 1/4" Triangular Flexible Plate, and by a 3" x 1 1/4" Flat Plate.

The side of the bonnet (Fig. 1) is a 5 1/2" x 1 1/2" Flexible Plate curved lengthways and bolted to a 3" Angle Girder (63) (Fig. 9). A 2 1/4" x 1 1/4" Triangular Flexible Plate and a 2 1/4" x 2" Triangular Flexible Plate cover the near-side wheel arch. The front of the bonnet is made from two 3 1/2" x 3 1/2" Flat Plates overlapped three holes and bolted to 3" Angle Girders, which are attached to the sides of the cab and bonnet. The Flat Plates are extended upward by a 5 1/2" x 1 1/4" and a 2 1/4" x 1 1/4" Flexible Plate overlapped four holes, and by a 3 1/2" x 1 1/4" Triangular Flexible Plate. The tops of these Plates are edged by two 5 1/2" Curved Strips (64).

A 5 1/2" Angle Girder (65) is attached by Angle Brackets to the Curved Strips (64) and to the partition between the lower saloon and the cab. At each end this Girder is connected to the side of the cab by a curved 5 1/2" Flat Girder. The hinged top of the bonnet consists of two 4 1/2" x 2 1/4" Flexible Plates pivoted on Hinges bolted to the Girder (65).

The sliding door consists of two 3 1/2" Strips joined by a 3" Strip and a 3" x 1 1/4" Flat Plate. A 5 1/2" x 1 1/4" Double Angle Strip (66) is arranged as shown in Fig. 9, and a 3 1/2" Strip (67) is supported at each end by an Angle Bracket. A Fishplate bolted to the Flat Plate of the door slides between the Strip (67) and the edge of the Girder (62). A 2" Flat Girder is bolted to each side of the 3" Strip of the door, but one of them is spaced from the Strip by a 2" Strip. The Flat Girders slide freely on either side of the Double Angle Strip (66).

The driver's seat consists of two 2" Angle Girders connected by a 1 1/4" Flat Girder, and the back is another 1 1/4" Flat Girder supported by two 2" Strips. The seat is connected to the back of the cab by two Double Brackets.

The body is attached to the chassis by bolting the Girders that strengthen the lower edges of the body, to the ends of the

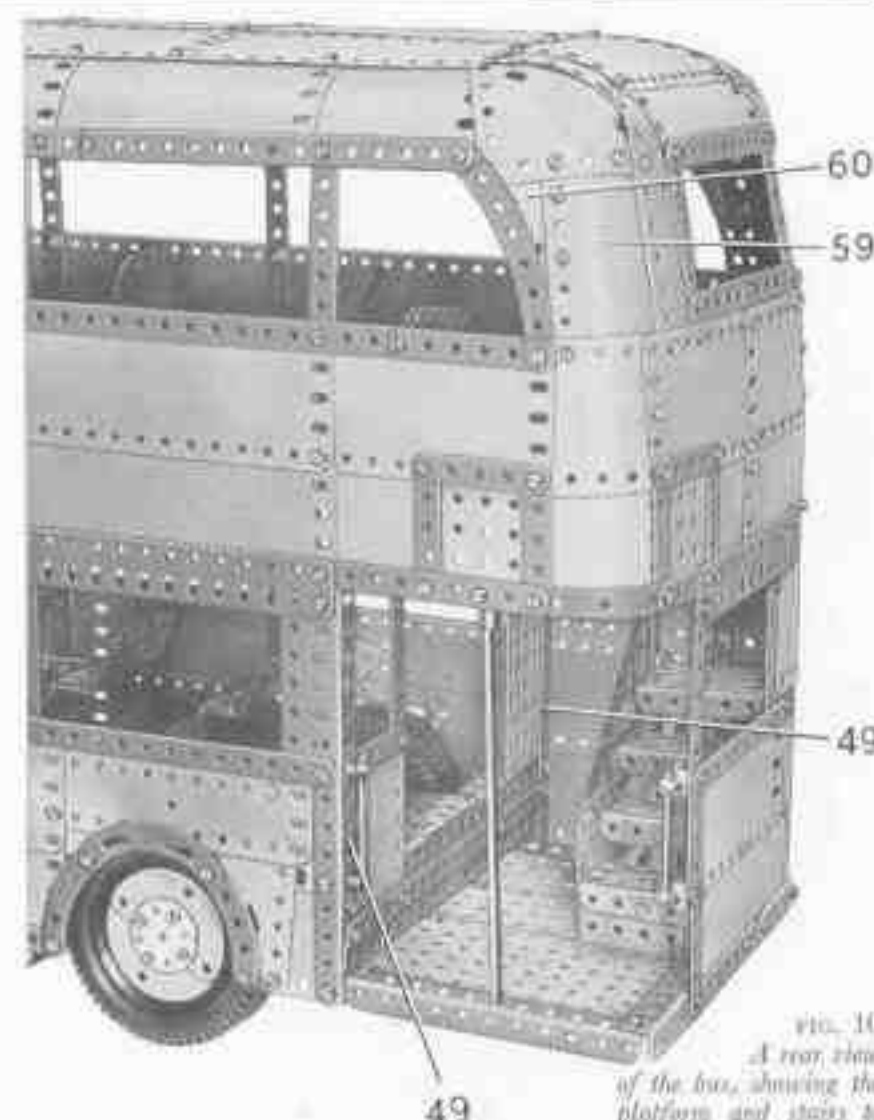

FIG. 10  
A rear view of the bus, showing the platform and stairs to the upper saloon.

Girders (7) and (8) (Fig. 2). At the front the body is spaced from each of the Girders (8) by a Collar.

**Parts Required to Build the Meccano Double Deck Bus**

21 of No. 1	12 of No. 9	2 of No. 15a	1 of No. 27	1 of No. 47	1 of No. 63b	4 of No. 103	2 of No. 114	2 of No. 140	16 of No. 191	2 of No. 226
6 " " 1a	8 " " 9a	6 " " 16	2 " " 27a	2 " " 47a	1 " " 63c	4 " " 103a	2 " " 115	6 " " 142b	30 " " 192	
6 " " 1b	4 " " 9b	4 " " 16a	1 " " 27b	3 " " 48	1 " " 65	4 " " 103b	1 " " 116	1 " " 142c	4 " " 196	
55 " " 2	2 " " 9c	3 " " 16b	2 " " 28	2 " " 48a	4 " " 70	2 " " 103c	2 " " 116a	1 " " 144	20 " " 197	
8 " " 2a	8 " " 9d	6 " " 17	2 " " 29	4 " " 48b	2 " " 72	2 " " 103d	3 " " 120b	2 " " 147b	1 " " 198	
16 " " 3	2 " " 9e	5 " " 18a	1 " " 30a	2 " " 48d	2 " " 73	2 " " 103e	4 " " 124	2 " " 161	12 " " 199	
8 " " 4	7 " " 9f	4 " " 18b	1 " " 30c	2 " " 51	2 " " 77	3 " " 103f	2 " " 125	2 " " 162a	4 " " 200	
28 " " 5	22 " " 10	6 " " 19b	2 " " 31	3 " " 52	1 " " 78	2 " " 103g	3 " " 126	2 " " 165	4 " " 212	
12 " " 6	4 " " 11	1 " " 20a	713 " " 35a	6 " " 52a	2 " " 82	4 " " 103h	1 " " 126a	1 " " 171	4 " " 214	
8 " " 6a	46 " " 12	3 " " 22a	638 " " 37b	4 " " 53a	4 " " 89	1 " " 103k	2 " " 128	1 " " 175	4 " " 215	
4 " " 7	8 " " 12a	1 " " 23	72 " " 38	2 " " 53a	4 " " 89a	2 " " 109	4 " " 133	2 " " 179	4 " " 221	
2 " " 7a	7 " " 12b	2 " " 24a	2 " " 38d	23 " " 59	6 " " 89b	4 " " 111	2 " " 133a	10 " " 188	2 " " 222	1 E15R Electric Motor (not included in Outfit)
6 " " 8	1 " " 13a	5 " " 25	2 " " 43	4 " " 62	12 " " 90	16 " " 111a	4 " " 136	11 " " 189	1 " " 223	
6 " " 8a	2 " " 14	7 " " 26	2 " " 45	4 " " 62b	3 " " 90a	24 " " 111c	1 " " 136a	12 " " 190	2 " " 224	
5 " " 8b	1 " " 15	1 " " 26c	4 " " 46	8 " " 63	1 " " 100	1 " " 111d	4 " " 137	4 " " 198a	2 " " 225	