

**MECCANO**<sup>TM</sup>  
ENGINEERING & ROBOTICS

**CORVETTE**   
CHEVROLET

17301

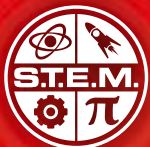

 **10+**

Instructions  
Notice de montage  
Instrucciones de construcción  
Bauanleitung

Bouwinstructie  
Istruzioni  
Instruções  
Инструкции

Instrukcja  
Pokyny  
Útmutató  
Instruções





### CONSTRUCTION TIPS / ASTUCES DE CONSTRUCTION

TIPS DE CONSTRUCCIÓ / TIPPS ZUM BAUEN / MONTAGETIPS / SUGGERIMENTI PER COSTRUIRE  
DICAS DE MONTAGEM / РЕКОМЕНДАЦИИ ПО СБОРКЕ / WSKAZÓWKI BUDOWANIA  
KONSTRUKČNÍ TIPY / TIPY NA MONTÁŽ / ÖSSZESZERELÉSI TIPPEK / SFATURI PENTRU CONSTRUIRE

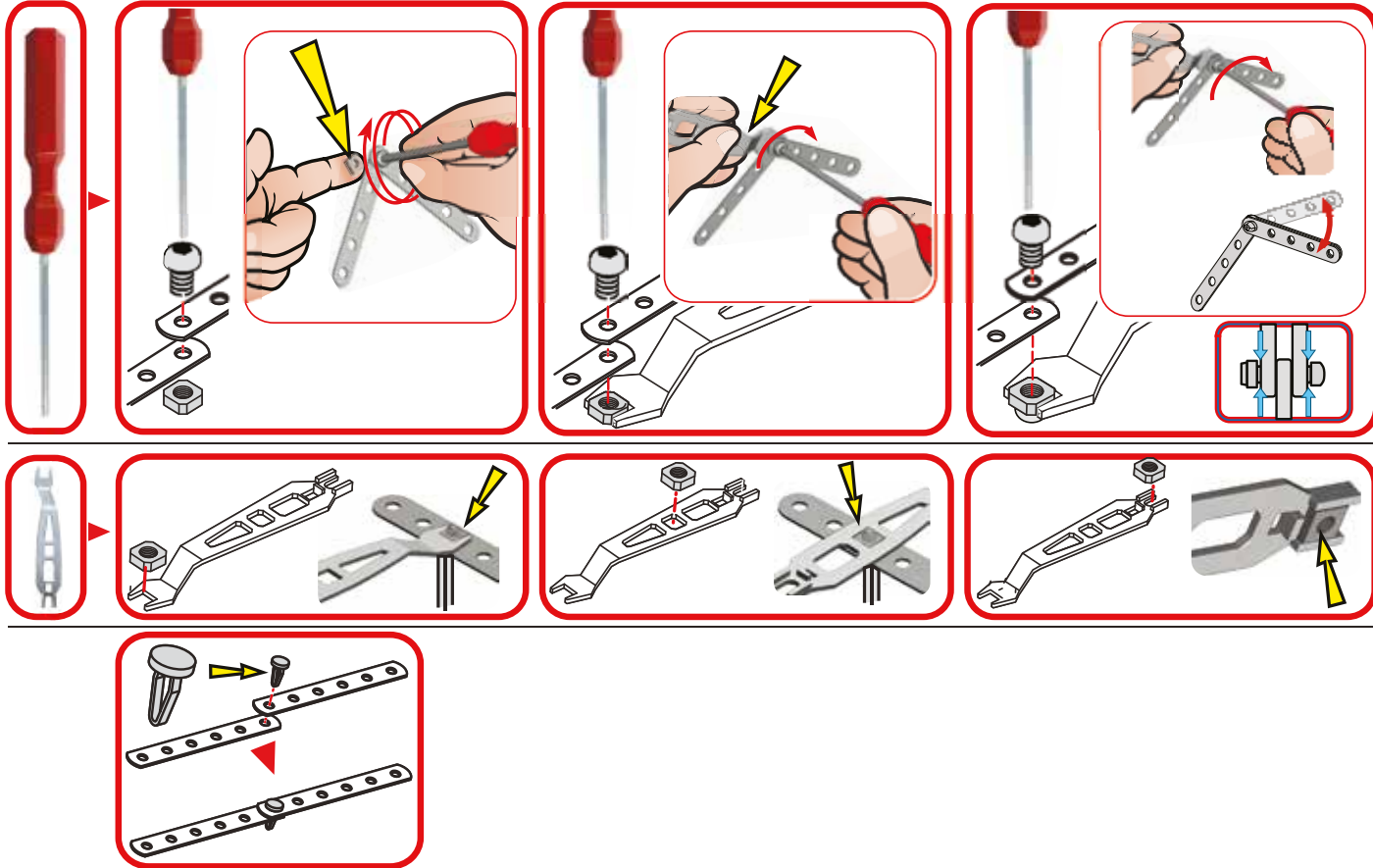

# TABLE OF CONTENTS / SOMMAIRE

## ÍNDICE / INHALTSVERZEICHNIS / INHOUD / INDICE / СОДЕРЖАНИЕ

### SPIS TREŚCI / OBSAH / TARTALOMJEGYZÉK / CUPRINS



**EN.** Content: 279 parts, 2 real tools, 1 sticker sheet, 1 instruction sheet for 1 model.

**FR.** Contenu : 279 pièces, 2 vrais outils, 1 feuillet d'autocollants, 1 notice de montage pour 1 modèle.

**ES.** Contenido: 279 piezas, 2 herramientas reales, 1 hoja de calcomanías, 1 guía de instrucciones para 1 modelo.

**DE.** Inhalt: 279 Teile, 2 echte Werkzeuge, 1 Bogen mit Aufklebern, 1 Bauanleitung für 1 Modell.

**NL.** Inhoud: 279 onderdelen, 2 stuks gereedschap, 1 stickervel, 1 bouw instructie voor 1 model.

**IT.** Contenuto: 279 pezzi, 2 attrezzi, 1 foglio di adesivi, 1 guida per l'uso per 1 modello.

**PT.** Conteúdo: 279 peças, 2 ferramentas reais, 1 cartela de adesivos, 1 folha de instruções para 1 modelo.

**RU.** В комплекте: 279 деталей, 2 настоящих инструмента, 1 лист с наклейками, 1 инструкция по сборке 1 модели.

**PL.** Zawartość: 279 elementów, 2 prawdziwe narzędzia, 1 karta z naklejkami, 1 karta z instrukcjami dla 1 modelu.

**CZ.** Obsah: 279 dílů, 2 skutečné nástroje, 1 list se samolepkami, 1 list s pokyny pro 1 model.

**SK.** Obsah: 279 dielov, 2 skutočné nástroje, 1 hárok s nálepkami, 1 hárok s pokynmi pre 1 model.

**HU.** Tartalom: 279 db alkatrész, 2 db valódi szerszám, 1 db matricapapír, 1 db 1 modellhez tartozó felhasználói útmutató.

**RO.** Conținut: 279 de piese, 2 instrumente reale, 1 foaie cu autocolante, 1 fișă cu instrucțiuni pentru 1 model.

⚠ CAUTION: Stickers not intended to be placed on skin.

⚠ MISE EN GARDE: Les autocollants ne sont pas destinés à être placés sur la peau.

⚠ PRECAUCIÓN: Las calcomanías no deben colocarse sobre la piel.

⚠ ACHTUNG: Sticker sind nicht zum Aufkleben auf die Haut geeignet.

⚠ VOORZICHTIG: Stickers zijn niet voor op de huid bedoeld.

⚠ ATTENZIONE: Non applicare gli adesivi sulla pelle.

⚠ CUIDADO: Não aplique os adesivos na pele.

⚠ ОСТОРОЖНО: Стикеры не предназначены для приклеивания к коже.

⚠ OSTRZEŻENIE: Naklejki nie należy umieszczać na skórze.

⚠ POZOR: Samolepky nejsou určeny k lepení na kůži.





⚠ UPOZORNENIE: Nálepky nie sú určené na nalepenie na pokožku.

⚠ VIGYÁZAT! A matricák nem alkalmasak a bőrre történő ragasztásra.

⚠ ATENȚIE: Autocolantele nu sunt destinate lipirii pe piele.



1



-  9,5 mm | 3/8" | x4
-  x4
-  x2
-  x1

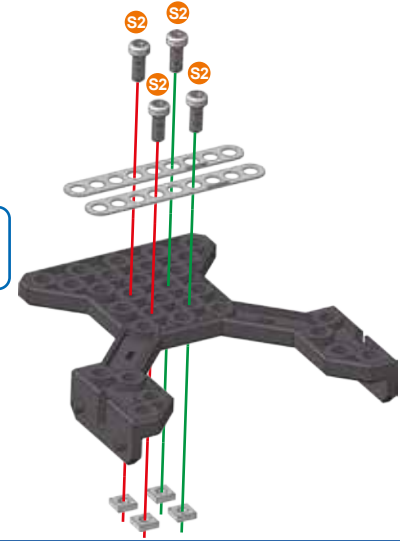

-  1:1





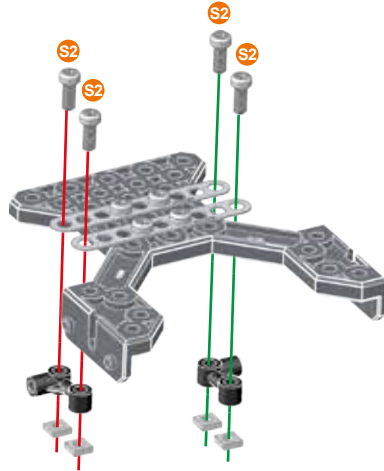

2

-  9,5 mm | 3/8" | x4
-  x2
-  x4

-  1:1



3

-  12 mm | 1/2" | x4
-  x2
-  x2
-  x2
-  x1

-  1:1
-  D277

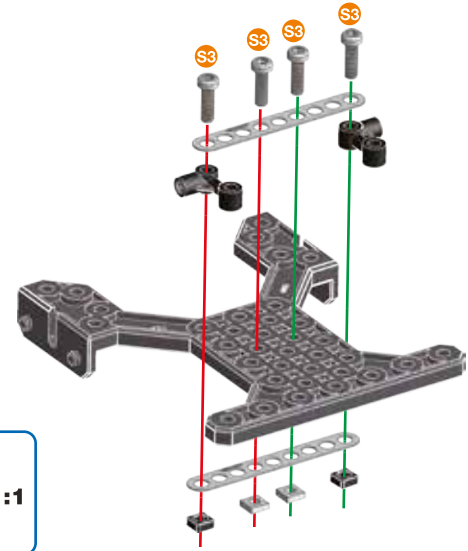

**4**

	<b>x1</b>
	<b>x2</b>
	<b>x2</b>

	<b>x1</b>
	<b>x1</b>
	<b>x1</b>
<b>1:1</b>	

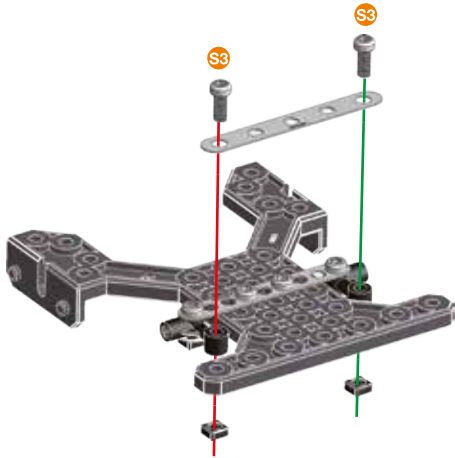

**6**

	<b>x2</b>
	<b>x2</b>
	<b>x2</b>
	<b>x2</b>

	<b>x1</b>
<b>1:1</b>	

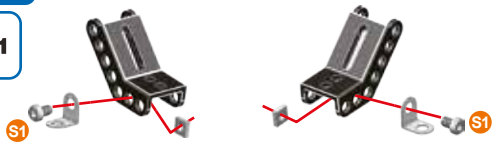



**5** ③ + ④ +

	<b>x4</b>
	<b>x4</b>
	<b>x2</b>

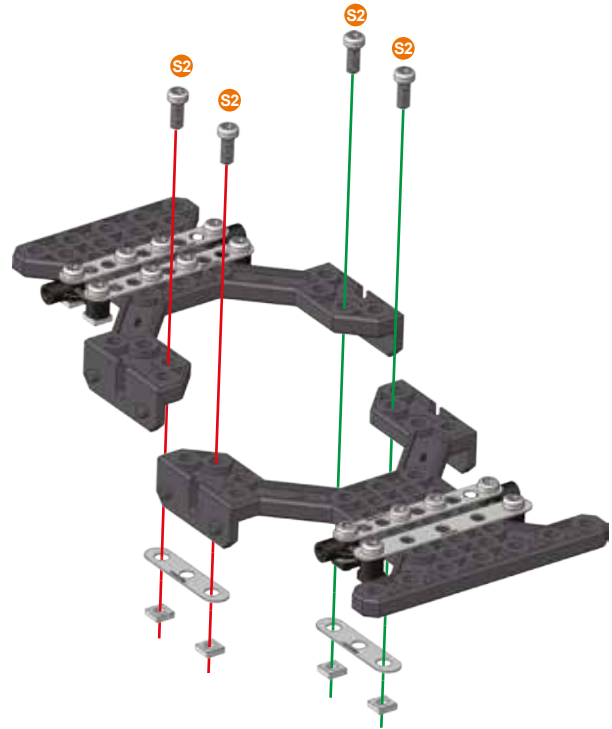
	<b>x1</b>
<b>1:1</b>	







**7** (5) + (6) +

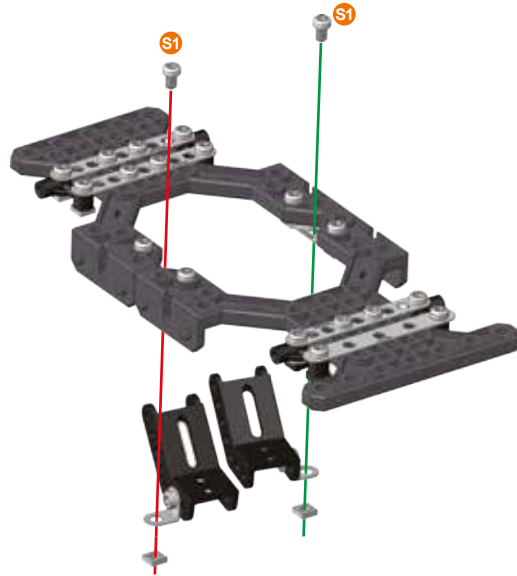

	S1	5,8 mm	x2
		15/64"	x2

	S1	1:1
---	----	-----







**8**

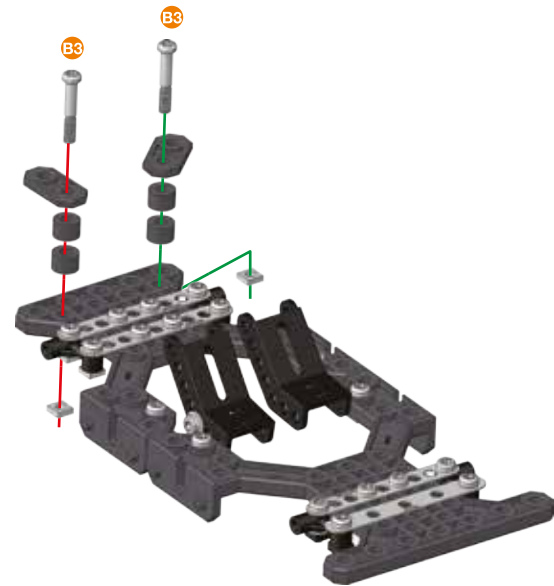

	B3	23 mm	x2
		15/16"	x2
			x2
			x4
			x2

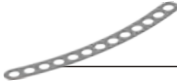
	B3	1:1
	A238	1:1



**9**

			x1
			x2
	S3	12 mm	x2
		1/2"	x2
			x2

	S3	1:1
	A338	1:1

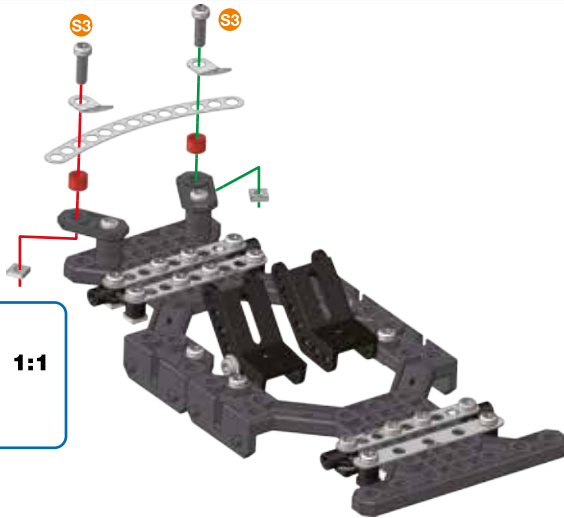

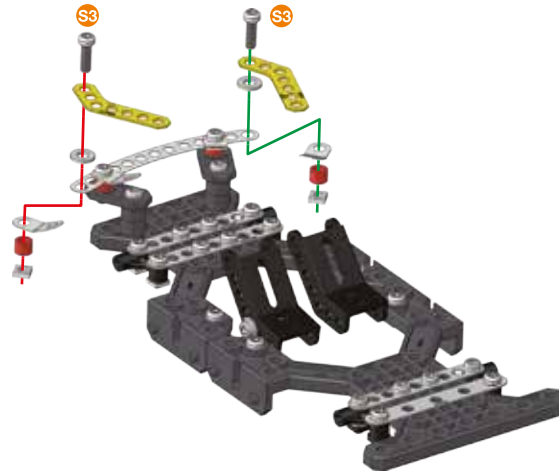
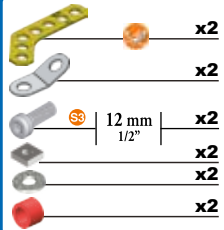
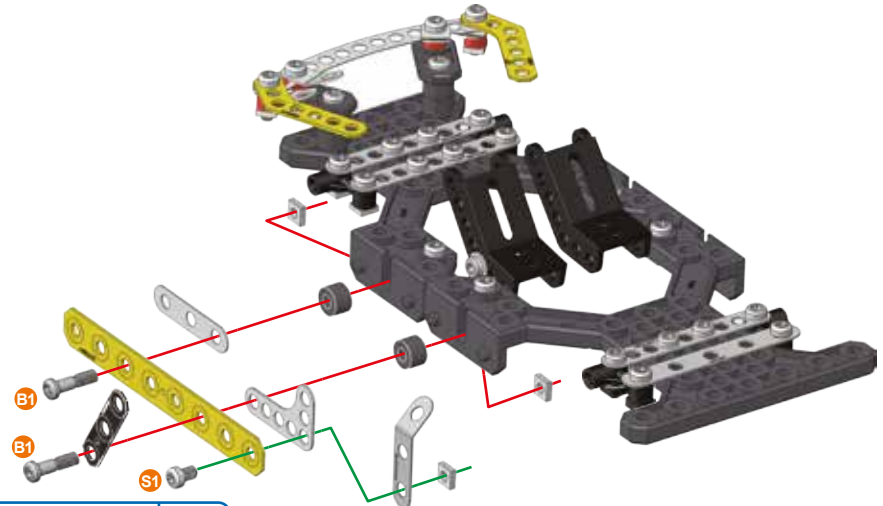
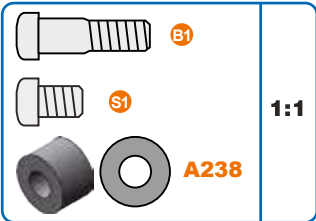
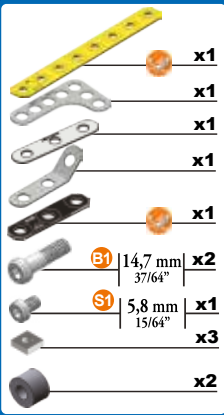
**10****11**

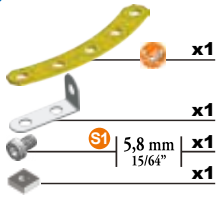
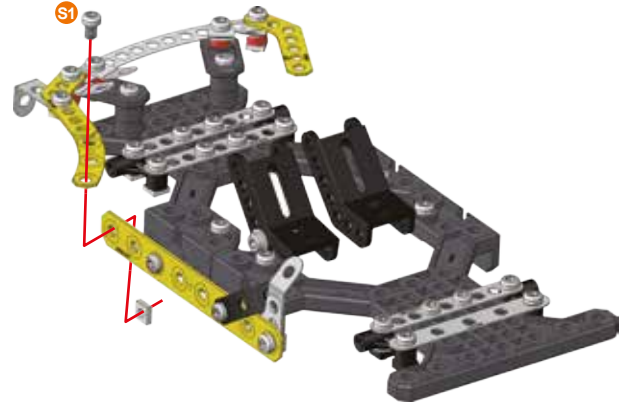
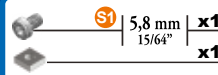
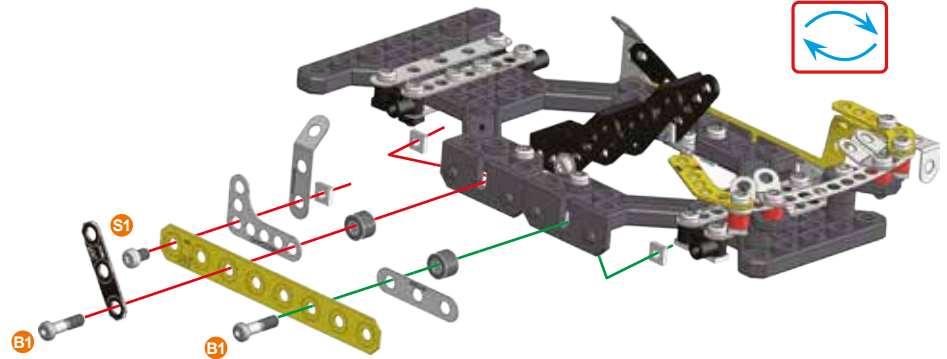
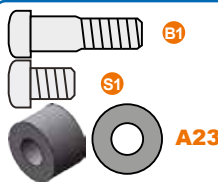
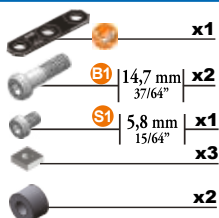
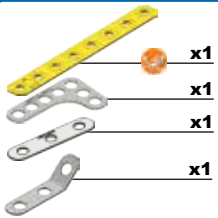
**12****13****14**



15

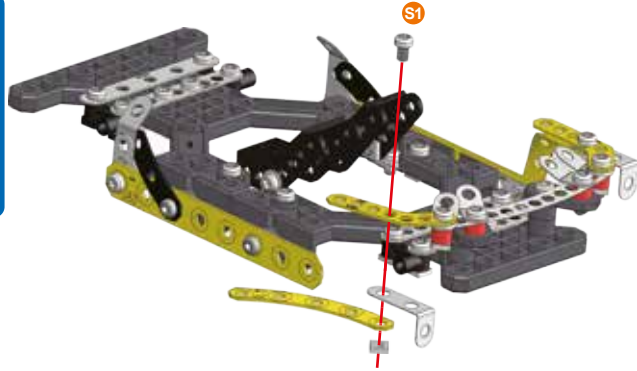
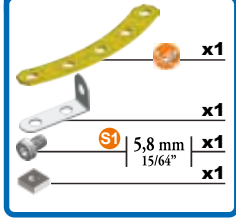

16

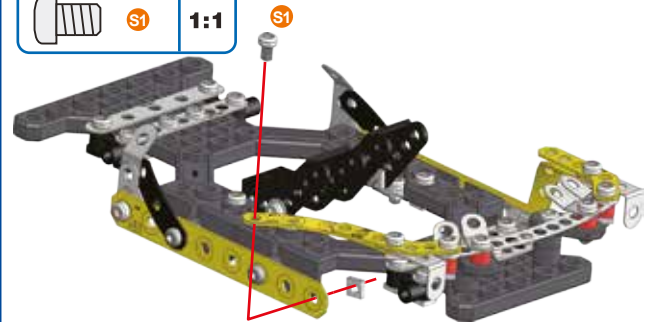
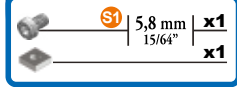

17

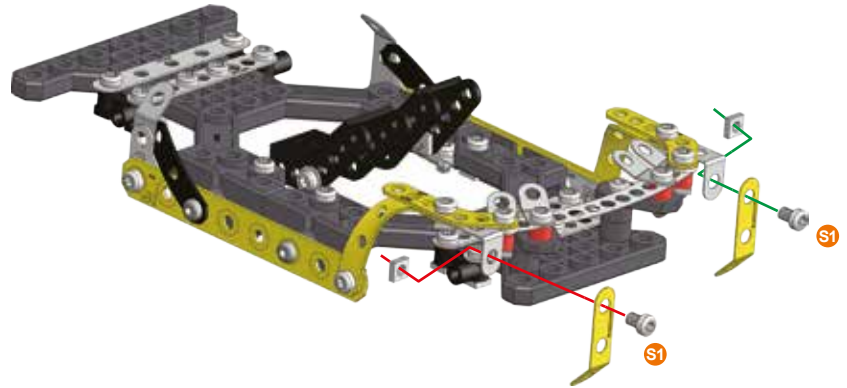
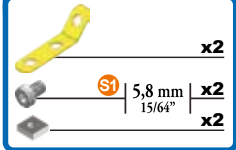

18

	x2
	x2
5,8 mm 15/64"	x2
	x2

	S1	1:1
--	----	-----

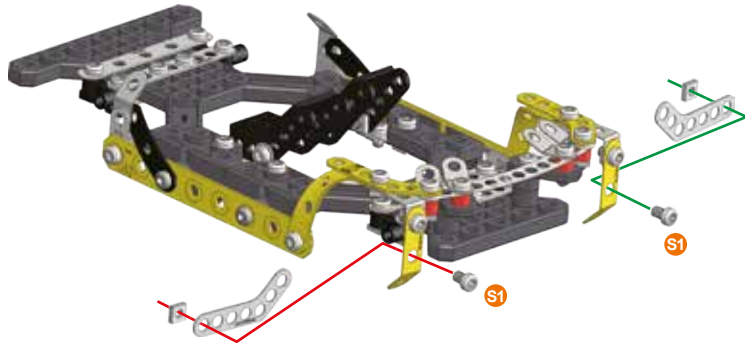

19

	S1	5,8 mm 15/64"	x2
	S1		x2
			x1

	S1	1:1
--	----	-----

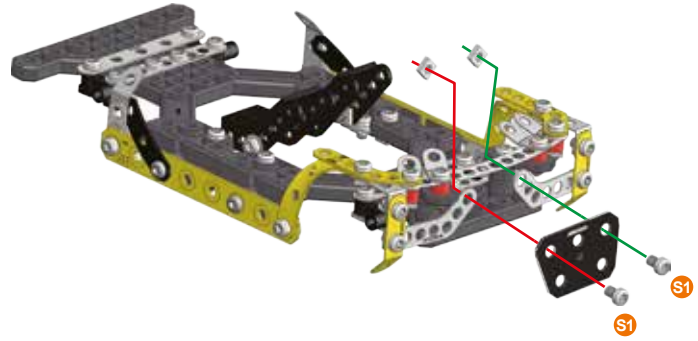



20

	B3	23 mm 15/16"	x2
			x2
			x2
			x2
			x2
			x2

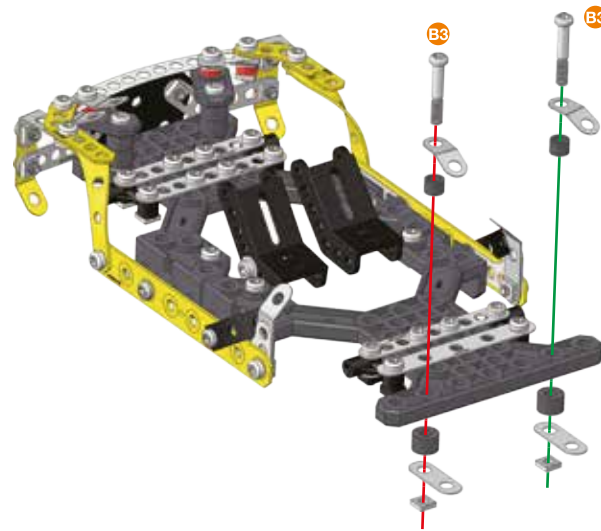
	B3	1:1
	A238	
	A338	



# 21

-  **x2**
-  **S1** | 5,8 mm | **x2**
-  **x2**

-  **S1** | **1:1**

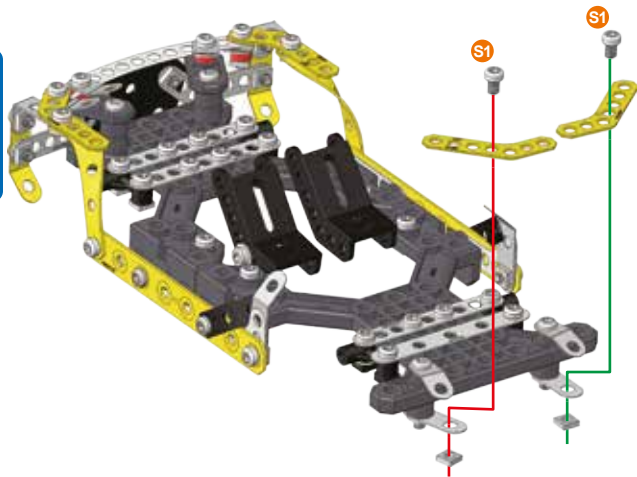





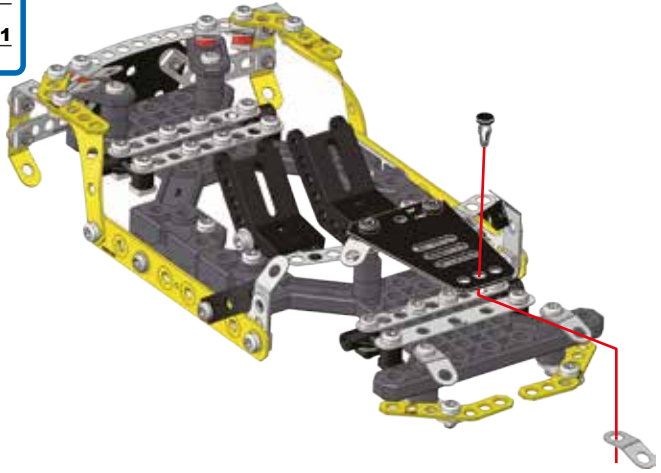







# 23

-  **x1**
-  **x1**



# 22

-  **x1**
-  **x1**
-  **C1** | 32 mm | **x2**
-  **x2**
-  **x4**
-  **x4**
-  **x2**

-  **C1**
-  **A238**
-  **A338**
-  **A338**
-  **A338**
- 1:1**

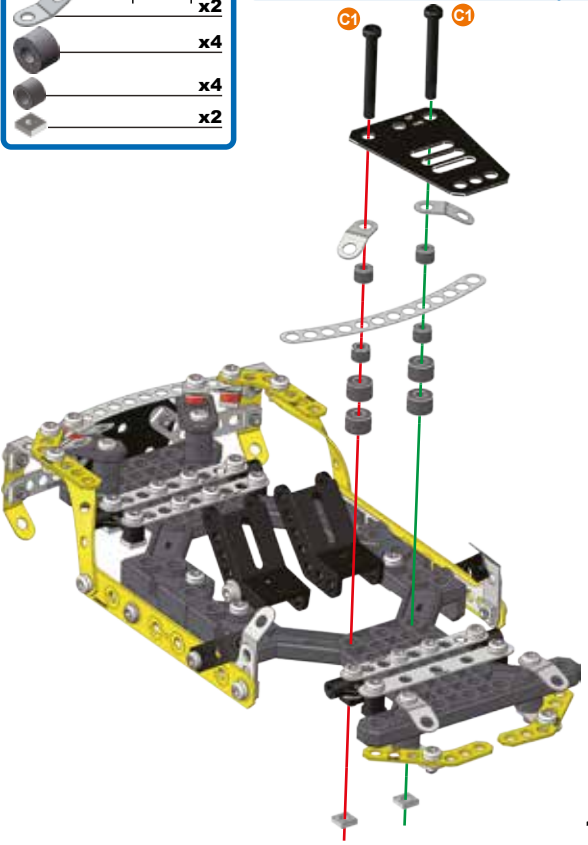

24

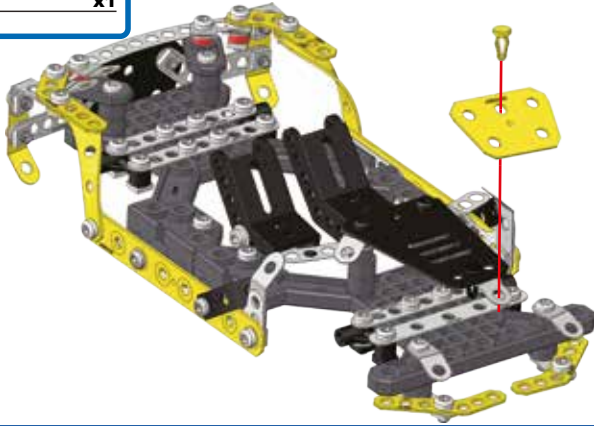
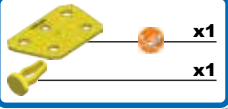

25

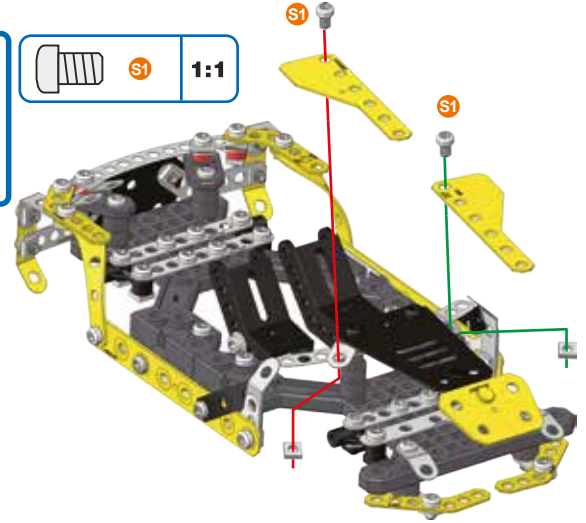
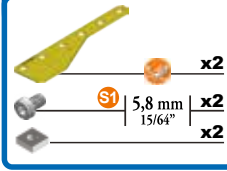

26

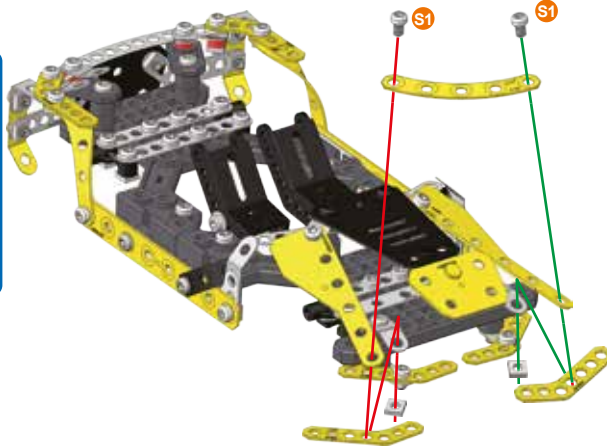
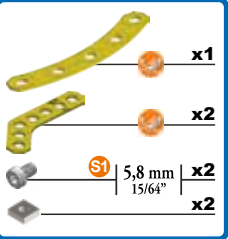

27

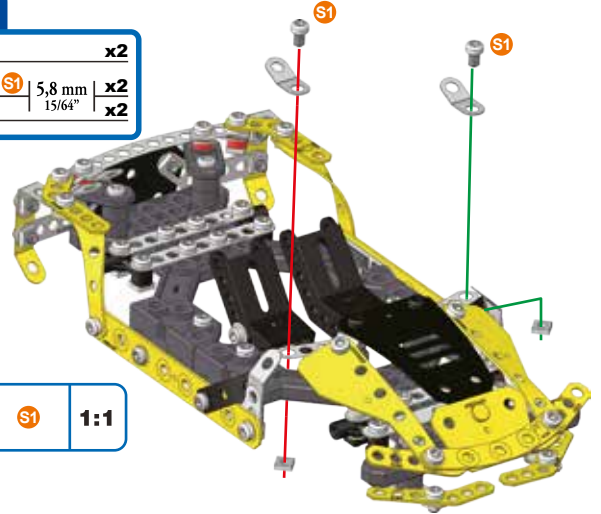
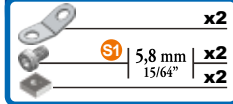

28

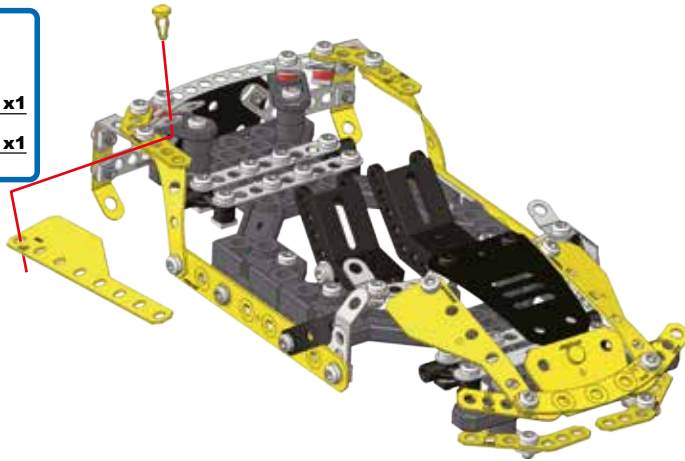
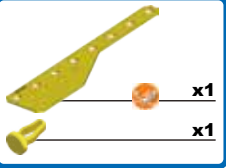

29

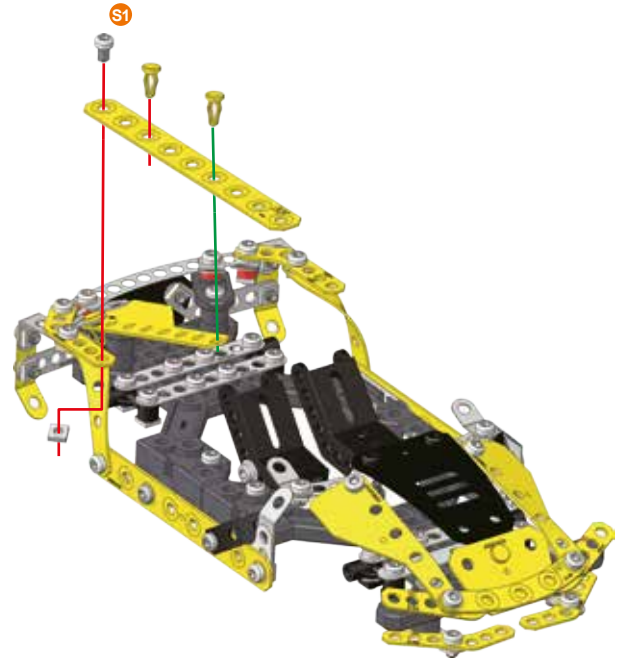
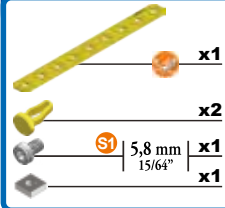

30

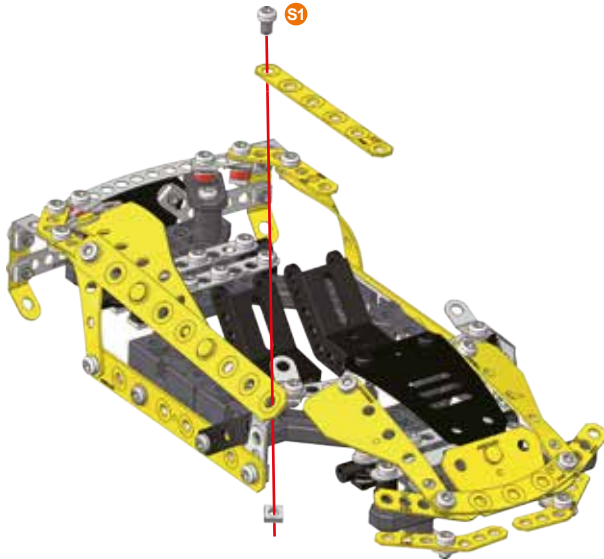
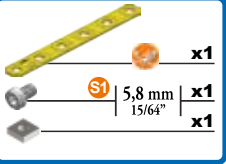



31

 **S1** | 5,8 mm | **x1**  
15/64" | **x1**

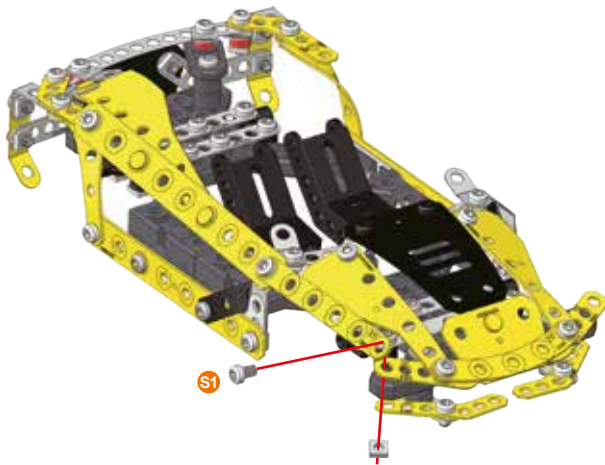
 **S1** | **1:1**



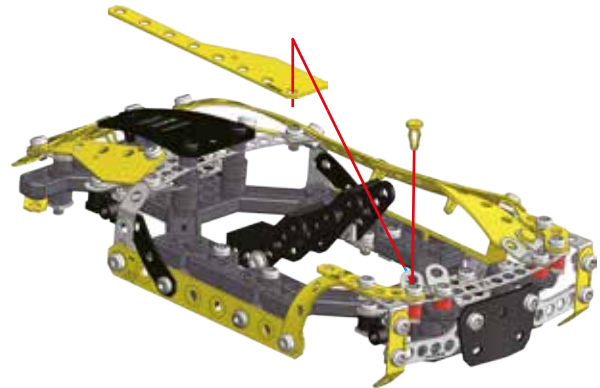

32

 **x1**  
 **x1**

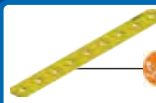

33

 **x1**  
 **x2**  
 **S1** | 5,8 mm | **x1**  
15/64" | **x1**

 **S1** | **1:1**

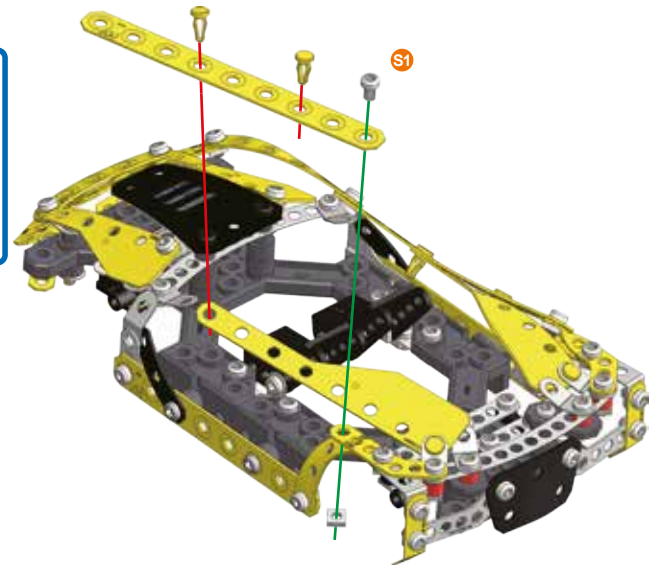

34

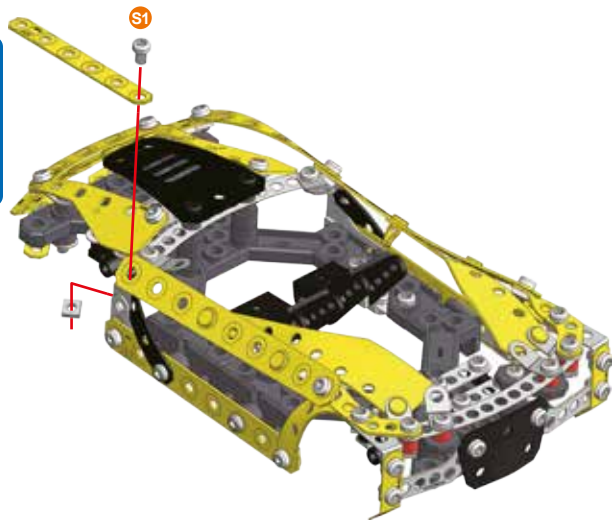
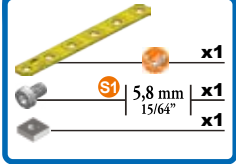

35

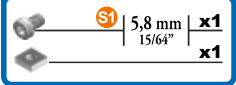

36

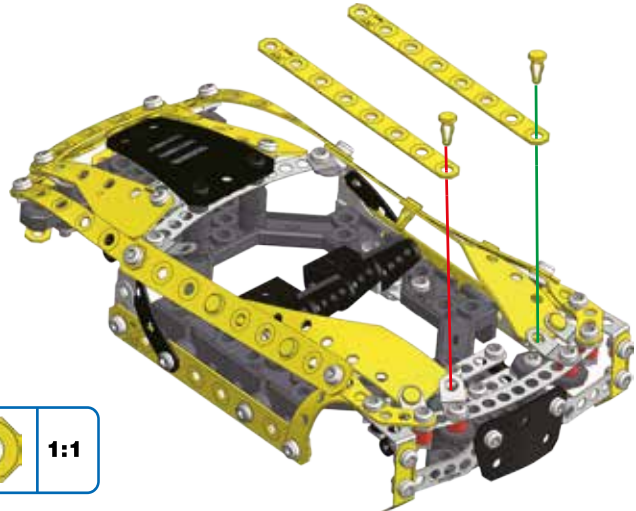
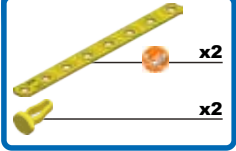

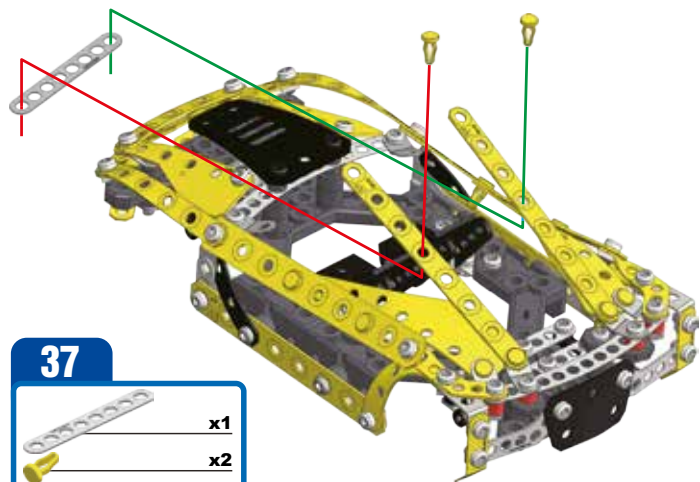

**37**

	x1
	x2

**38**

	x1
	x2
	x2
	x2

S1 1:1

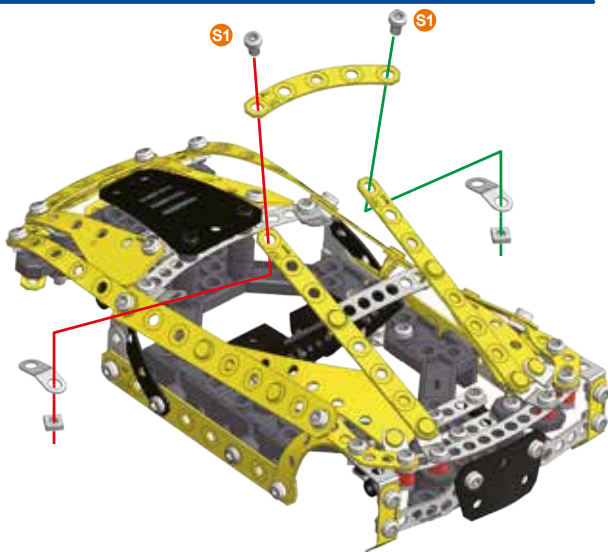

**39**



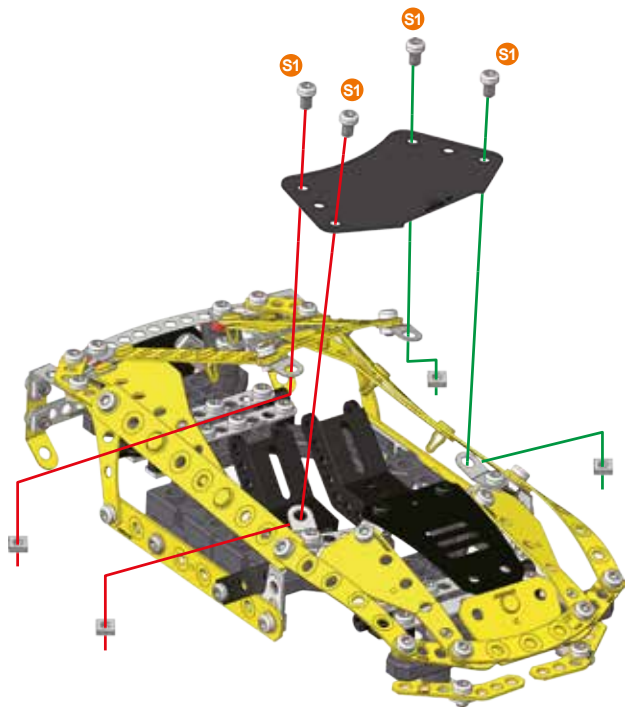

	x1
	x4
	x4

S1 1:1



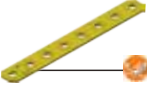

40

-  x1
-  | 12 mm | x1
-  | x1
-  | x1

-  S3
-  |  A338





1:1

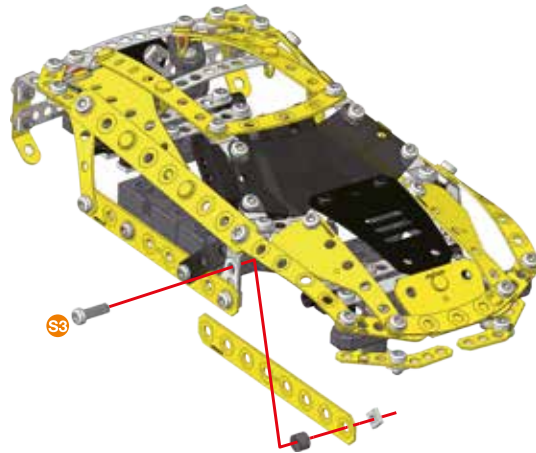

1:1

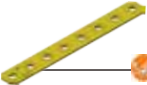

41

-  x1
-  | 12 mm | x1
-  | x1
-  | x1

-  S3
-  |  A338

1:1



1:1

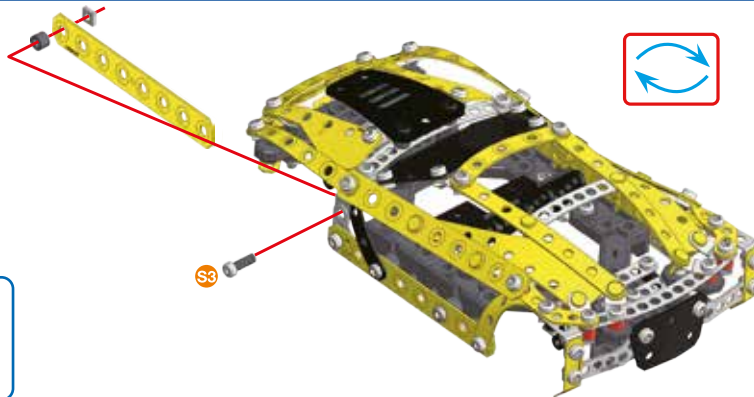

42

-  x2
-  x2



x2



43





-  x2
-  x2

x2





# 44

(41) + (42) + (43) +

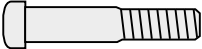

-  **B3** 23 mm | x2  
15/16"
-  **B2** 19 mm | x2  
3/4"
-  x4
-  x2
-  x2

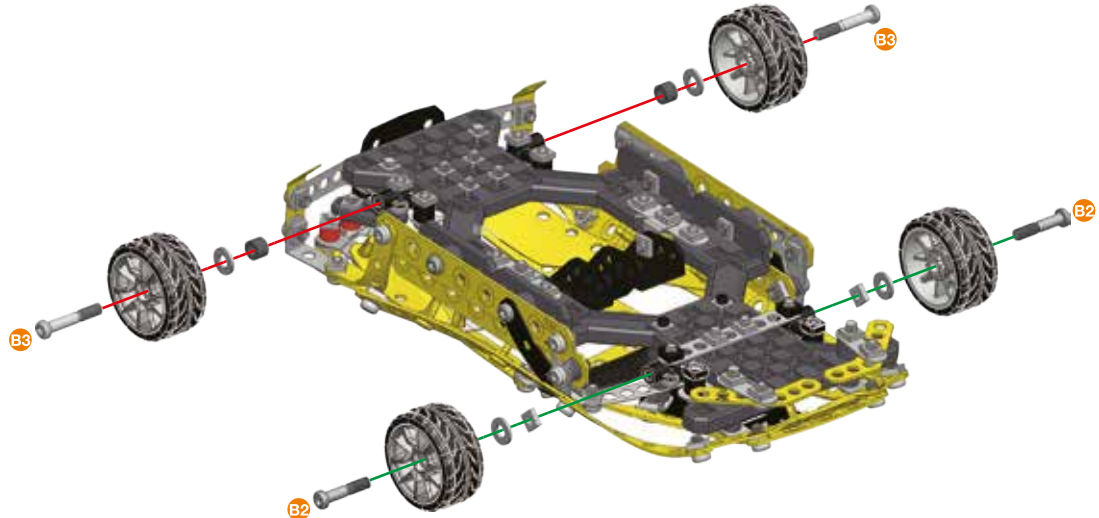

-  **B3**
  -  **B2**
  -  **A338**
- 1:1**



# 45

-  **3** x1
-  **1** x1







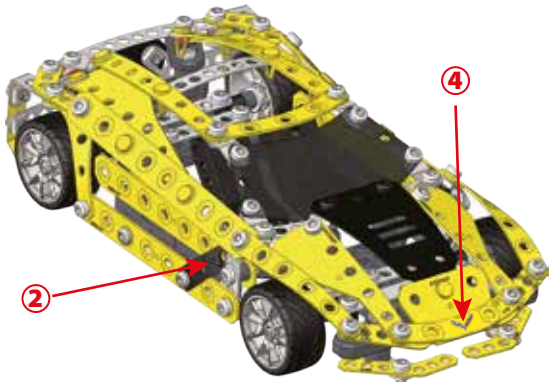











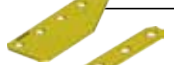

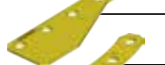



























# 46

-  **2** x1
-  **4** x1

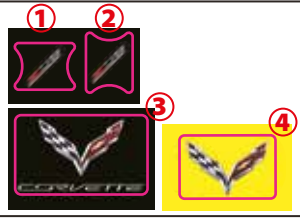

	<b>D260 x1</b>
	<b>D259 x1</b>
	<b>D323 x1</b>
	 <b>D314 x1</b>
	<b>C887 x2</b>
	 <b>D240 x1</b>
	 <b>D240 x1</b>
	<b>D247 x4</b>
	<b>D310 x4</b>
	<b>A423 x4</b>
	<b>D277 x4</b>
	<b>D005 x11</b>
	<b>D005 x1</b>
	<b>C330 x2</b>
	<b>A806 x2</b>
	<b>C483 x13</b>

	 <b>D110 x2</b>
	 <b>D140 x2</b>
	 <b>D126 x4</b>
	 <b>D206 x2</b>
	 <b>D210 x2</b>
	 <b>D339 x2</b>
	 <b>D111 x4</b>
	 <b>D339 x2</b>
	<b>C779 x2</b>
	<b>C771 x4</b>
	<b>A235 x1</b>
	<b>C770 x1</b>
	<b>C776 x2</b>
	<b>A416 x4</b>
	<b>A437 x2</b>
	<b>A437 x2</b>
	<b>A812 x2</b>
	<b>C775 x2</b>
	<b>D100 x2</b>
	<b>D313 x6</b>
	<b>D048 x2</b>

	 <b>32 mm</b>	<b>C935 x2</b>
	 <b>23 mm</b>	<b>A347 x6</b>
	 <b>19 mm</b>	<b>A447 x2</b>
	 <b>14,7 mm</b>	<b>A247 x4</b>
	 <b>12 mm</b>	<b>A411 x12</b>
	 <b>9,5 mm</b>	<b>A511 x12</b>
	 <b>5,8 mm</b>	<b>A637 x36</b>
		<b>A138 x6</b>
		<b>A337 x68</b>
		<b>A238 x14</b>
		<b>A338 x10</b>
		<b>A338 x4</b>
		<b>x1</b>
		<b>C994 x1</b>
		<b>C993 x1</b>

**EN.** Remove all packaging before use. Retain this information, addresses and phone numbers for future reference. Content may vary from pictures. Meccano reserves the right to discontinue the website [www.meccano.com](http://www.meccano.com) at any time. An adult should periodically check this toy to ensure no damage or hazards exist, if so, remove from use. Children should be supervised during play.

**FR.** Retirer tout l'emballage avant utilisation. Conserver les informations, adresses et numéros de téléphone pour consultation ultérieure. Le contenu peut différer des images. Meccano se réserve le droit de supprimer le site Internet [www.meccano.com](http://www.meccano.com) à tout moment. Le contenu peut différer des images. Un adulte doit régulièrement examiner ce jouet afin de s'assurer qu'il ne présente pas de dommage ni de risque. En cas de problème, ne plus l'utiliser. Les enfants doivent être surveillés lorsqu'ils jouent.

**ES.** Retire todo el embalaje antes de utilizar el producto. Conserve toda la información, las direcciones y los números de teléfono para futuras referencias. El contenido del paquete puede no corresponder con las imágenes. Meccano se reserva el derecho a suspender el sitio web [www.meccano.com](http://www.meccano.com) en cualquier momento. Un adulto debe revisar de forma periódica el juguete para asegurarse de que no supone un riesgo para el niño; si así fuera el caso, interrumpa su uso. Supervise a los niños mientras juegan con el producto.

**DE.** Entfernen Sie vor der Benutzung sämtliche Verpackungsmaterialien. Alle Informationen, Adressen und Telefonnummern bitte für mögliche Rückfragen aufbewahren. Der Packungsinhalt kann von den Bildern abweichen. Meccano behält sich das Recht vor, den Betrieb der Website [www.meccano.com](http://www.meccano.com) jederzeit einzustellen. Ein Erwachsener sollte regelmäßig sicherstellen, dass das Spielzeug keine Gefahr darstellt, und es gegebenenfalls entfernen. Kinder sollten beim Spielen beaufsichtigt werden.

**NL.** Verwijder de verpakking voor gebruik. Bewaar deze informatie, adressen en telefoonnummers voor toekomstig gebruik. Inhoud kan afwijken van illustraties. Meccano behoudt zich het recht voor de website [www.meccano.com](http://www.meccano.com) wanneer gewenst buiten gebruik te stellen. Een volwassene dient dit speelgoed regelmatig te controleren. In geval van schade of gevaaren het speelgoed niet meer gebruiken. Houd toezicht als kinderen spelen.

**IT.** Rimuovere l'imballo prima dell'uso. Conservare informazioni, indirizzi e numeri di telefono per riferimento futuro. Il prodotto potrebbe essere differente dalle immagini. Meccano si riserva il diritto di rimuovere il sito [www.meccano.com](http://www.meccano.com) in qualsiasi momento. Il giocattolo deve essere periodicamente controllato da un adulto per prevenire eventuali danni o rischi; in caso di danno, sospendere l'uso. I bambini devono essere sorvegliati durante il gioco.

**PT.** Remova totalmente a embalagem antes de utilizar. Guarde todos os endereços, números de telefone e demais informações para consulta e referência. O conteúdo poderá ser diferente das ilustrações. A Meccano reserva-se o direito de descontinuar o site [www.meccano.com](http://www.meccano.com) a qualquer altura. Um adulto deve verificar o brinquedo periodicamente para garantir que não há danos ou riscos. Se houver, é necessário que o brinquedo seja retirado de uso. As crianças devem ser supervisionadas enquanto brincam.

**RU.** Снимите все упаковочные материалы перед использованием. Запишите указанные на упаковке адреса и номера телефонов, чтобы у вас была возможность связаться с нами. Содержимое упаковки может отличаться от иллюстраций. Компания Meccano оставляет за собой право прекратить использование сайта [www.meccano.com](http://www.meccano.com) в любое время. Взрослым следует время от времени проверять игру и следить за тем, чтобы она не была сломана и не представляла опасности для ребенка. В противном случае ее не следует использовать. Во время игры дети должны находиться под присмотром.

**PL.** Przed użyciem wyjąć zabawkę z opakowania. Zachować niniejsze informacje, adresy i numery telefonów na wypadek, gdyby były potrzebne w przyszłości. Zawartość opakowania może różnić się od zabawki przedstawionej na obrazkach. Firma Meccano zastrzega sobie prawo do zaprzestania korzystania z witryny [www.meccano.com](http://www.meccano.com) w dowolnym momencie. Osoba dorosła powinna regularnie sprawdzać zabawkę pod kątem uszkodzeń oraz zagrożeń. Jeśli takowe wystąpią, należy zaprzestać używania zabawki. Dzieci nie powinny bawić się bez nadzoru.

**CZ.** Před použitím odstraníte veškeré balící materiály. Uložte si tyto informace, adresy a telefonní čísla pro budoucí použití. Obsah se může lišit od obrázků. Společnost Meccano si vyhrazuje právo kdykoli ukončit web [www.meccano.com](http://www.meccano.com). Dospělá osoba by měla pravidelně kontrolovat, zda hračka není poškozená nebo zda nepředstavuje nebezpečí. Pokud ano, hračku vyhodte. Během hry nenechávejte děti bez dozoru.

**SK.** Pred použitím odstráňte všetok obalový materiál. Tieto informácie, adresy a telefónne čísla si uchovajte na ďalšie použitie. Obsah sa môže líšiť od zobrazenia. Spoločnosť Meccano si vyhradzuje právo kedykoľvek ukončiť používanie webovej lokality [www.meccano.com](http://www.meccano.com). Túto hračku musí pravidelne kontrolovať dospelá osoba, aby sa uistila, že nedošlo k jej poškodeniu a že nehrozí žiadne nebezpečenstvo. Ak áno, ukončíte jej používanie. Deti nesmú byť pri hre bez dozoru.

**HU.** Használat előtt távolítsd el minden csomagolóanyagot. A tudnivalókat, a címet és a telefonszámot őrizze meg későbbi használatra. A csomag tartalma eltérhet a képen látottaktól. A Meccano fenntartja magának a jogot, hogy bármikor felfüggeszse a [www.meccano.com](http://www.meccano.com) weboldal használatát. A felhívőteknek rendszeresen ellenőrizniük kell, hogy a játékon nincs-e sérülés, illetve nem jelent-e veszélyforrást. Ha igen, ki kell vonni a használatból. A gyermeknek játék közben felügyeletet igényelnek.

**RO.** Îndepărtați toate ambalajele înainte de utilizare. Păstrați aceste informații, adresele și numerele de telefon pentru consultare ulterioară. Conținutul poate fi diferit de imaginea din fotografii. Meccano își rezervă dreptul de a întrerupe utilizarea site-ului web [www.meccano.com](http://www.meccano.com) în orice moment. Această jucărie trebuie verificată periodic de un adult pentru a se asigura că nu există nicio deteriorare sau nicio pericol; dacă există, scoateți jucăria din uz. Copiii trebuie supravegheați în timp ce se joacă.

TM & © 2016 MECCANO for packaging, instructions and models built with this set.

© MECCANO is an exclusive trademark of MECCANO. Spin Master logo is a trademark of Spin Master Ltd. All rights reserved. / TM & © 2016 MECCANO pour l'emballage, les notices et modèles de ce coffret. © MECCANO est une marque de commerce exclusive de MECCANO. Le logo de Spin Master est une marque de commerce de Spin Master Ltd. Tous droits réservés.

- ⚠ Warning: CHOKING HAZARD – Small parts.
- ⚠ Attention ! RISQUE D'ETOUFFEMENT – Contient de petits éléments.
- ⚠ Advertencia: PELIGRO DE ASFIXIA – Contiene piezas pequeñas No conveniente para niños menores de 3 años.
- ⚠ Achtung: ERSTICKUNGSGEFAHR – Kleinteile.
- ⚠ Waarschuwing: VERSTIKKINGSGEVAAR – Kleine onderdelen.
- ⚠ Attenzione: RISCHIO DI SOFFOCAMENTO – Pezzi piccoli.
- ⚠ Aviso: PERIGO DE ASFIXIA – Peças pequenas.
- ⚠ Осторожно! ОПАСНОСТЬ УДУШЬЯ – Мелкие детали.
- ⚠ Uwaga! NIEBEZPIECZENSTWO ZADŁAWIENIA – Drobne elementy.
- ⚠ Upozornění: NEBEZPEČÍ UDUŠENÍ – Obsahuje malé části.
- ⚠ Varovanie: NEBEZPEČENSTVO UDUŠENIA – Obsahuje malé predmety.
- ⚠ Figeylem! FULLADÁSVEZÉLY – Apró alkatrészek.
- ⚠ Avertisment: PERICOL DE ASFIXIERE – Piese mici.



General Motors Trademarks used under license to Spin Master Ltd. Les marques de commerce de General Motors sont utilisées sous licence par Spin Master Ltd.

Edad Recomendada 10 Años en Adelante Juguete Importado por: Spin Master México, S.A. de C.V. Av. Insurgentes Sur No.1070 piso 8 Colonia Insurgentes San Borja Delegación Benito Juárez C.P. 03100, Ciudad de México. R.F.C. SMM050627V48 Atención al cliente: 55 4160 7947

Meets CPSC Safety Requirements.  
Conforme aux exigences de sécurité de la CPSC.  
Cumple con las normas de seguridad de la CPSC.

SPIN MASTER LTD., 450 FRONT STREET WEST, TORONTO, ON M5V 1B6 CANADA.  
Imported into EU by SPIN MASTER INTERNATIONAL, S.A.R.L.,  
16 AVENUE PASTEUR, L-2310, LUXEMBOURG. [www.spinmaster.com](http://www.spinmaster.com)  
Made in China / Fabriqué en Chine / Hecho en China



T91837\_0001\_20084599\_GML\_IB\_R2\_MEC\_Corvette\_CN\_S17

**UK – 0800 206 1191, [serviceuk@spinmaster.com](mailto:serviceuk@spinmaster.com)**  
**IRELAND – 1800 992 249**  
**FRANCE – 0800 909 150, [servicefr@spinmaster.com](mailto:servicefr@spinmaster.com)**  
**DEUTSCHLAND – 08000 0101 0222, [kundenservice@spinmaster.com](mailto:kundenservice@spinmaster.com)**  
**SCHWEIZ – 0800 561 350 • ÖSTERREICH – 0800 297 267**  
**NEDERLAND – 0800 022 3683, [klantenservice@spinmaster.com](mailto:klantenservice@spinmaster.com)**  
**BELGIË/BELGIQUE – 0800 77 688 • LUXEMBOURG – 800 2 8044**

**ITALIA – 800 788 532, [servizio@spinmaster.com](mailto:servizio@spinmaster.com)**  
**MÉXICO – 55 4160 7947, [servicio@spinmaster.com](mailto:servicio@spinmaster.com)**  
**POLSKA – 800080238, [poland@spinmaster.com](mailto:poland@spinmaster.com)**  
**ČESKÁ REPUBLIKA – 800550530, [czechrepublic@spinmaster.com](mailto:czechrepublic@spinmaster.com)**  
**SLOVENSKO – 0800232800, [slovakia@spinmaster.com](mailto:slovakia@spinmaster.com)**  
**MAGYARORSZÁG – 080 100 052, [hungary@spinmaster.com](mailto:hungary@spinmaster.com)**  
**ROMÂNIA – 0800400015, [romania@spinmaster.com](mailto:romania@spinmaster.com)**

**NORTH AMERICA • AMÉRIQUE DU NORD 1-800-622-8339, [CUSTOMERCARE@SPINMASTER.COM](mailto:CUSTOMERCARE@SPINMASTER.COM)**

**WWW.SPINMASTER.COM**

