

MECCANO
MAKER SYSTEM

**EMPIRE STATE
BUILDING
ARC DE TRIOMPHE**

15306



2ⁱⁿ1

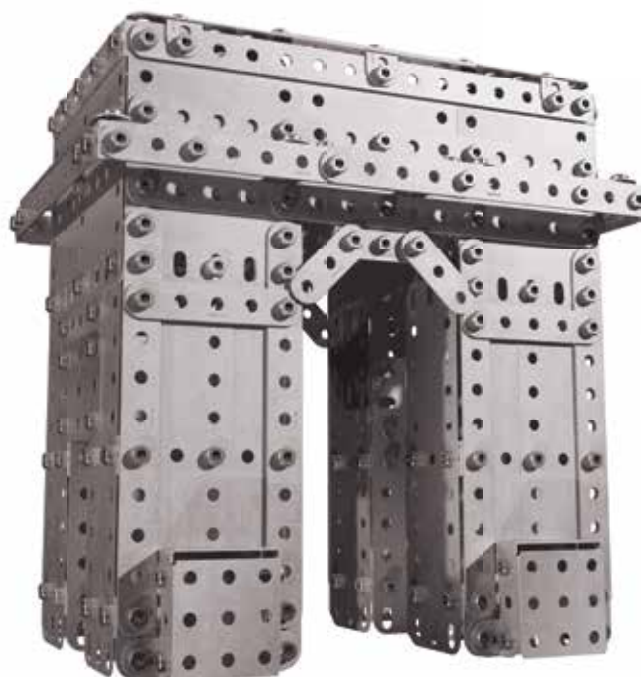

4 x AA 1.5V

BATTERIES NOT INCLUDED / PILAS NON
FOURNIES / PILAS NO INCLUIDAS /
BATTERIEN NICHT ENTHALTEN / BATTERIJEN
NIET INBEGREPEN / BATTERIE NON INCLUSE /
BATERIAS NÃO INCLUSAS /
ЭЛЕМЕНТЫ ПИТАНИЯ НЕ ВХОДЯТ В КОМПЛЕКТ

 **12+**

**Instructions
Notice de
montage
Instrucciones de
construcción
Bauanleitung
Bouwinstructie
Istruzioni
Instruções
Инструкции**



NEW TOOLS / NOUVEAUX OUTILS

NUEVAS HERRAMIENTAS / NEUE WERKZEUGE

NIEUW GEREEDSCHAP / NUOVI ATTREZZI

NOVAS FERRAMENTAS / НОВЫЕ ИНСТРУМЕНТЫ

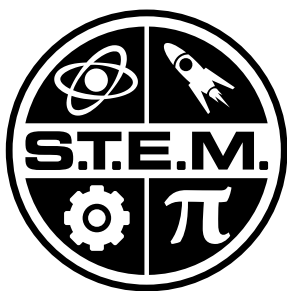
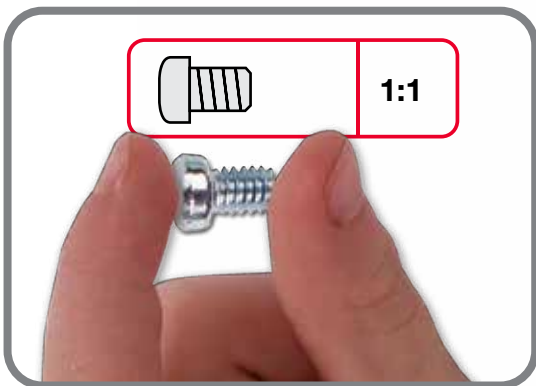
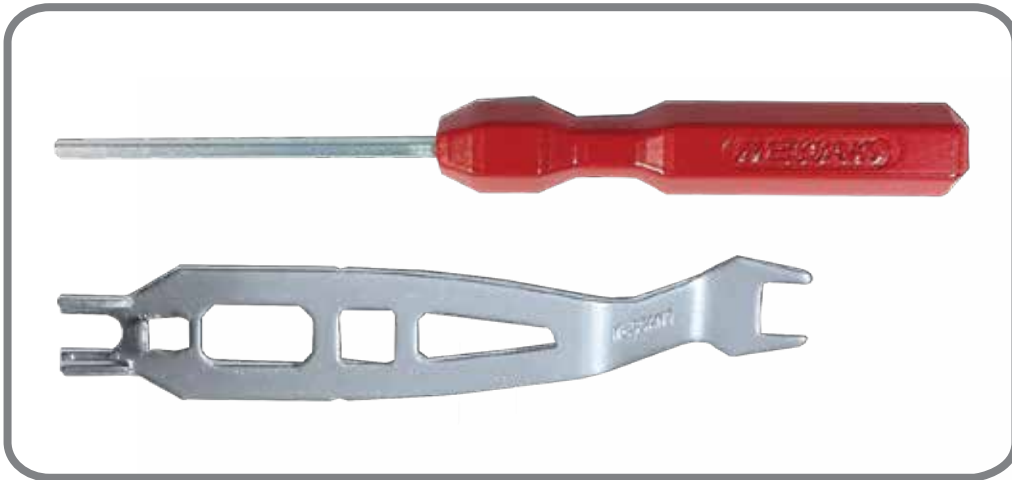

GB. For information on how this product supports today's STEM curriculum, visit www.meccano.com.

F. Pour découvrir l'intérêt pédagogique de ce produit dans le cadre des matières STEM, rendez-vous sur www.meccano.com.

E. Para mayor información sobre cómo este producto respalda las materias STEM visita: www.meccano.com.

D. Für Informationen wie dieses Produkt den technisch-mathematischen Lehrplan (STEM) unterstützt, besuchen Sie bitte www.meccano.com.

NL. Ga naar www.meccano.com voor meer informatie over hoe dit product het huidige STEM-curriculum ondersteunt.

I. Per informazioni su come questo prodotto contribuisce ad aiutare i ragazzi nelle materie STEM "scientifiche e tecniche", visitare il sito www.meccano.com.

P. Para informações sobre a compatibilidade deste produto com os programas atuais STEM, acesse www.meccano.com.

R. Информация о том, как с помощью этого продукта можно повысить эффективность процесса изучения дисциплин STEM, представлена на сайте www.meccano.com.

TABLE OF CONTENTS/SOMMAIRE

ÍNDICE / INHALTSVERZEICHNIS / INHOUD / INDICE / ÍNDICE / СОДЕРЖАНИЕ

EMPIRE STATE BUILDING

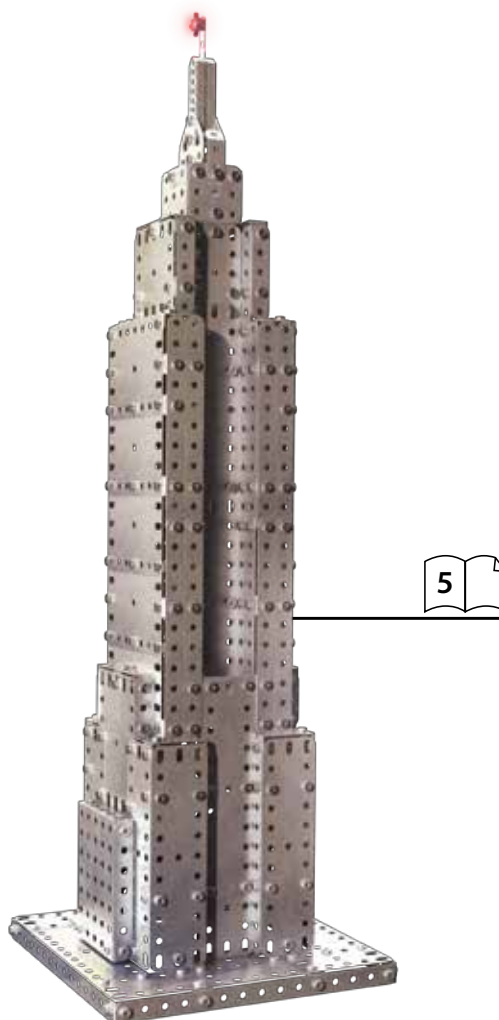

GB. Content: 958 parts, 2 real tools and 1 instruction sheet for 1 model.
F. Contenu : 958 pièces, 2 vrais outils et 1 notice de montage pour 1 modèle.
E. Contenido: 958 piezas, 2 herramientas reales y 1 guía de instrucciones para 1 modelo.
D. Inhalt: 958 Teile, 2 echte Werkzeuge und 1 Bauanleitung für 1 Modell.

NL. Inhoud: 958 onderdelen, 2 stuks gereedschap en 1 bouw instructie voor 1 model.
I. Contenuto: 958 pezzi, 2 attrezzi e 1 guida per l'uso per 1 modello.
P. Conteúdo: 958 peças, 2 ferramentas reais e 1 folha de instruções para 1 modelo.
R. В коробке: 958 деталей, 2 настоящих инструмента и 1 инструкция по сборке 1 модели.

ARC DE TRIOMPHE

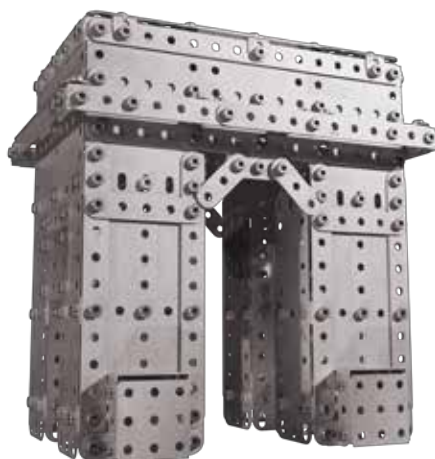

GB. Only one model can be built at a time.
F. Les pièces fournies ne permettent de monter qu'un seul modèle à la fois.
E. Solo es posible construir un modelo a la vez.
D. Jeweils nur eins der Modelle baubar.
NL. Er kan maar een model tegelijk worden gebouwd.
I. Permette di realizzare un solo modello per volta.
P. Só é possível montar um modelo de cada vez.
R. Одновременно можно построить только одну модель.

GB. Building instructions for model #2 are available at www.meccano.com.
F. La notice de montage du modèle 2 est disponible sur www.meccano.com.
E. Hay instrucciones de construcción disponibles para el modelo 2 en www.meccano.com.
D. Die Bauanleitung für Modell Nr. 2 ist auf www.meccano.com zu finden.

NL. Bouw instructies voor model #2 zijn verkrijgbaar op www.meccano.com.
I. Le istruzioni di montaggio del modello 2 sono disponibili alla pagina www.meccano.com.
P. As instruções de montagem para o modelo 2 estão disponíveis em www.meccano.com.
R. Инструкции по сборке модели №2 можно найти на сайте www.meccano.com.

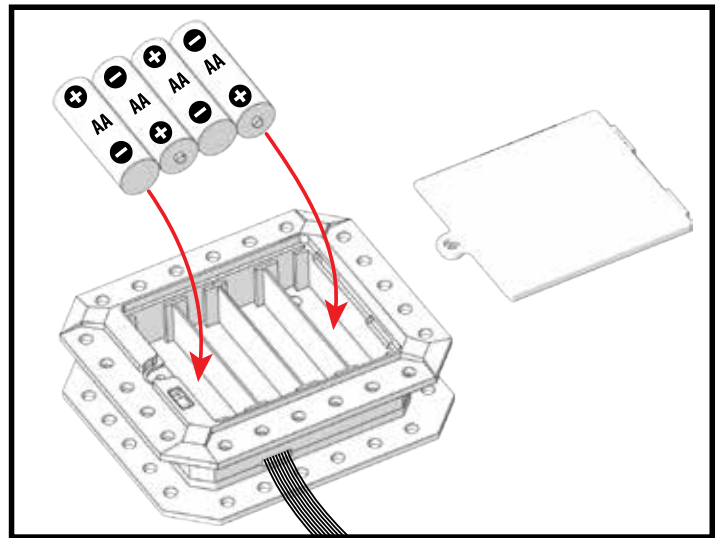
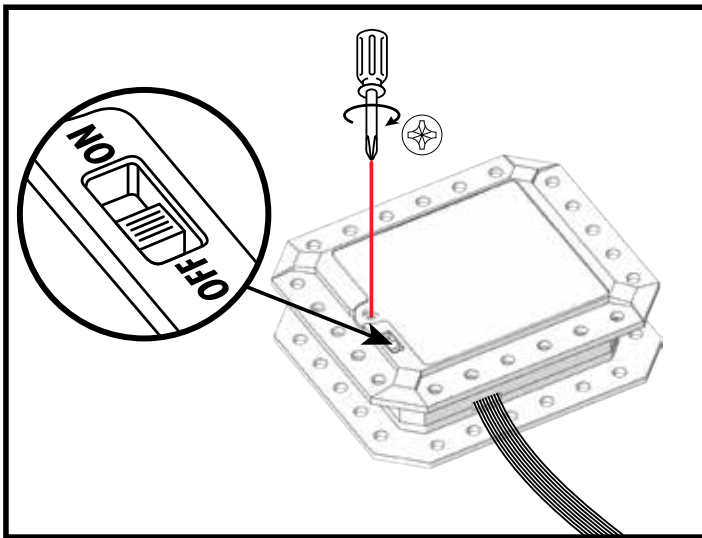

GB 1. Open the battery door with a screwdriver.

2. If used batteries are present, remove these batteries from the unit by pulling up on one end of each battery. DO NOT remove or install batteries using sharp or metal tools.
3. Install new batteries as shown in the polarity diagram (+/-) inside the battery compartment.
4. Replace battery door securely.
5. Check your local laws and regulations for correct recycling and/or battery disposal.

F 1. Ouvrir le compartiment des piles à l'aide d'un tournevis.

2. S'il contient des piles usagées, les retirer en les soulevant par l'une des extrémités. NE PAS utiliser d'objet coupant ou métallique pour retirer ou insérer des piles.
3. Insérer les nouvelles piles en respectant le schéma de polarité (+/-) dans le compartiment des piles.
4. Bien refermer le compartiment des piles.
5. Recycler ou jeter les piles usagées conformément à la législation locale.

E 1. Abra la tapa del compartimento de las pilas con un destornillador.

2. Si las pilas están gastadas, tire hacia arriba de uno de sus extremos para extraerlas. NO utilice herramientas metálicas o puntiagudas para instalar o extraer las pilas.
3. Instale las pilas nuevas como se muestra en el esquema de polaridad (+/-) dentro del compartimento de las pilas.
4. Vuelva a colocar la tapa del compartimento de las pilas.
5. Consulte la normativa local relativa al reciclaje y desecho de las pilas.

D 1. Batteriefachabdeckung mit einem Schraubendreher öffnen.

2. Wenn sich gebrauchte Batterien darin befinden, diese einzeln herausziehen. Batterien NICHT mit scharfen oder metallenen Gegenständen entfernen oder einlegen.
3. Neue Batterien unter Beachtung des Polaritätsdiagramms (+/-) in das Batteriefach einlegen.
4. Batteriefachabdeckung wieder anbringen.
5. Örtliche Gesetze und Bestimmungen für das Recycling bzw. die Entsorgung von Altbatterien beachten.

NL 1. Open het batterijdeksel met een schroevendraaier.

2. Verwijder eventueel gebruikte aanwezige batterijen uit de unit door één kant van elke batterij omhoog te trekken. Verwijder of plaats batterijen NIET met behulp van scherpe of metalen voorwerpen.
3. Plaats de nieuwe batterijen zoals weergegeven op het polariteitsdiagram (+/-) aan de binnenkant van het batterijvak.
4. Sluit het vak af met het batterijdeksel.
5. Lees de plaatselijke voorschriften en regelgeving om de batterijen op de juiste wijze te recyclen of af te voeren.

I 1. Aprire lo scomparto pile con un cacciavite.

2. Se sono presenti pile usate, rimuoverle dall'unità sollevandole da un'estremità. NON usare oggetti metallici o appuntiti per rimuovere o installare le pile.
3. Inserire le nuove pile seguendo il diagramma della polarità (+/-) all'interno dello scomparto pile.
4. Riporre saldamente lo sportello dello scomparto pile.
5. Eliminare e/o riciclare le pile secondo quanto previsto dalle normative locali vigenti.

P 1. Abra a tampa do compartimento de pilhas com uma chave de fenda.

2. Se houver pilhas usadas, retire-as da unidade individualmente, puxando pela extremidade de cada uma. NÃO retire ou coloque pilhas com qualquer acessório pontiagudo ou metálico.
3. Instale pilhas novas seguindo o diagrama de polaridade (+/-) dentro do compartimento de pilhas.
4. Coloque de novo a porta do compartimento com cuidado.
5. Consulte as leis, as normas e os regulamentos locais de reciclagem e/ou descarte de pilhas e baterias.

R 1. Откройте крышку отсека элементов питания с помощью отвертки.

2. Извлеките старые или истощенные элементы питания из отсека (при их наличии), подняв каждый элемент питания за край. Запрещается извлекать или устанавливать батареи с помощью острых или металлических предметов.
3. Установите новые элементы питания внутри отсека, соблюдая полярность (+/-).
4. Надежно закройте крышку отсека.
5. Ознакомьтесь с законами и нормативами вашей страны, установленными в отношении правил переработки и/или утилизации элементов питания.



1

	x2
	x2
	x2 5,8 mm 15/64"
	x2

	1:1
--	------------

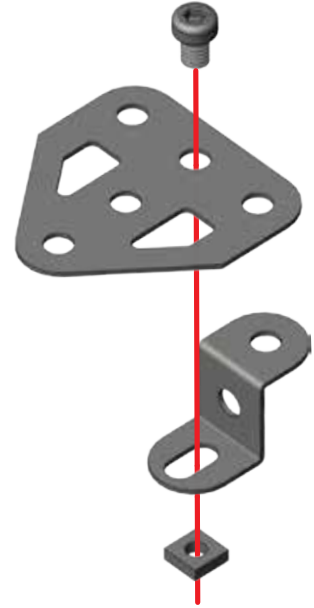

2 ①+

	x1
	x2
	x2 19 mm 3/4"
	x2

	1:1
--	------------

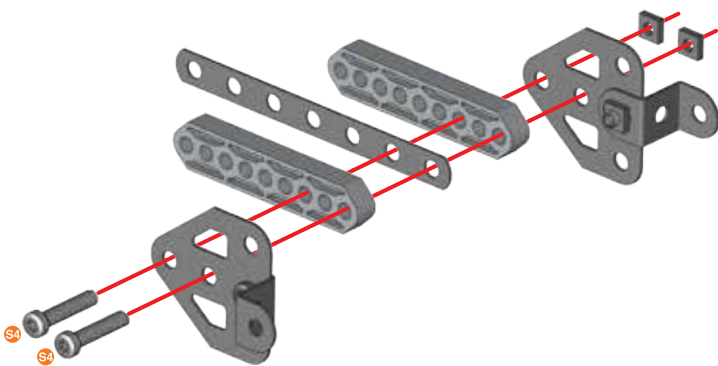

3

	x2
	x2 5,8 mm 15/64"
	x2

	1:1
--	------------

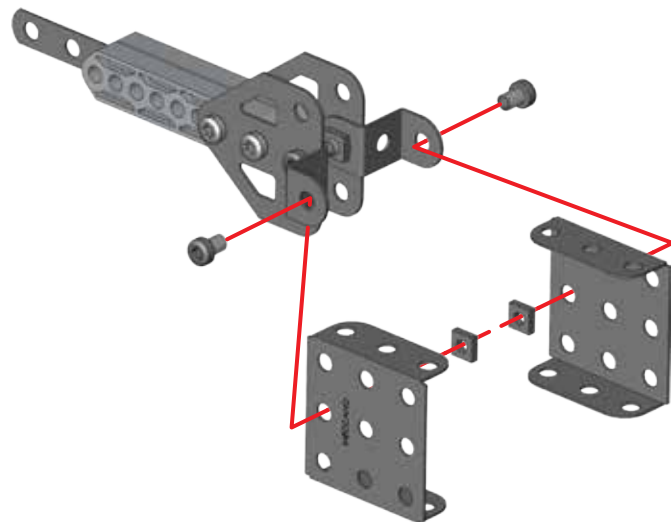

4

	x2
	x2
	x2
	x2

	S1	1:1
--	----	-----

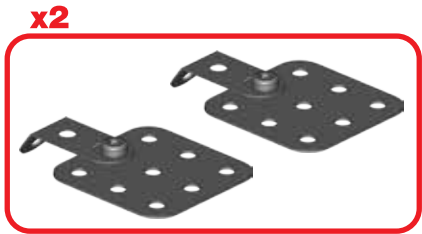
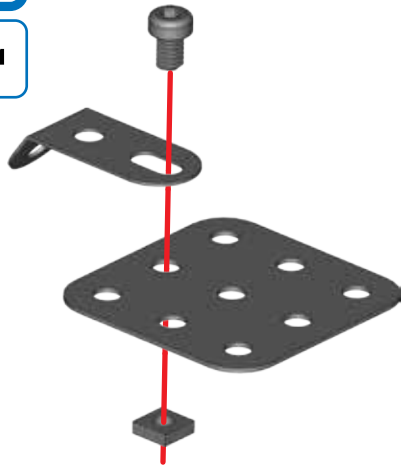

5

3 + 4 +

	x1
	x1
	x2
	x2

	S1	1:1
--	----	-----

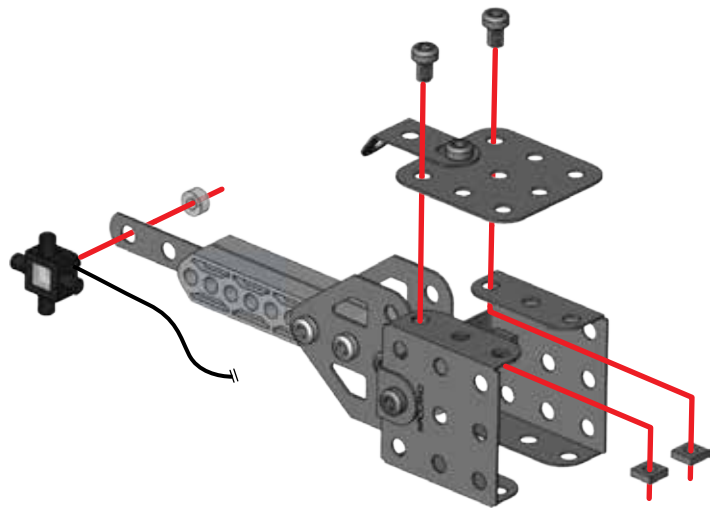

6

4 + 5 +

	x2
	x2

	S1	1:1
--	----	-----

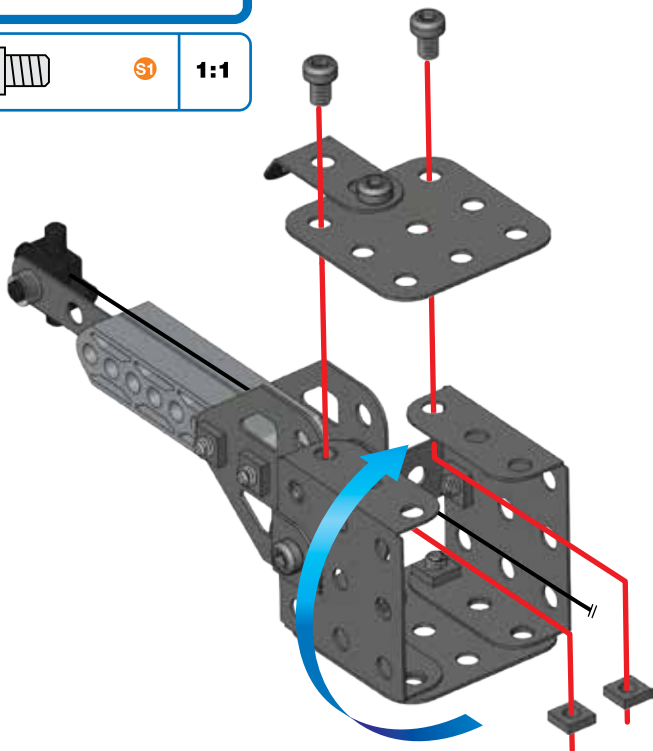



7

	x2
	x2
	x2

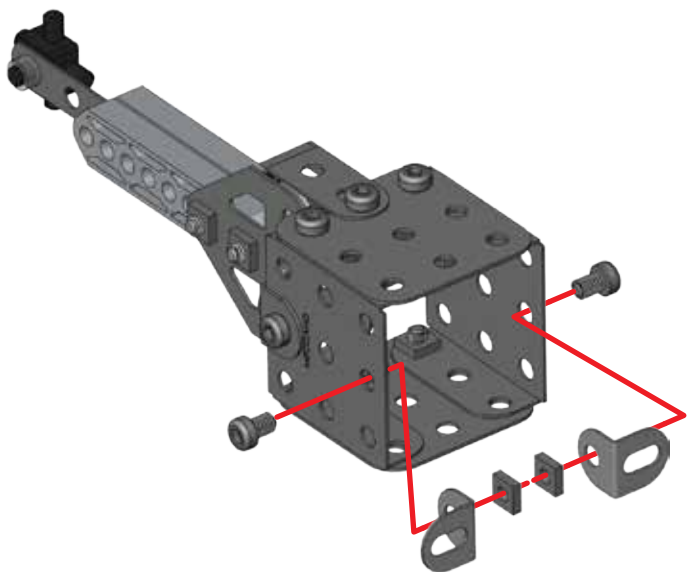
	S1	1:1
--	----	-----





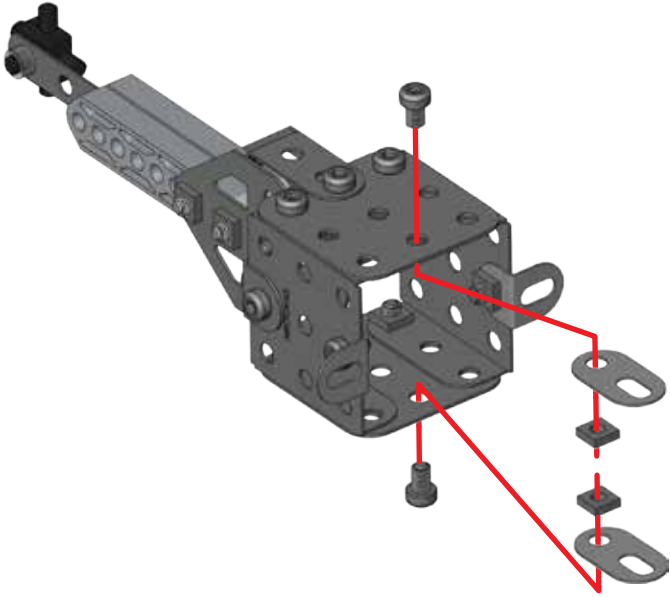

8

-  **x2**
-  **x2**
-  **x2**

-  **S1** **1:1**





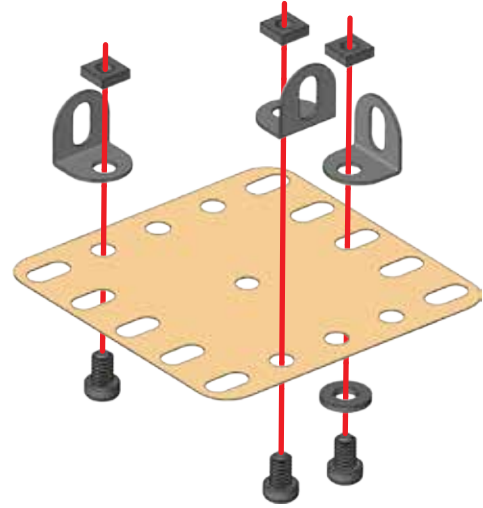

9

-  **x1**
-  **x3**
-  **x3**
-  **x3**
-  **x1**

-  **S1** **1:1**





10

-  **x1**
-  **x1**
-  **x1**
-  **x1**

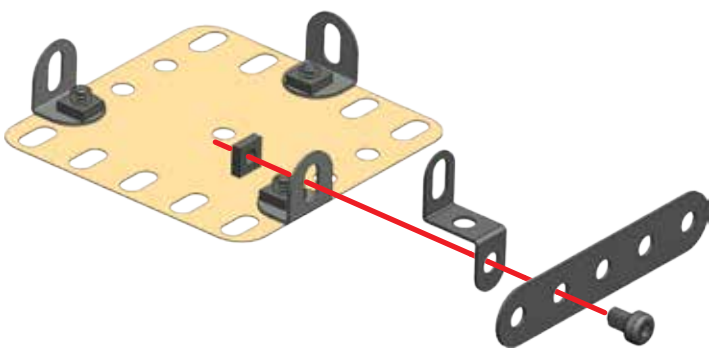
-  **S1** **1:1**



11

-  **x1**
-  **x1**
-  **x1**

-  **S1** **1:1**

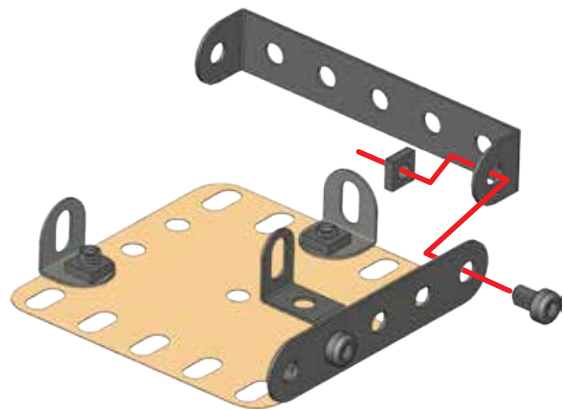

12

	x1
	x1
	x2
	x2

	S1	1:1
--	----	-----

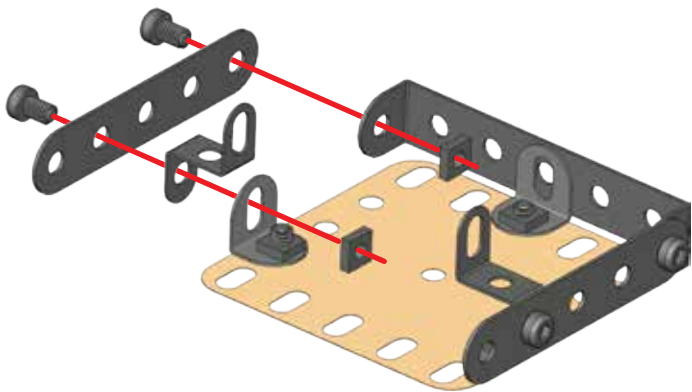

13

	x2
	x2
	x2

	S1	1:1
--	----	-----

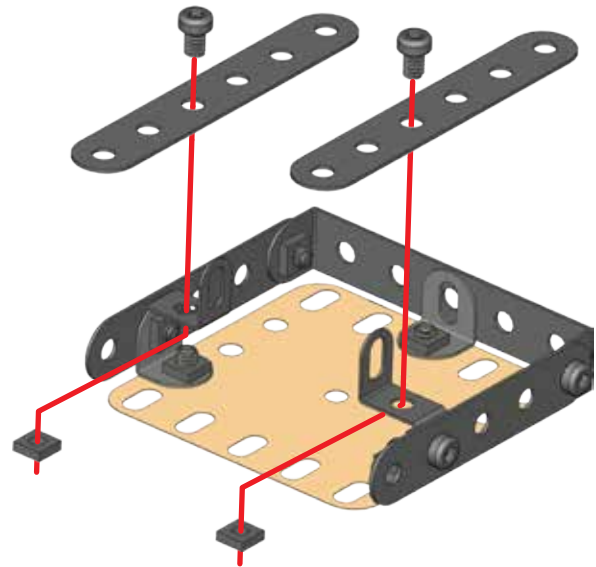

14

	x2
	x2
	x2

	S1	1:1
--	----	-----

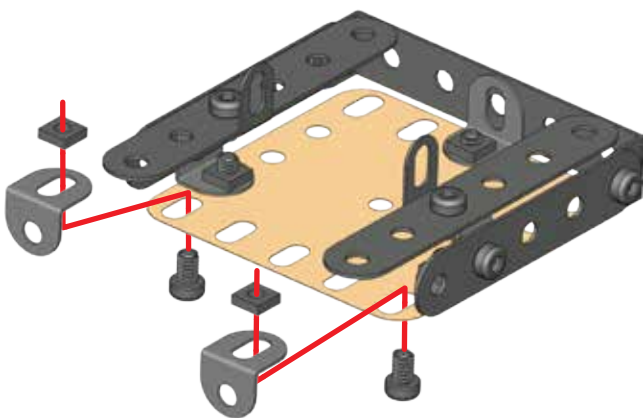

15

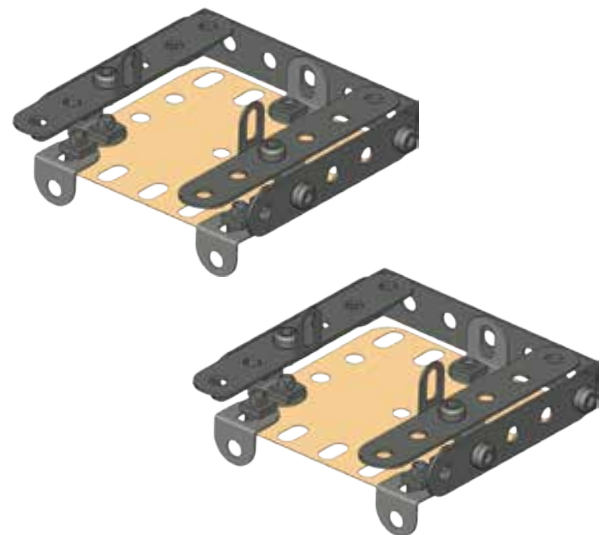

(9) ~ (14)

2x



16

8 + 15 +

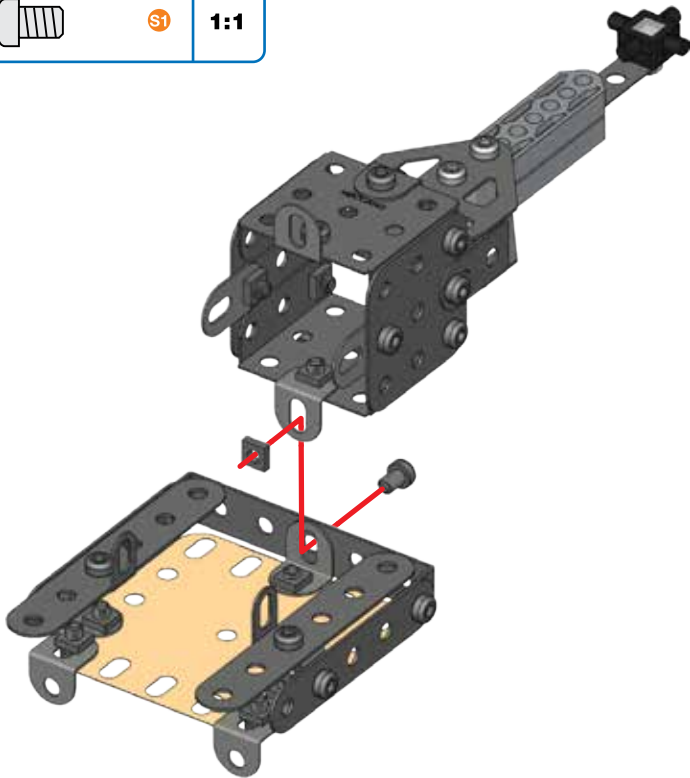

	S1 5,8 mm	x1
		x1

	S1	1:1
---	----	-----



17



15 + 16 +

	S1 5,8 mm	x1
		x1

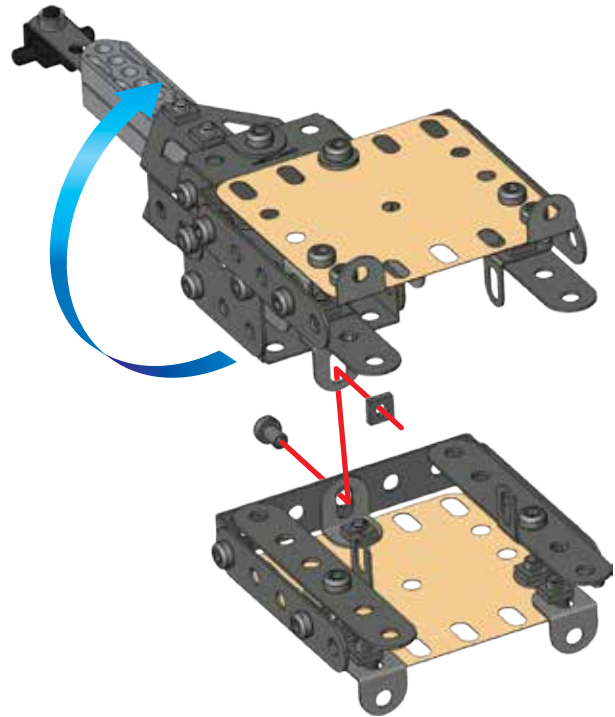
	S1	1:1
--	----	-----





18

		x1
	S1 5,8 mm	x3
		x3

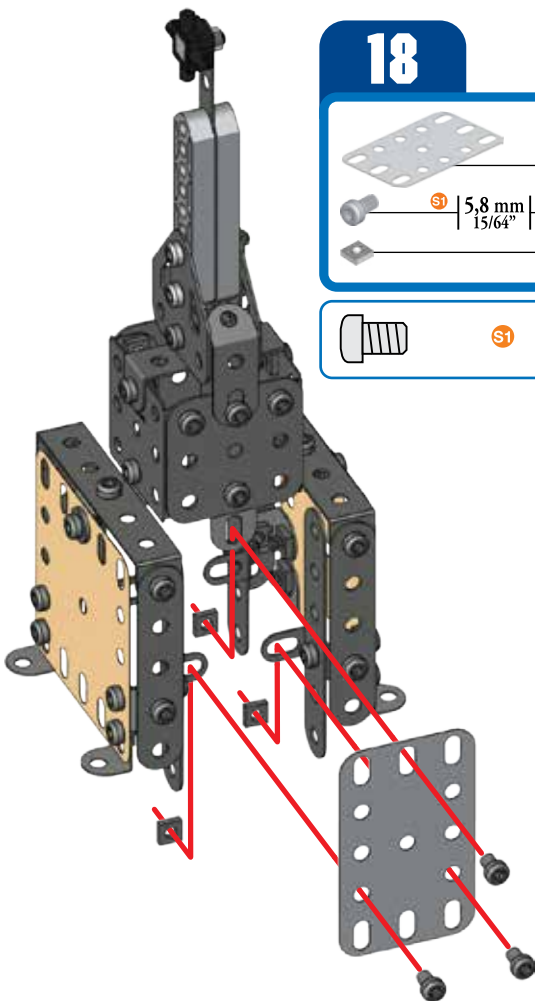
	S1	1:1
---	----	-----





19

		x1
	S1 5,8 mm	x3
		x3

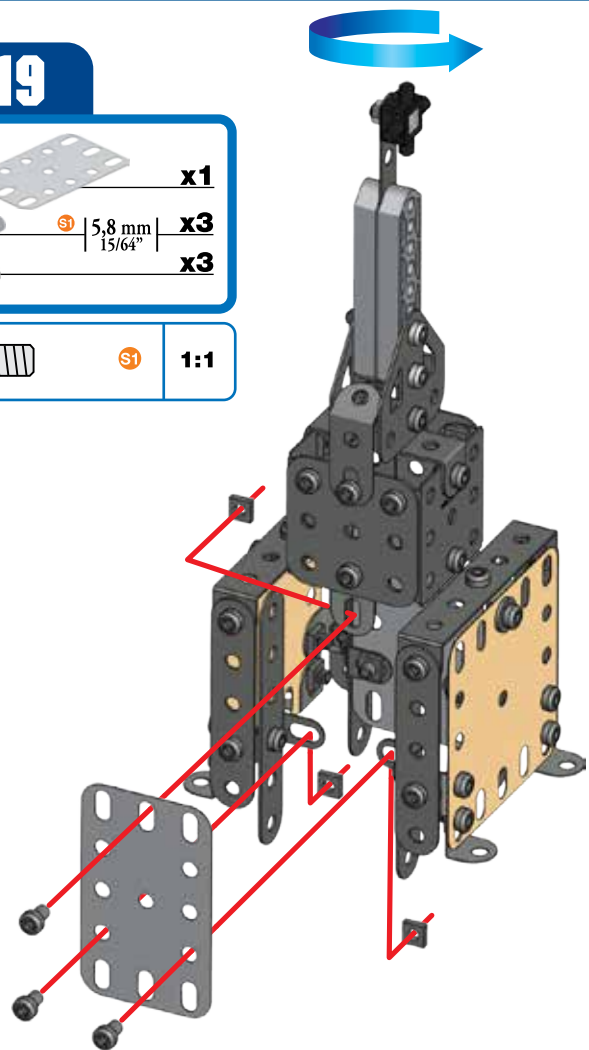
	S1	1:1
--	----	-----

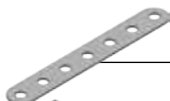

20

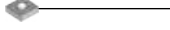
-  **x2**
-  **x4**
-  **x4**
-  **x4**

-  **S1** **1:1**

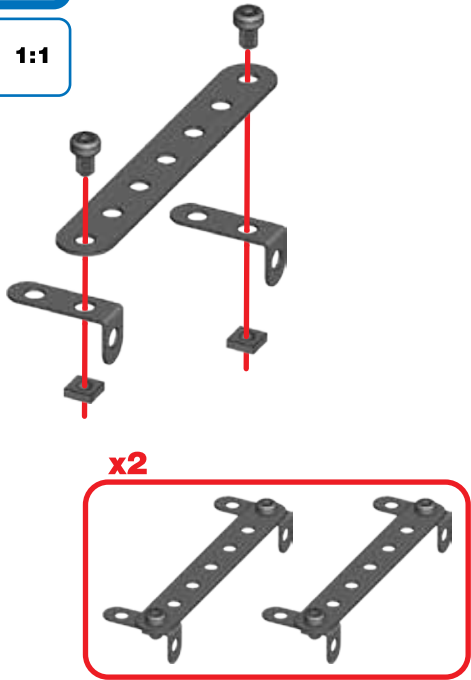

21

19 + 20 +

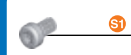
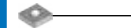

-  **S1** | 5,8 mm | **x2**
-  **x2**

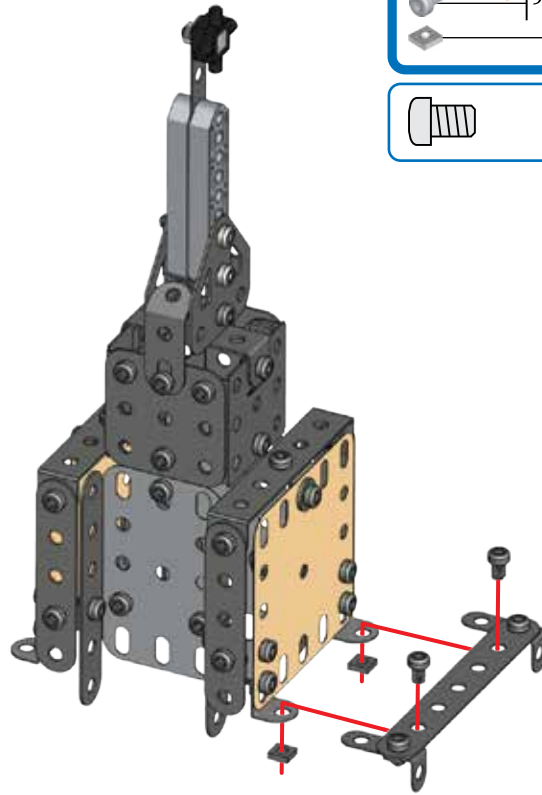
-  **S1** **1:1**



22

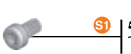

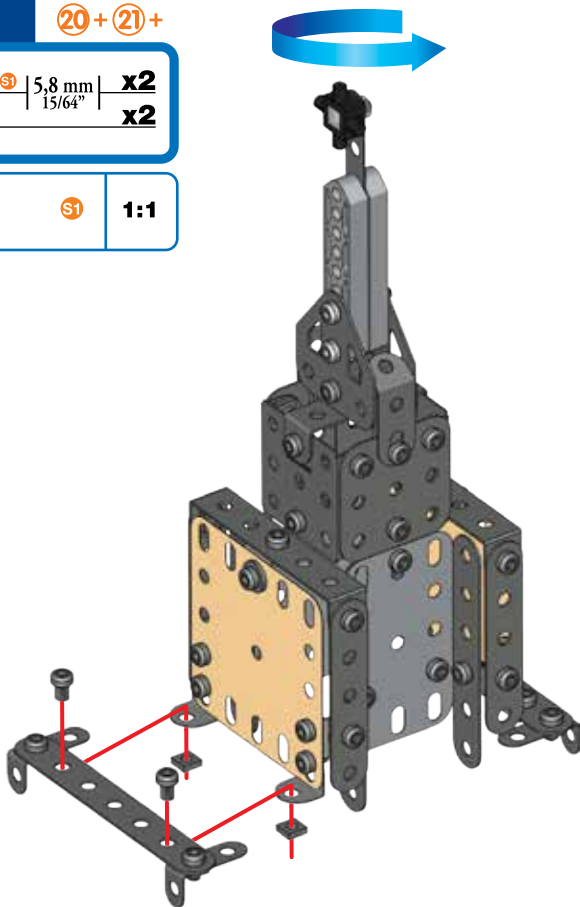

20 + 21 +

-  **S1** | 5,8 mm | **x2**
-  **x2**

-  **S1** **1:1**

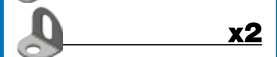

23

-  **x1**
-  **x2**
-  **x2**
-  **S1** | 5,8 mm | **x2**
-  **x2**

-  **S1** **1:1**

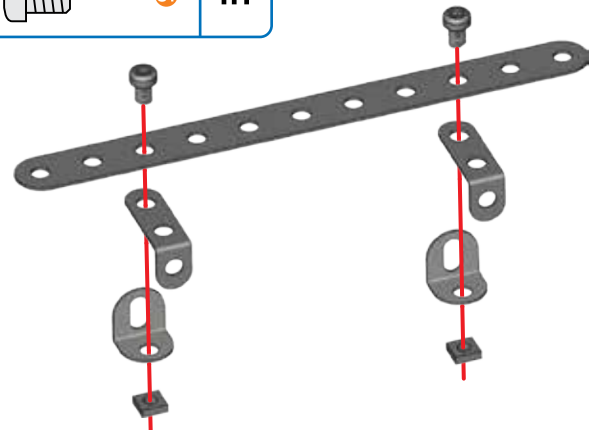

24

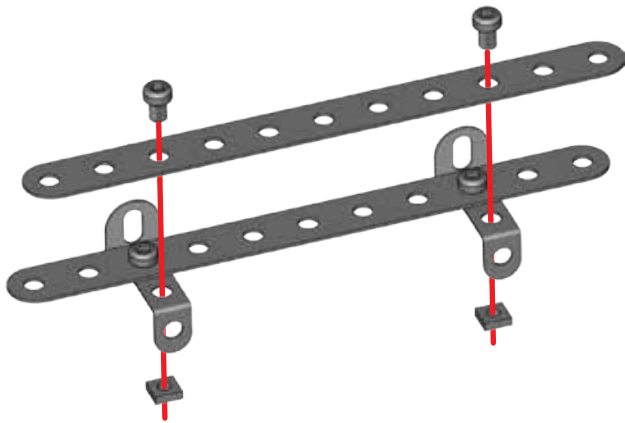
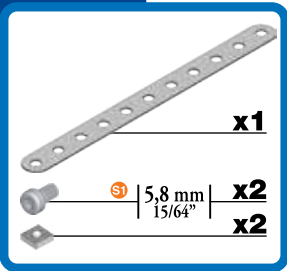

25

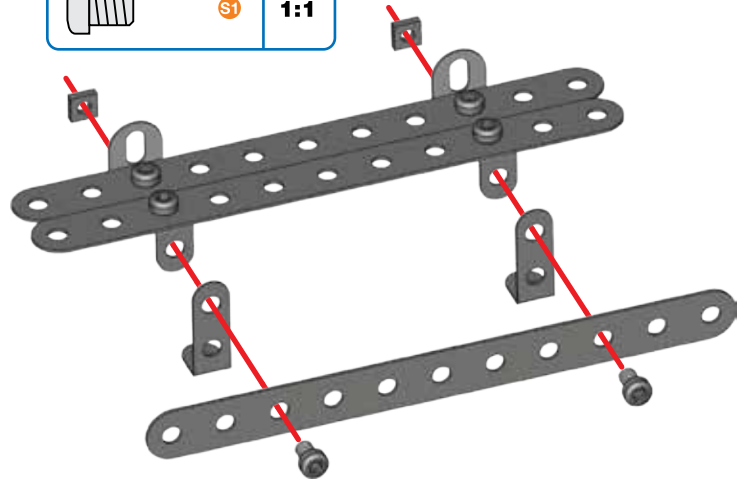
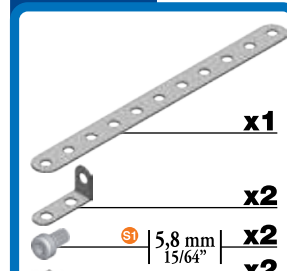

26

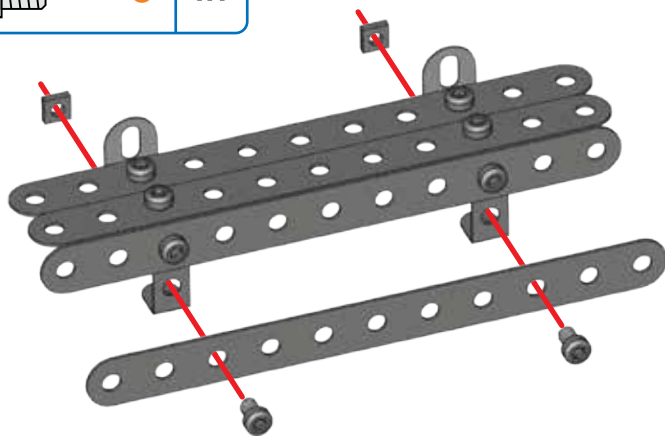
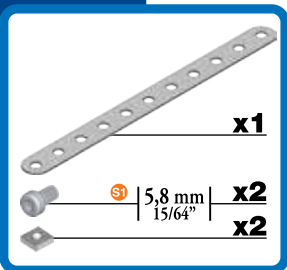

27



4x

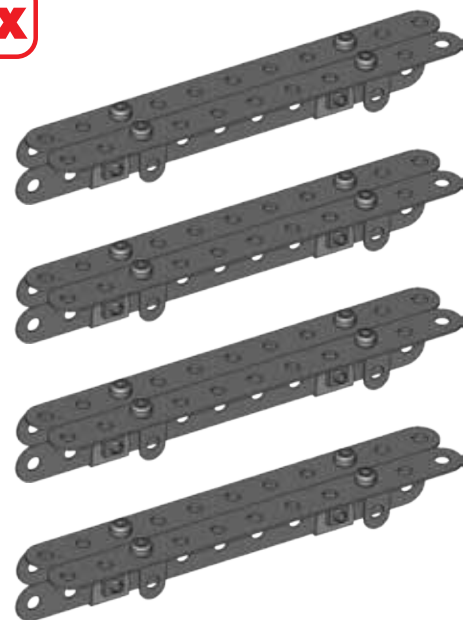

28

27+

- x2
- x2
- x2

- S1 1:1

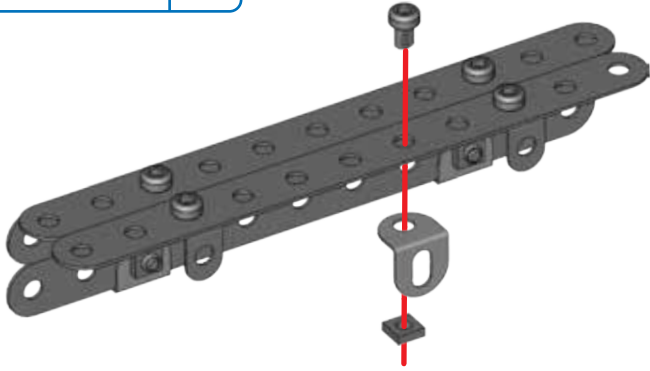

x2

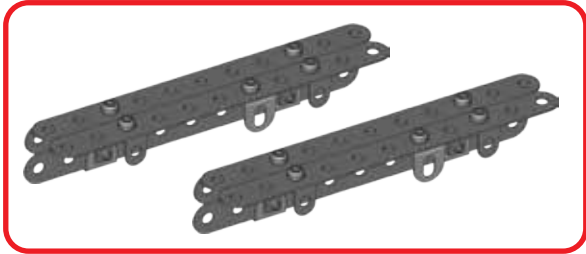

29

27+

- x2
- x2
- x2

- S1 1:1

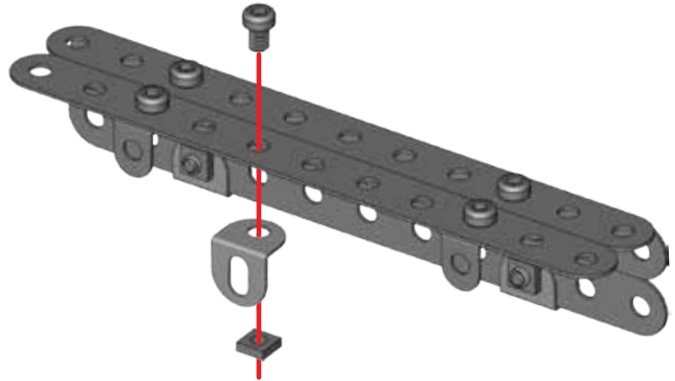

x2

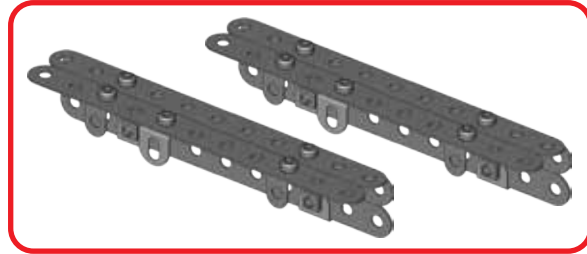

30

22+ 28+

- x1
- x1

- S1 1:1

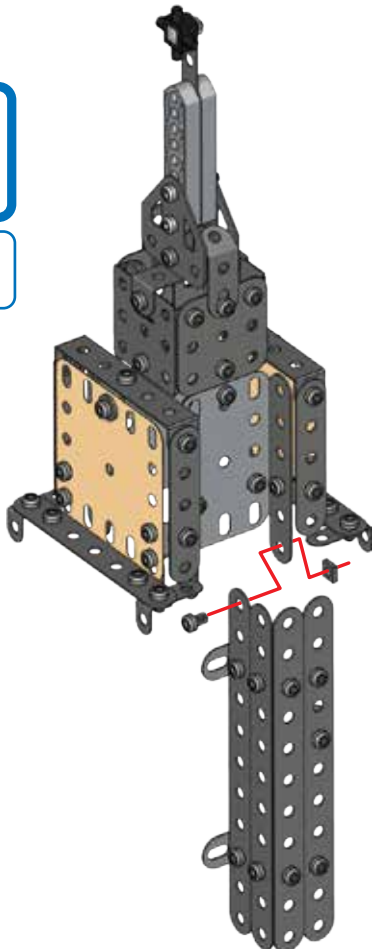

31



29+ 30+

- x1
- x1

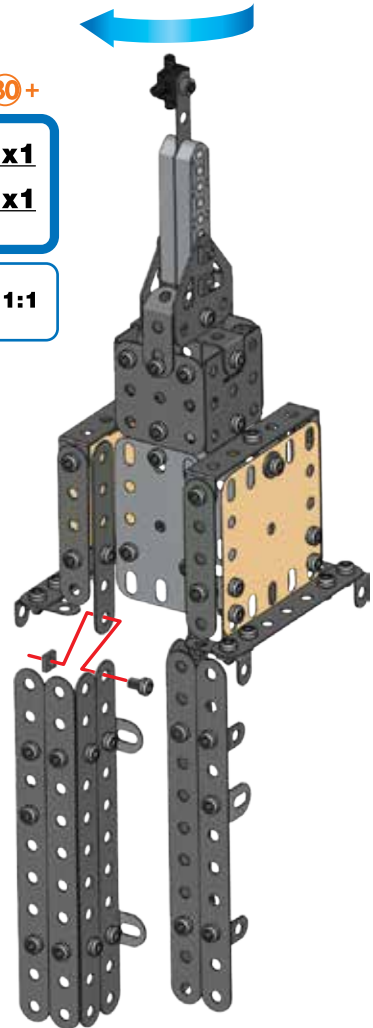
- S1 1:1





32 (28 + 31) +

	5,8 mm	x1
	15/64"	x1

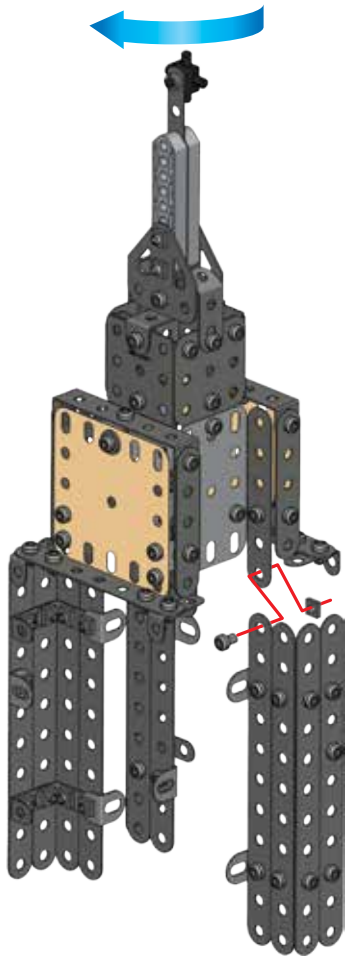
	S1	1:1
---	----	-----



33 (29 + 32) +

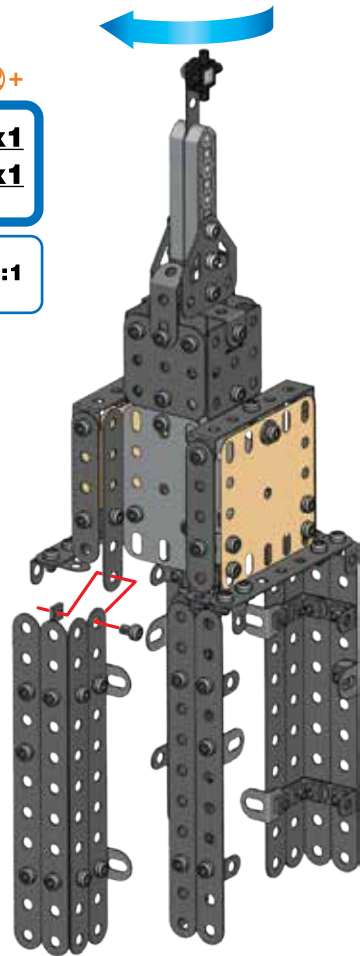

	5,8 mm	x1
	15/64"	x1

	S1	1:1
---	----	-----

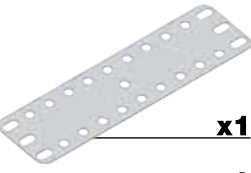

34

	x1
---	----

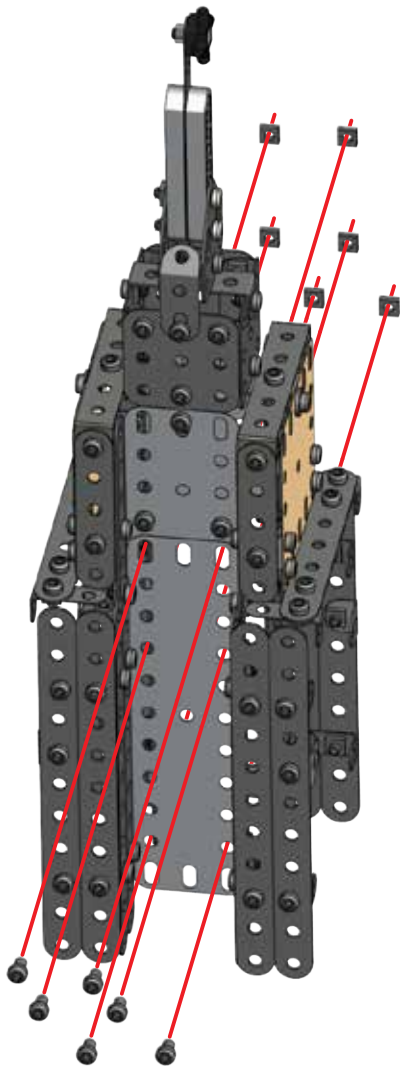

	5,8 mm	x6
	15/64"	x6

	S1	1:1
---	----	-----

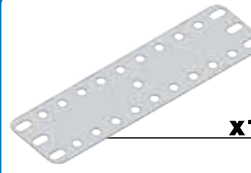

35

	x1
--	----

	5,8 mm	x6
	15/64"	x6

	S1	1:1
---	----	-----

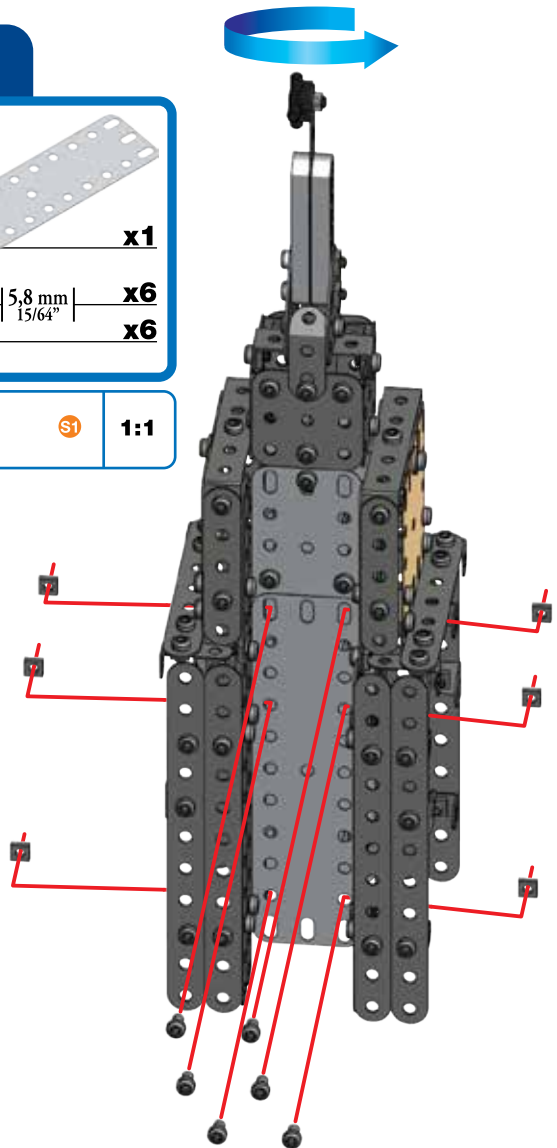

36

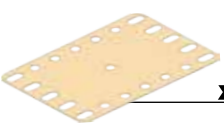
 **x1**

 **x4**
 5,8 mm
 15/64"

 **x4**

 **S1** **1:1**

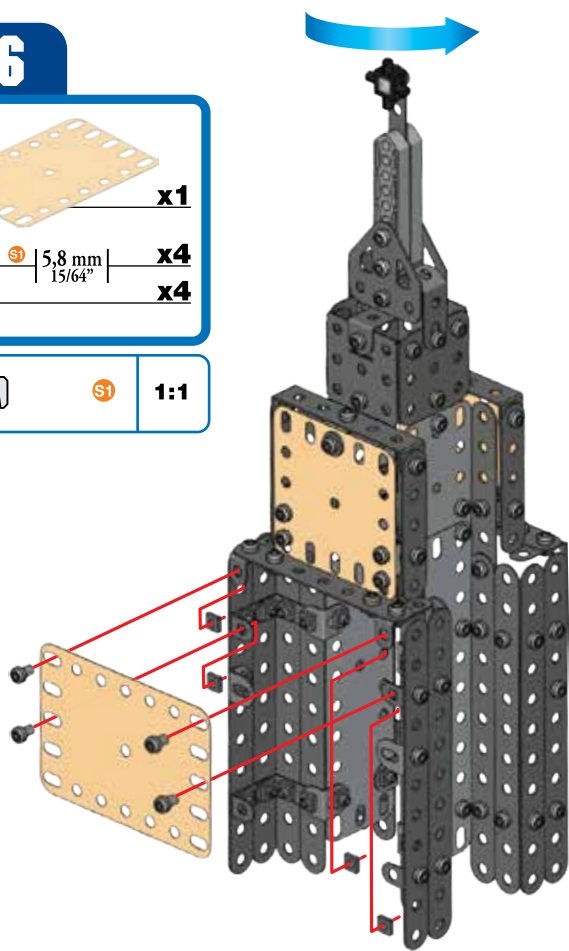

37

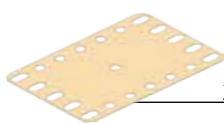
 **x1**

 **x3**
 5,8 mm
 15/64"

 **x3**

 **S1** **1:1**

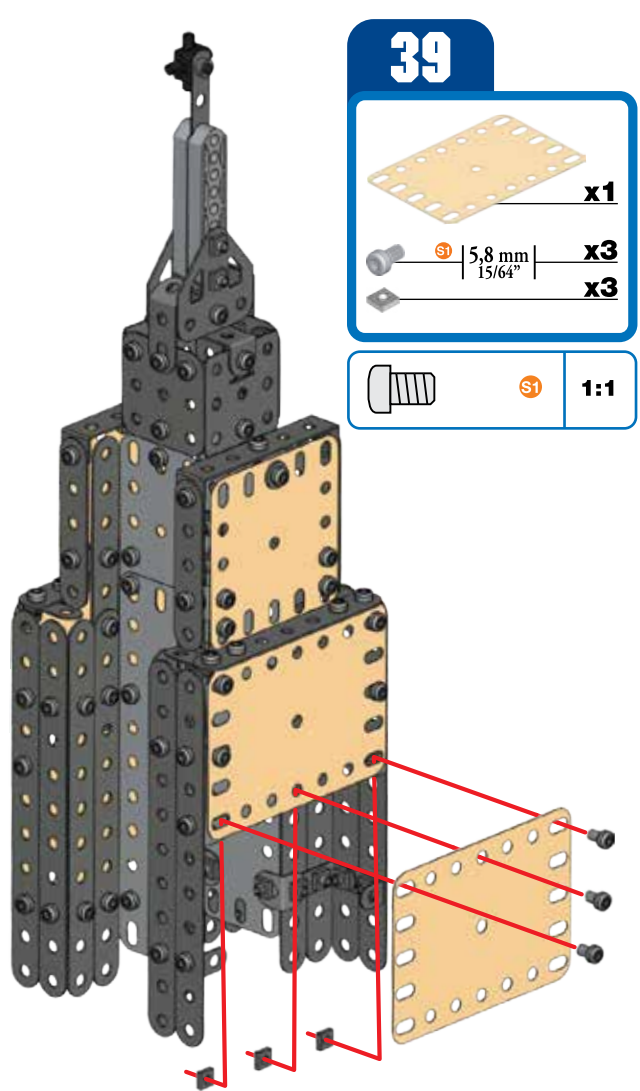
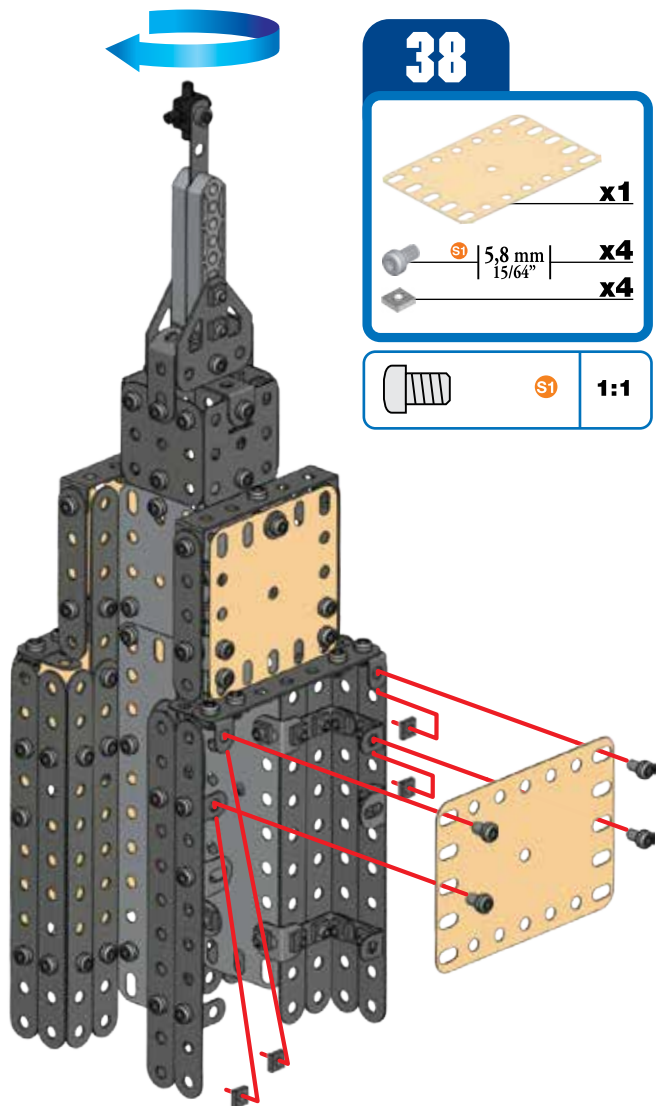
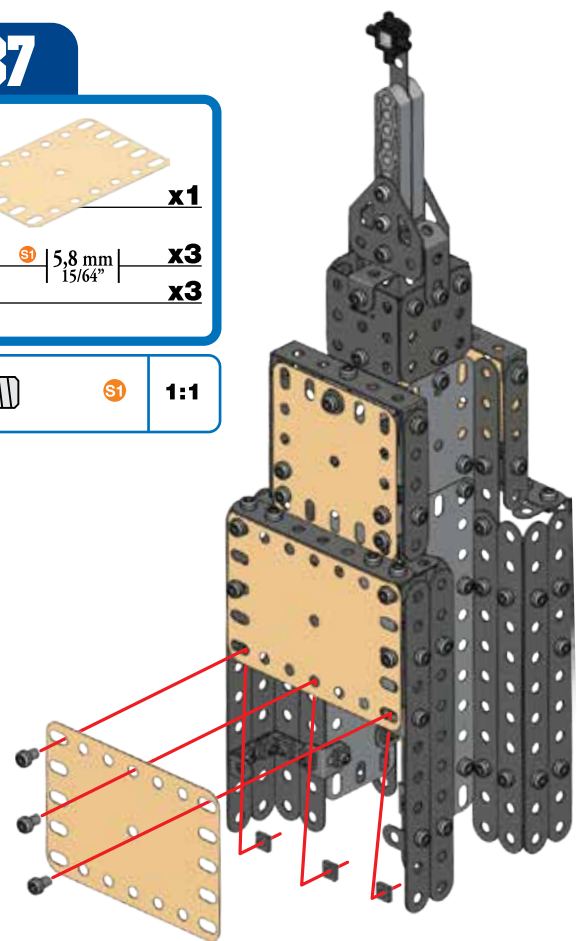

40

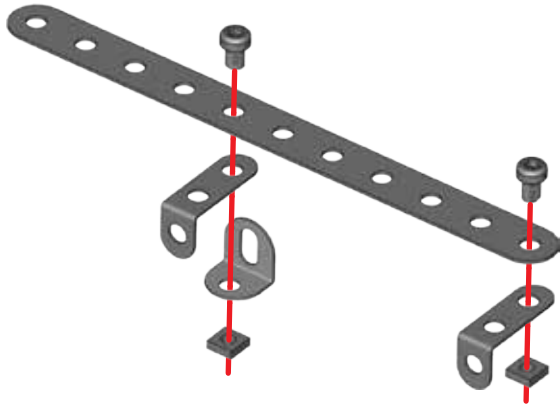
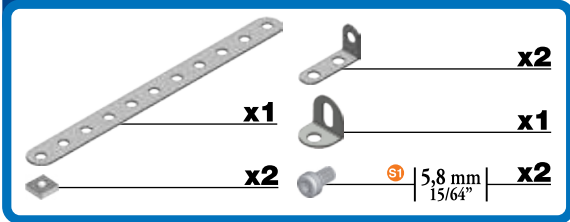

41

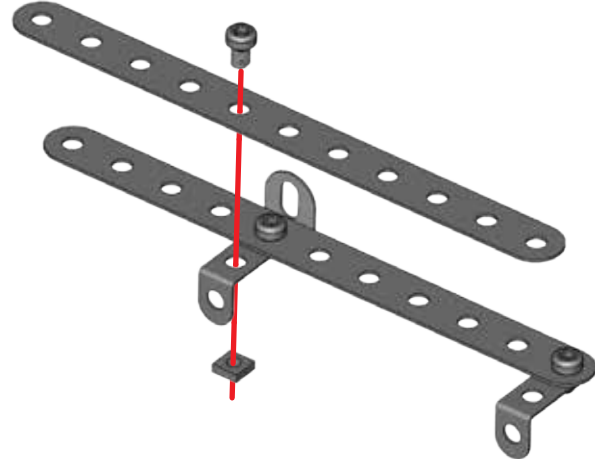
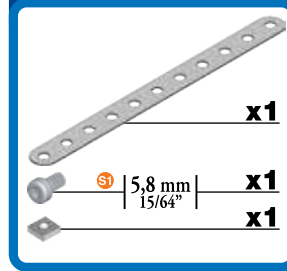

42

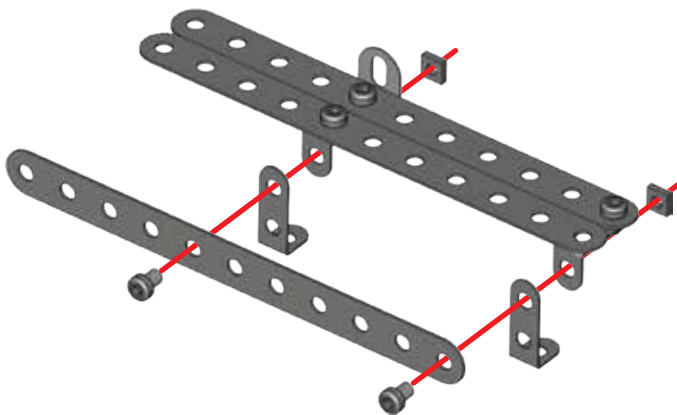
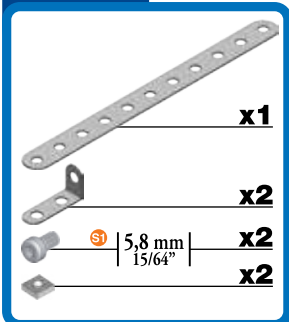

43

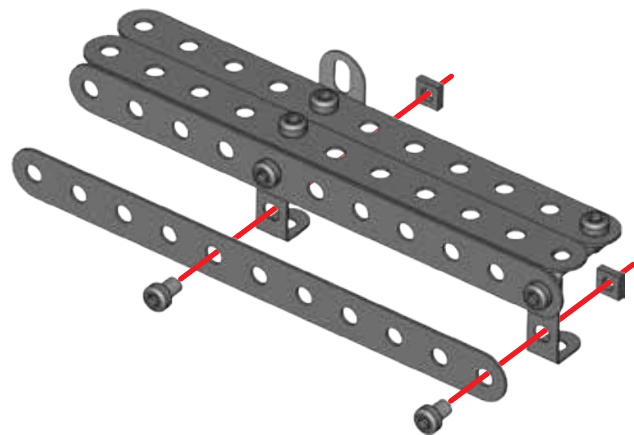
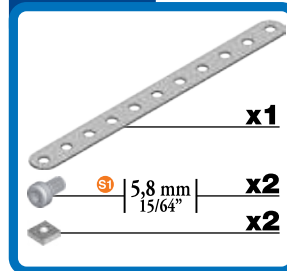

44



2x



45

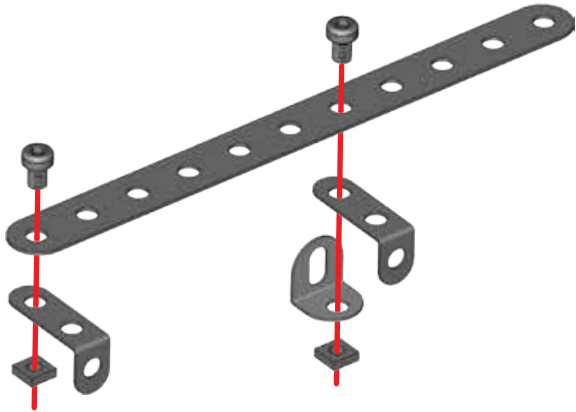
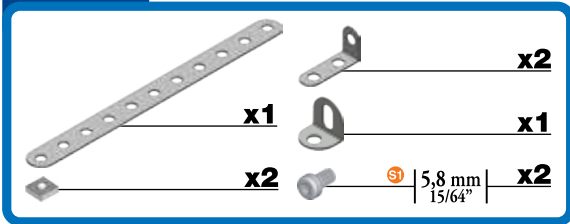

46

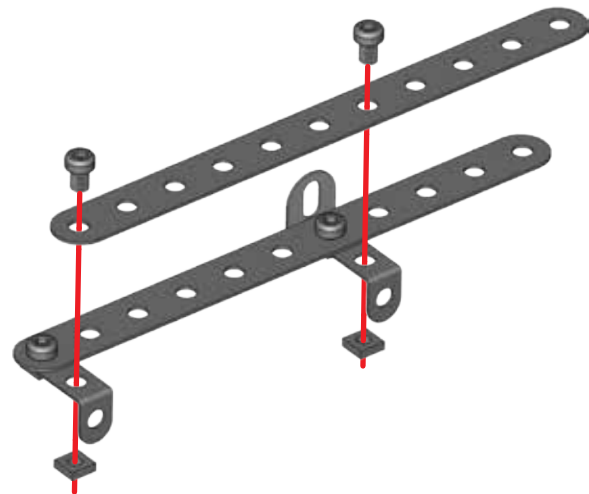
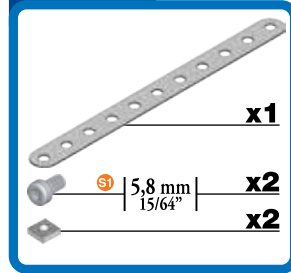

47

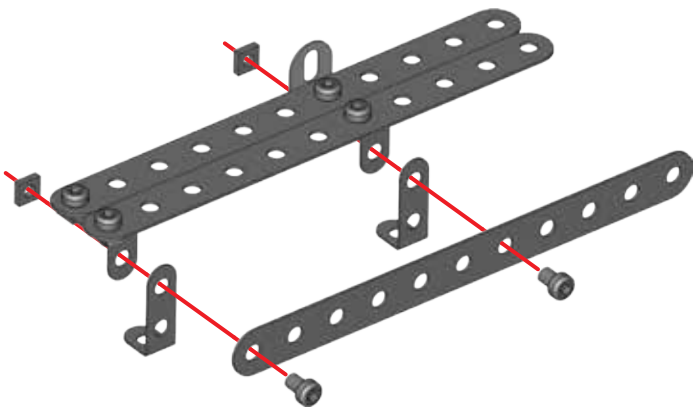
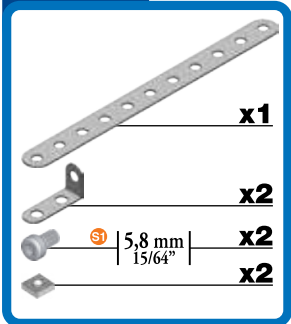

48

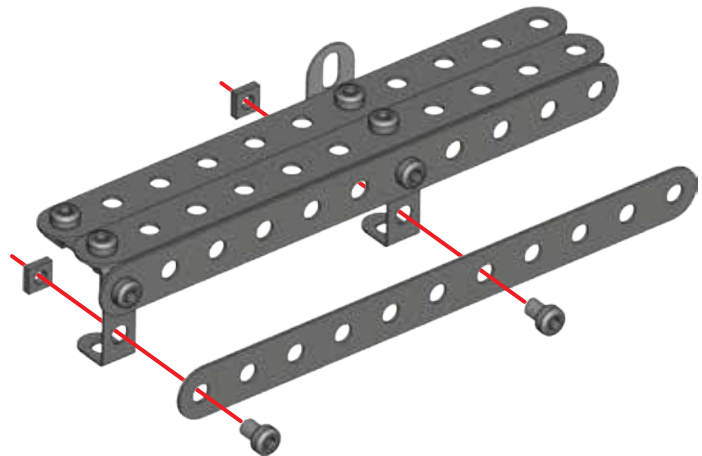
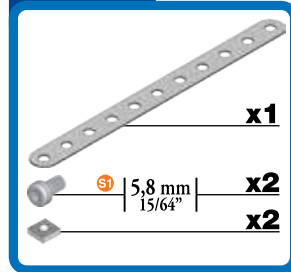



49

45 ~ 48



50



39 + 44 +

 S1	5,8 mm 15/64"	x2
		x2

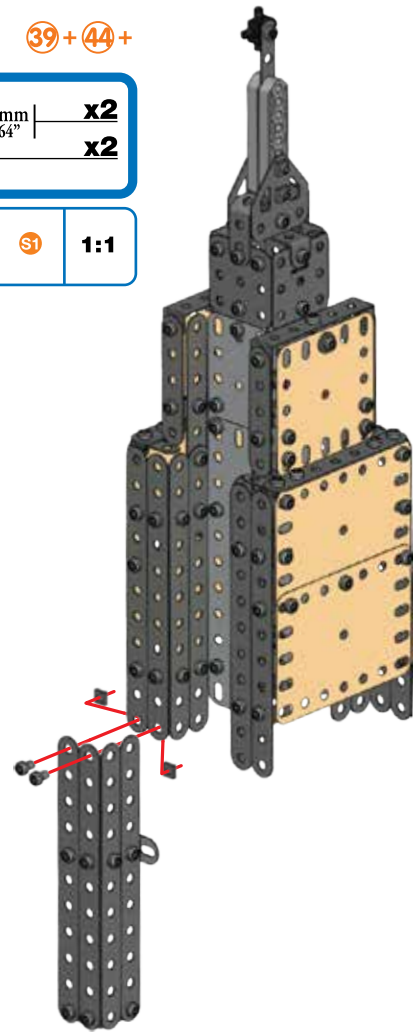
	S1	1:1
--	----	-----



51



 S1	5,8 mm 15/64"	x2
		x2

	S1	1:1
---	----	-----



52

49 + 51 +

 S1	5,8 mm 15/64"	x2
		x2

	S1	1:1
--	----	-----

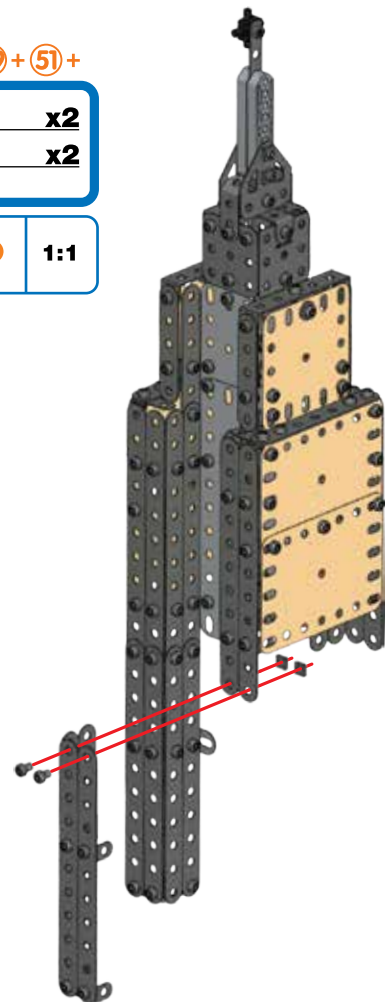

53

5,8 mm | x2
15/64" | x2

1:1

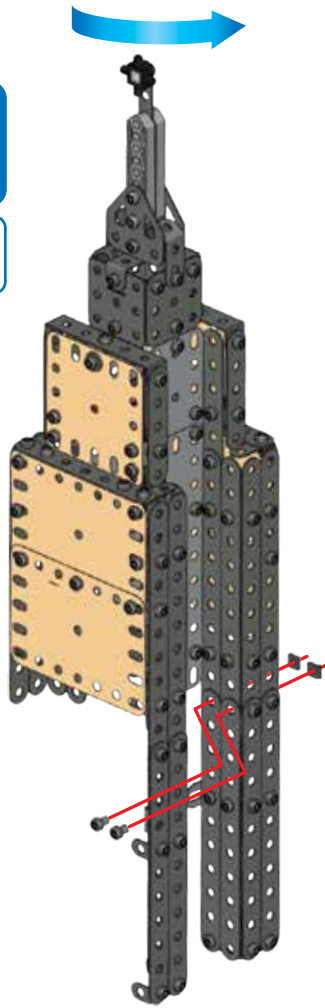

54

44 + 53 +

5,8 mm | x2
15/64" | x2

1:1

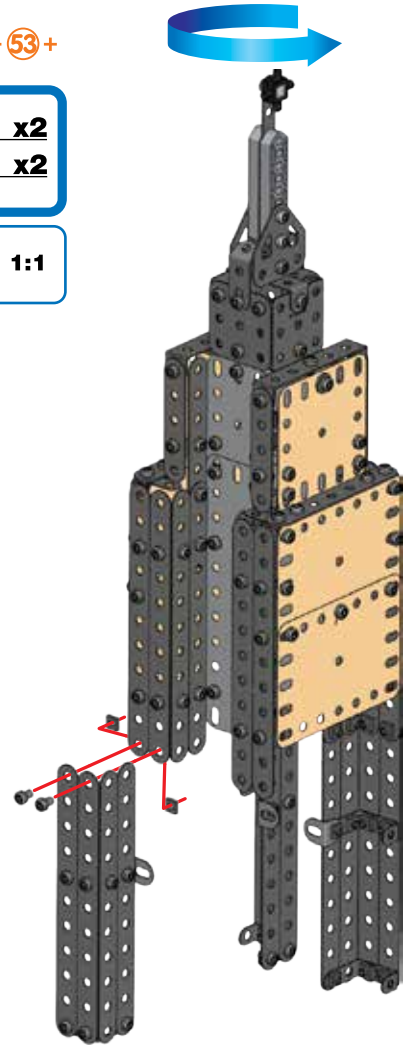

55

5,8 mm | x2
15/64" | x2

1:1

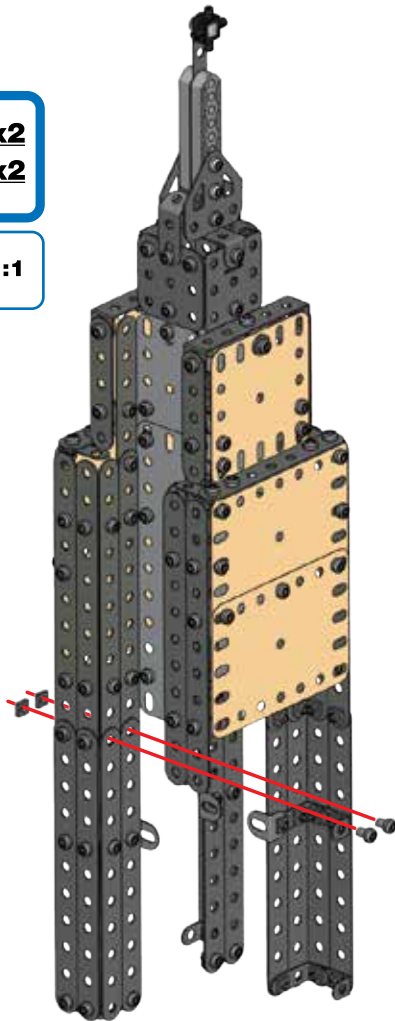

56

49 + 55 +

5,8 mm | x2
15/64" | x2

1:1

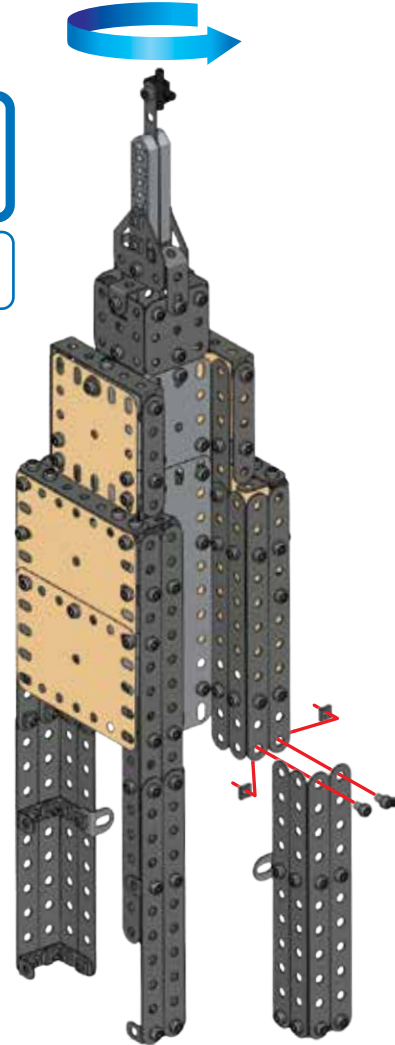

57

 **S1** | 5,8 mm | **x2**
| 15/64" | **x2**

 **S1** | **1:1**

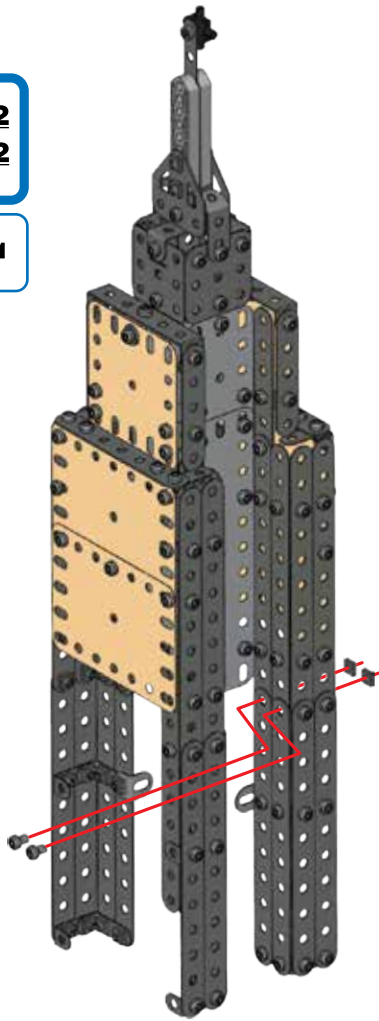

58

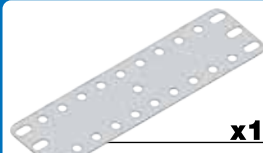

 **x1**

 **S1** | 5,8 mm | **x4**
| 15/64" | **x4**

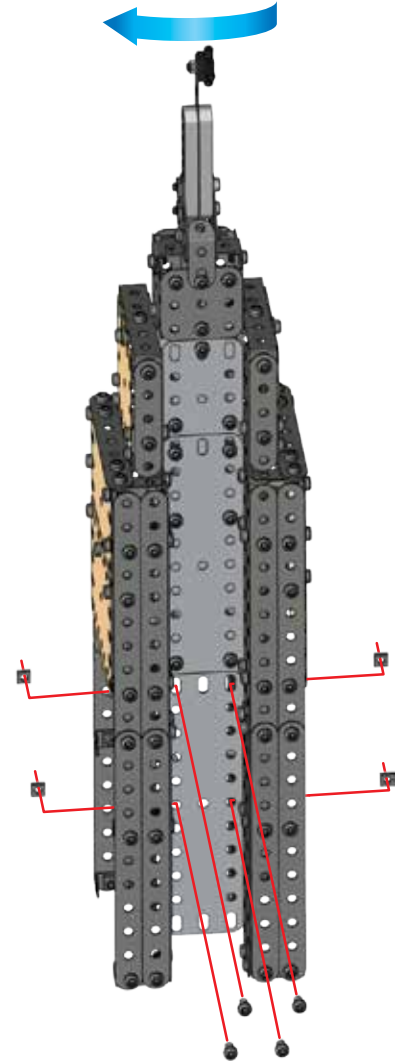
 **S1** | **1:1**



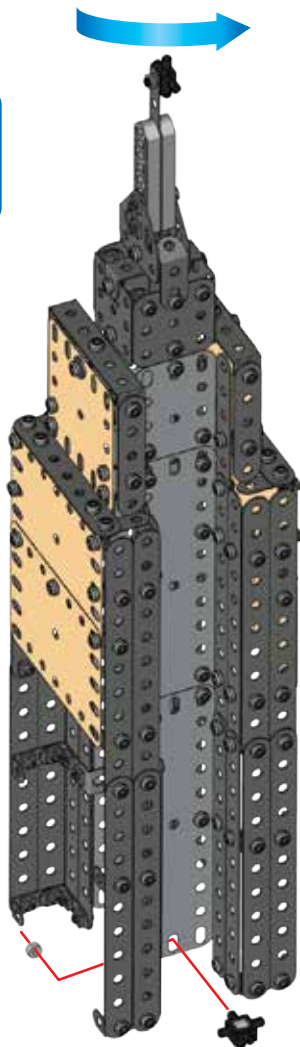

59

 **x1**
 **x1**

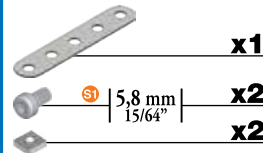

60



 **x1**

 **S1** | 5,8 mm | **x2**
| 15/64" | **x2**

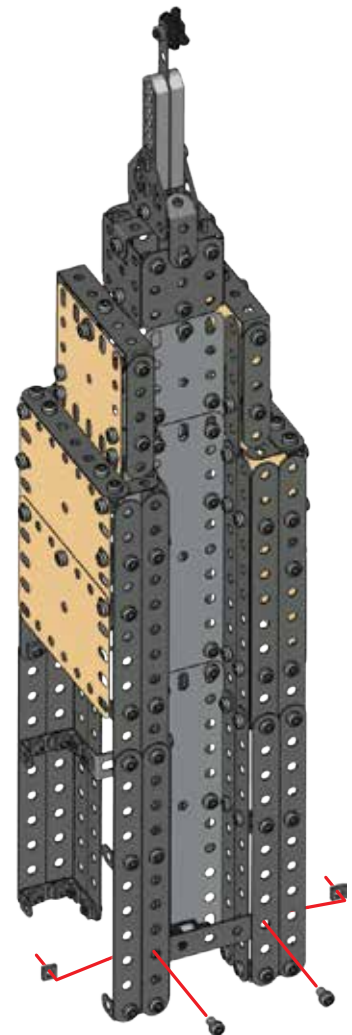
 **S1** | **1:1**





61

	x1
 5,8 mm	x4
 15/64"	x4

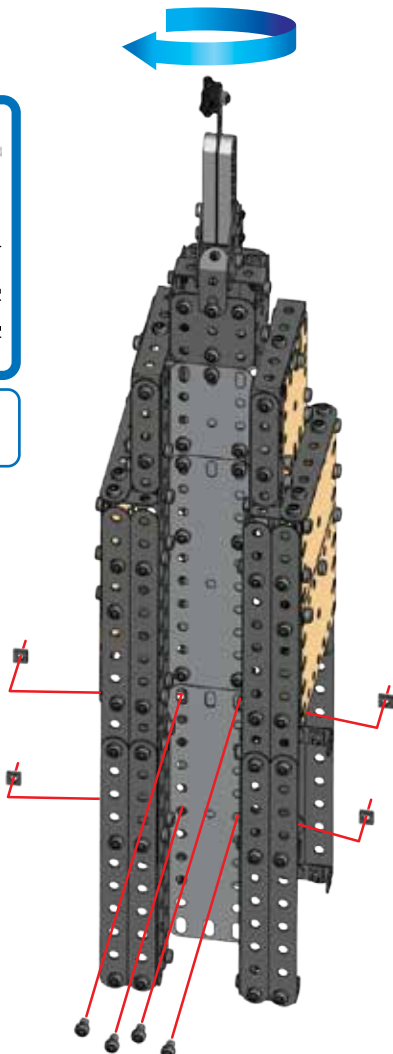
	S1	1:1
---	-----------	------------



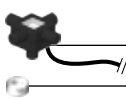

62

	x1
	x1





63

	x1
 5,8 mm	x2
 15/64"	x2

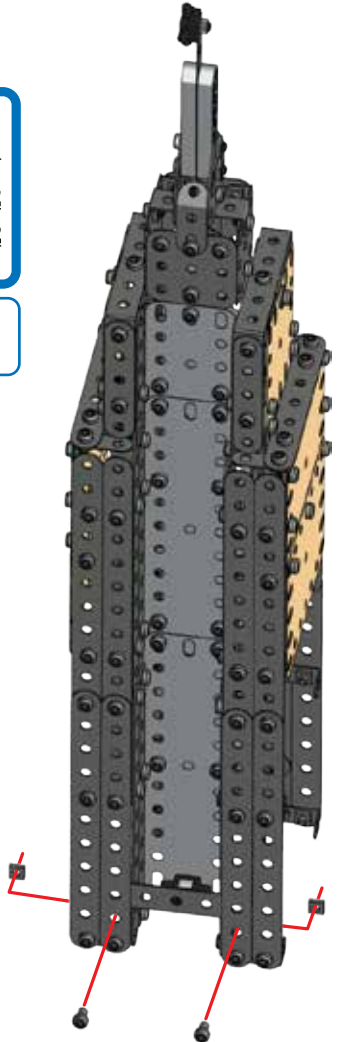
	S1	1:1
---	-----------	------------

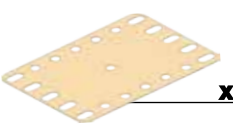

64

	x1
 5,8 mm	x3
 15/64"	x3

	S1	1:1
---	-----------	------------

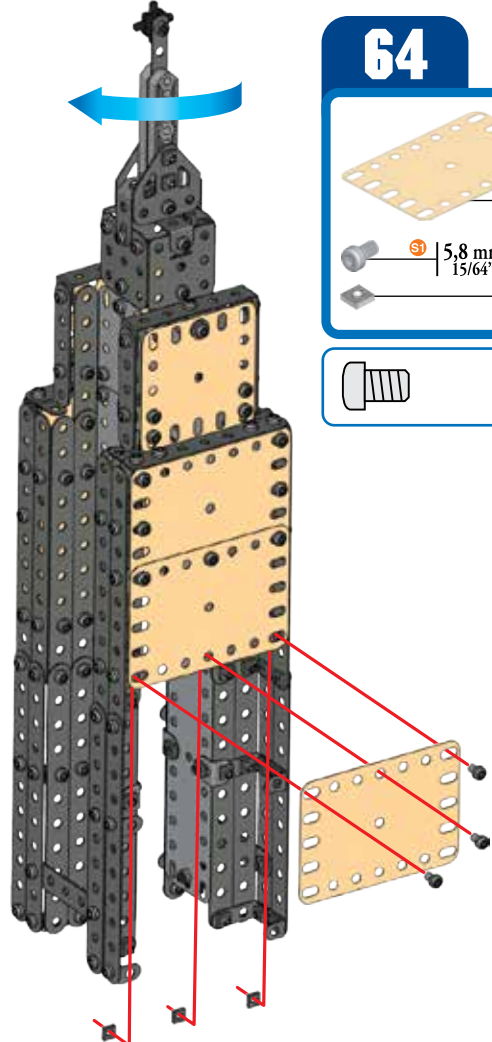

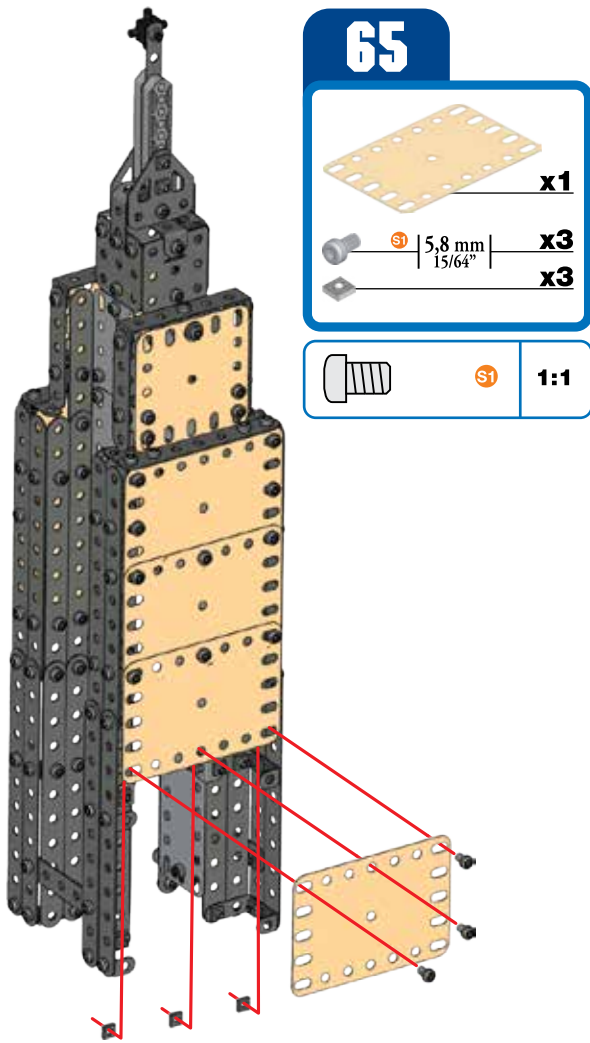

65

	x1
	x3
	x3
	1:1

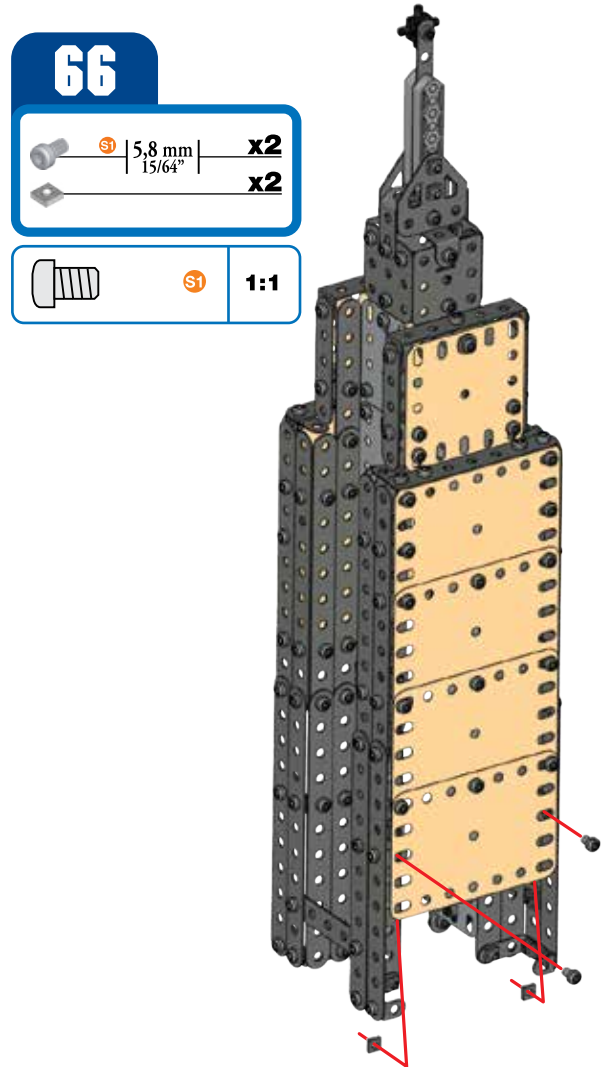

66

	x2
	x2
	1:1

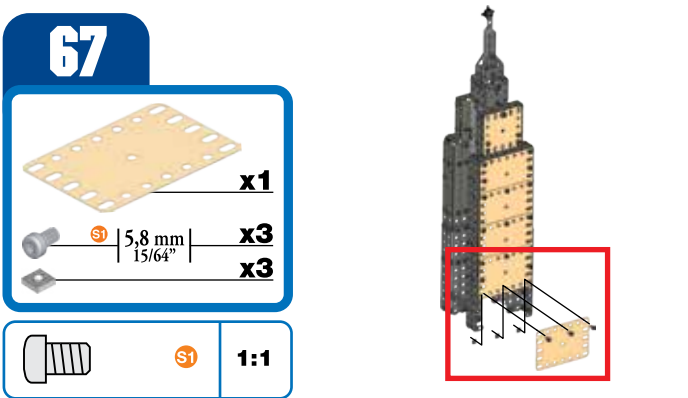

67

	x1
	x3
	x3
	1:1

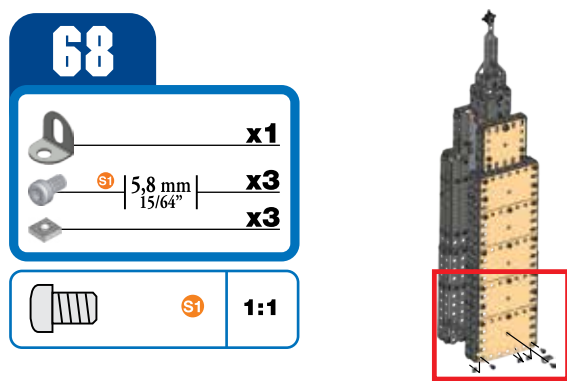
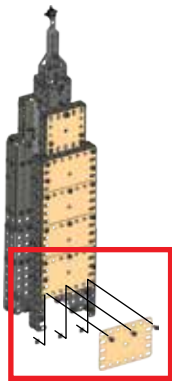

68

	x1
	x3
	x3
	1:1

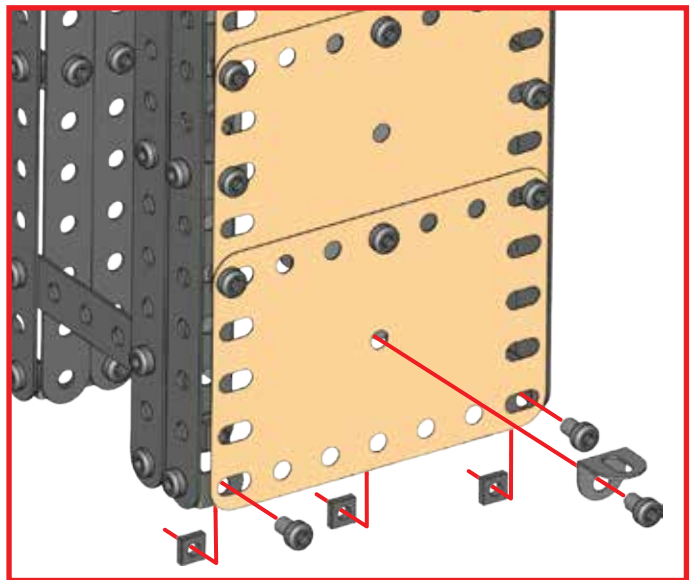
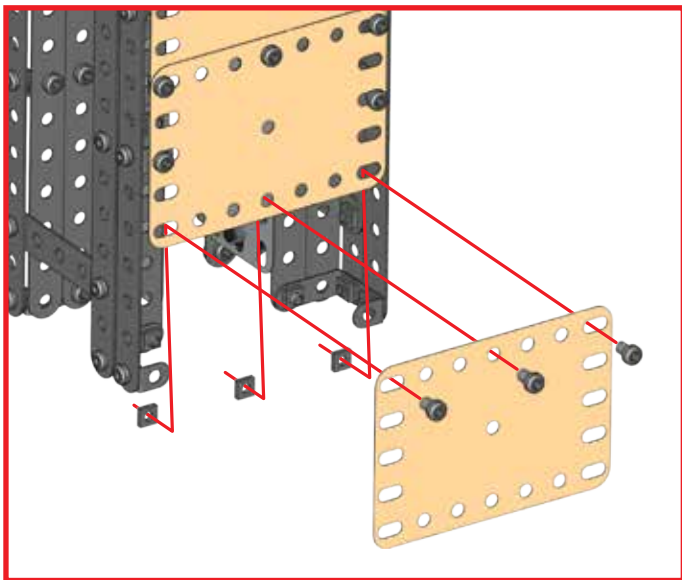

69

x1

x3 | 5,8 mm | **x3**
15/64"

x3

S1 | **1:1**

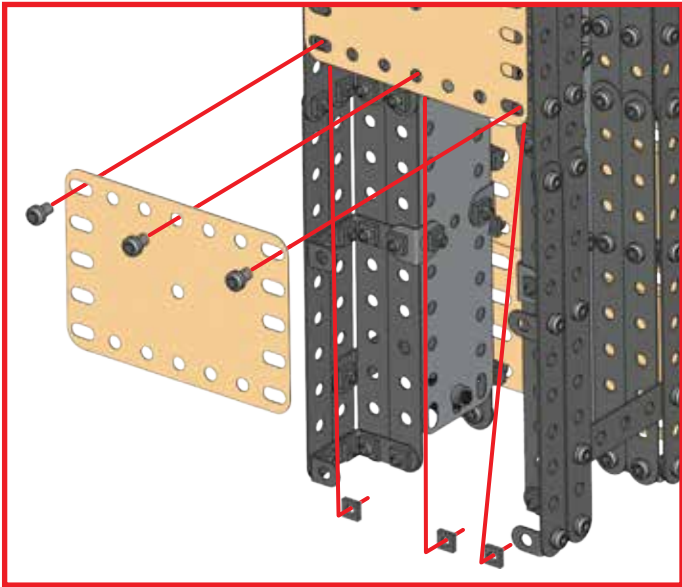
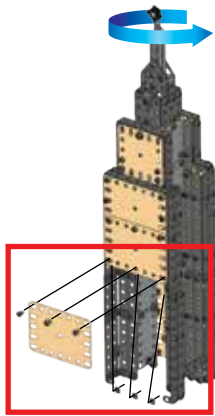

70

x1

x3 | 5,8 mm | **x3**
15/64"

x3

S1 | **1:1**

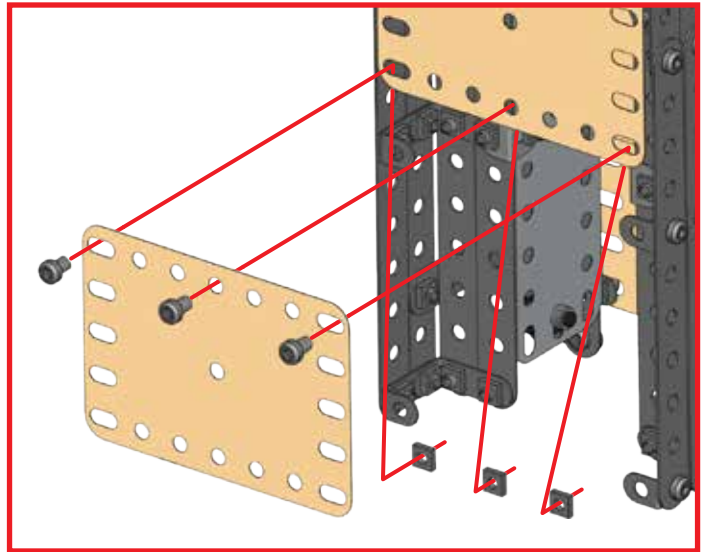
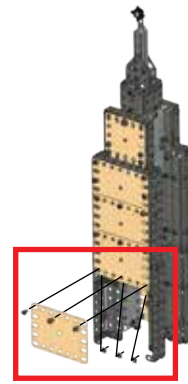

71

x2 | 5,8 mm | **x2**
15/64"

x2

S1 | **1:1**

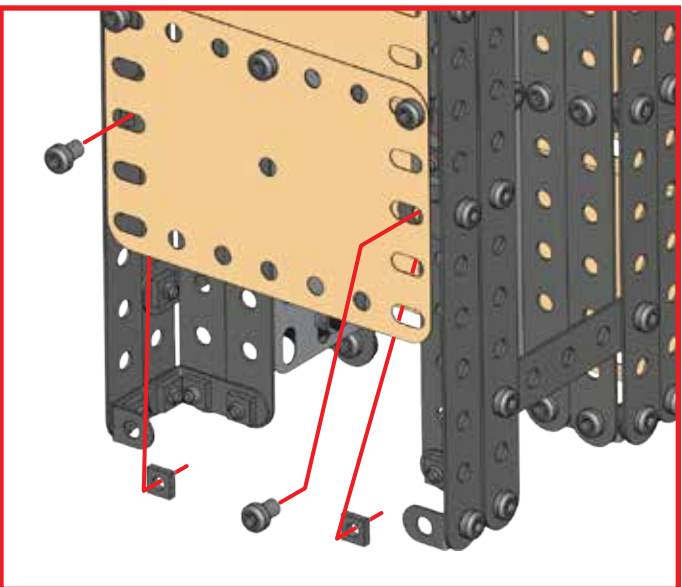
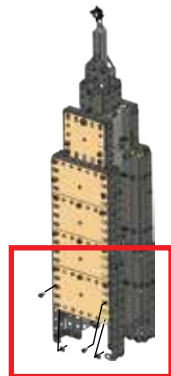

72

x1



x3 | 5,8 mm | **x3**
15/64"

x3

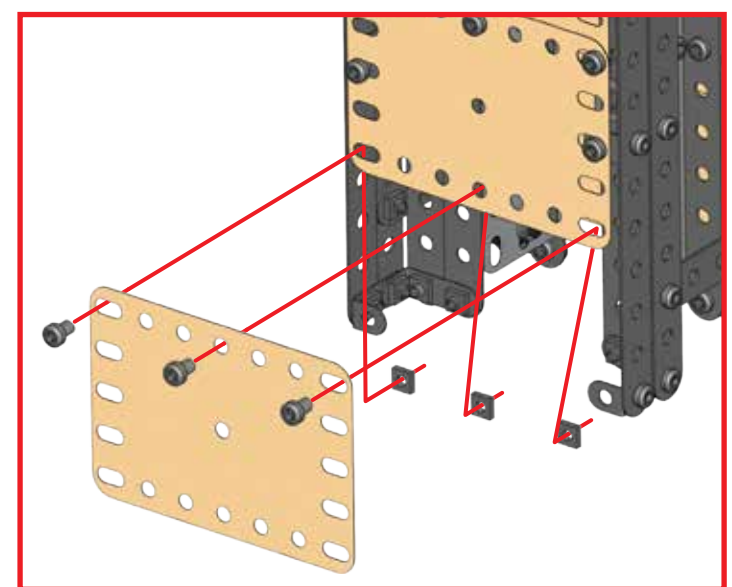
S1 | **1:1**





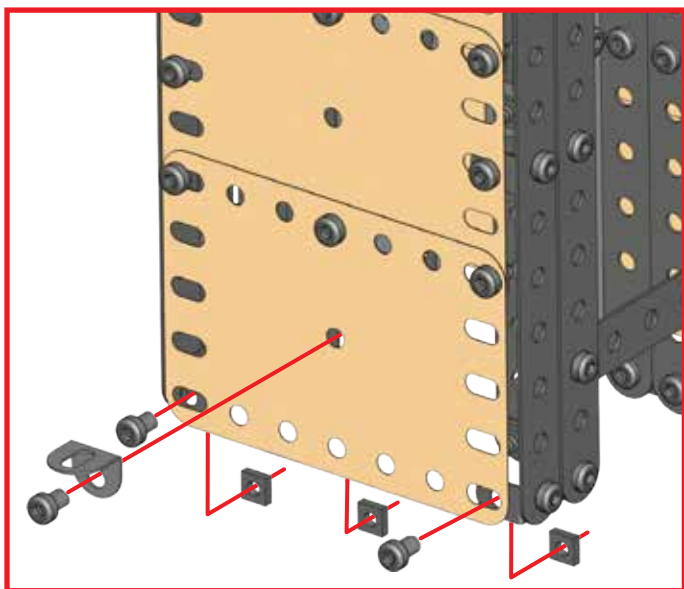
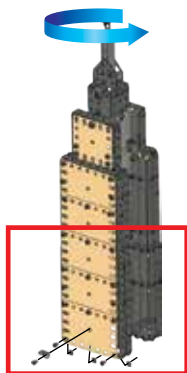

73

-  **x1**
-  **5,8 mm** | **15/64"** **x3**
-  **x3**

-  **1:1**





74

-  **x1**
-  **x2**
-  **5,8 mm** | **15/64"** **x2**
-  **x2**

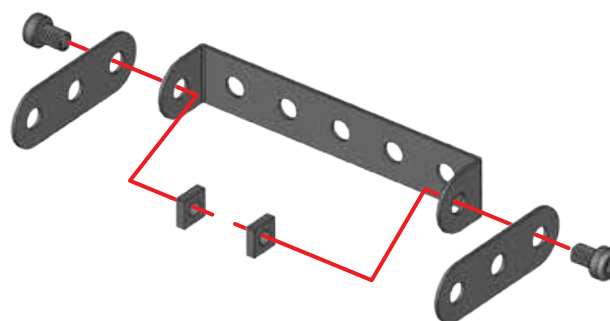
-  **1:1**



75

-  **x2**
-  **5,8 mm** | **15/64"** **x2**
-  **x2**

-  **1:1**

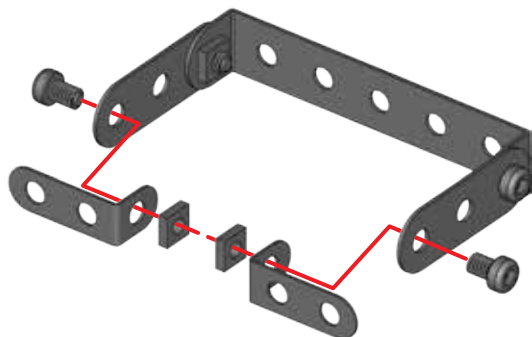



76

74 ~ 75

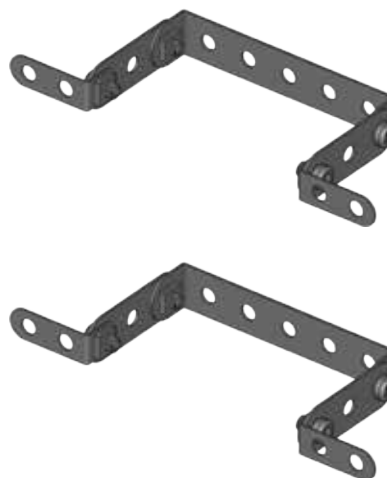
2x





77 73+76+

	x1
 S1 5,8 mm 15/64"	x1
	x1

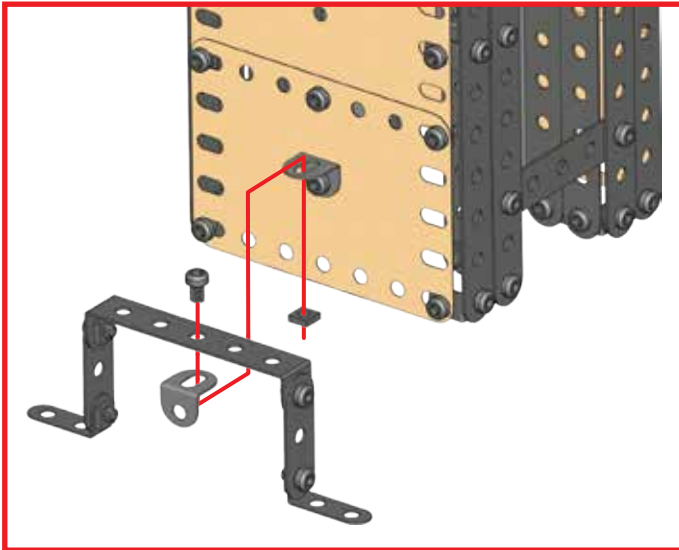
	S1	1:1
---	----	------------





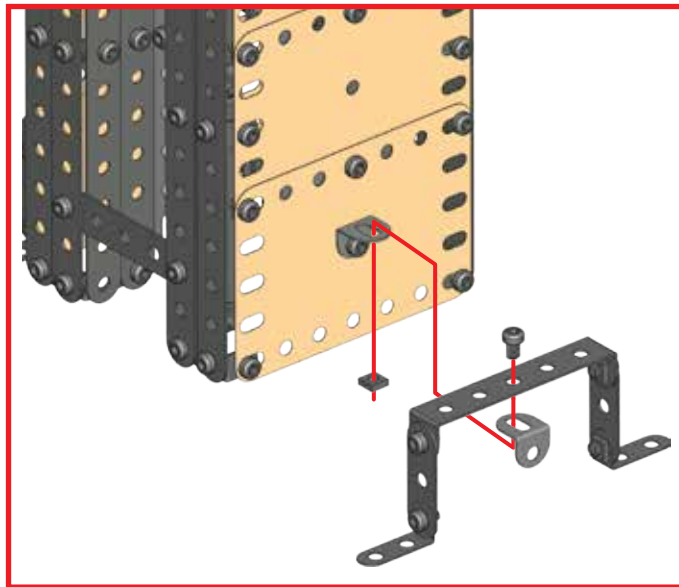
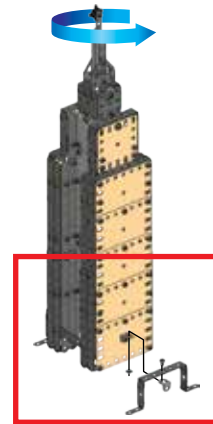

78 76+77+

	x1
 S1 5,8 mm 15/64"	x1
	x1

	S1	1:1
--	----	------------

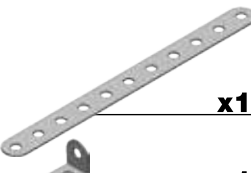



79

	x1
	x1
 S1 5,8 mm 15/64"	x1
	x1

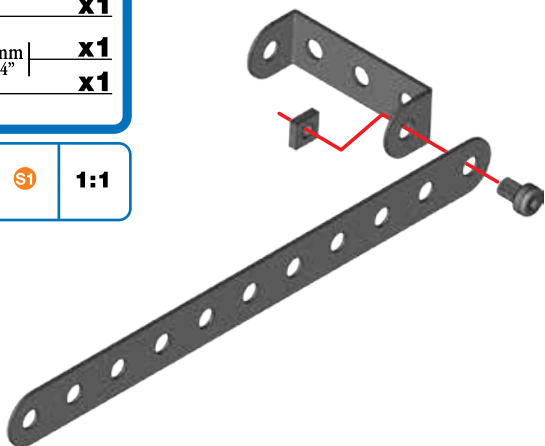
	S1	1:1
---	----	------------



80

	x4
 S1 5,8 mm 15/64"	x2
	x2

	S1	1:1
--	----	------------

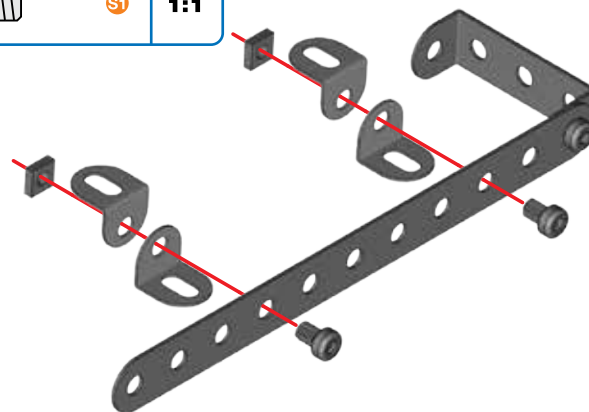

81

	x1
	x2
	x2

	S1	1:1
--	----	-----

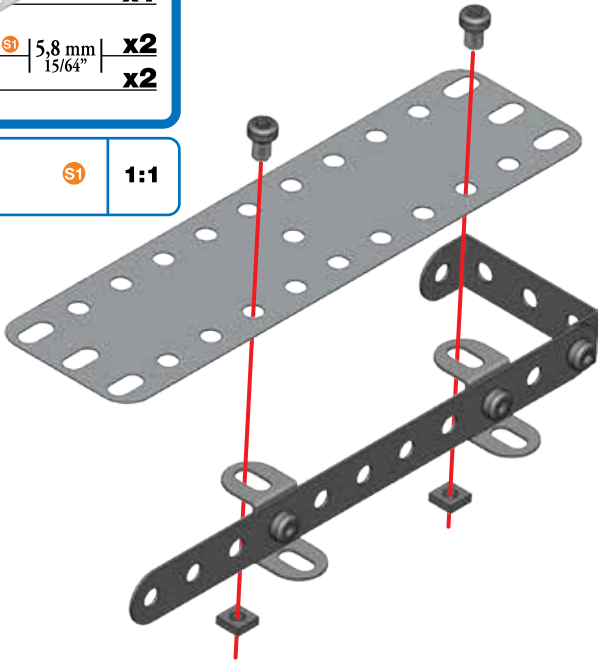

82

	x2
	x2
	x2

	S1	1:1
--	----	-----

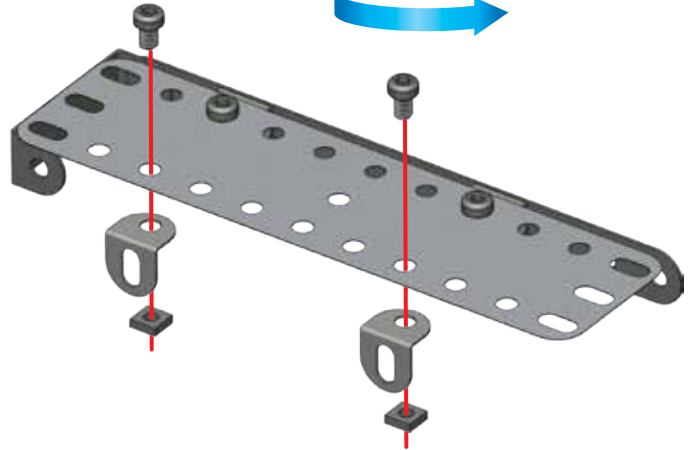

83

79 ~ 82

2x



84

78 + 83 +

	x1
	x1

	S1	1:1
--	----	-----

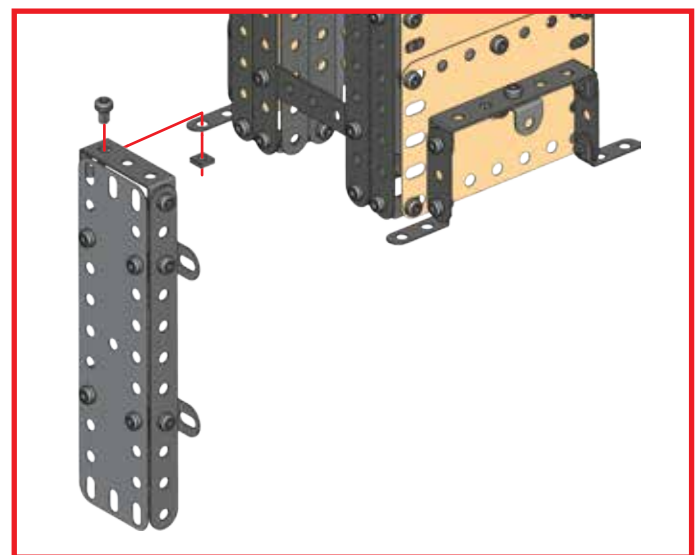

85

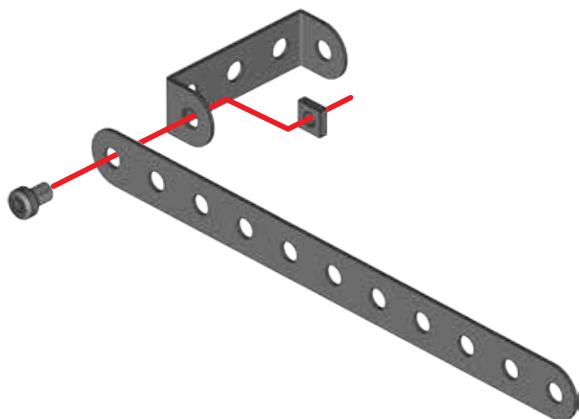
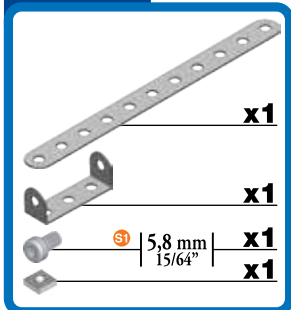

86

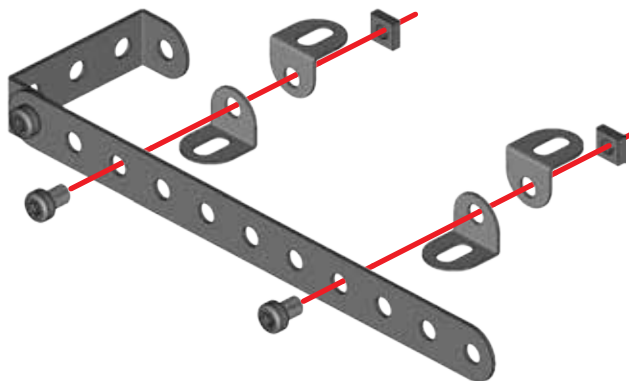
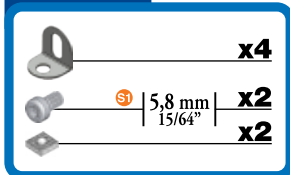

87

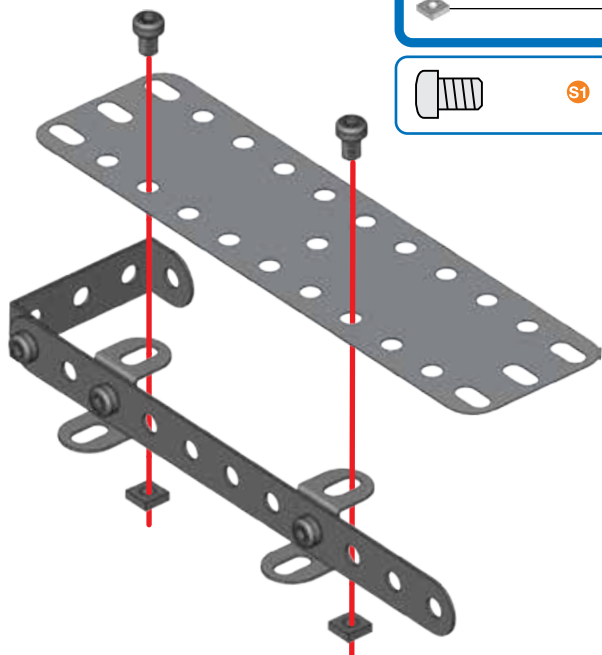
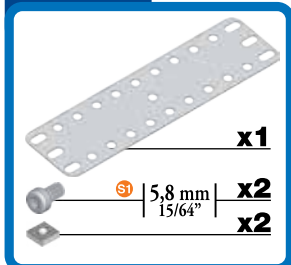

88

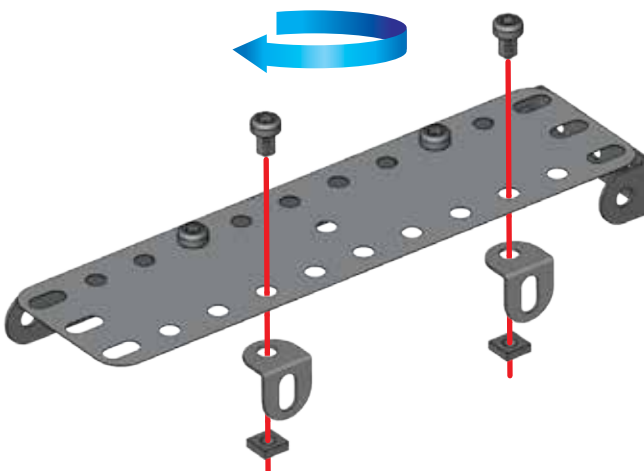
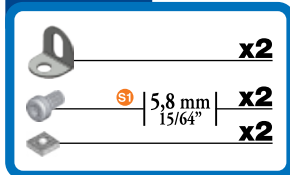

89

85 ~ 88

2x

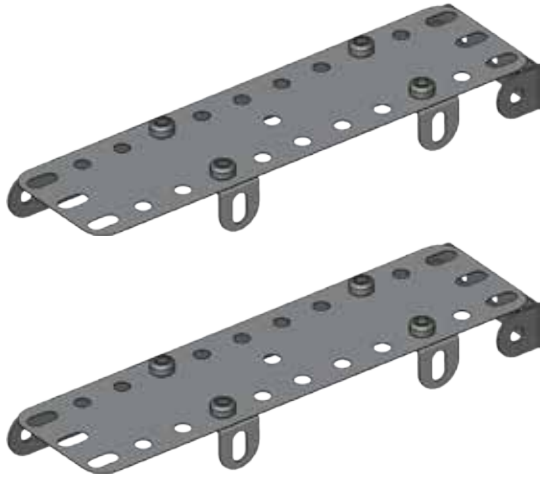

90

84 + 89 +

	5,8 mm 15/64"	x1
		x1

	S1	1:1
--	----	-----

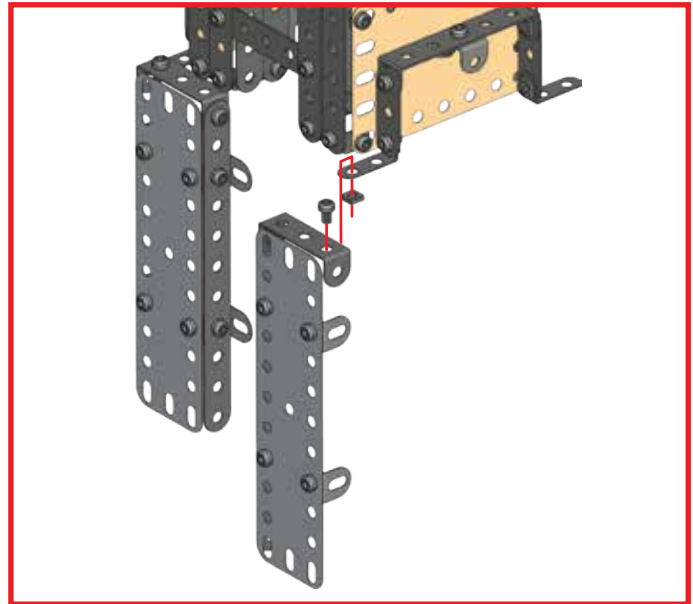
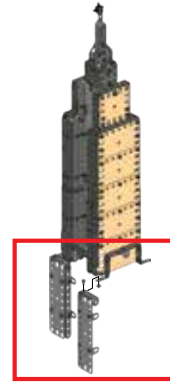

91

	x1	
	x1	
	5,8 mm 15/64"	x2
		x2

	S1	1:1
--	----	-----

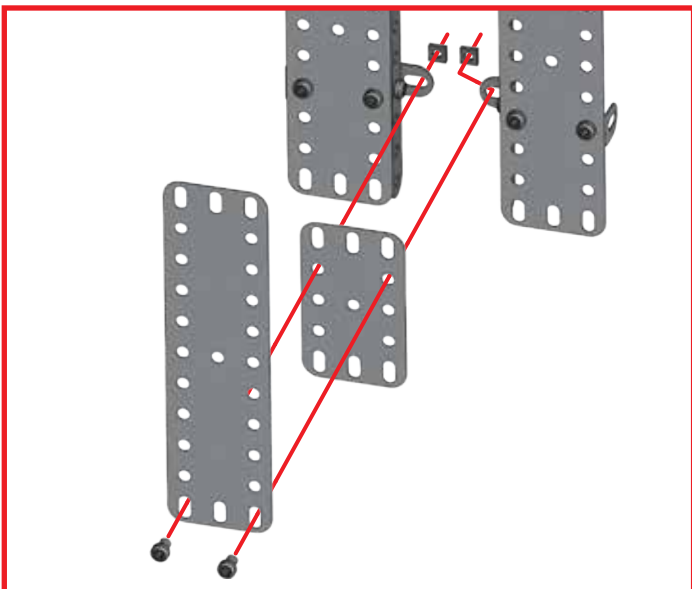

92

	5,8 mm 15/64"	x4
		x4

	S1	1:1
--	----	-----

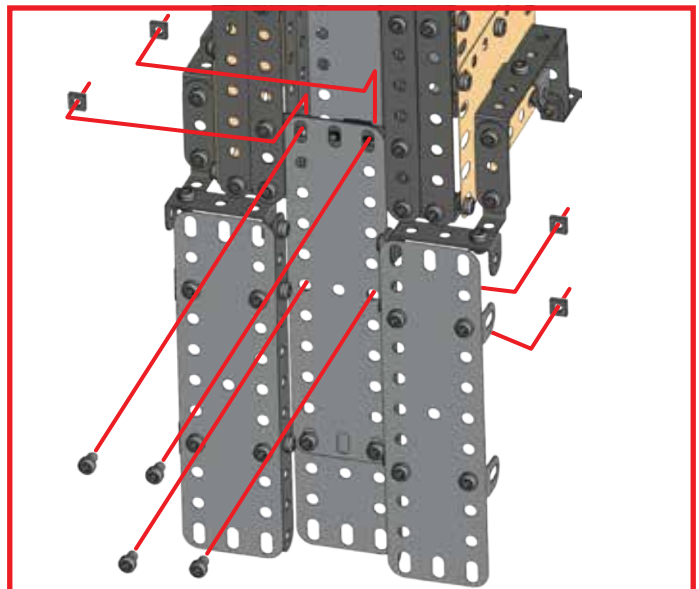
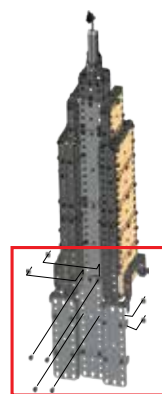

93

83 + 89 + 92 +

5,8 mm | x2
15/64" | x2

1:1

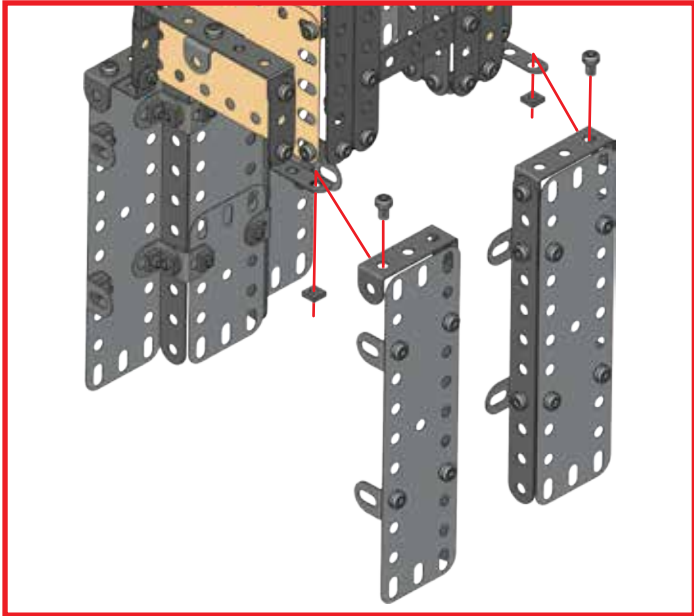

94

x1
x1
5,8 mm | x2
15/64" | x2

1:1

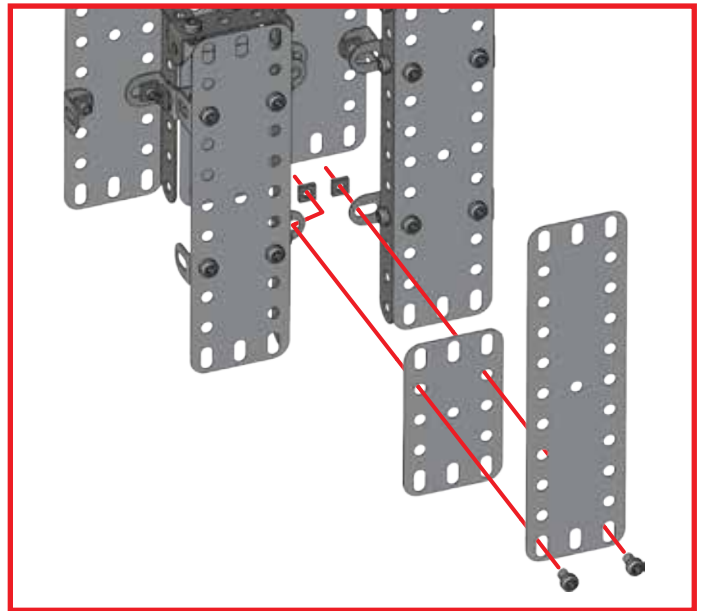

95

x1
5,8 mm | x1
15/64" | x1

1:1

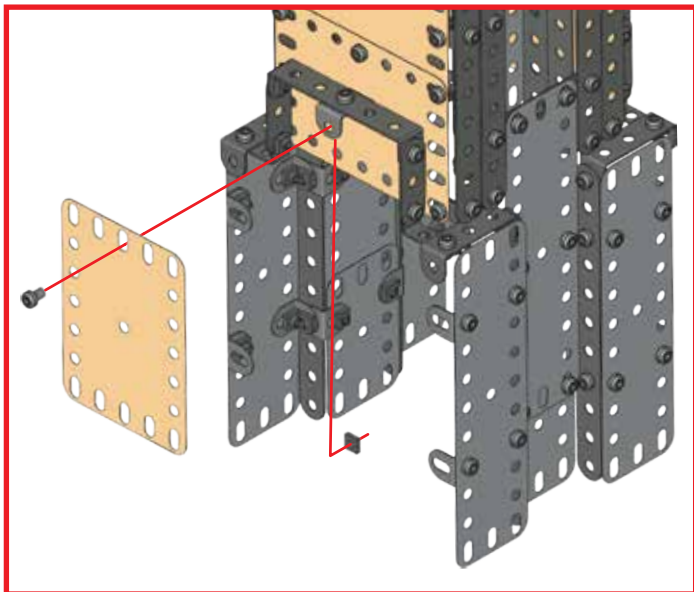
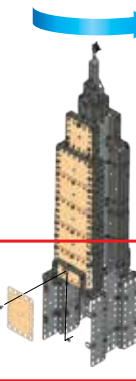

96

x1
5,8 mm | x4
15/64" | x4

1:1

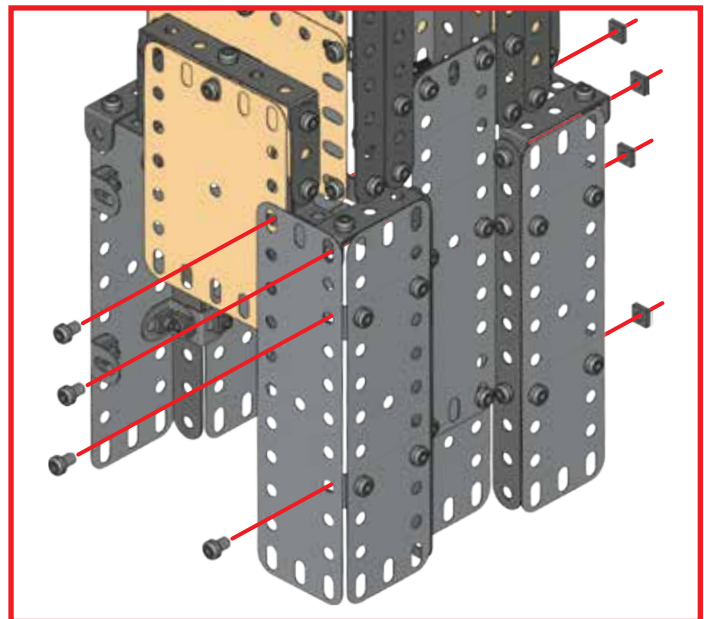
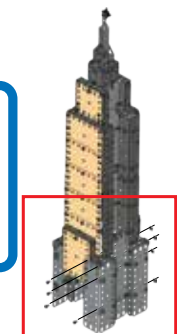

97

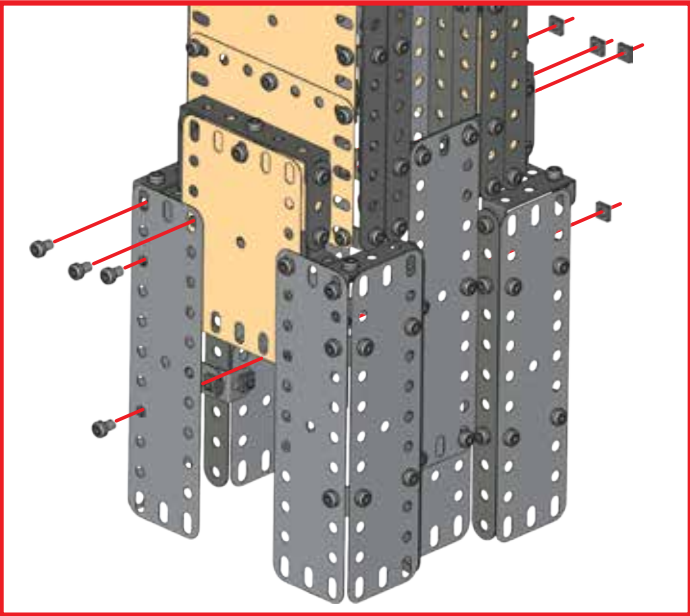
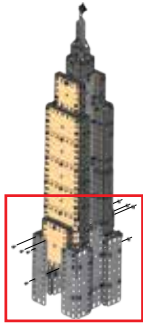
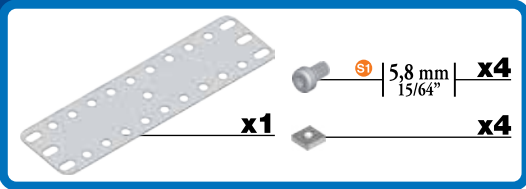

98

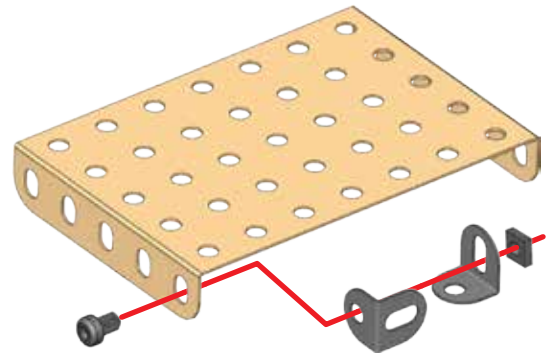
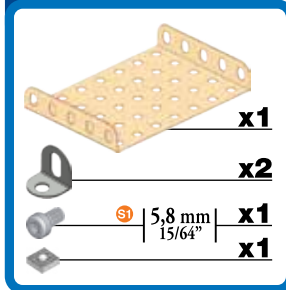

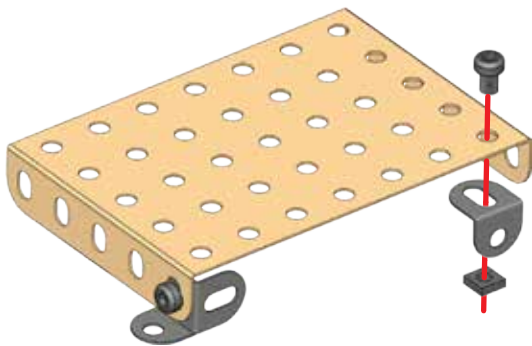
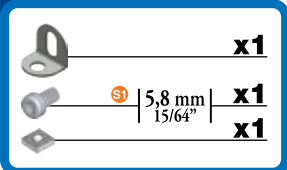

99

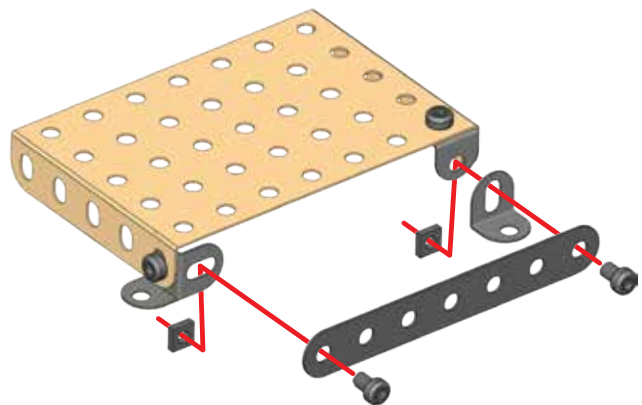
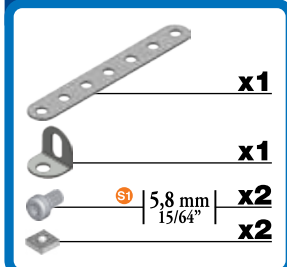

100





101

-  **x2**
-  | 5,8 mm | **x1**
-  | 15/64" | **x1**

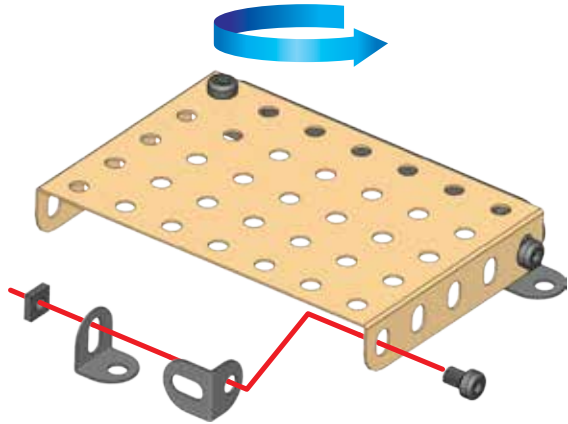
-  **S1** | **1:1**







102

-  **x1**
-  | 5,8 mm | **x1**
-  | 15/64" | **x1**

-  **S1** | **1:1**

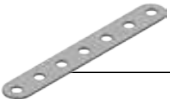

103

-  **x1**
-  **x1**
-  | 5,8 mm | **x2**
-  | 15/64" | **x2**

-  **S1** | **1:1**

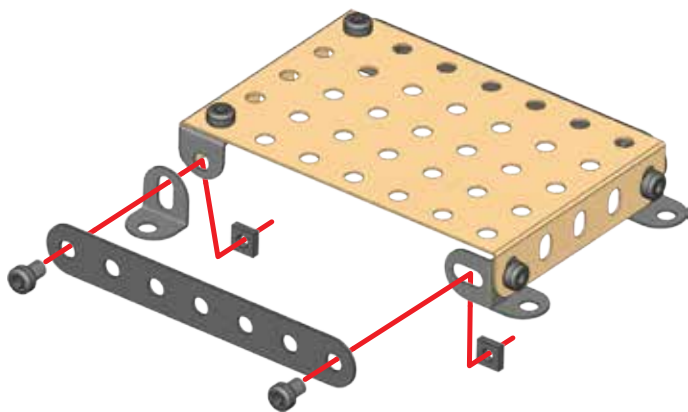



104

-  **98 ~ 103**

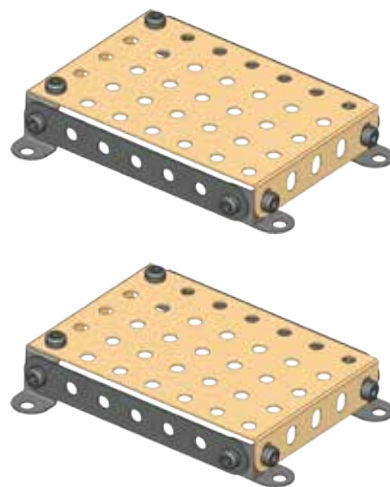
2x





105 97 + 104 +

	S1 5,8 mm	x4
		x4

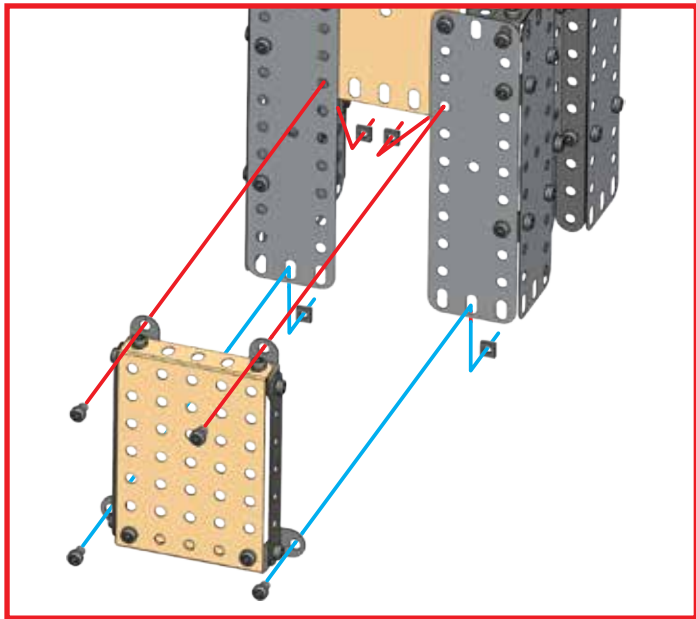
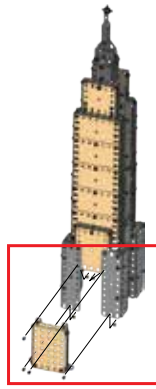
	S1	1:1
---	----	------------



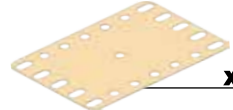

106

		x1
	S1 5,8 mm	x1
		x1

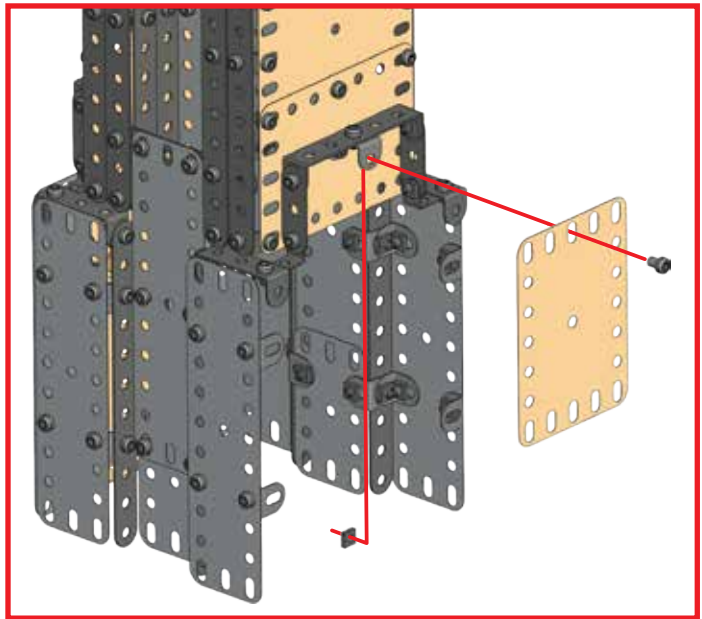
	S1	1:1
--	----	------------



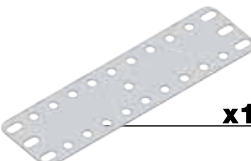

107

		S1 5,8 mm	x4
			x4

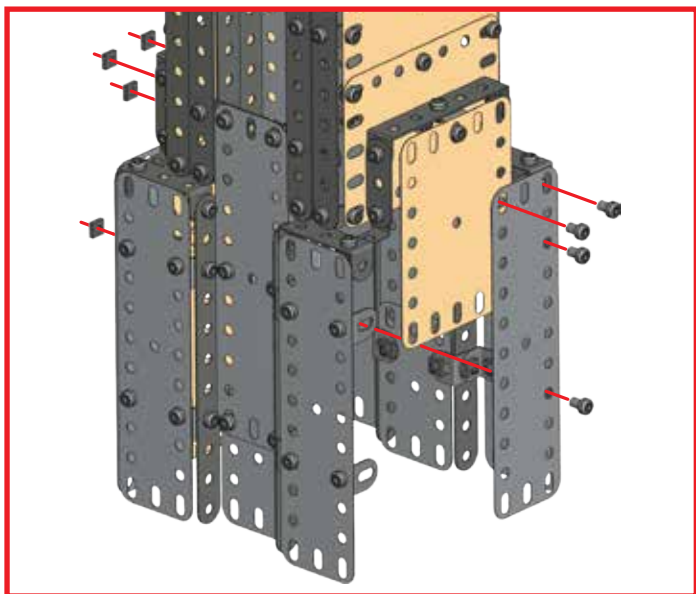
	S1	1:1
---	----	------------



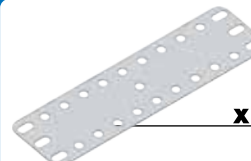

108

		S1 5,8 mm	x4
			x4

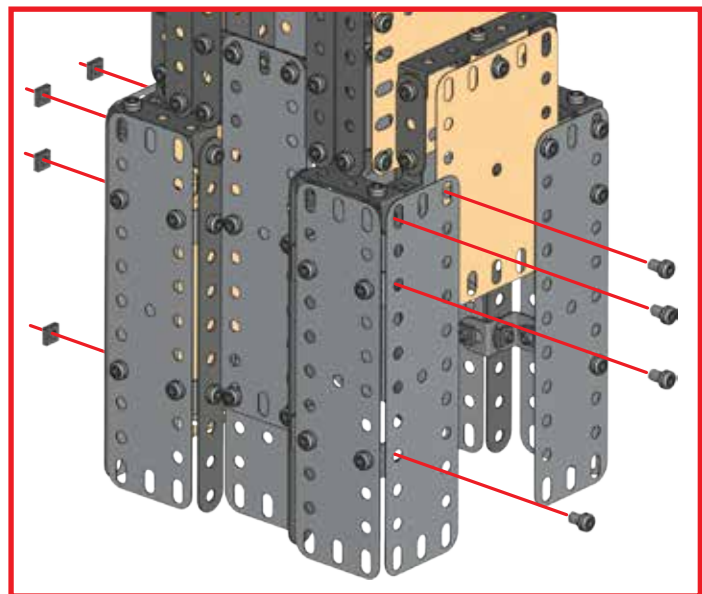
	S1	1:1
--	----	------------





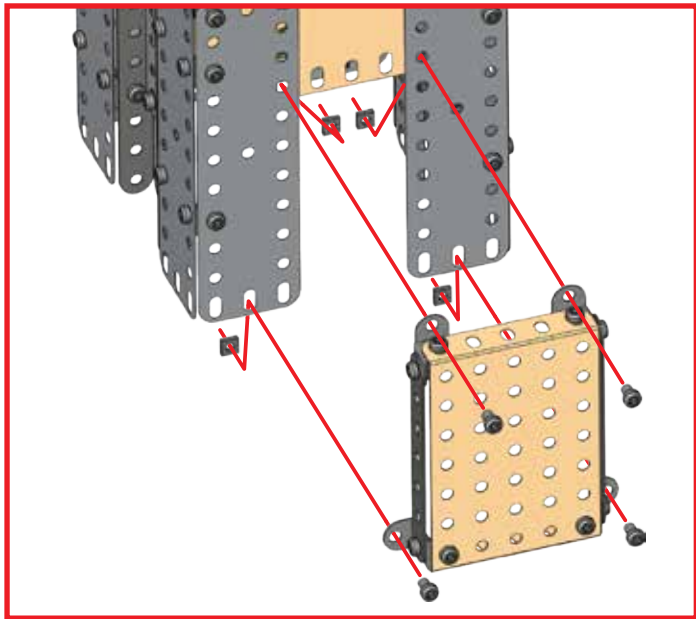
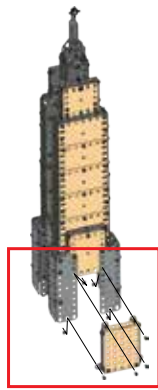

109 (104 + 108) +

	5,8 mm 15/64"	x4
		x4

	S1	1:1
---	-----------	------------

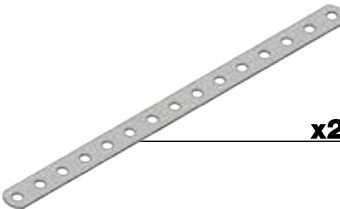



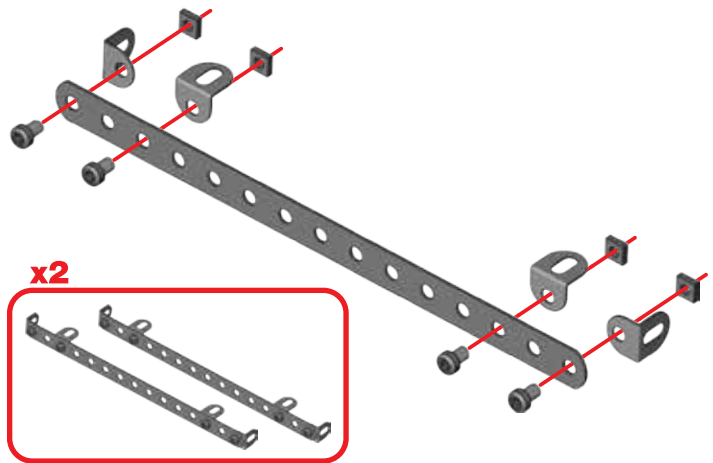

110

		x2
		x8
	5,8 mm 15/64"	x8
		x8

	S1	1:1
--	-----------	------------

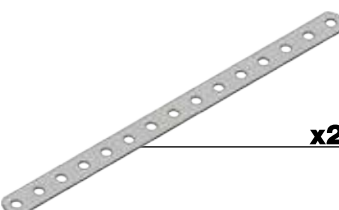



111

		x2
		x4
	5,8 mm 15/64"	x4
		x4

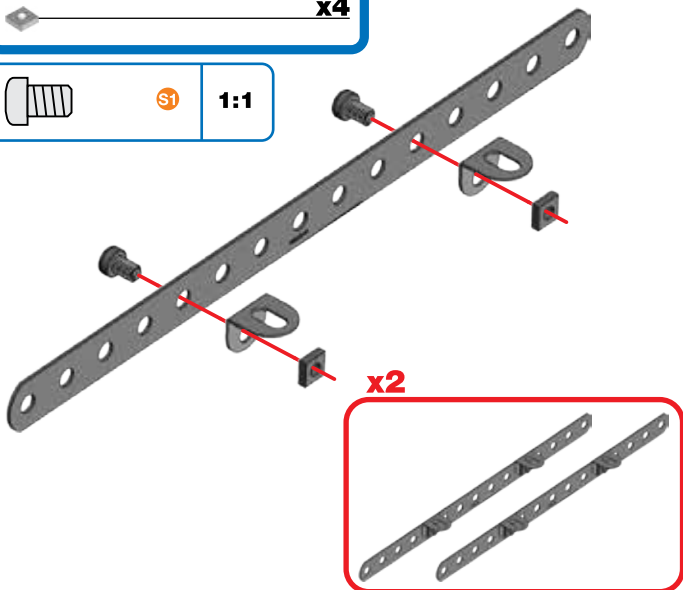
	S1	1:1
---	-----------	------------





112 (110 + 111) +

	5,8 mm 15/64"	x1
		x1

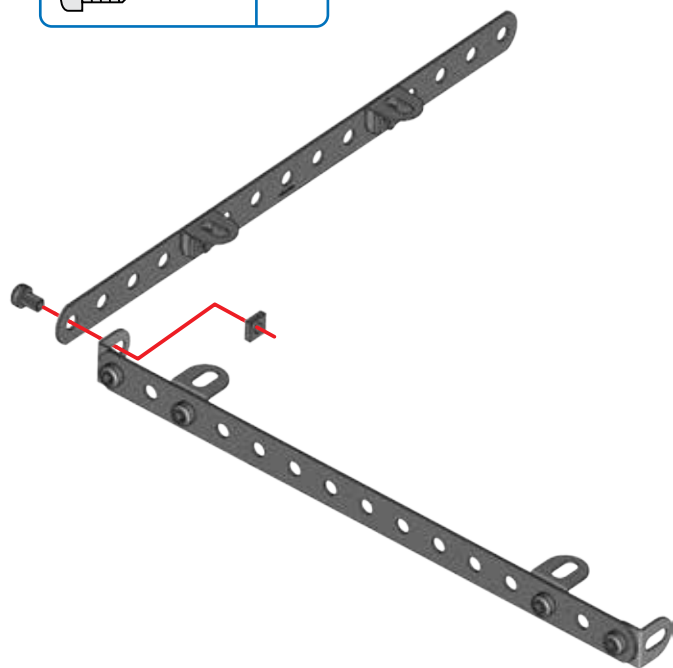
	S1	1:1
--	-----------	------------





113 (110) + (112) +

	S1 5,8 mm 15/64"	x1
		x1

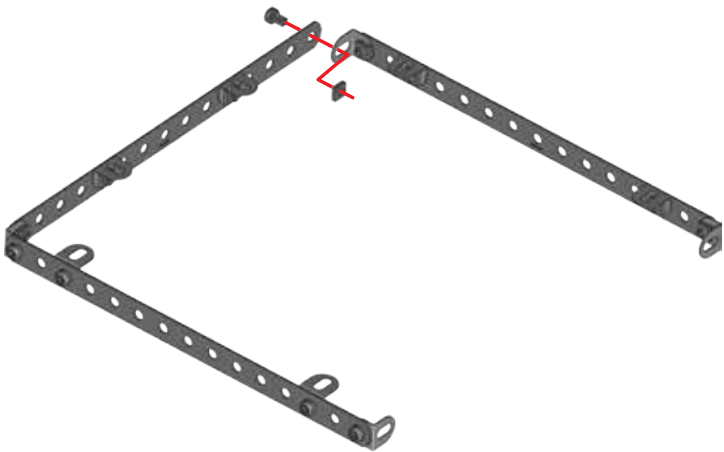
	S1	1:1
---	----	------------





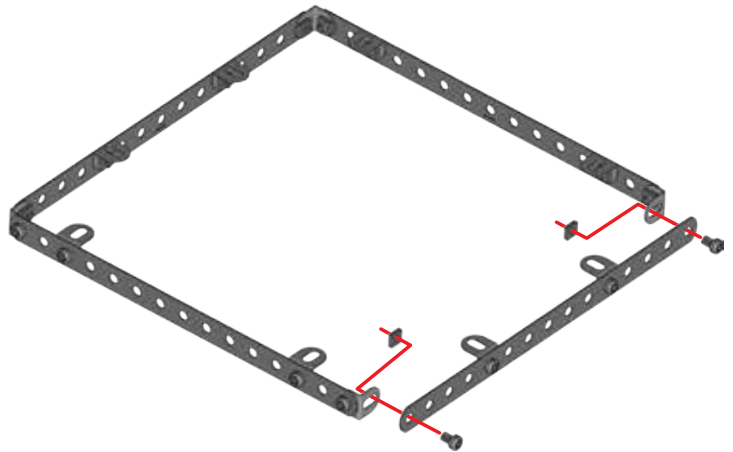

114 (111) + (113) +

	S1 5,8 mm 15/64"	x2
		x2

	S1	1:1
--	----	------------





115

		x1
		x1
		x2
	S1 5,8 mm 15/64"	x2
		x2

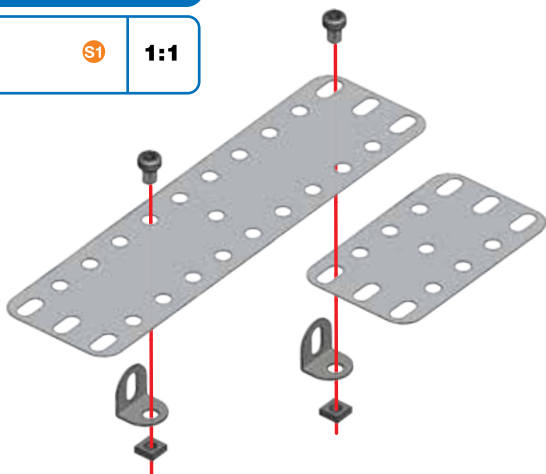
	S1	1:1
---	----	------------



116

		x1
	S1 5,8 mm 15/64"	x2
		x2

	S1	1:1
--	----	------------

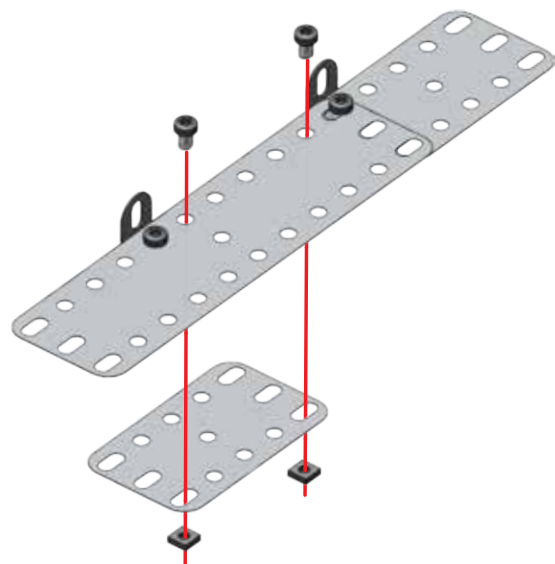

117

115 ~ 116

2x

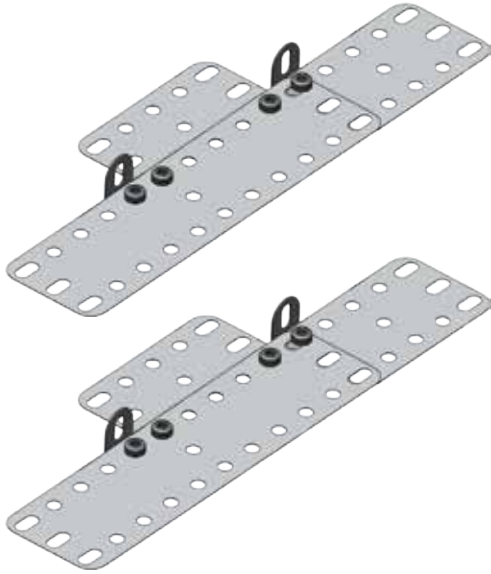

118

117+

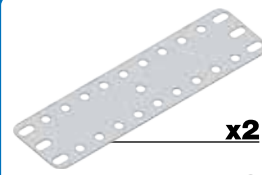

x2

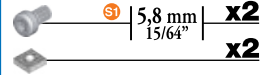

S1 | 5,8 mm | x2

15/64" | x2



S1

1:1

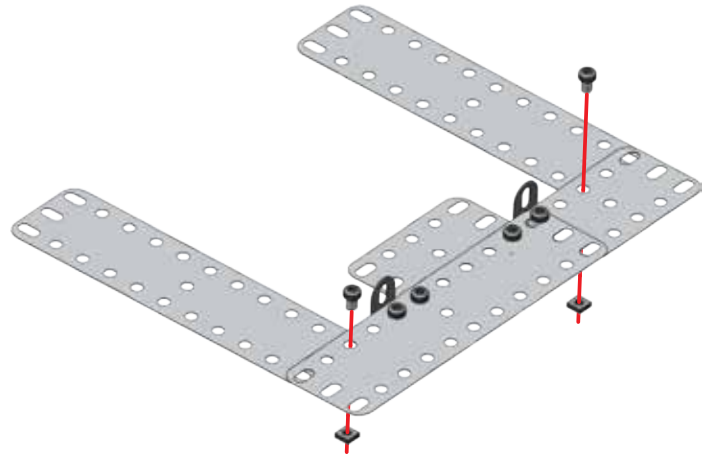

119

117 + 118 +

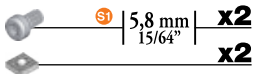

S1 | 5,8 mm | x2

15/64" | x2



S1

1:1

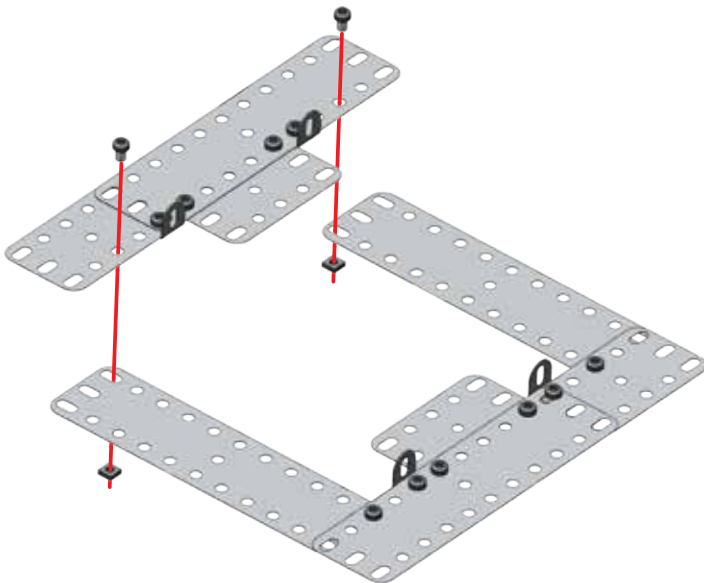

120

114 + 119 +

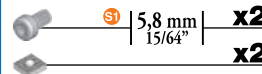

S1 | 5,8 mm | x2

15/64" | x2



S1

1:1

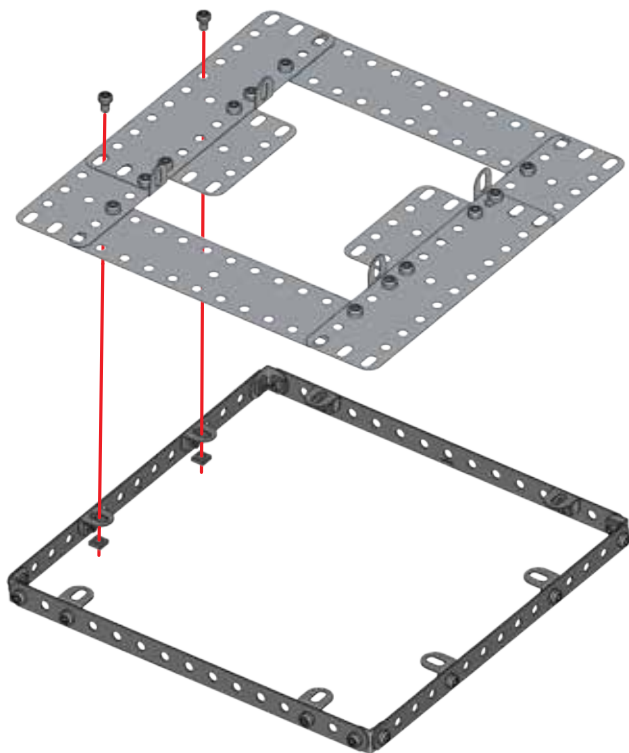

121

 **S1** | 5,8 mm | **x2**
| 15/64" | **x2**

 **S1** | **1:1**

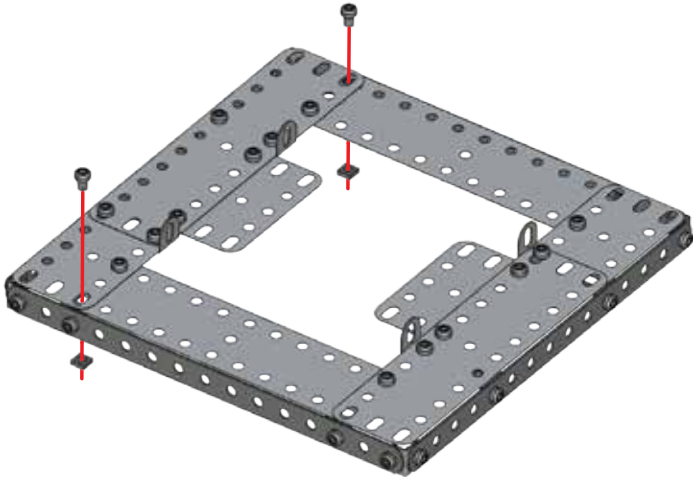

122

 **S1** | 5,8 mm | **x2**
| 15/64" | **x2**

 **S1** | **1:1**

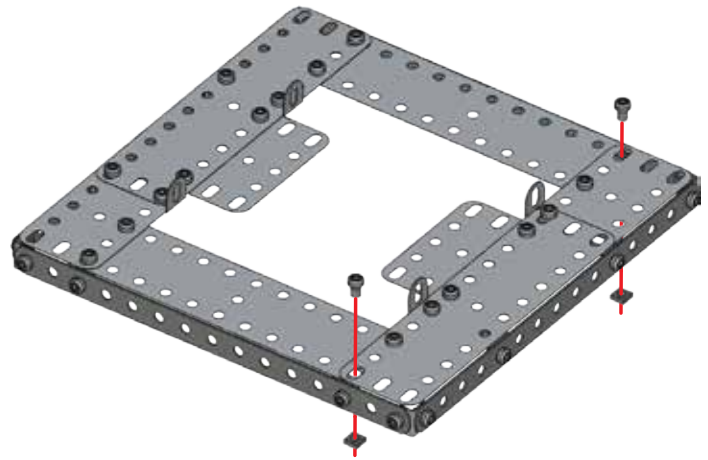

123

 **S1** | 5,8 mm | **x2**
| 15/64" | **x2**

 **S1** | **1:1**

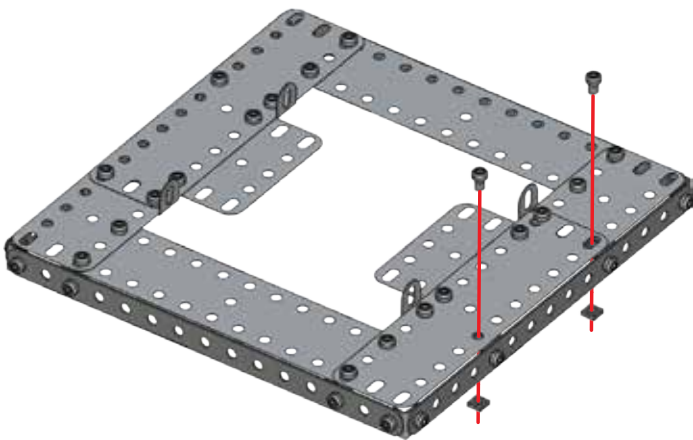

124

109 + 123 +

 **S1** | 5,8 mm | **x2**
| 15/64" | **x2**

 **S1** | **1:1**

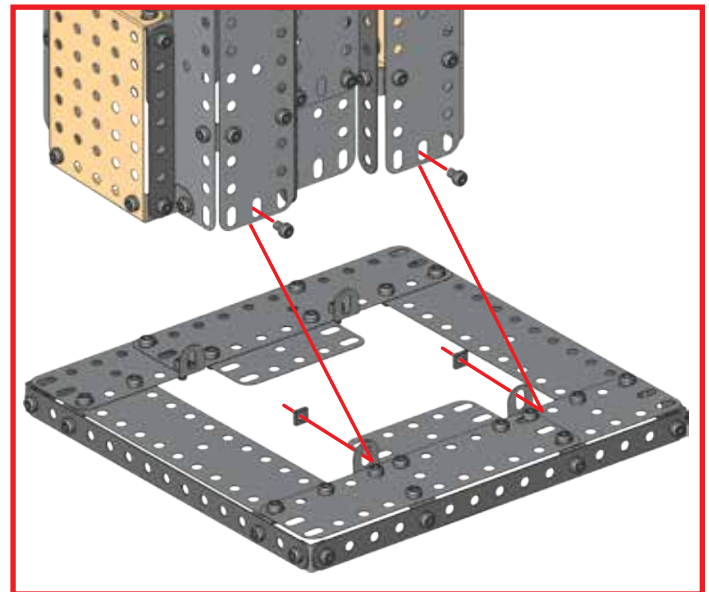
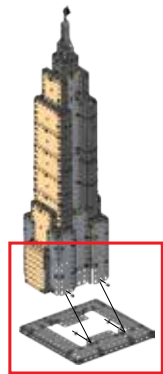



125

 **S1** | 5,8 mm | **x2**
| 15/64" | **x2**

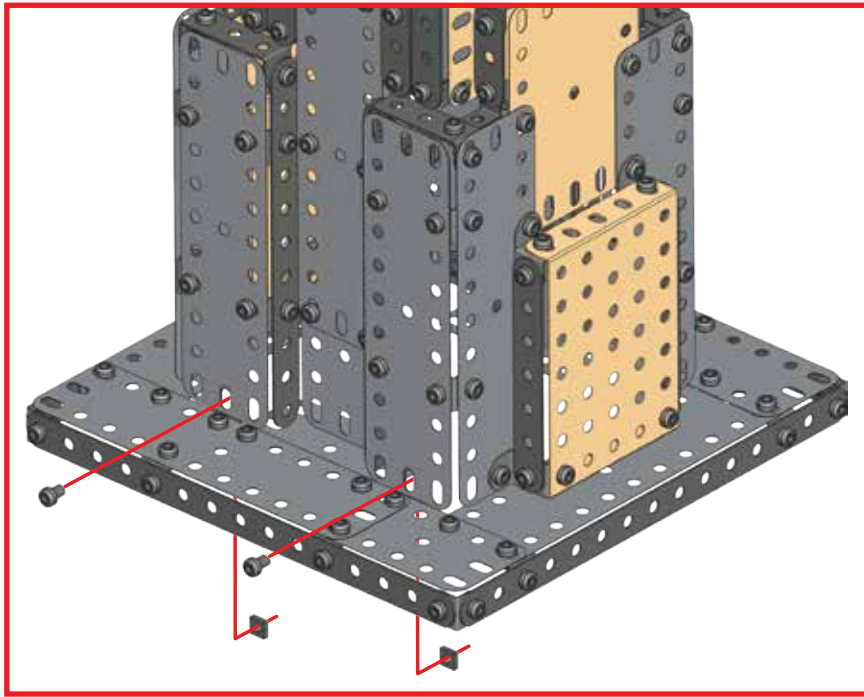
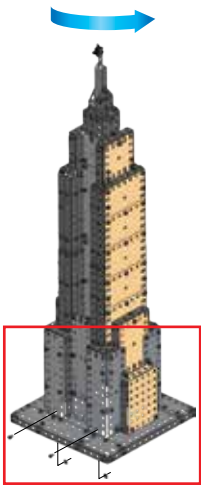
 **S1** | **1:1**



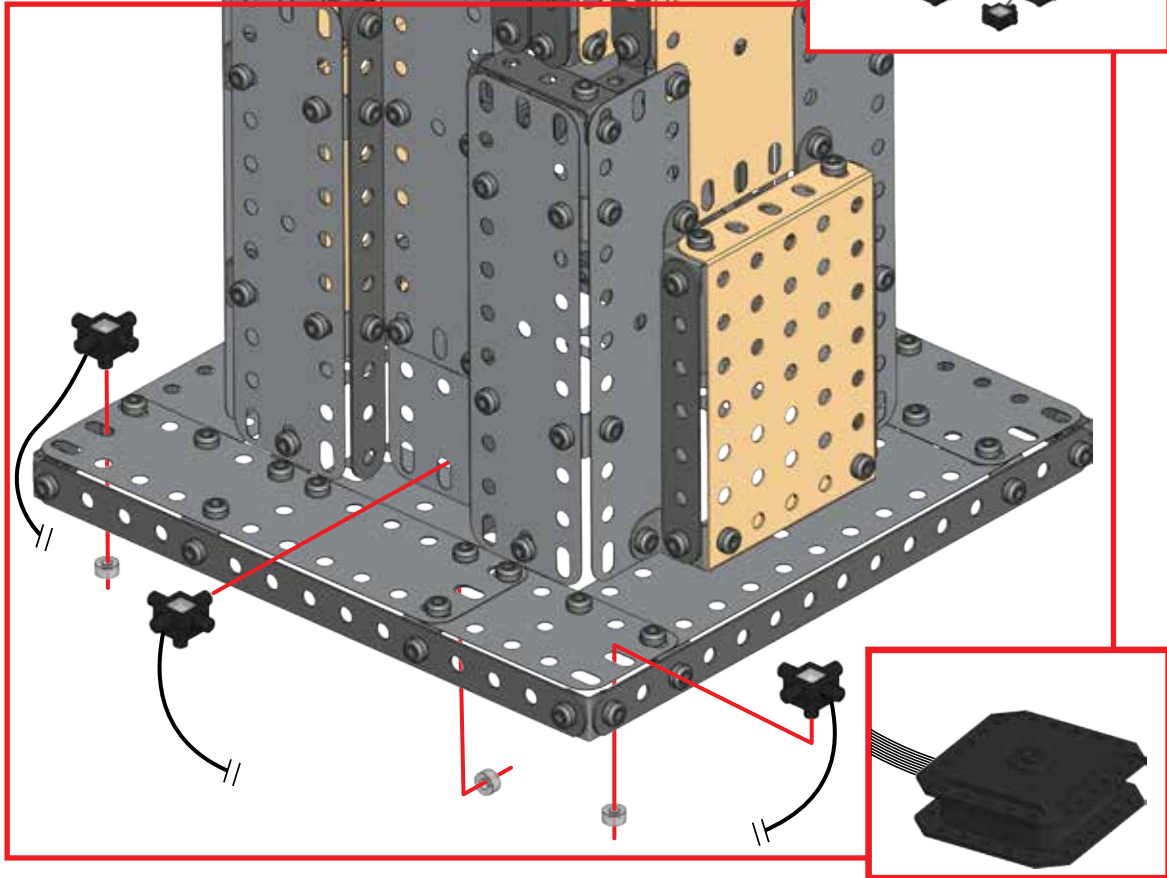
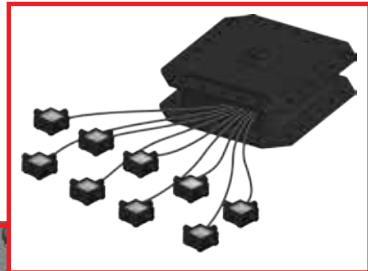
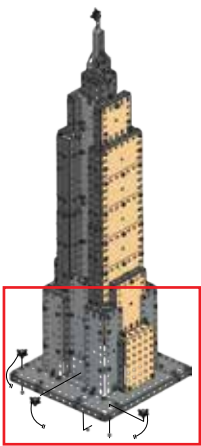

126

 **x3**
|  **x3**



127

-  x3
-  x3

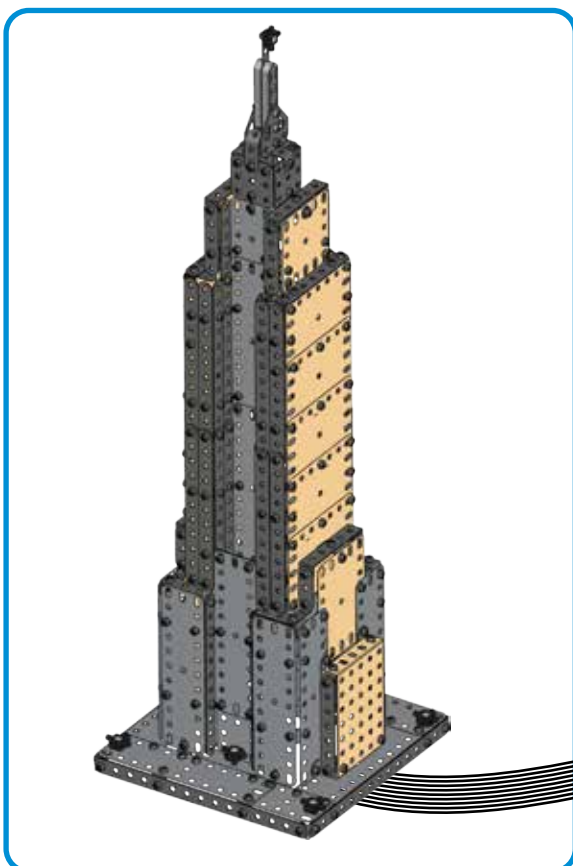
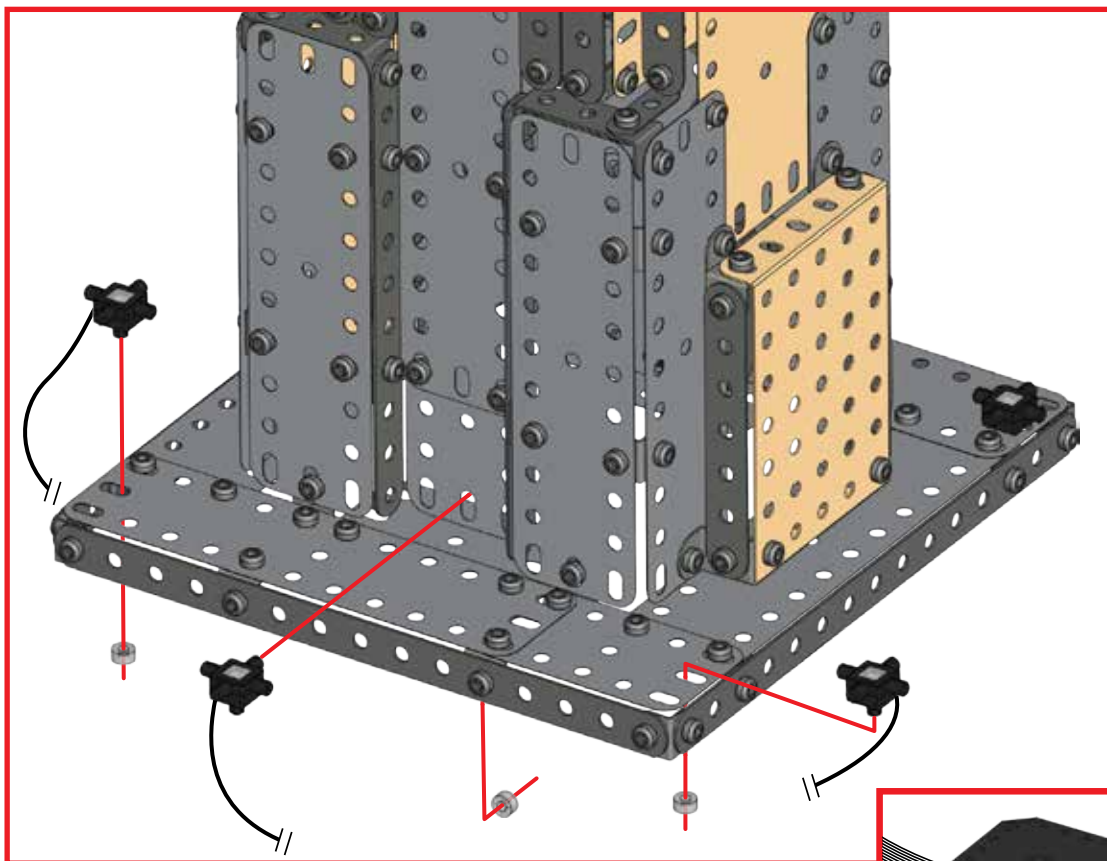

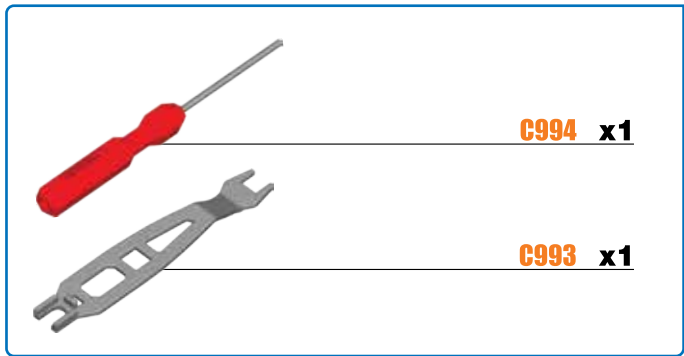
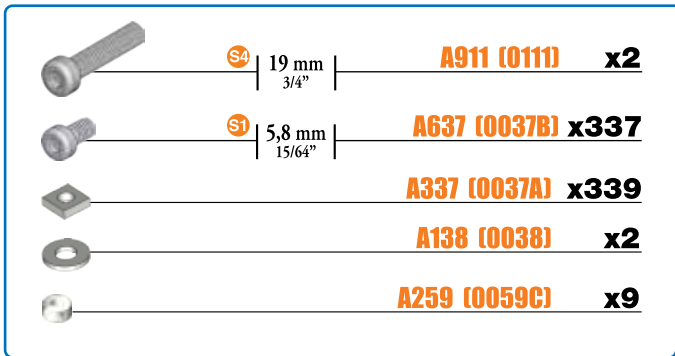
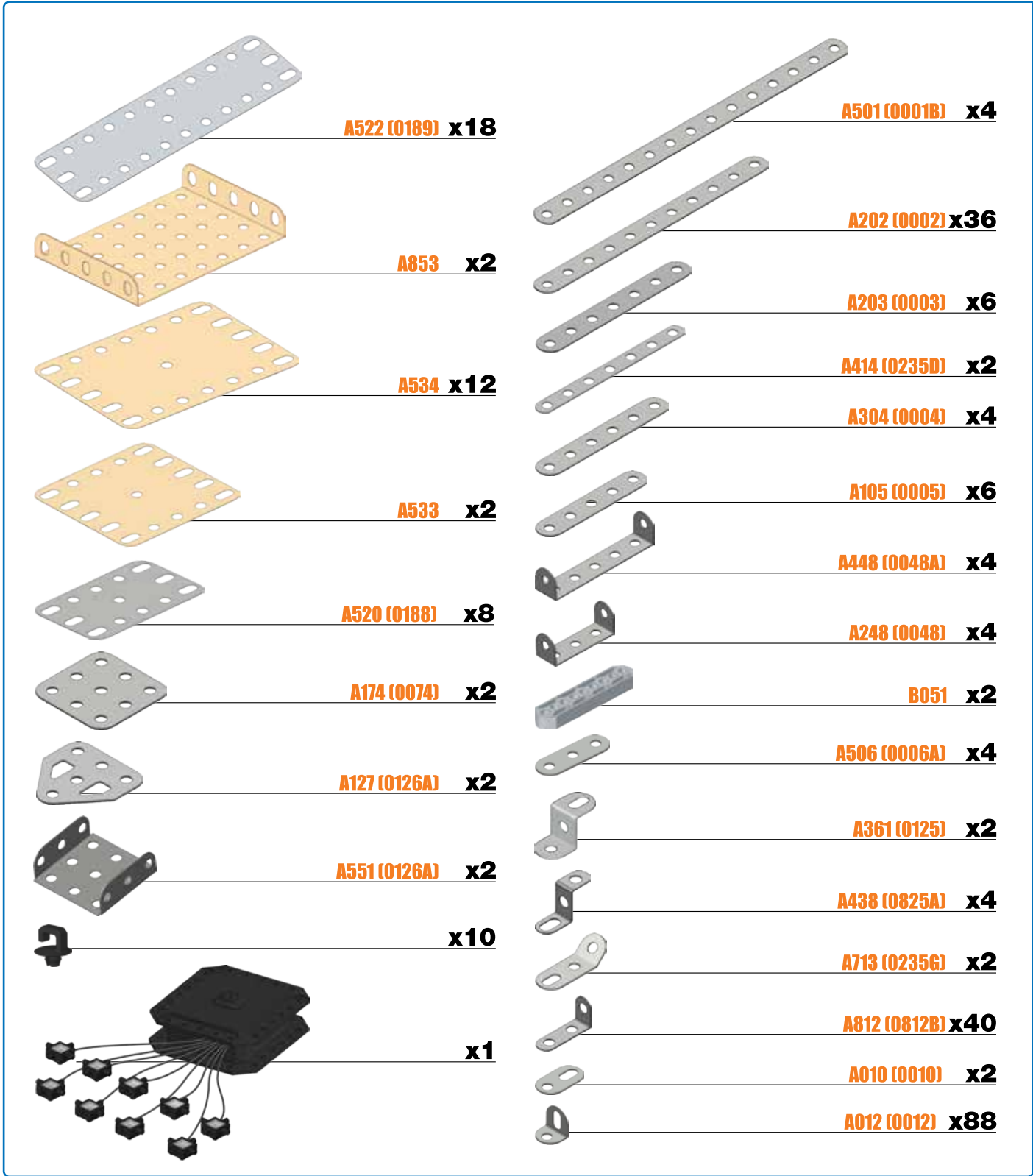

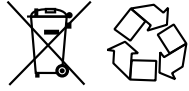

GB/USA When this product has reached the end of its useful life it should not be disposed of with other household waste. The Waste Electrical and Electronic Equipment Regulations require it to be separately collected so that it can be treated using the best available recovery and recycling techniques. This will minimize the impact on the environment and human health from soil and water contamination by any hazardous substances, decrease the resources required to make new products and avoid using up landfill space. Please do your part by keeping this product out of the municipal waste stream! The "wheeler bin" symbol means that it should be collected as "waste electrical and electronic equipment". You can return an old product to your retailer when you buy a similar new one. For other options, please contact your local council.

F Lorsque ce produit arrive en fin de vie, il ne doit pas être jeté avec le reste des déchets ménagers. Conformément à la directive sur les Déchets des équipements électriques et électroniques (DEEE), il doit être collecté séparément afin d'être éliminé selon les meilleures techniques de récupération et de recyclage disponibles. Cette démarche réduit les risques de pollution du sol et des eaux, et permet ainsi de minimiser l'impact de toute substance nocive sur la santé et sur l'environnement. Cela diminue également la quantité de ressources nécessaires à la fabrication de nouveaux produits, et évite la saturation des sites d'enfouissement. Veuillez apporter votre contribution en ne jetant pas ce produit avec les déchets de votre commune. Le symbole de la « poubelle sur roues » signifie que ce produit doit faire l'objet d'une collecte respectant la directive sur les Déchets des équipements électriques et électroniques (DEEE). Vous pouvez également retourner les produits en fin de vie à votre détaillant lors de l'achat d'un produit similaire neuf. Pour plus d'informations, contactez votre commune.

E Cuando este producto alcance el final de su vida útil, no lo deseches como residuo doméstico. La normativa exige que se recoja de forma separada para que pueda tratarse con las mejores técnicas de recuperación y reciclaje disponibles. De esta forma, se minimizará el impacto que la contaminación del suelo y el agua causada por sustancias peligrosas tiene sobre el medio ambiente y la salud humana, se reducirán los recursos necesarios para fabricar nuevos productos y se evitará la saturación de los vertederos. ¡Colabora desechando este producto de forma adecuada! El símbolo del contenedor con ruedas significa que debería recogerse como residuo de aparatos eléctricos y electrónicos. Puedes devolver un producto antiguo en tu establecimiento habitual cuando adquieras un producto nuevo similar. Si deseas obtener más información, consulta con las autoridades locales.

D Ist das Gerät nicht mehr zu gebrauchen, darf es nicht über den Hausmüll entsorgt werden. Die Elektroaltgeräteverordnung (EAG-VO) sieht vor, dass das Gerät separat entsorgt wird, damit es so weit wie möglich recycelt werden kann. Dadurch lassen sich die Menge an umwelt- und gesundheitsschädlichen Substanzen, die über den Boden und das Grundwasser in den menschlichen Nahrungskreislauf gelangen könnten, minimieren, die für die Herstellung neuer Produkte erforderlichen Ressourcen reduzieren und Platz auf Mülldeponien sparen. Leisten Sie bitte Ihren Beitrag dazu, indem Sie das Gerät nicht über den Hausmüll entsorgen. Das Mülltonnen-Symbol bedeutet, dass das Gerät gemäß den Vorschriften für Elektro- und Elektronikgeräte entsorgt werden muss. Alte Geräte können oft beim Kauf eines neuen, ähnlichen Geräts im Einzelhandel zurückgegeben werden. Weitere Entsorgungsmöglichkeiten erfragen Sie bitte bei Ihrer Gemeindeverwaltung.

NL Wanneer dit product het einde van zijn levensduur heeft bereikt, mag het niet samen met ander huishoudelijk afval weggegooid. Volgens de wet moet het afzonderlijk worden ingezameld zodat het kan worden behandeld met de best beschikbare recyclingtechnieken. Op deze manier wordt de invloed op het milieu en de menselijke gezondheid van grond- en watervervuiling door gevaarlijke stoffen geminimaliseerd, hoeven er minder bronnen te worden gebruikt om nieuwe producten te maken en raken stortplaatsen minder snel vol. Draag je steentje bij door dit product uit de gemeentelijke afvalstroom te houden! Het afvalcontainersymbool betekent dat het product moet worden ingezameld als elektrische en elektronische afvalapparatuur. Je kunt een oud product inruilen bij de detailhandelaar wanneer je een vergelijkbaar nieuw product koopt. Neem voor andere opties contact op met de gemeente.

I Il simbolo del cassonetto barrato riportato sull'apparecchiatura indica che il prodotto alla fine della propria vita utile deve essere raccolto separatamente dagli altri rifiuti. L'utente dovrà, pertanto, conferire l'apparecchiatura integra dei componenti essenziali giunta a fine vita agli idonei centri di raccolta differenziata dei rifiuti elettrici ed elettronici, oppure riconsegnarla al rivenditore al momento dell'acquisto di una nuova apparecchiatura di tipo equivalente, in ragione di uno a uno. L'adeguata raccolta differenziata per l'avvio successivo dell'apparecchiatura dimessa al riciclaggio, al trattamento e allo smaltimento ambientale compatibile contribuisce ad evitare possibili effetti negativi sull'ambiente e sulla salute e favorisce il riciclo dei materiali di cui è composta l'apparecchiatura. Lo smaltimento abusivo del prodotto da parte dell'utente comporta l'applicazione delle sanzioni amministrative di cui al D.Lgs n.152/2006 (parte 4 art.255).

P Quando este produto alcançar o fim da sua vida útil não deverá ser eliminado junto dos resíduos domésticos. Por lei, deverá ser recolhido em separado para posterior tratamento usando as melhores técnicas de recuperação e reciclagem disponíveis. Desta forma, minimiza-se o impacto no ambiente e saúde humana da contaminação do solo e água por substâncias perigosas, diminui-se os recursos necessários para fabricar novos produtos e evita-se o esgotamento do espaço em aterros sanitários. Colabore mantendo este produto fora da rede de recolha de resíduos urbanos! O símbolo de "caixote de lixo móvel" significa que o produto deverá ser recolhido como "resíduo de equipamento eléctrico e electrónico". Pode devolver um produto antigo à loja quando compra outro semelhante. Contacte as autoridades locais relativamente à disponibilidade de outras opções.

RU По окончании срока эксплуатации не выбрасывайте игрушку вместе с бытовыми отходами. Согласно закону об утилизации электрических и электронных устройств ее необходимо утилизировать отдельным способом, с использованием наиболее подходящих технологий утилизации и переработки. Это позволит снизить негативные последствия для окружающей среды и здоровья человека, уменьшит загрязнение воды и почвы опасными веществами, а также снизит количество ресурсов, необходимых для изготовления новых игрушек и сократит объем мусора на городских свалках. Внесите свой вклад, сохранив город чистым. Значок с изображением перечеркнутой корзины означает, что игрушку следует утилизировать согласно закону об утилизации электрических и электронных устройств. При покупке новой игрушки вы можете вернуть старую в магазин. Чтобы узнать о других возможных вариантах утилизации, обратитесь в местную перерабатывающую организацию.

GB/USA Battery Safety Information: Requires 4xAA/LR6 1.5V alkaline batteries (not included). Batteries are small objects. Replacement of batteries must be done by adults. Follow the polarity (+/-) diagram in the battery compartment. Promptly remove dead batteries from the toy. Dispose of used batteries properly. Remove batteries for prolonged storage. Only batteries of the same or equivalent type as recommended are to be used. DO NOT incinerate used batteries. DO NOT dispose of batteries in fire, as batteries may explode or leak. DO NOT mix old and new batteries or types of batteries (i.e. alkaline/standard). DO NOT use rechargeable batteries. DO NOT recharge non-rechargeable batteries. DO NOT short-circuit the supply terminals.

F Informations de sécurité concernant les piles : Fonctionne avec 4 piles alcalines AA/LR6 1,5 V (non fournies). Les piles sont des objets de petite taille. Le remplacement des piles doit être effectué par un adulte. Respecter le schéma de polarité (+/-) figurant sur le compartiment des piles. Retirer immédiatement toute pile usagée du jouet. Les piles usagées doivent être jetées conformément aux réglementations en vigueur. Retirer les piles lorsque le produit n'est pas utilisé pendant une période prolongée. Utiliser uniquement des piles identiques ou équivalentes à celles recommandées. NE PAS incinérer les piles usagées. NE PAS jeter au feu des piles usagées, car elles risqueraient d'exploser ou de fuir. NE PAS combiner des piles neuves et usagées, ou des piles de types différents (alcalines et standard, par exemple). NE PAS utiliser de piles rechargeables. NE PAS recharger de piles non-rechargeables. NE PAS provoquer de court-circuit sur les bornes d'alimentation.

E Información importante sobre las pilas: Funciona con 4 pilas alcalinas AA/LR6 de 1,5 V (no incluidas). Las pilas son objetos pequeños. Las pilas deben ser sustituidas por un adulto. Siga el esquema de polaridad (+/-) que aparece en el compartimento de las pilas. Retire cuanto antes las pilas gastadas del juguete. Deseche las pilas usadas de manera apropiada. Retire las pilas si se va a guardar el juguete durante un tiempo prolongado. Utilice únicamente pilas del tipo recomendado o de un tipo equivalente. NO incinere las pilas usadas. NO arroje las pilas al fuego, ya que podrían explotar o desprender productos químicos. NO mezcle pilas nuevas con pilas usadas, ni distintos tipos de pilas (p. ej., alcalinas y normales). NO use pilas recargables. NO recargue pilas no recargables. NO cause cortocircuitos en los terminales de las pilas.

D Sicherheitshinweise zu Batterien: Benötigt 4x1,5-V-Alkali-Mignonzellen (AA/LR6) (nicht enthalten). Batterien sind kleine Gegenstände. Batterien müssen von Erwachsenen ausgewechselt werden. Das Polaritätsdiagramm (+/-) im Batteriefach beachten. Leere Batterien sofort aus dem Spielzeug entfernen. Verbrauchte Batterien ordnungsgemäß entsorgen. Bei längerfristiger Lagerung Batterien vorher entfernen. Nur dieselben oder gleichwertige Batterien wie empfohlen verwenden. Verbrauchte Batterien NICHT verbrennen. Batterien NICHT in Feuer entsorgen, da sie explodieren oder auslaufen könnten. Alte und neue Batterien oder verschiedene Batterietypen (z. B. Alkali/Standard) NICHT zusammen einlegen. KEINE aufladbaren Batterien verwenden. Nicht-aufladbare Batterien NICHT aufladen. Batteriepole NICHT kurzschließen.

NL Veiligheidsinformatie voor de batterijen: Informatie over batterij: Vereist 4 AA-alkalinebatterijen van 1,5 V (LR6) (niet inbegrepen). Batterijen zijn kleine voorwerpen. Het vervangen van batterijen dient door volwassenen te worden gedaan. Houd je aan het polariteitsdiagram (+/-) in het batterijvak. Verwijder lege batterijen onmiddellijk uit het speelgoed. Zorg voor een milieuvriendelijke afvalverwerking van de batterijen. Verwijder de batterijen als het speelgoed voor langere tijd wordt opgeborgen. Alleen batterijen van het aanbevolen type of een equivalent daarvan mogen worden gebruikt. Steek gebruikte batterijen NOOIT in brand. Gooi batterijen NOOIT in vuur. Hierdoor kunnen deze ontploffen of gaan lekken. Gebruik oude en nieuwe batterijen of verschillende typen batterijen (bijv. alkaline/standaard) NOOIT door elkaar. Gebruik GEEN oplaadbare batterijen. Laad niet-oplaadbare batterijen NOOIT op. Veroorzaak NOOIT kortsluiting tussen de contactpunten.

I Informazioni di sicurezza per le pile: Richiede 4 pile alcaline AA/LR6 da 1,5V (non incluse). Le pile sono oggetti di piccole dimensioni. Le pile devono essere sostituite da adulti. Seguire il diagramma della polarità (+/-) nello scomparto pile. Rimuovere rapidamente le pile scariche dal giocattolo. Sostituire correttamente le pile usate. Rimuovere le pile quando il prodotto non deve essere usato per periodi prolungati. Usare solo pile del tipo consigliato o di tipo equivalente. NON bruciare le pile usate. NON smaltire le pile usate nel fuoco: potrebbero esplodere o lasciar fuoriuscire il contenuto. NON mischiare pile vecchie e nuove o tipi di pile diverse (ad esempio alcaline e standard). NON usare pile ricaricabili. NON ricaricare pile non ricaricabili. NON cortocircuitare i terminali delle pile.

P Informação de segurança das pilhas: Requer 4 pilhas alcalinas AA/LR6 de 1.5V (não incluídas). As pilhas são objectos pequenos. A substituição das pilhas deverá ser feita por um adulto. Deverá seguir-se a indicação da polaridade (+/-) no compartimento das pilhas. As pilhas gastas deverão ser imediatamente retiradas do brinquedo. As pilhas usadas deverão ser correctamente descartadas. Remover as pilhas durante períodos prolongados de armazenamento. Deverão utilizar-se apenas pilhas do mesmo tipo (ou de um tipo equivalente) ao recomendado. NÃO incinerar pilhas usadas. NÃO eliminar pilhas em fogo, pois podem explodir ou verter. NÃO combinar pilhas usadas e novas ou tipos de pilhas (p. ex.: alcalinas/padrão). NÃO usar pilhas recarregáveis. NÃO recarregar pilhas não recarregáveis. NÃO provocar curto-circuito dos terminais de alimentação.

R Информация о технике безопасности при эксплуатации элементов питания: Для работы требуются 4 щелочных элемента питания типа AA/LR6 1,5 В (не входят в комплект). Элементы питания представляют собой миниатюрные предметы. Замену элементов питания должны выполнять взрослые. Соблюдайте полярность (+/-), указанную в отсеке элементов питания. Не оставляйте разрядившиеся элементы питания в игрушке. Утилизируйте элементы питания надлежащим образом. Извлекайте элементы питания, если игрушка не используется долгое время. Рекомендуется использовать элементы питания одного или эквивалентного типа. НЕ сжигайте использованные элементы питания. НЕ бросайте элементы питания в огонь. Это может привести к их утечке или взрыву. НЕ используйте новые элементы питания в сочетании с использованными или элементами питания разного типа (т.е. щелочные/обычные). НЕ используйте перезаряжаемые элементы питания. ЗАПРЕЩАЕТСЯ заряжать перезаряжаемые элементы питания. ИЗБЕГАЙТЕ короткого замыкания источников питания.

GB. Remove all packaging before use. Retain this information, addresses and phone numbers for future reference. Content may vary from pictures. Meccano reserves the right to discontinue the website www.meccano.com at any time. An adult should periodically check this toy to ensure no damage or hazard exist if so, remove from use. Children should be supervised during play.

F. Retirer tout l'emballage avant utilisation. Conserver les informations, adresses et numéros de téléphone pour consultation ultérieure. Le contenu peut différer des images. Meccano se réserve le droit de supprimer le site Internet www.meccano.com à tout moment. Un adulte doit régulièrement examiner ce jouet afin de s'assurer qu'il ne présente pas de dommage ni de risque. En cas de problème, ne plus l'utiliser. Les enfants doivent être surveillés lorsqu'ils jouent.

E. Retire todo el embalaje antes de utilizar el producto. Conserve toda la información, las direcciones y los números de teléfono para futuras referencias. El contenido del paquete puede no corresponder con las imágenes. Meccano se reserva el derecho a suspender el sitio web www.meccano.com en cualquier momento. Un adulto debe revisar de forma periódica el juguete para asegurarse de que no supone un riesgo o peligro para el niño; si así fuera el caso, interrumpa su uso. Supervise a los niños mientras juegan con el producto.

D. Entfernen Sie vor der Benutzung sämtliche Verpackungsmaterialien. Alle Informationen, Adressen und Telefonnummern bitte für mögliche Rückfragen aufbewahren. Der Packungsinhalt kann von den Bildern abweichen. Meccano behält sich das Recht vor, den Betrieb der Website www.meccano.com jederzeit einzustellen. Ein Erwachsener sollte regelmäßig sicherstellen, dass das Spielzeug keine Gefahr darstellt, und es gegebenenfalls entfernen. Kinder sollten beim Spielen beaufsichtigt werden.

NL. Verwijder de verpakking voor gebruik. Bewaar deze informatie, adressen en telefoonnummers voor toekomstig gebruik. Inhoud kan afwijken van illustraties.

Meccano behoudt zich het recht voor de website www.meccano.com wanneer gewenst buiten gebruik te stellen. Een volwassene dient dit speelgoed regelmatig te controleren op schade en gevaren. Indien het speelgoed is beschadigd of indien er een gevaarlijke situatie kan ontstaan, dient het product te worden weggegooid. Houd toezicht als kinderen spelen.

I. Rimuovere l'imballo prima dell'uso. Conservare informazioni, indirizzi e numeri di telefono per riferimento futuro. Il prodotto potrebbe essere differente dalle immagini. Meccano si riserva il diritto di rimuovere il sito www.meccano.com in qualsiasi momento. È consigliabile un controllo periodico del giocattolo da parte di un adulto: in caso di danni o rischi interrompere l'uso. È richiesta la supervisione di un adulto durante il gioco.

P. Remova totalmente a embalagem antes de utilizar. Guarde todos os endereços, números de telefone e demais informações para consulta e referência. O conteúdo poderá ser diferente das ilustrações. A Meccano reserva-se o direito de descontinuar o site www.meccano.com a qualquer altura. Um adulto deve verificar o brinquedo periodicamente para garantir que ele não apresenta danos ou riscos. Se houver, é necessário que o brinquedo seja retirado de uso. Crianças devem ser supervisionadas enquanto brincam.

R. Снимите все упаковочные материалы перед использованием. Запишите указанные на упаковке адреса и номера телефонов, чтобы у вас была возможность связаться с нами. Содержимое упаковки может отличаться от иллюстрации. Компания Meccano оставляет за собой право прекратить использование сайта www.meccano.com в любое время. Регулярно проверяйте состояние игрушки на наличие повреждений и возможных рисков для ребенка. Если таковые имеются, игрушку не следует использовать. Во время игры за детьми следует присматривать.

- ⚠ Warning: CHOKING HAZARD – Small parts.
- ⚠ Attention ! RISQUE D'ETOUFFEMENT – Contient de petits éléments.
- ⚠ Advertencia: PELIGRO DE ASFIXIA – Contiene piezas pequeñas No conveniente para niños menores de 3 años.
- ⚠ Achtung: ERSTICKUNGSGEFAHR – Kleinteile.
- ⚠ Waarschuwing: VERSTIKKINGSGEVAAR – Kleine onderdelen.
- ⚠ Attenzione: RISCHIO DI SOFFOCAMENTO – Pezzi piccoli.
- ⚠ Aviso: PERIGO DE ASFIXIA – Peças pequenas.
- ⚠ Осторожно! ОПАСНОСТЬ УДУШЬЯ – Мелкие детали.



UK – 0800 206 1191, SERVICEUK@SPINMASTER.COM
FRANCE – 0800 909 150, SERVICEFR@SPINMASTER.COM
ESPAÑA – SERVICIO@SPINMASTER.COM
DEUTSCHLAND – 00800 0101 0222, KUNDENSERVICE@SPINMASTER.COM
SCHWEIZ – 0800 561 350 • ÖSTERREICH – 0800 29 72 67
NEDERLAND – 0800 022 36 83, KLANTENSERVICE@SPINMASTER.COM
BELGIË/BELGIQUE – 0800 77 688 • LUXEMBOURG – 800 28 044
ITALIA – 800 788 532, SERVIZIO@SPINMASTER.COM
MEXICO – 53.51.44.00
WWW.SPINMASTER.COM



NORTH AMERICA : 1-800-622-8339 customer@spinmaster.com
AMÉRIQUE DU NORD :



SPIN MASTER LTD., 450 FRONT STREET WEST, TORONTO, ON M5V 1B6 CANADA.

Distributed in EU by SPIN MASTER INTERNATIONAL, S.A.R.L.,
16 AVENUE PASTEUR, L-2310,
Luxembourg. www.spinmaster.com

Made in France by / Fabriqué en France par / Hecho en Francia por
Meccano : 363, avenue de Saint-Exupéry 62100 Calais - France

T91761_0003_20068853_GML_IB_R1_MEC_Empire state_FR

TM & © 2015 MECCANO for packaging, instructions and models built with this set. TM & © 2015 MECCANO pour l'emballage, les notices et modèles de ce coffret. ® MECCANO is an exclusive trademark of MECCANO. Spin Master logo is a trademark of Spin Master Ltd. ® MECCANO est une marque de commerce exclusive de MECCANO. Le logo de Spin Master est une marque de commerce de Spin Master Ltd. All rights reserved. Tous droits réservés.