

10+

Years/Ans/Años  
Jahre/Jaar/Anni  
Anos/Лет



## MECCANOID G15

PERSONAL ROBOT

For instructions in other languages, visit [www.meccano.com](http://www.meccano.com)

- INSTRUCTION GUIDE
- MODE D'EMPLOI
- GUÍA DE INSTRUCCIONES
- BEDIENUNGSANLEITUNG
- GEBRUIKSAANWIJZING
- GUIDA PER L'USO
- GUIA DE INSTRUÇÕES
- ИНСТРУКЦИЯ ПО ИСПОЛЬЗОВАНИЮ

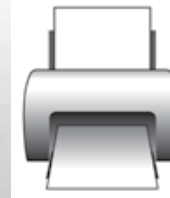

- (FR) Merci d'imprimer à échelle 1 sans les marges de l'imprimante.
- (GB) Please print at scale 1 without the printer margins.
- (D) Den Maßstab 1 bitte randlos drucken.
- (IT) Stampare la scala 1 senza i margini della stampante.
- (E) Imprimir a escala 1 sin los márgenes de la impresora.
- (P) É favor imprimir escala 1 sem as margens da impressora.
- (S) Skriv ut i skala 1 utan skrivarens marginaler.
- (FIN) Portaiden painatuksen jälkeen reunat eivät saa näkyä.
- (DK) Udskriv venligst i målestoksforhold 1 uden printermarginer.
- (NL) É favor imprimir escala 1 sem as margens da impressora.
- (GR) Σας παρακαλώ τυπώστε την κλίμακα 1 μέσα στα περιθώρια του εκτυπωτή.
- (R) Пожалуйста, печатайте в масштабе 1:1 без отступов от края.

For instructions in other languages, visit [www.meccano.com](http://www.meccano.com)

Pour télécharger les instructions dans une autre langue, rends-toi sur [www.meccano.com](http://www.meccano.com)

Para consultar las instrucciones en otros idiomas, visita [www.meccano.com](http://www.meccano.com)

Eine detaillierte Bedienungsanleitung in deutscher Sprache findest du auf [www.meccano.com](http://www.meccano.com).

Voor instructies in andere talen, bezoek [www.meccano.com](http://www.meccano.com)

Per le istruzioni in altre lingue, visitare il sito [www.meccano.com](http://www.meccano.com)

Para instruções em outros idiomas, acesse [www.meccano.com](http://www.meccano.com)

Инструкции на других языках можно найти на сайте [www.meccano.com](http://www.meccano.com)

4x C/LR141-5V  
BATTERIES NOT INCLUDED / PILLES NON FOURNIES / PILAS NO INCLUIDAS / BATTERIEN NIET INGELOEPEN / BATTERIEN NIET INBEGREPEN / BATTERIE NON INCLUSE / PILHAS NÃO INCLUIDAS / Батареи не входят в комплект

BC

- ⚠ **WARNING:** Cords could be a strangulation hazard. Not for use by children under 3 years of age.
- ⚠ **ATTENTION!** Les câbles peuvent présenter un risque de strangulation. Ne pas laisser à la portée des enfants de moins de 3 ans.



UK - 0800 206 1191, [serviceuk@spinmaster.com](mailto:serviceuk@spinmaster.com)  
 FRANCE - 0800 909 150, [servicefr@spinmaster.com](mailto:servicefr@spinmaster.com)  
 ESPAÑA - [servicio@spinmaster.com](mailto:servicio@spinmaster.com)  
 DEUTSCHLAND - 0800 0101 0222, [kundenservice@spinmaster.com](mailto:kundenservice@spinmaster.com)  
 SCHWEIZ - 0800 561 350 • ÖSTERREICH - 0800 29 72 67  
 Nederland - 0800 022 36 83, [klanten service@spinmaster.com](mailto:klanten service@spinmaster.com)  
 BELGIË/BELGIQUE - 0800 77 688 • LUXEMBOURG - 800 28 044  
 ITALIA - 800 788 532, [servizio@spinmaster.com](mailto:servizio@spinmaster.com)  
 MEXICO - (55) 5351-4400

**NORTH AMERICA • AMÉRIQUE DU NORD**  
 1-800-622-8339, [CUSTOMERCARE@spinmaster.com](mailto:CUSTOMERCARE@spinmaster.com)

**FCC Statement:** This device complies with Part 15 of the FCC rules. Operation is subject to the following two conditions: (1) This device may not cause harmful interference, and (2) This device must accept any interference received, including interference that may cause undesired operation. This equipment has been tested and found to comply with the limits for Class B digital devices, pursuant to Part 15 of the FCC rules. These limits are designed to provide reasonable protection against harmful interference to radio communications. This equipment generates, uses and can radiate radio frequency energy and, if not installed and used in accordance with the instruction, may cause harmful interference to radio communication. However, there is no guarantee that interference will not occur in a particular installation. If this toy does cause interference to radio or television reception (you can check this by turning the toy off and on while listening for the interference), one or more of the following measures may be useful: • Reorient or relocate the receiving antenna • Increase the separation between the toy and the radio or the TV • Consult the dealer or an experienced TV-radio technician for help. Shielded cables must be used with this unit to ensure compliance with the Class B FCC limits. Shielded cables must be used with this unit to ensure compliance with the Class B FCC limits. **NOTE:** Changes, adjustments or modifications to this unit, including but not limited to, replacement of any transmitter component (crystal, semiconductor, etc) could result in a violation of FCC rules under part 15 and/or 95 and must be expressly approved by Spin Master Ltd or they could void the user's authority to operate the equipment.

**Déclaration de la FCC :** Le présent appareil est conforme à l'article 15 de la réglementation de la FCC. L'utilisation est autorisée aux deux conditions suivantes : (1) l'appareil ne doit pas produire de brouillage, et (2) l'appareil doit accepter tout brouillage radioélectrique subi, même si le brouillage est susceptible d'en compromettre le fonctionnement. Cet équipement a été testé et jugé conforme aux limites de la classe B pour les équipements numériques en vertu de l'article 15 de la réglementation de la FCC. Ces limites ont été instaurées pour assurer une protection raisonnable contre toute interférence nuisible avec les communications radio. Cet équipement génère, utilise et peut émettre de l'énergie de fréquence radio. S'il n'est pas installé et utilisé selon le mode d'emploi, il peut causer des interférences nuisibles aux communications radio. Cependant, il n'existe aucune garantie contre ces interférences dans le cas où l'installation ne serait pas conforme. Si ce jouet cause des interférences à la réception radio ou télévisée (ce qui est vérifiable en l'éteignant, puis en le rallumant tout en écoutant s'il y a des interférences), suivre une ou plusieurs des recommandations suivantes : • Réorienter ou déplacer l'antenne réceptrice • Augmenter la distance entre le jouet et la radio ou la télévision • Consulter le revendeur ou demander l'aide d'un technicien radio/T.V. expérimenté. Pour respecter les limites de la classe B de la réglementation de la FCC, cet appareil doit être utilisé avec des câbles blindés.

**REMARQUE :** tout changement, réglage ou modification de cet appareil, incluant mais ne se limitant pas au remplacement de tout composant du transmetteur (cristal, semi-conducteur, etc.), pourrait constituer une violation de l'article 15 et/ou 95 de la réglementation de la FCC, et doit être expressément approuvé par Spin Master Ltd., sous peine d'entraîner l'annulation du droit de l'utilisateur d'exploiter l'équipement.

**Declaración de la FCC:** Este dispositivo cumple con la sección 15 de la normativa de la FCC. El funcionamiento está sujeto a estas dos siguientes condiciones: (1) el dispositivo no debe causar interferencias dañinas, y (2) el dispositivo debe admitir la recepción de cualquier tipo de interferencia, incluidas aquellas que puedan causar un funcionamiento indeseado. Este equipo ha sido probado y cumple los límites para dispositivos de clase B digital establecidos en la sección 15 de la normativa de la FCC. Estos límites han sido diseñados para proporcionar una protección razonable contra la interferencia dañina en las comunicaciones por radio. Este equipo genera, utiliza y emite energía en forma de radiofrecuencias, por lo que si no se instala y utiliza como indican las instrucciones, podría provocar interferencias dañinas en comunicaciones de radio. No obstante, no se puede garantizar que no habrá interferencias en una instalación determinada. Si este juguete provoca interferencias en la recepción de radio o televisión (puede comprobarlo apagando y encendiendo el juguete mientras escucha si se producen interferencias), puede tomar alguna de las siguiente medidas: • Reorientar o cambiar de lugar la antena receptora • Aumentar la separación entre el juguete y la radio o el televisor • Consultar con el vendedor o un técnico de televisión y radio si necesita asistencia adicional. Para cumplir con los límites de la clase B de las normas FCC, este aparato se debe utilizar con cables blindados. **NOTA:** Los cambios, los ajustes o las modificaciones realizadas en este dispositivo, como, entre otros, la sustitución de cualquier componente transmisor (cristal, semiconductor, etc.) podría suponer la infracción de las secciones 15 ó 95 de la normativa de la FCC, y debe ser explícitamente aprobada por Spin Master Ltd.; en caso contrario, el usuario podría verse privado del derecho de operar el equipo.

**GB Content:** 615 Parts, 1 MeccaBrain™, 1 LED module, 2 hand tools, 4 servos, 2 rear wheel assembly, 2 motor gear box assembly, 1 USB cable

**F Contenu :** 615 pièces, 1 MeccaBrain™, 1 module LED, 2 outils, 4 servomoteurs, assemblage 2 roues arrière, assemblage 2 moteurs et engrenages, 1 câble USB

**E Contenido:** 615 piezas, 1 MeccaBrain™, 1 módulo LED, 2 herramientas, 4 servos, ensamblaje para 2 ruedas traseras, ensamblaje con 2 motores y caja de engranajes, 1 cable USB

**D Inhalt:** 615 Teile, 1 MeccaBrain™, 1 LED-Modul, 2 Handwerkzeuge, 4 Servos, 2 Hinterräder zum Zusammenbauen, 2 Getriebe zum Zusammenbauen, 1 USB-Kabel

**NL Inhoud:** 615 onderdelen, 1 MeccaBrain™, 1 LED-module, 2 stuks handgereedschap, 4 servo's, 2 achterwielen, 2 motorkasten, 1 USB-Kabel

**I Contenuto:** 615 pezzi, 1 MeccaBrain™, 1 modulo a LED, 2 attrezzi, 4 servomotori, kit con 2 ruote posteriori, kit con 2 motori e cambi di velocità, 1 cavo USB

**P Conteúdo:** 615 partes, 1 MeccaBrain™, 1 módulo de LED, 2 ferramentas manuais, 4 servomotores, 2 rodas traseiras, 2 caixas com 2 engrenagens e motor, 1 cabo USB

**R В коробке:** 615 деталей, 1 MeccaBrain™, 1 светодиодный модуль, 2 ручных инструмента, 4 сервоприводов, комплект из 2 задних колес, комплект из 2 механизированных коробок передач, 1 USB-кабель







### CAN ICES-3 (B)/NMB-3(B)



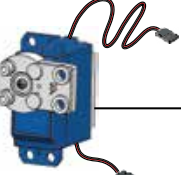

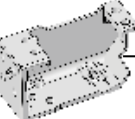
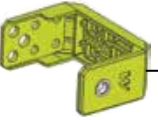





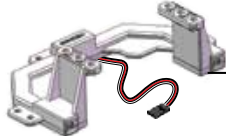

**CANADIAN Class B statement:** This device complies with Industry Canada Licence-exempt RSS-210. Operation is subject to the following two conditions: (1) this device may not cause interference, and (2) this device must accept any interference, including interference that may cause undesired operation of the device.





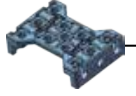







**Déclaration CANADIENNE classe B:** Le présent appareil est conforme au CNR-210 d'Industrie Canada applicable aux appareils radio exempts de licence. L'utilisation est autorisée aux deux conditions suivantes : (1) l'appareil ne doit pas produire de brouillage, et (2) l'appareil doit accepter tout brouillage radioélectrique subi, même si le brouillage est susceptible d'en compromettre le fonctionnement.

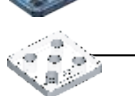









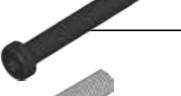



Only one model can be built at a time. / Les pièces fournies ne permettent de monter qu'un seul modèle à la fois. / Solo es posible construir un modelo a la vez. / Jeweils nur eins der Modelle baubar.

Er kan maar een model tegelijk worden gebouwd. / Permette di realizzare un solo modello per volta. / Só é possível montar um modelo de cada vez. / Одновременно можно построить только одну модель.

-  **M102 x1**
-  **M902 x4**
-  **M045R x1**
-  **M045L x1**
-  **M016 x4**
-  **M006 x4**
-  **M905 x1**
-  **M013 x1**
-  **M101 x4**
-  **M100 x4**

-  **M904 x1**
-  **M019 x3**
-  **M119 x3**
-  **M026 x2**
-  **M026 x4**
-  **M020 x1**
-  **M009 x2**
-  **M215 x1**
-  **M027 x6**
-  **M025 x10**
-  **M031 x2**
-  **M212 x2**
-  **M107 x2**

-  **M218 x8**
-  **M018 x1**
-  **M004 x3**
-  **M002 x4**
-  **M010 x4**
-  **M217 x4**
-  **M005 x2**
-  **M003 x6**
-  **M001 x21**
-  **M213 x2**
-  **M007 x2**
-  **M021 x2**
-  **M029 x8**
-  **USB x1**

-  **B4** 38,1 mm | 1 1/2" | **B696 x8**
-  31,75 mm | 1 1/4" | **C935 x2**
-  **S4** 19 mm | 3/4" | **A911 (0111) x19**
-  **B1** 14,7 mm | 37/64" | **A247 (0147D) x4**
-  **S3** 12 mm | 1/2" | **A411 (0111A) x195**
-  **S2** 9,5 mm | 3/8" | **A511 (0111C) x6**
-  **M2** 10,5 mm | 7/16" | **M908 x4**
-  **A337 (0037A) x217**
-  **M907 x14**
-  **M044 x6**
-  **M040 x4**
-  **M201 x4**
-  **C994 x1**
-  **C993 x1**
-  **A136 (0036C) x1**

**2**

 12 mm | 1/2" | **x4**

 **x4**

 **x1**

 **x1**

 S3 | **1:1**

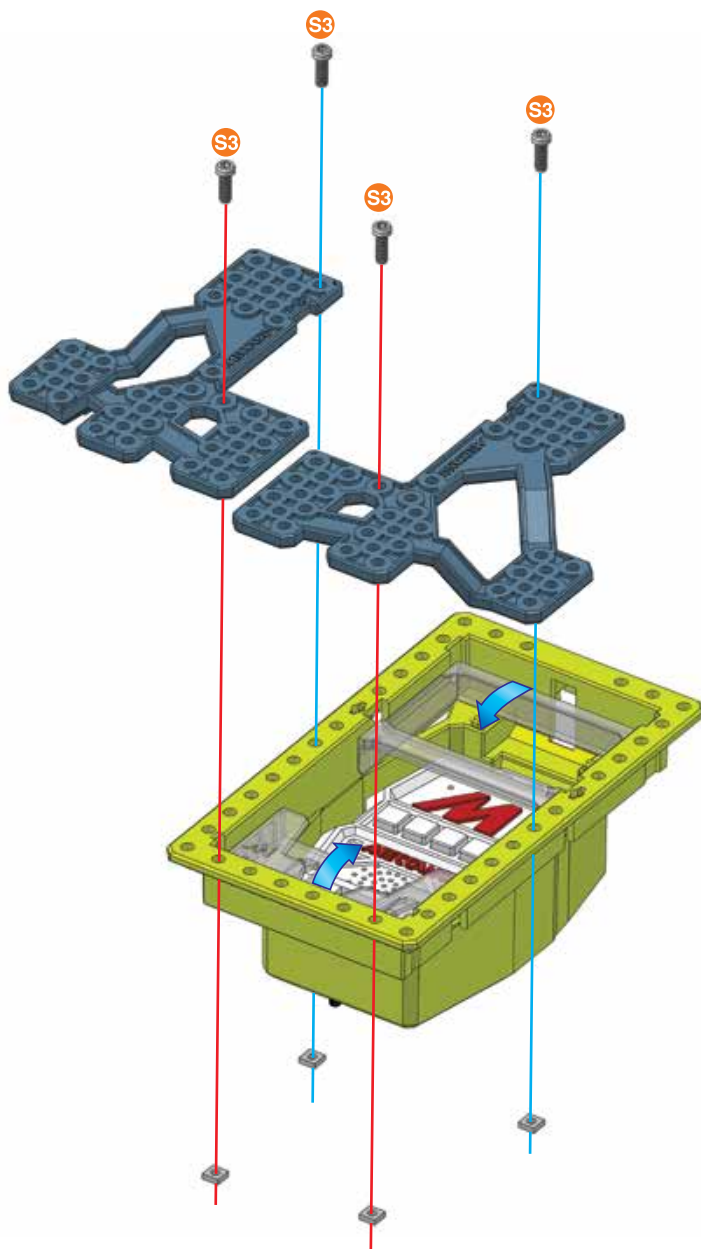

**3**

 12 mm | 1/2" | **x2**

 **x2**

 **x2**

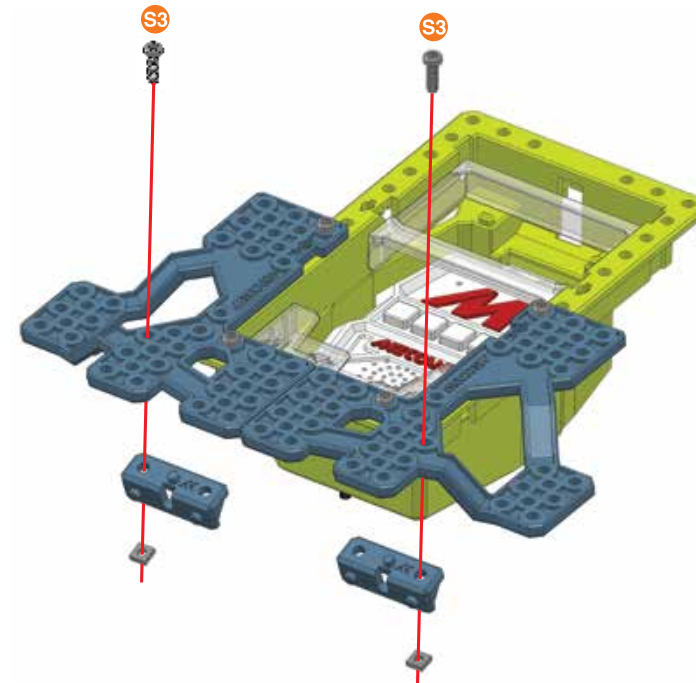

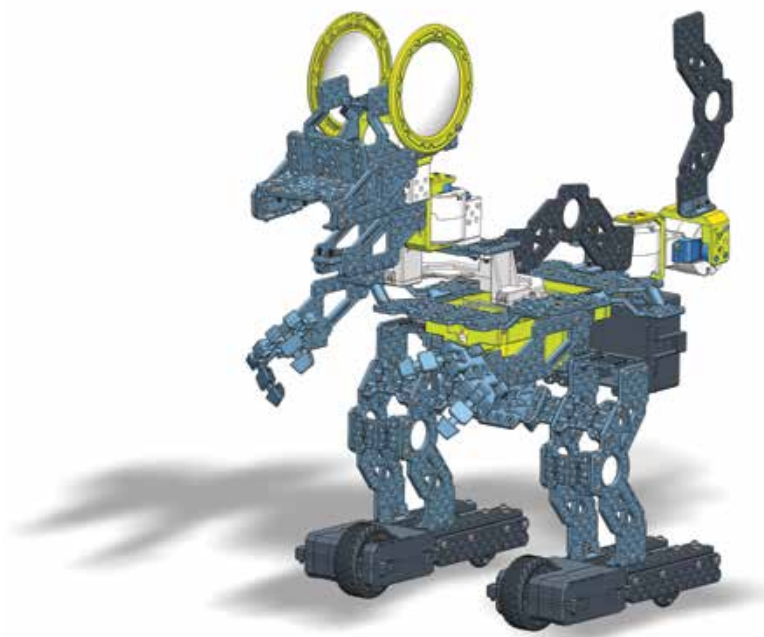

**1**

1:1

x1  
 x1  
 x2  
 x2

Make sure the Meccabrain is in drone mode





Robot Drone

1 2 3 4 5 6 7 8

USB



LAN/ADG BUS/ADG

4

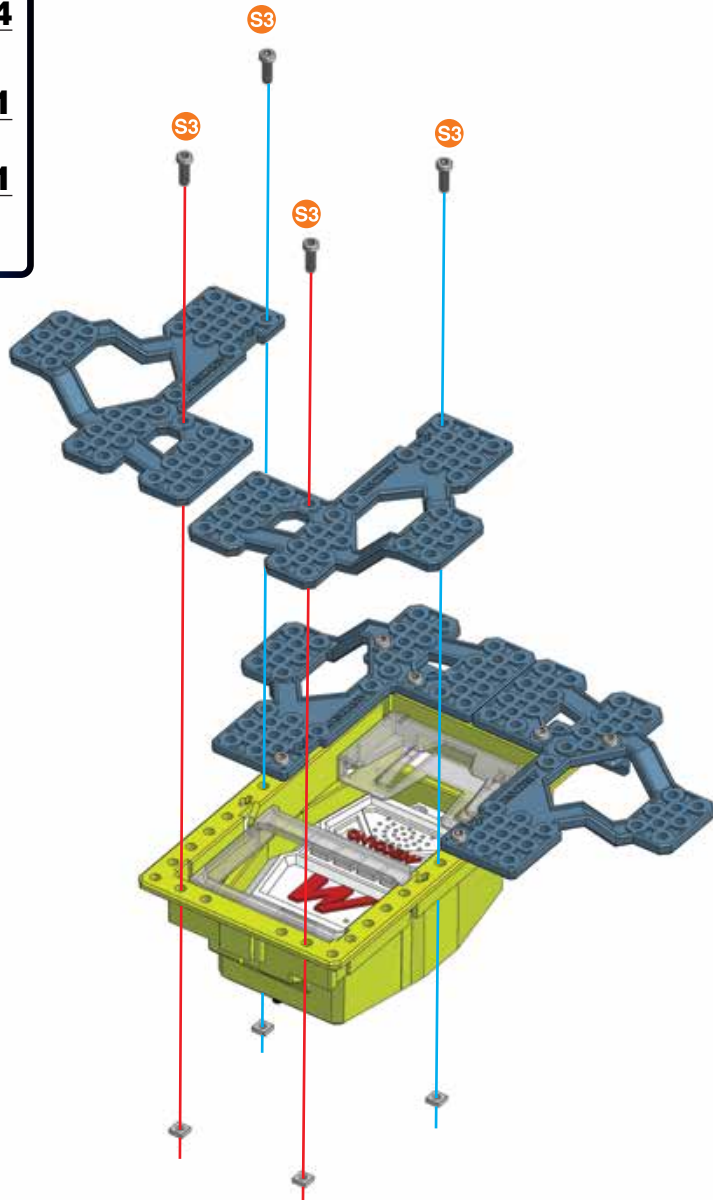
	12 mm 1/2"	x4
		x4
		x1
		x1



5

	12 mm 1/2"	x2
		x2
		x2

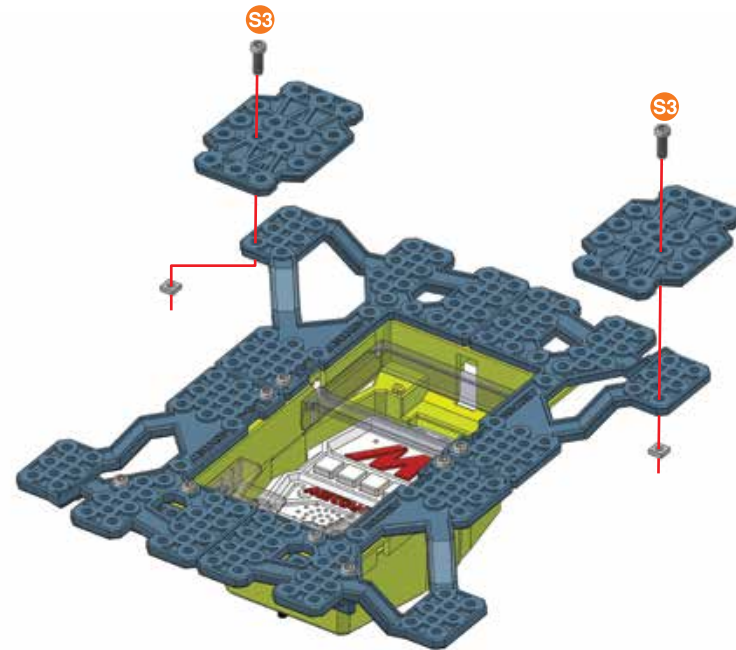
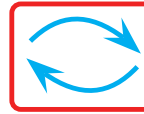

**6**

	12 mm 1/2"	<b>x2</b>
---	---------------	-----------

		<b>x2</b>
---	--	-----------

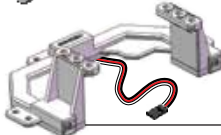
		<b>x1</b>
---	--	-----------

	S3	<b>1:1</b>
---	----	------------

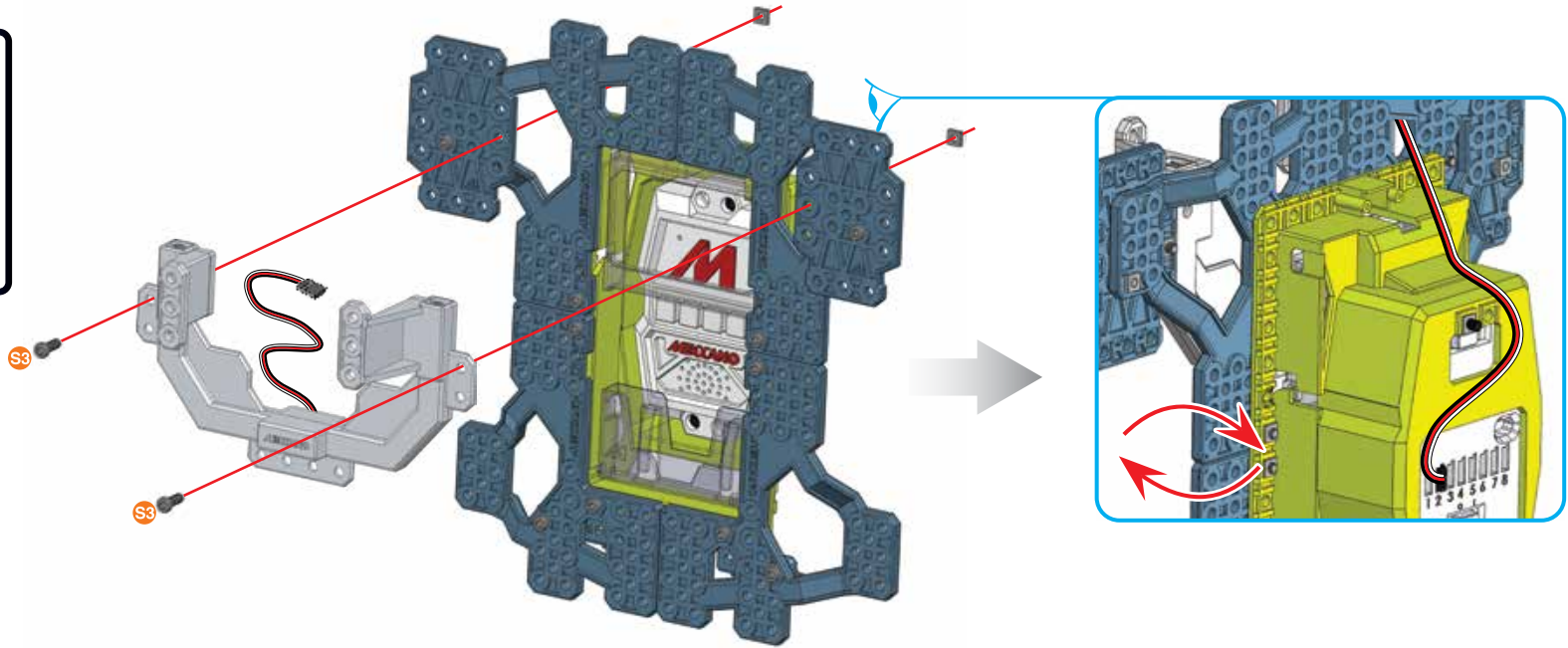
**7**

	12 mm 1/2"	<b>x4</b>
---	---------------	-----------

		<b>x4</b>
---	--	-----------

		<b>x2</b>
--	--	-----------

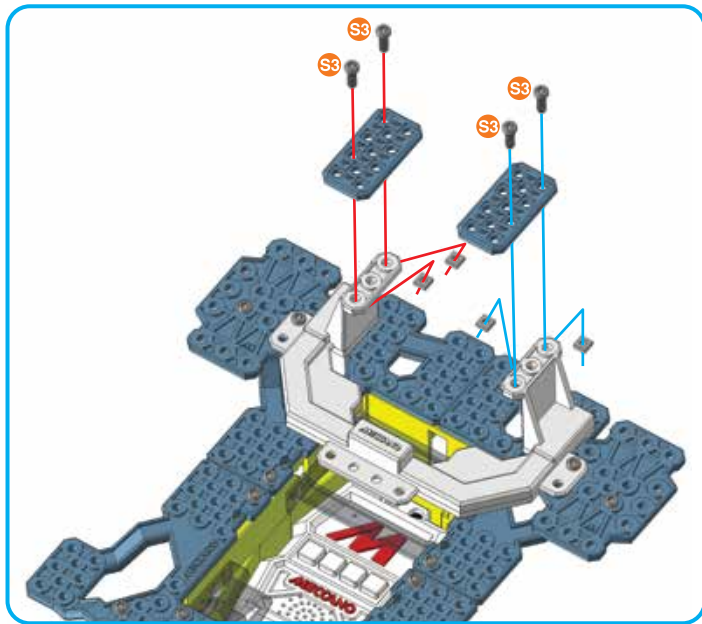
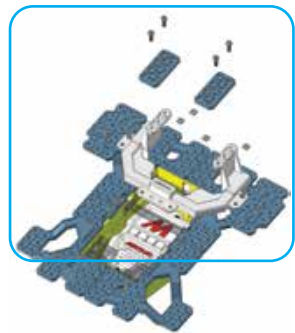
**8**



	12 mm 1/2"	<b>x1</b>
---	---------------	-----------

		<b>x1</b>
---	--	-----------

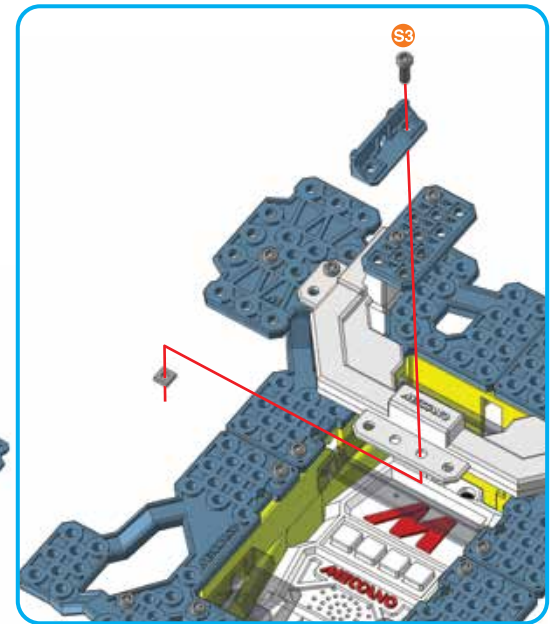
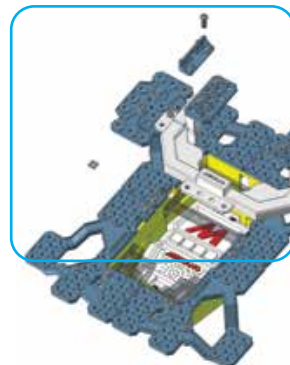
		<b>x1</b>
--	--	-----------



### 9



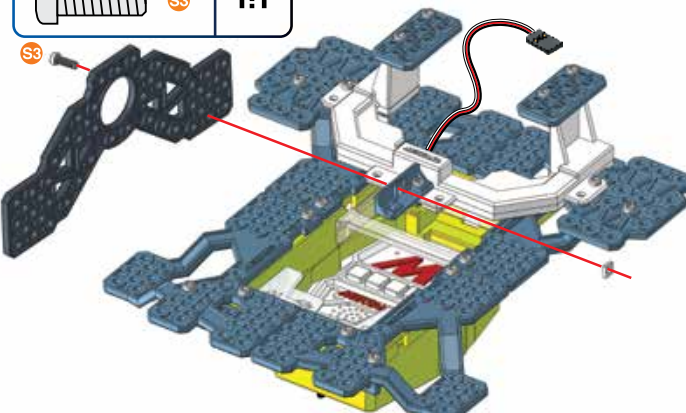

	12 mm 1/2"	<b>x1</b>
		<b>x1</b>

 **x1**

		<b>1:1</b>
---	--	------------





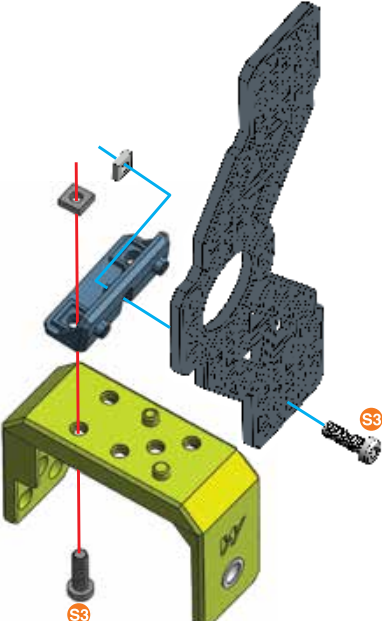

### 10

	12 mm 1/2"	<b>x2</b>
		<b>x2</b>
		<b>x1</b>
		<b>x1</b>
		<b>x1</b>



### 11

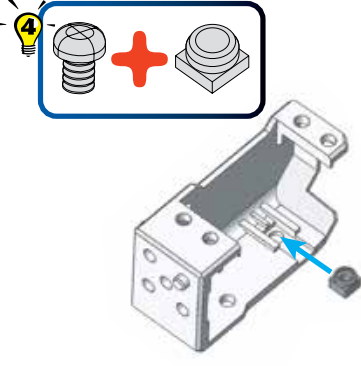

		<b>x3</b>
		<b>x3</b>

**4**   + 



**x3** 

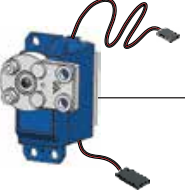

### 12

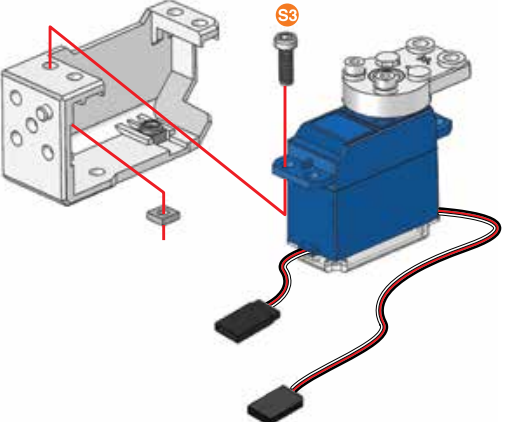
	12 mm 1/2"	<b>x3</b>
		<b>x3</b>
		<b>x3</b>

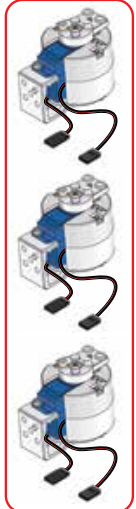

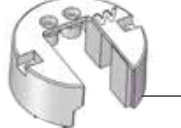

**x3** 

### 13

	19 mm 3/4"	<b>x3</b>
		<b>x3</b>
		<b>x3</b>

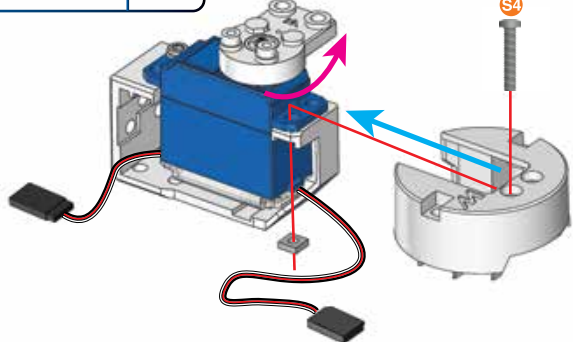

		<b>1:1</b>
---	--	------------



**x3** 

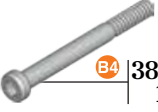

### 14

	B4   38.1mm   1 1/2"	x6
		x6
		x3

**x3**

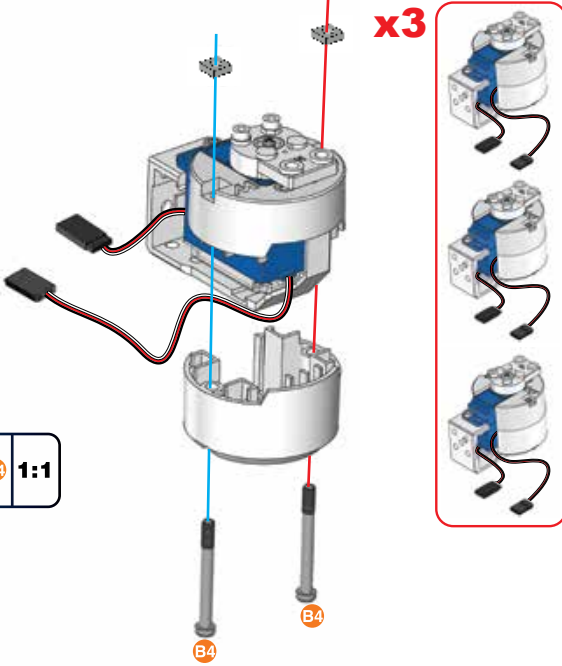

**B4** **1:1**

### 15

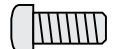
	S2   9.5 mm   3/8"	x1
	S2	1:1

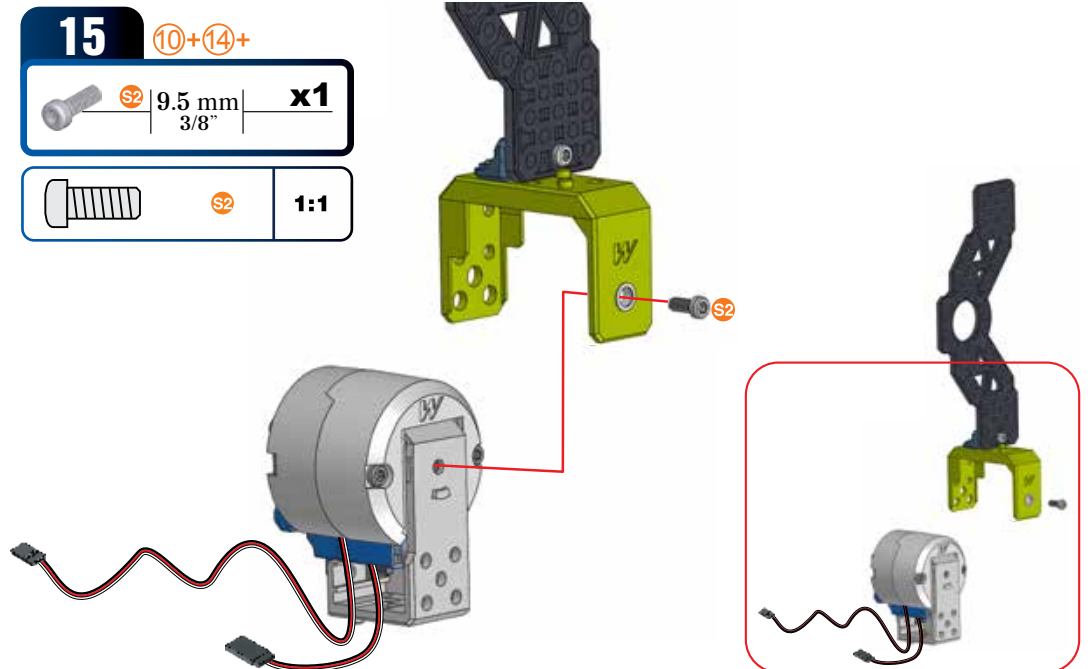

**S2**

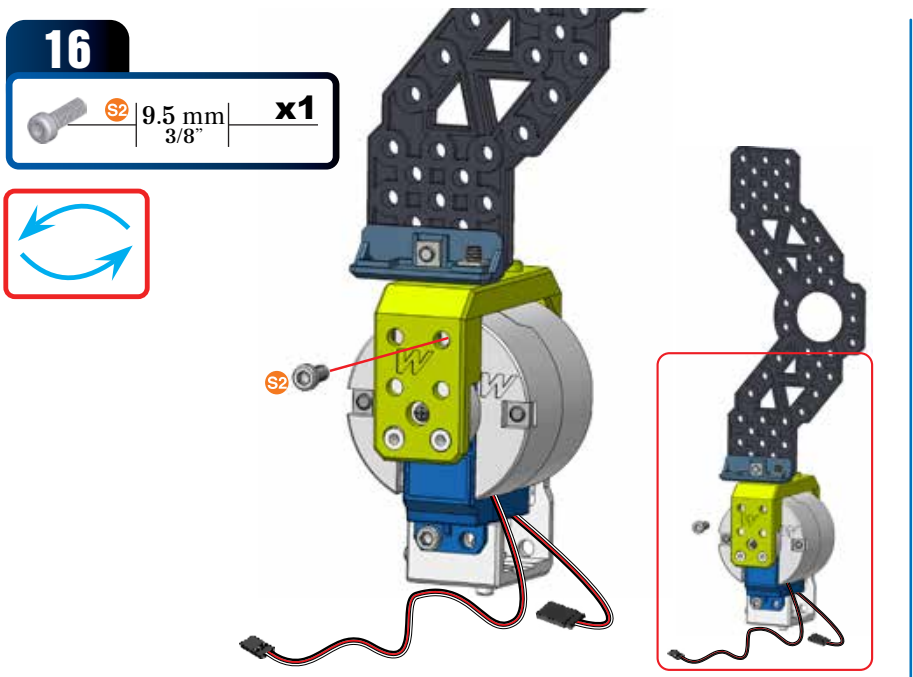

### 16

	S2   9.5 mm   3/8"	x1
---	--------------------	----



**S2**

### 17

	S3   12 mm   1/2"	x1
		x1
		x1

	S3	1:1
---	----	-----

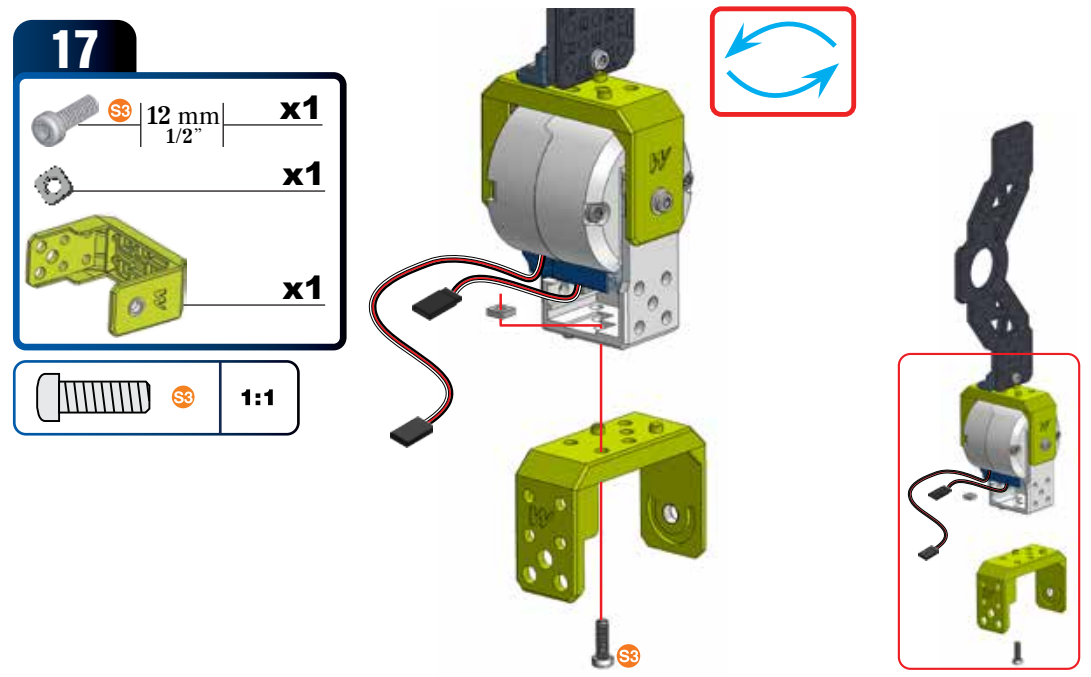

**S3**

18

(14)+(17)+

	S2	9.5 mm 3/8"	x1
---	----	----------------	----

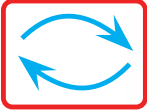

19

	S2	9.5 mm 3/8"	x1
---	----	----------------	----

	S2	1:1
---	----	-----



20



	S3	12 mm 1/2"	x1
---	----	---------------	----

	x1
---	----

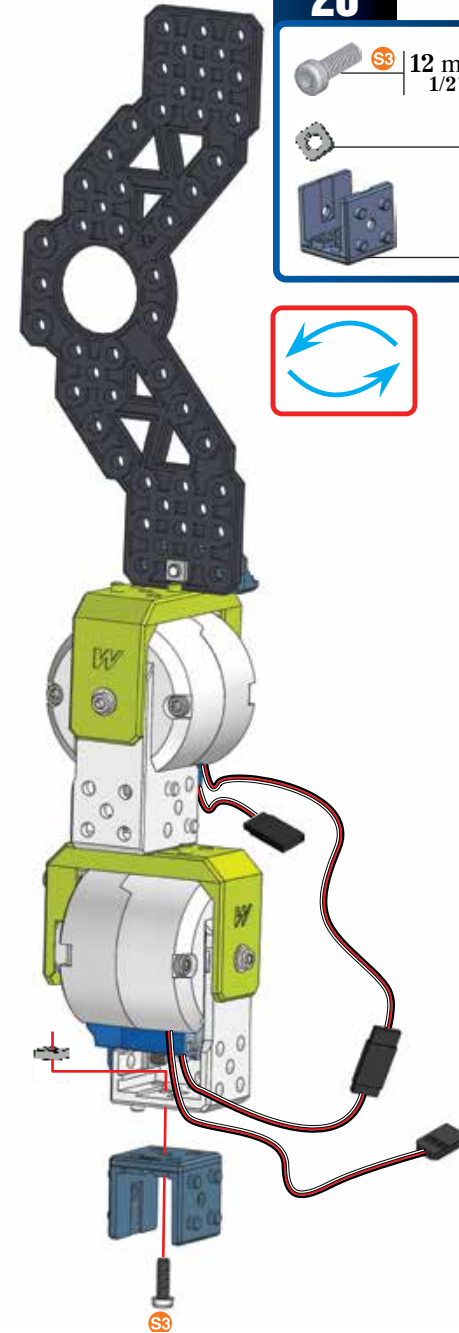
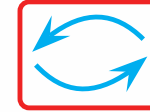
	x1
---	----



**21** ⑨+⑳+

	12 mm 1/2"	<b>x1</b>
		<b>x1</b>

	<b>S3</b>	<b>1:1</b>
---	-----------	------------

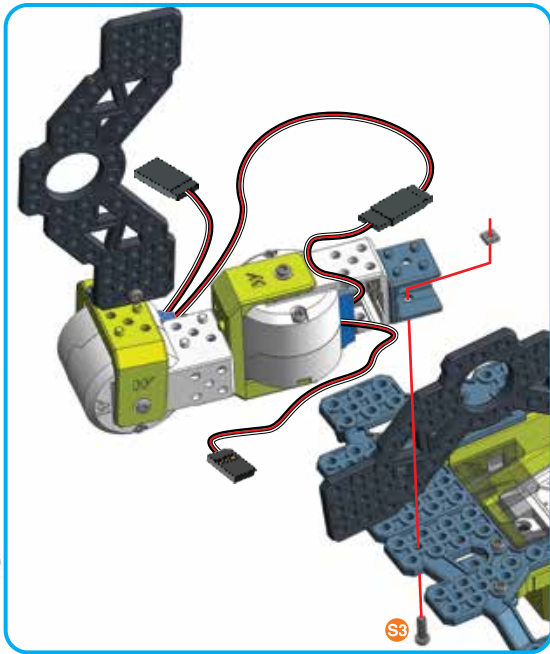
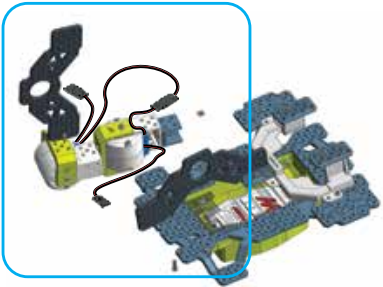

**22**

	12 mm 1/2"	<b>x1</b>
		<b>x1</b>

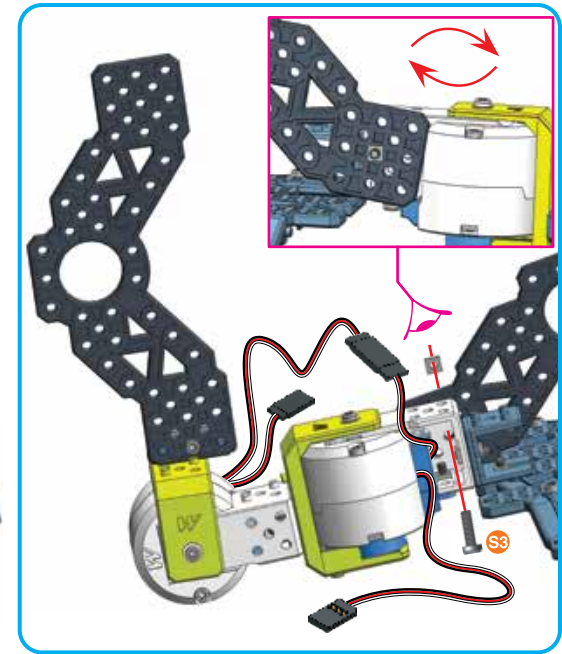
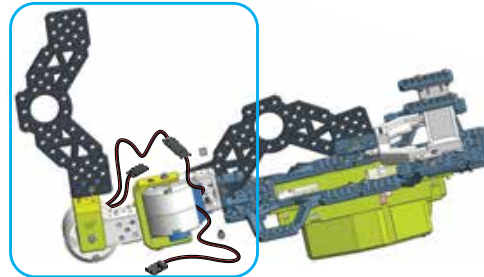



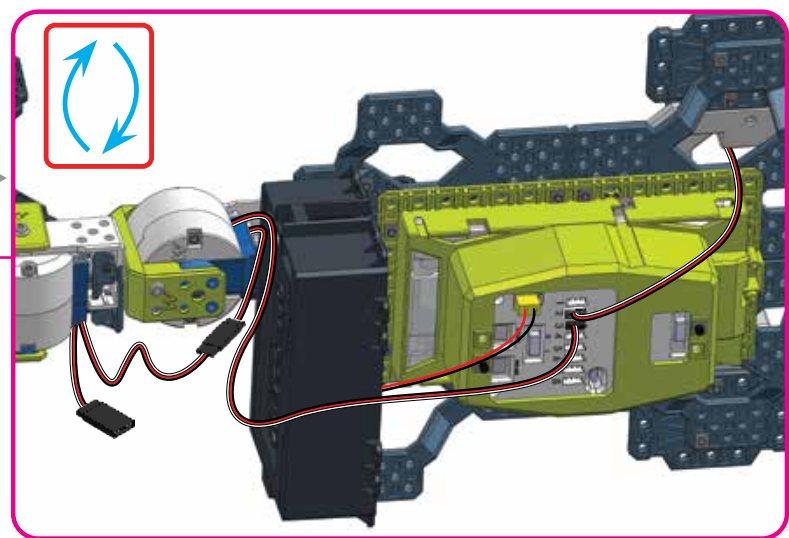
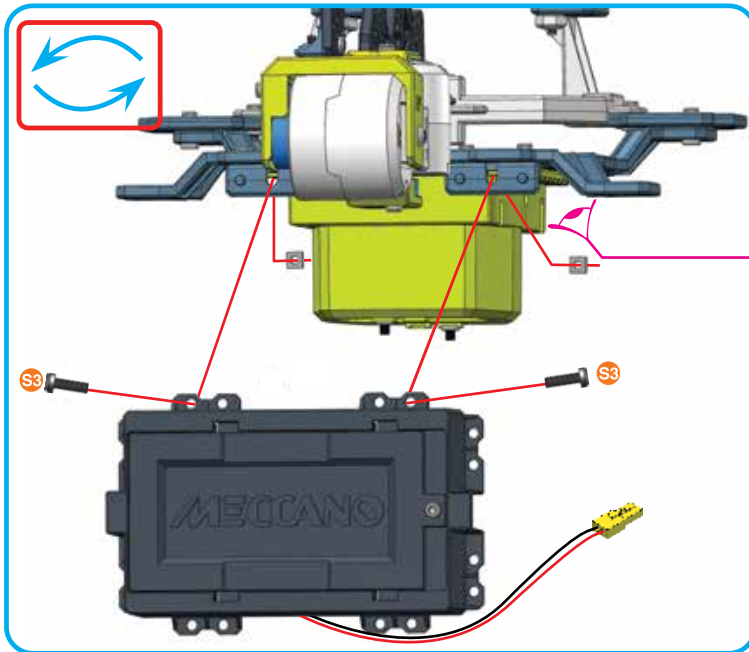
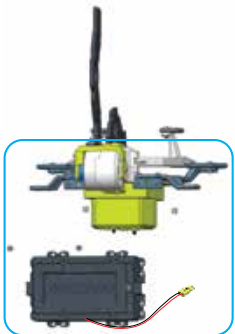

**23**

	12 mm 1/2"	<b>x2</b>
		<b>x2</b>
		<b>x1</b>

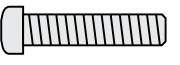

# 24

-  19 mm | 3/4" | **x4**
  -  | **x4**
  -  | **x2**
  -  | **x1**
  -  | **x2**
- |   |           |            |
|---|-----------|------------|
|  | <b>S4</b> | <b>1:1</b> |
|---|-----------|------------|

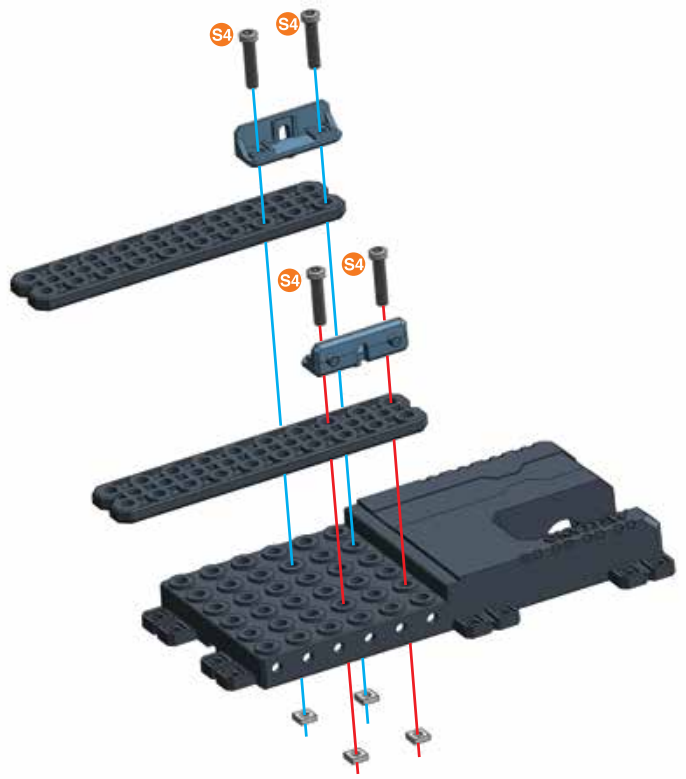

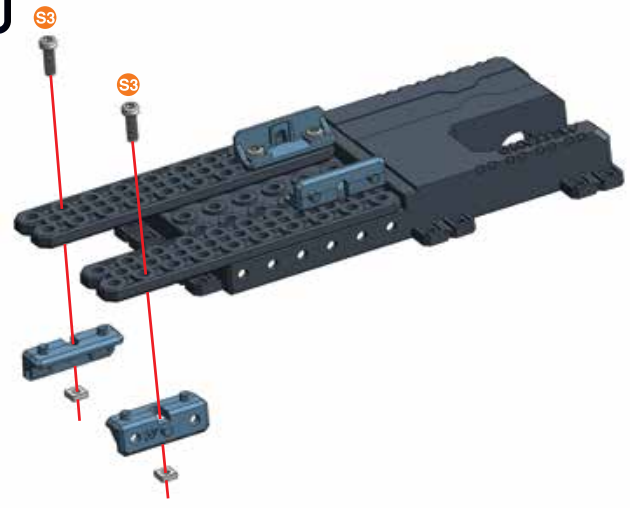

# 25

-  12 mm | 1/2" | **x2**
  -  | **x2**
  -  | **x2**
- |   |           |            |
|---|-----------|------------|
|  | <b>S3</b> | <b>1:1</b> |
|---|-----------|------------|



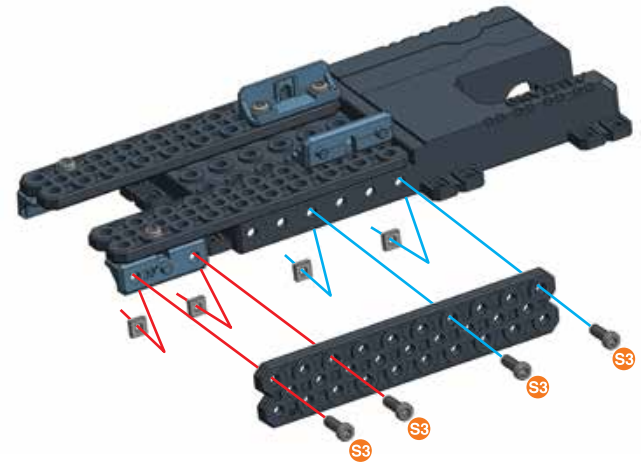

# 26

-  12 mm | 1/2" | **x4**
-  | **x4**
-  | **x1**





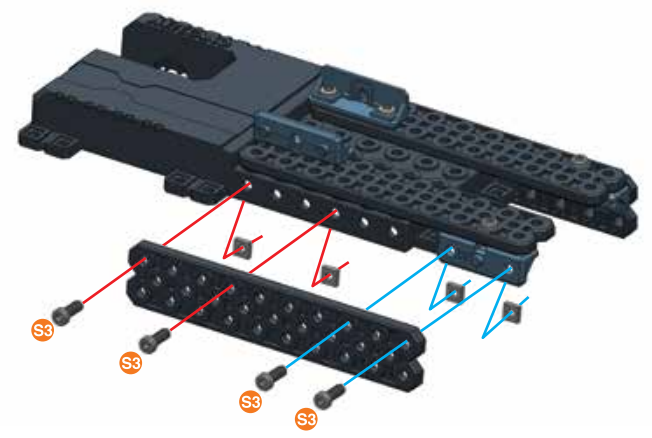

# 27

-  12 mm | 1/2" | **x4**
-  | **x4**
-  | **x1**



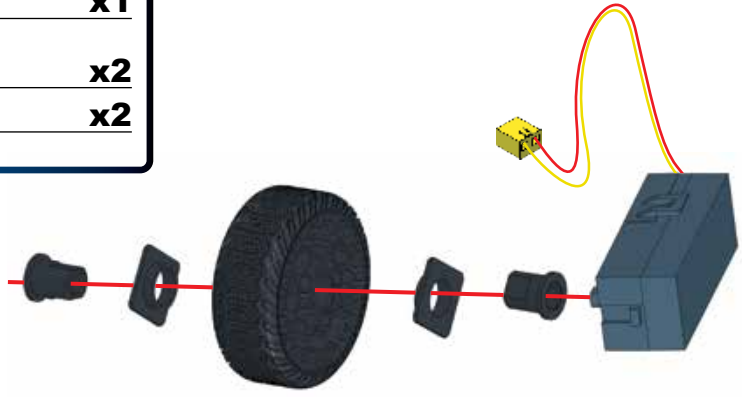
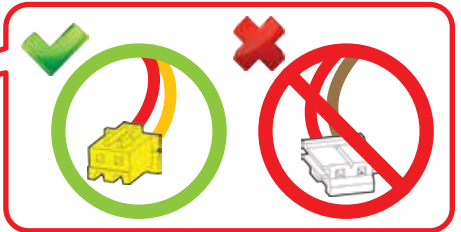

# 28

-  **x1**
-  **x1**
-  **x2**
-  **x2**





# 39

(27)+(28)+

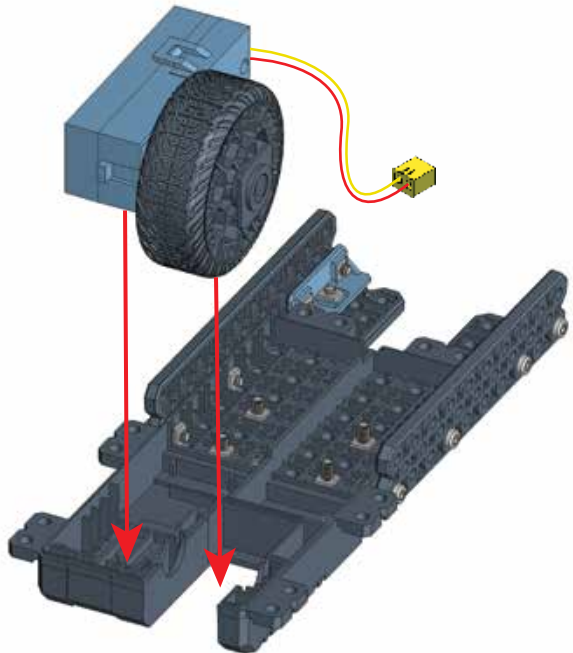
-  **x1**
-  **x1**





# 30

-  12 mm | 1/2" **x6**
-  **x6**
-  **x1**

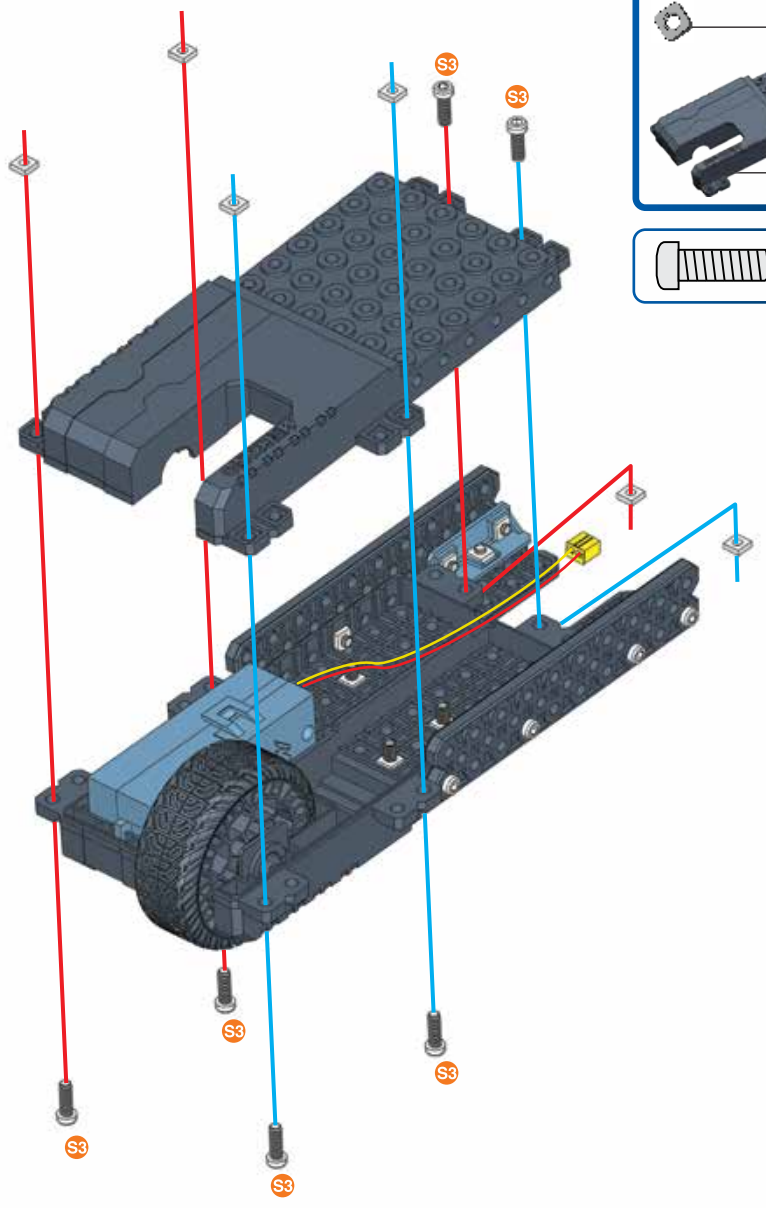
-  **1:1**



**31**

	12 mm 1/2"	<b>x4</b>
		<b>x4</b>
		<b>x1</b>

	<b>1:1</b>
---	------------

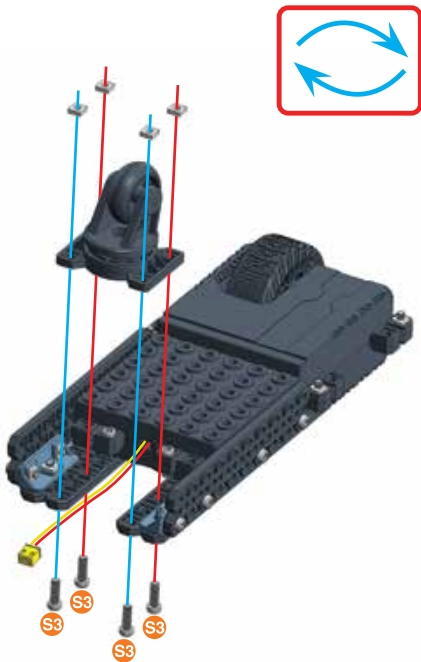

**32**

	12 mm 1/2"	<b>x7</b>
		<b>x7</b>
		<b>x3</b>
		<b>x1</b>

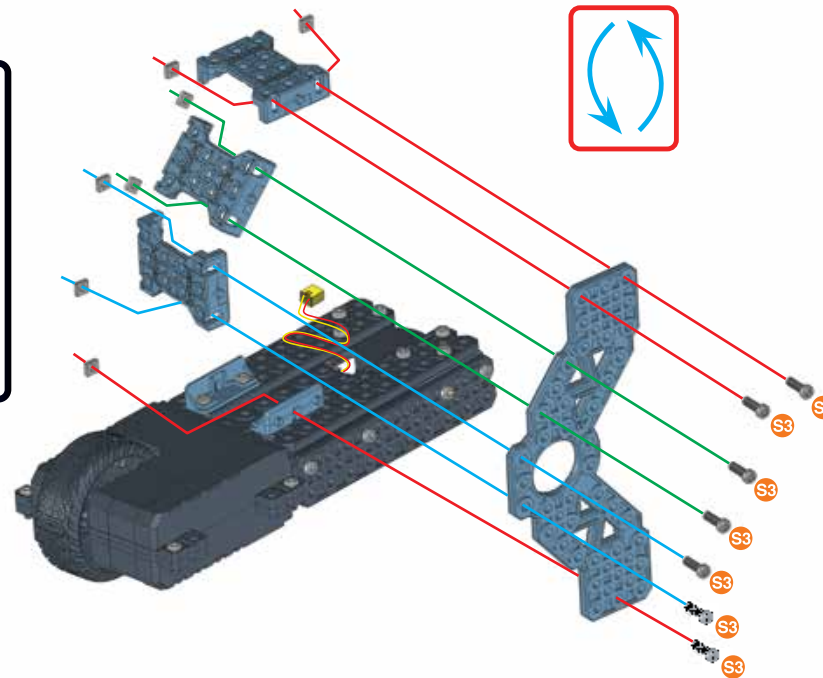

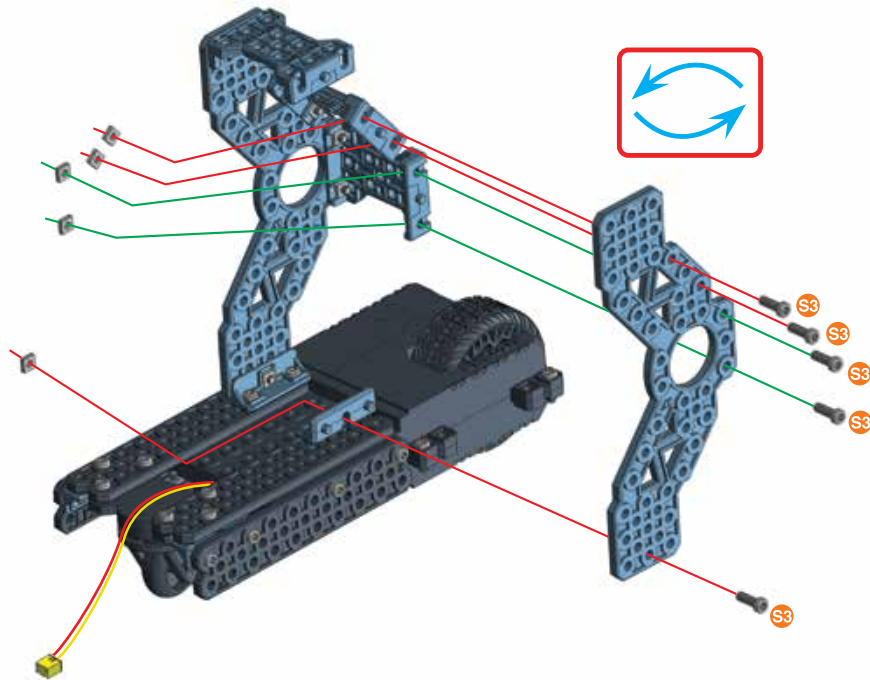

**33**

	12 mm 1/2"	<b>x5</b>
		<b>x5</b>
		<b>x1</b>





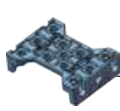

### 34

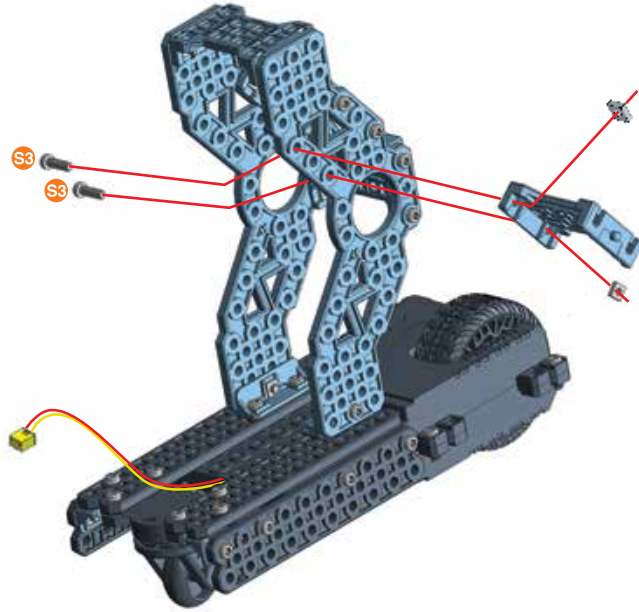
-  **S3** | 12 mm | **x2**
-  **x2**
-  **x1**

-  **S3** | **1:1**



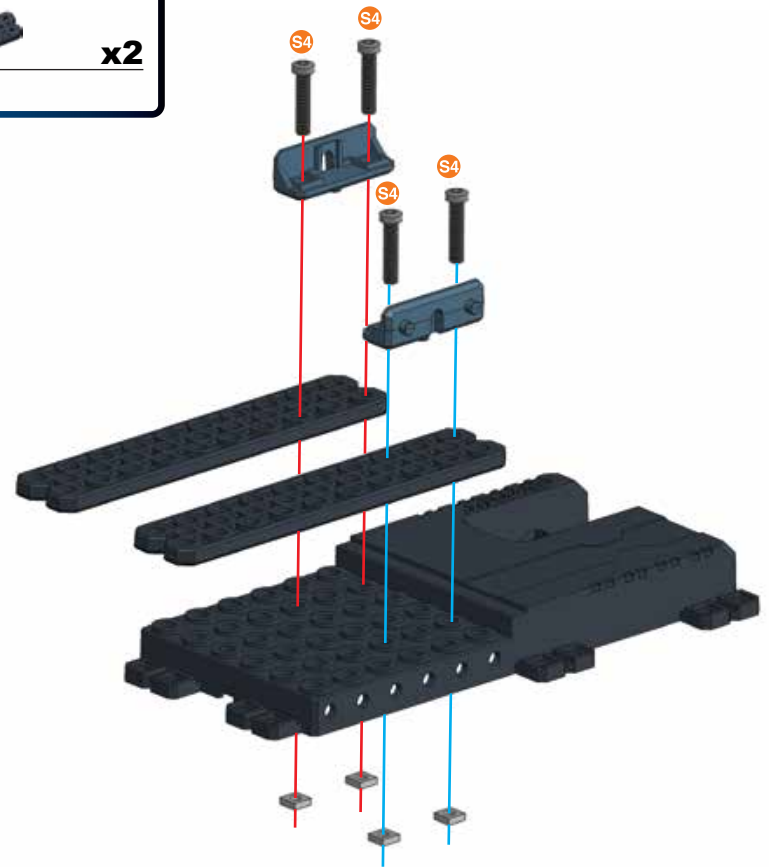

### 36

-  **S4** | 19 mm | **x4**
-  **x4**
-  **x2**
-  **x1**
-  **x2**

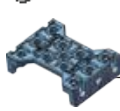

### 35

-  **S4** | 19 mm | **x2**
-  **x2**
-  **x1**

-  **S4** | **1:1**

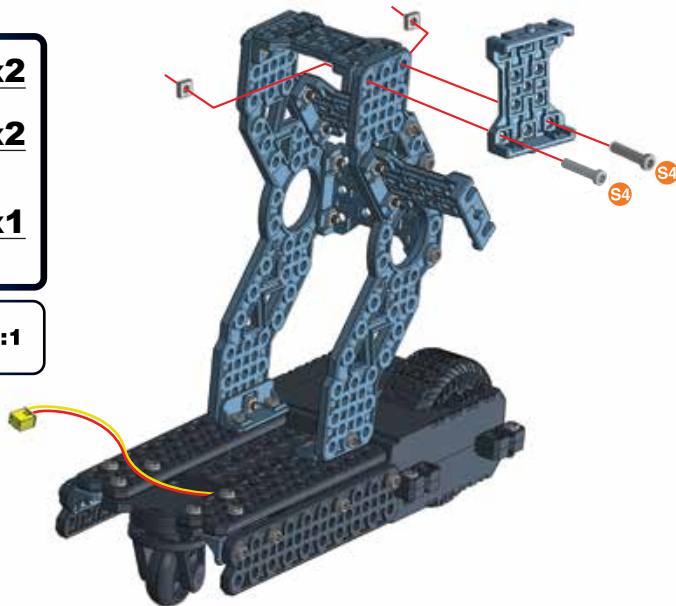

### 37

- 12 mm | **x2**
- | **x2**
- | **x2**

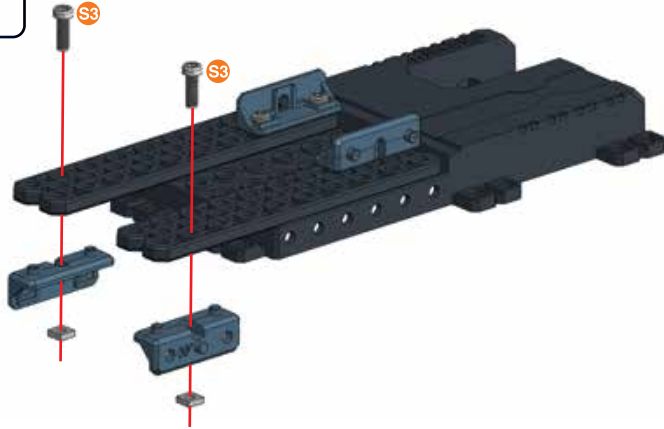

### 38

- 12 mm | **x4**
- | **x4**
- | **x1**

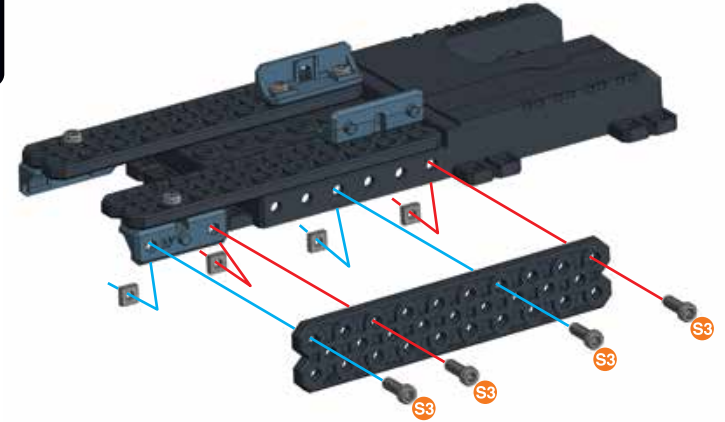

### 39

- 12 mm | **x4**
- | **x4**
- | **x1**

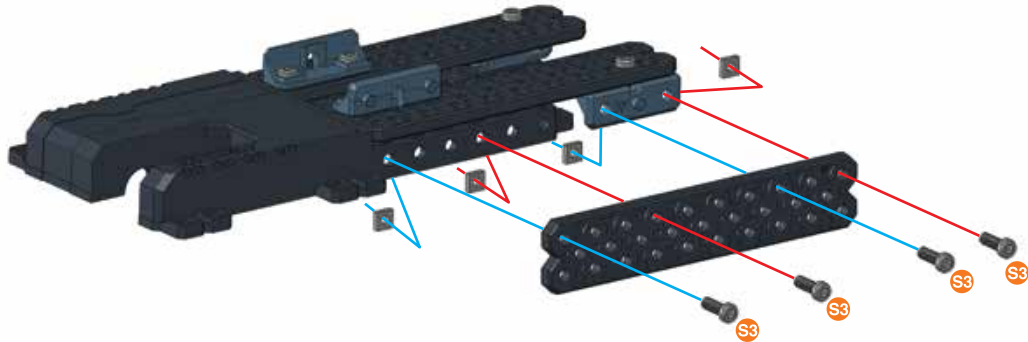
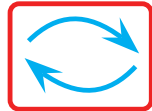

### 40

- | **x1**
- | **x1**
- | **x2**
- | **x2**

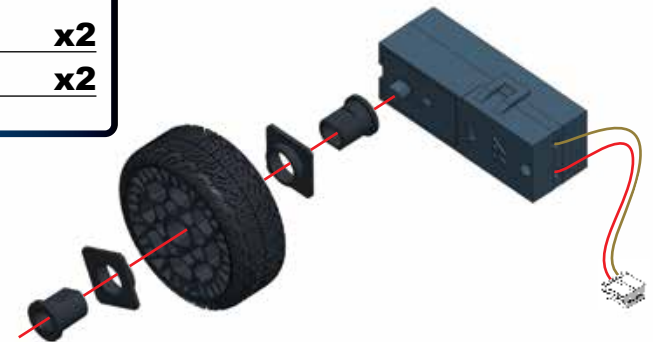
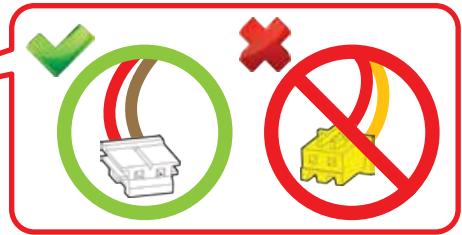



41

(39)+(40)+

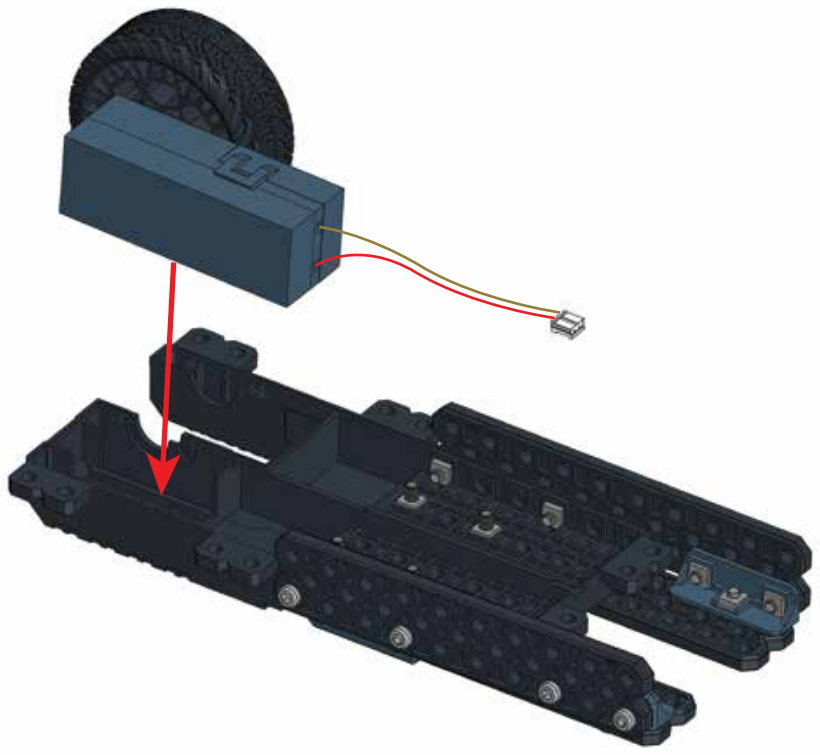
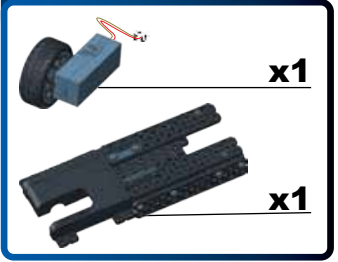

42

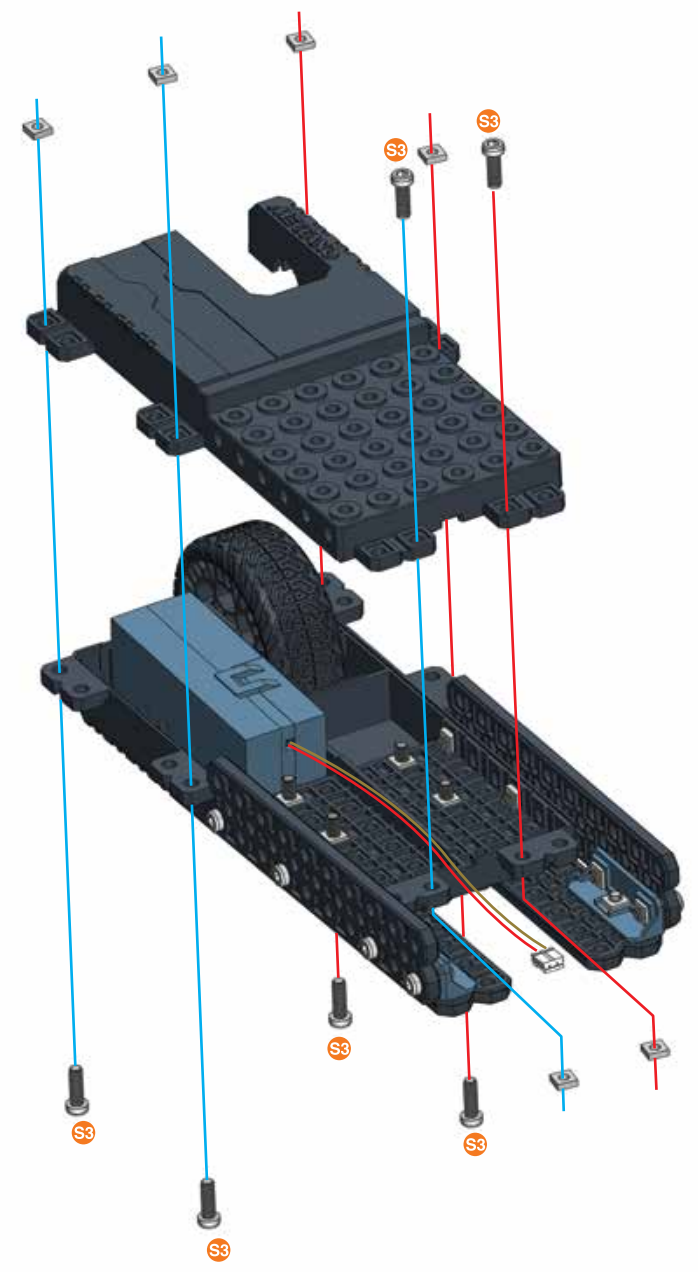
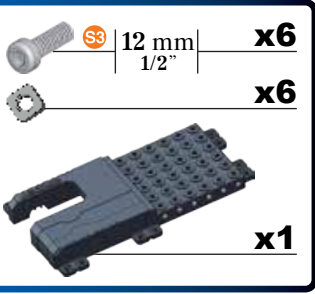



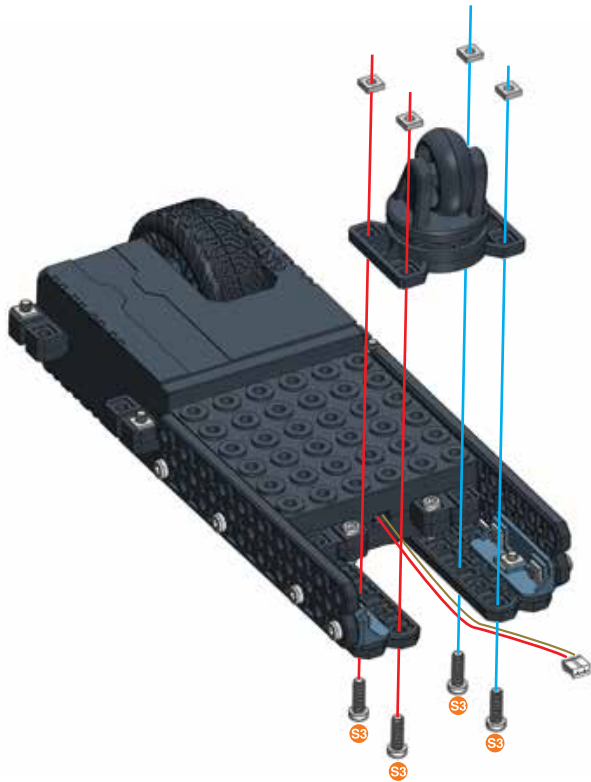

# 43

-  12 mm | 1/2" | **x4**
-  | **x4**
-  | **x1**

-  | **1:1**



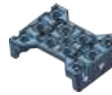

# 44

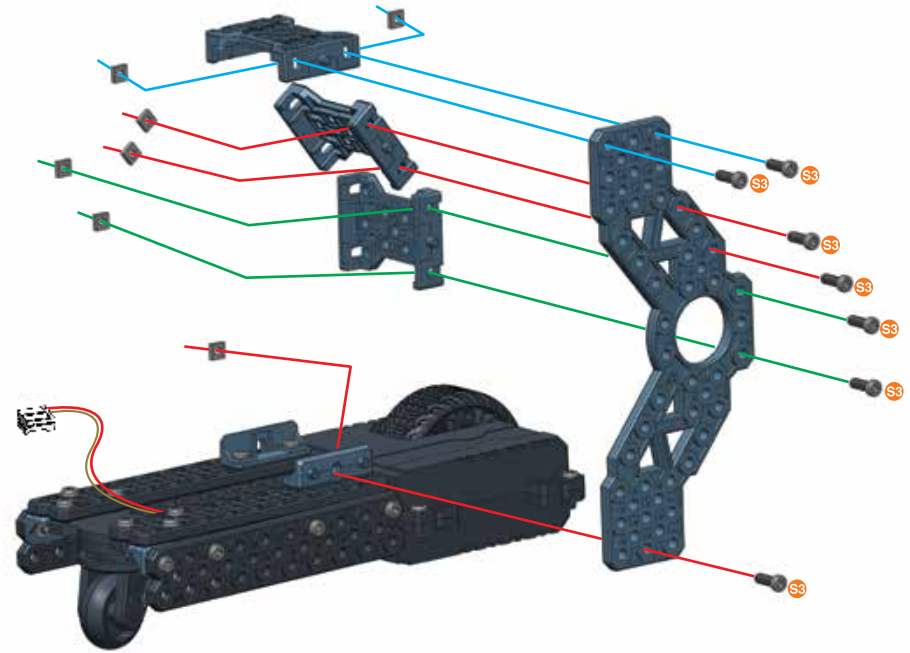
-  12 mm | 1/2" | **x7**
-  | **x7**
-  | **x3**
-  | **x1**



# 45

-  12 mm | 1/2" | **x5**
-  | **x5**
-  | **x1**

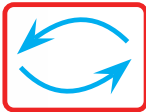
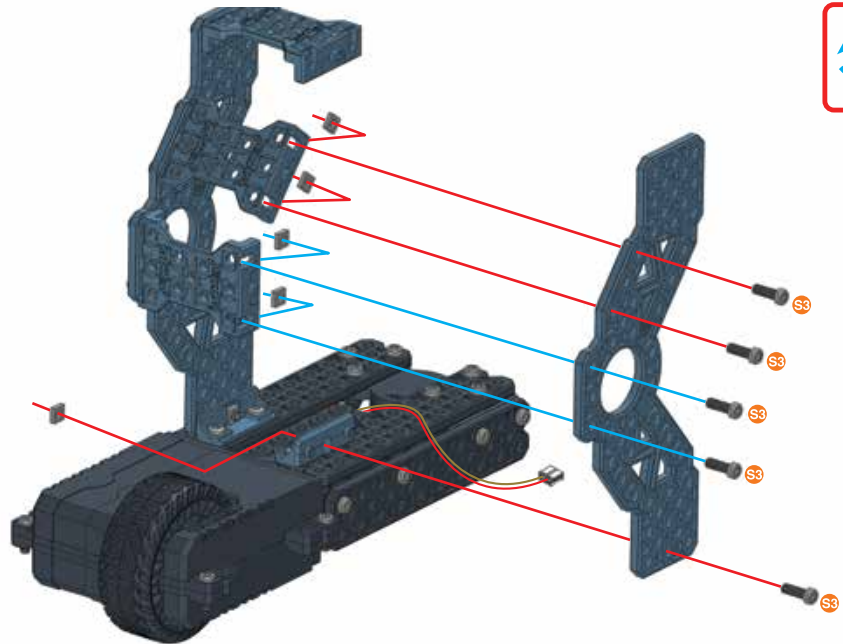

**46**

	12 mm 1/2"	<b>x2</b>
		<b>x2</b>
		<b>x1</b>

	<b>S3</b>	<b>1:1</b>
---	-----------	------------

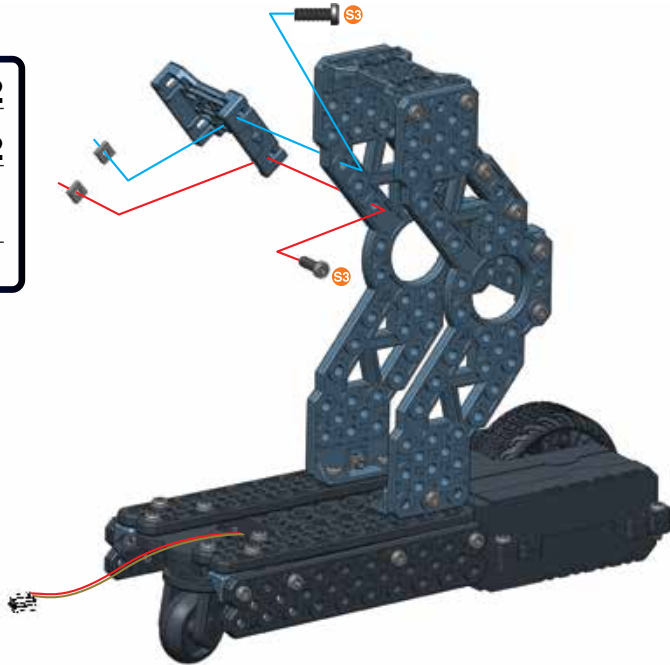



**47**

	19 mm 3/4"	<b>x2</b>
		<b>x2</b>
		<b>x1</b>

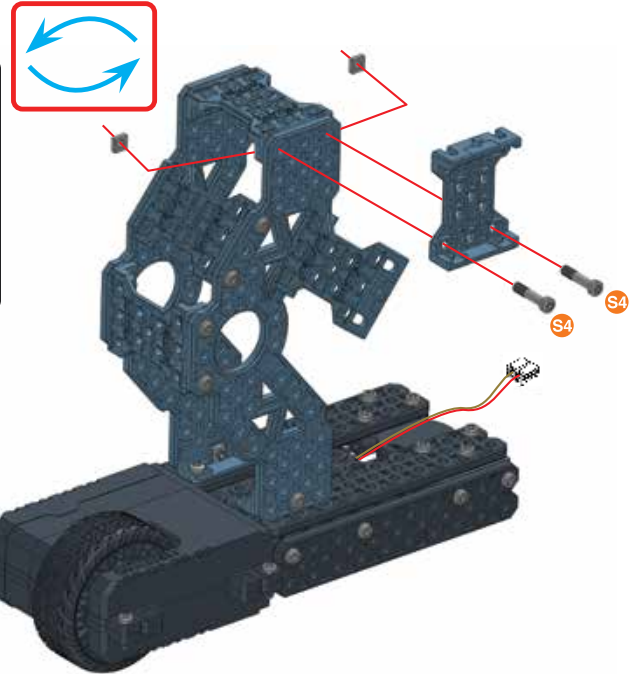
	<b>S4</b>	<b>1:1</b>
---	-----------	------------



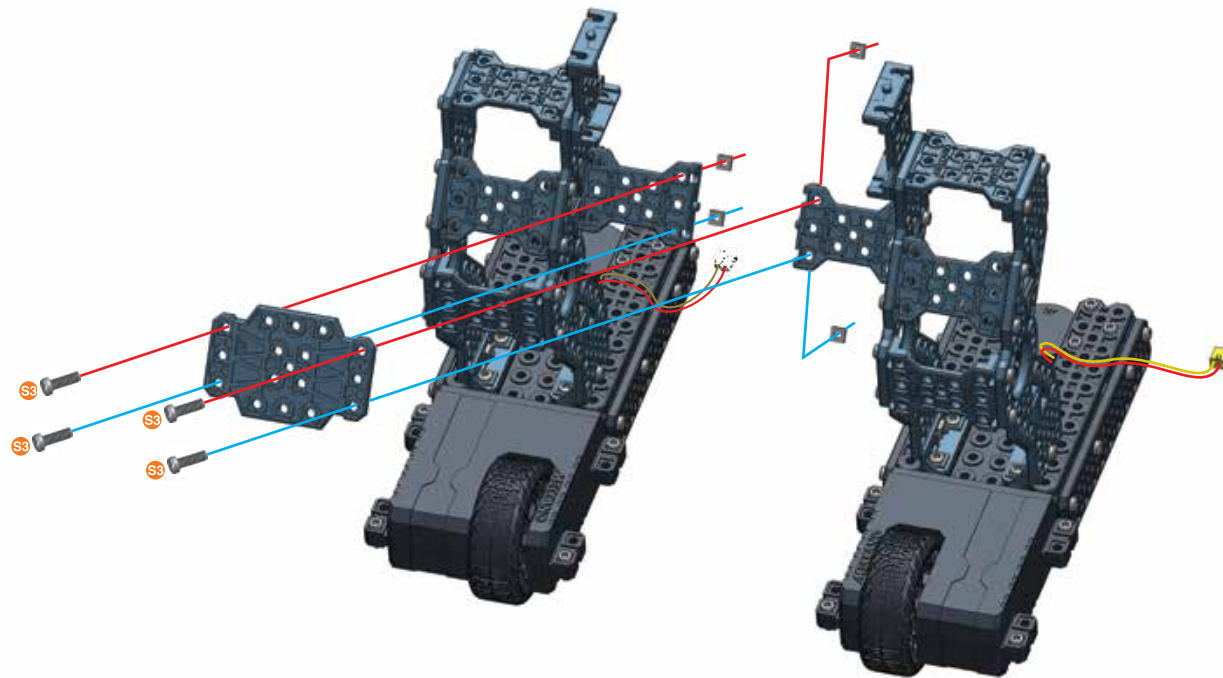

**48** (35)+(47)+

	12 mm 1/2"	<b>x4</b>
		<b>x4</b>
		<b>x1</b>



49

(23)+(48)+

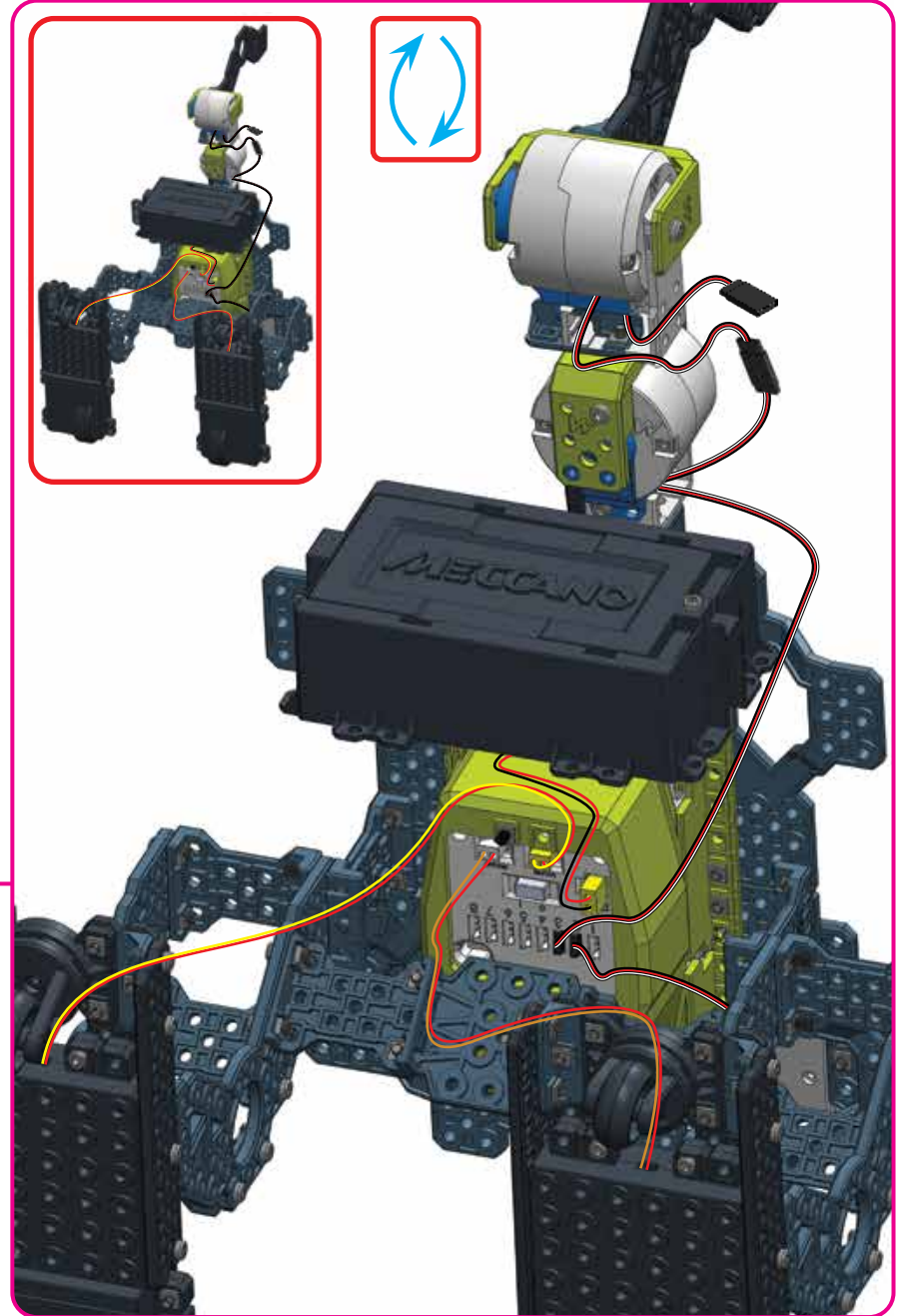
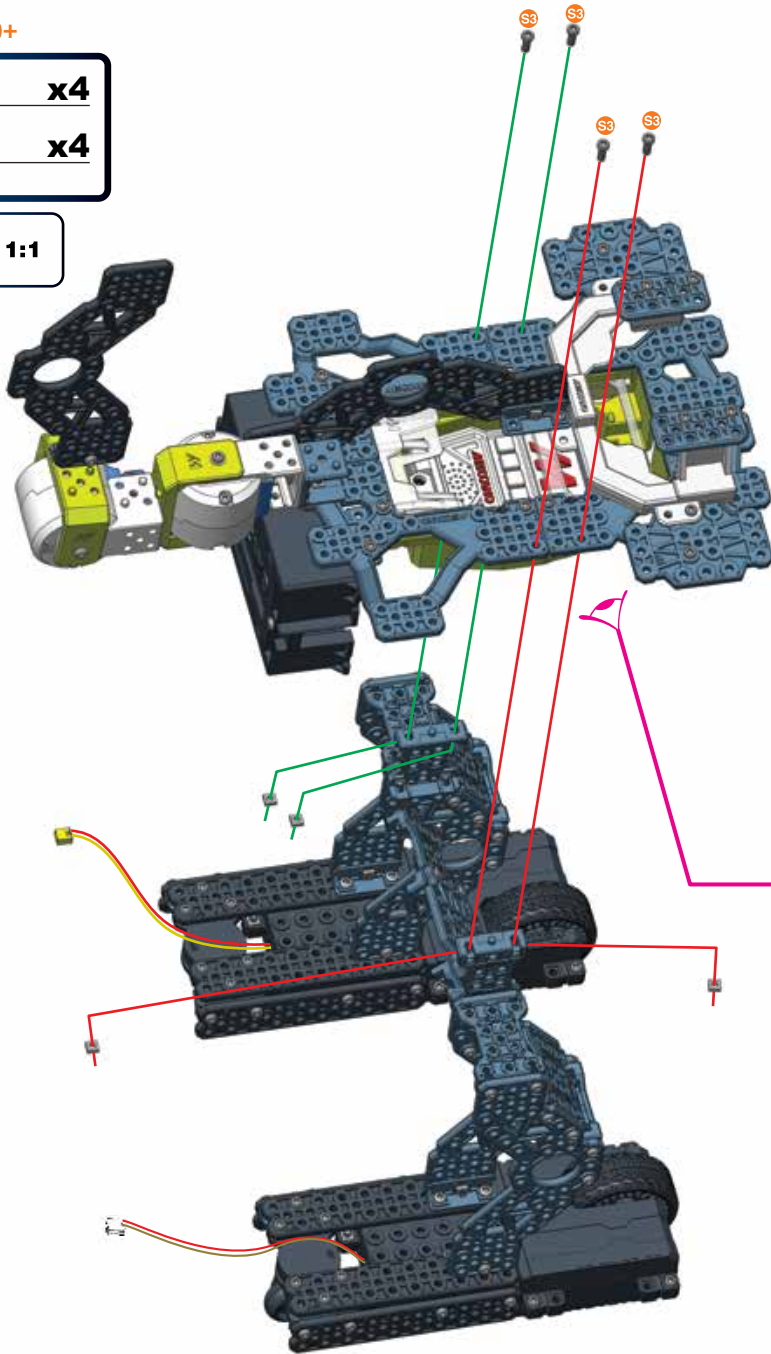

- |   |               |    |
|---|---------------|----|
|  | 12 mm<br>1/2" | x4 |
|  |               | x4 |

- |   |     |
|---|-----|
|  | 1:1 |
|---|-----|

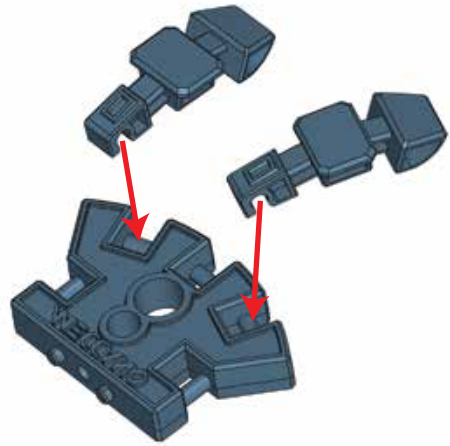
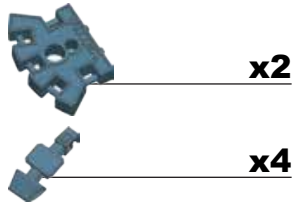
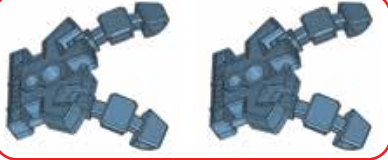
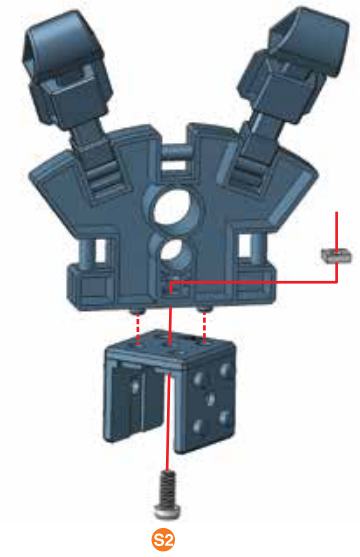
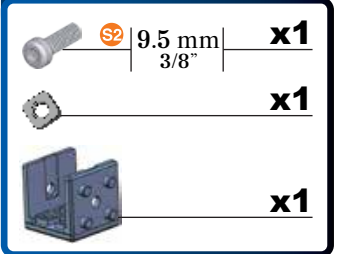
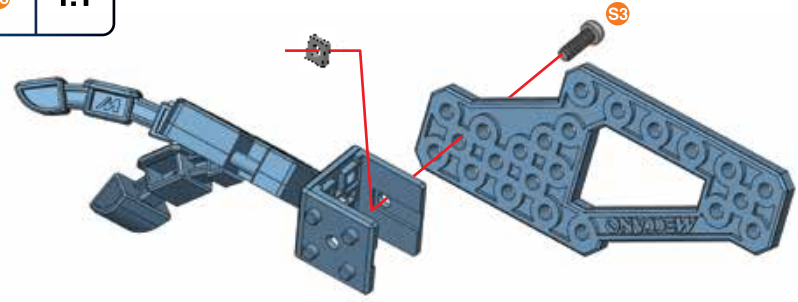
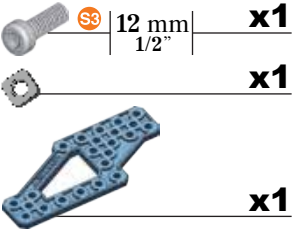
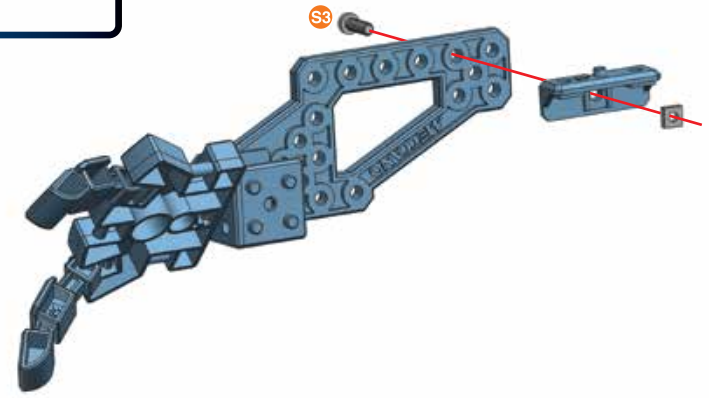
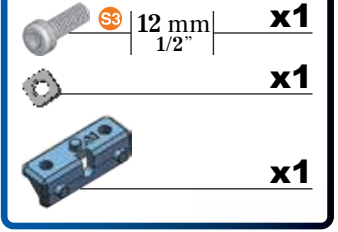

**50****x2****51****50+****52****53**

# 54

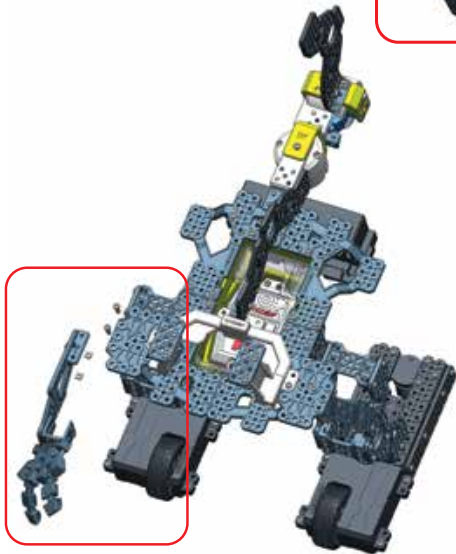
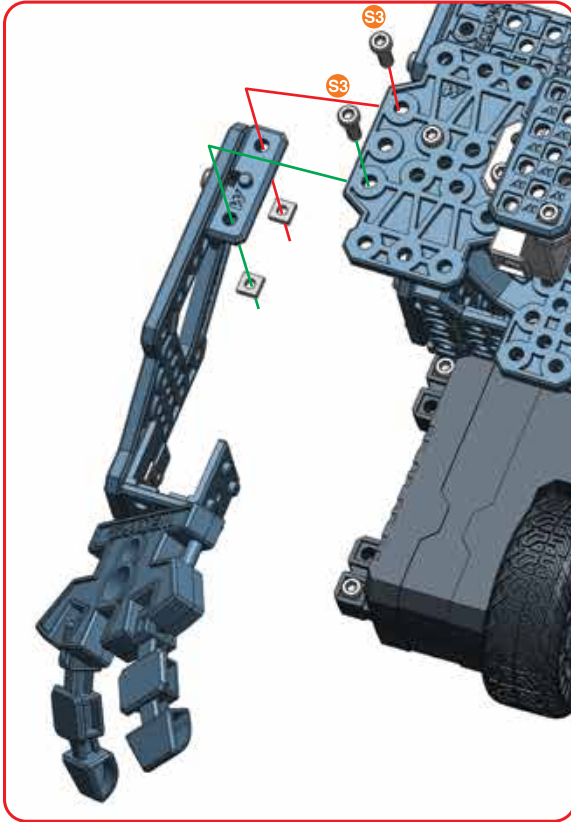

-  | 12 mm | **x2**  
1/2"
-  | **x2**

-  | **1:1**



# 55



(50+)

-  | 9.5 mm | **x1**  
3/8"
-  | **x1**
-  | **x1**

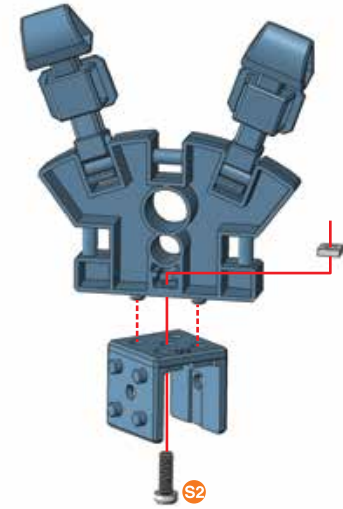
-  | **1:1**



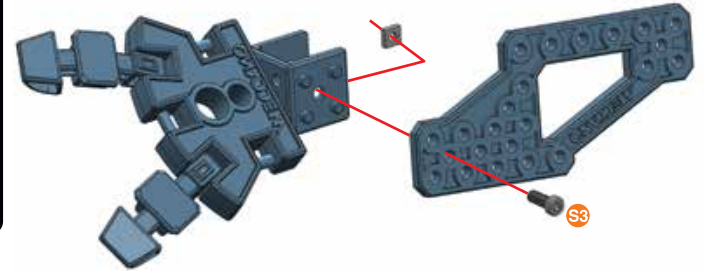

# 56

-  | 12 mm | **x1**  
1/2"
-  | **x1**
-  | **x1**



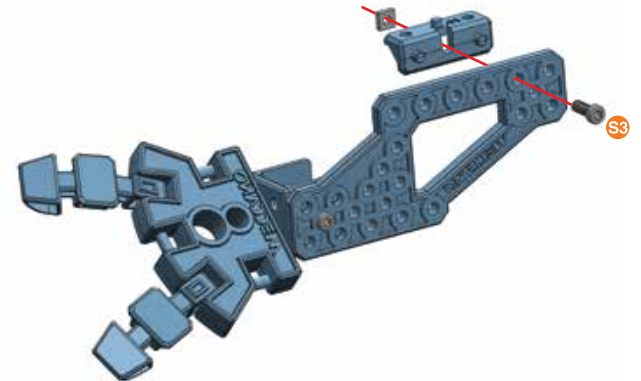

# 57

-  | 12 mm | **x1**  
1/2"
-  | **x1**
-  | **x1**



58



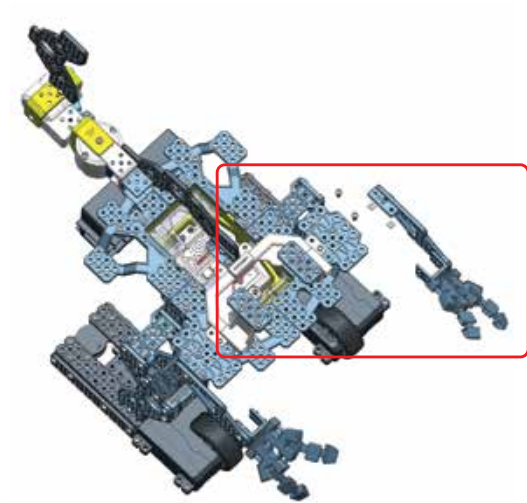
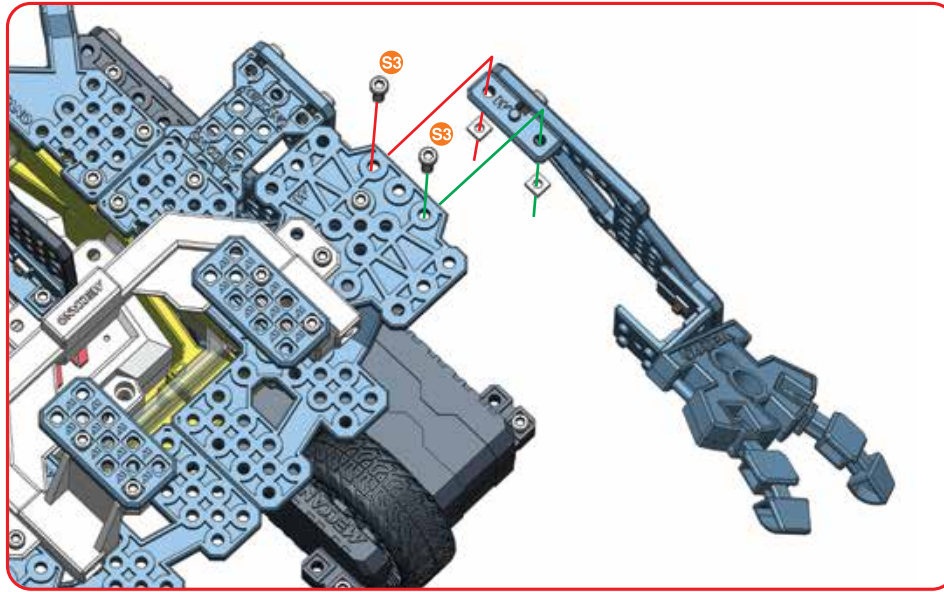

54+57+

-  12 mm | 1/2" | **x2**
-  | **x2**

-  | **1:1**





59

-  12 mm | 1/2" | **x2**
-  | **x1**
-  | **x1**
-  | **x1**

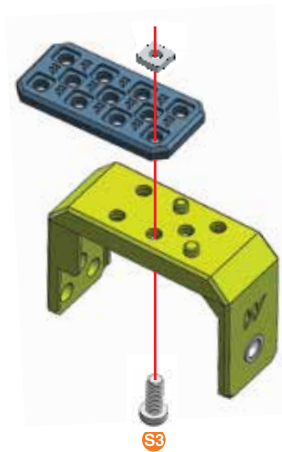
-  | **1:1**

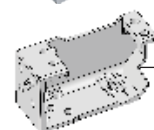
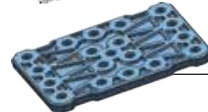

60

-  19 mm | 3/4" | **x2**
-  | **x2**
-  | **x1**
-  | **x1**
-  | **x1**

-  | **1:1**

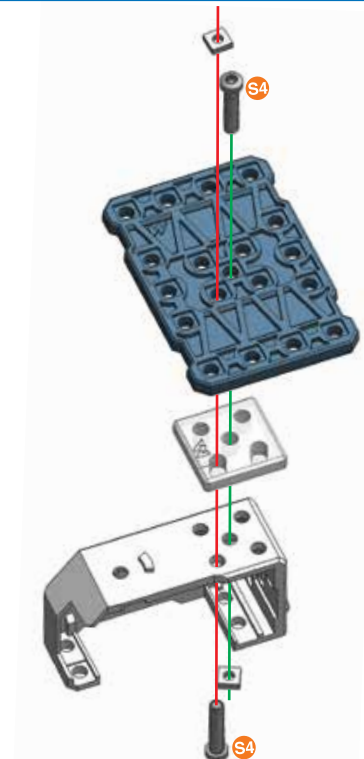

**61**

	<b>x1</b>
---	-----------

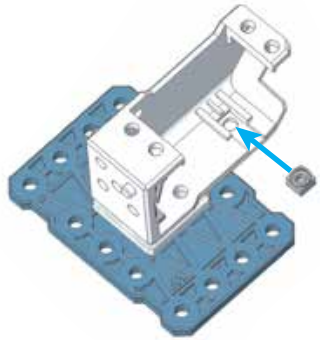
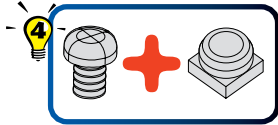



**62**

	12 mm 1/2"	<b>x1</b>
		<b>x1</b>
		<b>x1</b>

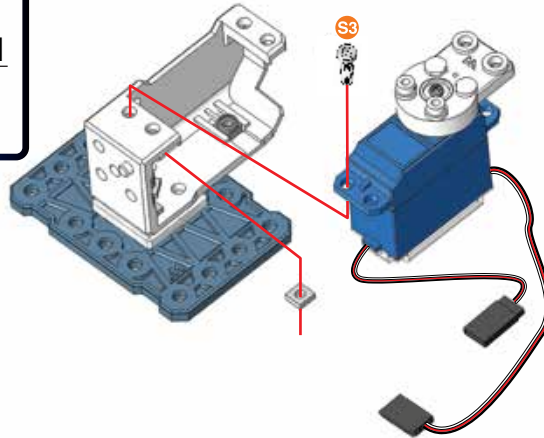
	<b>S3</b>	<b>1:1</b>
---	-----------	------------



**63**

	19 mm 3/4"	<b>x1</b>
		<b>x1</b>
		<b>x1</b>

	<b>S4</b>	<b>1:1</b>
---	-----------	------------

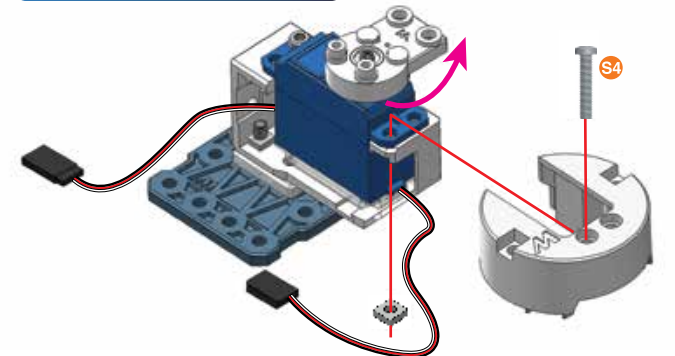



**64**

	38.1mm 1 1/2"	<b>x2</b>
		<b>x2</b>
		<b>x1</b>

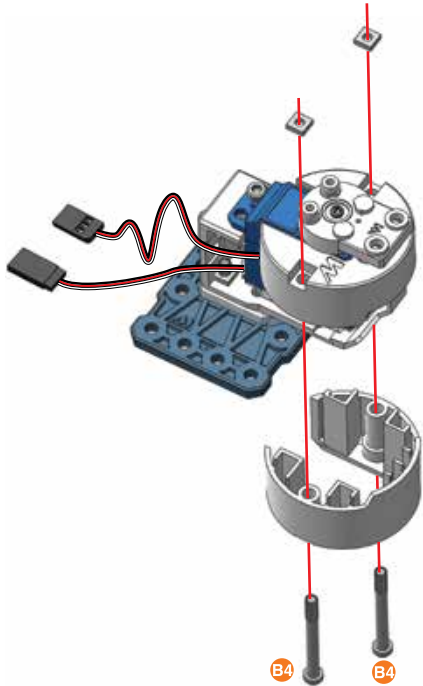
	<b>B4</b>	<b>1:1</b>
---	-----------	------------



**65** (59)+(64)+

	9.5 mm 3/8"	<b>x1</b>
	<b>S2</b>	<b>1:1</b>

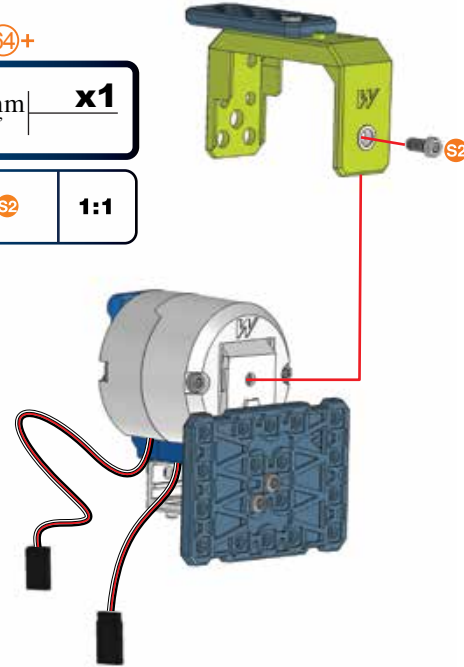
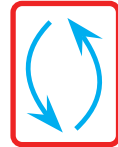

**66**

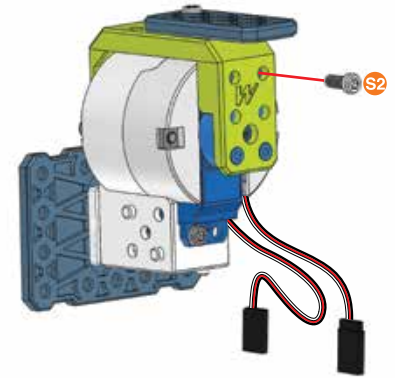
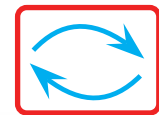

	9.5 mm 3/8"	<b>x1</b>
---	----------------	-----------





67



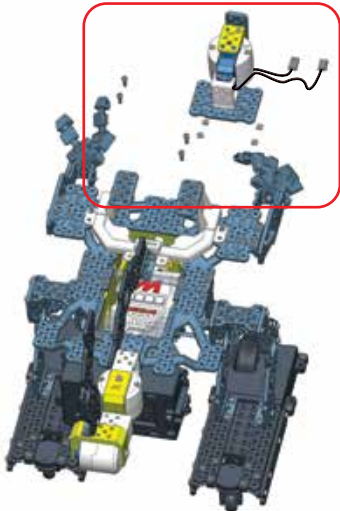
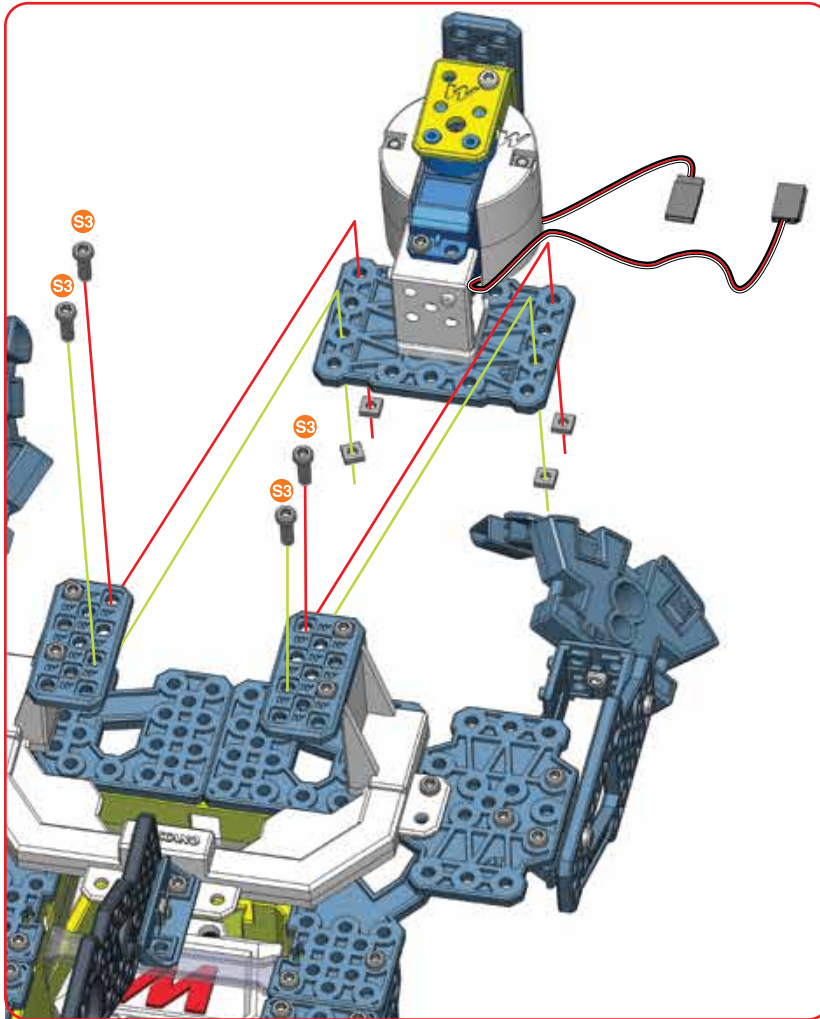

(58) + (66) +

	S3   12 mm	<b>x4</b>
		<b>x4</b>

	S3	<b>1:1</b>
---	----	------------



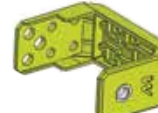
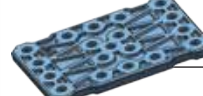

68

	S4   19 mm	<b>x5</b>
	3/4"	<b>x5</b>
		<b>x1</b>
		<b>x2</b>
		<b>x1</b>
		<b>x1</b>

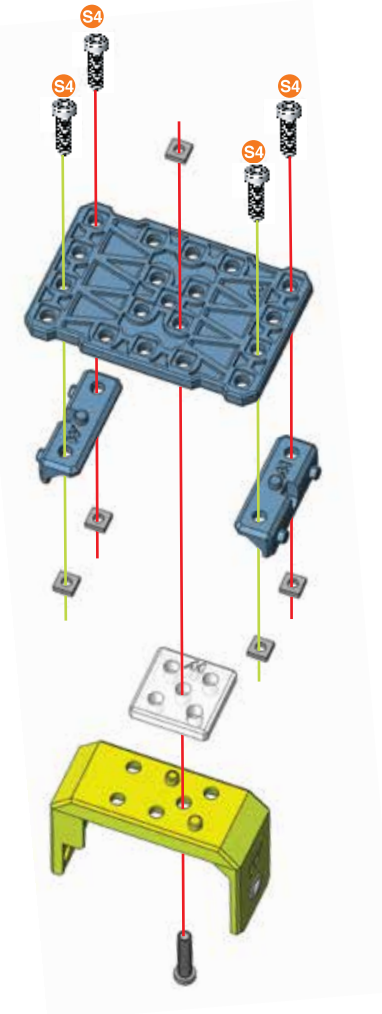
	S4	<b>1:1</b>
--	----	------------



**69** (14)+(68)+

	S2   9.5 mm   3/8"	<b>x1</b>
	S2	<b>1:1</b>

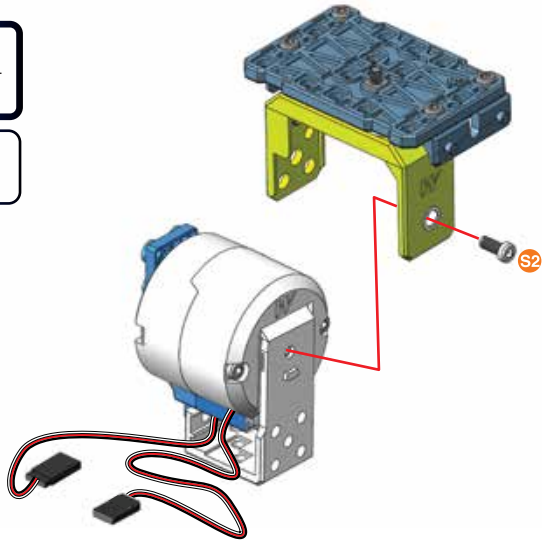

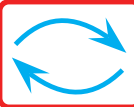

**70**

	S2   9.5 mm   3/8"	<b>x1</b>
---	--------------------	-----------

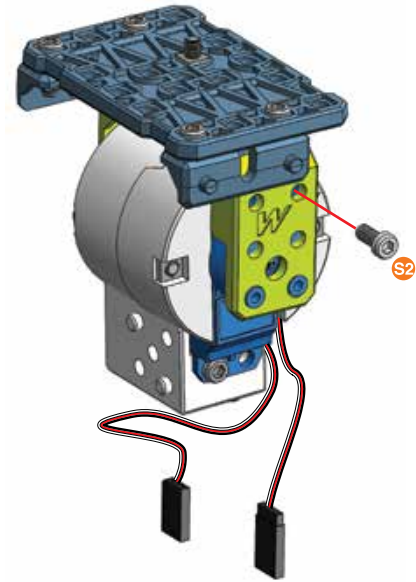



**71** (67)+(70)+

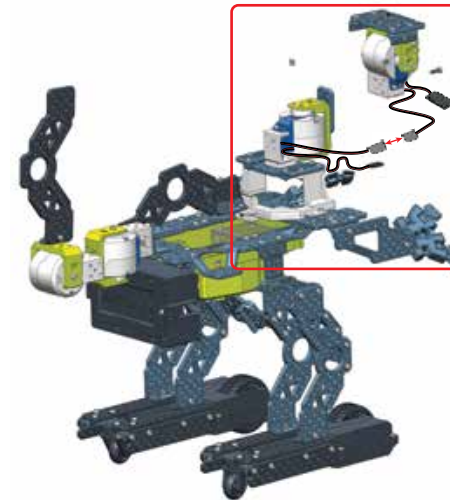
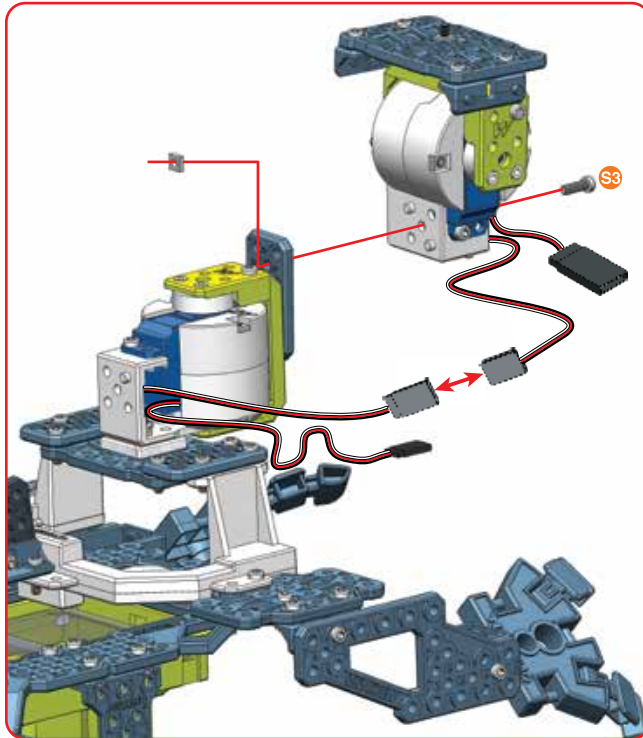

	S3   12 mm   1/2"	<b>x1</b>
		<b>x1</b>
	S3	<b>1:1</b>

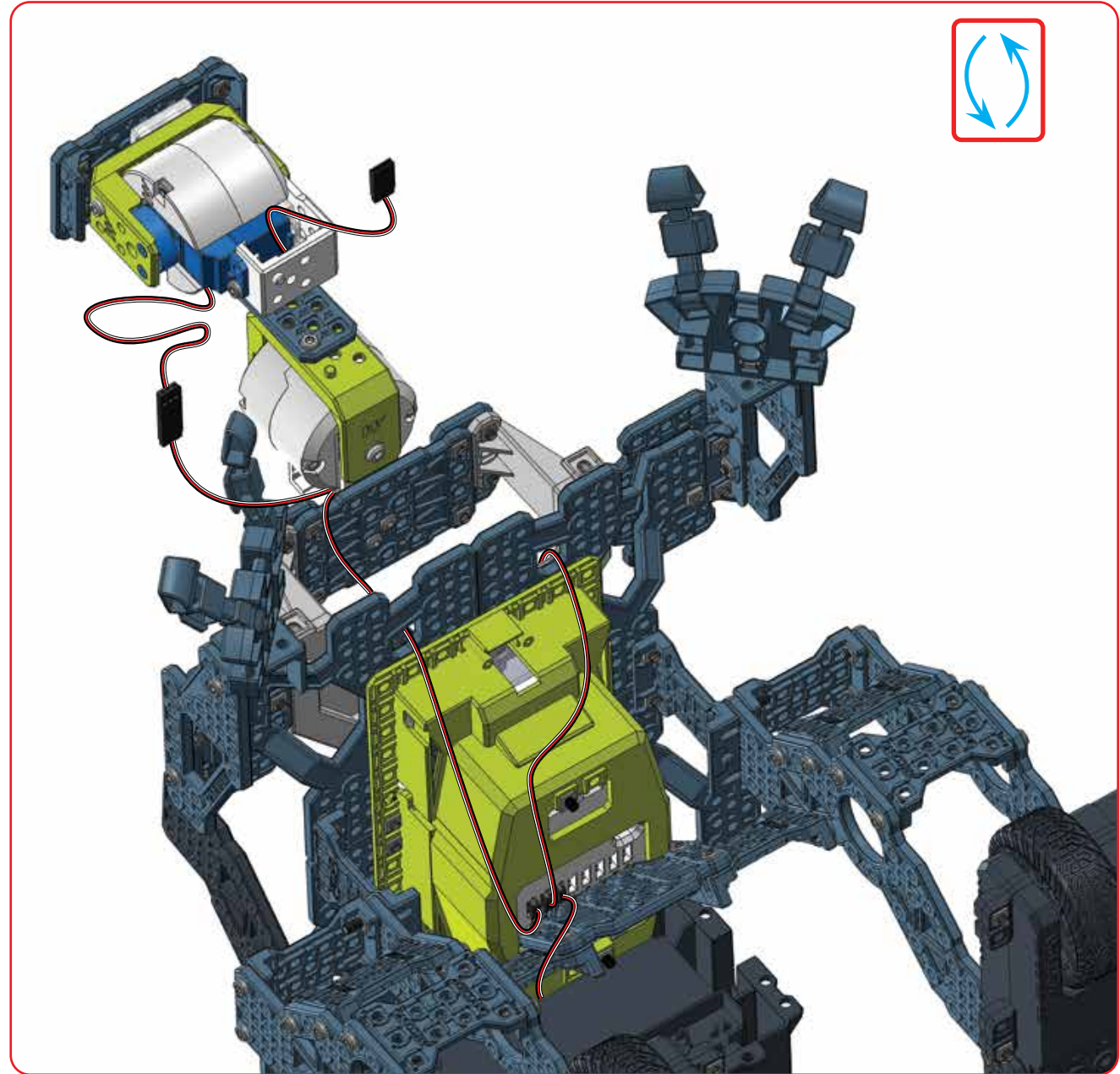
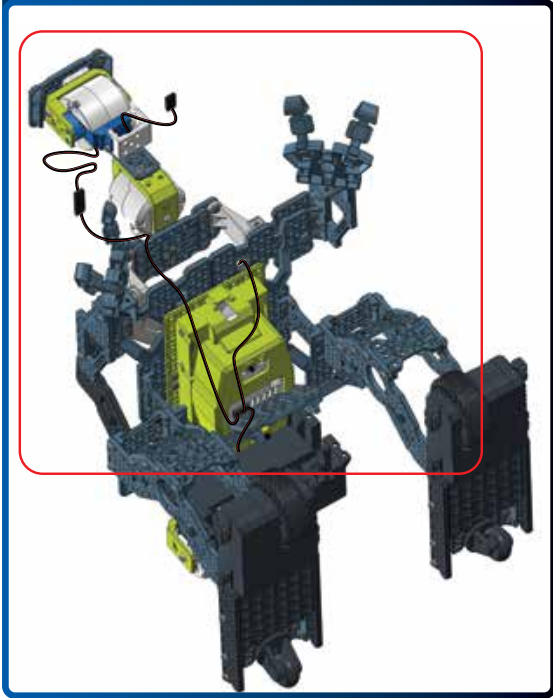

72





# 73

-  | 12 mm | 1/2" | **x1**
-  | **x1**
-  | **x1**

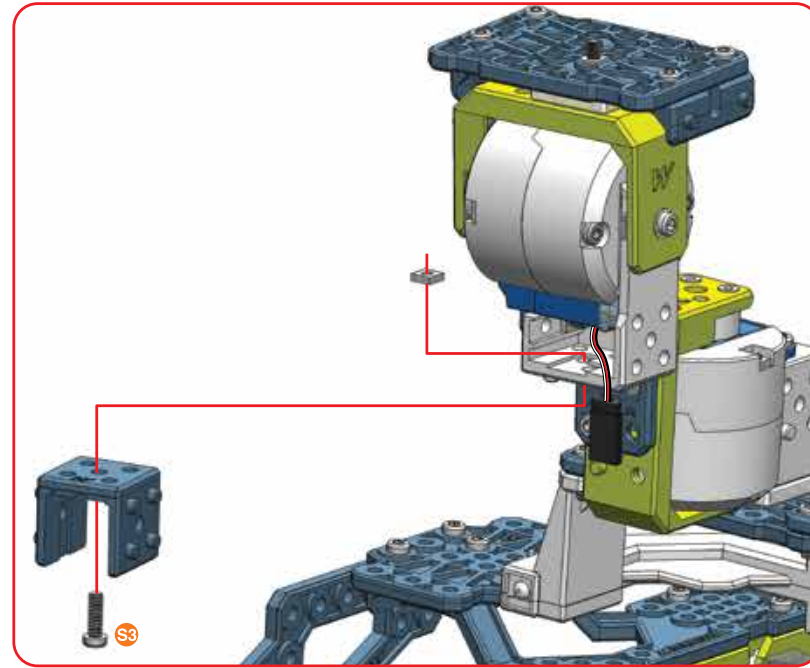
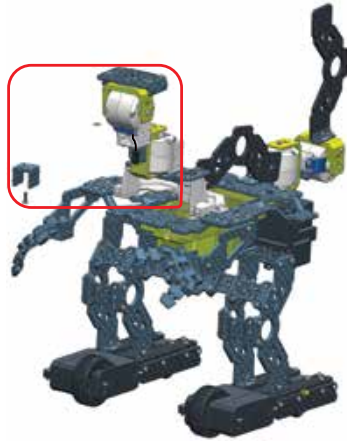
-  | **x1**



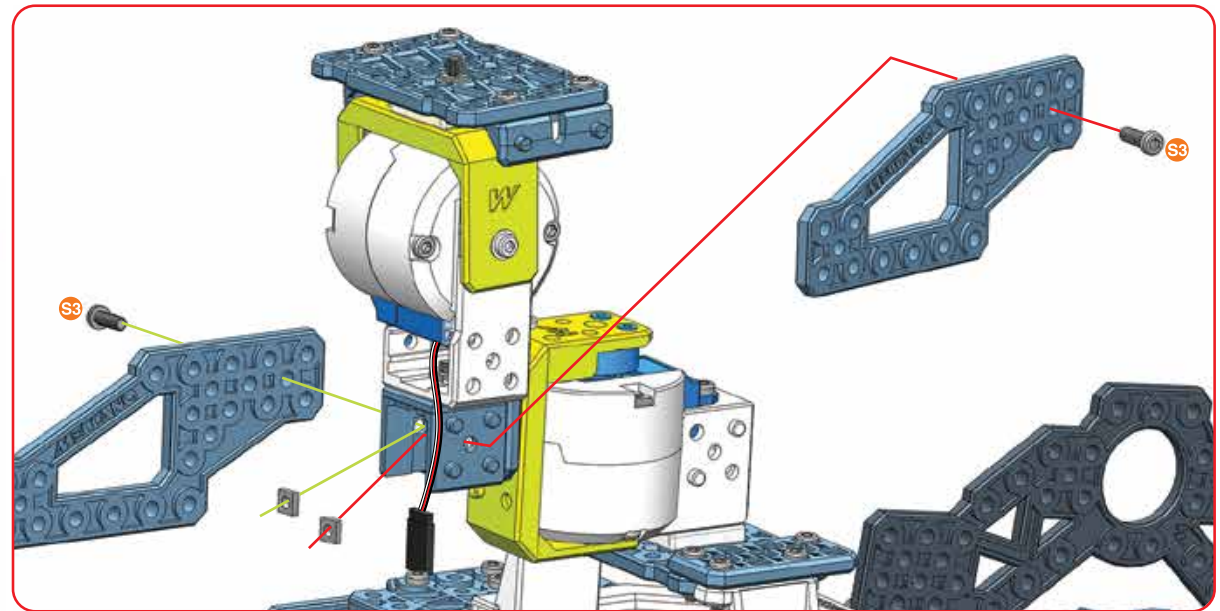

# 74

-  | 12 mm | 1/2" | **x2**
-  | **x2**
-  | **x2**





# 75

-  **x2**
-  **x2**
-  **x2**

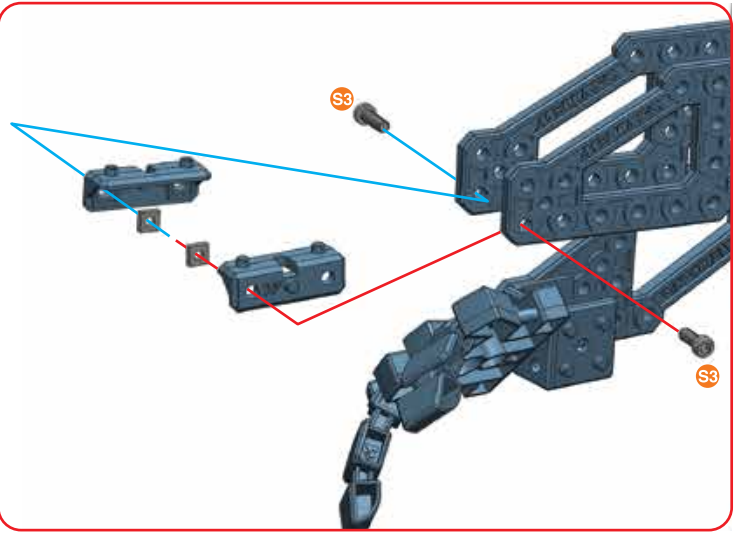
-  **1:1**



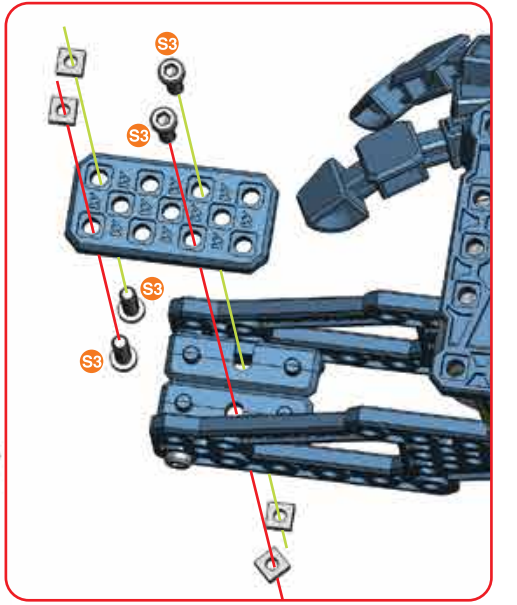

# 76

-  **x4**
-  **x4**
-  **x1**



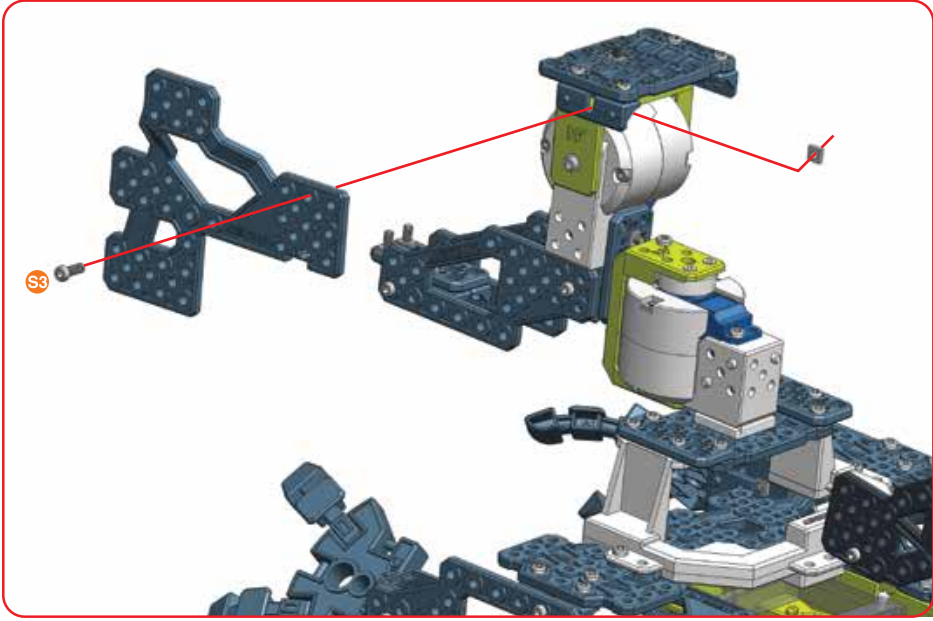

# 77

-  **x1**
-  **x1**
-  **x1**





# 78

-  **S3** | 12 mm | **x1**
-  **x1**
-  **x1**

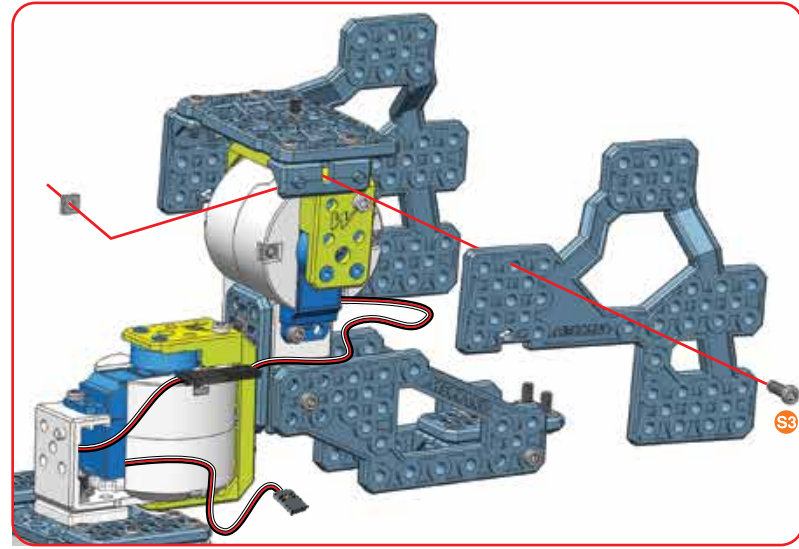
-  **S3** | **1:1**



# 79

-  **S4** | 19 mm | **x2**
-  **x2**
-  **x1**

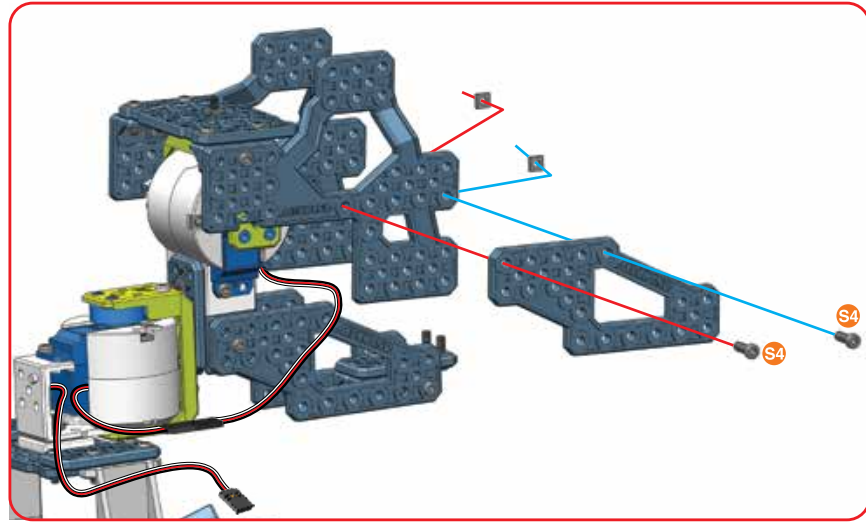

80

- x2**
- x2**
- x1**

- 1:1**

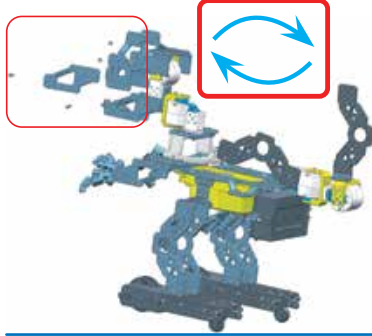
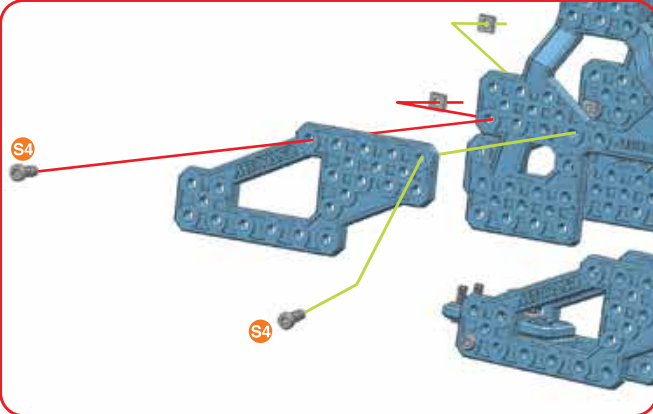

81

- x4**
- x4**
- x2**
- x2**

- 1:1**

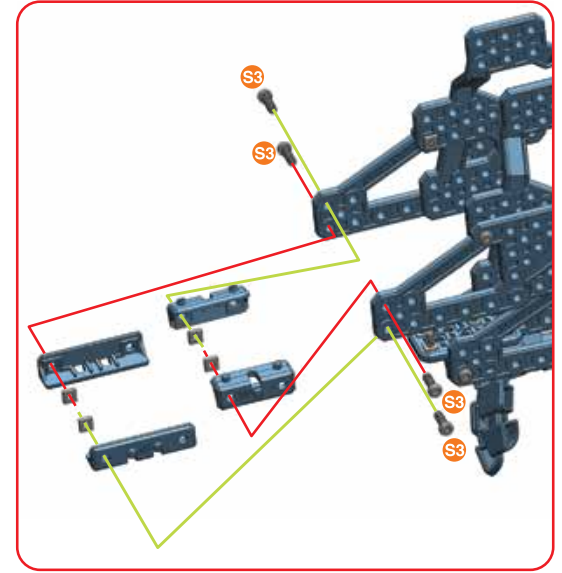
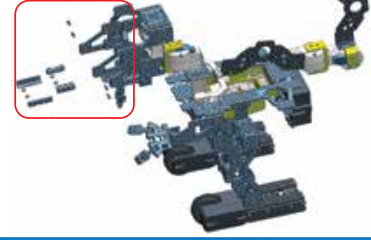

82

- x2**
- x2**
- x1**
- x1**
- x1**

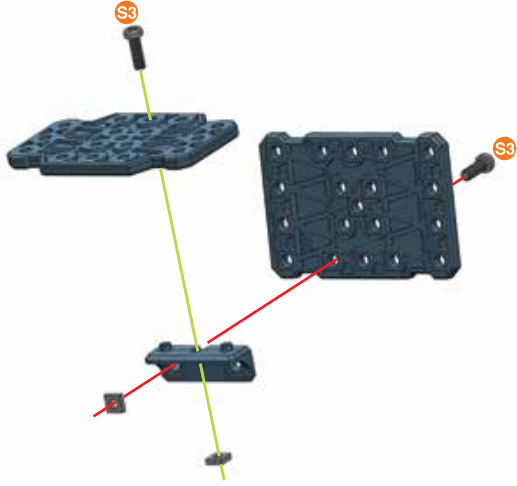



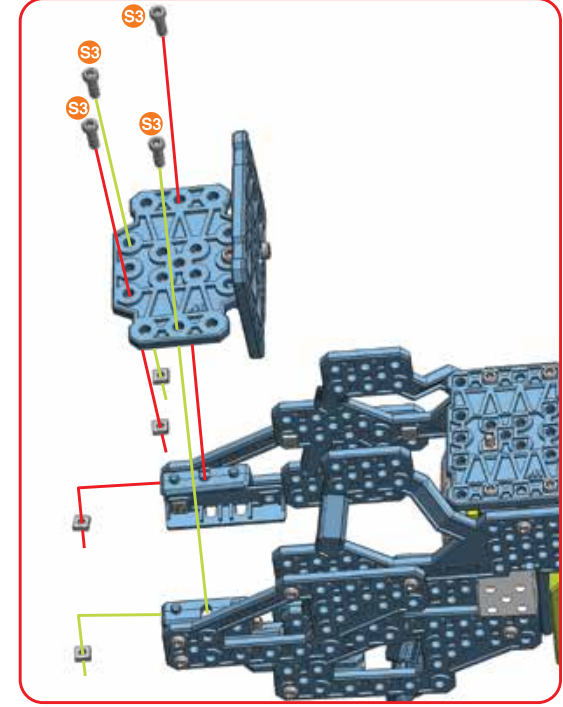
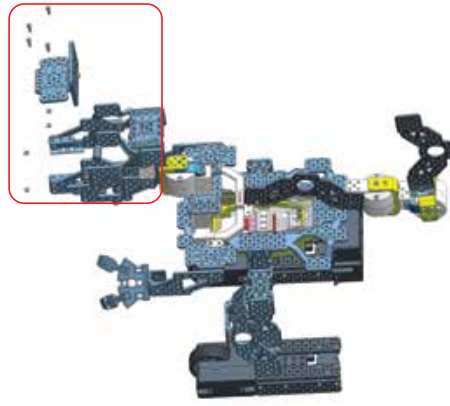

83

81+82+

- x4**
- x4**



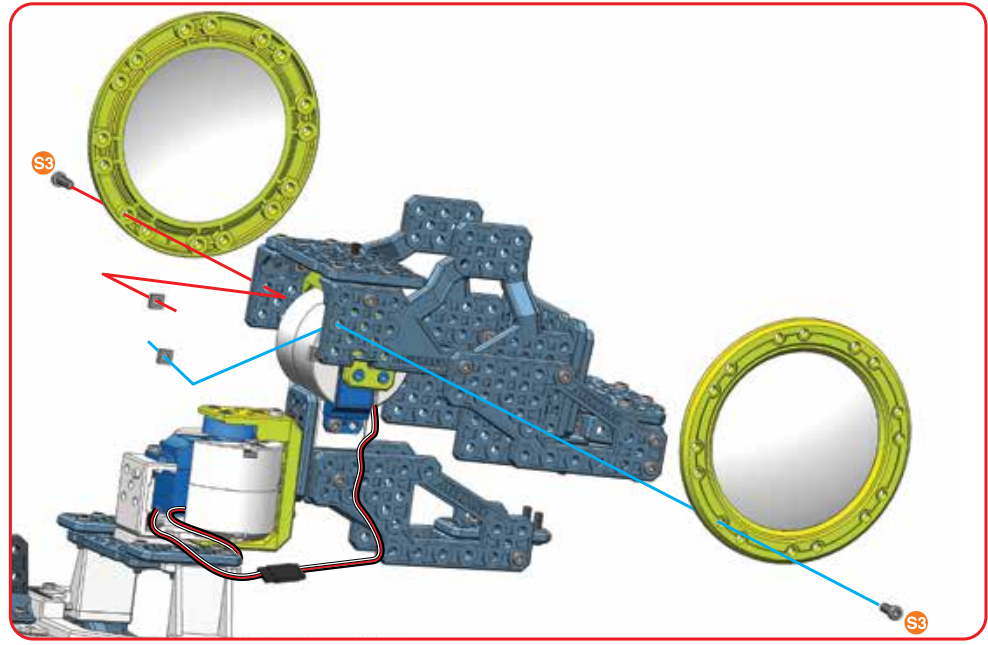
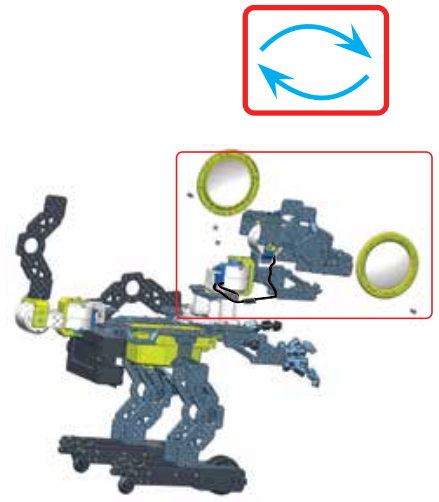

84

-  | 12 mm | **x2**  
1/2"
-  | **x2**
-  | **x2**
-  | **x1**  
1:1



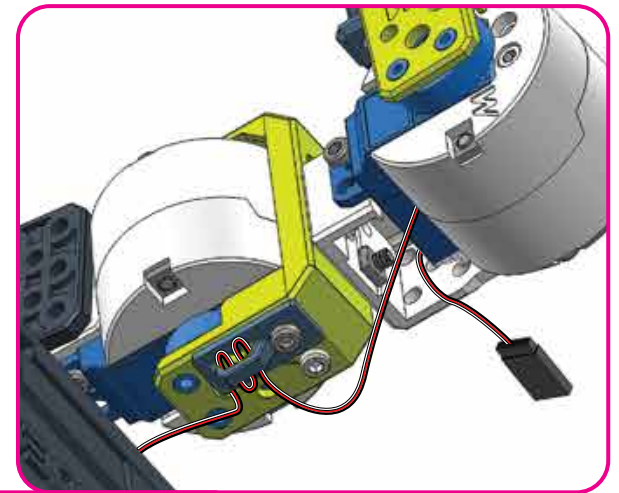
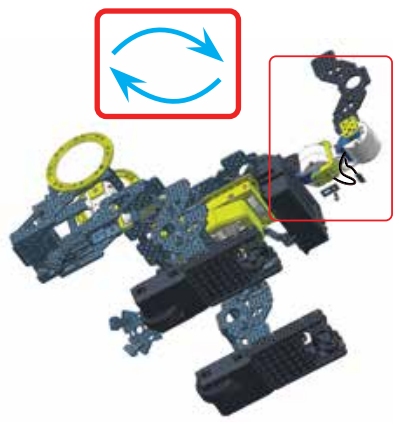

85

-  | 12 mm | **x1**  
1/2"
-  | **x1**







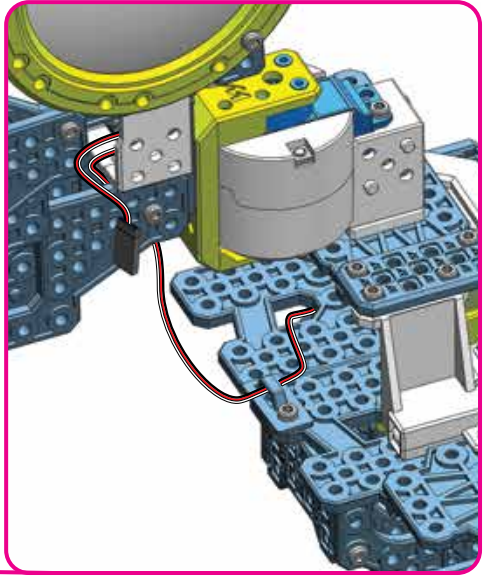
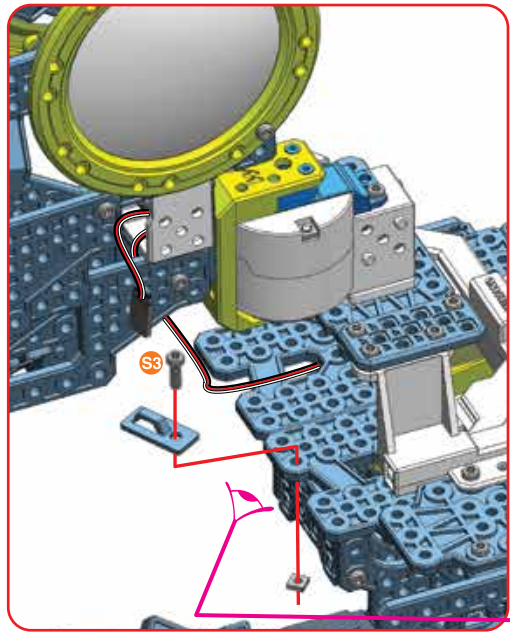
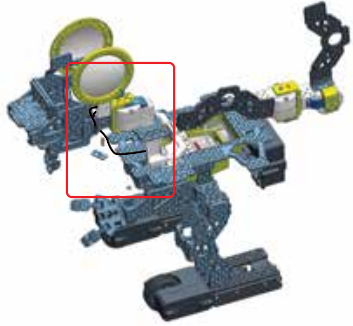

# 86

	12 mm 1/2"	x1
		x1
		x1

		1:1
---	--	-----



# 87

	12 mm 1/2"	x3
		x3
		x3

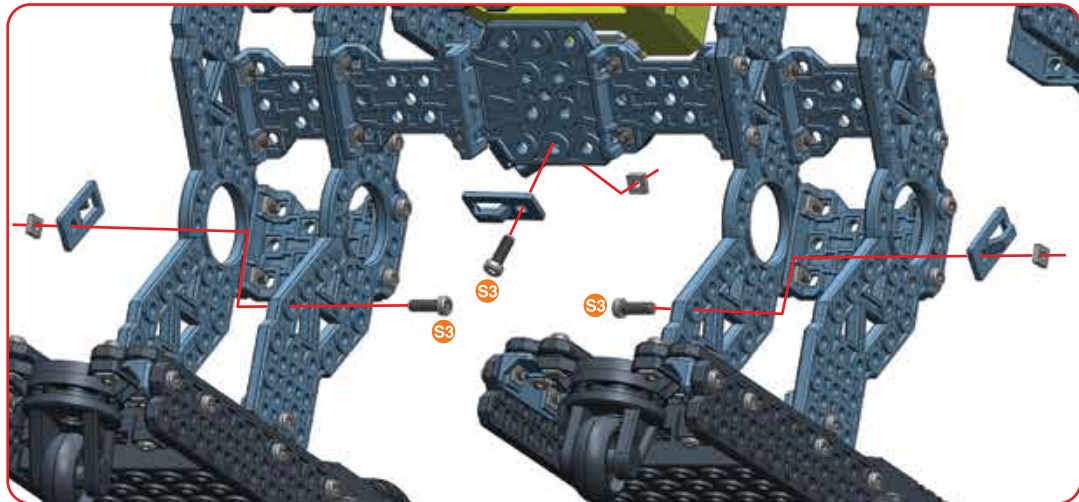
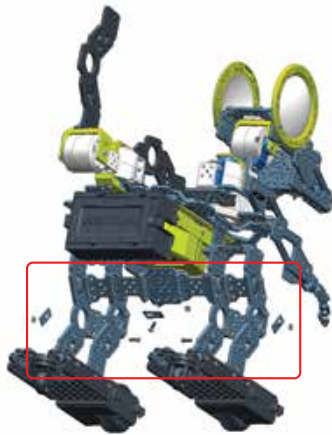
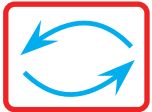

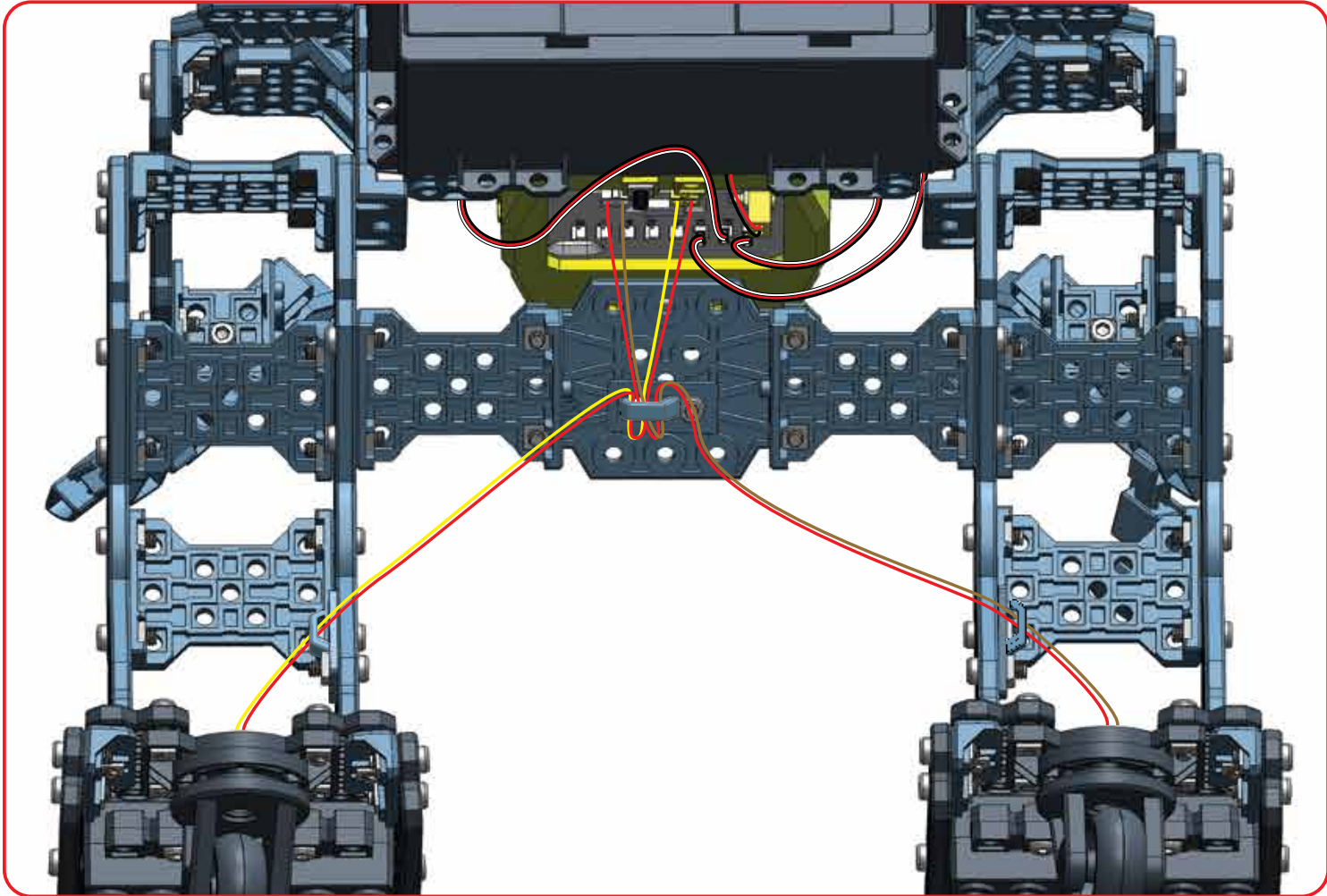
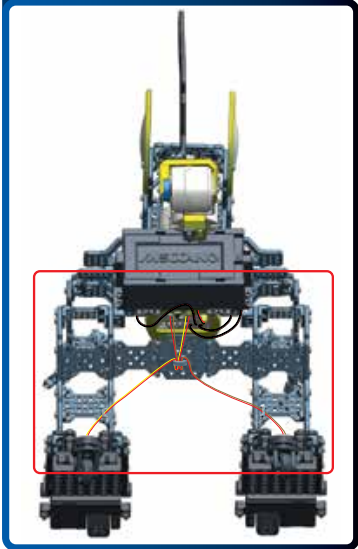

**89**

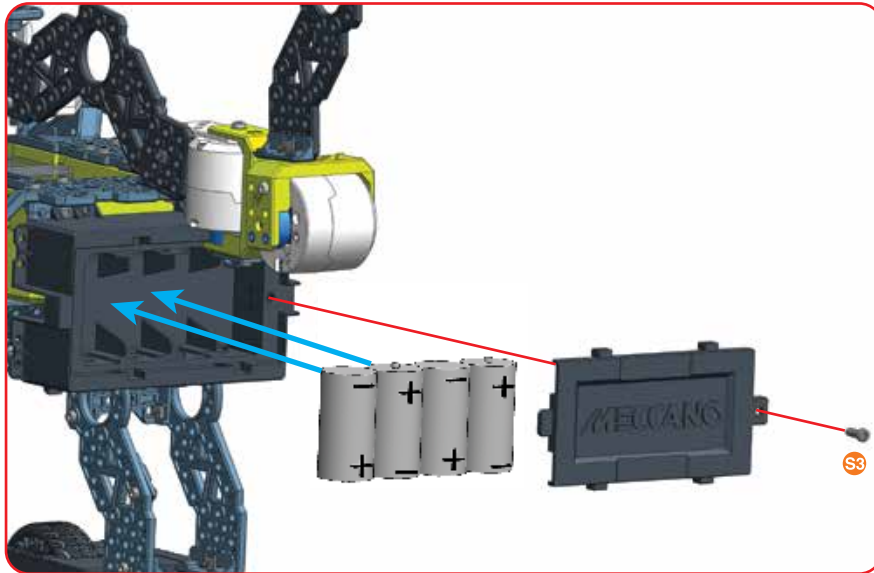
 S3 | 12 mm  
1/2" | **x1**

 S3 | **1:1**
**(GB) HOW TO INSTALL BATTERIES**

**1.** Open the battery door with a Meccano tool. **2.** If used batteries are present, remove these batteries from the unit by pulling up on one end of each battery. **DO NOT** remove or install batteries using sharp or metal tools. **3.** Install new batteries as shown in the polarity diagram (+/-) inside the battery compartment. **4.** Replace battery door securely. **5.** Check your local laws and regulations for correct recycling and/or battery disposal.

**(F) INSTALLATION DES PILES**

**1.** Ouvrir le compartiment des piles à l'aide d'un outil Meccano. **2.** S'il contient des piles usagées, les retirer en les soulevant par l'une des extrémités. **NE PAS** utiliser d'objet coupant ou métallique pour retirer ou insérer des piles. **3.** Insérer les nouvelles piles en respectant le schéma de polarité (+/-) dans le compartiment des piles. **4.** Bien refermer le compartiment des piles. **5.** Recycler ou jeter les piles usagées conformément à la législation locale.

**(E) INSTALACIÓN DE LAS PILAS**

**1.** Abra la tapa del compartimento de las pilas con una herramienta de Meccano. **2.** Si las pilas están gastadas, tire hacia arriba de uno de sus extremos para extraerlas. **NO** utilice herramientas metálicas o puntiagudas para instalar o extraer las pilas. **3.** Instale las pilas nuevas como se muestra en el esquema de polaridad (+/-) dentro del compartimento de las pilas. **4.** Vuelva a colocar la tapa del compartimento de las pilas. **5.** Consulte la normativa local relativa al reciclaje y desecho de las pilas.

**(D) EINLEGEN DER BATTERIEN**

**1.** Batteriefachabdeckung mit einem Meccano-Werkzeug öffnen. **2.** Wenn sich gebrauchte Batterien darin befinden, diese einzeln herausziehen. Batterien **NICHT** mit scharfen oder metallenen Gegenständen entfernen oder einlegen. **3.** Neue Batterien unter Beachtung des Polaritätsdiagramms (+/-) in das Batteriefach einlegen. **4.** Batteriefachabdeckung wieder anbringen. **5.** Örtliche Gesetze und Bestimmungen für das Recycling bzw. die Entsorgung von Altbatterien beachten.

**(NL) DE BATTERIJEN PLAATSEN**

**1.** Open het batterijdeksel met Meccano-gereedschap. **2.** Verwijder eventueel gebruikte aanwezige batterijen uit de unit door één kant van elke batterij omhoog te trekken. Verwijder of plaats batterijen **NIET** met behulp van scherpe of metalen voorwerpen. **3.** Plaats de nieuwe batterijen zoals weergegeven op het polariteitsdiagram (+/-) aan de binnenkant van het batterijvak. **4.** Sluit het vak af met het batterijdeksel. **5.** Lees de plaatselijke voorschriften en regelgeving om de batterijen op de juiste wijze te recyclen of af te voeren.

**(I) COME INSTALLARE LE PILE**

**1.** Aprire lo scomparto pile con un attrezzo Meccano. **2.** Se sono presenti pile usate, rimuoverle dall'unità sollevandole da un'estremità. **NON** usare oggetti metallici o appuntiti per rimuovere o installare le pile. **3.** Inserire le nuove pile seguendo il diagramma della polarità (+/-) all'interno dello scomparto pile. **4.** Riporre saldamente lo sportello dello scomparto pile. **5.** Eliminare e/o riciclare le pile secondo quanto previsto dalle normative locali vigenti.

**(P) COMO COLOCAR AS PILHAS**

**1.** Abra a tampa da bateria com uma ferramenta Meccano. **2.** Se houver pilhas usadas, retire-as da unidade individualmente, puxando pela extremidade de cada uma. **NÃO** retire ou coloque pilhas com qualquer acessório pontiagudo ou metálico. **3.** Instale pilhas novas seguindo o diagrama de polaridade (+/-) dentro do compartimento de pilhas. **4.** Coloque de novo a porta do compartimento com cuidado. **5.** Consulte as leis, as normas e os regulamentos locais de reciclagem e/ou descarte de pilhas e baterias.

**(R) УСТАНОВКА ЭЛЕМЕНТОВ ПИТАНИЯ.**

**1.** Откройте крышку отсека элементов питания инструментом Мессано. **2.** Извлеките старые или истощенные элементы питания из отсека (при их наличии), подняв каждый элемент питания за край. Запрещается извлекать или устанавливать батареи с помощью острых или металлических предметов. **3.** Установите новые элементы питания внутри отсека, соблюдая полярность (+/-). **4.** Надежно закройте крышку отсека. **5.** Ознакомьтесь с законами и нормативами вашей страны, установленными в отношении правил переработки и/или утилизации элементов питания.

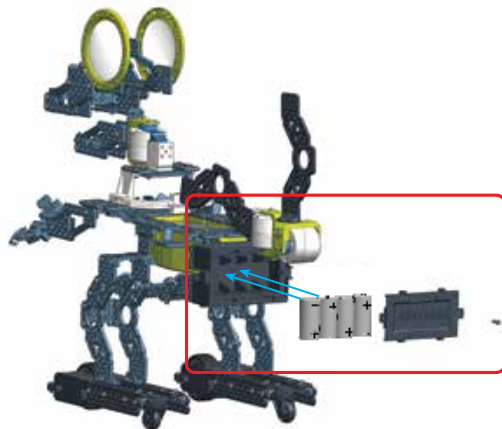

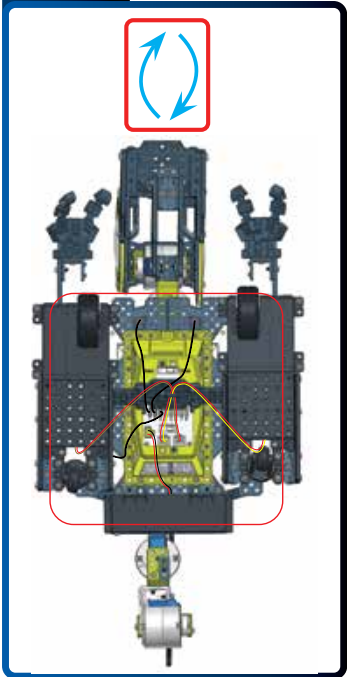

Make sure the Meccabrain is in drone mode

Turn robot on

**Well done, your build is complete.**

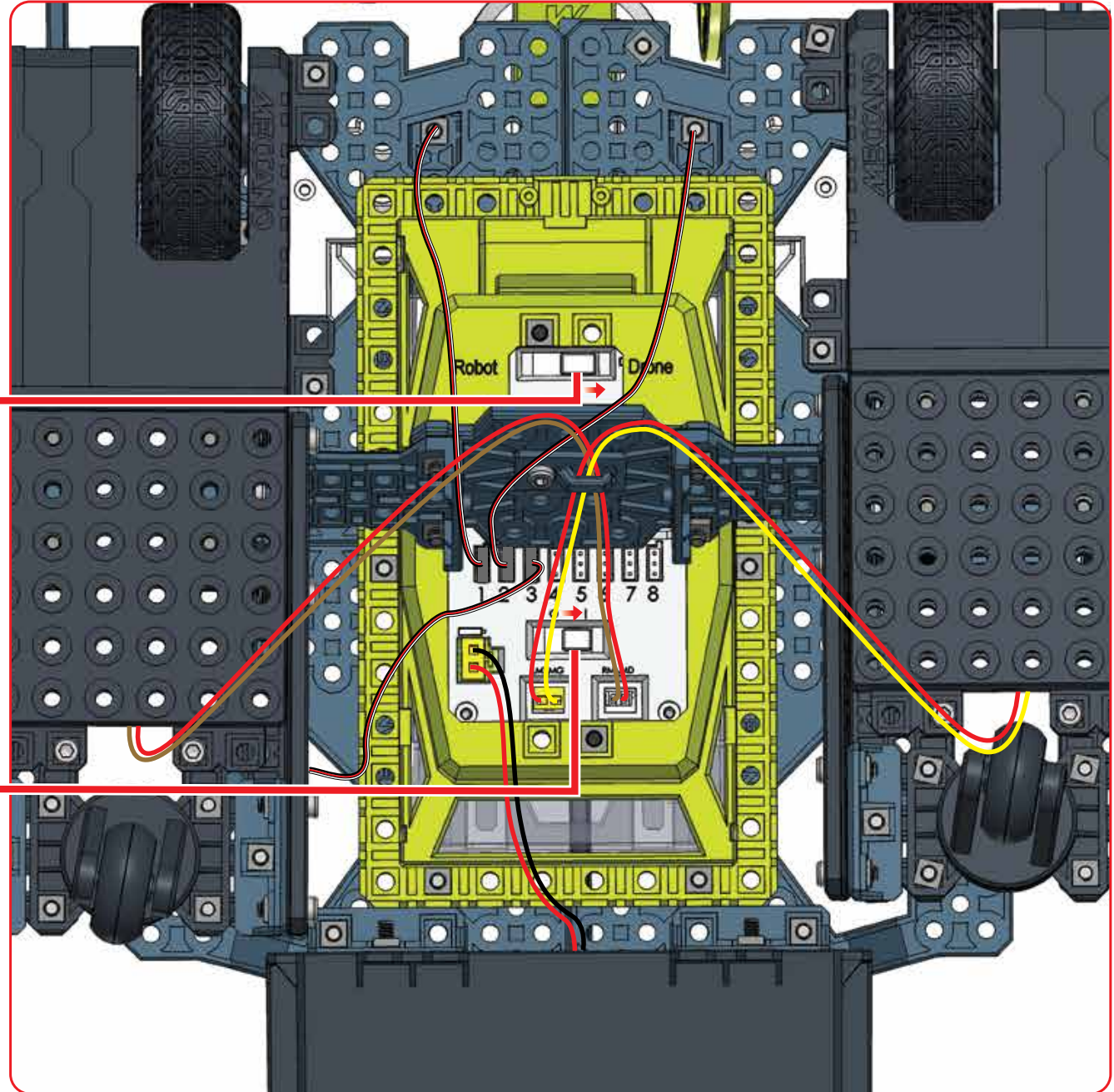

# CONSUMER INFORMATION • INFORMATIONS DESTINÉES AU CONSOMMATEUR • INFORMACION PARA EL CONSUMIDOR • VERBRAUCHERHINWEISE INFORMATIE VOOR GEBRUIKERS • INFORMAZIONI PER I CONSUMATORI • INFORMAÇÕES PARA O CONSUMIDOR • ИНФОРМАЦИЯ ДЛЯ ПОТРЕБИТЕЛЕЙ

## **GB BATTERY SAFETY INFORMATION:**

- Requires 4 x 1.5V C alkaline batteries (not included).
- Batteries are small objects.
- Replacement of batteries must be done by adults.
- Follow the polarity (+/-) diagram in the battery compartment.
- Promptly remove dead batteries from the toy.
- Dispose of used batteries properly.
- Remove batteries for prolonged storage.
- Only batteries of the same or equivalent type as recommended are to be used.
- DO NOT incinerate used batteries.
- DO NOT dispose of batteries in fire, as batteries may explode or leak.
- DO NOT mix old and new batteries or types of batteries (i.e. alkaline/standard).
- DO NOT use rechargeable batteries.
- DO NOT recharge non-rechargeable batteries.
- DO NOT short-circuit the supply terminals.

**IMPORTANT INFORMATION:** Remove all packaging before use. Retain this information, addresses and phone numbers for future reference. Content may vary from pictures. Meccano reserves the right to discontinue the website [www.meccano.com](http://www.meccano.com) at any time. Keep away from obstacles and electrical hazards.

**SAFETY PRECAUTIONS:** Parental guidance is recommended. Do not use Meccanoid on a table or near stairs; only use on the floor. Regularly examine for damage to the toy and sensors. In the event of any damage, remove from use. Keep hands, hair and loose clothing away from moving parts when power switch is turned ON. Turn OFF Meccanoid when not in use. During play, keep in sight so that you can supervise it all the time. Users should keep strict accordance with the instruction manual while operating the product.

**CARE AND MAINTENANCE:** This product is intended for indoor use only. Do not use outdoor - dirt, grass, cement will scratch the finish and/ or block the sensors. Do not submerge the toy in water. Do not play around water as this is a hazard and can cause a malfunction or damage the electronic assemblies. Keep the sensors clean, wipe with a scratchless cloth. Do not put any foreign objects in the USB port or sensors. Do not pull hard on any part of the robot as this may cause damage.

**TROUBLE SHOOTING:** If normal function of the product is disturbed or interrupted, strong electro-magnetic interference may be causing the issue. To

reset product, turn it completely off, then turn it back on. If normal operation does not resume, move the product to another location and try again. To ensure normal performance, change the batteries, as low batteries may not allow full function.

## **F INFORMATIONS DE SÉCURITÉ RELATIVES AUX PILES :**

- Fonctionne avec 4 piles alcalines C 1,5 V (non fournies).
- Les piles sont de petits objets.
- Le remplacement des piles doit être effectué par un adulte.
- Respecter le schéma de polarité (+/-) du compartiment des piles.
- Retirer immédiatement toute pile usagée du jouet.
- Jeter correctement les piles usagées.
- Retirer les piles du jouet en cas d'inutilisation prolongée.
- N'utiliser que des piles d'un même type ou d'un type équivalent à celui recommandé.
- NE PAS incinérer les piles usagées.
- NE PAS jeter les piles au feu ; elles pourraient exploser ou fuir.
- NE PAS mélanger des piles neuves et des piles usagées, ou des piles de types différents (ex : alcalines/standard).
- NE PAS utiliser de piles rechargeables.
- NE PAS recharger des piles non rechargeables.
- NE PAS court-circuiter les bornes d'alimentation.

**INFORMATIONS IMPORTANTES :** Retirer tout l'emballage avant utilisation. Conserver les informations, adresses et numéros de téléphone pour consultation ultérieure. Le contenu peut différer des images. Meccano se réserve le droit de supprimer le site Internet [www.meccano.com](http://www.meccano.com) à tout moment. Maintenir à l'écart de tout obstacle ou risque électrique.

**MESURES DE SÉCURITÉ :** L'aide d'un adulte est recommandée. Ne pas utiliser Meccanoid sur une table ou près d'escaliers. L'utiliser sur le sol uniquement. Vérifier régulièrement que le jouet et les capteurs ne sont pas endommagés. S'ils le sont, ne plus utiliser le jouet. S'assurer que les mains, cheveux et vêtements amples ne se trouvent pas à proximité des parties mobiles lorsque l'interrupteur est placé sur ON. ÉTEINDRE Meccanoid lorsqu'il n'est pas utilisé. Le jouet doit toujours être dans le champ de vision et surveillé à tout moment. Les utilisateurs doivent suivre rigoureusement les consignes de ce mode d'emploi lors de l'utilisation du jouet.

**ENTRETIEN ET MAINTENANCE :** Ce produit est conçu pour être utilisé en intérieur seulement. Ne pas utiliser en extérieur : tout contact avec de la terre, de l'herbe ou du béton peut érafler la peinture et/ou empêcher les capteurs de fonctionner. Ne pas plonger le jouet dans l'eau. Ne pas utiliser le jouet à proximité d'eau ; cela présente un danger et risquerait de provoquer un mauvais fonctionnement des assemblages électroniques ou de les endommager. Les capteurs doivent rester propres. Les nettoyer à l'aide d'un chiffon doux. Ne placer aucun objet étranger dans les capteurs ni dans le port USB. Ne pas tirer trop fort sur une partie du robot, car cela pourrait l'endommager.

**DÉPANNAGE :** de fortes interférences électromagnétiques peuvent perturber ou empêcher le fonctionnement du jouet. Pour réinitialiser le jouet, l'éteindre totalement, puis le rallumer. S'il ne fonctionne toujours pas correctement, le déplacer et réessayer. Pour assurer le fonctionnement normal du jouet, remplacer les piles. En effet, des piles faibles peuvent ne pas permettre un fonctionnement optimal.

## **E INFORMACIÓN DE SEGURIDAD SOBRE LAS PILAS:**

- Requiere 4 pilas alcalinas C de 1,5 V (no incluidas).
- Las pilas son objetos pequeños.
- Las pilas deben ser sustituidas por un adulto.
- Siga las instrucciones de polaridad (+ / -) que aparecen en el compartimento de las pilas.
- Retire rápidamente las pilas usadas.
- Las pilas usadas deben desecharse de forma adecuada.
- Retire las pilas si va a guardar el juguete durante un período de tiempo prolongado.
- Utilice únicamente pilas del tipo recomendado o de un tipo equivalente.
- NO exponga las pilas usadas al fuego.
- NO deseche las pilas usadas quemándolas, ya que podrían explotar o desprender productos químicos.
- NO mezcle pilas nuevas y viejas, ni mezcle pilas de tipos distintos (p. ej. alcalinas y normales).
- NO utilice pilas recargables.
- NO intente recargar pilas no recargables.
- NO cause cortocircuitos en las terminales de corriente.

**INFORMACIÓN IMPORTANTE :** Retire todo el embalaje antes de utilizar el producto. Conserve toda la información, las direcciones y los números de teléfono para futuras referencias. El contenido del paquete puede no corresponder con las imágenes. Meccano se reserva el derecho a suspender el sitio web [www.meccano.com](http://www.meccano.com) en cualquier momento. Mantenga el producto alejado de obstáculos y riesgos eléctricos.

**MEDIDAS DE SEGURIDAD:** Se recomienda la supervisión

de un adulto. Coloca tu Meccanoid en el suelo cuando vayas a utilizarlo, nunca en una mesa ni cerca de las escaleras. Comprueba periódicamente si el juguete o los sensores han sufrido daños. En caso de que estén dañados, deja de utilizar el juguete. Mantén las manos, el pelo y la ropa alejados del juguete cuando el interruptor esté en posición de ENCENDIDO. APAGA tu Meccanoid cuando no vayas a utilizarlo. No lo pierdas de vista mientras lo estás usando; debe estar bajo control en todo momento. Los usuarios del producto deben seguir todas las recomendaciones de esta guía de instrucciones.

**CUIDADO Y MANTENIMIENTO:** este producto debe utilizarse únicamente en interiores. No lo utilices en exteriores, ya que la suciedad, la hierba y el cemento pueden arañar el acabado y bloquear los sensores. No sumerjas el juguete en agua. No utilices el juguete cerca del agua. Esto puede resultar muy peligroso ya que podría provocar un mal funcionamiento o dañar los componentes electrónicos. Mantén limpios los sensores; límpialos con un paño suave. No insertes objetos extraños en el puerto USB ni en los sensores. No tires con fuerza de ninguna parte del robot, ya que podrías dañarlo.

**RESOLUCIÓN DE PROBLEMAS:** si se interrumpe el funcionamiento normal del producto, es posible que se deba a interferencias electromagnéticas fuertes. Para reiniciarlo, apágalo y vuelve a encenderlo. Si el producto sigue sin funcionar normalmente, cambia la zona de uso y vuelve a intentarlo. Las pilas usadas pueden impedir que el producto funcione correctamente. Para conseguir un rendimiento óptimo, cambia las pilas.

## **D SICHERHEITSHINWEISE ZU BATTERIEN:**

- Benötigt 4 x 1,5-V-Alkali-Babyzellen C (nicht enthalten).
- Batterien sind kleine Gegenstände.
- Batterien müssen von Erwachsenen ausgewechselt werden.
- Das Polaritätsdiagramm (+/-) im Batteriefach beachten.
- Leere Batterien sofort aus dem Spielzeug entfernen.
- Verbrauchte Batterien ordnungsgemäß entsorgen.
- Bei längerfristiger Lagerung Batterien vorher entfernen.
- Nur dieselben oder gleichwertige Batterien wie empfohlen verwenden.
- Verbrauchte Batterien NICHT verbrennen.
- Batterien NICHT in Feuer entsorgen, da sie explodieren oder auslaufen könnten.
- Alte und neue Batterien oder verschiedene Batterietypen (z. B. Alkali/Standard) NICHT zusammen einlegen.
- KEINE aufladbaren Batterien verwenden.
- Nicht-aufladbare Batterien NICHT aufladen.
- Batteriepole NICHT kurzschließen.

**WICHTIGE INFORMATIE:** Entfernen Sie vor der Benutzung sämtliche Verpackungsmaterialien. Alle Informationen, Adressen und Telefonnummern bitte für mögliche Rückfragen aufbewahren. Der Packungsinhalt kann von den Bildern abweichen. Meccano behält sich das Recht vor, den Betrieb der Website [www.meccano.com](http://www.meccano.com) jederzeit einzustellen. Nicht in der Nähe von Hindernissen und gefährlichen Stromquellen spielen.

**SICHERHEITSVORKEHRUNGEN:** Beaufsichtigung durch Erwachsene empfohlen. Meccanoid nicht auf Tischen oder in der Nähe von Treppen verwenden. Das Spielzeug ist ausschließlich für die Verwendung auf dem Boden gedacht. Das Spielzeug und die Sensoren regelmäßig auf Schäden untersuchen. Ist das Spielzeug beschädigt, darf es nicht länger verwendet werden. Hände, Haare und weite Kleidung von den beweglichen Teilen fernhalten, wenn das Spielzeug eingeschaltet ist. Meccanoid ausschalten, wenn das Spielzeug nicht verwendet wird. Kinder während des Spielens mit Meccanoid nicht unbeaufsichtigt lassen. Das Produkt sollte streng nach den Anweisungen in der Bedienungsanleitung verwendet werden.

**PFLGE UND WARTUNG:** Dieses Produkt ist nur zur Verwendung in Innenräumen vorgesehen. Nicht im Freien verwenden. – Schmutz, Gras und Asphalt können die Oberfläche zerkratzen und/oder die Sensoren blockieren. Das Spielzeug nicht unter Wasser tauchen. Das Spielzeug nicht in der Nähe von Wasser verwenden. Dies ist nicht nur gefährlich, sondern kann auch zu einer Fehlfunktion oder zur Beschädigung der elektronischen Komponenten führen. Die Sensoren mit einem weichen Tuch sauber halten. Keine Fremdkörper in den USB-Anschluss oder die Sensoren einführen. Nicht an Roboterteilen zerran, denn das kann Schäden verursachen.

**FEHLERBEHEBUNG:** Wenn die normale Funktion des Produkts gestört oder unterbrochen wird, könnte starke elektromagnetische Strahlung der Grund dafür sein. Durch Aus- und wieder Einschalten des Produkts können die Einstellungen zurückgesetzt werden. Sollte dies die Fehlfunktion nicht beheben, das Produkt an einen anderen Ort bringen und dort erneut ausprobieren. Bei Bedarf die Batterien austauschen, da schwache Batterien die Leistungsfähigkeit beeinträchtigen können.

#### **(NL) VEILIGHEIDSINFORMATIE MET BETREKKING TOT DE BATTERIJEN:**

- Vereist 4 C alkalinebatterijen van 1,5 V (niet inbegrepen).
- Batterijen zijn kleine voorwerpen.
- Het vervangen van batterijen dient door volwassenen te worden gedaan.
- Houd je aan het polariteitsdiagram (+/-) in het batterijvak.
- Verwijder lege batterijen onmiddellijk uit het speelgoed.
- Zorg voor een milieuvriendelijke afvalverwerking van de batterijen.

- Verwijder de batterijen als het speelgoed voor langere tijd wordt opgeborgen.
- Alleen batterijen van het aanbevolen type of een equivalent daarvan mogen worden gebruikt.
- Steek gebruikte batterijen NOOIT in brand.
- Gooi batterijen NOOIT in vuur. Hierdoor kunnen deze ontploffen of gaan lekken.
- Gebruik oude en nieuwe batterijen of verschillende typen batterijen (bijv. alkaline/standaard) NOOIT door elkaar.
- Gebruik NOOIT oplaadbare batterijen.
- Laad niet-oplaadbare batterijen NOOIT op.
- Veroorzaak NOOIT kortsluiting tussen de contactpunten.

**BELANGRIJKE INFORMATIE:** Verwijder de verpakking voor gebruik. Bewaar deze informatie, adressen en telefoonnummers voor toekomstig gebruik. Inhoud kan afwijken van illustraties. Meccano behoudt zich het recht voor de website [www.meccano.com](http://www.meccano.com) wanneer gewenst buiten gebruik te stellen. Blijf uit de buurt van obstakels en voorwerpen die elektrische schokken kunnen veroorzaken.

**VEILIGHEIDSMATREGELEN:** Ouderlijk toezicht wordt aanbevolen. Gebruik Meccanoid niet op tafels of in de buurt van trappen. Gebruik Meccanoid alleen op de vloer. Controleer het speelgoed en de sensoren regelmatig op beschadigingen. In geval van schade, speelgoed niet meer gebruiken. Houd handen, haar en losvallende kleding uit de buurt van bewegende onderdelen als de stroomschakelaar op ON staat. Zet Meccanoid uit wanneer je hem niet gebruikt. Houd Meccanoid tijdens het spelen altijd in de gaten. Gebruikers dienen zich tijdens het gebruik van het product strikt aan de informatie in de gebruiksaanwijzing te houden.

**VERZORGING EN ONDERHOUD:** dit product is uitsluitend voor gebruik binnenshuis. Gebruik het product niet buitenshuis. Vuil, gras en cement zorgen voor krassen op de lak of blokkeren de sensoren. Dompel het speelgoed niet onder in water. Gebruik het speelgoed niet in de buurt van water, omdat dit gevaarlijk is en een elektronisch defect kan veroorzaken. Maak de sensoren schoon met een zachte doek. Plaats geen vreemde objecten in de USB-poort of de sensoren. Trek niet hard aan de onderdelen van de robot omdat dit schade kan veroorzaken.

**PROBLEMEN OPLOSSEN:** bij ontregeling of onderbreking van het normale functioneren van het product kan een sterke elektromagnetische storing de oorzaak van het probleem zijn. Reset het product door het volledig uit te schakelen en vervolgens weer in te schakelen. Functioneert het product dan nog niet naar behoren, reset het dan nogmaals in een andere ruimte. Controleer ook of de batterijen niet leeg zijn en vervang deze indien nodig. Lege batterijen kunnen een correcte werking verstoren.

#### **(I) INFORMAZIONI DI SICUREZZA PER LE PILE:**

- Richiede 4 pile alcaline C da 1,5 V (non incluse).
- Le pile sono oggetti di piccole dimensioni.
- Le pile devono essere sostituite da adulti.
- Far riferimento allo schema delle polarità (+/-) all'interno dello scomparto pile.
- Estrarre tempestivamente le pile scariche.
- Eliminare le pile scariche con la dovuta cautela.
- Estrarre le pile se non si utilizza il prodotto per un periodo di tempo prolungato.
- Usare solo pile dello stesso tipo o equivalenti.
- NON bruciare le pile usate.
- NON gettare le pile nel fuoco, potrebbero esplodere o essere soggette a perdite di liquido.
- NON mischiare pile vecchie e nuove o tipi di pile diverse (ad esempio alcaline e standard).
- NON usare pile ricaricabili.
- NON ricaricare le pile non ricaricabili.
- NON cortocircuitare i terminali delle pile.

**INFORMAZIONI IMPORTANTI:** Rimuovere l'imballo prima dell'uso. Conservare informazioni, indirizzi e numeri di telefono per riferimento futuro. Il prodotto potrebbe essere differente dalle immagini. Meccano si riserva il diritto di rimuovere il sito [www.meccano.com](http://www.meccano.com) in qualsiasi momento. Tenere lontano da ostacoli, dispositivi elettrici e prese di corrente.

**PRECAUZIONI DI SICUREZZA:** È consigliata la supervisione dei genitori. Non usare Meccanoid su un tavolo o in prossimità di scale. Usare solo sul pavimento. Esaminare regolarmente il giocattolo e i sensori per verificare l'eventuale presenza di danni. Se danneggiato, il giocattolo non deve essere usato. Tenere le mani, i capelli e i capi di vestiario lontani dai componenti in movimento quando l'interruttore di alimentazione è acceso. Spegnerne Meccanoid quando non lo si sta usando. Durante il gioco, tenere Meccanoid™ in vista per poterlo controllare in ogni momento. Seguire attentamente la guida per l'uso.

**CONSERVAZIONE E MANUTENZIONE:** questo prodotto deve essere utilizzato esclusivamente in luoghi chiusi. Non utilizzare all'esterno: terra, erba e cemento potrebbero graffiare la superficie e/o potrebbero bloccare i sensori. Non immergere il giocattolo in acqua. Non utilizzare in prossimità di acqua per evitare il rischio di malfunzionamenti o danni ai componenti elettronici. Tenere puliti i sensori utilizzando un panno antigraffio. Non inserire corpi estranei nella porta USB o nei sensori. Non tirare troppo forte nessun componente del robot per evitare danni.

**RISOLUZIONE DEI PROBLEMI:** se il normale funzionamento del prodotto risultasse disturbato, ciò potrebbe essere causato da una forte interferenza elettromagnetica. Per resettare il prodotto, spegnerlo e riaccenderlo. Se non dovesse riprendere a funzionare

adeguatamente, spostarlo in una posizione diversa e riprovare. Per un funzionamento corretto, sostituire le pile poco cariche che possono compromettere il regolare funzionamento del prodotto.

#### **(P) INFORMAÇÕES DE SEGURANÇA SOBRE AS PILHAS:**

- Requer 4 pilhas alcalinas tipo C de 1,5 V (não incluídas).
- Pilhas são objetos pequenos.
- A troca das pilhas deve ser realizada por adultos.
- Siga o diagrama de polaridade (+/-) no compartimento de pilhas.
- Retire as pilhas vazias do brinquedo.
- Descarte corretamente as pilhas usadas.
- Retire as pilhas para armazenamento prolongado.
- Recomenda-se que sejam usadas apenas pilhas iguais ou similares.
- NÃO incinere as pilhas usadas.
- NÃO jogue as pilhas no fogo, pois podem explodir ou vazar.
- NÃO misture pilhas novas com usadas, tampouco misture tipos de pilhas diferentes (pilhas alcalinas com pilhas regulares, por exemplo).
- NÃO use pilhas recarregáveis.
- NÃO recarregue pilhas não recarregáveis.
- NÃO permita que ocorra curto-circuito nos terminais do produto.

**IMPORTANTE:** emova totalmente a embalagem antes de utilizar. Guarde todos os endereços, números de telefone e demais informações para consulta e referência. O conteúdo poderá ser diferente das ilustrações. A Meccano reserva-se o direito de descontinuar o sítio [www.meccano.com](http://www.meccano.com) a qualquer altura. Mantenha distância de obstáculos e perigos elétricos.

**PRECAUÇÕES DE SEGURANÇA:** É recomendada a supervisão de um adulto. Não use o Meccanoid em mesas ou perto de escadas, apenas no chão. Verifique regularmente se há danos no brinquedo e nos sensores. Em caso de algum dano, suspenda o uso. Mantenha mãos, cabelos e roupas distantes do brinquedo quando a chave de liga/desliga estiver em "ON" ("LIGADO"). DESLIGUE o Meccanoid quando não estiver em uso. Ao brincar com o produto, mantenha-o sob sua supervisão em todos os momentos. Os usuários devem seguir todas as instruções do guia de instruções para usar o brinquedo.

**CUIDADOS E MANUTENÇÃO:** Este produto destina-se somente a uso interno. Não o use fora de casa - pó, grama e cimento arranharão o acabamento e/ou obstruirão os sensores. Não submerja o brinquedo em água. Não brinque perto da água, pois isso representa um risco e pode causar mau funcionamento ou danos aos componentes eletrônicos. Mantenha os sensores limpos

usando um tecido macio. Não insira objetos estranhos na porta USB ou nos sensores. Não puxe com muita força nenhuma parte do robô para não causar danos.

**SOLUÇÃO DE PROBLEMAS:** Se o funcionamento normal do produto for afetado ou interrompido, a causa pode ser uma interferência eletromagnética. Para reiniciar o produto, desligue-o completamente e ligue-o novamente. Se o funcionamento não voltar ao normal, desligue o produto para o outro local e tente novamente. Para garantir o funcionamento normal, troque as pilhas, já que as pilhas com carga baixa não possibilitam o funcionamento completo do produto.

### **(B) INFORMAÇÃO PO BEZOPASNOMU OBRASHENIU S ELEMENTAMI PITANIYA:**

- Требуются 4 щелочных элемента питания типа С с напряжением 1,5 В (не входят в комплект).
- Элементы питания представляют собой миниатюрные предметы.
- Замену элементов питания должны выполнять взрослые.
- Соблюдайте полярность (+/-), указанную в отсеке элементов питания.
- Не оставляйте разрядившиеся элементы питания в игрушке.
- Утилизируйте элементы питания надлежащим образом.
- Извлекайте элементы питания, если игрушка не используется долгое время.
- Рекомендуется использовать элементы питания одного или эквивалентного типа.
- НЕ сжигайте использованные элементы питания.
- НЕ бросайте элементы питания в огонь. Это может привести к их утечке или взрыву.
- НЕ используйте новые элементы питания в сочетании с использованными или элементы питания разного типа (т.е. щелочные/обычные).
- НЕ используйте перезаряжаемые элементы питания.
- ЗАПРЕЩАЕТСЯ заряжать непerezаряжаемые элементы питания.
- ИЗБЕГАЙТЕ короткого замыкания источников питания.

**ВАЖНАЯ ИНФОРМАЦИЯ:** Снимите все упаковочные материалы перед использованием. Запишите указанные на упаковке адреса и номера телефонов, чтобы у вас была возможность связаться с нами.

Содержимое упаковки может отличаться от иллюстрации. Взрослым следует время от времени проверять игру и следить за тем, чтобы она не была сломана и не представляла

опасности для ребенка. В противном случае ее не следует использовать. Во время игры дети должны находиться под присмотром взрослых. Компания Мессано оставляет за собой право прекратить использование сайта [www.messano.com](http://www.messano.com) в любое время.

**МЕРЫ ПРЕДОСТОРОЖНОСТИ:** Рекомендуется присмотр взрослых. Не используйте игрушку Мессаноид на столе или рядом с лестницей — игрушка предназначена для использования на полу. Следует проводить регулярный осмотр на предмет повреждения игрушки и датчиков. Если таковые имеются, игрушку не следует использовать. Не прикасайтесь к игрушке руками и следите за тем, чтобы она находилась на безопасном расстоянии от волос и неприлегающих элементов одежды, когда переключатель питания находится в положении “ВКЛ.”. Выключите игрушку, когда она не используется. Во время использования игрушка всегда должна находиться в поле зрения. При управлении игрушкой необходимо строго следовать указаниям, приведенным в руководстве по эксплуатации.

**УХОД И ОБСЛУЖИВАНИЕ:** игрушка предназначена только для использования в помещении. Не используйте игрушку на улице — грязь, трава и бетон могут поцарапать покрытие и/или повредить датчики. Не погружайте игрушку в воду. Не используйте игрушку рядом с водой, так как это может привести к сбою в работе или повреждению электронных компонентов. Очистку датчиков следует выполнять мягкой тканью. Не помещайте посторонние предметы в USB-порт или датчики. Не подвергайте части тела робота сильному растяжению, поскольку это может привести к повреждению.

устройство перестает работать или работает нестабильно, причиной могут быть сильные электромагнитные помехи. Чтобы восстановить работу устройства, полностью выключите его, а затем включите снова. Если устройство по-прежнему будет работать неисправно, повторите процедуру в другом месте комнаты. Для нормальной работы устройства замените элементы питания. При низком уровне заряда элементы питания могут быть неспособны обеспечить работу устройства в полнофункциональном режиме.



**(GB)** Requires 4 X1.5 V C alkaline batteries (not included). Batteries or battery packs must be recycled or disposed of properly. When this product has reached the end of its useful life it should not be disposed of with other household waste. The Waste Electrical and Electronic Equipment Regulations require it to be separately collected so that it can be treated using the best available recovery and recycling techniques. This will minimize the impact on the environment and human health from soil and water contamination by any hazardous substances, decrease the resources required to make new products and avoid using up landfill space. Please do your part by keeping this product out of the municipal waste stream! The “wheelie bin” symbol means that it should be collected as “waste electrical and electronic equipment”. You can return an old product to your retailer when you buy a similar new one. For other options, please contact your local council.

**(F)** Fonctionne avec 4 piles alcalines C 1,5 V (non fournies). Les piles et batteries doivent être recyclées ou mises au rebut conformément aux réglementations en vigueur. Lorsque ce produit a atteint la fin de sa durée de vie utile, il ne peut pas être jeté avec les ordures ménagères. La directive DEEE (déchets d'équipements électriques et électroniques) exige que le produit soit collecté séparément, afin qu'il puisse être traité en utilisant les meilleures techniques de valorisation et de recyclage disponibles. Cela réduira la contamination des eaux et du sol par des substances dangereuses pour l'Homme et l'environnement, les ressources nécessaires à la fabrication de nouveaux produits ainsi que les besoins de mise en décharge. Participez à ces efforts pour la planète, ne laissez pas ce produit entrer dans le flux des déchets municipaux. Le symbole représentant une poubelle indique que le produit doit être collecté en tant que déchet d'équipement électrique et électronique. Vous pouvez également rapporter un produit usagé chez votre détaillant lorsque vous achetez un produit similaire. Pour connaître les autres possibilités, veuillez contacter votre conseil municipal.

**(E)** Requiere 4 pilas alcalinas C de 1,5 V (no incluidas). Las baterías o paquetes de baterías deben reciclarse, o desecharse de forma adecuada. Cuando este producto alcance el final de su vida útil, no lo deseche como residuo doméstico. La normativa de residuos de aparatos eléctricos y electrónicos exige que se recojan de forma separada, para que puedan tratarse con las mejores técnicas de recuperación y reciclaje disponibles. De esta forma, se minimizará el impacto que la contaminación del suelo y el agua, causada por sustancias peligrosas, tiene sobre el medio ambiente y la salud humana, se reducirán los recursos necesarios para fabricar nuevos productos y se evitará la saturación de los vertederos. ¡Colabore desechando este producto de forma adecuada! El símbolo del contenedor con ruedas significa que debe desecharse como “residuo de aparatos eléctricos y electrónicos”.

Puede devolver un producto viejo en su establecimiento habitual cuando adquiera un producto nuevo similar. Si desea obtener más información, consulte con las autoridades locales.

**(D)** Benötigt 4 x 1,5-V-Alkali-Babyzellen C (nicht enthalten). Batterien oder Akkus müssen recycelt oder ordnungsgemäß entsorgt werden. Ist das Gerät nicht mehr zu gebrauchen, darf es nicht über den Hausmüll entsorgt werden. Die Elektroaltgeräteverordnung sieht vor, dass das Gerät separat entsorgt wird, damit es so weit wie möglich recycelt werden kann. Dadurch lässt sich die Menge an umwelt- und gesundheitsschädlichen Substanzen, die über den Boden und das Grundwasser in den menschlichen Nahrungskreislauf gelangen könnten, minimieren sowie die für die Herstellung neuer Produkte erforderlichen Ressourcen reduzieren und Platz auf Mülldeponien sparen. Leisten Sie bitte Ihren Beitrag dazu, indem Sie das Gerät nicht über den Hausmüll entsorgen. Das Mülltonnen-Symbol bedeutet, dass das Gerät gemäß den Vorschriften für Elektro- und Elektronikgeräte entsorgt werden muss. Alte Geräte können oft beim Kauf eines neuen, ähnlichen Geräts im Einzelhandel zurückgegeben werden. Weitere Entsorgungsmöglichkeiten erfragen Sie bitte bei Ihrer Gemeindeverwaltung.

**(NL)** Vereist 4 C alkalinebatterijen van 1,5 V (niet inbegrepen). Batterijen en accu's dienen op de juiste wijze te worden gerecycled of afgevoerd. Wanneer dit product het einde van zijn levensduur heeft bereikt, mag het niet samen met ander huishoudelijk afval worden weggegooid. Volgens de wet moet het product afzonderlijk worden ingezameld zodat het kan worden behandeld met de best beschikbare hergebruik- en recycletechnieken. Op deze manier wordt de invloed op het milieu en de menselijke gezondheid van grond- en watervervuiling door gevaarlijke stoffen geminimaliseerd, hoeven er minder bronnen te worden gebruikt om nieuwe producten te maken en raken stortplaatsen minder snel vol. Draag je steentje bij door r dit product uit de gemeentelijke afvalstroom te houden! Het afvalcontainersymbool betekent dat het product moet worden ingezameld als elektrische en elektronische afvalapparatuur. Je kunt een oud product inruilen bij de detailhandelaar wanneer je een vergelijkbaar nieuw product koopt. Neem voor andere opties contact op met de gemeente.

**(I)** Richiede 4 pile alcaline C da 1,5 V (non incluse). Le batterie e le loro confezioni devono essere riciclate o smaltite correttamente. Non smaltire il prodotto assieme ai rifiuti generici. La direttiva per lo smaltimento di apparecchiature elettriche ed elettroniche prevede che tali rifiuti siano raccolti separatamente, in modo da essere smaltiti utilizzando le più efficaci tecniche di riciclo e di recupero disponibili. Ciò consente di contenere l'impatto sull'ambiente e sulla salute umana,

evitando che il terreno e l'acqua siano contaminati da sostanze nocive, di ridurre l'uso delle risorse necessarie alla realizzazione di nuovi prodotti e di limitare il ricorso a discariche. Non gettare il prodotto assieme ai rifiuti generici. Il simbolo del contenitore per i rifiuti indica che il prodotto deve essere smaltito come "apparecchiatura elettrica ed elettronica". In caso di acquisto di un giocattolo analogo, è possibile restituire il prodotto usato al rivenditore. Per ulteriori informazioni circa lo smaltimento del prodotto, contattare le autorità locali preposte al servizio.

**P** Requer 4 pilhas alcalinas tipo C de 1,5 V (não inclusas). As baterias e as suas embalagens devem ser recicladas ou descartadas corretamente. Quando o produto alcançar o fim de sua vida útil, não o descarte com o lixo doméstico. As regulamentações para descarte de resíduos elétricos e eletrônicos solicitam que o produto seja recolhido para ser tratado usando as melhores técnicas de recuperação e reciclagem disponíveis. Isso minimizará os impactos no meio ambiente e na saúde humana pela contaminação do solo e da água por substâncias perigosas, diminuirá os recursos necessários para a produção de novos produtos e evitará o uso de aterros. Colabore! Mantenha este produto fora do fluxo de resíduos urbanos! O símbolo de reciclagem significa que tais produtos devem ser recolhidos como "descarte de equipamentos eletrônicos e elétricos". É possível devolver o produto antigo ao comerciante quando comprar um novo equivalente. Para outras opções, entre em contato com o conselho municipal.

**R** Требуются 4 щелочных элемента питания типа С с напряжением 1,5 В (не входят в комплект). Элементы питания и комплекты элементов питания необходимо утилизировать надлежащим образом. По окончании срока эксплуатации не выбрасывайте игрушку вместе с бытовыми

отходами. Согласно закону об утилизации электрических и электронных устройств ее необходимо утилизировать отдельным способом, с использованием наиболее подходящих технологий утилизации и переработки. Это позволит снизить негативные последствия для окружающей среды и здоровья человека, уменьшит загрязнение воды и почвы опасными веществами, а также снизит количество ресурсов, необходимых для изготовления новых игрушек и сократит объем мусора на городских свалках. Внесите свой вклад, сохранив город чистым. Значок с изображением перечеркнутой корзины означает, что игрушку следует утилизировать согласно закону об утилизации электрических и электронных устройств. При покупке новой игрушки вы можете вернуть старую в магазин. Чтобы узнать о других возможных вариантах утилизации, обратитесь в местную перерабатывающую организацию.

- ⚠ **WARNING: CHOKING HAZARD** – Small parts.
- ⚠ **ATTENTION ! RISQUE D'ÉTOUFFEMENT** – Contient de petits éléments.
- ⚠ **ADVERTENCIA: PELIGRO DE ASFIXIA** – Contiene piezas pequeñas. No conveniente para niños menores de 3 años.
- ⚠ **ACHTUNG: ERSTICKUNGSGEFAHR** – Kleinteile.
- ⚠ **WAARSCHUWING: VERSTIKKINGSGEVAAR** – Kleine onderdelen.
- ⚠ **ATTENZIONE: RISCHIO DI SOFFOCAMENTO** - Contiene pezzi di piccole dimensioni.
- ⚠ **AVISO: RISCO DE ASFIXIA** — Peças pequenas.
- ⚠ **ОСТОРОЖНО!** - ОПАСНОСТЬ УДУШЬЯ - Мелкие детали!



**GB.** Spin Master International SARL, hereby declares that this Meccanoid G15™ is in compliance with the essential requirements and other relevant provisions of Directive 1999/5/EC. A copy of the declaration of conformity can be requested through [customercare@spinmaster.com](mailto:customercare@spinmaster.com) or SPIN MASTER INTERNATIONAL S.A.R.L., 16 Avenue Pasteur, L-2310, Luxembourg.

**F.** Par la présente, Spin Master International SARL déclare que ce jouet Meccanoid G15™ respecte les principales exigences ainsi que les dispositions pertinentes de la Directive 1999/5/EC. Une copie de la déclaration de conformité est disponible sur demande. Contactez-nous à l'adresse [customercare@spinmaster.com](mailto:customercare@spinmaster.com) ou SPIN MASTER INTERNATIONAL S.A. R. L., 16 Avenue Pasteur, L-2310, Luxembourg.

**E.** Por la presente, Spin Master International SARL declara que este juguete Meccanoid G15™ cumple con los requisitos esenciales y con otras provisiones relevantes de la Directiva 1999/5/EC. Se puede solicitar una copia de la declaración de conformidad en [customercare@spinmaster.com](mailto:customercare@spinmaster.com) o en SPIN MASTER INTERNATIONAL S.A.R.L., 16 Avenue Pasteur, L-2310, Luxembourg.

**D.** Spin Master International SARL erklärt hiermit, dass Meccanoid G15™ den grundlegenden Anforderungen und weiteren Bestimmungen der Richtlinie 1999/5/EG entspricht. Ein Exemplar der Konformitätserklärung kann per E-Mail an [customercare@spinmaster.com](mailto:customercare@spinmaster.com) oder bei SPIN MASTER INTERNATIONAL S.A.R.L., 16 Avenue Pasteur, L-2310, Luxemburg, angefordert werden.

**NL.** Spin Master International SARL verklaart hierbij dat deze Meccanoid G15™ voldoet aan de noodzakelijke vereisten en andere voorwaarden in richtlijn 1999/5/EG. U kunt een kopie van deze conformiteitsverklaring opvragen via [customercare@spinmaster.com](mailto:customercare@spinmaster.com) of SPIN MASTER INTERNATIONAL S.A.R.L., 16 Avenue Pasteur, L-2310, Luxembourg.

**I.** Spin Master International SARL dichiara che questo Meccanoid G15™ è in regola con i requisiti essenziali e altre clausole rilevanti della Direttiva 1999/5/EC. Una copia della dichiarazione di conformità può essere richiesta scrivendo a [customercare@spinmaster.com](mailto:customercare@spinmaster.com) o SPIN MASTER INTERNATIONAL S.A.R.L., 16 Avenue Pasteur, L-2310, Lussemburgo.

**P.** A Spin Master International SARL declara por meio desta que o Meccanoid G15™ está em conformidade com as exigências essenciais e outras disposições relevantes da Diretiva 1999/5/EC. Uma cópia da declaração de conformidade pode ser solicitada pelo e-mail [customercare@spinmaster.com](mailto:customercare@spinmaster.com) ou via missiva endereçada à SPIN MASTER INTERNATIONAL S.A.R.L., 16 Avenue Pasteur, L-2310, Luxembourg.

**R.** Компания Spin Master International SARL настоящим заявляет, что данное устройство Meccanoid G15™ соответствует основным требованиям и другим релевантным положениям Директивы 1999/5/EC. Копию декларации соответствия можно получить, отправив запрос на адрес [customercare@spinmaster.com](mailto:customercare@spinmaster.com) или обратившись по адресу SPIN MASTER INTERNATIONAL S.A.R.L., 16 Avenue Pasteur, L-2310, Luxembourg.



UK – 0800 204 1191, se rv ic eu k @ sp in mast er .com  
 FRANCE – 0800 909 150, se rv ic ef r @ sp in mast er .com  
 ESPAÑA – se rv ic io @ spinmas te r .co m  
 DEUTSCHLAND – 0800 0101 0222, Kund en se rv ic e @ sp in mast er .com  
 SCHWEIZ – 0800 561 350 • ÖSTERREICH – 0800 29 72 67  
 Nederland – 0800 022 36 83, kl an te ns er vice @ spinmas te r .co m  
 BELGIË/BELGIQUE – 0800 77 688 • LUXEMBOURG – 800 28 044  
 ITALIA – 800 788 532, se rv izio @ spinmas te r .co m  
 MEXICO – (55) 5351-4400

**NORTH AMERICA • AMÉRIQUE DU NORD**  
 1-800-622-8339, [CUSTOMERCARE@spinmaster.com](mailto:CUSTOMERCARE@spinmaster.com)

Bluetooth operates at: 2.4GHz  
 Fréquence de fonctionnement du Bluetooth : 2,4 GHz  
 La conexión Bluetooth funciona a: 2,4 GHz  
 Bluetooth arbeitet mit einer Frequenz von: 2,4 GHz  
 Bluetooth werkt op een frequentie van: 2,4 GHz  
 Bluetooth funziona a: 2,4 GHz  
 Bluetooth opera a: 2,4 GHz  
 Сигнал Bluetooth действует на частоте: 2,4 GHz

TM & © 2015 MECCANO for packaging, instructions and models built with this set. © MECCANO is an exclusive trademark of MECCANO. Spin Master logo is a trademark of Spin Master Ltd. All rights reserved. Patent pending.

TM & © 2015 MECCANO pour l'emballage, les notices et modèles de ce coffret. © MECCANO est une marque de commerce exclusive de MECCANO. Le logo de Spin Master est une marque de commerce de Spin Master Ltd. Tous droits réservés. Brevet en instance.

SPIN MASTER LTD., 450 FRONT STREET WEST, TORONTO, ON M5V 1B6 CANADA.

Imported into EU by  
 Spin Master International, S.A.R.L., 16 Avenue Pasteur . L-2310, Luxembourg.  
[www.spinmaster.com](http://www.spinmaster.com)

Spin Master Inc., PMB #10053, 300 International Drive, Suite 100, Williamsville, NY 14221

MADE IN CHINA / FABRIQUÉ EN CHINE / HECHO EN CHINA

T91763\_0002\_20068865\_GML\_IB\_R5\_MEC\_Meccnoid G15\_CN



Meets CPSC safety standards / Conforme aux exigences de sécurité de la CPSC.  
 Cumple con las normas de seguridad de la CPSC.