



⑩ Merci d'imprimer à échelle 1 sans les marges de l'imprimante.
⑩ Please print at scale 1 without the printer margins.
⑩ Den Maßstab 1 bitte randlos drucken.
⑩ Stampare la scala 1 senza i margini della stampante.
⑩ Imprimir a escala 1 sin los márgenes de la impresora.
⑩ É favor imprimir escala 1 sem as margens da impressora.
⑩ Skriv ut i skala 1 utan skrivarens marginaler.
⑩ Portaiden painatuksen jälkeen reunat eivät saa näkyä.
⑩ Udskriv venligst i målestoksforhold 1 uden printermarginer.
⑩ É favor imprimir escala 1 sem as margens da impressora.
⑩ Σας παρακαλώ τυπώστε την κλίμακα 1 μόνο στα περιθώρια του εκτυπωτή.
⑩ Пожалуйста, печатайте в масштабе 1:1 без отступов от края.

EVOLUTION

10+

8210

Instructions

Notice de montage

Bauanleitung

Istruzioni di montaggio

Instrucciones de montaje

Instruções de montagem

Monteringsanvisning

Kokoamisohje

Monterings instruktioner

Montagehandleiding

Οδηγίες συναρμολόγησης.

Инструкция

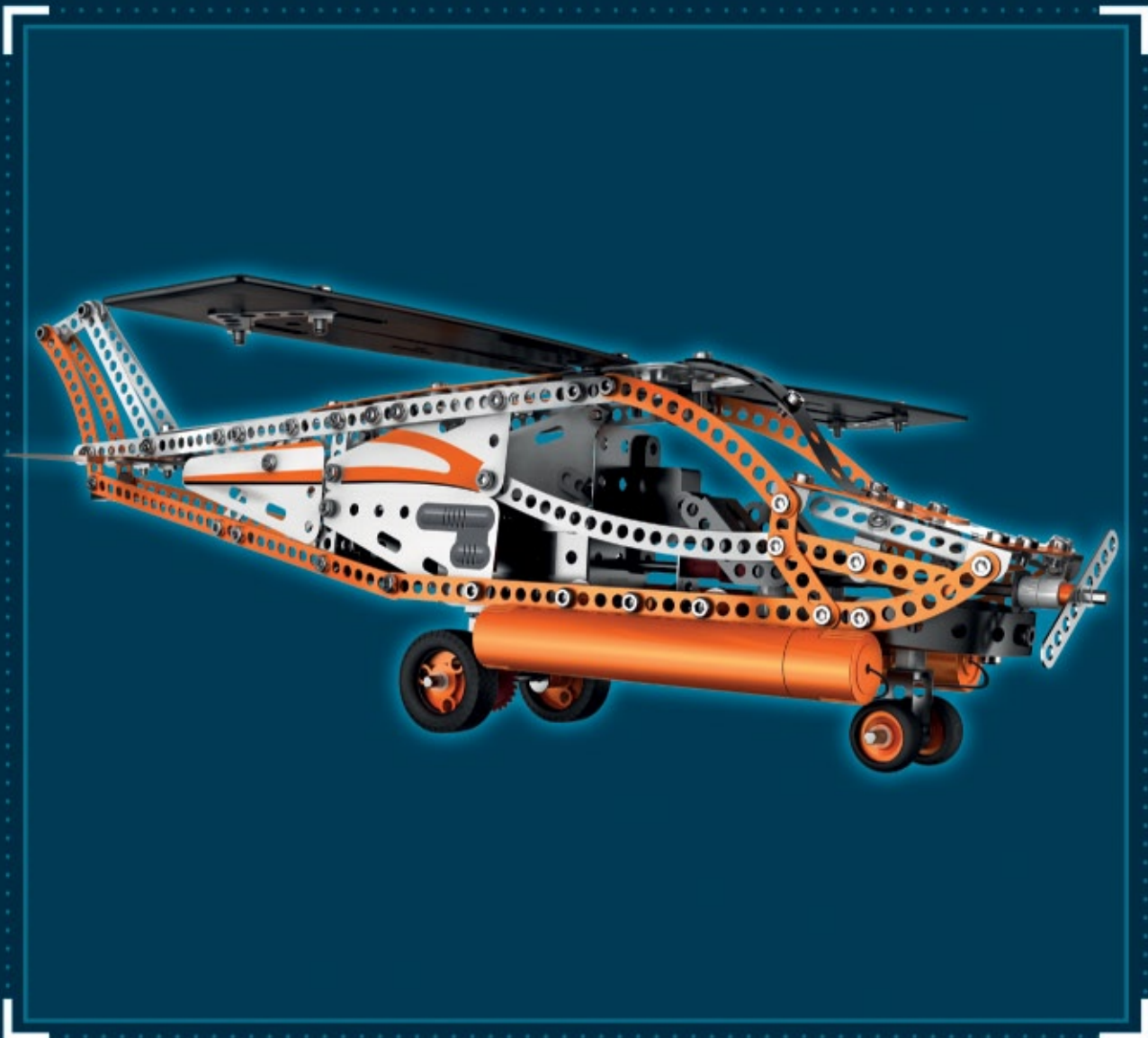



CONSTRUCTION TIPS

LES ASTUCES DE CONSTRUCTION
 KONSTRUKTIONS-TIPPS
 LE ASTUZIE DELLA COSTRUZIONE
 LOS INGENIOS DE LA CONSTRUCCIÓN
 DICAS PARA A MONTAGEM
 KOKOONPANON KIKAT
 BYGGKNEPEN
 ET PAR TIPS TIL BYGGEARBEJDET
 DE FIJNE KNEEPJES VAN HET BOUWEN
 Τα έξυπνα κόλπα κατασκευής
 рекомендации по сборке

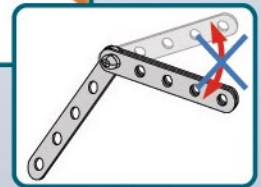
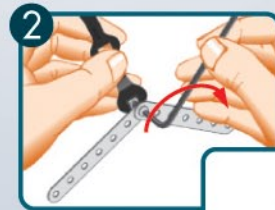
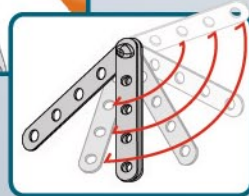
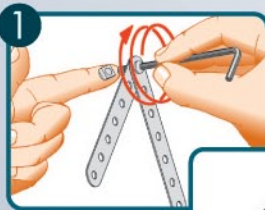
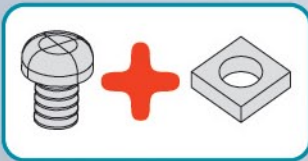
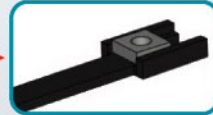
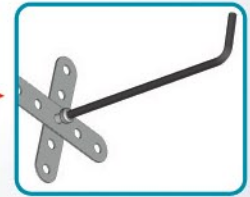
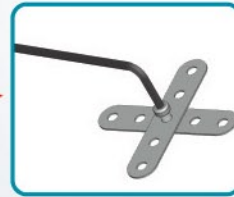

A128 (0028P3P) x 1



B222 x3



A322 (0022CP3P) x2



A631 (0025D3P) x1



C881 x1



A523 (0023BP3P) x2



A523 (0023BP3P) x2



A342 (0142K) x2



A384 (0142J) x2



A195 (0057B) x1



S6

28mm
1 1/8"

A611 (0111D) x1



S6

28mm
1 1/8"

A611 (0111D) x1



S5

25,4mm
1"

A912 (0111E) x2



S4

19mm
3/4"

A911 (0111) x2



S4

19mm
3/4"

A911 (0111) x4



B1

14,7mm
37/64"

A247 (0147D) x1



S3

12mm
1/2"

A411 (0111A) x8



S2

9,5mm
3/8"

A511 (0111C) x11



S1

5,8mm
15/64"

A637 (0037B) x23



S1

5,8mm
15/64"

A637 (0037B) x127



A313 (0213D3P) x1



A623 (0023C3P) x1



C867 x6



A238 (0038A) x11



A238 (0038A) x21



A238 (0038A) x12



A338 (0038B) x9



A338 (0038B) x5



A259 (0059C) x13



A337 (0037A) x26



A337 (0037A) x154



A138 (0038) x17



A136 (0036C) x1



C088 x1



C976 x1



C975 x1



A751 (0051E) x2



C887 x2

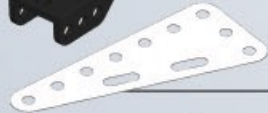

A224 (0224) x6



A221 (0221) x2



A520 (0188) x2



A300 (0103F) x2



A174 (0074) x2



A163 (0163) x1



B695 x1



C004 x1



C897 x1



A420 (0260C) x3



C587 x4



C903 x4



C898 x1



A898 (0040B) x1



C900 x4



115mm | 4 1/2" | **A427 (0315A) x2**



90mm | 3 1/2" | **A316 (0316) x2**



75mm | 3" | **A429 (0316B) x1**



60mm | 2 3/8" | **A516 (0316A) x2**



50mm | 2" | **A317 (0317) x1**



40mm | 1 9/16" | **A318 (0318A) x1**



A189 (0089) x2



C780 x2



C779 x4



C779 x2

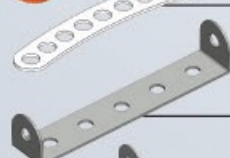

A448 (0048A) x2

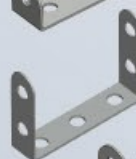

A846 (0846A) x1



A248 (0048) x3

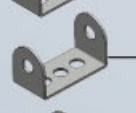

A548 (0048E) x2



A720 (0011) x2



A811 (0811) x1



A512 (0012B) x3



A721 (0011A) x1

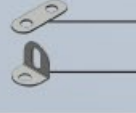

A436 (0811A) x1

C331 x2

C483 x3

A806 (0806B) x2

A012 (0012) x4



C774 x2



C774 x10



C774 x6



A202 (0002) x1



A302 (0002A) x2



C773 x4



C773 x2



B482 x1



B488 x1



B973 x2



A414 (0235B) x2



C771 x7



C771 x4



C771 x2



C771 x2



C771 x4



C947 x2



C769 x1



A105 (0005) x2

C768 x1

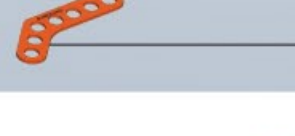

C776 x4



C775 x4

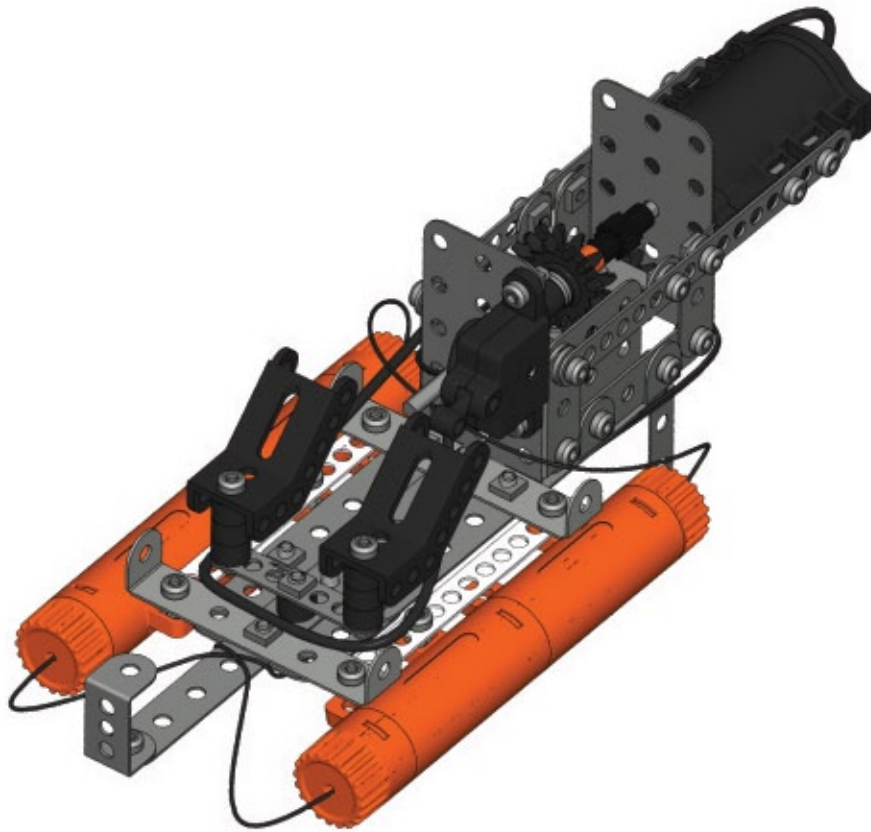



1

A202 (00021) X 1

A448 (04481) X 1

5,8mm | A637 (00370) X 1
15/64"

A337 (00370) X 1

	S1	1:1	
	Scale 1	Escala 1	Mittakaava 1
	Echelle 1	Schaal 1	Målestok 1
	Maßstab 1	Escala 1	Κλίμακα 1
	Scala 1	Skala 1	масштаб 1

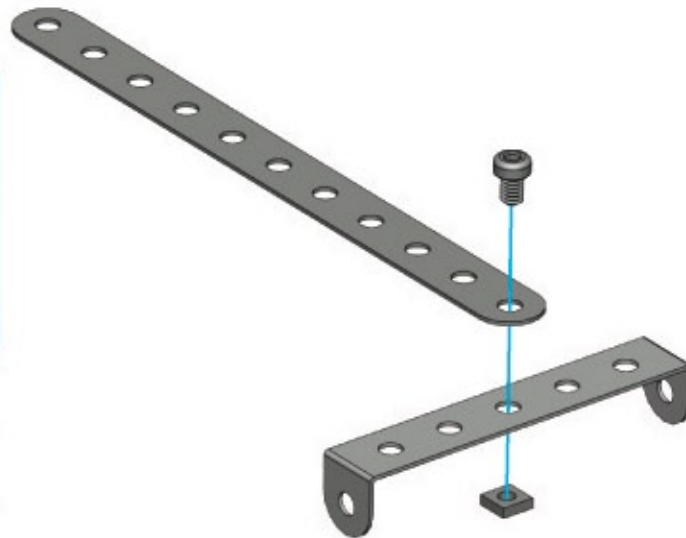

2

A302 (00020) X 1

5,8mm | A637 (00370) X 1
15/64"

A337 (00370) X 1

	S1	1:1
---	----	-----

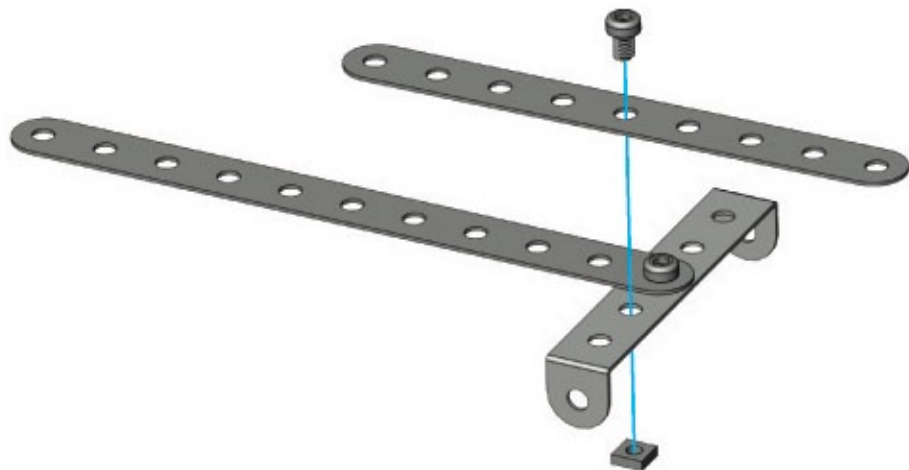

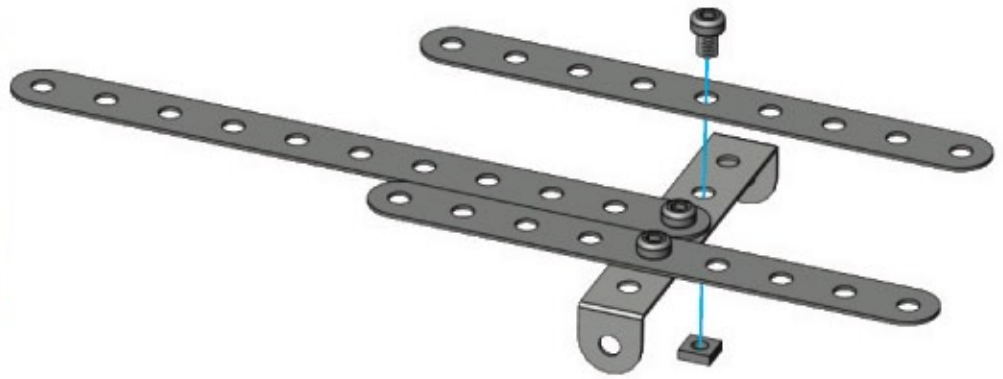
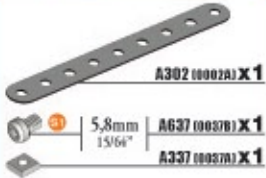
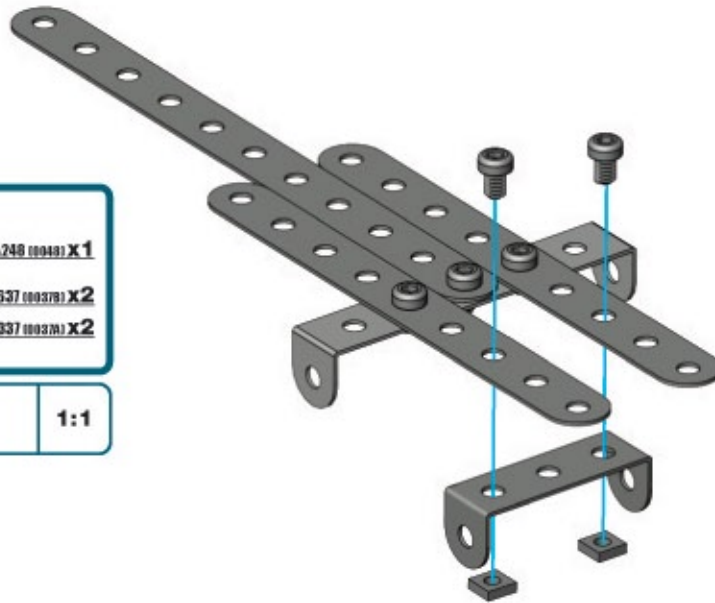
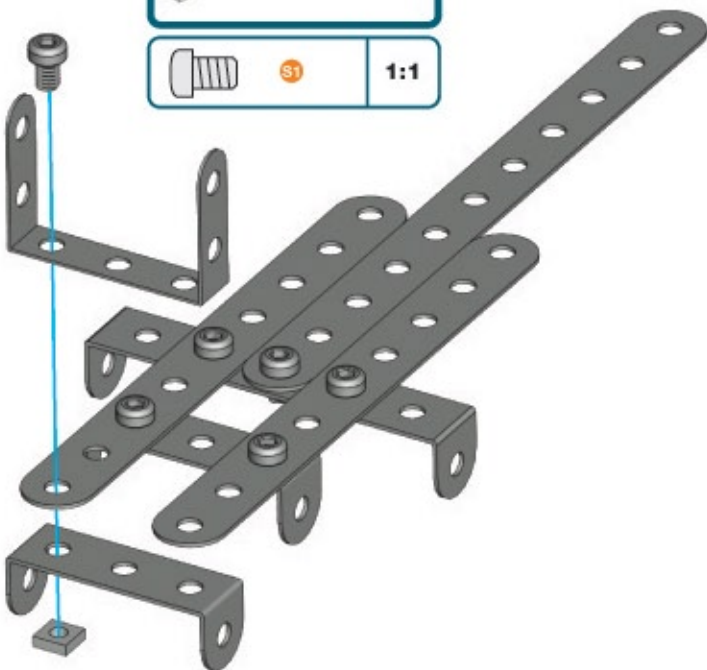
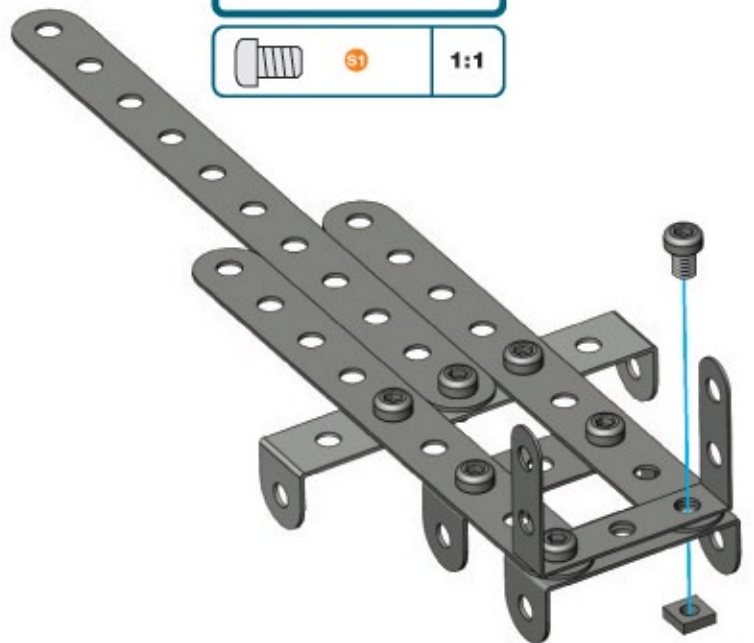
3**4****5****6**

7

A105 (10095) X 1

5,8mm 15/64" A637 (100370) X 2

A337 (100336) X 2

1:1

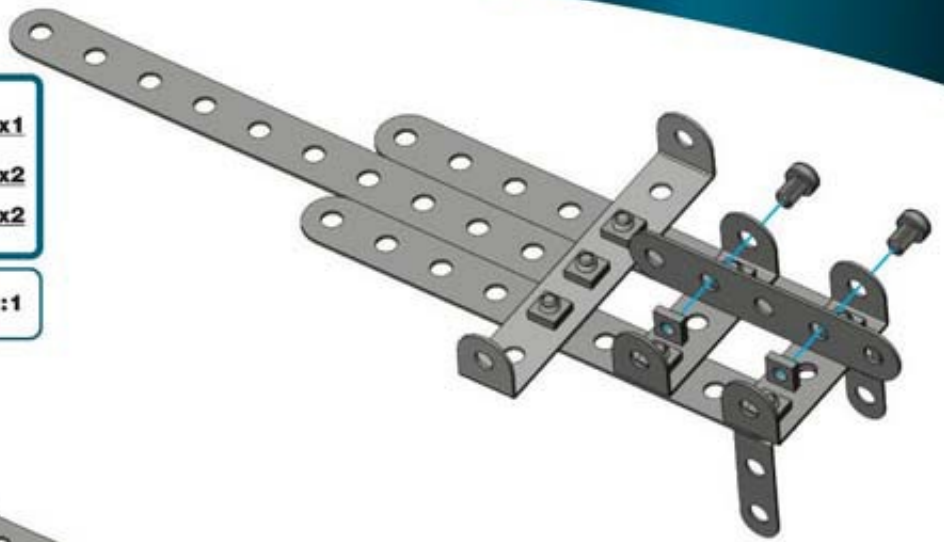

8

A105 (10095) X 1

5,8mm 15/64" A637 (100370) X 1

A337 (100336) X 1

1:1

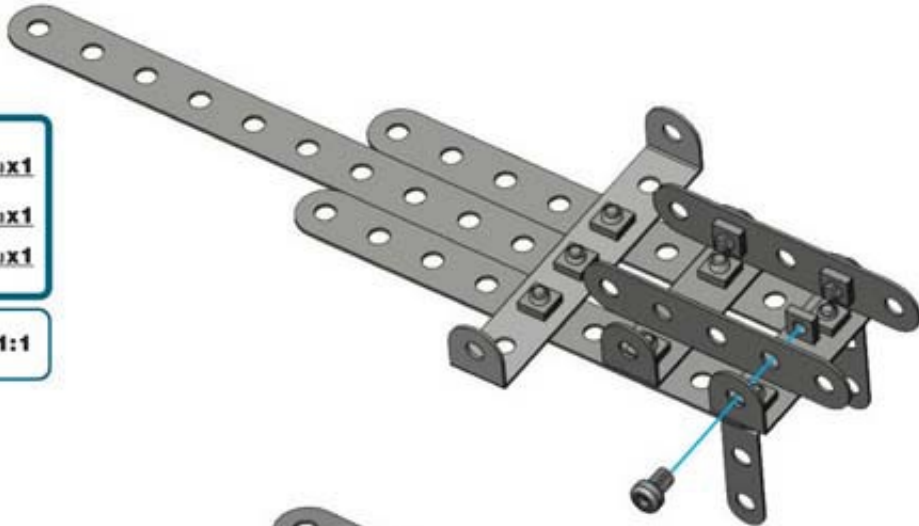

9

A174 (10024) X 1

5,8mm 15/64" A637 (100370) X 1

A337 (100336) X 1

1:1

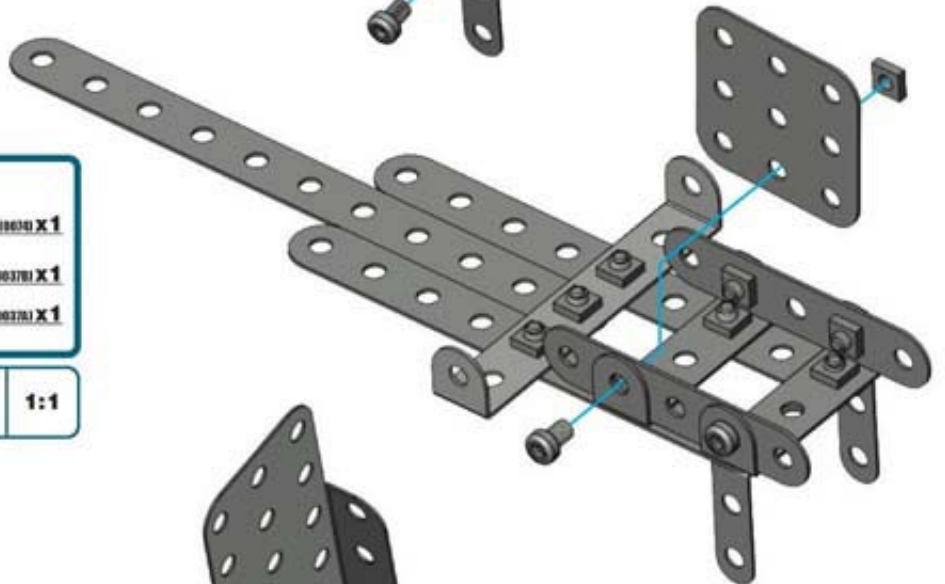

10

A751 (10051) X 1

5,8mm 15/64" A637 (100370) X 1

A337 (100336) X 1

1:1

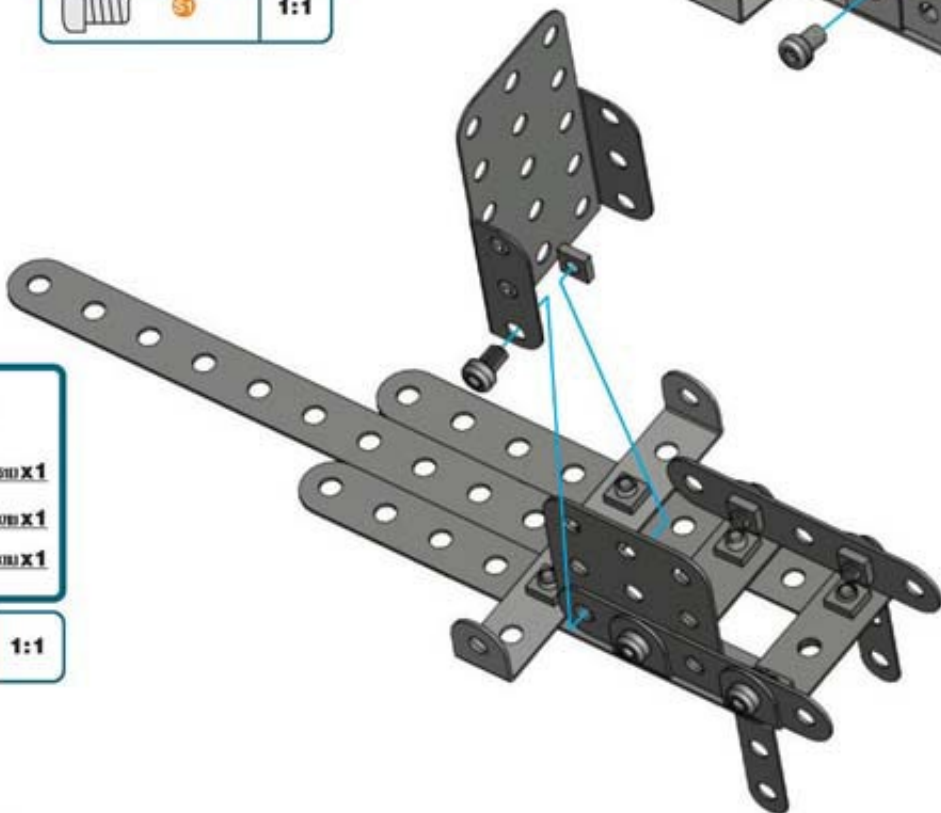

11

 5,8mm | A637 (000270) X 1
15/64"
 A337 (000270) X 1

 53 | 1:1

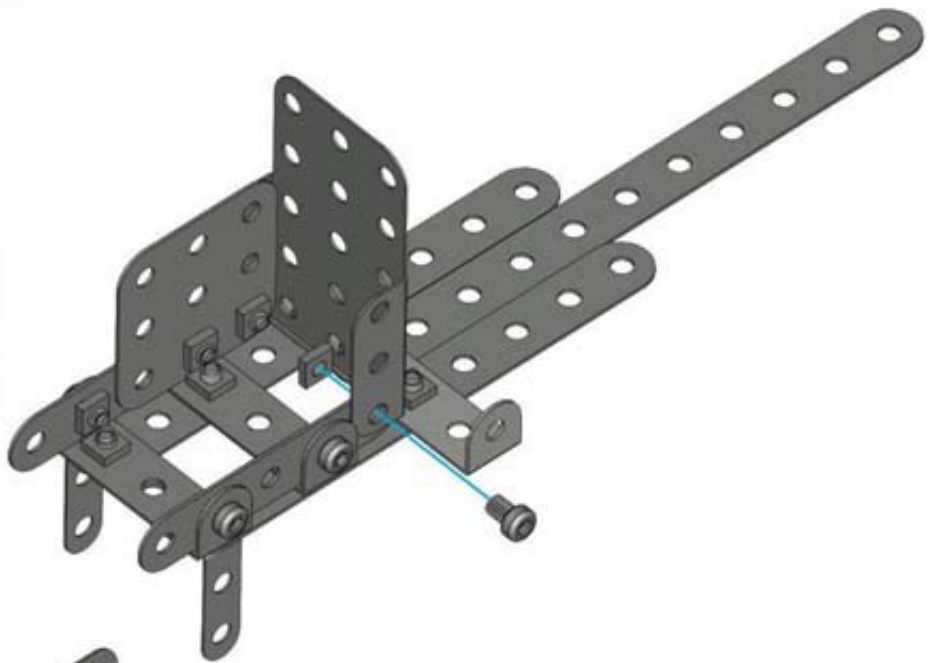

12

 A751 (000591) X 1
 5,8mm | A637 (000270) X 1
15/64"
 A337 (000270) X 1

 53 | 1:1

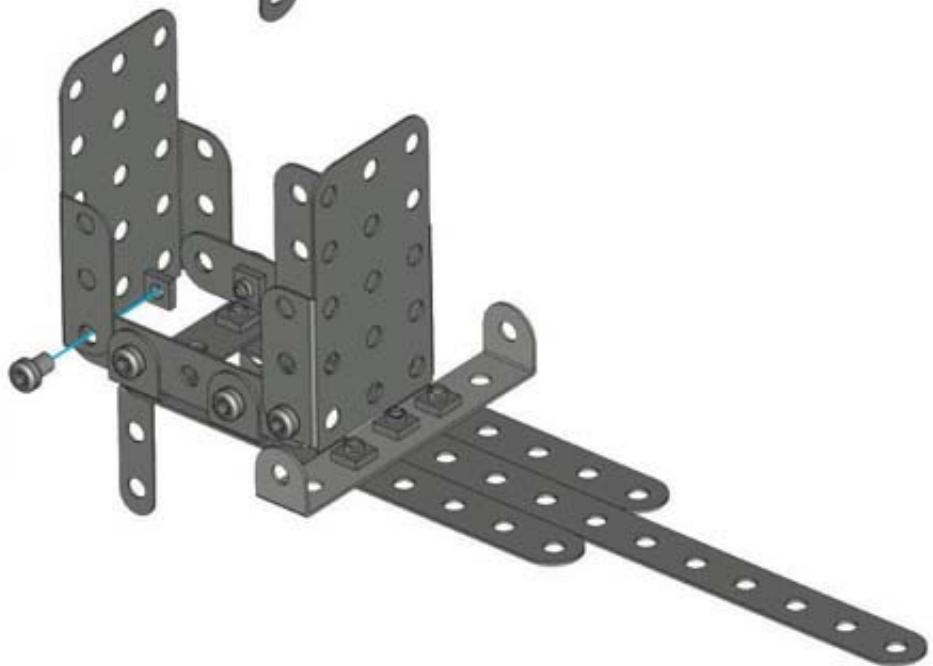

13

 5,8mm | A637 (000270) X 1
15/64"
 A337 (000270) X 1

 53 | 1:1

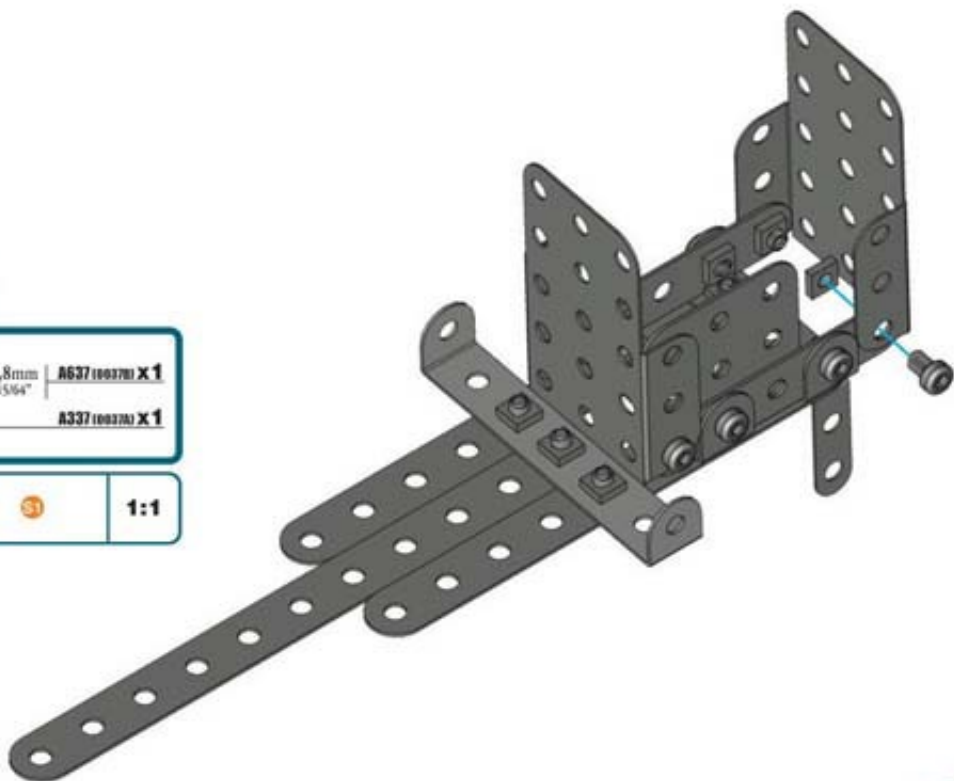

14

A138 (0029) X 1

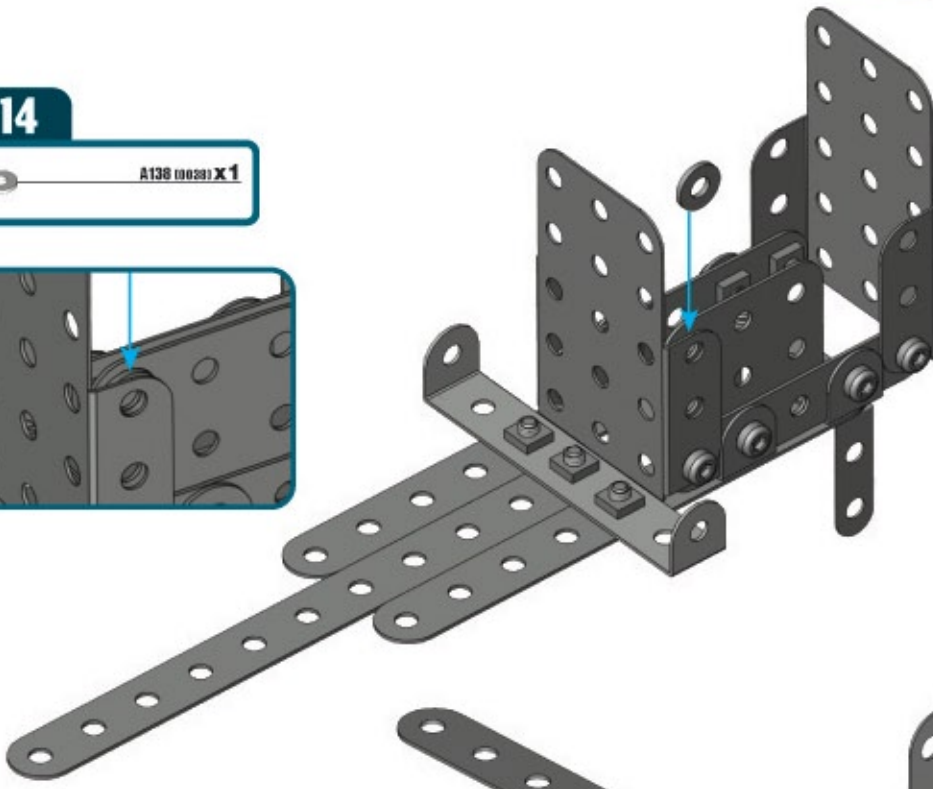
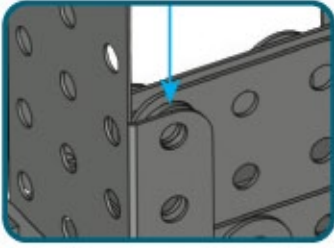

15

C714 X 1

A511 (01110) X 1
A337 (00370) X 1
A138 (0029) X 1

S2 1:1

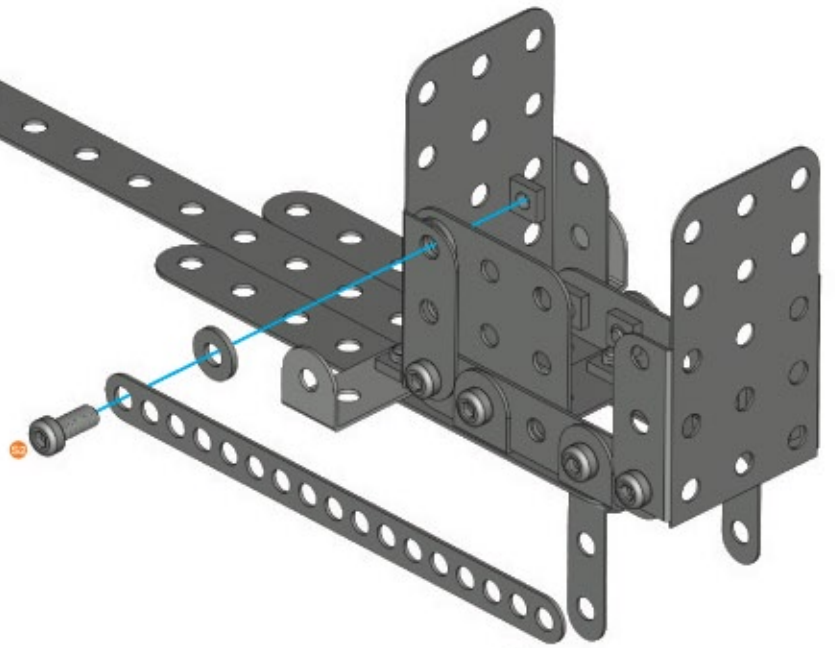

16

A637 (00378) X 1
A337 (00370) X 1
A138 (0029) X 1

S1 1:1

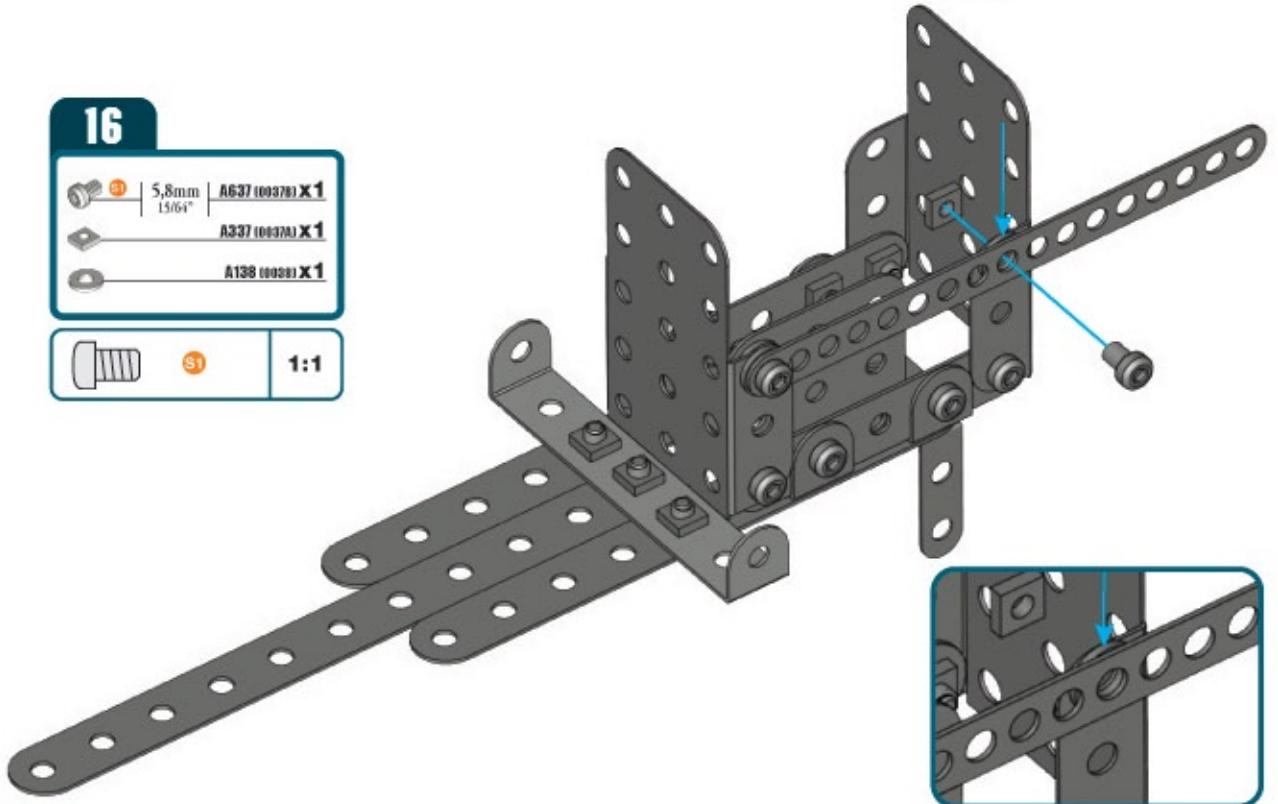

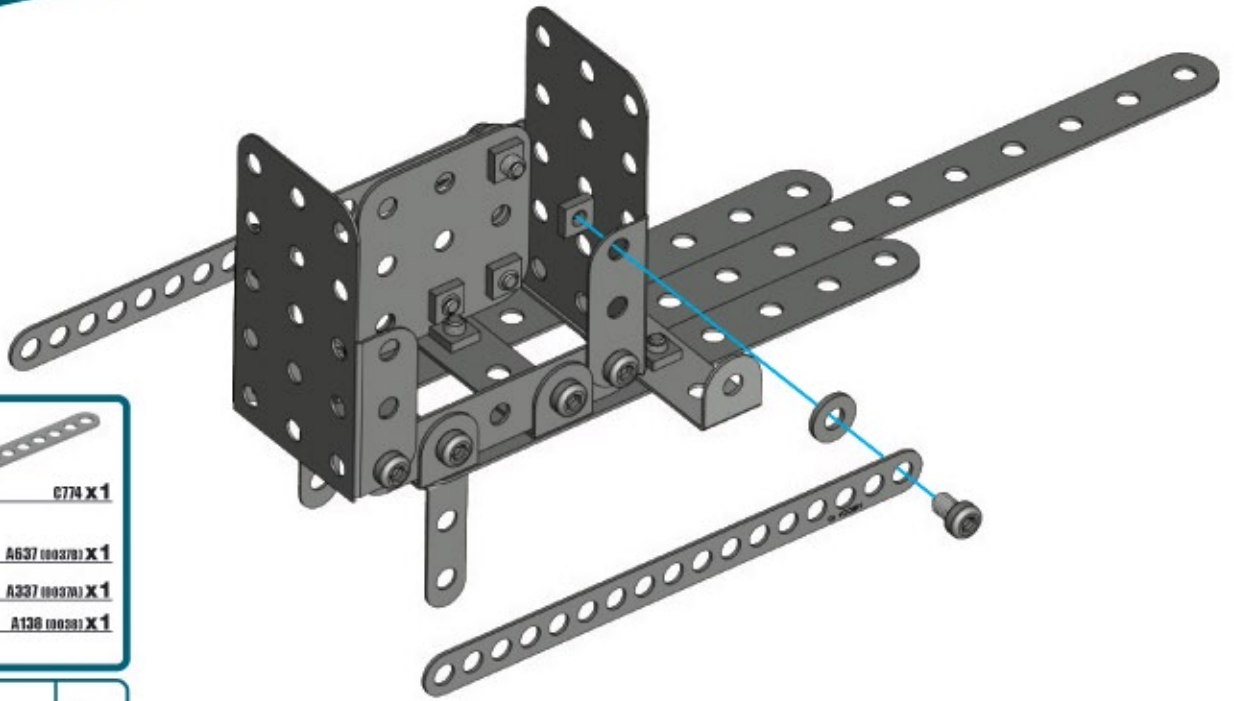
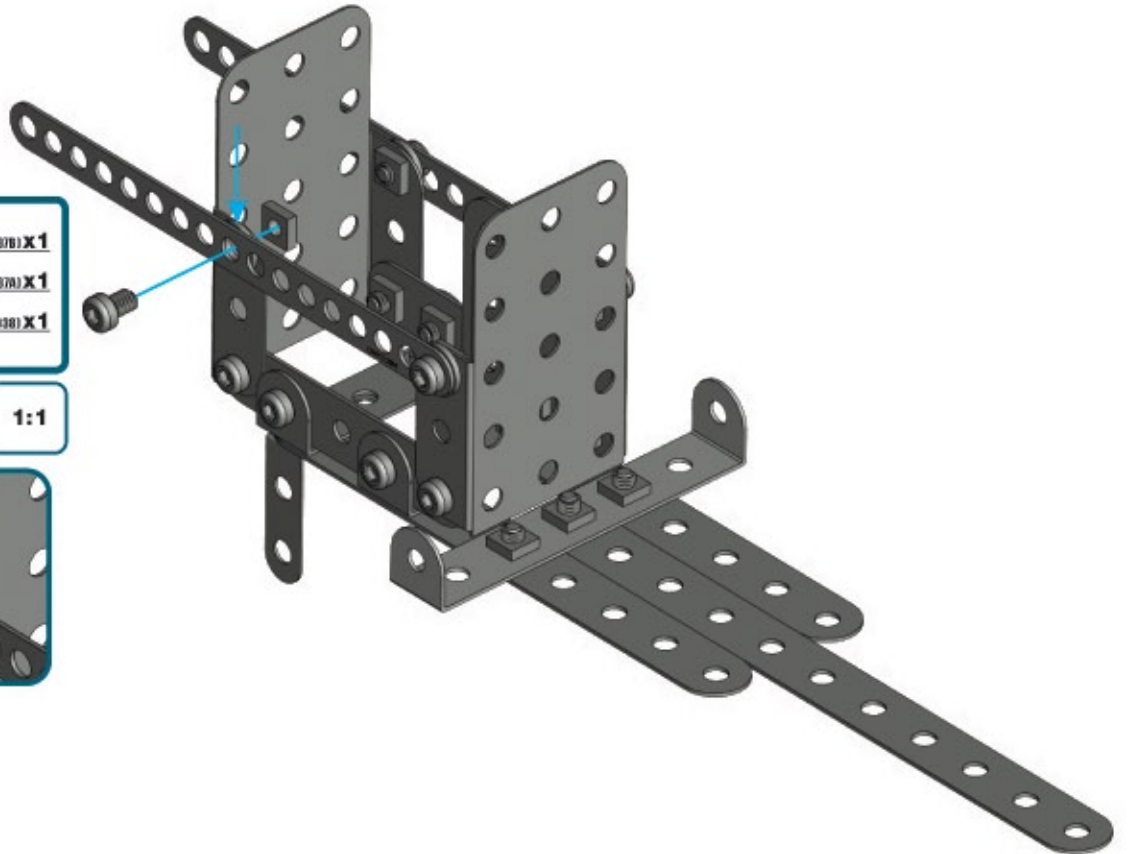
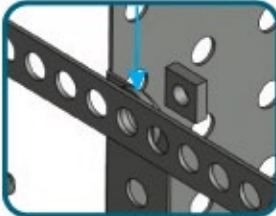
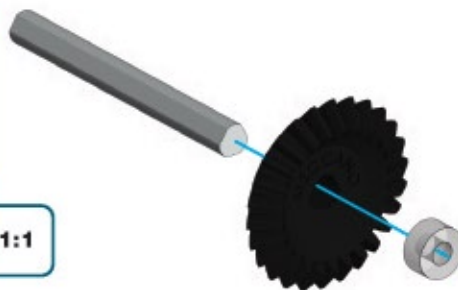
17**C774 X1****5,8mm X1****A637 (00270) X1****A337 (00270) X1****A138 (00280) X1****S1****1:1****18****5,8mm X1****A637 (00270) X1****A337 (00270) X1****A138 (00280) X1****S1****1:1****19****40mm X1****A318 (03180) X1****C903 X1****A259 (00590) X1****1:1**

20

(18) + (19) +

- B222 x 1
- C867 x 1
- A238 (0038A) x 1
- A338 (0038B) x 1

- A238
 - A338
- 1:1

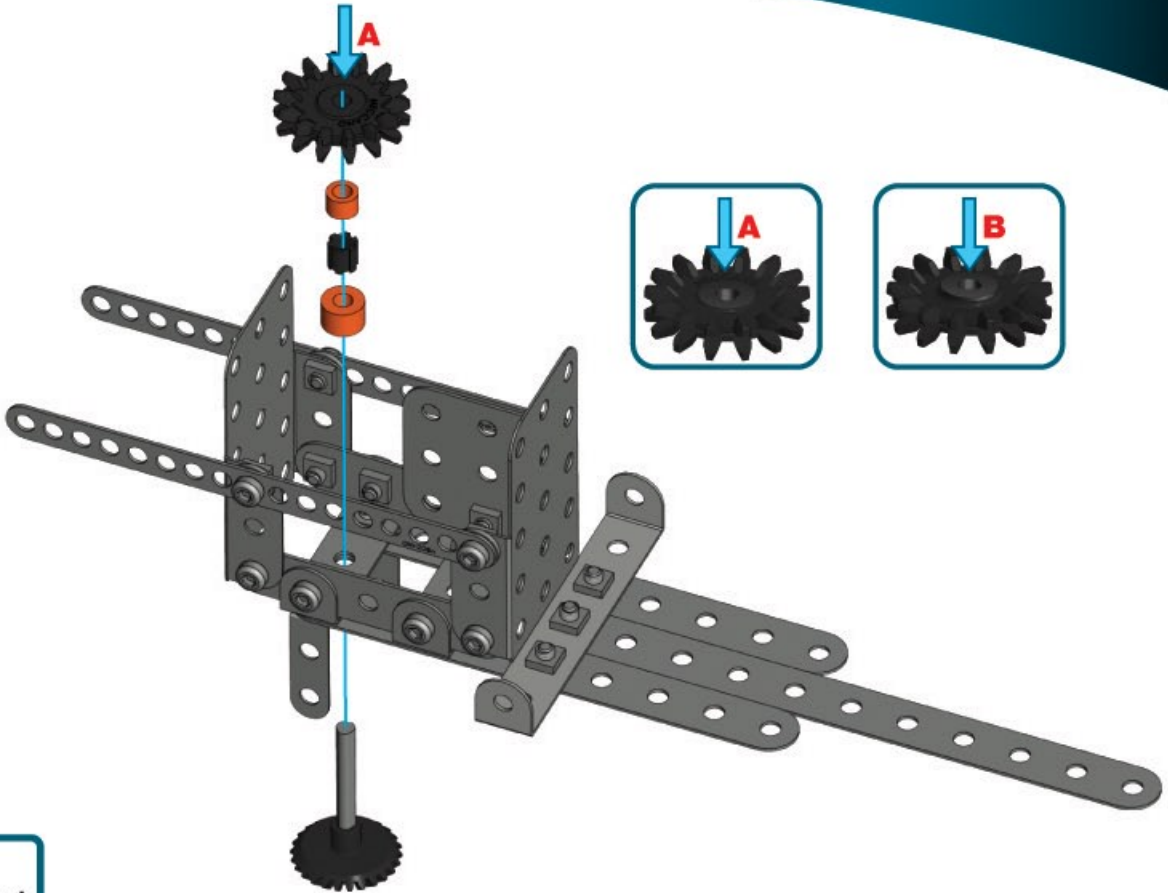

21

- A248 (0048) x 1
- A637 (0037B) x 1
- A337 (0037A) x 1
- A138 (0038) x 1

- S1
- 1:1

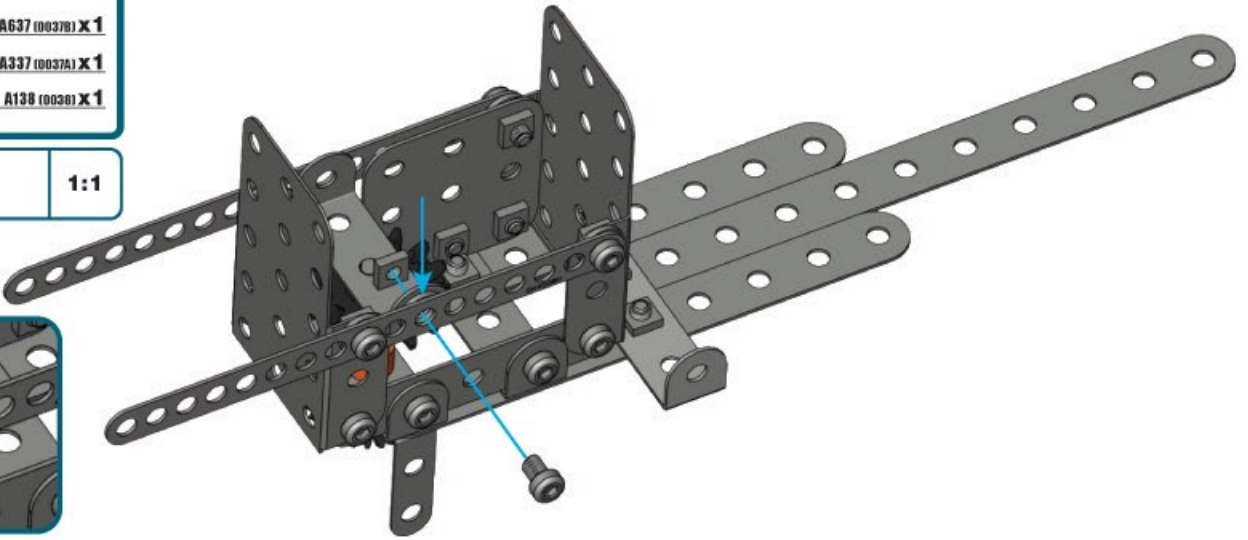
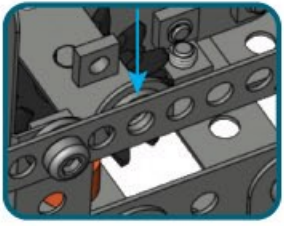

22

- A637 (0037B) x 1
- A337 (0037A) x 1
- A138 (0038) x 1

- S1
- 1:1

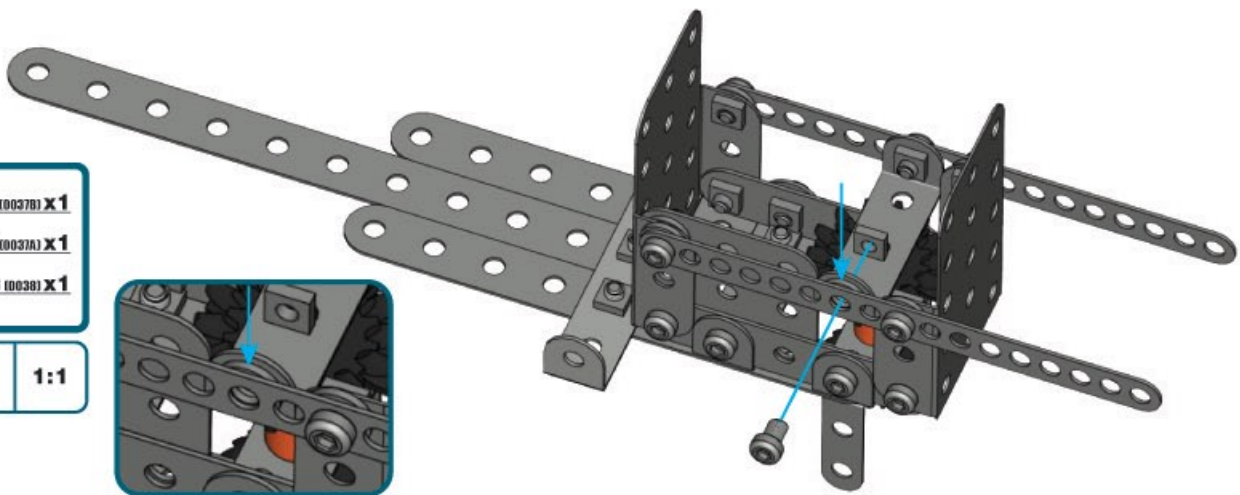
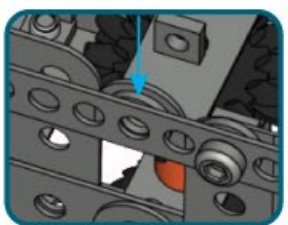

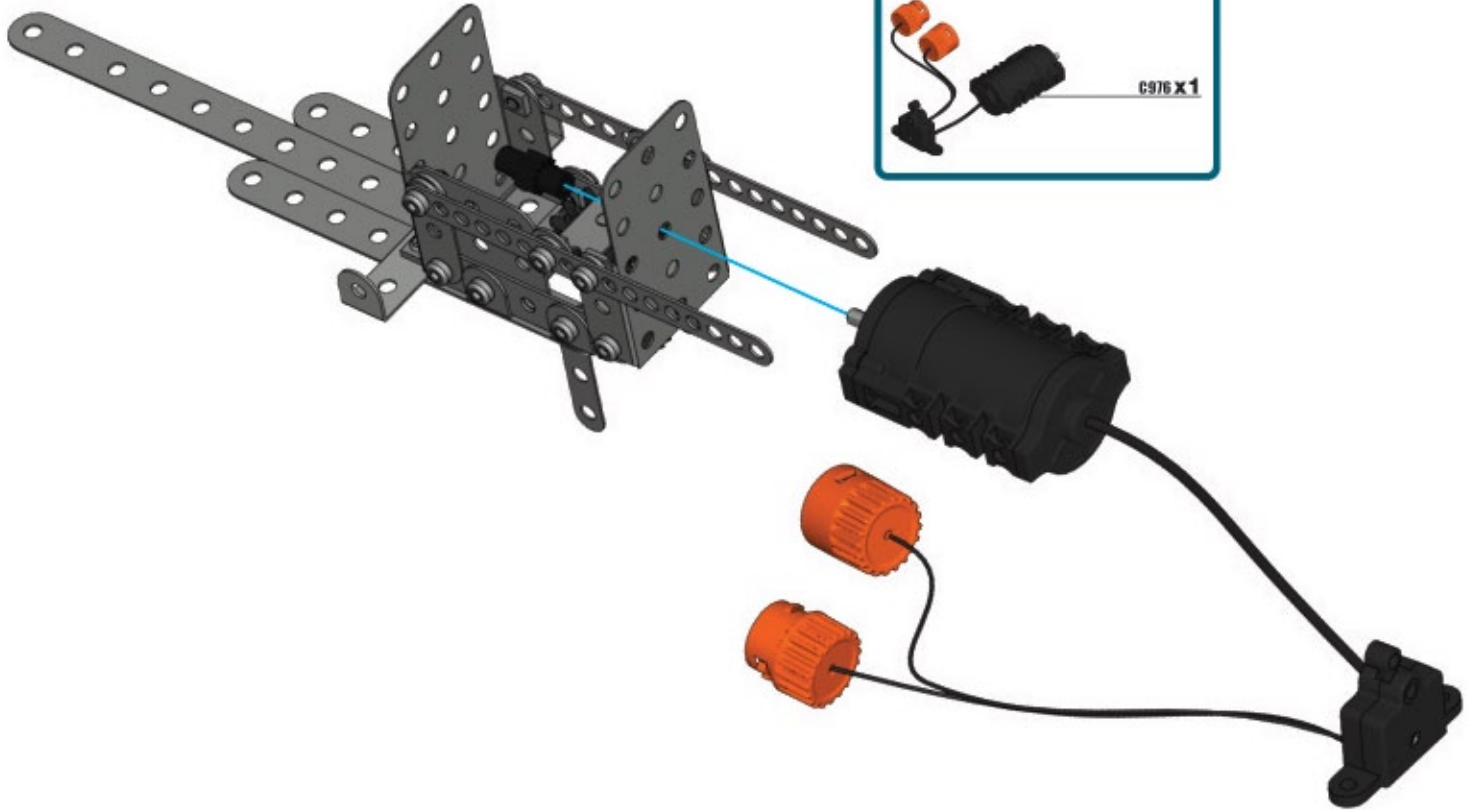

23

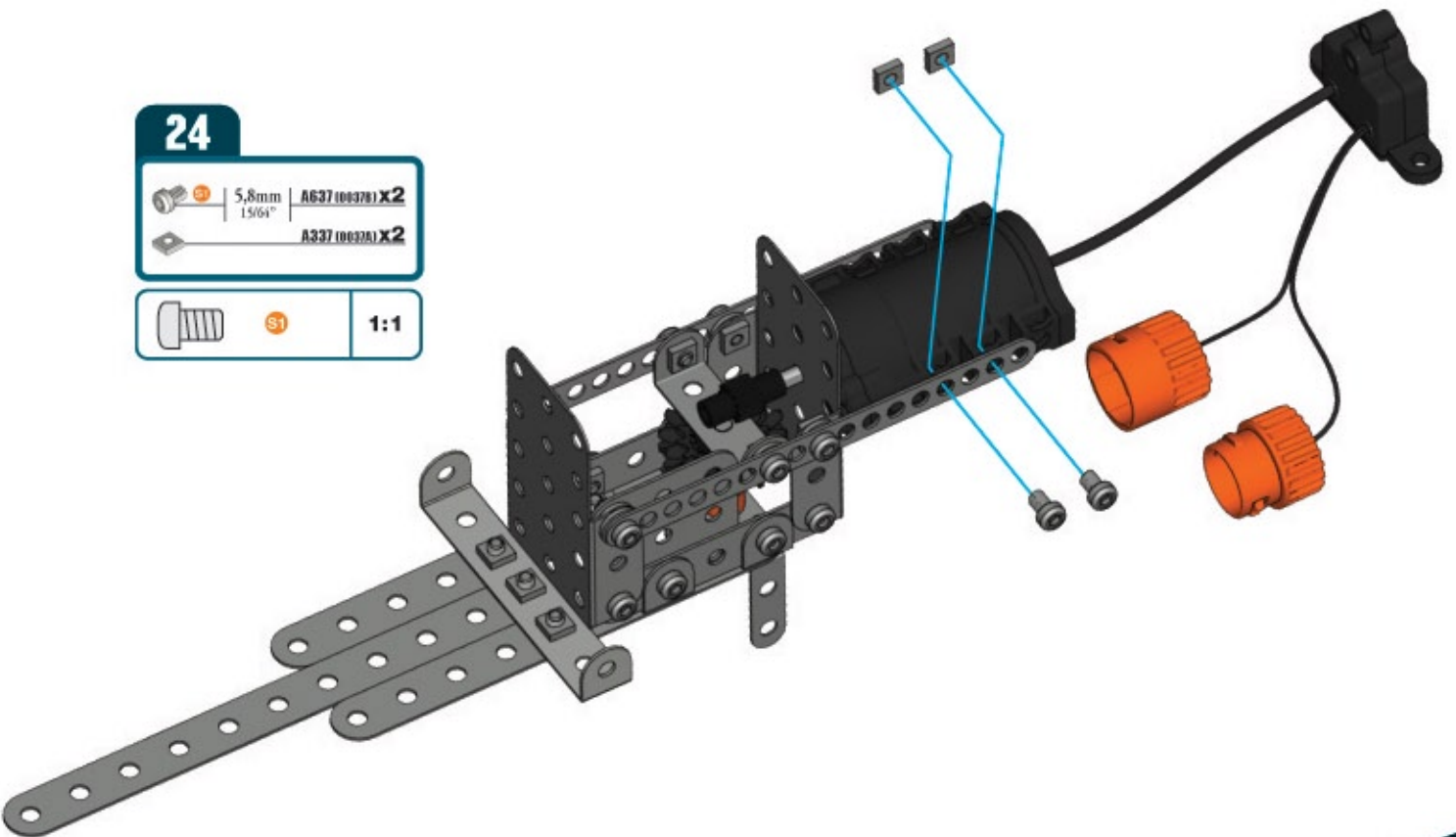

24



25

 5,8mm
 15/64" | **A637 (00378) X2**
 | **A337 (00378) X2**

 **1:1**

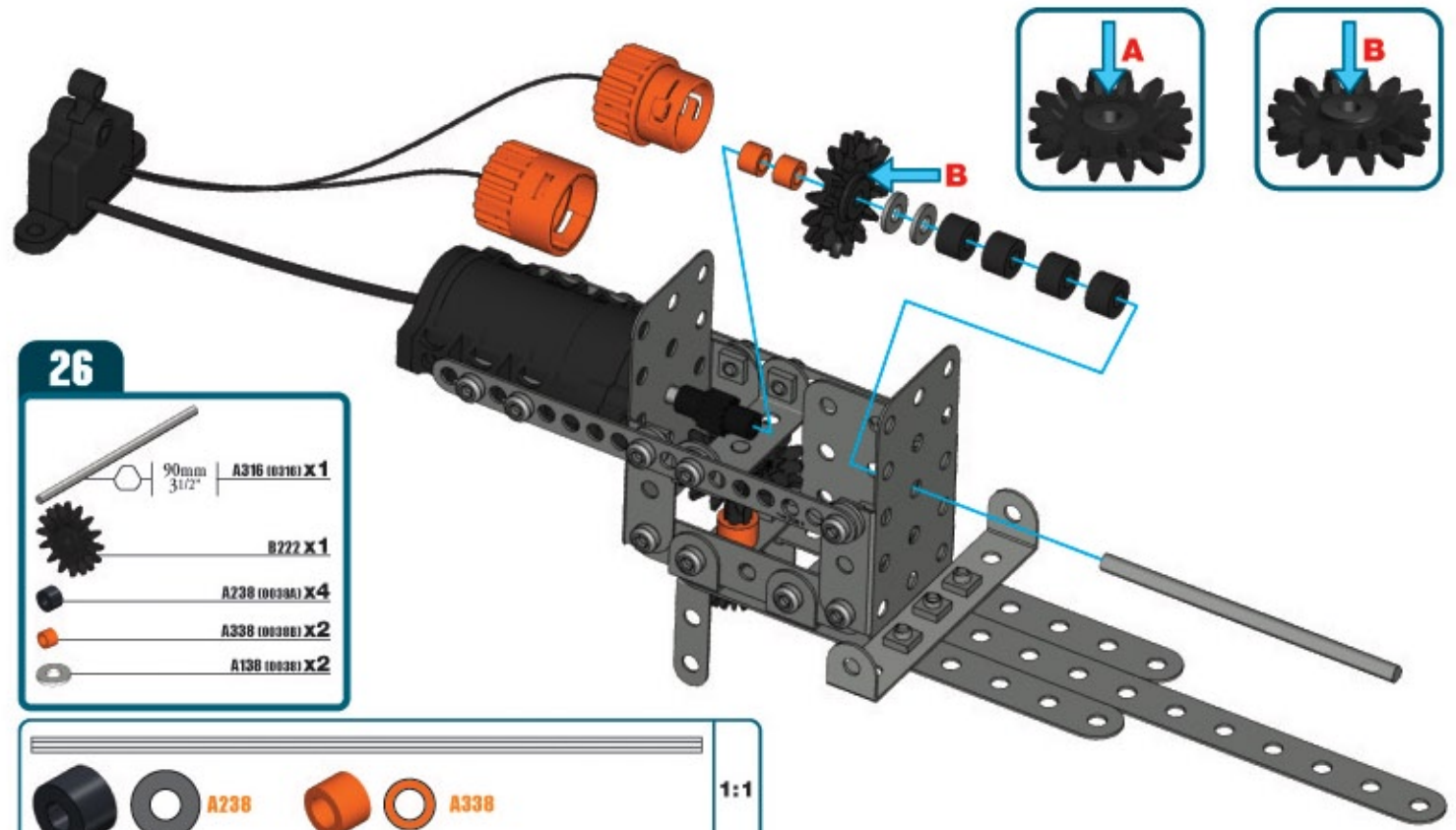
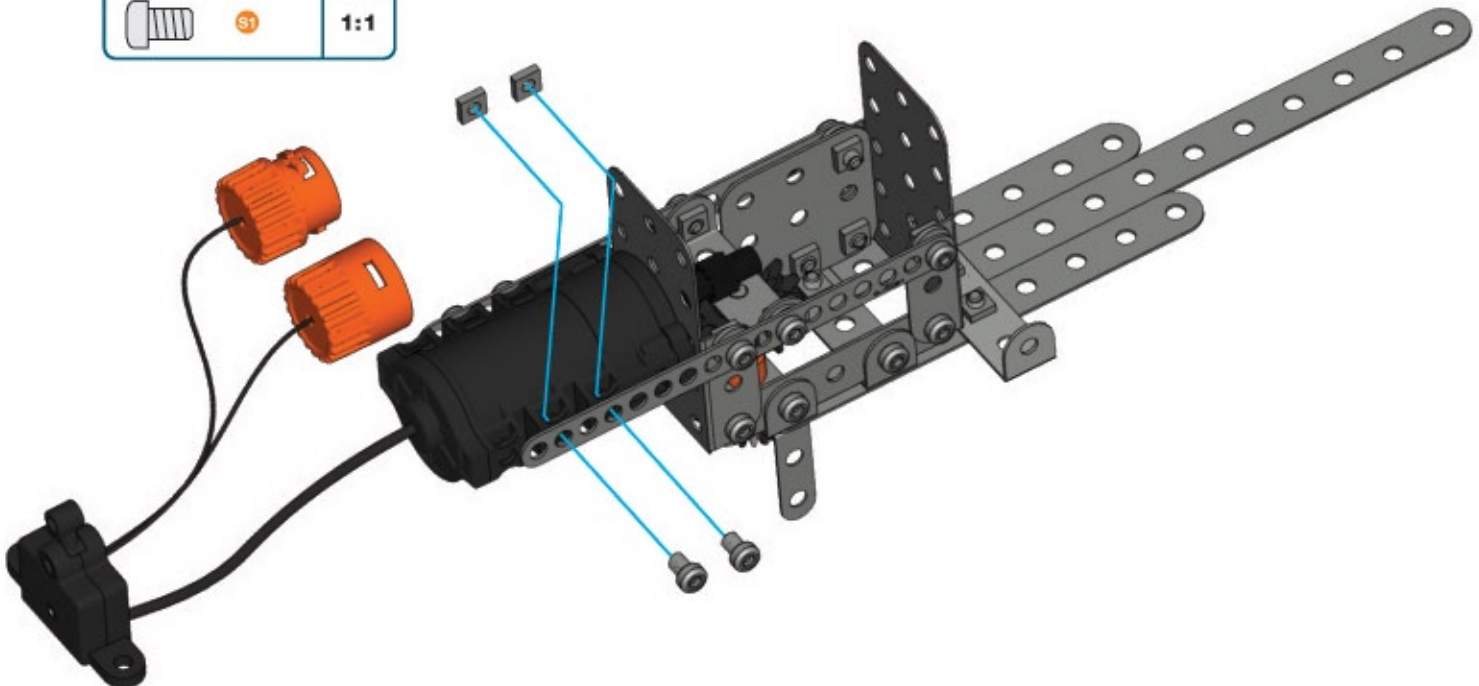

26

 90mm
 3 1/2" | **A316 (00316) X1**
 | **B222 X1**
 | **A238 (0038A) X4**
 | **A338 (0038B) X2**
 | **A138 (0038) X2**

 **A238**  **A338** **1:1**



27

	A174 (00274) X 1
	A637 (00378) X 1
	A337 (00270) X 1

	S1	1:1
--	----	-----

28

	A448 (04481) X 1
	A637 (00378) X 1
	A337 (00270) X 1

	S1	1:1
--	----	-----

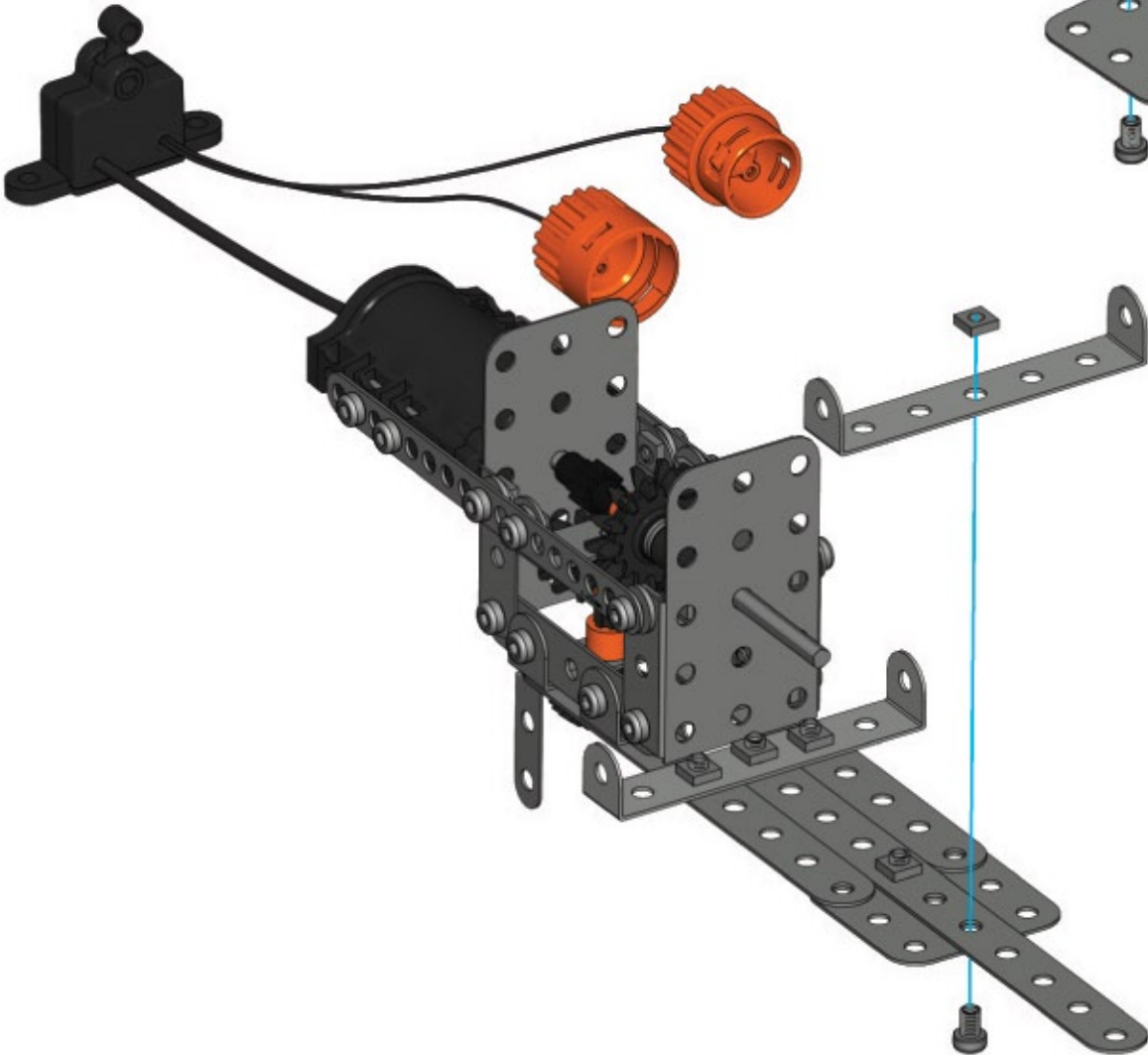

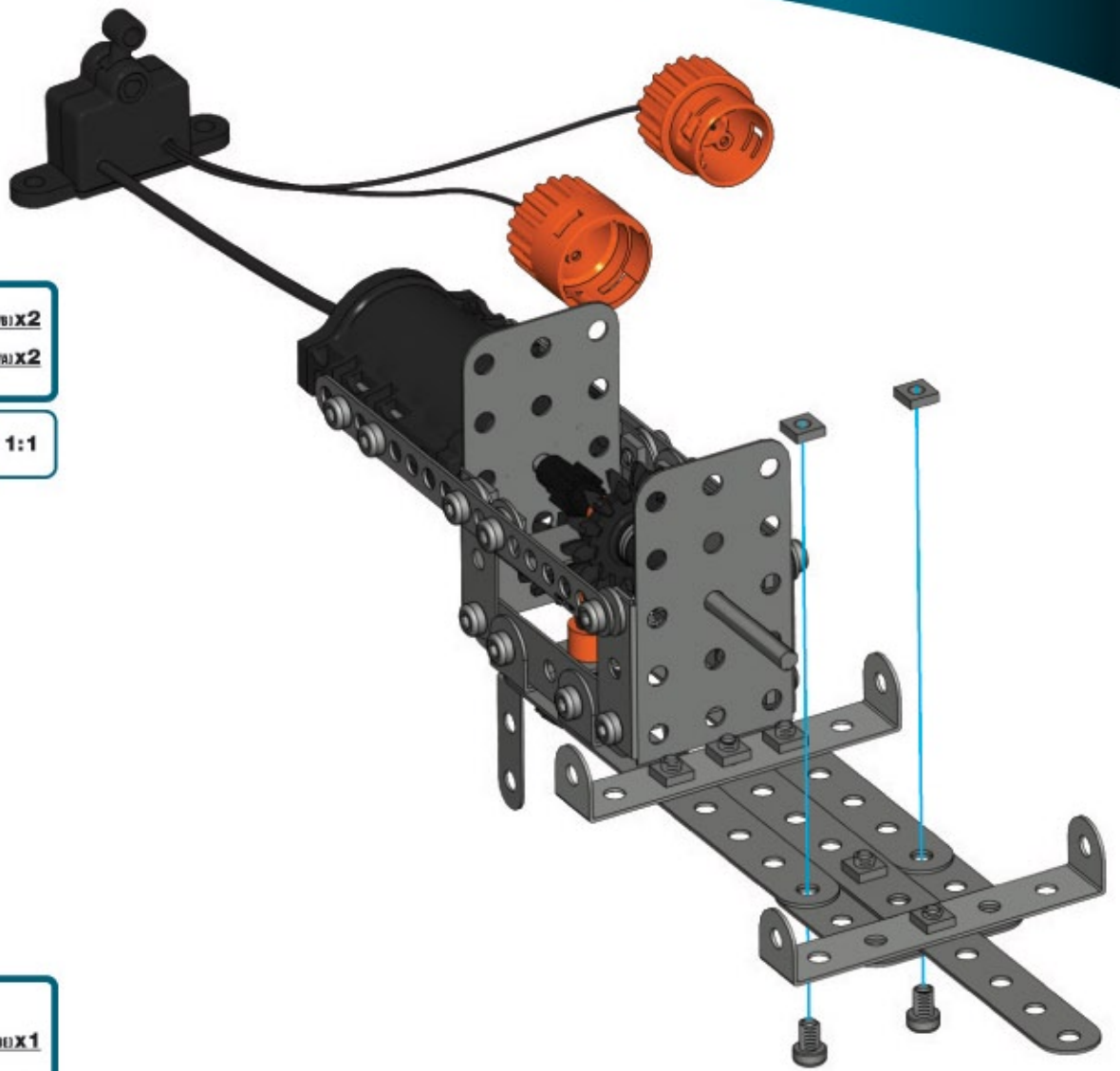

29

	5,8mm 15/64"	A637 (00370) X2
		A337 (00370) X2

	S1	1:1
---	-----------	------------

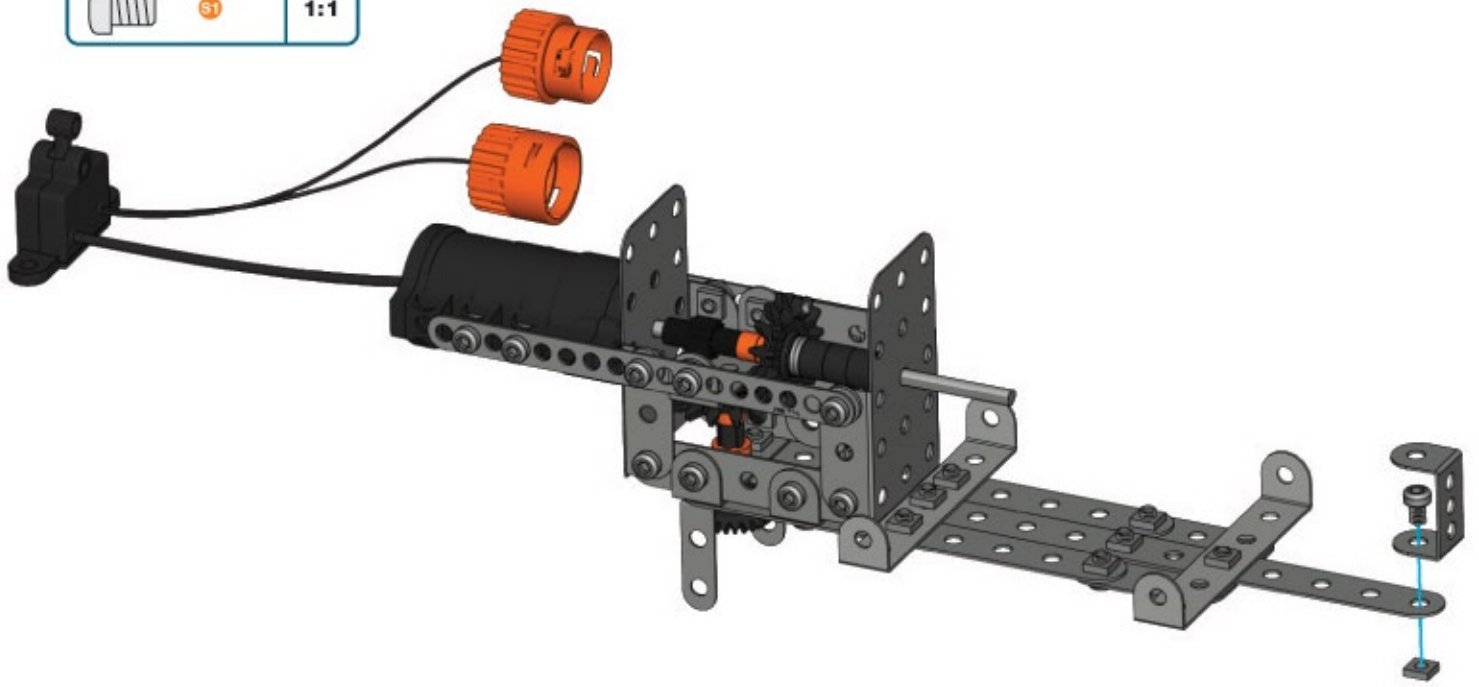

30

		A548 (00402) X1
	5,8mm 15/64"	A637 (00370) X1
		A337 (00370) X1

	S1	1:1
---	-----------	------------



31

0773 x 1

5.8mm 15/64" A637 (000278) x 1
A337 (000278) x 1

5.8mm 15/64" 1:1

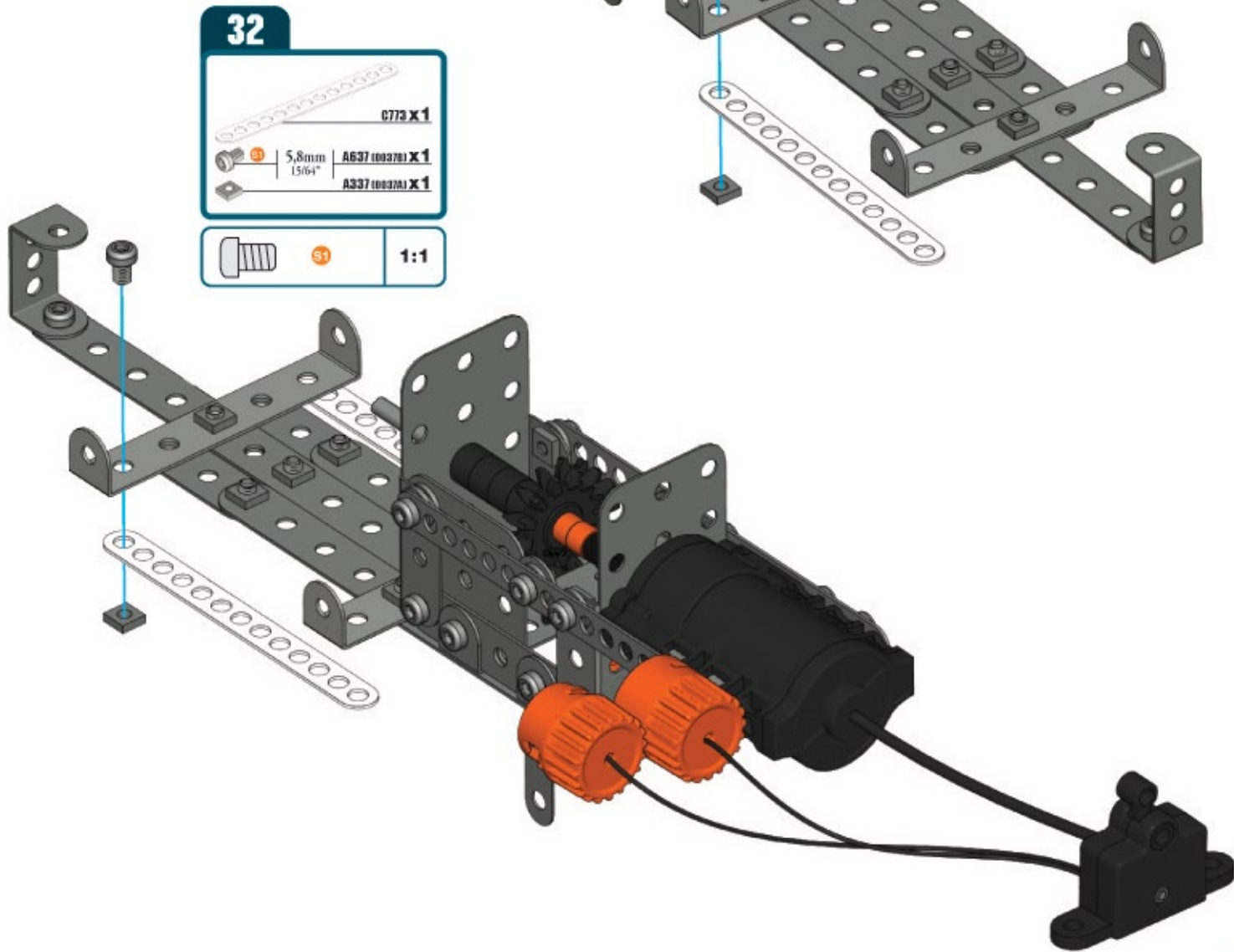

32

0773 x 1

5.8mm 15/64" A637 (000278) x 1
A337 (000278) x 1

5.8mm 15/64" 1:1

33

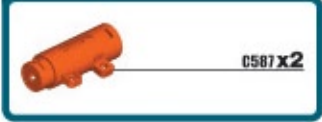

34

33+

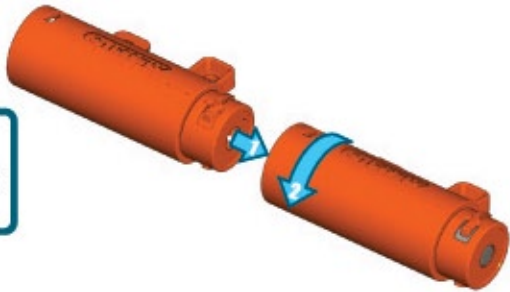
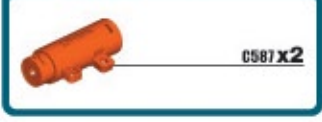

35

32+34+

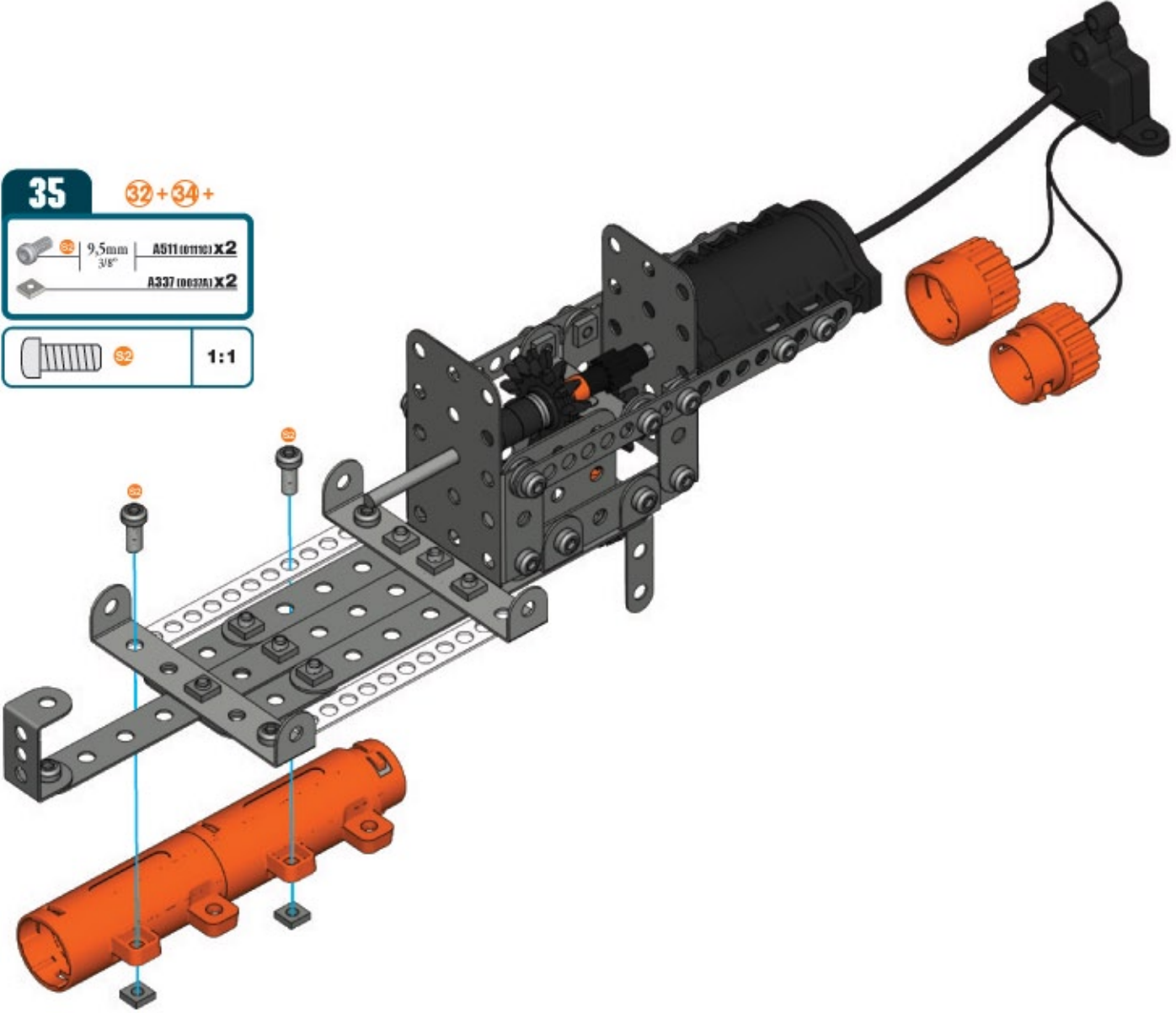

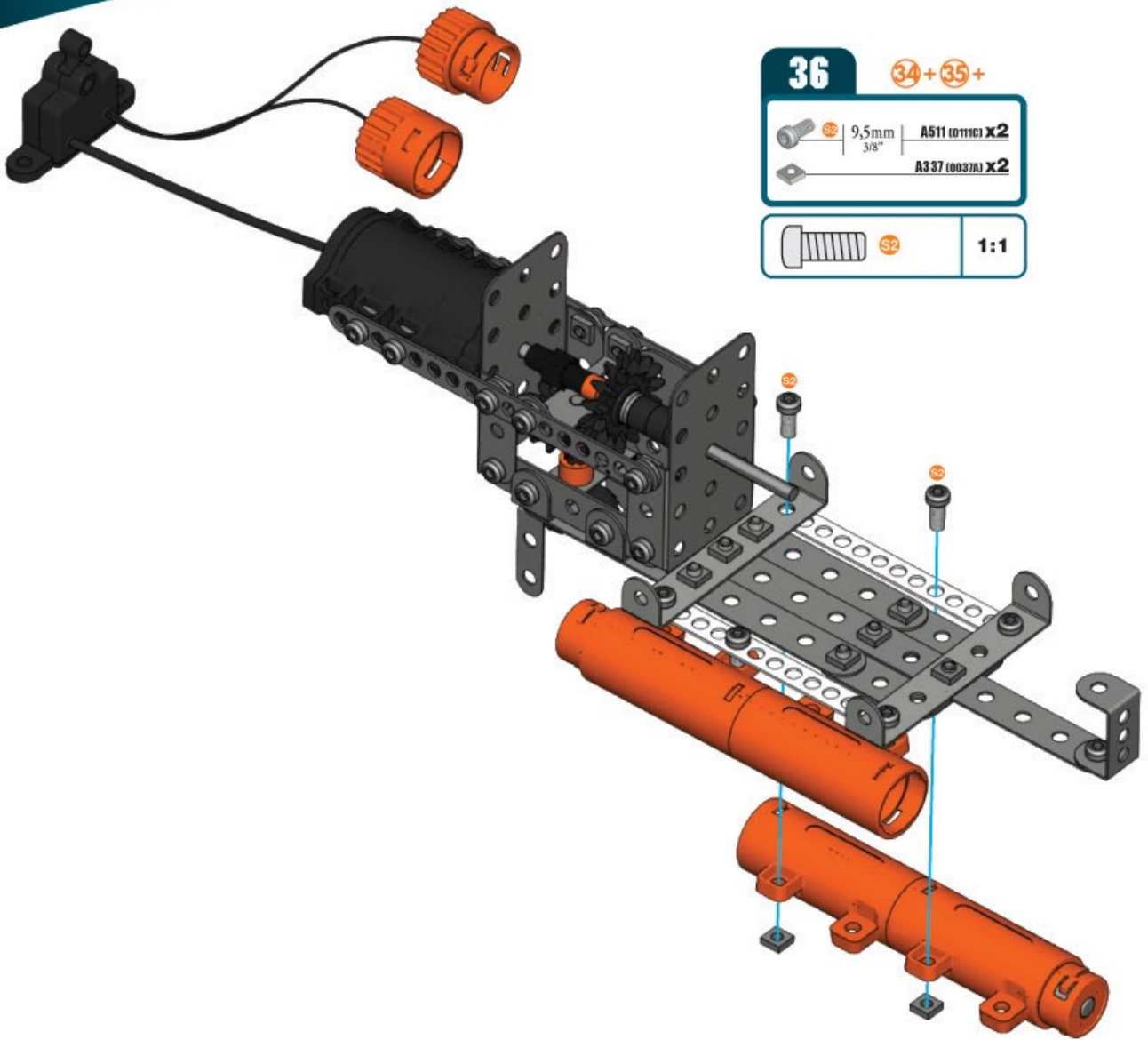





36 34+35+

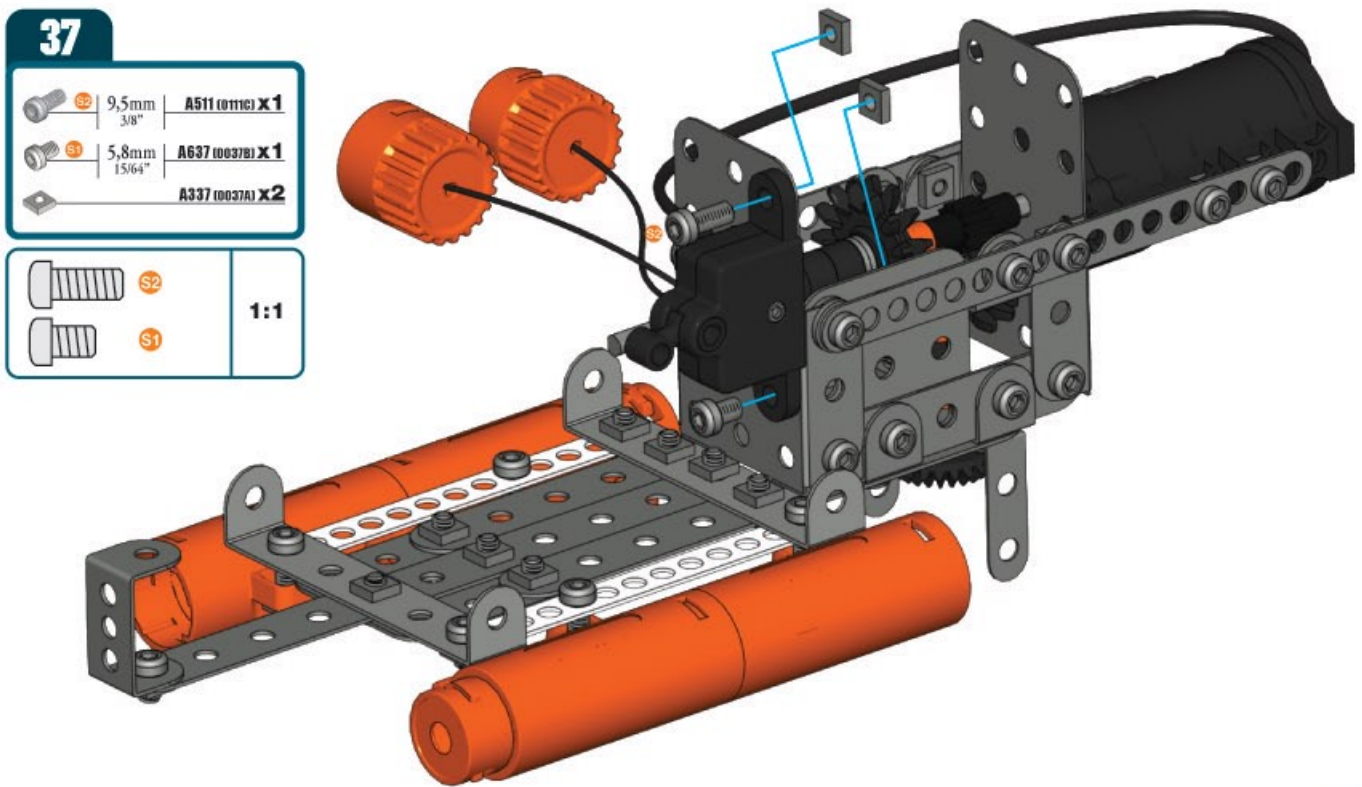

	9,5mm 3/8"	A511 (0111C) x2
		A337 (0037A) x2

	S2	1:1
---	----	-----



37

	9,5mm 3/8"	A511 (0111C) x1
	5,8mm 15/64"	A637 (0037B) x1
		A337 (0037A) x2

	S2	1:1
	S1	

38

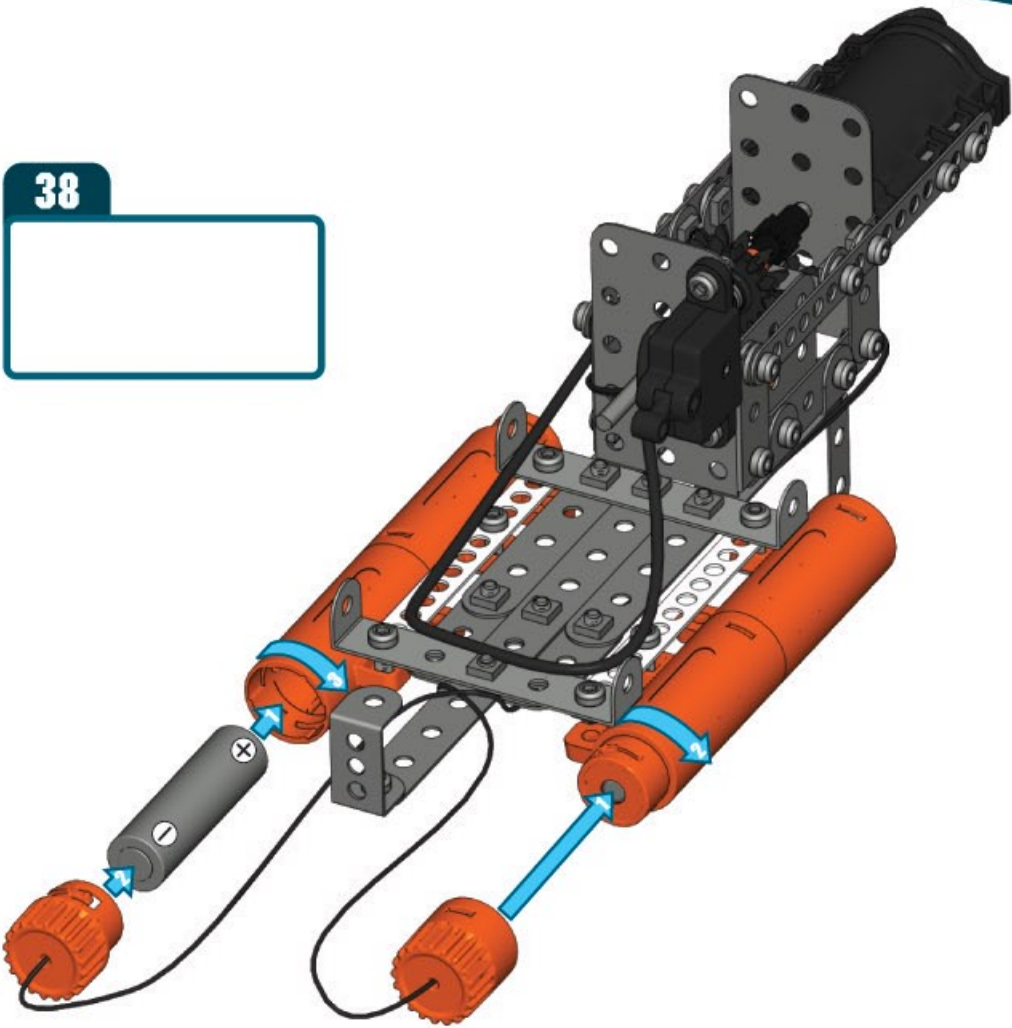

39

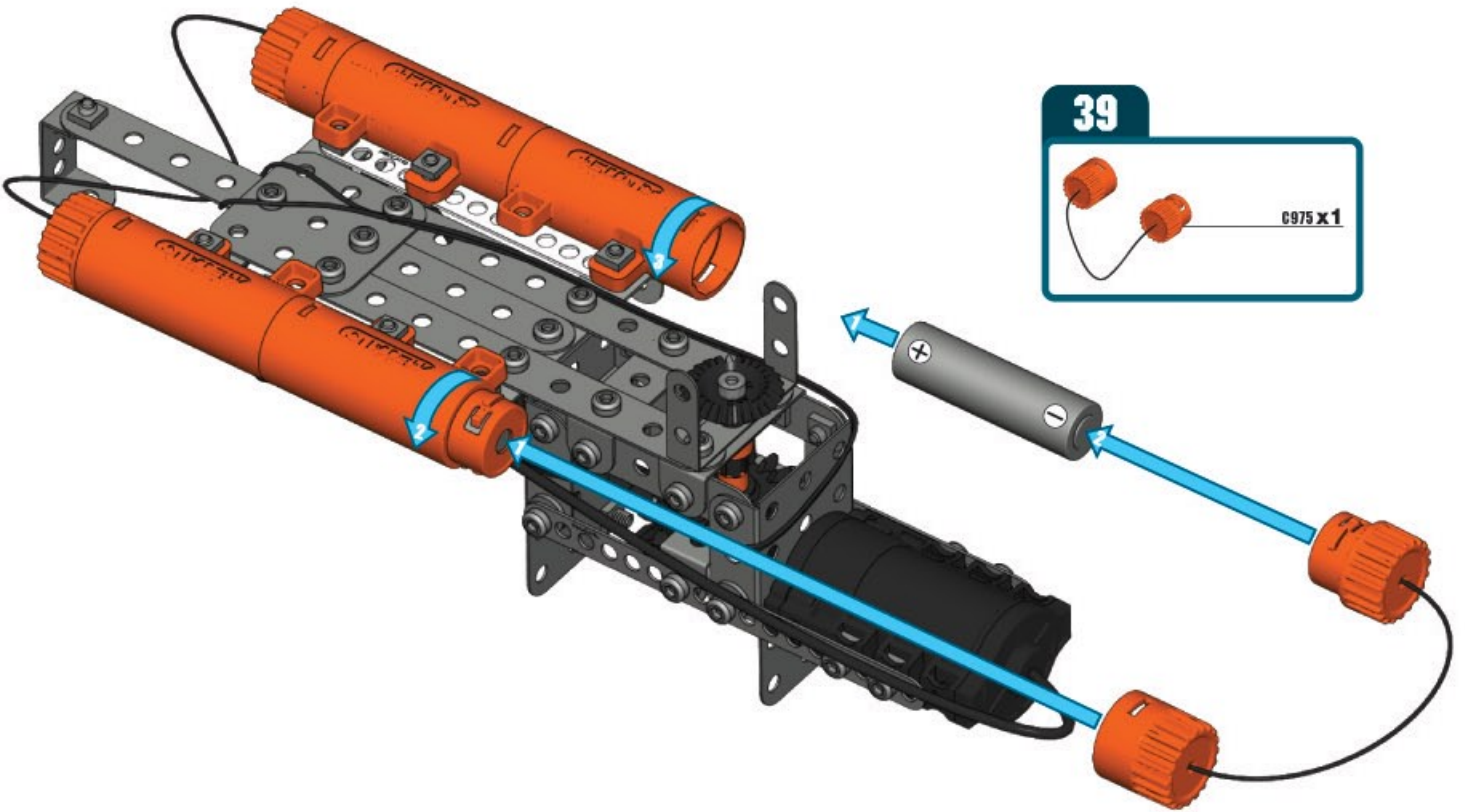

40

- C769 **x1**
- C687 **x1**
- A238 (0038A) **x3**
- A912 (0111E) **x1**
25,4mm | 1"
- A337 (0037A) **x1**

- S5
- A238
- 1:1**

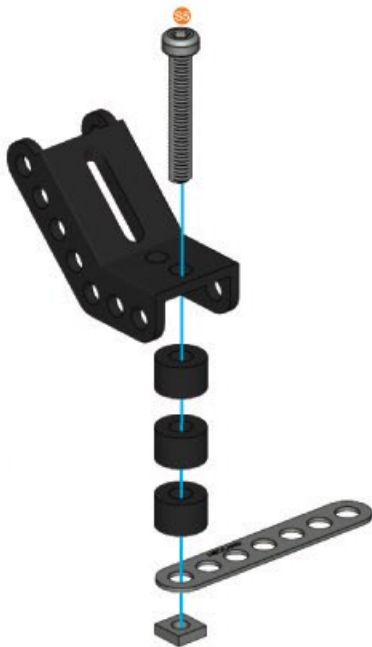

41

- C687 **x1**
- A238 (0038A) **x3**
- A912 (0111E) **x1**
25,4mm | 1"
- A337 (0037A) **x1**

- S5
- A238
- 1:1**



42

39 + 41 +

- A238 (0038A) **x1**
- A411 (0119A) **x1**
12mm | 1/2"
- A337 (0037A) **x1**

- S5
- A238
- 1:1**

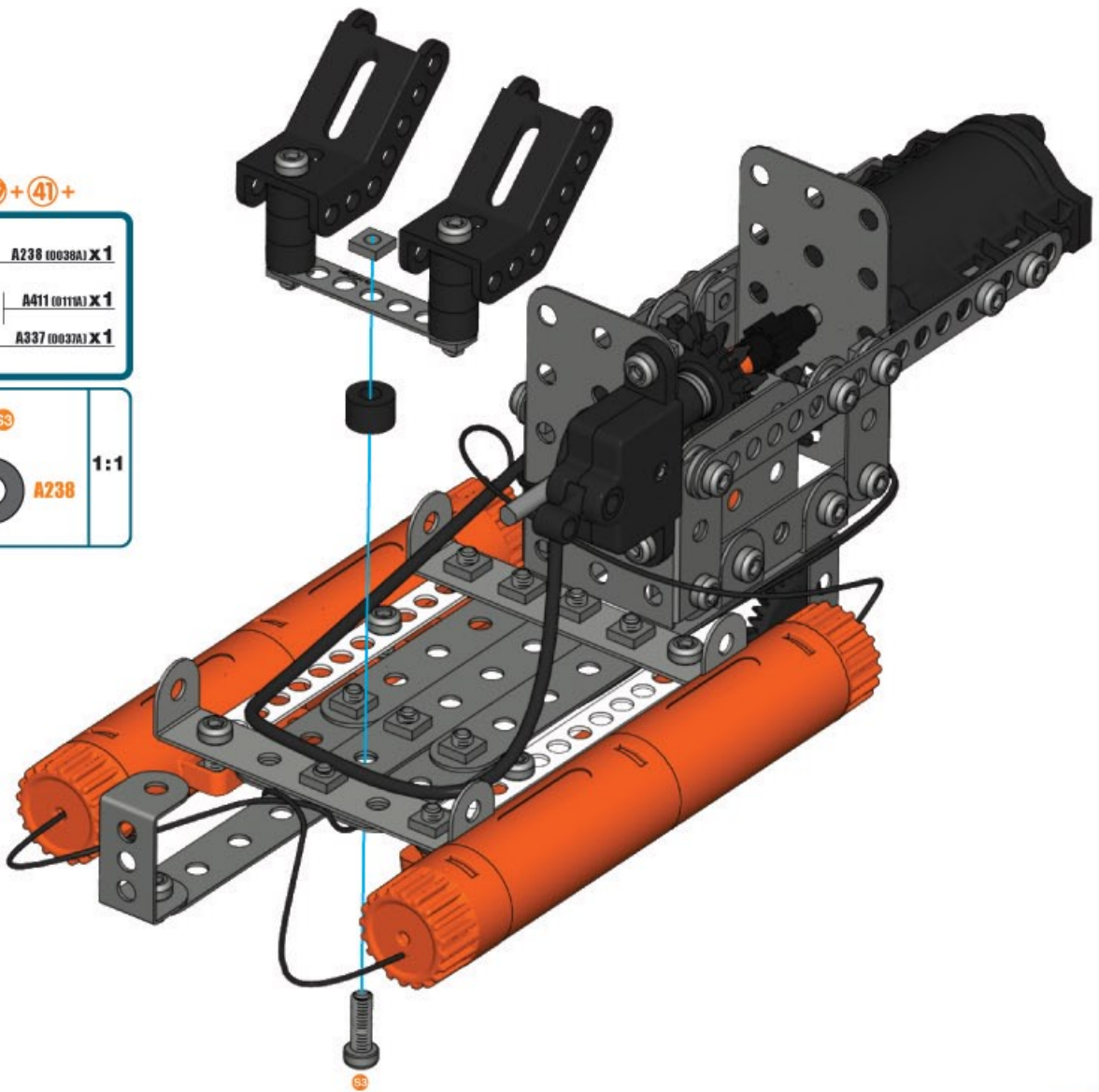

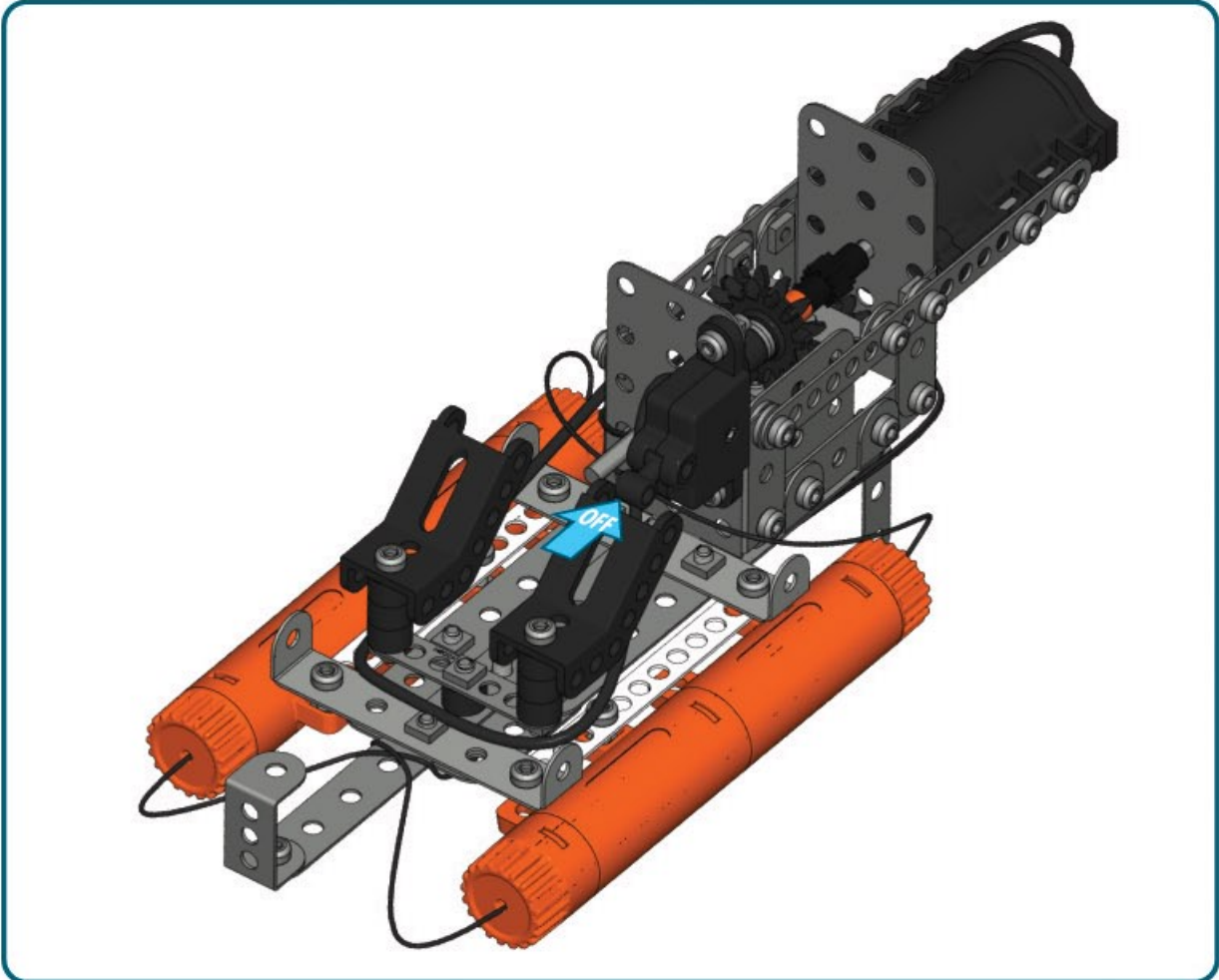
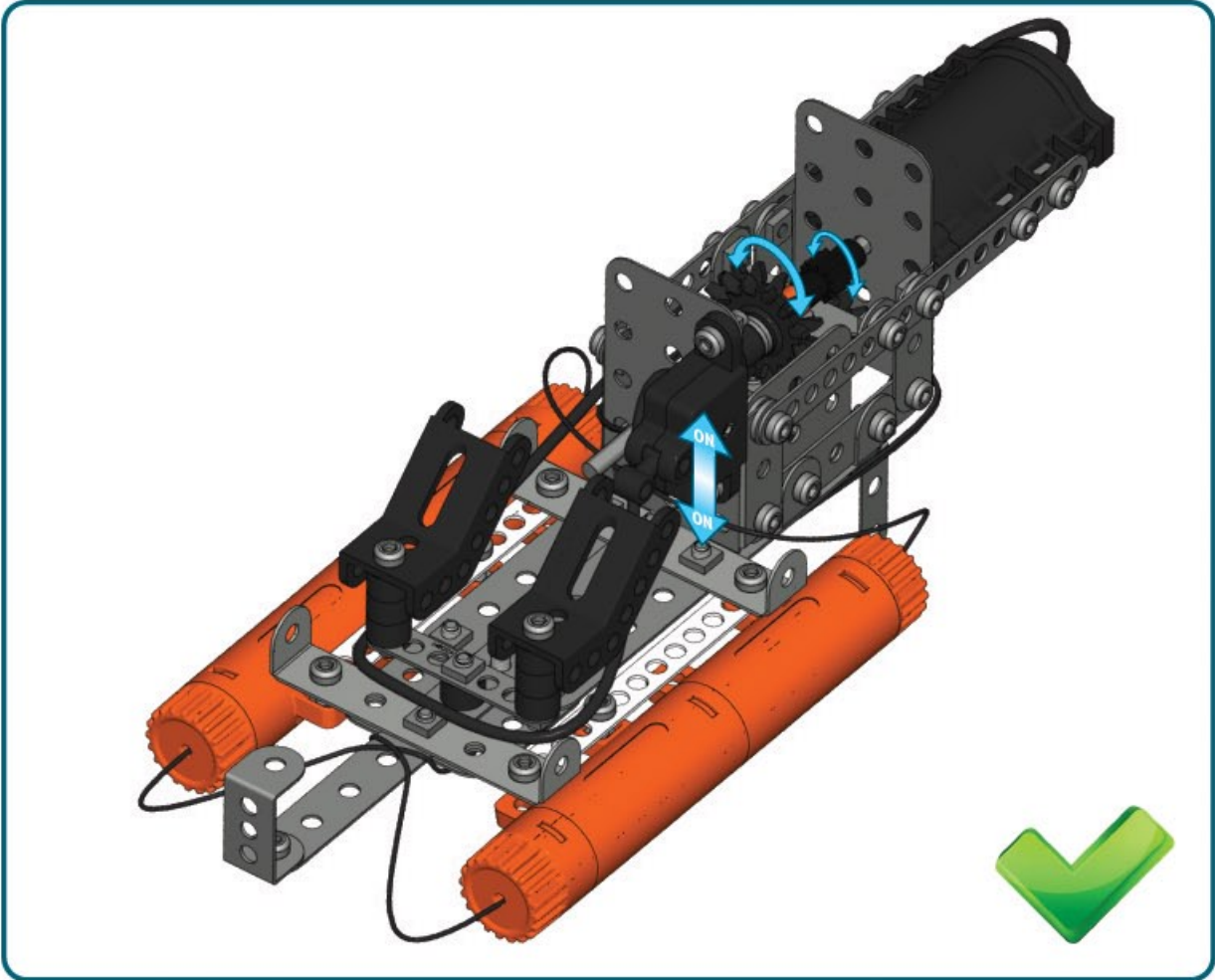



43

 **A342 (0142K) X2**

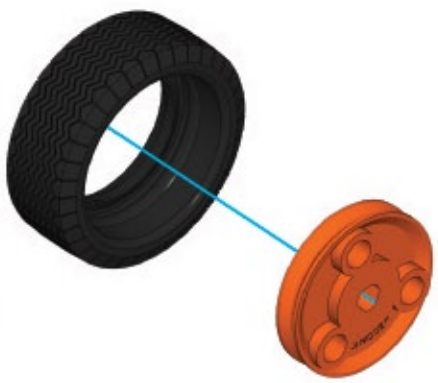
 **A322 (0072CF3F) X2**





44 **A2 + A3 +**

 **90mm 3/12" A316 (0316) X1**

 **C903 X1**

 **A238 (0038A) X4**

 **A259 (0059C) X2**

  **A238**

1:1

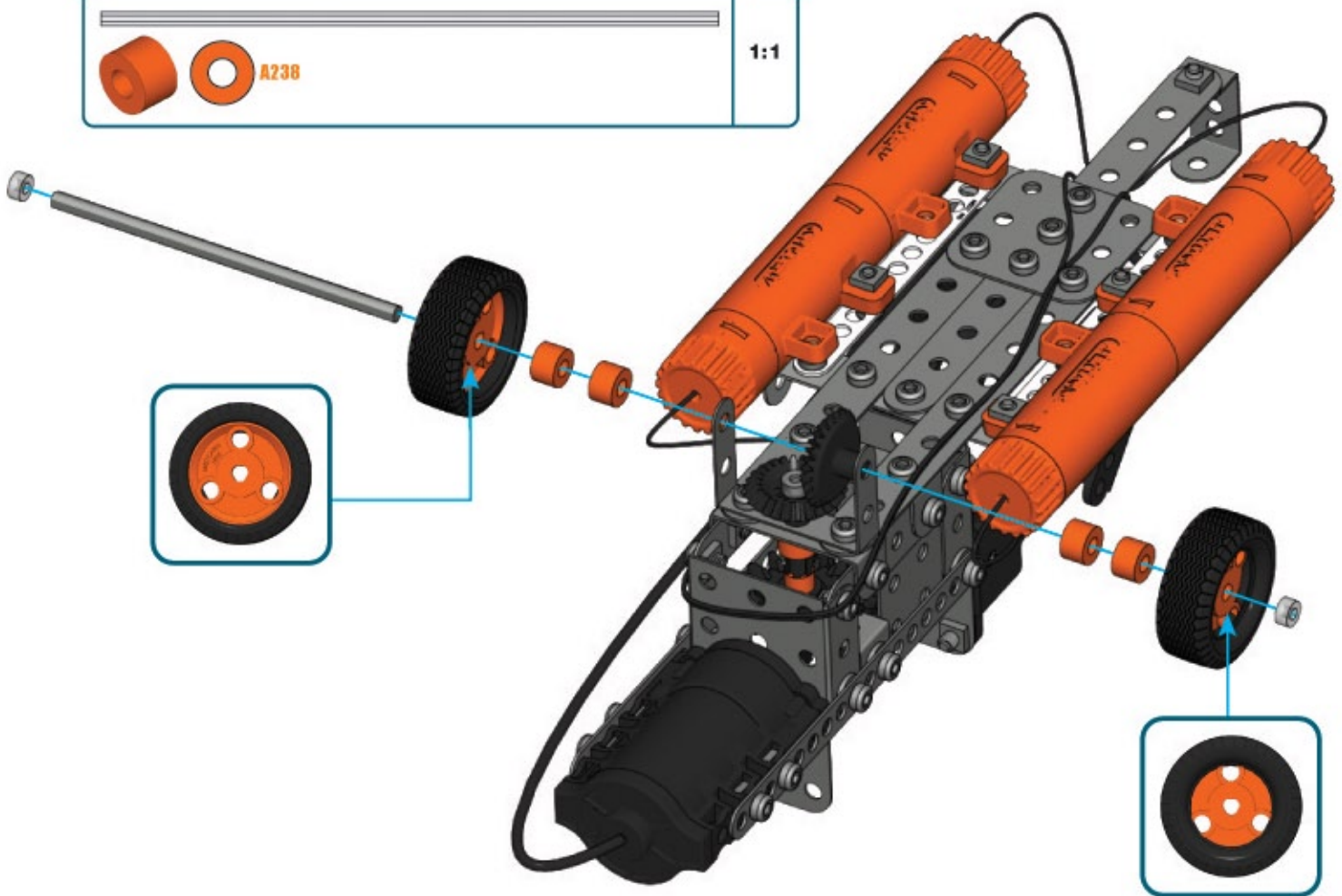

45

- A436 (0611A) X 1
- A238 (0638A) X 1
- 19mm 3/4" A637 (0637B) X 1
- A337 (0037A) X 1

- 1:1
- A238

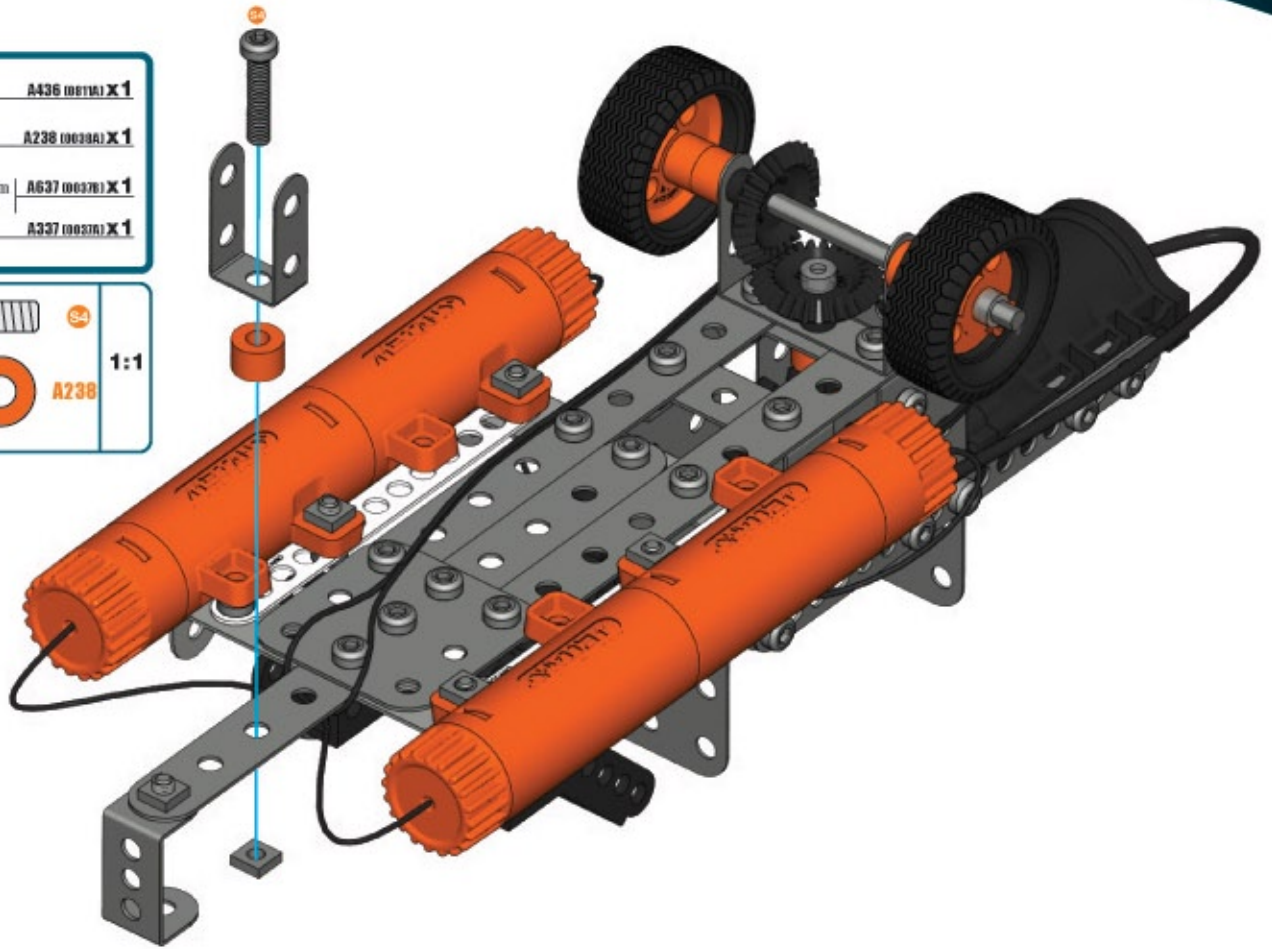



46



- A364 (0162D) X 2
- A523 (00236P3P) X 2



47

45 + 46 +

-  50mm $\frac{1}{2}$ " | A317 (0317) X 1
-  | A238 (0238) X 2
-  | A259 (0259) X 2

-   A238
- 1:1

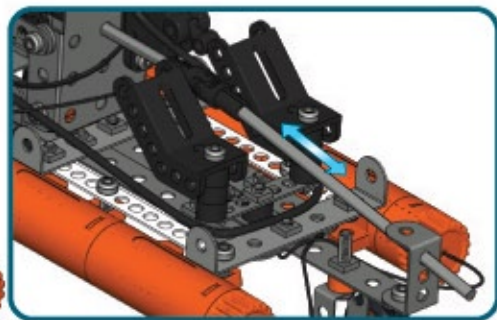
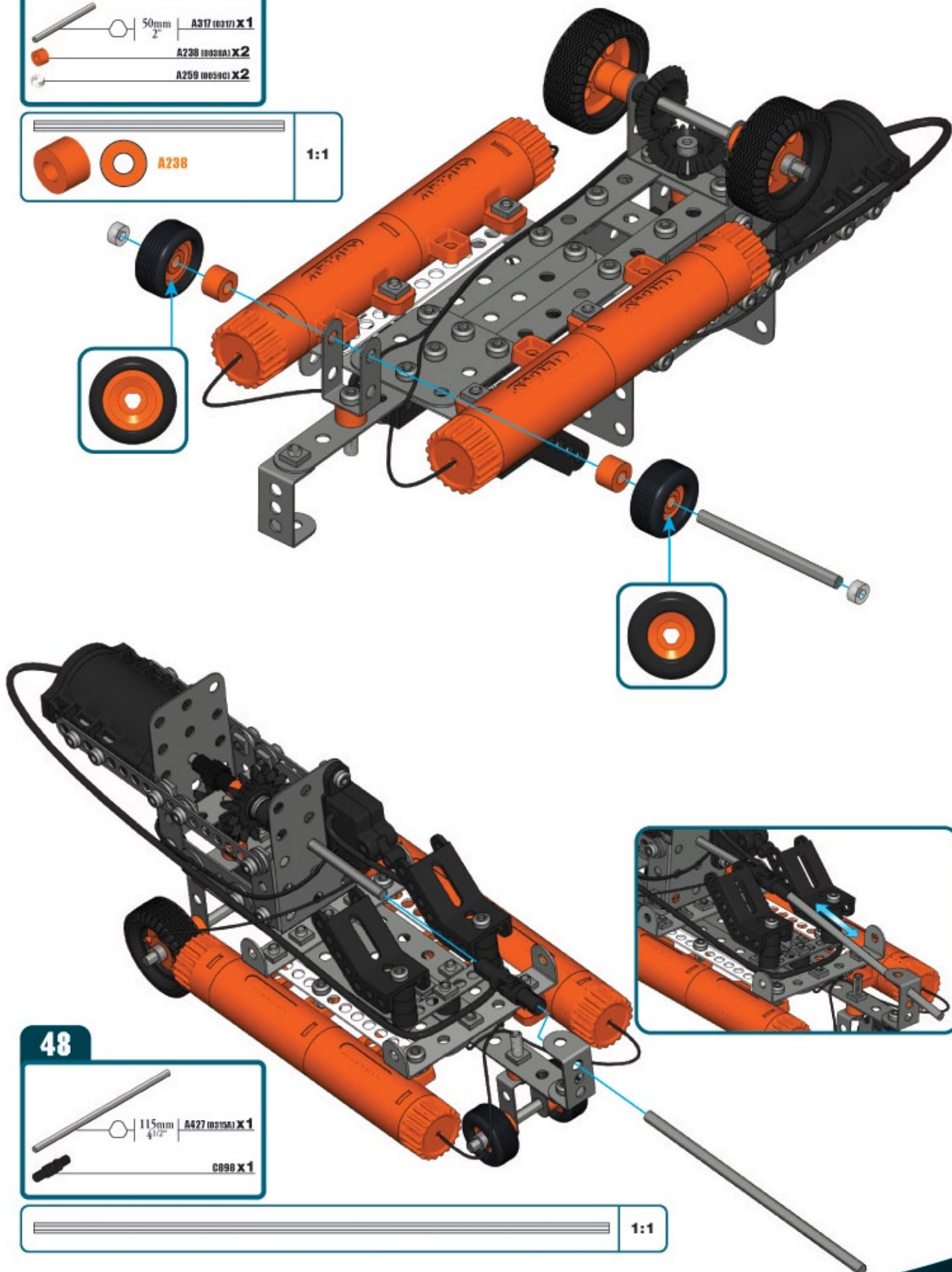

48

-  115mm $\frac{4 1}{2}$ " | A427 (0427) X 1
-  | C098 X 1

-  1:1

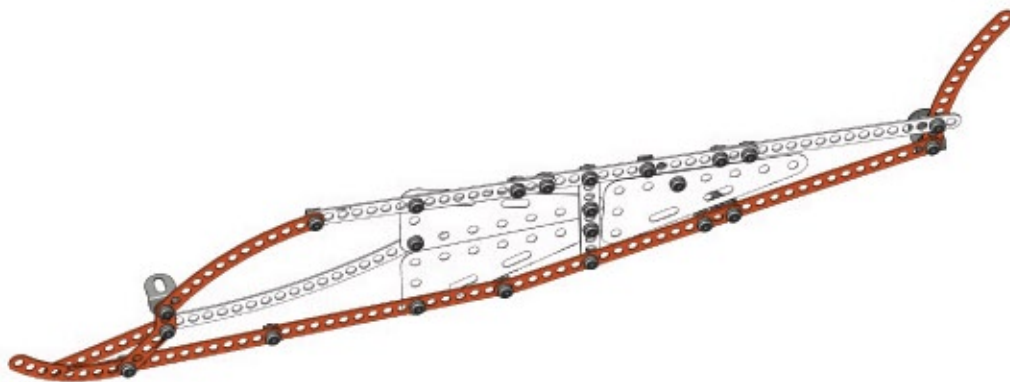

49

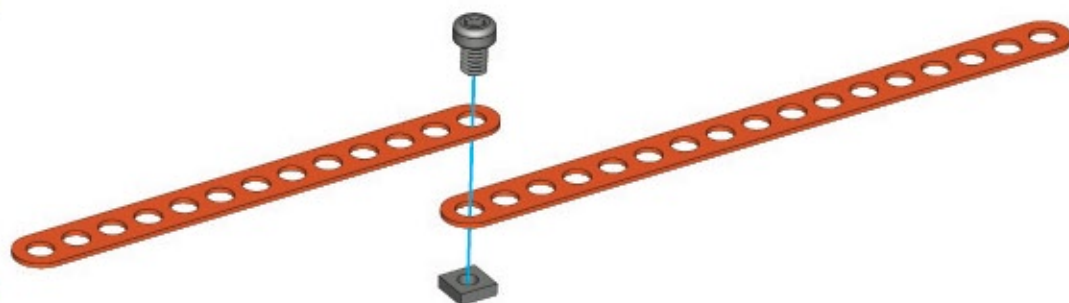
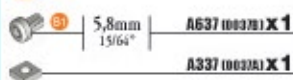
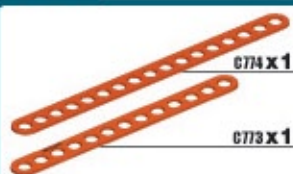

50

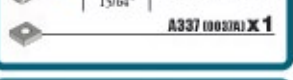

51

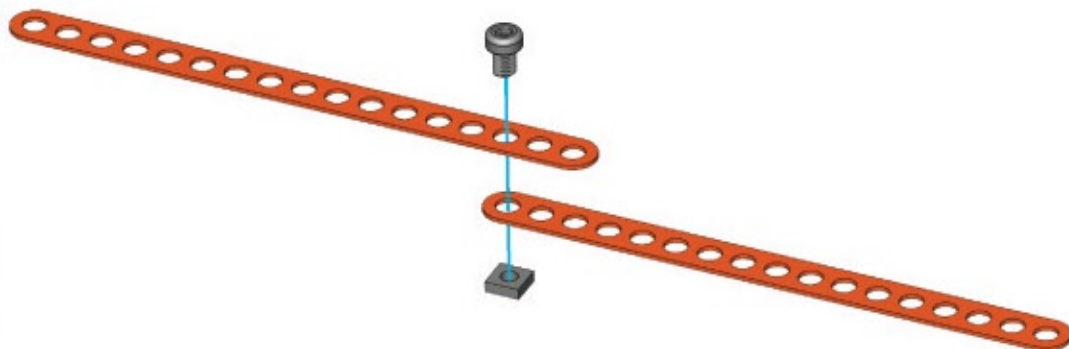
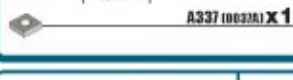
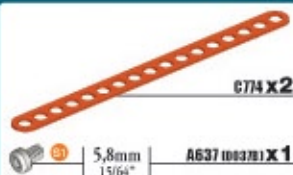

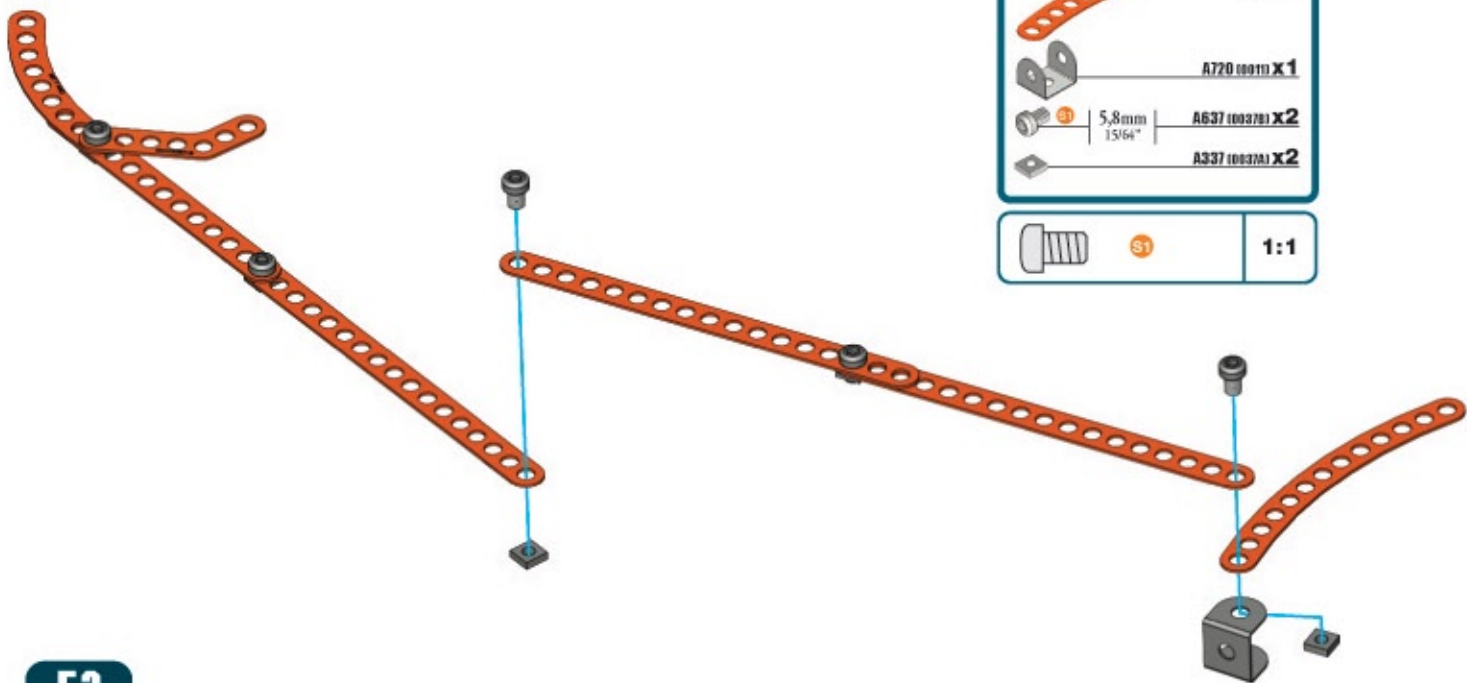

52 (50) + (51) +

C779 x1

A720 (00010) x1

A637 (00028) x2

A337 (00020) x2

5,8mm 15/64"

S1

1:1

53

C774 x3

A637 (00028) x4

A337 (00020) x4

5,8mm 15/64"

S1

1:1

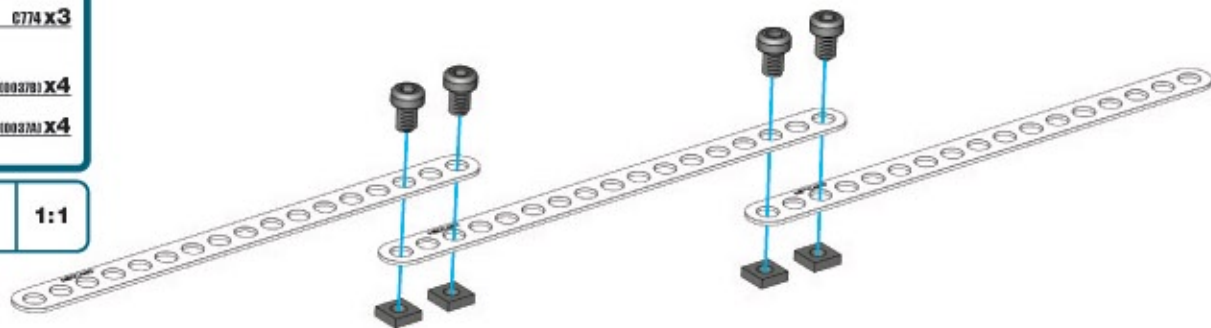

54

C779 x1

A637 (00028) x1

A337 (00020) x1

5,8mm 15/64"



S1

1:1





55

52 + 54 +

	A012 (0012) X 1
 5,8mm 15/64"	A637 (0037B) X 1
	A337 (0037A) X 1



	51	1:1
---	----	-----

**56**

 5,8mm 15/64"	A637 (0037B) X 1
	A337 (0037A) X 1

	51	1:1
---	----	-----

**57**

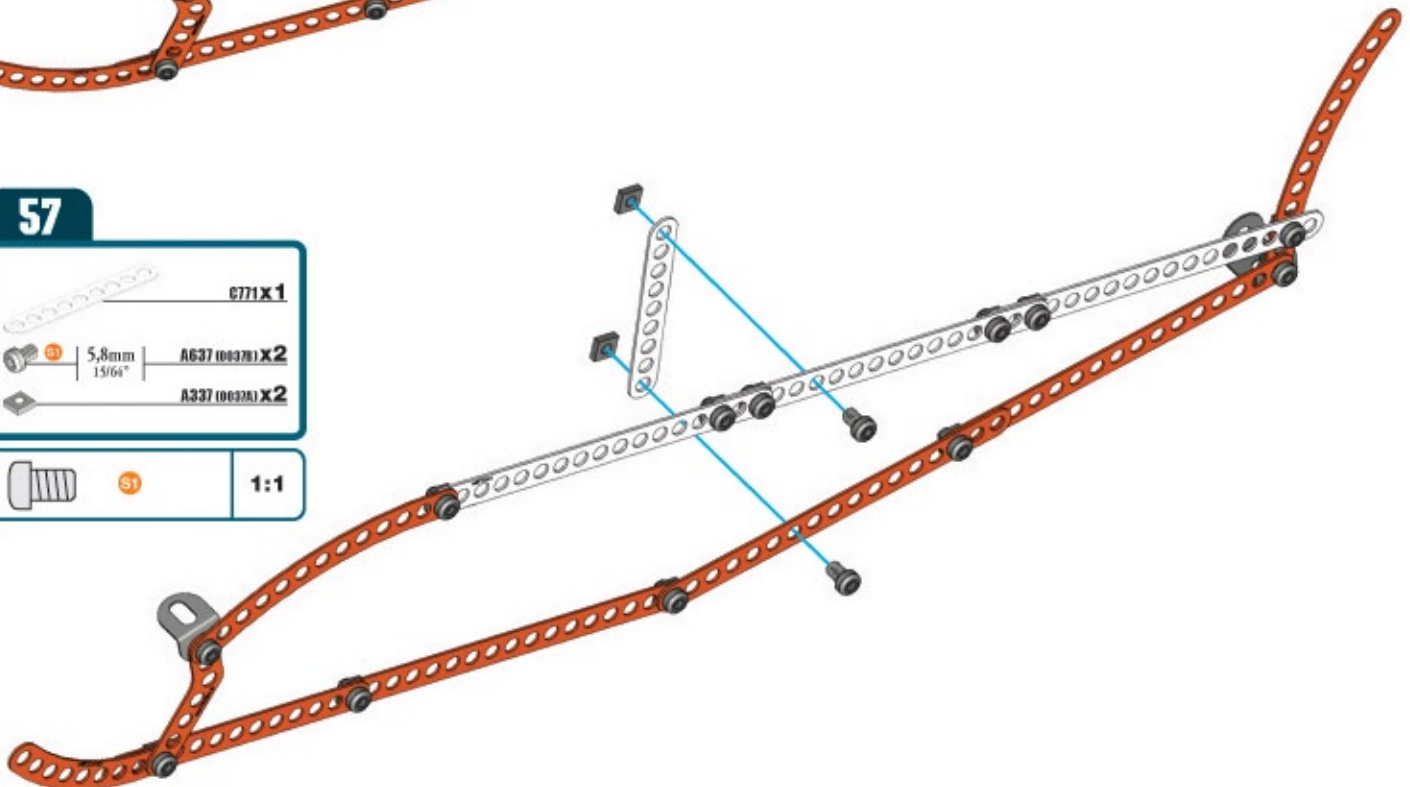

	C771 X 1
 5,8mm 15/64"	A637 (0037B) X 2
	A337 (0037A) X 2

	51	1:1
---	----	-----

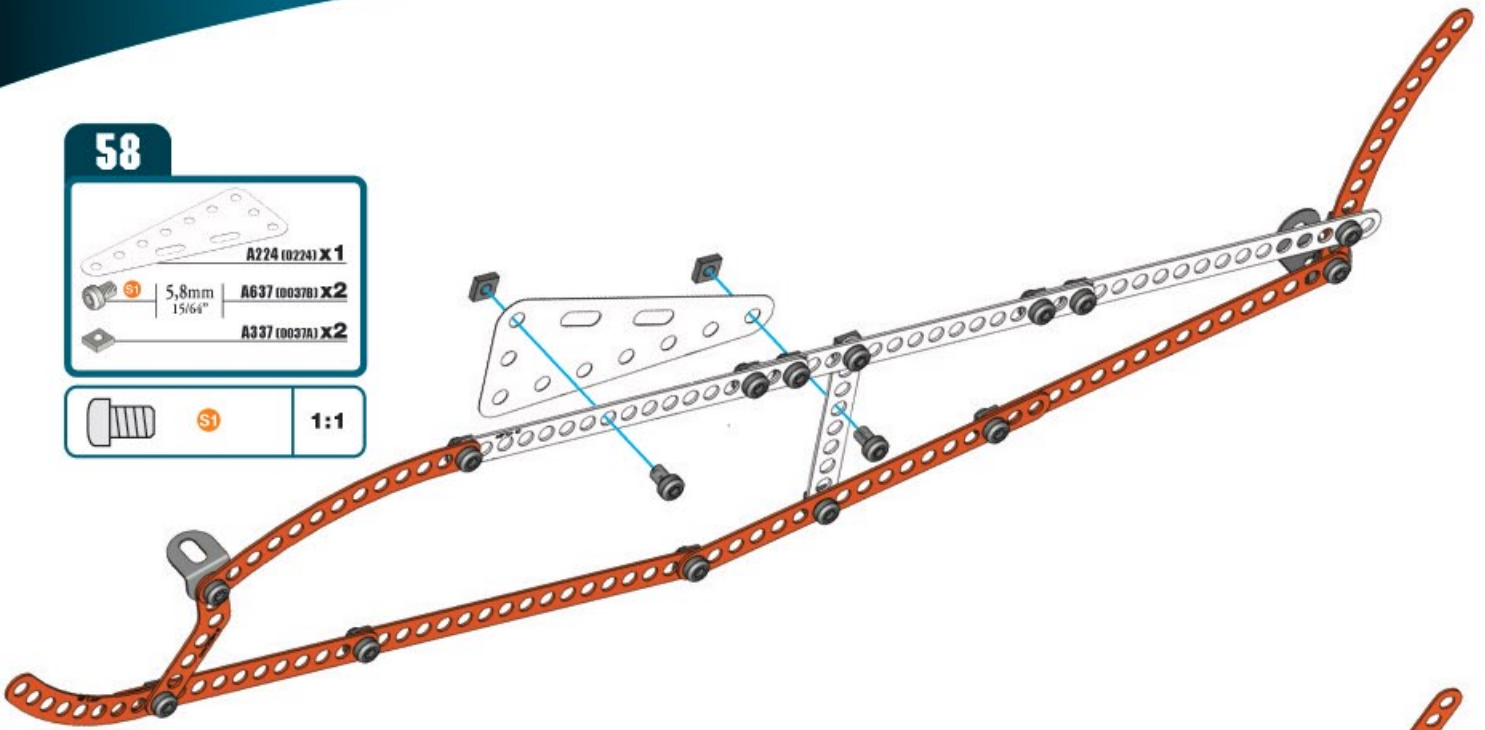
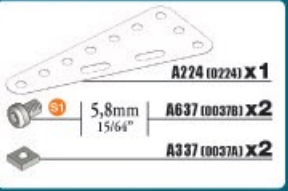
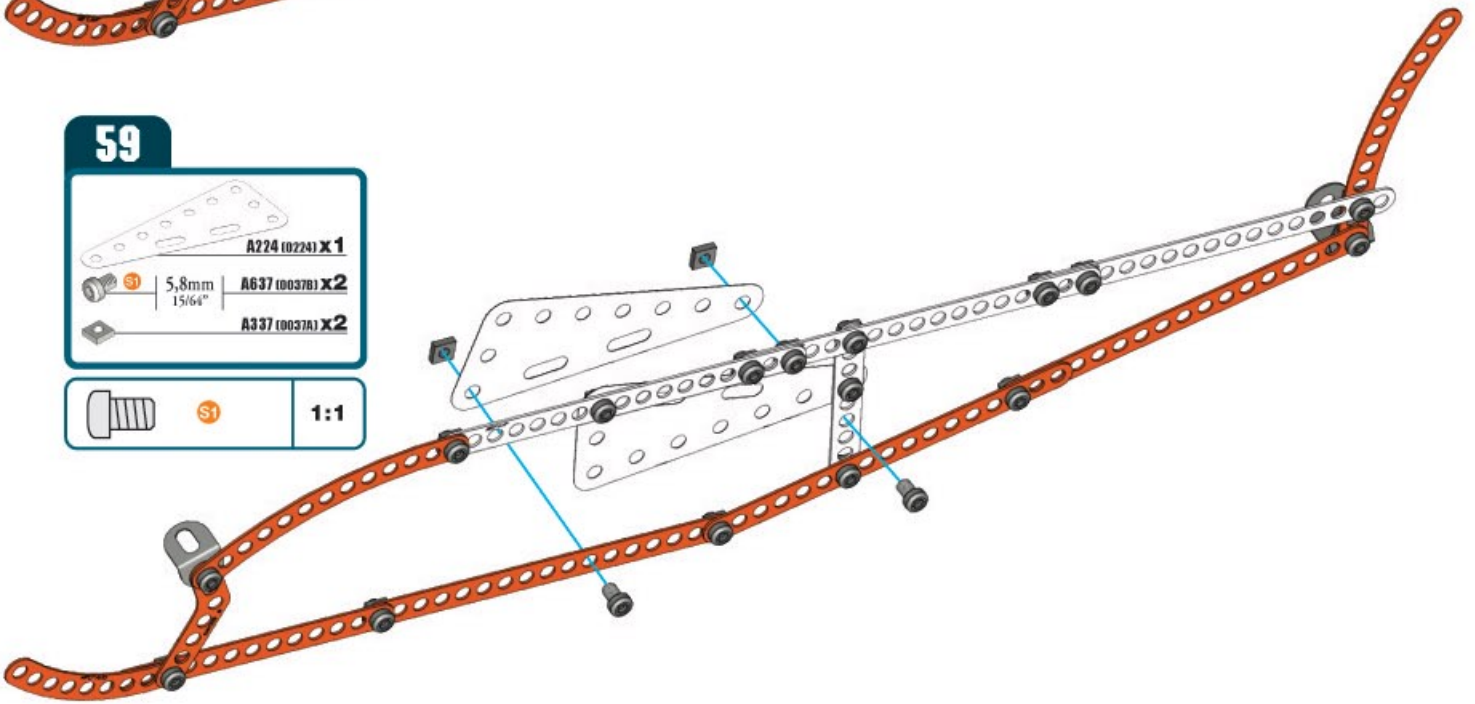
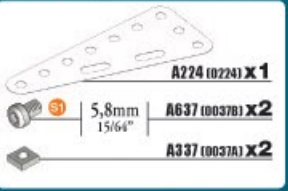
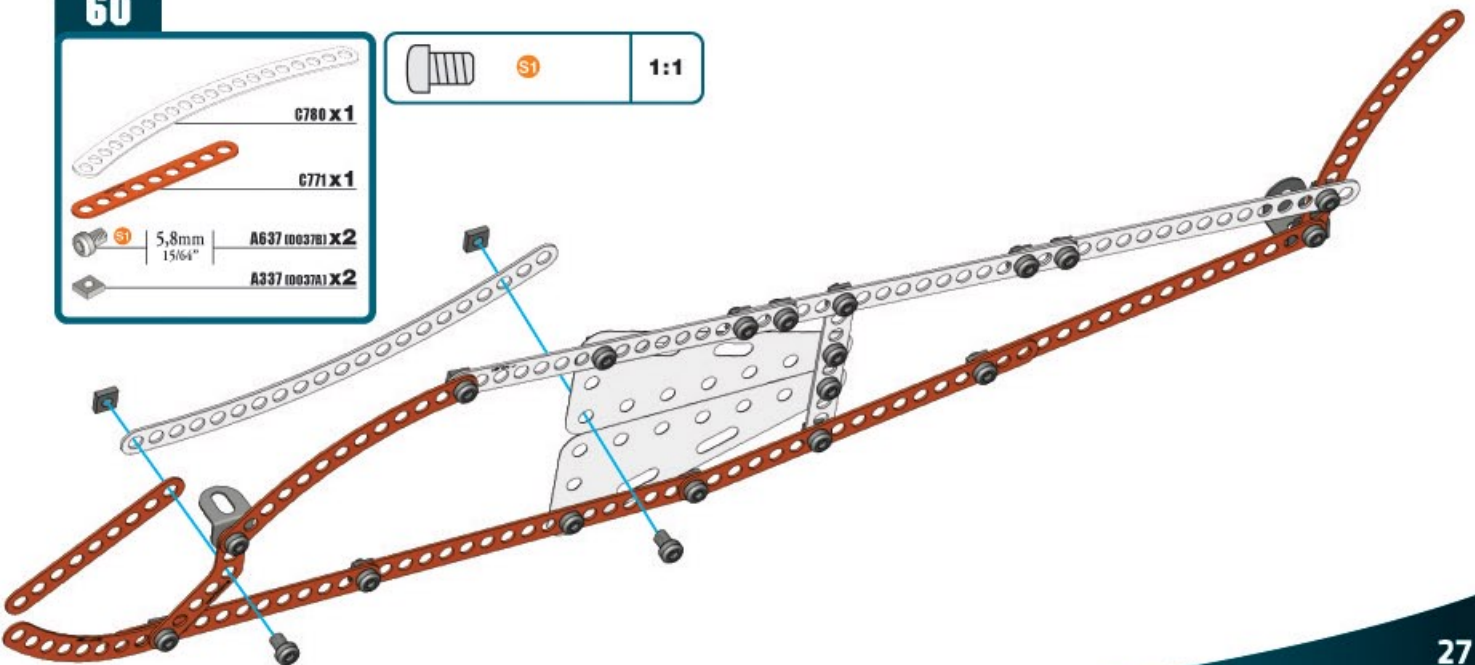
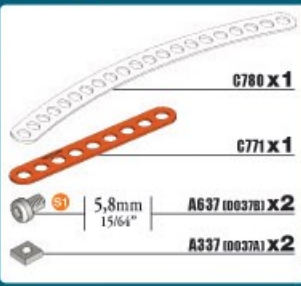





58**59****60**

61

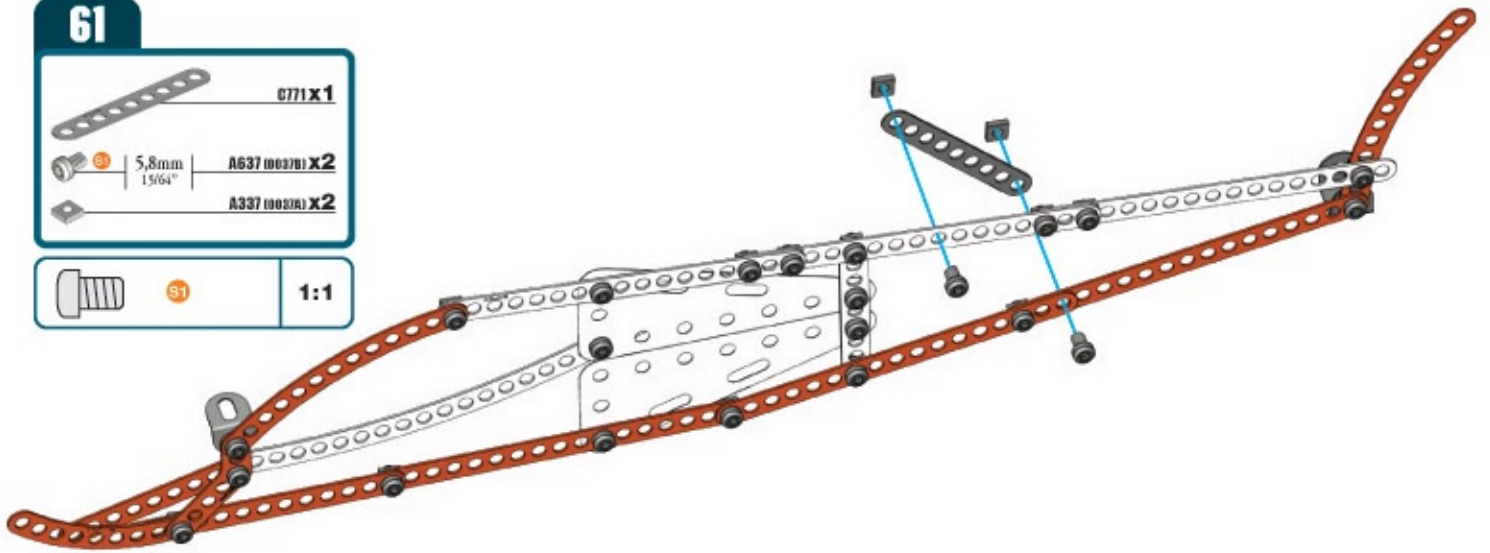
 **0771 x1**
 **5,8mm** | **A637 (00370) x2**
 **A337 (00370) x2**

 **S1** | **1:1**

**62**

 **A224 (0224) x1**
 **5,8mm** | **A637 (00370) x1**
 **A337 (00370) x1**

 **S1** | **1:1**

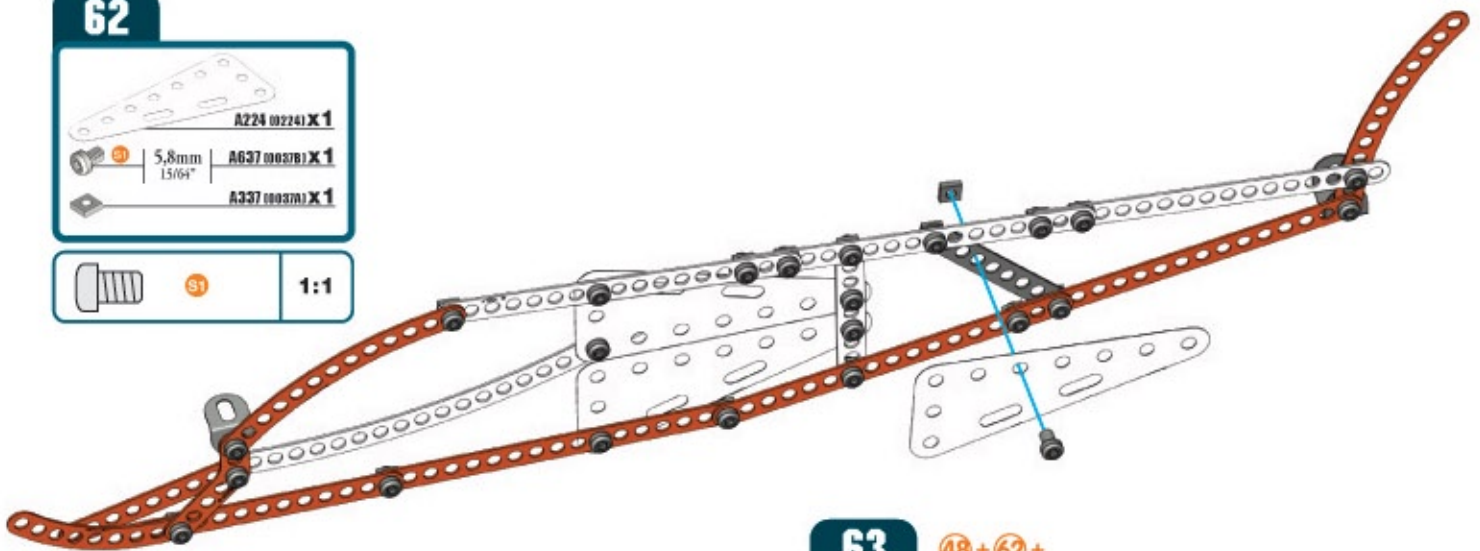
**63****48 + 62 +**

 **A238 (00300) x2**
 **12mm** | **A411 (01110) x2**
 **A337 (00370) x2**

 **S3** | **1:1**
 **A238**

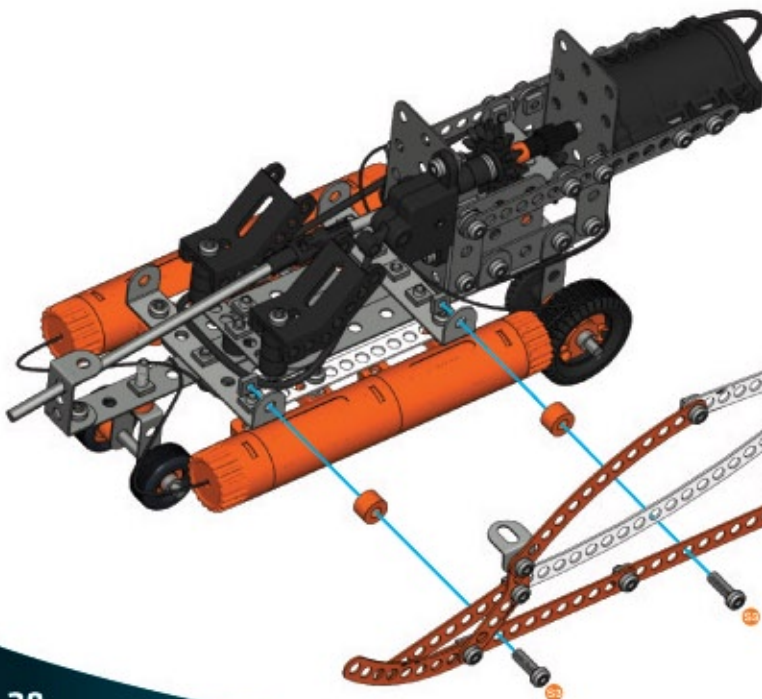

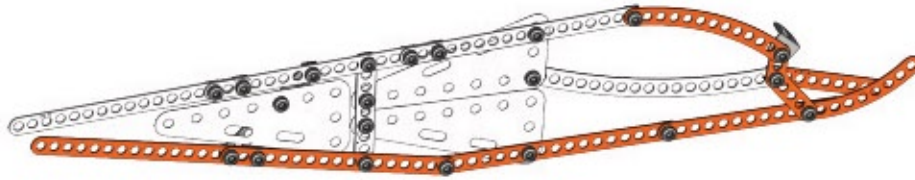

64

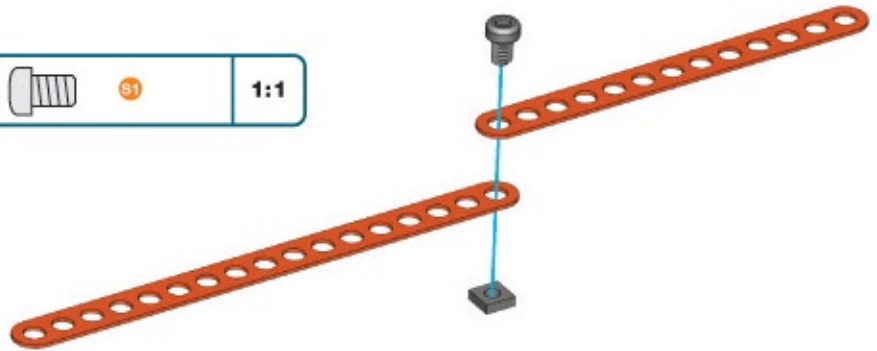
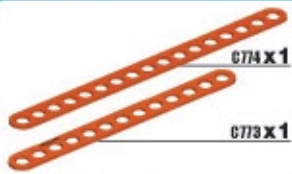

65

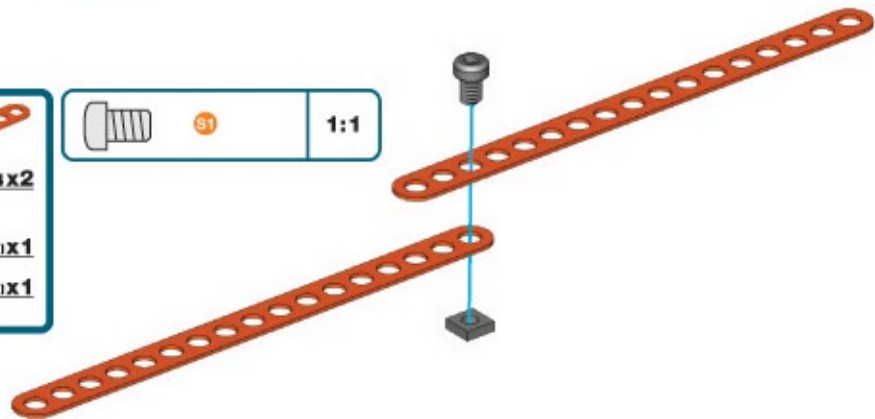
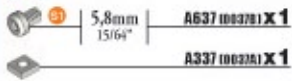

66

64 + 65 +

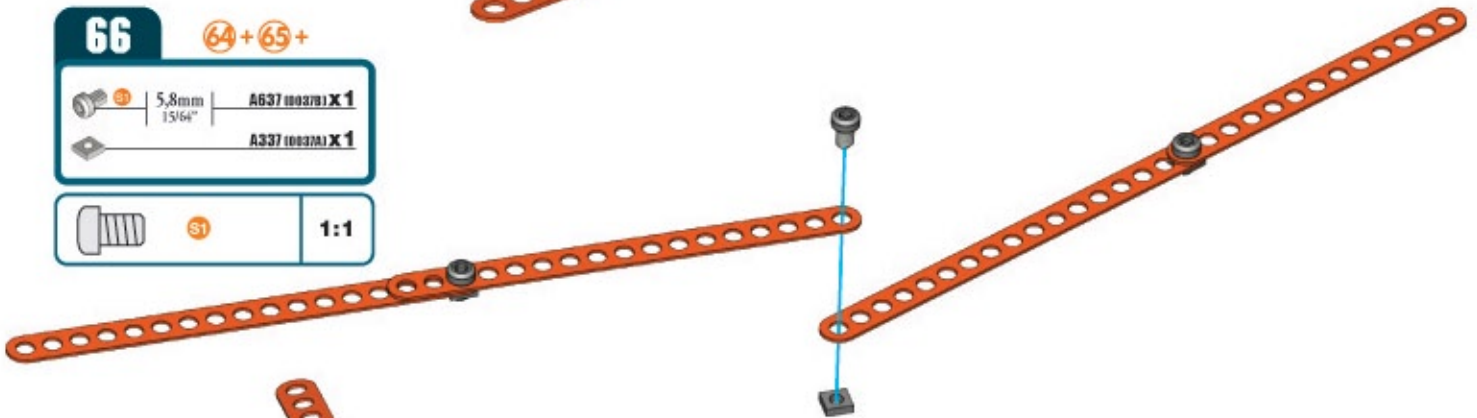
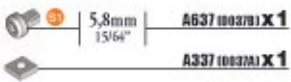

67

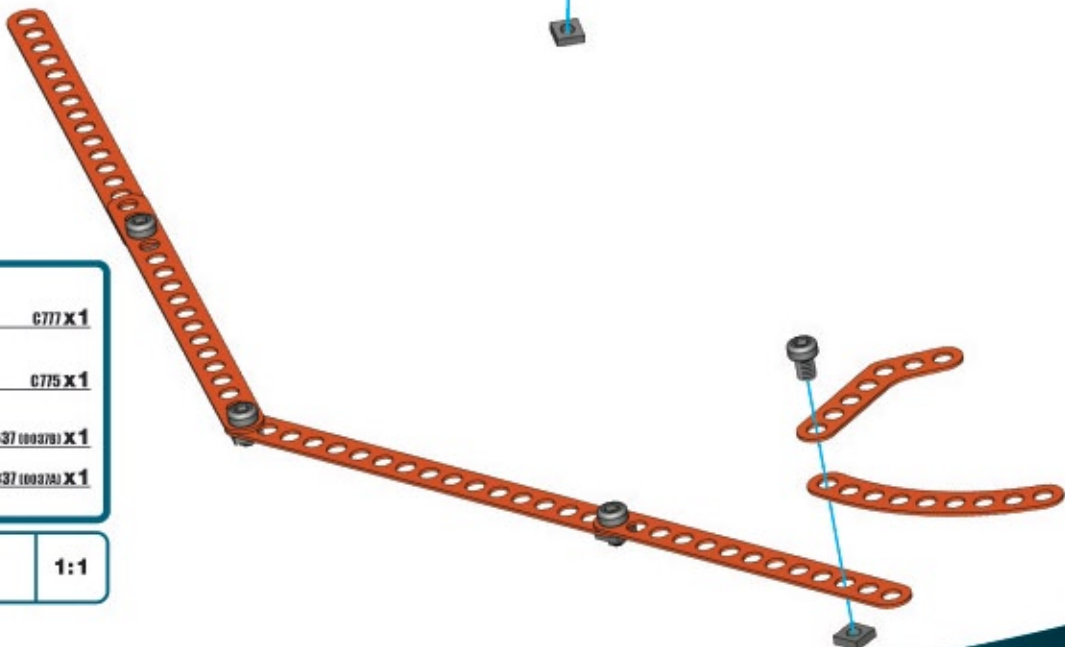

68

A714 x3

5,8mm 15/64" **A637 (000370) x4**

A337 (000370) x4

S1 **1:1**

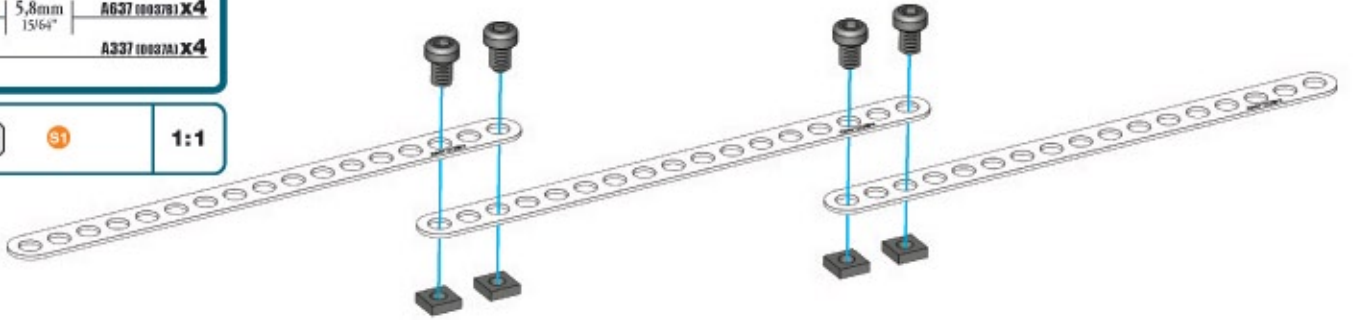

69

C771 x1

5,8mm 15/64" **A637 (000370) x1**

A337 (000370) x1

S1 **1:1**

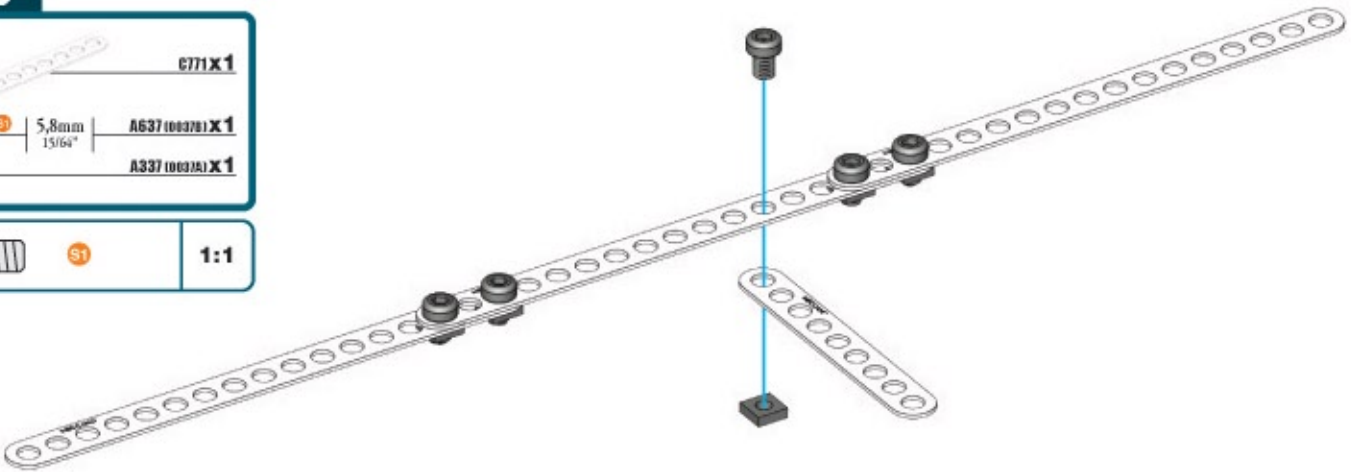

70

C779 x1



5,8mm 15/64" **A637 (000370) x1**

A337 (000370) x1

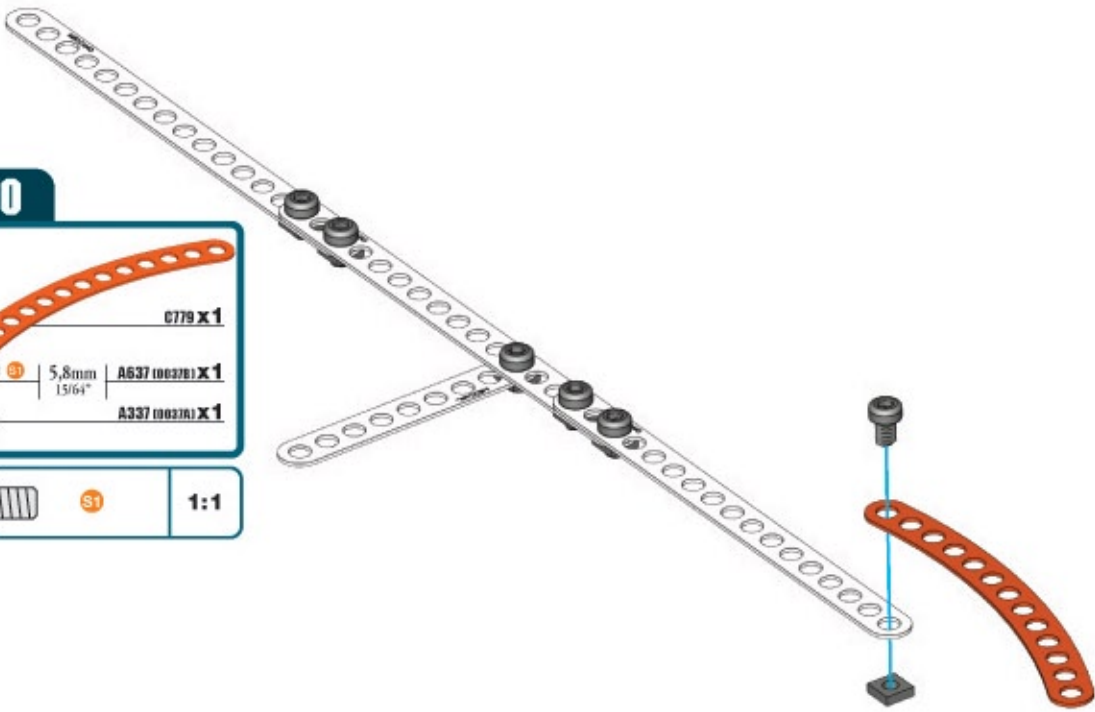
S1 **1:1**



71**67+70+**

	A012 (0012) X1
	A637 (0037) X1
	A337 (0037) X1

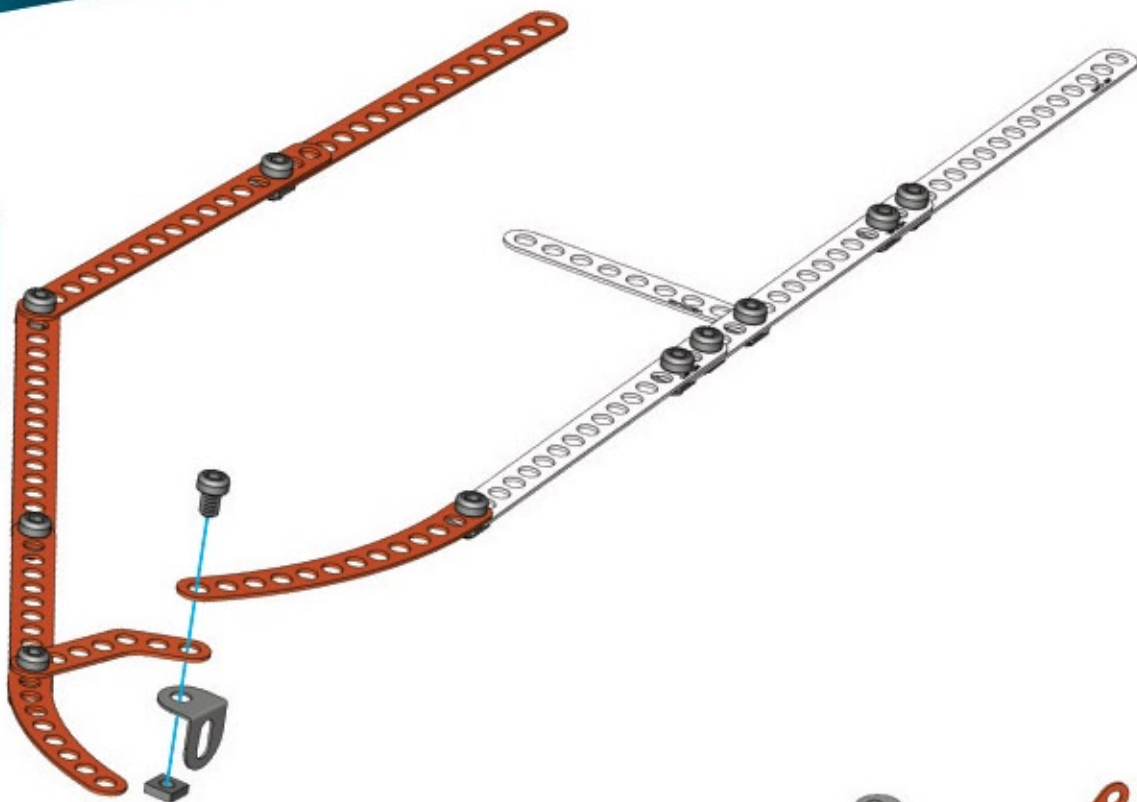

	S1	1:1
--	-----------	------------

**72**

	A637 (0037) X1
	A337 (0037) X1

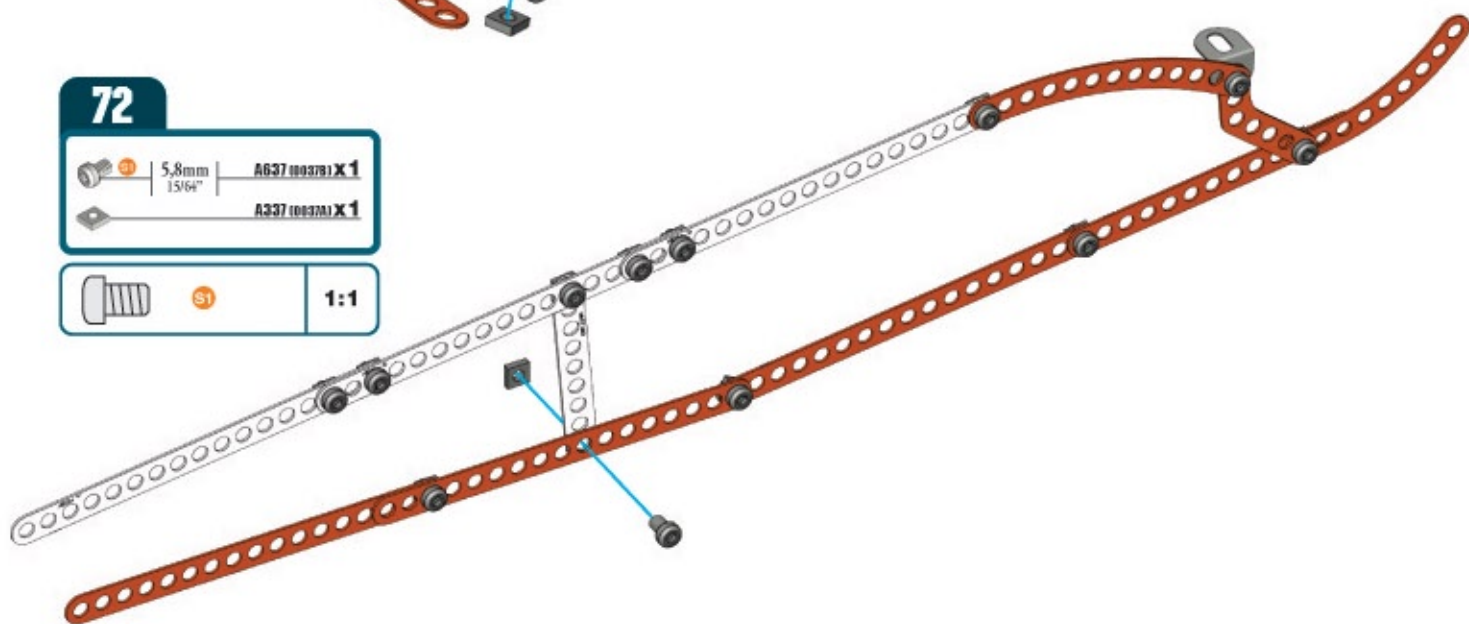
	S1	1:1
---	-----------	------------

**73**

	0771 X1
	A637 (0037) X2
	A337 (0037) X2

	S1	1:1
---	-----------	------------

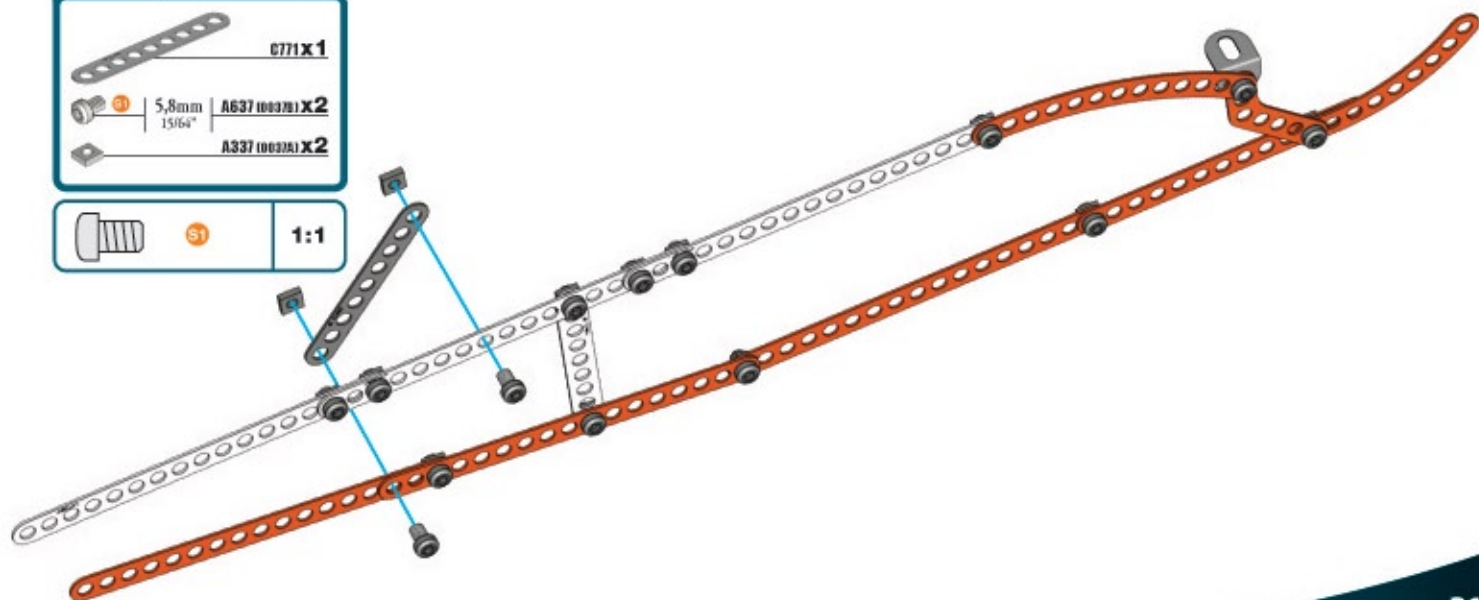

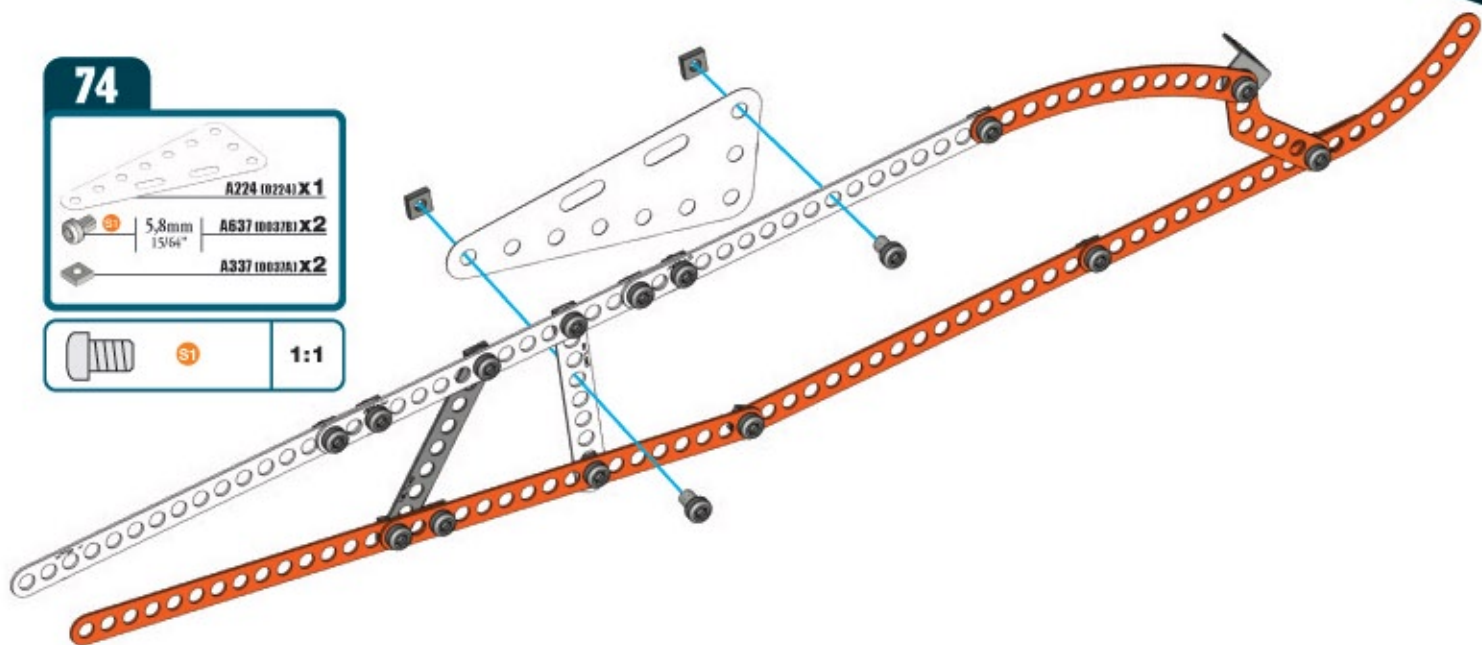
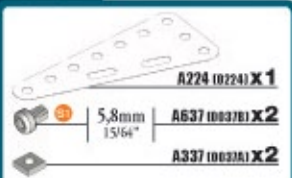
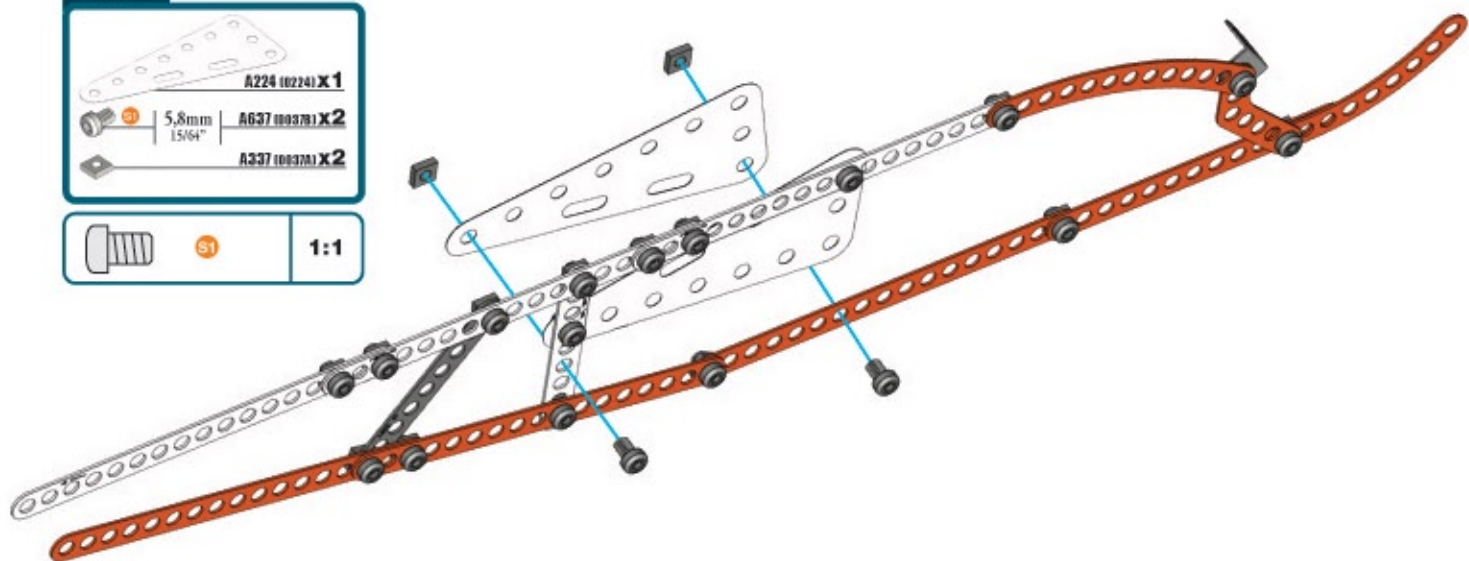
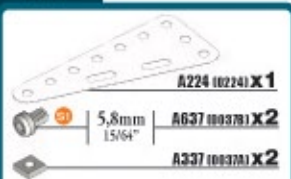
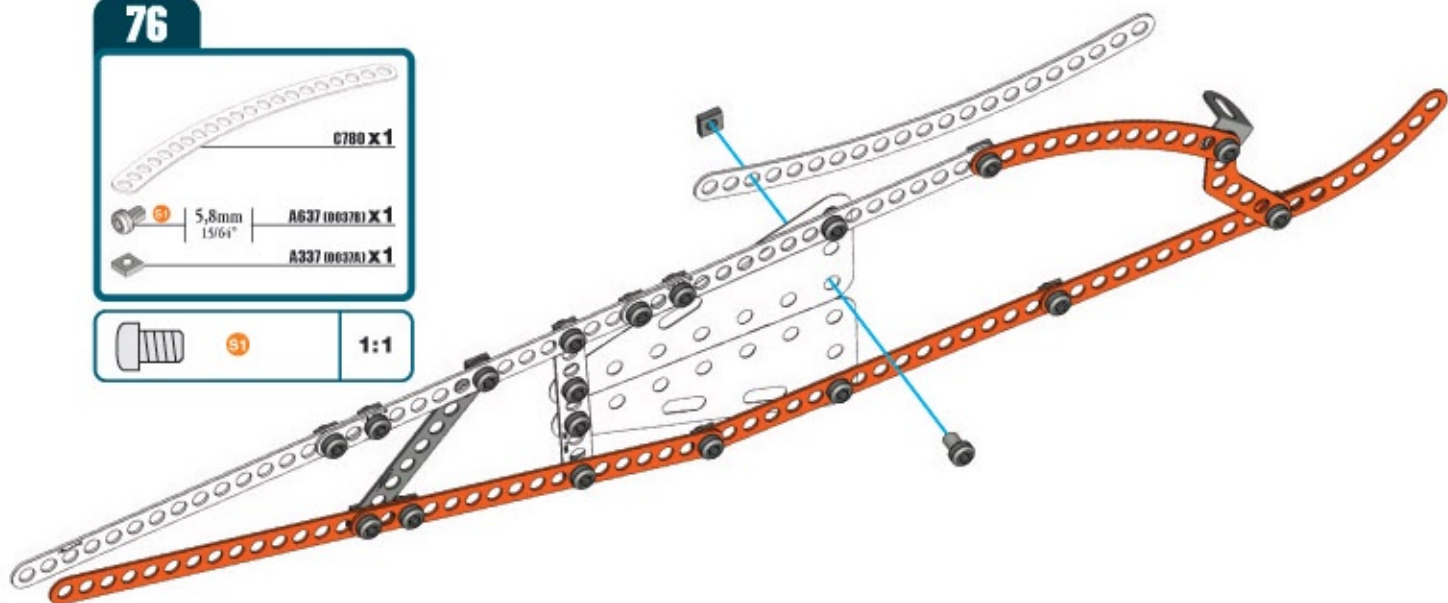
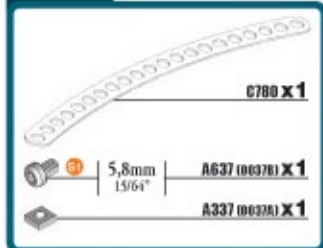
74**75****76**

77



A012 (10012) X 1

5,8mm
15/64"

A637 (10037) X 1



A337 (10037A) X 1



S1

1:1

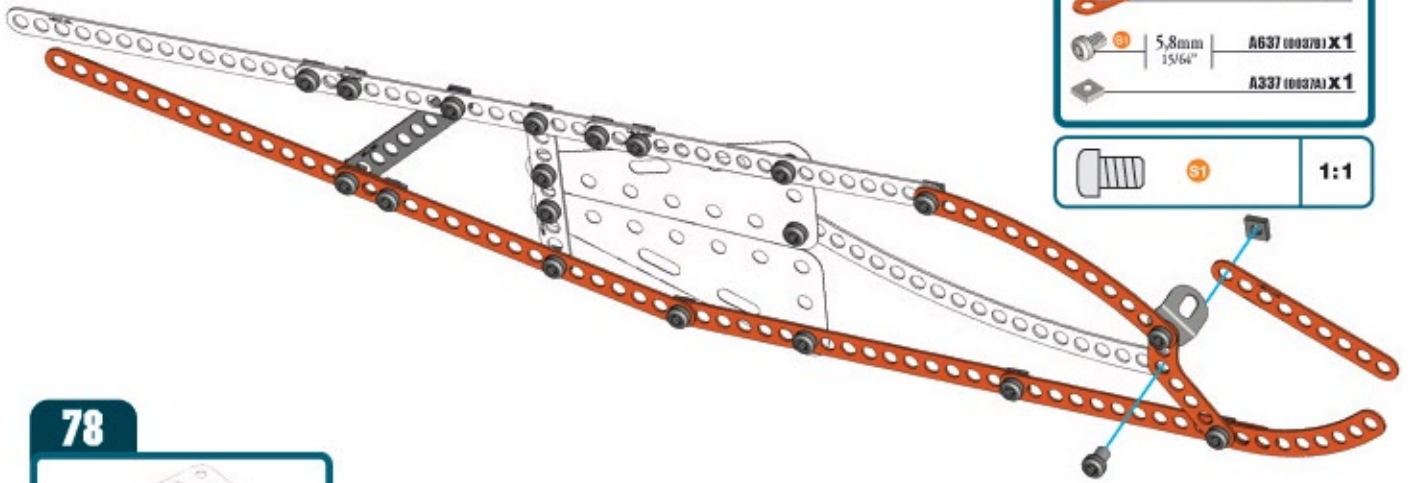

78



A224 (10224) X 1

5,8mm
15/64"

A637 (10037) X 1



A337 (10037A) X 1



S1

1:1

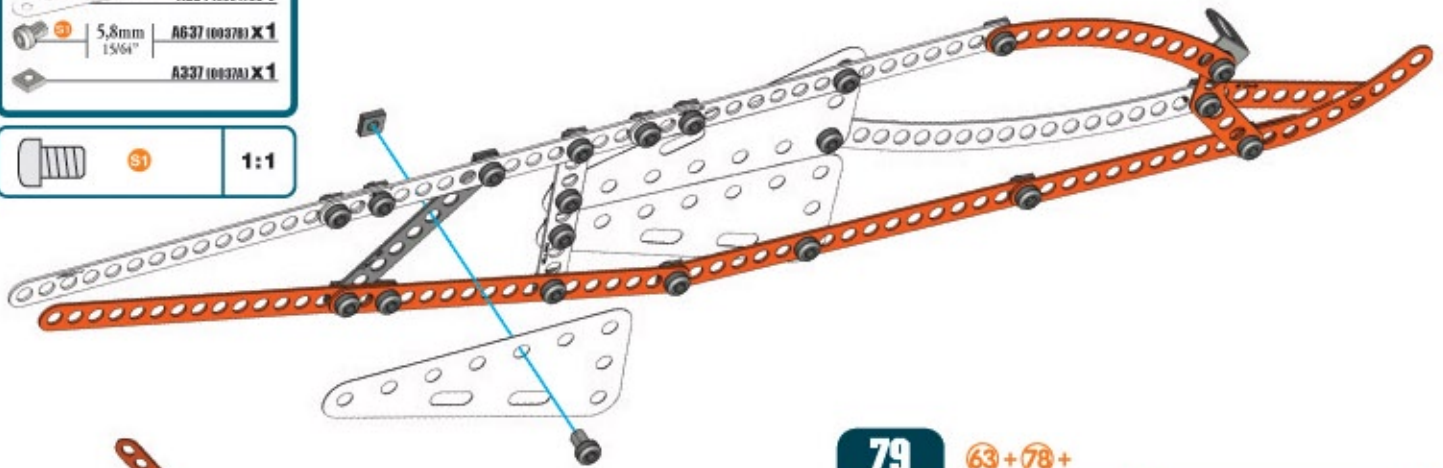

79

63 + 78 +



A238 (10038A) X 2

12mm
1/2"

A411 (10111A) X 2



A337 (10037A) X 2



S3



A238

1:1

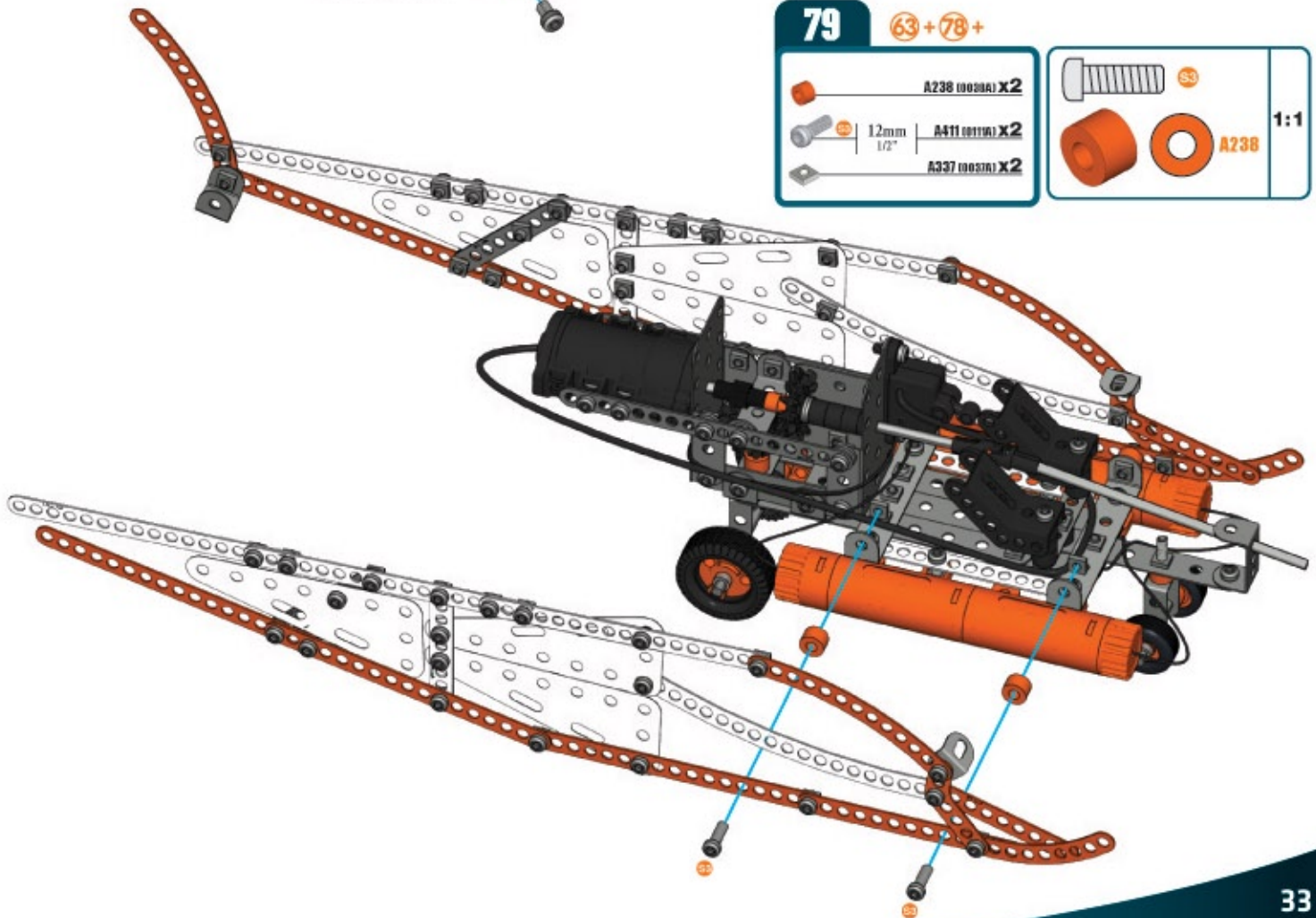

80



A779 x 1



5,8mm
15/64"

A637 (00370) x 1



A337 (00370A) x 1



S1

1:1

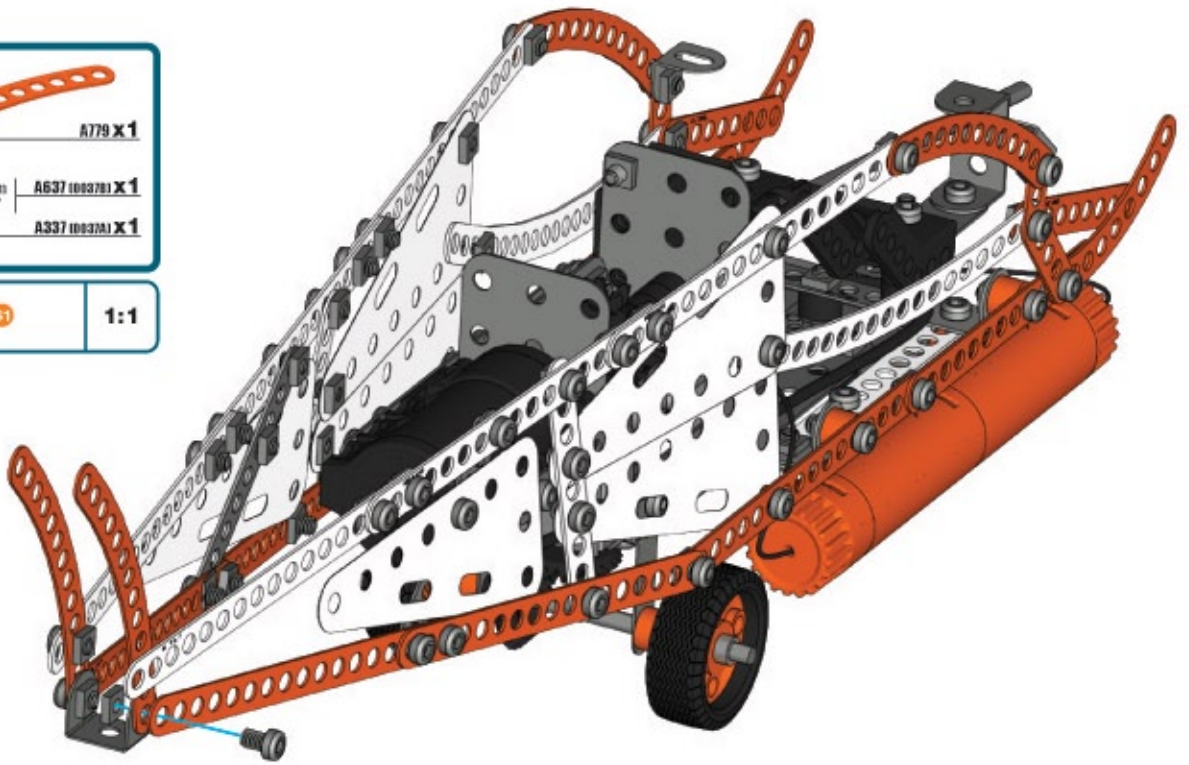

81



5,8mm
15/64"

A637 (00370) x 1



A337 (00370A) x 1



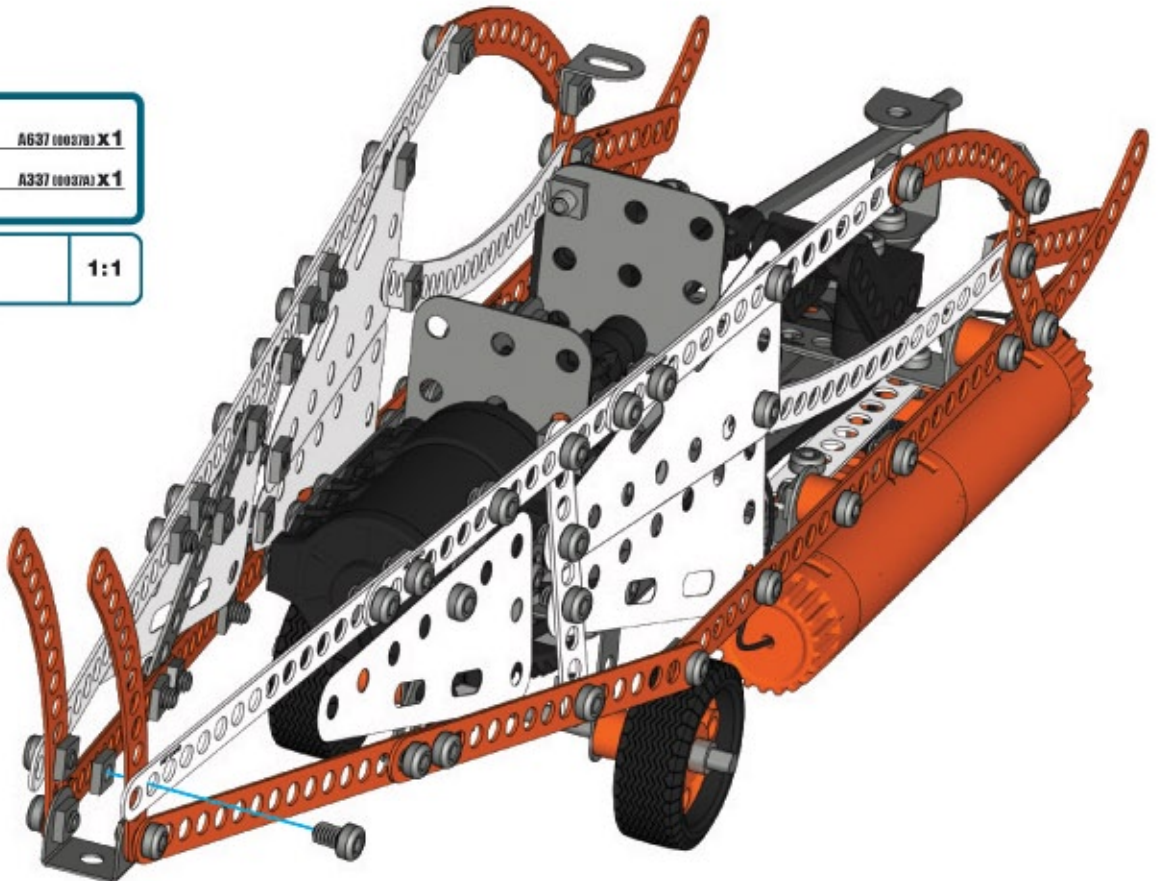

S1

1:1





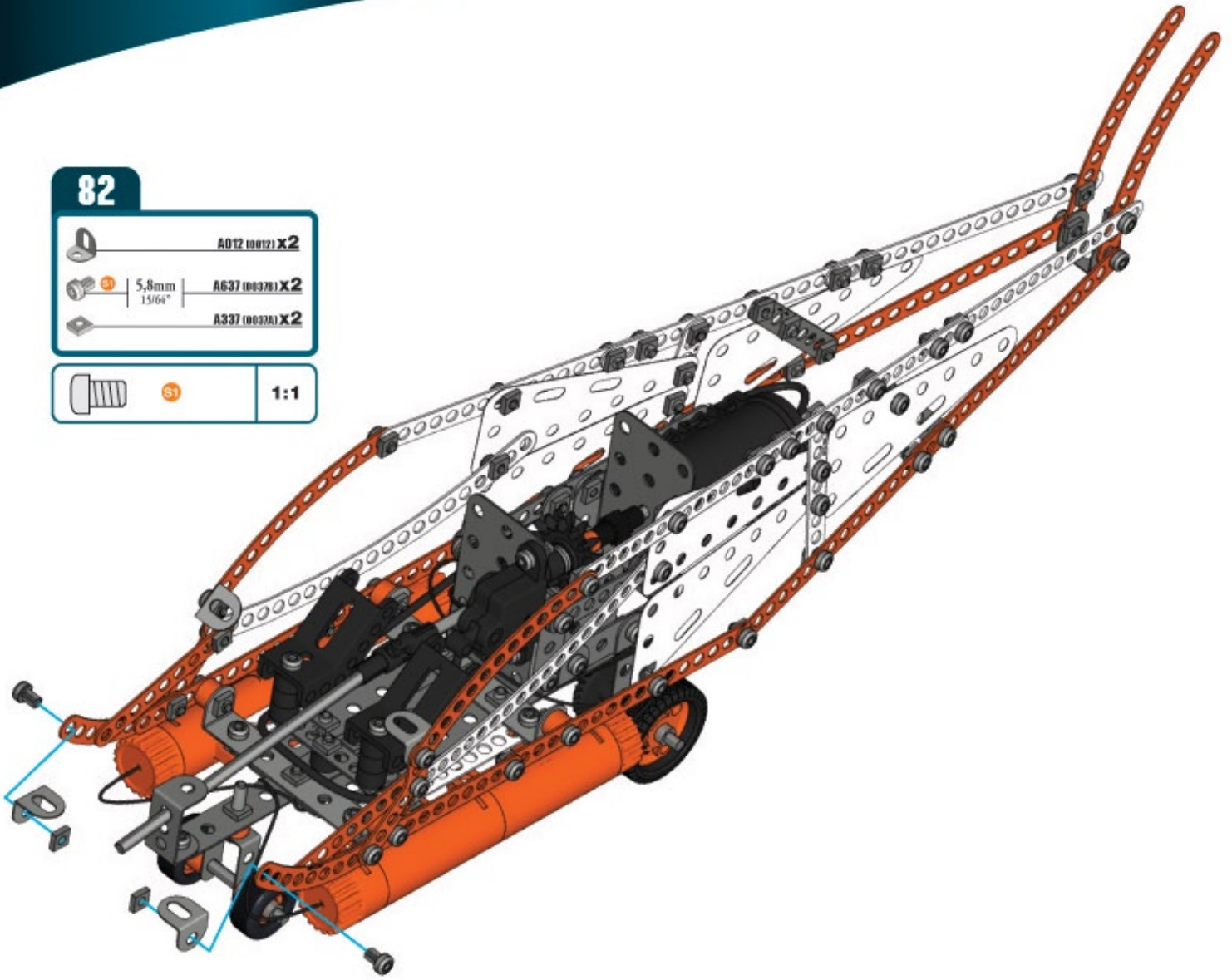

82

-  **A012 (0012) x2**
-  **5,8mm | 15/64"** **A637 (0037B) x2**
-  **A337 (0037A) x2**

-  **S1** **1:1**

**83**

-  **C777 x1**
-  **A520 (0100) x1**
-  **5,8mm | 15/64"** **A637 (0037B) x2**
-  **A337 (0037A) x2**

-  **S1** **1:1**

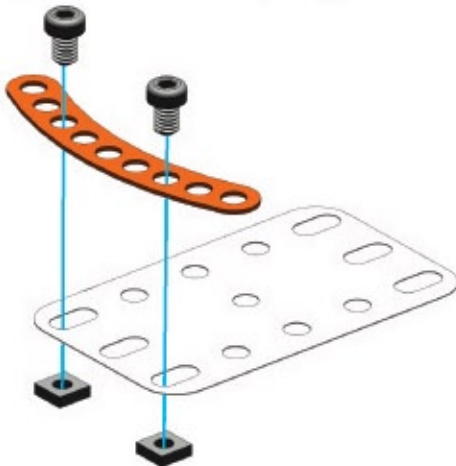

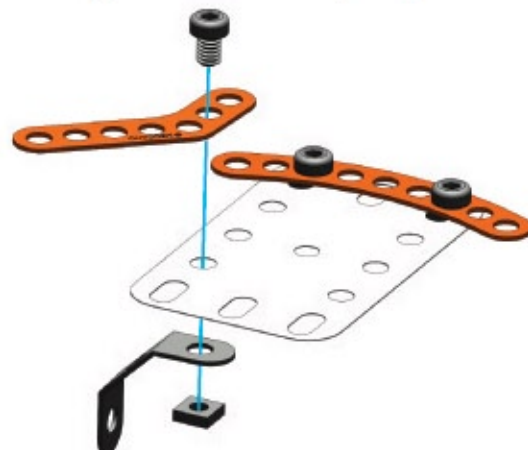

**84**

-  **C776 x1**
-  **C331 x1**
-  **5,8mm | 15/64"** **A637 (0037B) x1**
-  **A337 (0037A) x1**

-  **S1** **1:1**



85

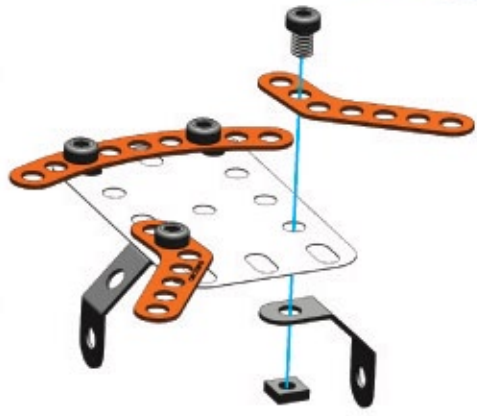

-  **0775 X1**
-  **0331 X1**
-  **5,8mm | A637 (00370) X1**
-  **A337 (00330) X1**

 **ST** | **1:1**



86



82 + 85 +

-  **5,8mm | A637 (00370) X2**
-  **A337 (00330) X2**

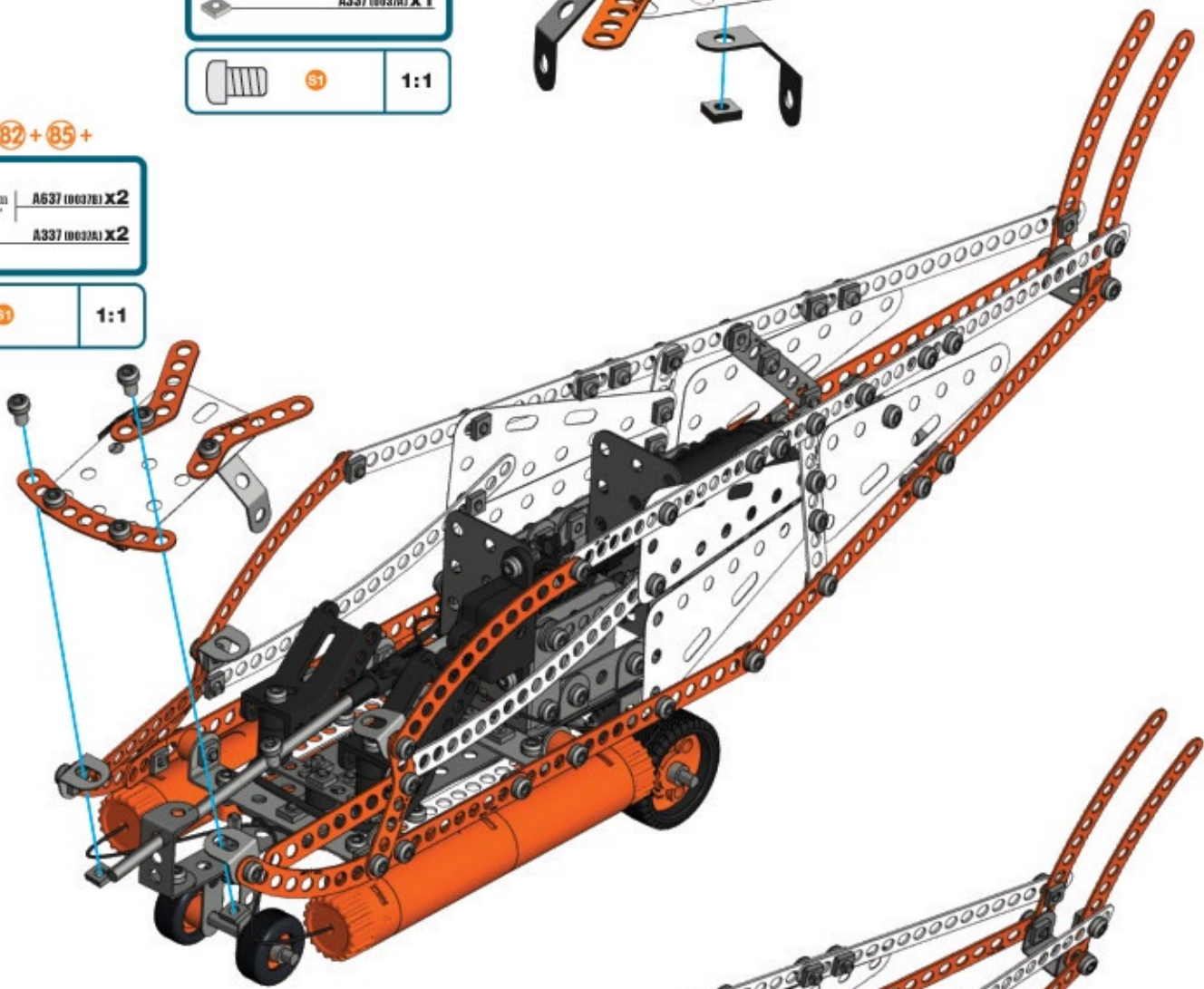
 **ST** | **1:1**





87

-  **5,8mm | A637 (00370) X2**
-  **A337 (00330) X2**

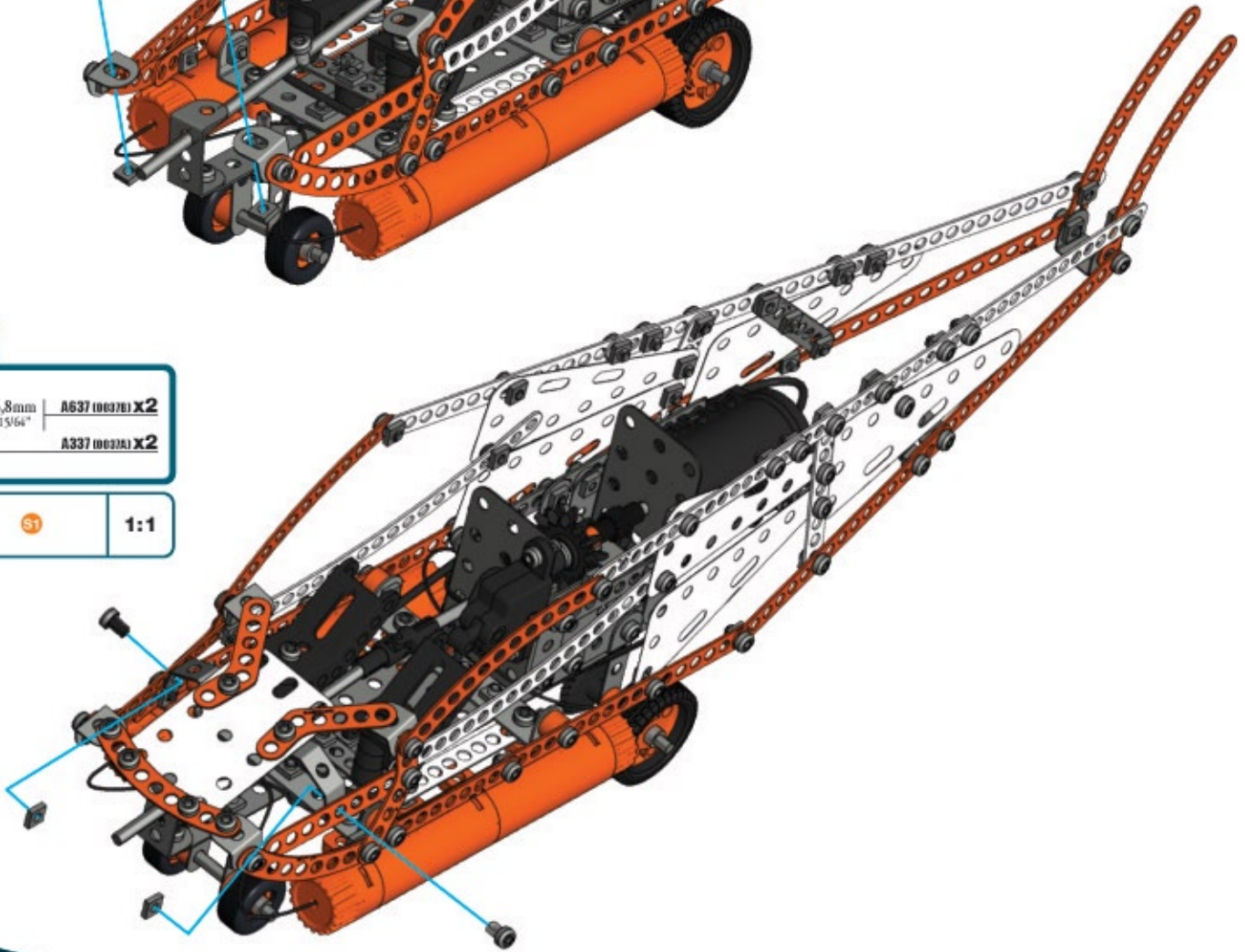
 **ST** | **1:1**





88

 5.8mm | A637 (00376) X2
 A337 (00370) X2

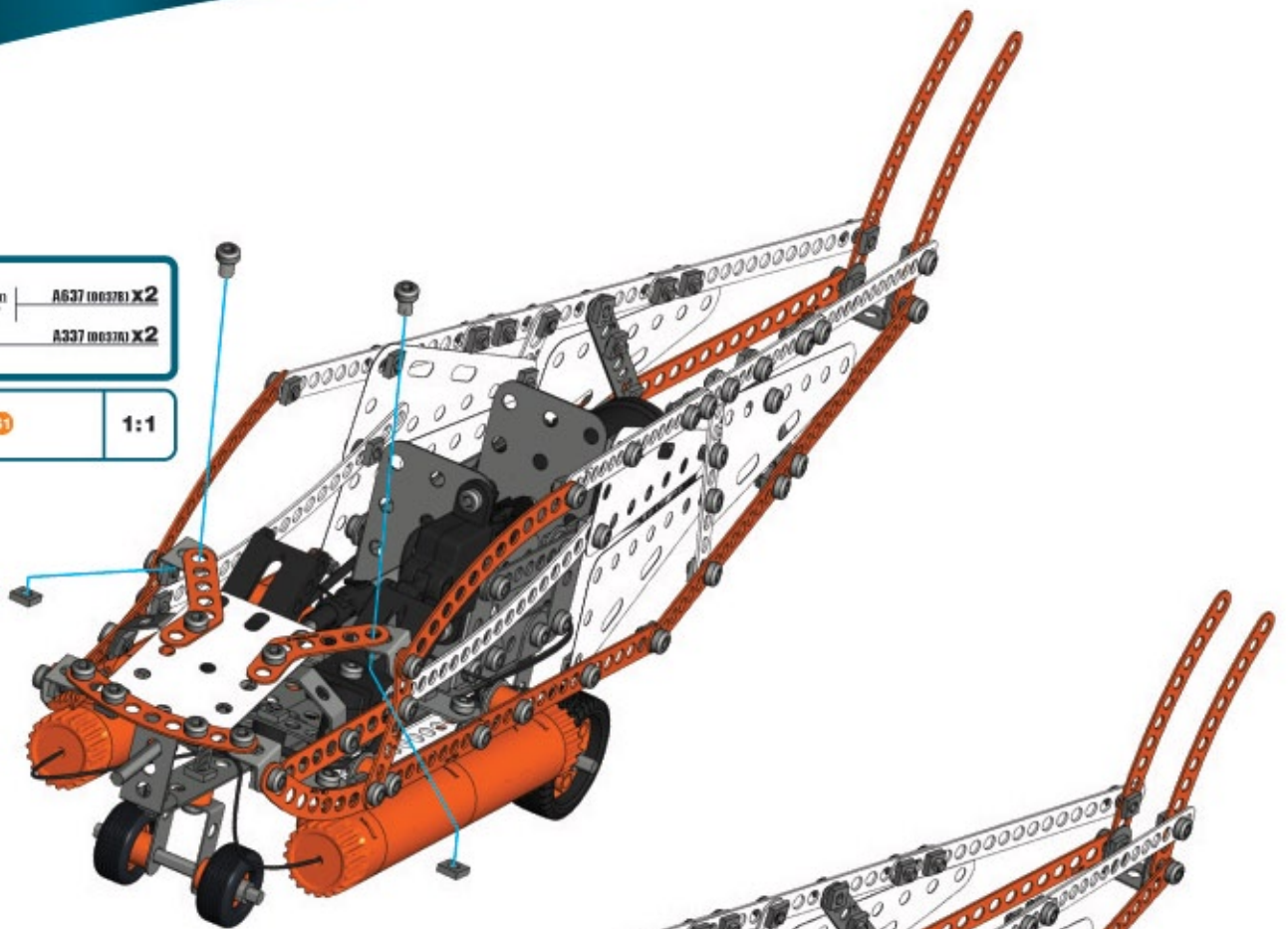
 S1 | 1:1



89

 C771 X1
 A238 (0038A) X2
 A259 (00580) X1

 A238 | 1:1

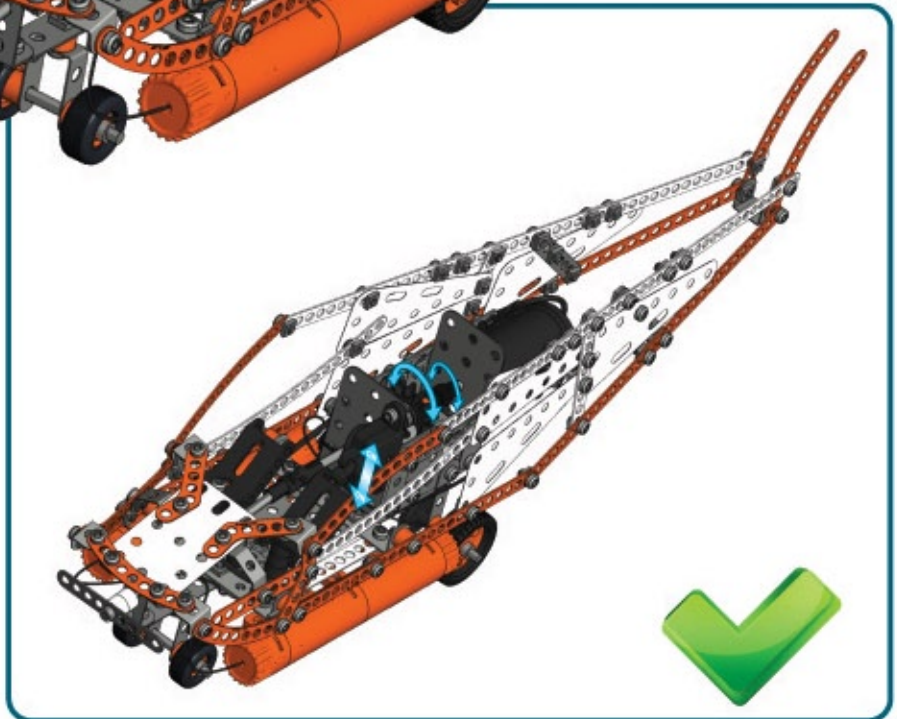
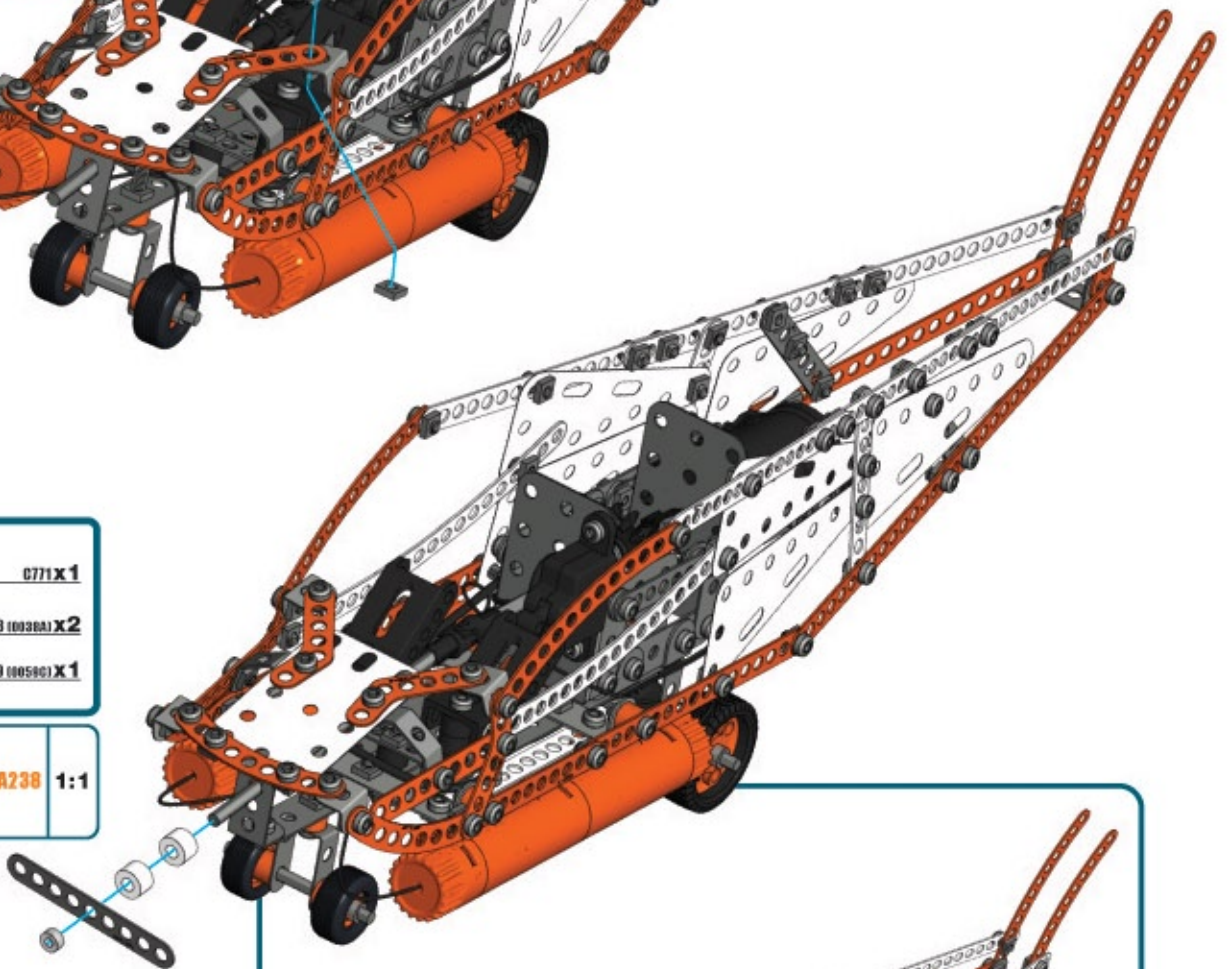

90

- A512 (100120) X2
- 5,8mm 15/64" A637 (100370) X2
- A337 (100370) X2

		1:1
---	---	-----

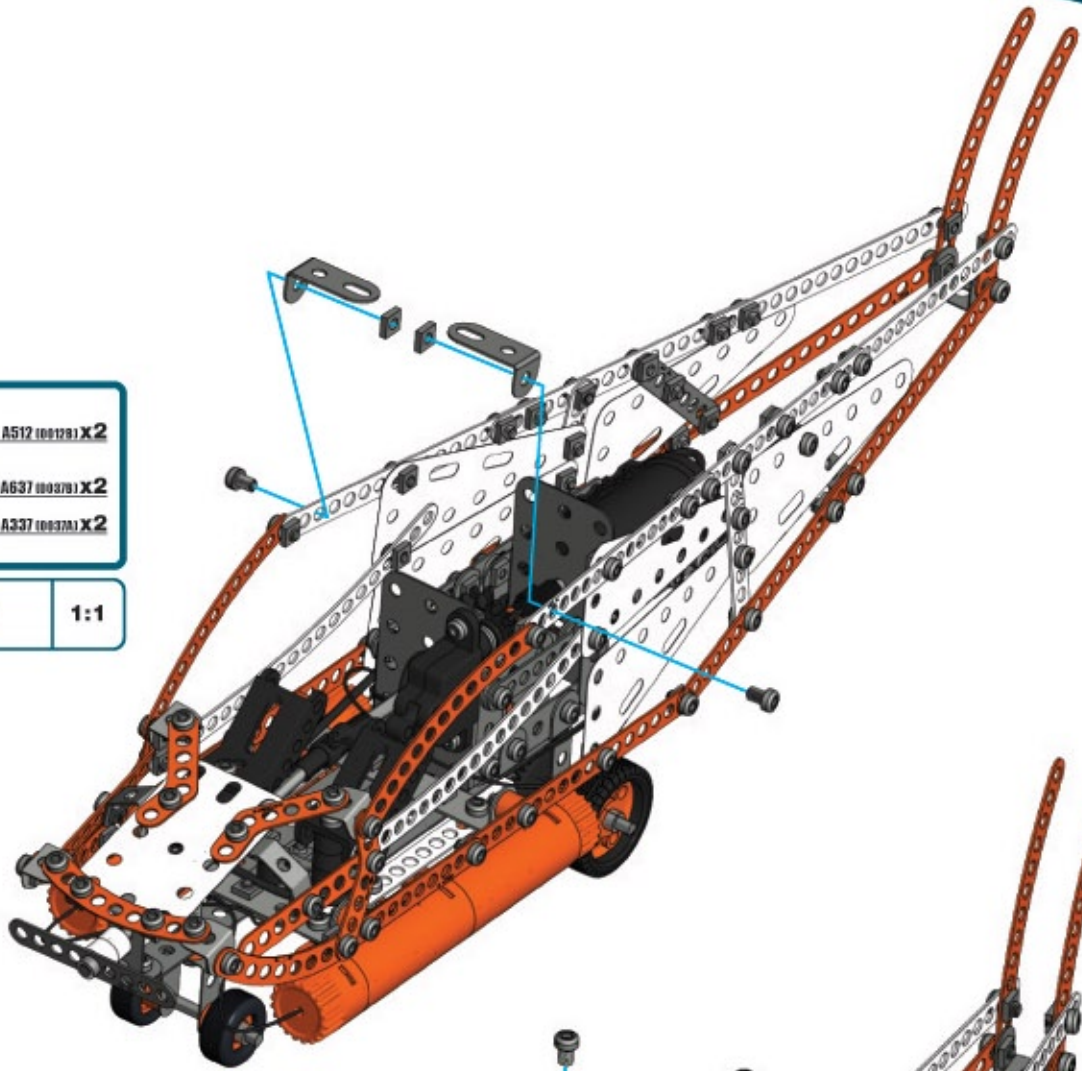

91

- A520 (10190) X1
- 5,8mm 15/64" A637 (100370) X2
- A337 (100370) X2

		1:1
---	---	-----

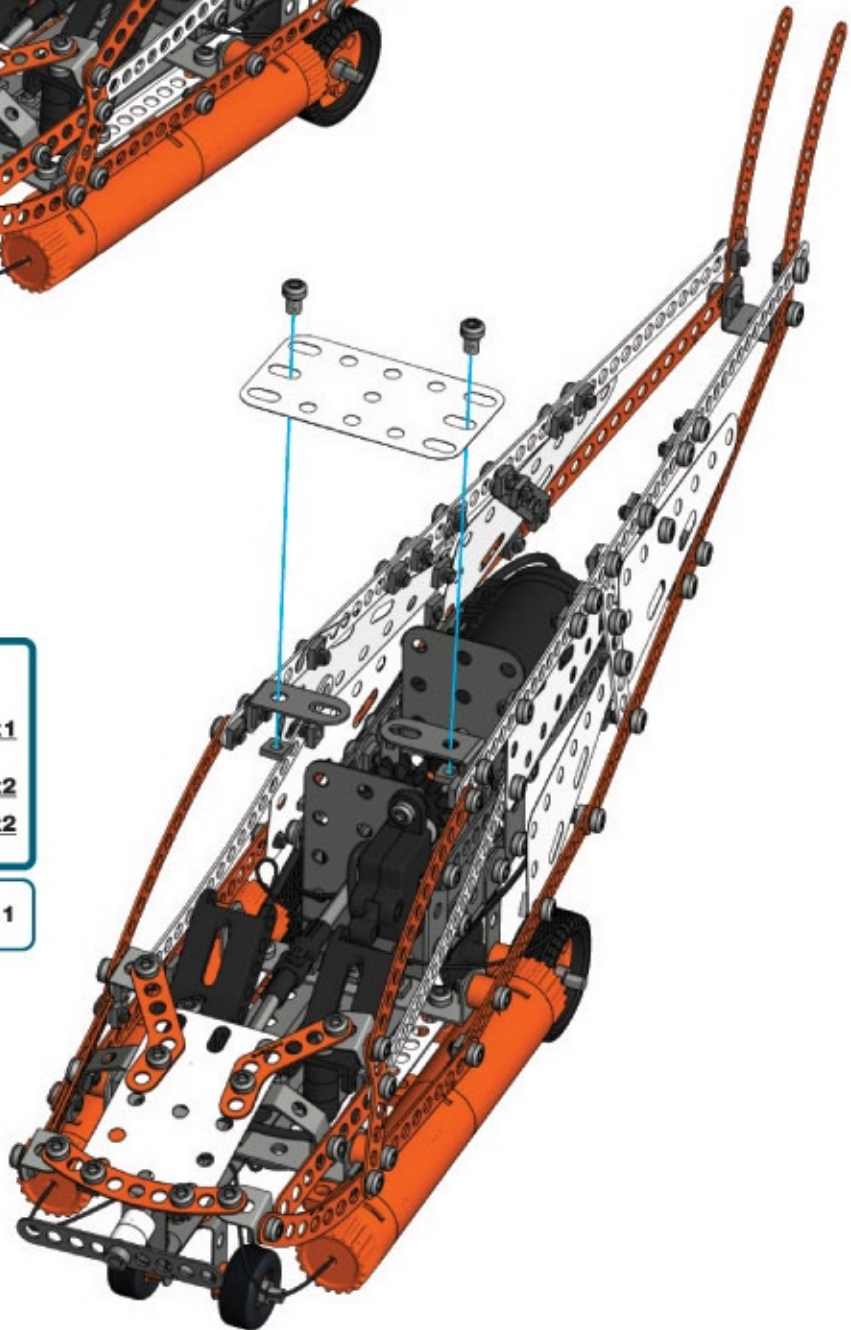

92

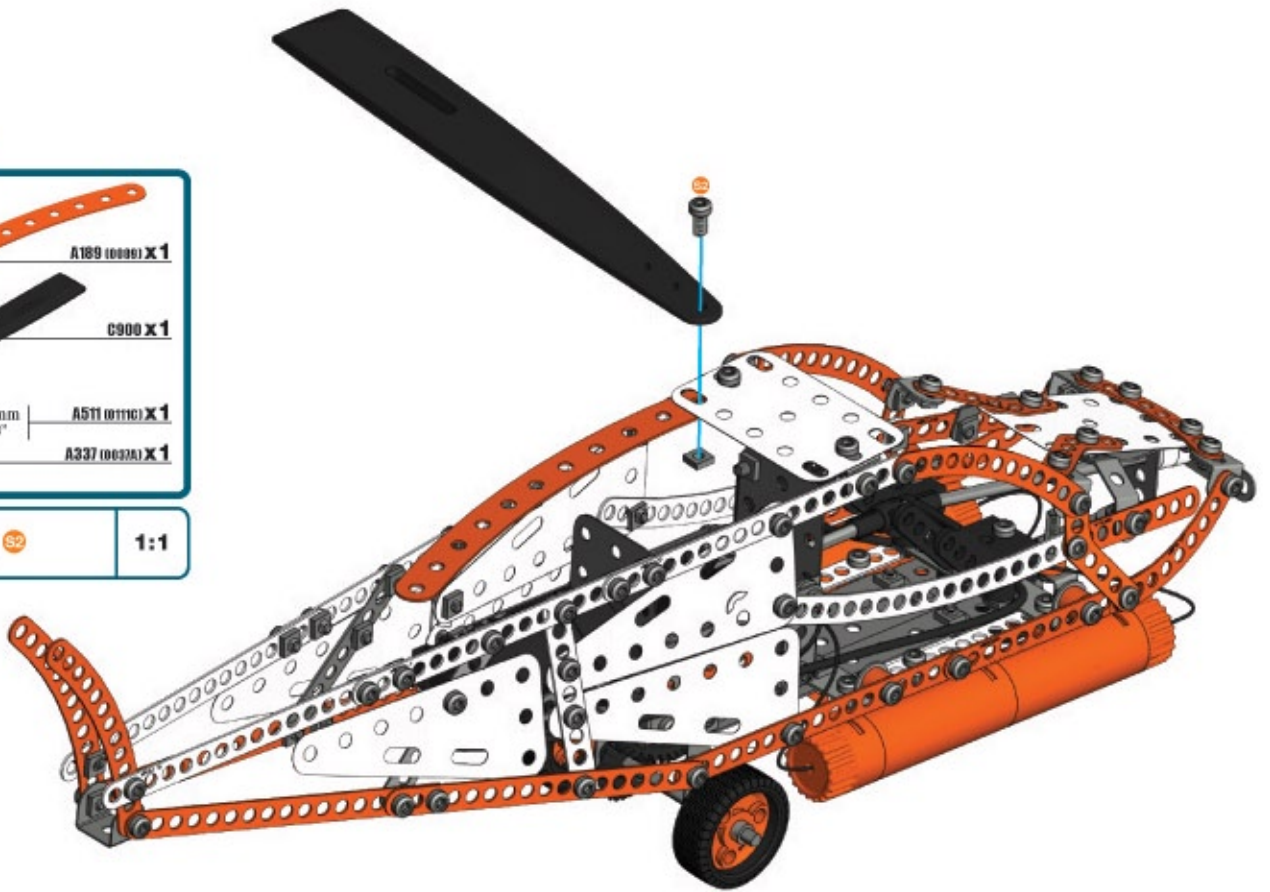

93

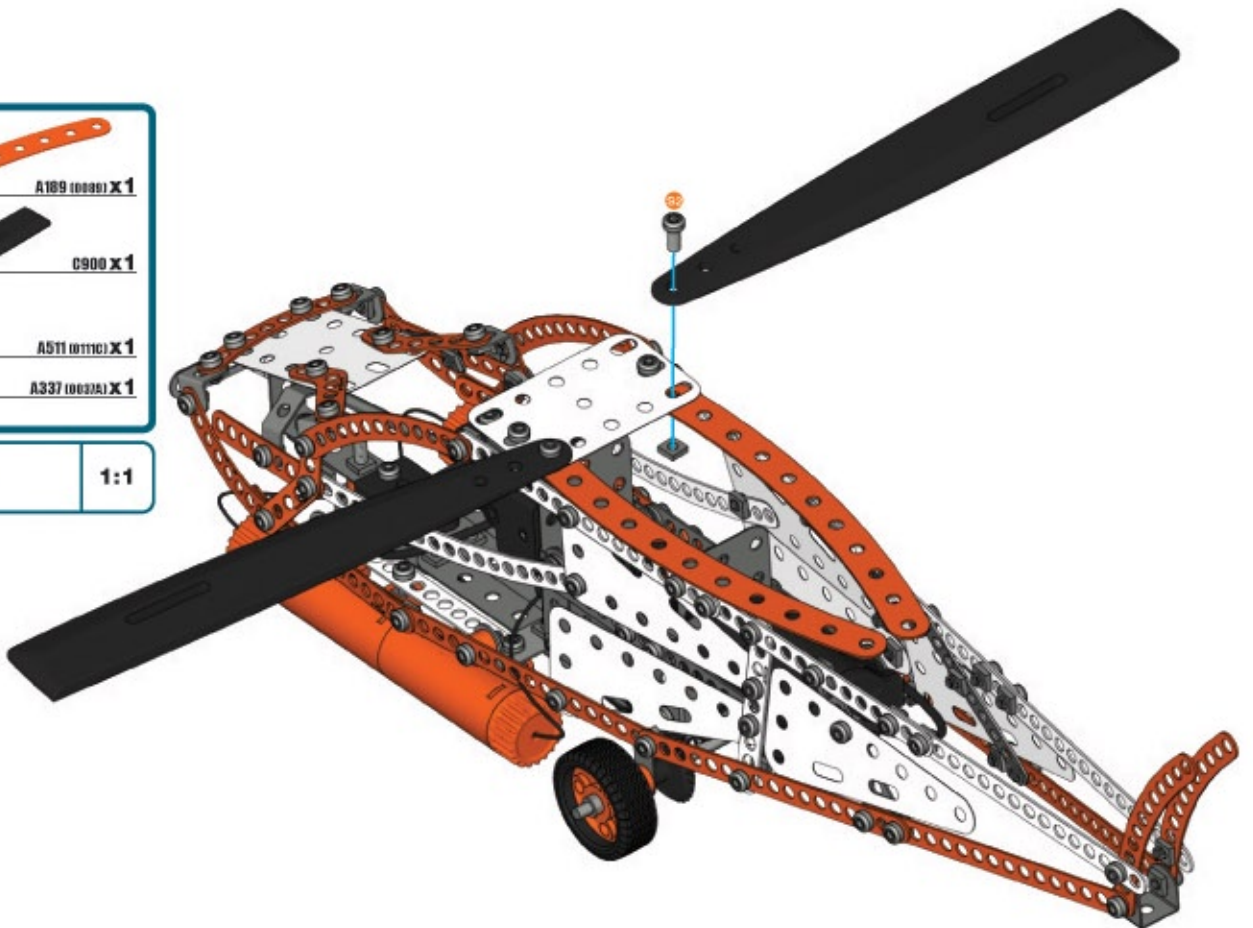



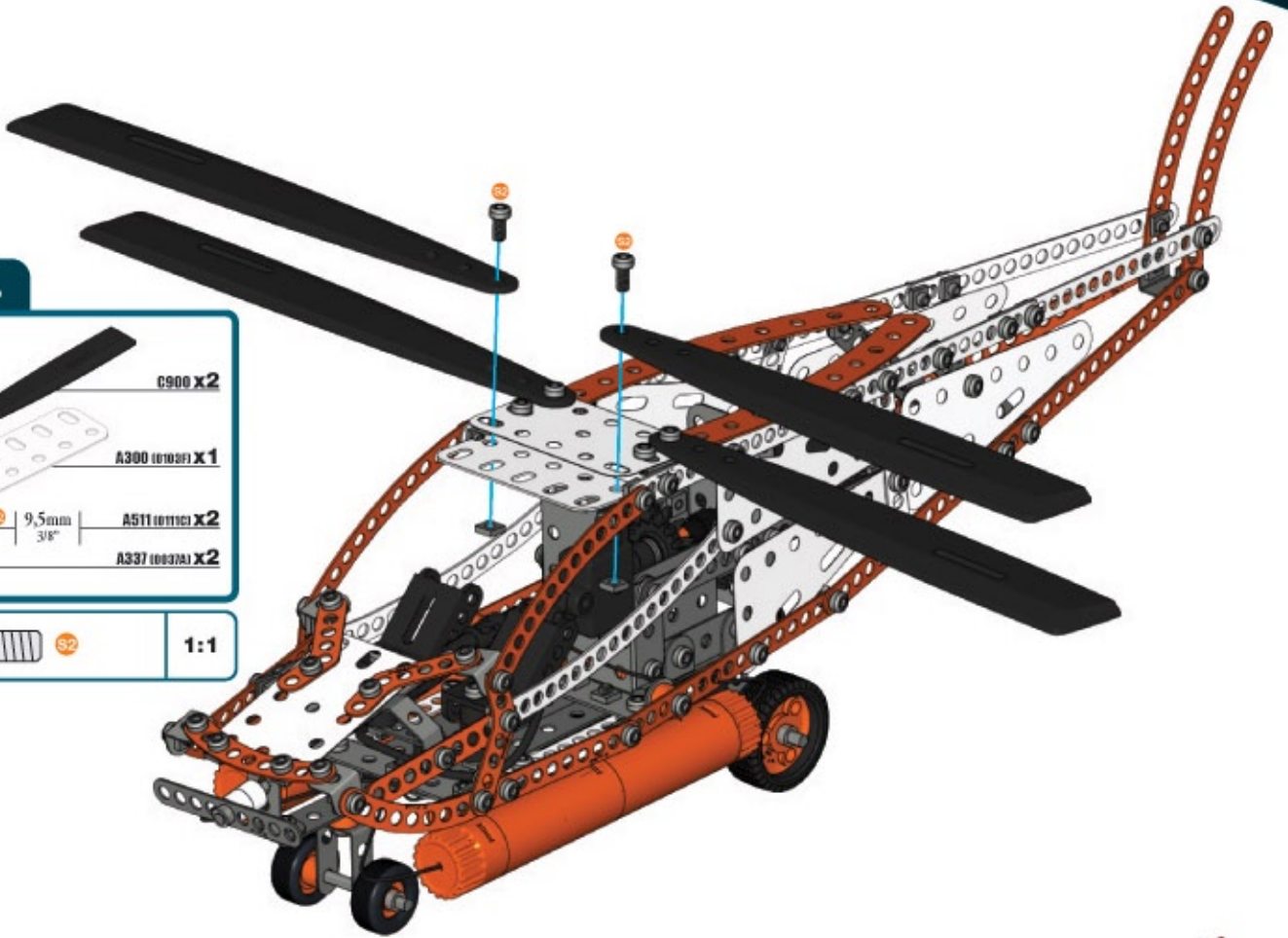

94

-  **C900 x2**
-  **A300 (010201) x1**
-  **A511 (011101) x2**
-  **A337 (003701) x2**

 **S2** | **1:1**



95

-  **G776 x1**
-  **A411 (011101) x1**
-  **A511 (011101) x1**
-  **A337 (003701) x2**

 **S3**
 **S2** | **1:1**

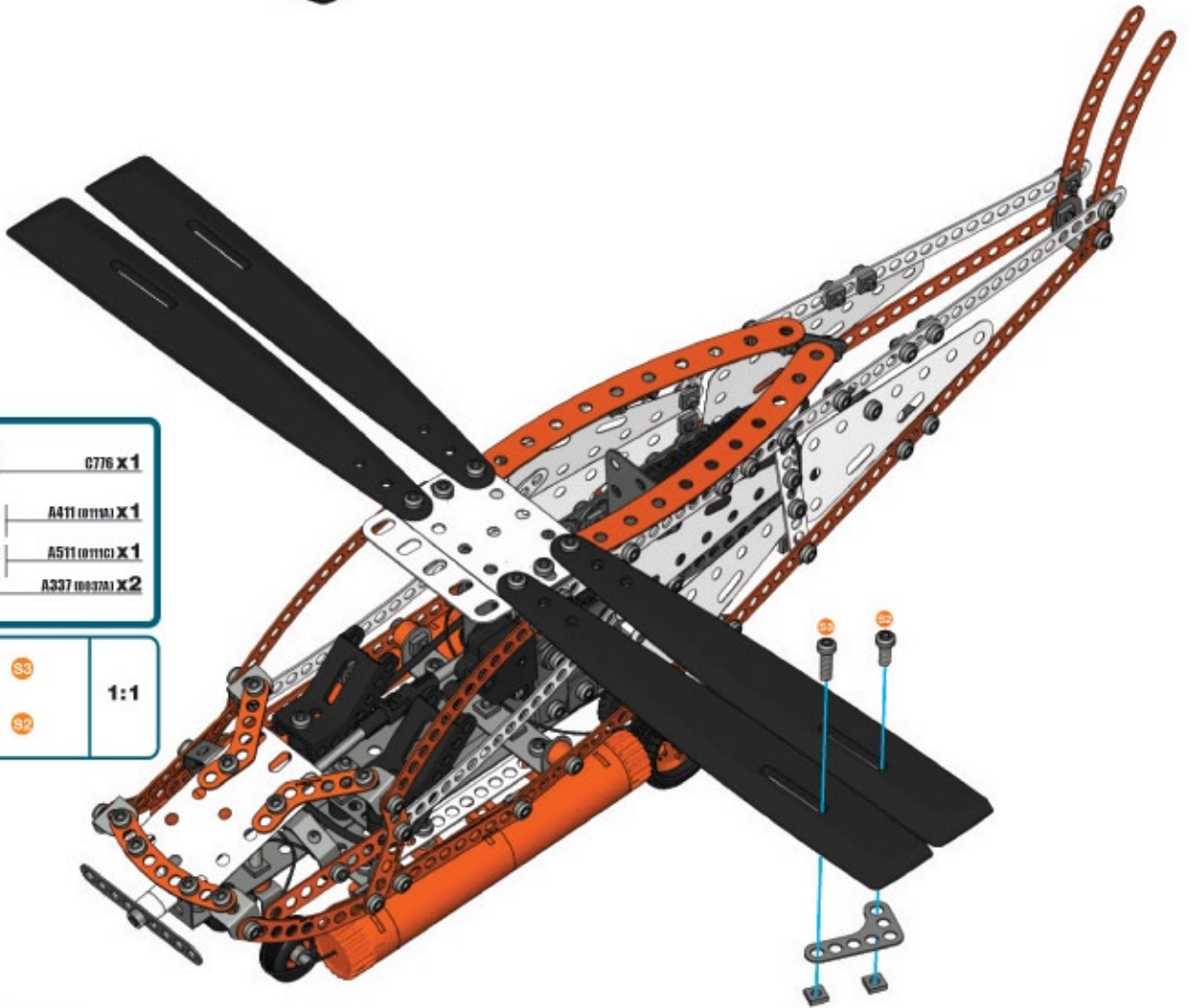

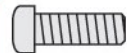
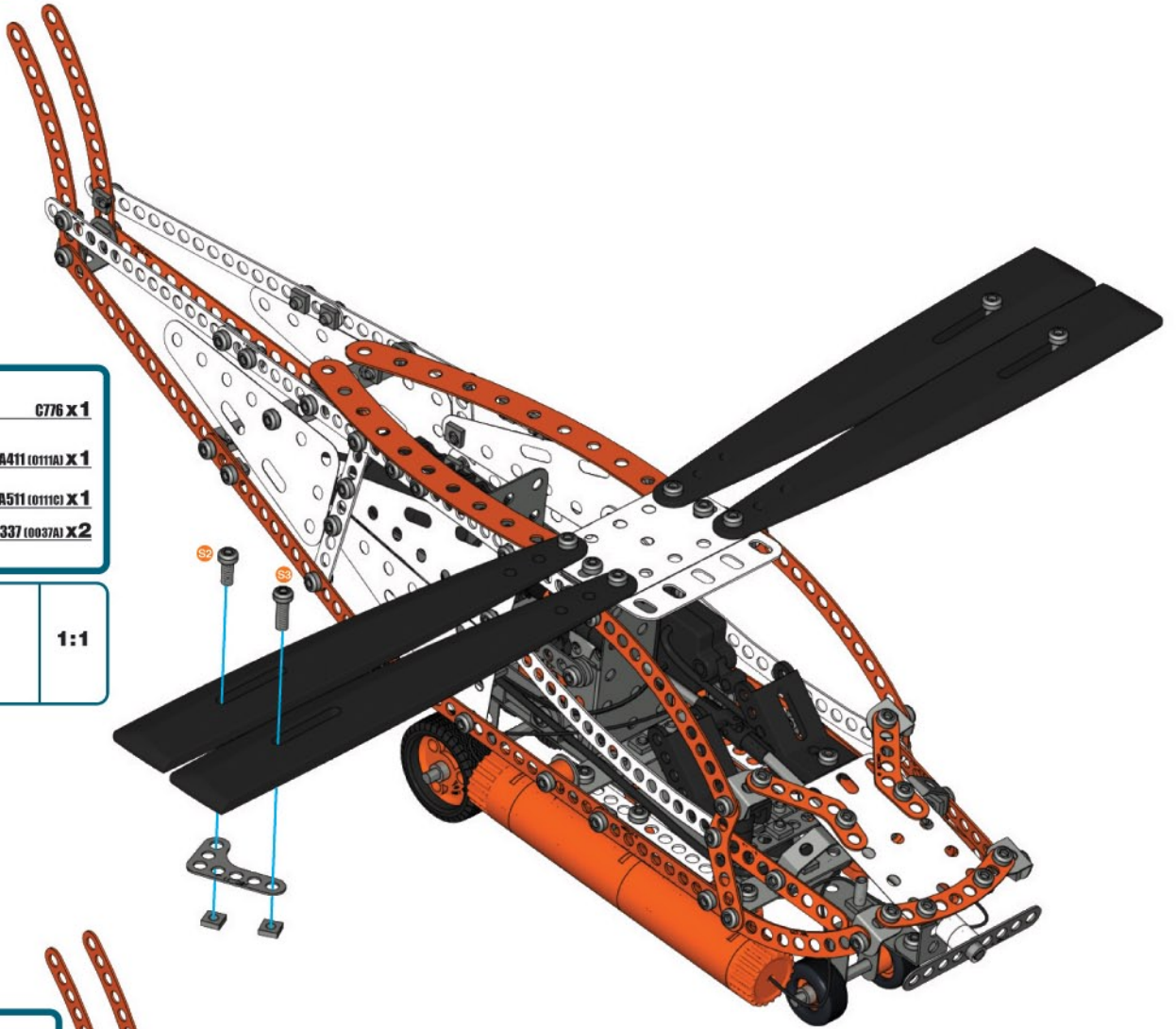
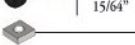
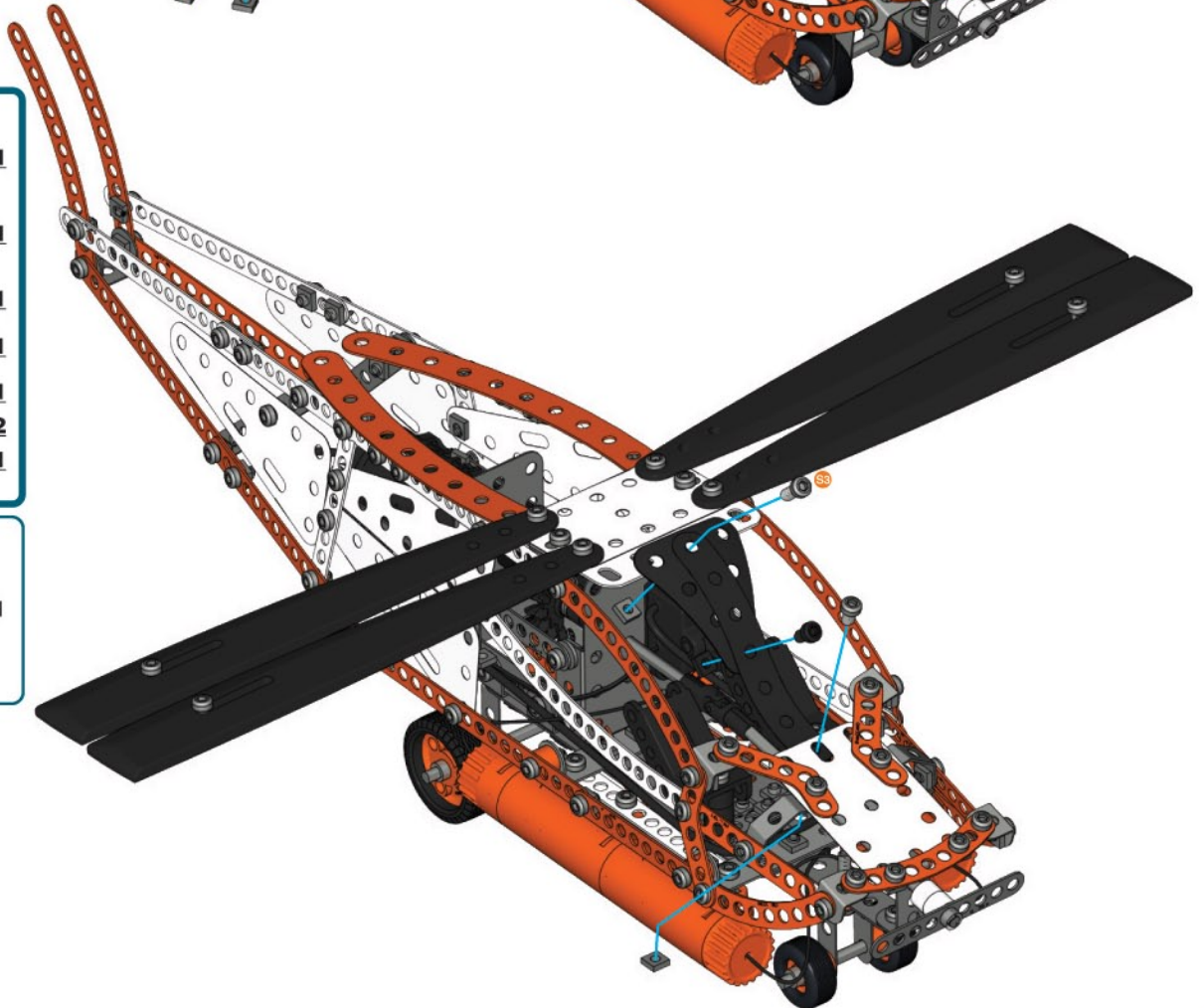
96**C776 x 1**12mm
1/2"**A411 (0111A) x 1**9,5mm
3/8"**A511 (0111C) x 1****A337 (0037A) x 2****S3****S2****1:1****97****B488 x 1****B695 x 1**12mm
1/2"**A411 (0111A) x 1**5,8mm
15/64"**A637 (0037B) x 1**5,8mm
15/64"**A637 (0037B) x 1****A337 (0037A) x 2****A337 (0037A) x 1****S3****S1****S1****1:1**

98



C774 X1

C771 X2

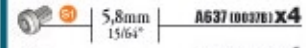

5,8mm
15/64"

A637 (06376) X4

A337 (06376) X4



51

1:1

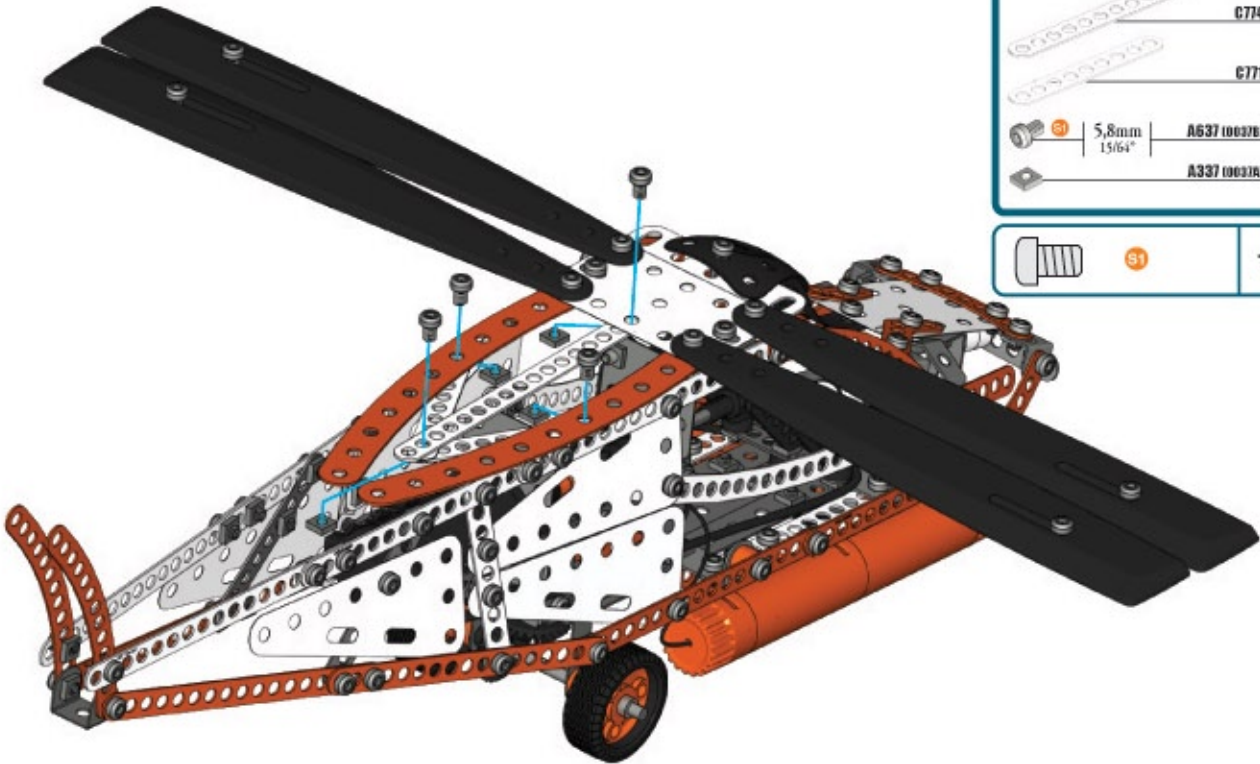

99



C773 X2



A720 (00110) X1



5,8mm
15/64"

A637 (06376) X2

A337 (06376) X2



51

1:1

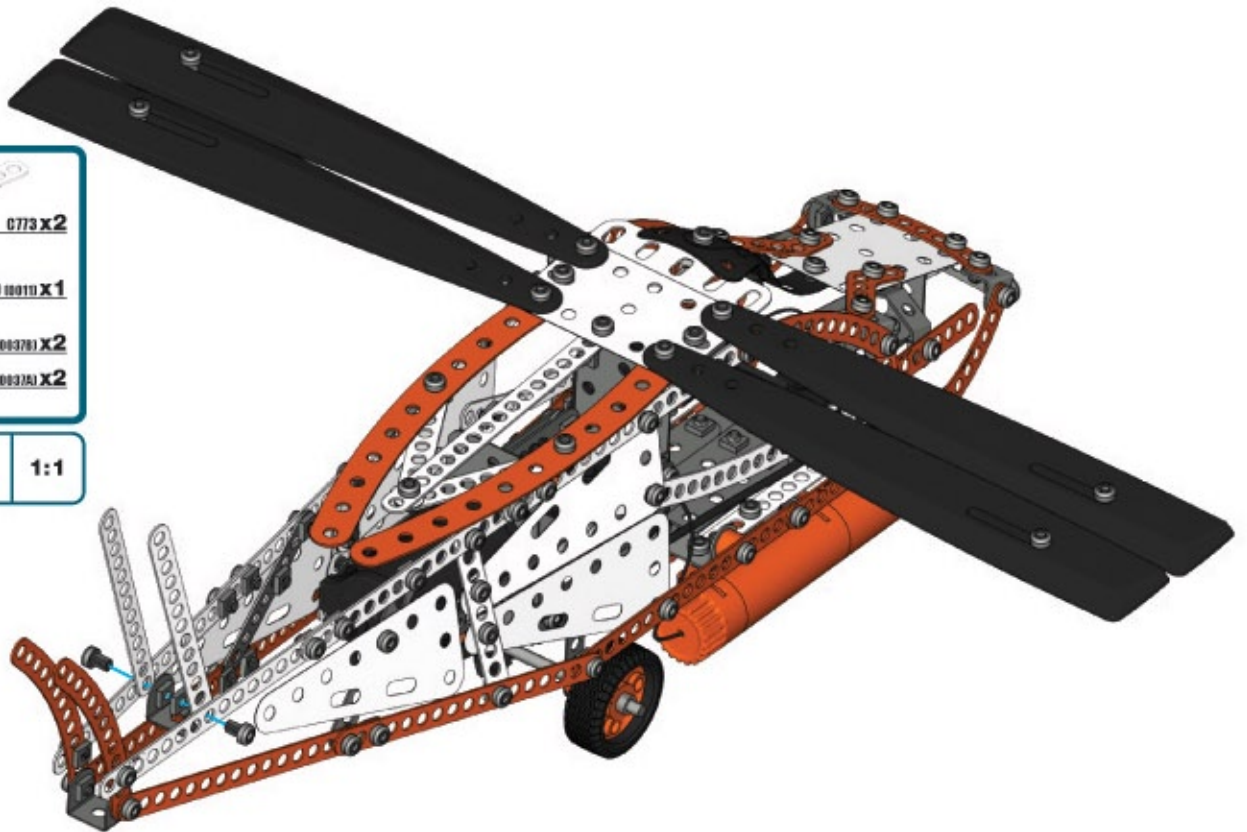

100

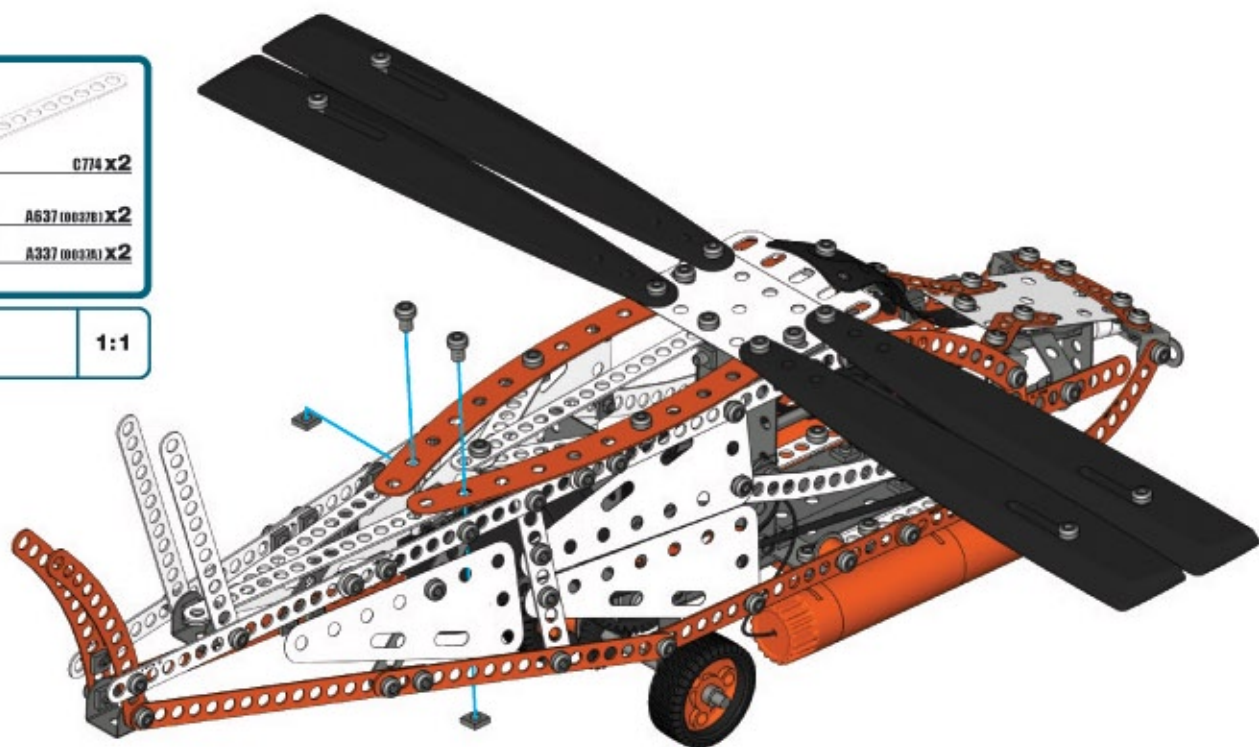
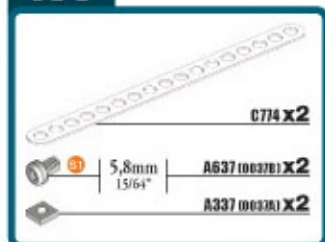



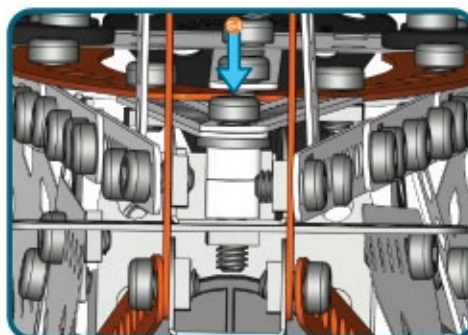
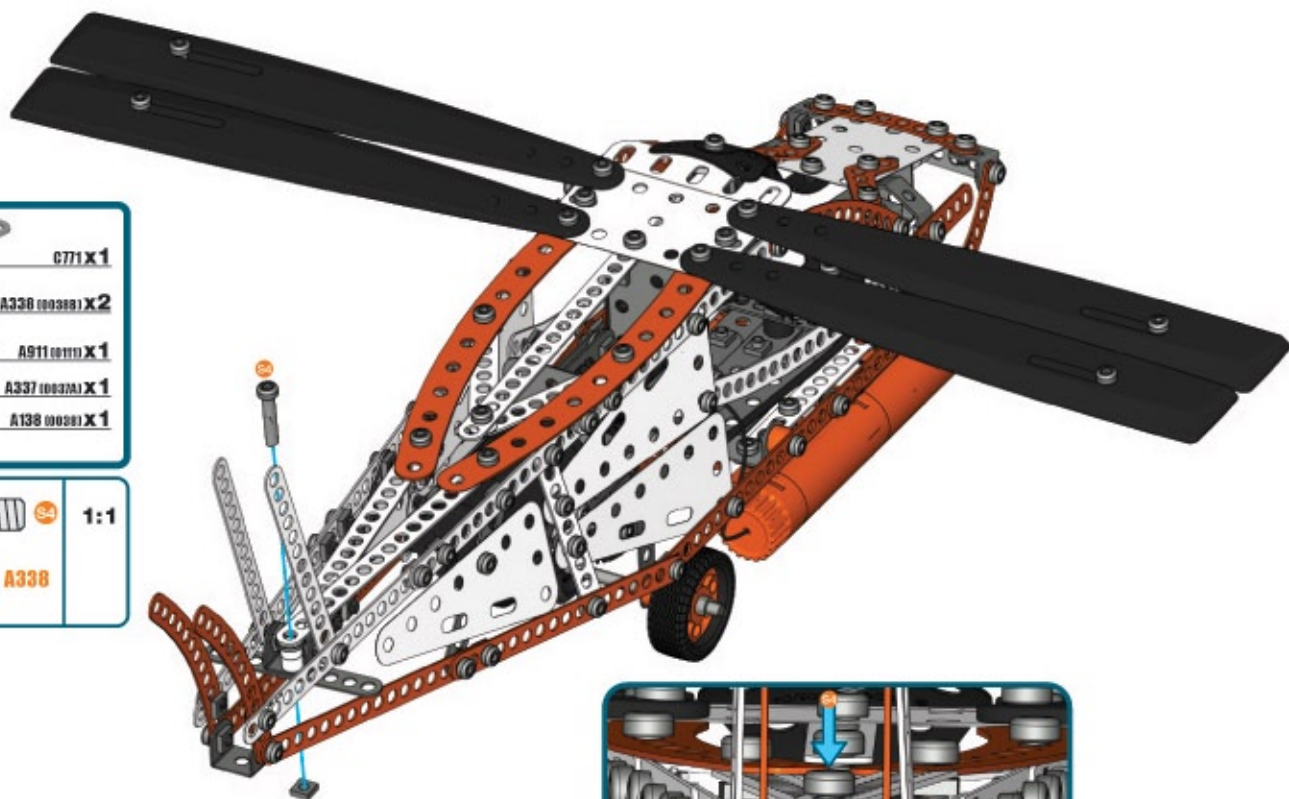

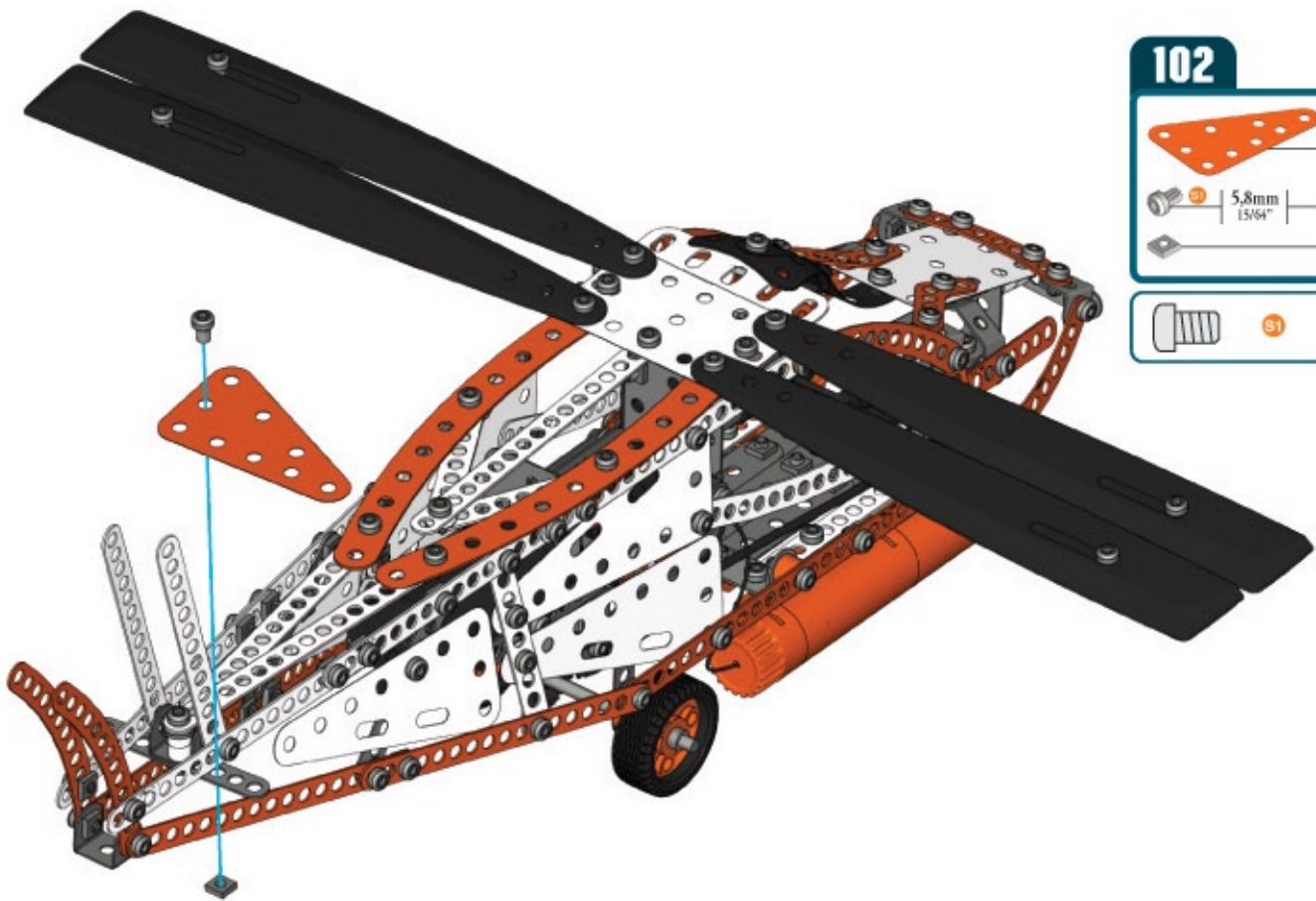
101







102

-  **A221 (00221) X 1**
-  **5,8mm** | **A637 (00378) X 1**
15/64"
-  **A337 (00370) X 1**

	S1	1:1
---	-----------	------------



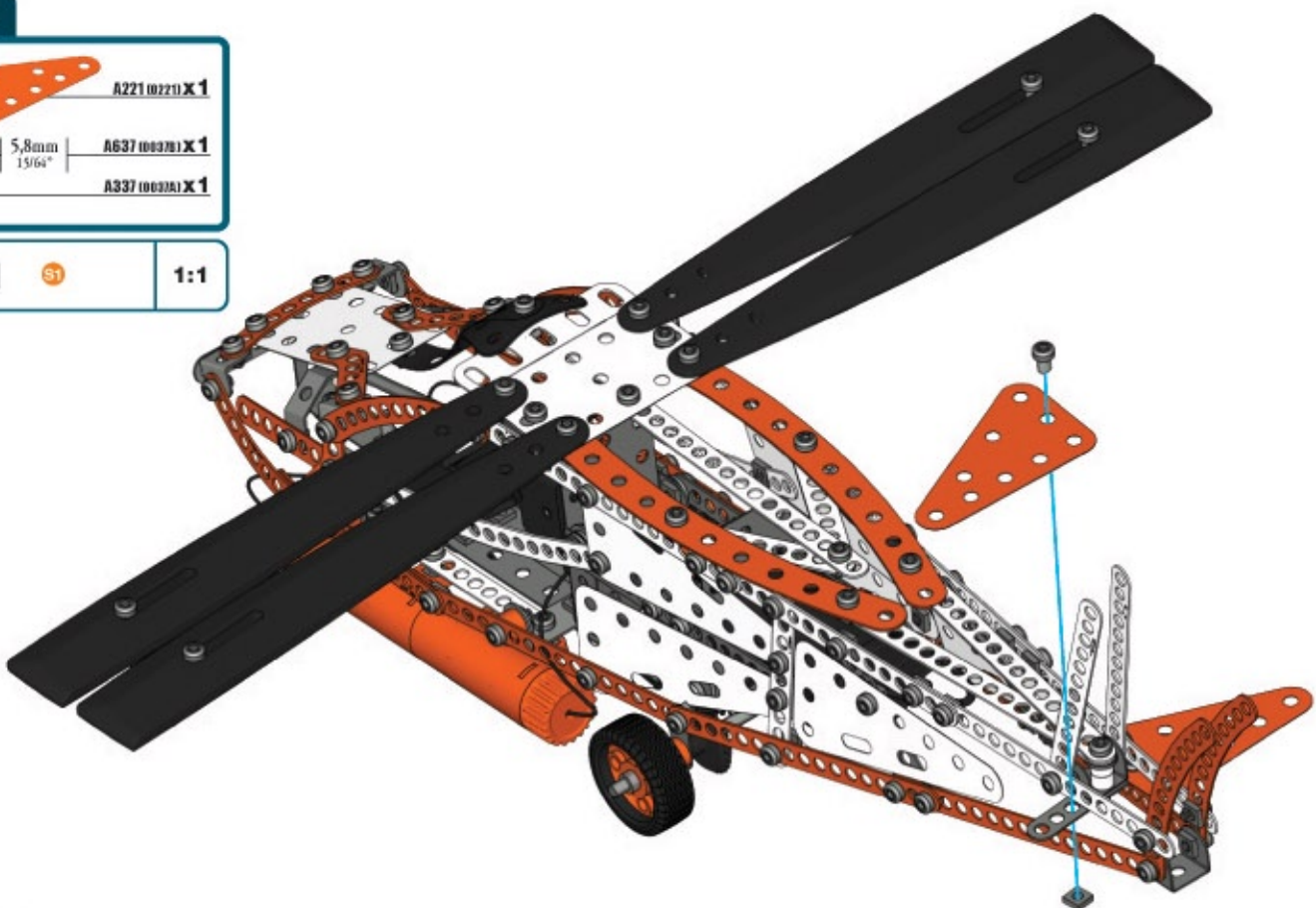

103

-  **A221 (00221) X 1**
-  **5,8mm** | **A637 (00378) X 1**
15/64"
-  **A337 (00370) X 1**

	S1	1:1
---	-----------	------------



104

-  **0768 x 1**
-  **A336 (00030) x 2**
-  **14,2 mm | A247 (01470) x 1**
37/64"
-  **A337 (00030) x 1**

	031	1:1
	A338	

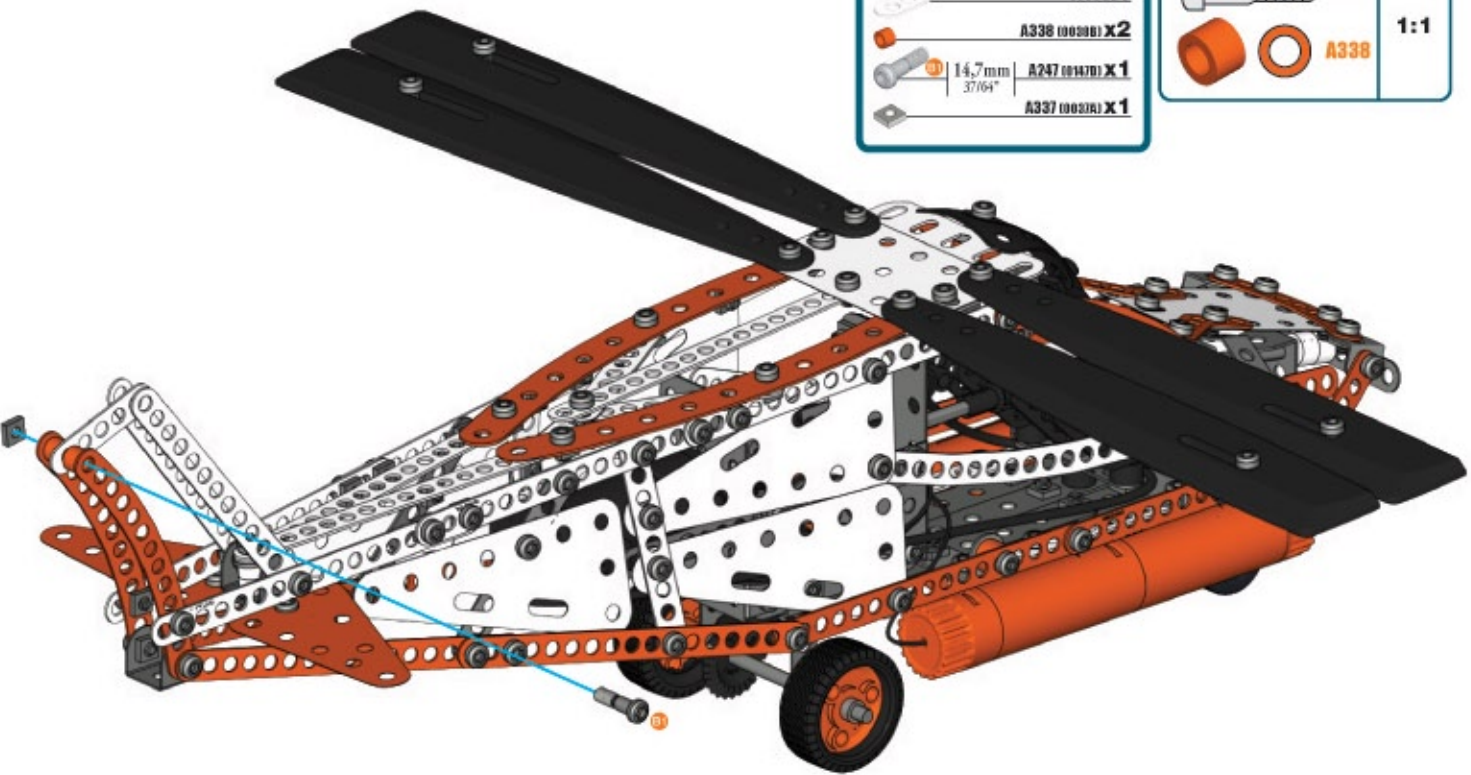

105

-  **12mm | A411 (01110) x 1**
1/2"
-  **A337 (00030) x 1**
-  **A138 (00030) x 4**

	035	1:1
---	------------	------------

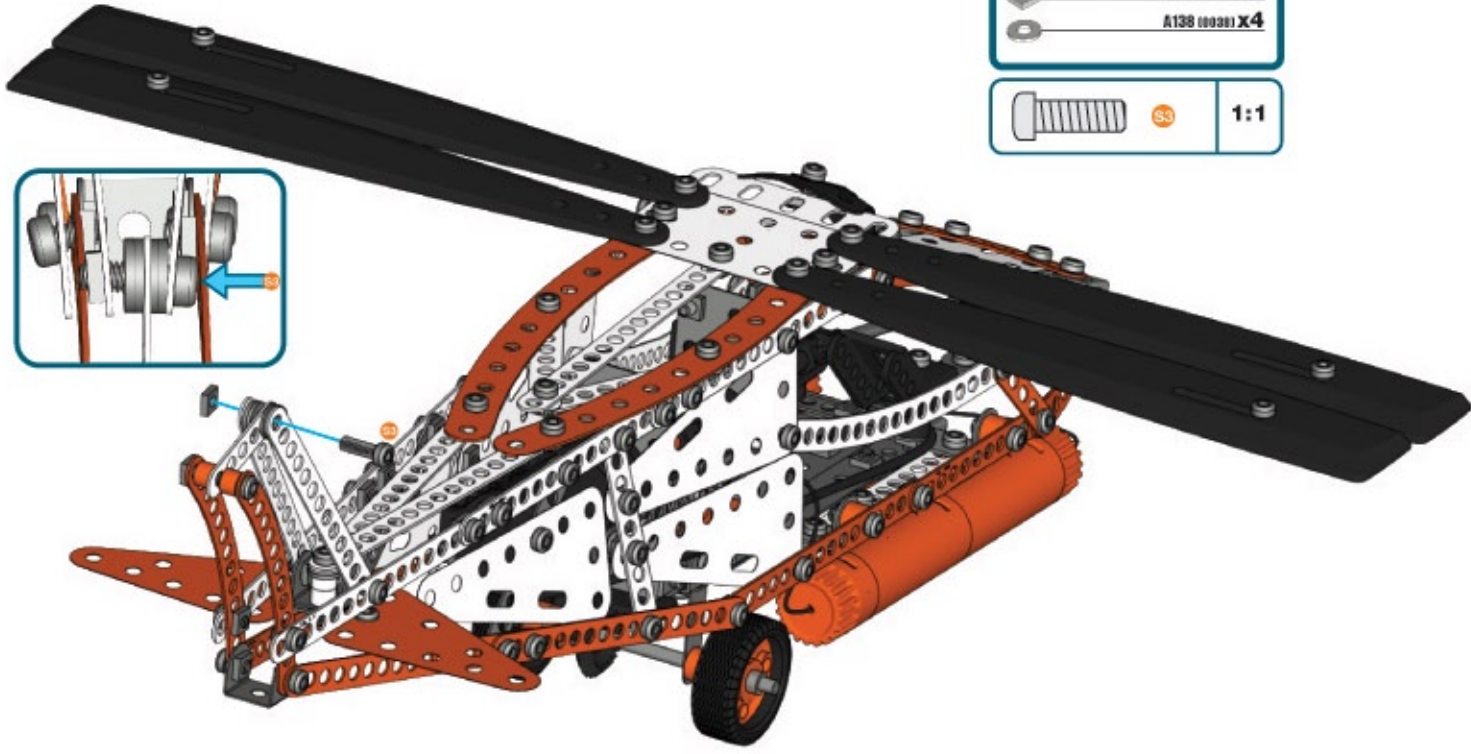
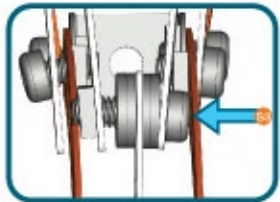



106

	C771 X 1
	A637 (000378) X 1
	A337 (000376) X 1

	S1	1:1
--	-----------	------------

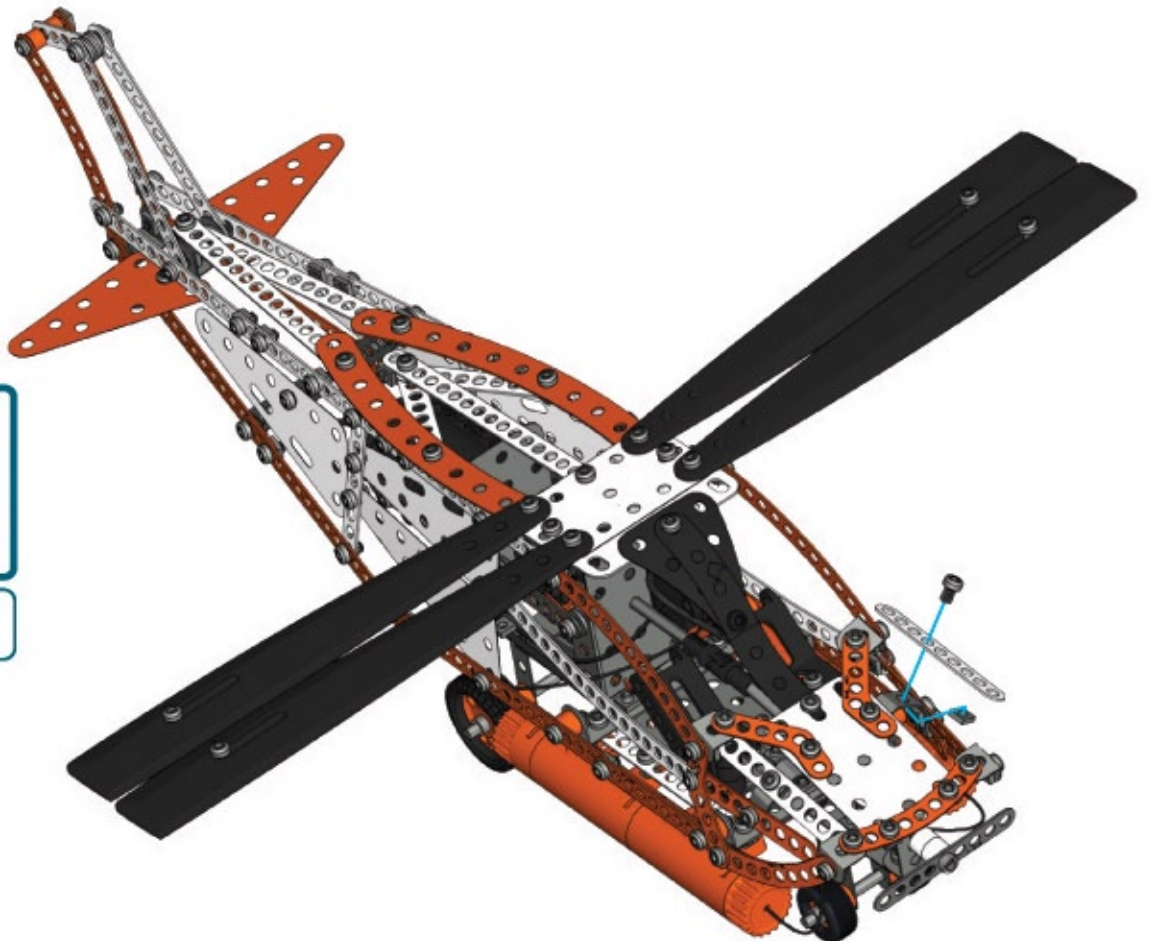

107

	C771 X 1
	A637 (000378) X 1
	A337 (000376) X 1

	S1	1:1
--	-----------	------------

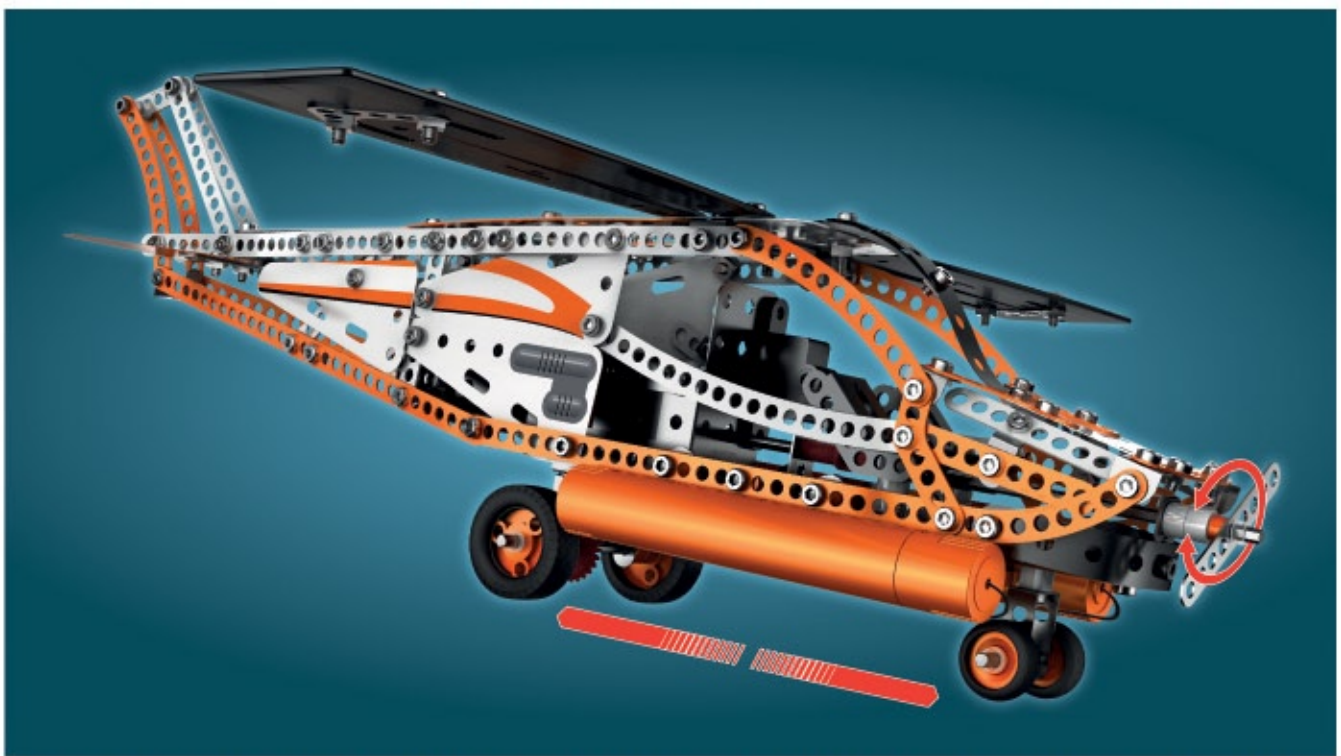
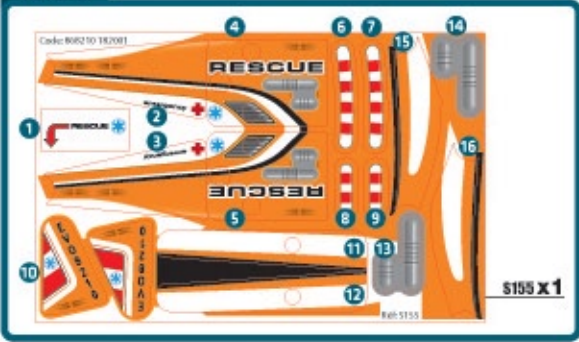

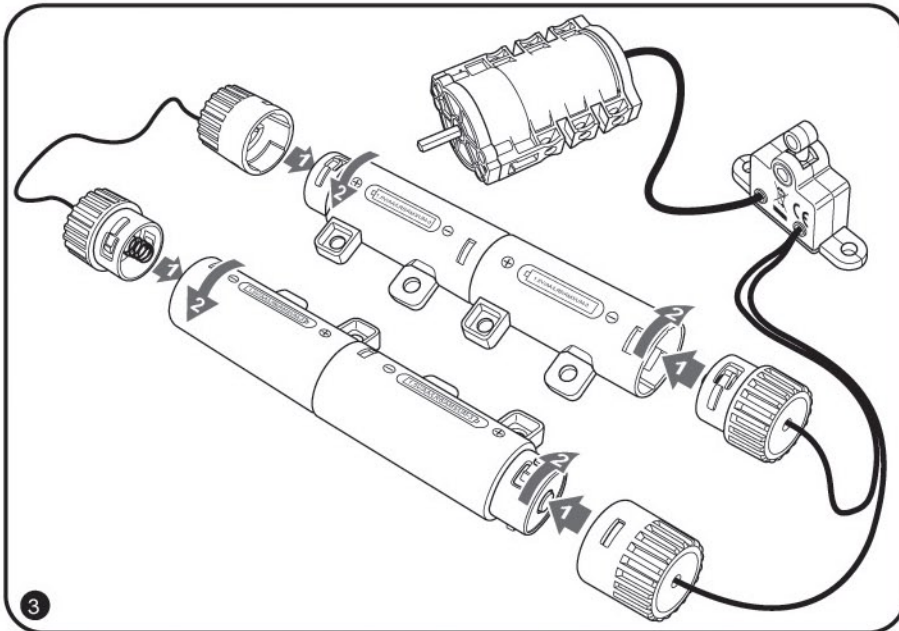
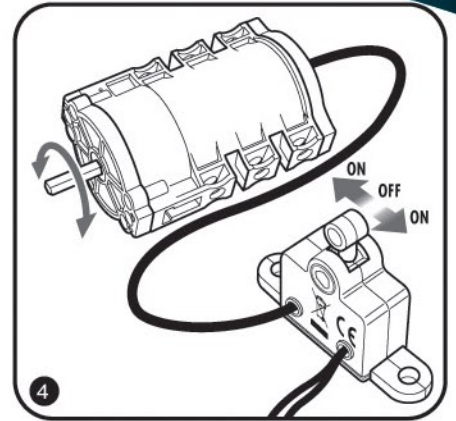
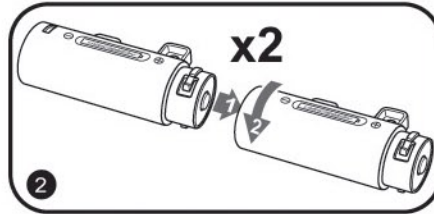
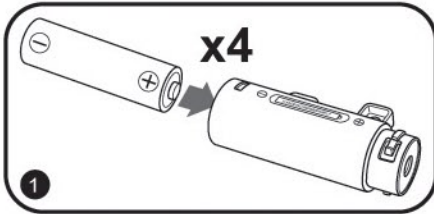

Standard batteries must not be recharged. Rechargeable batteries must be removed from the toy before being recharged (if it is possible to remove them). Rechargeable batteries must only be recharged under adult supervision (if it is possible to remove them). Do not mix different types of batteries together or new with old rechargeable / non rechargeable batteries. Only batteries of the recommended type or a similar type should be used. Batteries must be fitted in accordance with their instructions. Remove used batteries from the toy. Battery terminals must not be short-circuited. Please keep instructions. Do not mix old and new batteries. Do not mix alkaline, standard (carbon-zinc), or rechargeable (nickel-cadmium) batteries.

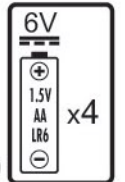

USE 4AA BATTERIES. (not included)

- ⚠ Do not mix old and new batteries. Do not mix alkaline, standard (carbon-zinc), or rechargeable (nickel-cadmium) batteries.
- ⚠ Différents types de piles ou accumulateurs ou des piles ou accumulateurs neufs et usagés ne doivent pas être mélangés.
- ⚠ Unterschiedliche Arten von Batterien und Akkus oder neue und gebrauchte Batterien bzw.
- ⚠ Non possono essere mescolati tipi diversi di pile o accumulatori oppure pile o accumulatori nuovi e usati.
- ⚠ No deberán mezclarse diferentes tipos de pilas o acumuladores o de pilas o acumuladores nuevos y usados.

- ⚠ Diferentes tipos de pilhas ou acumuladores ou pilhas ou acumuladores novos já utilizados não devem ser misturados.
- ⚠ Olika typer av batterier eller ackumulatorbatterier skall inte blandas.
- ⚠ Erityyppisiä paristoja tai akkuja ei saa käyttää yhdessä, samoin ei saa sekoittaa akkuja ja uusia ja vanhoja paristoja.
- ⚠ Forskellige typer batterier og akkumulatorbatterier, eller nye og brugte batterier, må ikke blandes sammen.
- ⚠ Gebruik geen verschillende typen batterijen of accu's of gebruikte en nieuwe batterijen of accu's door elkaar.

- ⚠ Δεν πρέπει να ανακατεύονται διάφοροι τύποι μπαταριών ή συσσωρευτών ή μπαταριών ή συσσωρευτών καινούριων και παλιών. Πρέπει να χρησιμοποιούνται μόνον μπαταρίες ή συσσωρευτές του συνιστάμενου τύπου ή παρόμοιου τύπου.
- ⚠ Не используйте одновременно старые и новые батарейки. Не смешивайте щелочные, стандартные (угольно-цинковые) или перезаряжаемые (никель-кадмиевых) батарейки.

Warning! Attention! Achtung! Attenzione! ¡Atención! Aviso! Varning! Varoitus!
Advarsel! Waarschuwing! Προειδοποίηση! Внимание! Varování! Tähelepanu!
Įspėjimas! Figyelmeztetés! Twissija! Uwaga! Atentje! Pozor! Rabhadh! Uzmanību! внимание!



- GB/USA** Warning! Choking Hazard. Contains small parts which could be swallowed. Not suitable for children under 3 years.
- FR** Attention ! Danger d'étouffement. Contient des petites pièces pouvant être absorbées. Ne convient pas aux enfants de moins de 3 ans.
- D** Achtung! Verschluckungsgefahr. Enthält verschluckbare Kleinteile. Nicht für Kinder unter 3 Jahren geeignet.
- I** Attenzione, pericolo di soffocamento! Contiene pezzi piccoli che potrebbero essere ingoiati. Non adatto ai bambini sotto i 3 anni.
- E** ¡Atención! Riesgo de asfixia. Contiene piezas pequeñas que un niño podría tragarse. No conviene a los niños menores de 3 años.
- P** Aviso! Perigo de se engasgar. Contém peças pequenas que podem ser engolidas. Não aconselhável a crianças com menos de 3 anos.
- S** Varning! Risk för kvävning. Innehåller små delar som kan sväljas. Ej lämplig för barn under 3 års ålder.
- FIN** Varoitus! Tukehtumisvaara. Sisältää pieniä osia, jotka voidaan niellä. Ei soveltu alle 3-vuotiaille lapsille.
- DK** Advarsel! Fare for slugning. Indeholder små dele, som kan sluges. Ikke velegnet for børn under 3 år.
- NL** Waarschuwing ! Verstikkingsgevaar. Bevat kleine onderdelen die kunnen worden ingeslikt. Niet geschikt voor kinderen onder 3 jaar.
- GR** Προειδοποίηση! Κίνδυνος πνιγμού. Περιέχει μικρά εξαρτήματα που θα μπορούσαν να καταποθούν. Ακατάλληλο για παιδιά κάτω από 3 ετών.
- BULGARIAN** Внимание! Опасност от задушаване. Съдържа малки части, които могат да бъдат погълнати. Не е подходящо за деца под 3 години.

- CZECH** Varování ! Nebezpečí udušení. Obsahuje malé díly, které by mohly být spolknuty. Nevhodné pro děti do 3 let.
- ESTONIAN** Tähelepanu ! Lämbumisoht. Sisaldab väikseid osi, mida saab alla neelata. Ei sobi alla 3. aasta vanustele lastele.
- LITHUANIAN** Įspėjimas! Uždusimo pavojus. Yra smulkių dalių, kurias galima nuryti. Netinka vaikams iki 3 metų.
- HUNGARIAN** Figyelmeztetés! Fulladásveszély. Apró alkatrészeket tartalmaz, amelyeket a gyermekek lenyelhetnek. 3 évesnél fiatalabb gyermekek számára nem alkalmas.
- MALTESE** Twissija! Periklu li wiehed jifga. Fih partijiet żgħar li jistgħu jinbelgħu. Mhuxwied adattat għal tfał iżgħar minn 3 snin.
- POLISH** Uwaga! Ryzyko uduszenia. Zawiera małe części, które mogą zostać połknięte. Produkt nieodpowiedni dla dzieci poniżej 3 lat.
- ROMANIAN** Atenție! Pericol de sufocare. Conține piese mici care pot fi înghițite. Interzis copiilor sub 3 ani.
- SLOVAK** Pozor ! Nebezpečenstvo udusenja. Obsahuje malé diely, ktoré je možné prehltnúť. Nie je vhodné pre deti mladšie ako 3 roky.
- SLOVENIAN** Pozor ! Nevarnost zadušitve. Vsebuje majhne dele, ki jih je možno zaužiti. Ni primerno za otroke, mlajše od 3 let.
- IRISH** Rabhadh! Guais Tachta. Piosaí beaga ann a fhéadfhadh a bheith insúite. Níl an bréagán seo oiriúnach do pháistí atá níos óige ná trí bhliain d'aois.
- LATVIAN** Uzmanību! Nosmakšanas draudi. Satur sīkas detaļas, kuras var tikt norītas. Nav piemērots bērniem, kas jaunāki par 3 gadiem. **Внимание! Возможен риск удушья. В наборе имеются мелкие детали, которые легко проглотить. Противопоказан детям младше 3 лет.**



GB/USA

Disposal of electric appliances at the end of their life (applicable in the countries of the European Union and other countries with a system of selective waste collection).

This symbol, placed on the product or its packaging, indicates that this product must not be disposed of with the household waste. It must be handed over at an appropriate collection point for the recycling of electric and electronic appliances. By ensuring that this product is disposed of in an appropriate manner, you will be helping prevent the potentially negative consequences on the environment. The recycling of the materials will help conserve natural resources. For any additional information on the subject of recycling this product, please consult your local authorities, your waste collection centre or the shop where you purchased the product.

When replacing your used batteries, we ask that you observe the regulations in force regarding their disposal. Thank you for depositing them at the place provided to that effect in order to ensure that they are disposed of in a safe manner and the environment is respected.

F

Traitement des appareils électriques et électroniques en fin de vie (applicable dans les pays de l'Union européenne et aux autres pays européens disposant de système de collecte sélective).

Ce symbole, apposé sur le produit ou son emballage, indique que ce produit ne doit pas être traité avec les déchets ménagers. Il doit être remis à un point de collecte approprié pour le recyclage des équipements électriques et électroniques. En s'assurant que ce produit est bien mis au rebut de manière appropriée, vous aiderez à prévenir les conséquences négatives potentielles pour l'environnement et la santé humaine. Le recyclage des matériaux aidera à conserver les ressources naturelles. Pour toute information supplémentaire au sujet du recyclage de ce produit, vous pouvez consulter votre municipalité, votre déchetterie ou le magasin où vous avez acheté le produit.

Lors du remplacement de vos piles usagées, nous vous demandons de suivre la réglementation en vigueur quant à leur élimination. Nous vous remercions de les déposer à un endroit prévu à cet effet afin d'en assurer leur élimination de façon sûre et dans le respect de l'environnement.

D

Verwertung von Elektrogeräten und elektronischen Geräten am Ende ihrer Lebensdauer (gilt in den Ländern der Europäischen Union und in anderen Ländern mit Mülltrennung).

Dieses Symbol auf dem Produkt oder auf der Verpackung bedeutet, dass das Produkt nicht über den Hausmüll entsorgt werden darf. Es muss bei einer geeigneten Sammelstelle für die Wiederverwertung von elektrischen und elektronischen Apparaten abgegeben werden. Indem Sie dafür sorgen, dass das Produkt einer angemessenen Entsorgung zugeführt wird, tragen Sie zur Vermeidung möglicher negativer Auswirkungen auf Umwelt und Gesundheit bei. Die Wiederverwertung von Materialien trägt zur Bewahrung der natürlichen Ressourcen bei. Weiterführende Informationen zur Wiederverwertung dieses Produkts bekommen Sie bei Ihrer Gemeinde- oder Stadtverwaltung, Ihrem Wertstoffhof oder in dem Geschäft, in dem Sie das Produkt gekauft haben.

Wir fordern Sie auf, sich beim Austausch leerer Batterien an die geltenden Vorschriften zu ihrer Entsorgung zu halten. Bringen Sie sie bitte zu einer dafür vorgesehenen Stelle, damit sie sicher und umweltfreundlich entsorgt werden.

I

Trattamento delle apparecchiature elettriche ed elettroniche a fine vita (applicabile nei paesi dell'Unione europea e negli altri paesi europei con sistema di raccolta differenziata).

Questo simbolo, apposto sul prodotto o sul relativo imballo, indica che il prodotto non deve essere smaltito con i rifiuti domestici. Deve essere conferito presso un punto di raccolta appropriato per il riciclaggio delle apparecchiature elettriche ed elettroniche. Assicurandosi che questo prodotto venga smaltito in modo idoneo, l'utente contribuirà a evitare le potenziali conseguenze negative per l'ambiente e la salute umana. Il riciclaggio dei materiali contribuirà alla preservazione delle risorse naturali. Per ulteriori informazioni sul riciclaggio di questo prodotto rivolgersi presso il proprio comune, la discarica pubblica o il negozio in cui è stato effettuato l'acquisto.

Per la sostituzione delle batterie esaurite si richiede di attenersi alle normative in vigore relative allo smaltimento. Conferirle presso un luogo adibito a tale scopo al fine di assicurarne lo smaltimento in sicurezza e nel rispetto dell'ambiente.

E

Tratamiento de los aparatos eléctricos y electrónicos al final de su vida útil (aplicable en los países de la Unión Europea y en los países europeos que cuenten con un sistema de recogida selectiva de residuos).

Este símbolo estampado sobre el producto o su embalaje indica que, cuando finalice su vida útil, el aparato no deberá ser eliminado con los residuos domésticos. Deberá entregarse en el punto de recogida adecuado para el reciclado de los equipos eléctricos y electrónicos. Al hacer lo necesario para garantizar que este producto se deshecha correctamente, ayuda a prevenir las consecuencias negativas para el medio ambiente y la salud humana que podría causar la gestión inadecuada de este tipo de residuos. El reciclado de sus materiales contribuirá a proteger los recursos naturales. Si desea más información sobre el reciclado de este producto, póngase en contacto con su ayuntamiento, el punto de recogida más cercano o la tienda donde adquirió el aparato.

Cuando cambie las pilas usadas, respete la normativa vigente en materia de eliminación de las mismas. Gracias por depositarlas en un lugar previsto a tal efecto para garantizar que se eliminan de forma segura y respetando el medio ambiente.

P

Tratamento dos aparelhos elétricos e eletrônicos em fim de vida (aplicável nos países da União Europeia e nos outros países europeus que disponham de sistema de recolha seletiva).

Este símbolo, afixado no produto ou na respetiva embalagem, indica que este produto não deve ser tratado juntamente com os resíduos domésticos. Deve ser entregue num ponto de recolha apropriado para a reciclagem dos equipamentos elétricos e eletrónicos. Ao garantir que este produto é eliminado de forma apropriada, ajudará a prevenir as potenciais consequências negativas para o ambiente e a saúde humana. A reciclagem dos materiais ajudará a conservar os recursos naturais. Para qualquer informação suplementar a respeito da reciclagem deste produto, pode consultar o seu município, a sua estação de tratamento de resíduos ou a loja onde comprou o produto.

No momento da substituição das suas pilhas usadas, pedimos que siga a regulamentação em vigor quanto à respetiva eliminação. Agradecemos que as coloque num local previsto para o efeito de modo a garantir que a eliminação é feita de forma segura e com respeito pelo ambiente.

S

Behandling av förbrukade elektriska och elektroniska apparater (gäller i EU-länderna och i övriga europeiska länder som tillämpar separat sophämtning).

Den här symbolen som finns på produkten eller dess förpackning anger att denna produkt inte ska slängas med vanligt hushållsavfall. Den ska lämnas in till en lämplig insamlingsstation för återvinning av sina elektriska och elektroniska komponenter. Genom att försäkra dig om att den här produkten kasseras på rätt sätt bidrar du till att förhindra möjliga negativa konsekvenser för miljön och människors hälsa. Återvinning av material bidrar dessutom till att bevara naturresurserna. Om du behöver mer information om hur du ska återvinna den här produkten kan du rådfråga din kommun, din lokala sopstation eller den affär där du köpte produkten.

När du byter ut förbrukade batterier ber vi dig att du följer gällande föreskrifter för hur de ska kasseras. Vi uppskattar att du slänger dem på en för föremålet avsedd plats så att de kasseras på ett säkert och miljövänligt sätt.

FIN

Käytöstä poistettujen sähkö- ja elektronisten laitteiden käsittely (voimassa Euroopan Unionin jäsenvaltioissa ja muissa eurooppalaisissa maissa, jotka käyttävät jätteiden keräysjärjestelmää).

Tuotteeseen tai pakkaukseen merkitty symboli ilmaisee, että tätä tuotetta ei saa käsitellä talousjätteenä. Tuote on sen sijaan luovutettava sopivaan sähkö- ja elektroniikkalaitteiden kierrätyksestä huolehtivaan keräyspisteeseen. Tämän tuotteen asianmukaisen hävittämisen varmistamisella autetaan estämään sen mahdolliset ympäristöön ja terveyteen kohdistuvat haittavaikutukset. Materiaalien kierrätys säästää luonnonvaroja. Tarkempia tietoja tämän tuotteen kierrätyksestä saat paikallisesta kunnantoinmistosta, kierrätyskeskuksesta tai jälleenmyyjältäsi.

Kun poistat tuotteesta käytetyt paristot tai akut, hävitä ne voimassa olevien säännösten mukaisesti. Vie käytetyt paristot ja akut niille tarkoitettuun keräyspisteeseen, jossa ne hävitetään asianmukaisella tavalla ympäristöä säästää.

DK

Behandling af elektriske og elektroniske apparater ved slutningen af deres brugstid (gældende i EU-lande og andre europæiske lande, der råder over et selektivt indsamlingsystem).

Dette symbol, der sidder på produktet eller dets emballage, angiver, at produktet ikke må bortkastes sammen med husholdningsaffaldet. Det skal indleveres på et indsamlingssted beregnet til genbrug af elektrisk og elektronisk udstyr. Når du sørger for, at dette produkt indleveres det rigtige sted ved slutningen af dets levetid, er du medvirkende til at forhindre de negative potentielle virkninger på miljøet og sundheden. Genbrug af materialer er medvirkende til at bevare de naturlige ressourcer. For yderligere oplysninger om genbrug af dette produkt, bedes du tage kontakt til din kommune, genbrugspladsen eller butikken, hvor du har købt produktet.

Ved udskiftning af de brugte batterier, bedes du følge de gældende bestemmelser med hensyn til deres bortskaffelse. Tak, fordi du afleverer dem på et sted beregnet hertil for at sikre, at de bliver tilintetgjort på en sikker og miljøvenlig måde.

NL

Behandeling van elektrische en elektronische apparaten op het einde van hun levensduur (van toepassing in de E.U. en in de andere Europese landen die een systeem voor selectieve inzameling hanteren).

Dit symbool, dat op het product of op de verpakking staat, toont aan dat het product niet als huishoudafval mag worden behandeld. Breng het product naar het geschikte inzamelpunt voor recyclage van elektrische en elektronische toestellen. Door ervoor te zorgen dat dit product op de geschikte manier wordt verwijderd, helpt u de mogelijke schadelijke gevolgen voor milieu en mens te voorkomen. Recyclage van materiaal draagt bij tot het behoud van de natuurlijke hulpbronnen. Voor extra informatie over de recyclage van dit product kunt u terecht bij uw gemeente, uw milieupark of de winkel waar u het product heeft gekocht.

Wat het vervangen van de batterijen betreft, vragen we u de geldende regelgeving te volgen die van kracht is op het ogenblik dat u ze verwijderd. We bedanken u ulvast om deze op de daartoe voorziene plaats te deponeren zodat deze zeker op een veilige en milieuvriendelijke manier worden verwijderd.

GR

Επεξεργασία των ηλεκτρικών και ηλεκτρονικών συσκευών στο τέλος κύκλου ζωής τους (εφαρμοστέο στις χώρες της Ευρωπαϊκής Ένωσης και στις άλλες ευρωπαϊκές χώρες που διαθέτουν σύστημα επιλεκτικής συλλογής).

Το σύμβολο αυτό, αναγραφόμενο επάνω στο προϊόν ή στη συσκευασία του, σημαίνει ότι το προϊόν αυτό δεν πρέπει να απομακρυνθεί μαζί με τα οικιακά απόβλητα. Πρέπει να παραδοθεί σε ένα κατάλληλο σημείο συλλογής για την ανακύκλωση των ηλεκτρικών και ηλεκτρονικών συσκευών. Διασφαλίζοντας ότι το προϊόν αυτό θα απομακρυνθεί κατάλληλα, βοηθάτε στην πρόληψη των ενδεχόμενων αρνητικών επιπτώσεων για το περιβάλλον και την ανθρώπινη υγεία. Η ανακύκλωση των υλικών θα βοηθήσει στη διατήρηση των φυσικών πόρων. Για κάθε πρόσθετη πληροφορία σχετικά με την ανακύκλωση του προϊόντος αυτού, μπορείτε να επικοινωνήσετε με το Δήμο σας, την εταιρεία αποκομιδής σκουπιδιών ή το κατάστημα όπου αγοράσατε το προϊόν.

Όταν αντικαθιστάτε τις μπαταρίες, παρακαλείσθε να τηρείτε την ισχύουσα νομοθεσία σχετικά με την απομάκρυνσή τους. Σας ευχαριστούμε που τις εναποθέτετε στα προβλεπόμενα σημεία συλλογής ούτως ώστε να απομακρυνθούν με ασφάλεια και με σεβασμό για το περιβάλλον.

BULGARIAN

Третирание на излезлите от употреба електрически и електронни уреди (приложимо за всички страни от Европейския съюз и за останалите европейски страни, които разполагат със система за разделно събиране на отпадъците).

Този поставен върху продукта или опаковката му символ показва, че този продукт не трябва да бъде третиран заедно с битовите отпадъци. Той трябва да бъде оставен в подходящ събирателен пункт за рециклиране на електрическо и електронно оборудване. Като осигурите правилното изхвърляне на този продукт, вие ще спомогнете за предотвратяването на възможните вредни въздействия върху околната среда и човешкото здраве. Рециклирането на материалите ще спомогне за опазването на природните ресурси. За повече информация относно рециклирането на този продукт можете да се обърнете към Вашата община, Вашия предавателен пункт или магазина, в който сте купили продукта. При смана на употребените батерии Ви молим да спазвате действащото законодателство по отношение на тяхното изхвърляне. Ако обичате, изхвърлете ги на предвидено за тази цел място, за да може те да бъдат обезвредени по сигурен и щадящ околната среда начин.

CZECH

Likvidace elektrických spotřebičů na konci jejich životnosti (platí v zemích Evropské unie a dalších zemích se systémem sběru tříděného odpadu).

Tento symbol umístěný na výrobku nebo na jeho obalu indikuje, že výrobek nesmí být likvidován s domovním odpadem. Musí být předán na příslušné sběrné místo pro recyklaci elektrických a elektronických přístrojů. Zajištěním správné likvidace tohoto výrobku pomůžete předcházet potenciálním negativním dopadům na životní prostředí. Recyklace materiálů přispívá k uchování přírodních zdrojů. Další informace o likvidaci starého vybavení si laskavě vyžádejte od místních úřadů, podniku zabývajícího se likvidací komunálních odpadů nebo obchodu, kde jste výrobek zakoupili.

Při výměně použitých baterií vás prosíme, abyste respektovali platné předpisy týkající se jejich likvidace. Děkujeme vám za to, že je odložíte na místě k tomu určeném, abyste tak zajistili jejich bezpečnou likvidaci šetrnou k životnímu prostředí.

ESTONIAN

Elektri- ja elektroonikaseadmete jäätmete käitlemine (rakendatav Euroopa Liidu liikmesriikides ja teistes Euroopa riikides, kus on olemas sorteeritud jäätmete kogumissüsteem).

See sümbol tootel või pakendil näitab, et toodet ei tohi käidelda koos olmejäätmetega. See tuleb toimetada elektri- ja elektroonikaseadmete kogumispunkti. Hoollitsedes käesoleva toote nõuetekohase hävitamise eest, aitate ühtlasi ära hoida võimalikke negatiivseid tagajärgi keskkonnale ja inimeste tervisele. Materjalide taaskasutus aitab säästa loodusressursse. Täiendavat teavet käesoleva toote jäätmekäitluse kohta küsige kohalikust omavalitsusest, jäätmekäitlusega tegelevast ettevõttest või kauplusest, kust toote ostsite.

Patareide väljavahetamisel palume teil järgida kasutatud patareide kõrvaldamise kohalikke eeskirju. Täname nende viimise eest selleks ettenähtud kogumiskohta, et tagada nende ohutu ja keskkonda austav kõrvaldamine.

LITHUANIAN

Elektros prietaisų išmetimas pasibaigus jų naudojimui laikui (taikytina Europos Sąjungos ir kitoms šalims, kuriose naudojama atliekų rūšiavimo sistema).

Šis ženklas ant gaminio arba jo pakuotės reiškia, kad šio gaminio negalima išmesti kartu su buitiniemis atliekomis. Jį reikia atiduoti į atitinkamą atliekų surinkimo punktą, skirtą elektros ir elektronikos prietaisams surinkti ir perdirbti. Užtikrindami, kad šis gaminys būtų tinkamai išmestas, jūs padėsite saugoti aplinką nuo galimai neigiamų padarinių. Pakartotinis medžiagų panaudojimas padės tausoti gamtos išteklius. Papildomos informacijos apie šio gaminio perdirbimą gali suteikti vietos valdžios institucijos, buitinių atliekų surinkimo tarnyba arba parduotuvė, kurioje įsigijote šį gaminį.

Keičiant panaudotus maitinimo elementus, būtina laikytis galiojančių vietos taisyklių dėl jų išmetimo. Ačiū, kad išmetate juos tam skirtose vietose, siekdami užtikrinti, jog jie būtų surenkami saugiai, tausojant aplinką.

HUNGARIAN

Az elektromos készülékek hulladékra helyezése élettartamuk lejártá után (Az EU országain belül és más - a szelektív hulladékgyűjtés rendszerét alkalmazó - országokon belül alkalmazandó).

Ez a szimbólum a terméken vagy annak csomagolásán azt jelzi, hogy a termék tilos a háztartási hulladékkal együtt helyezni hulladékra. A terméket át kell adni a megfelelő gyűjtőhelyen az elektromos és elektronikus berendezések újrahasznosításá céljából. A megfelelő elhelyezés biztosításával segít megelőzni az esetleges negatív környezeti ártalmak kialakulását. Az anyagok újrahasznosítása segít megővni a természeti erőforrásokat. Bármilyen további információért a termék újrahasznosítására vonatkozóan, kérjük, forduljon a helyi hatóságokhoz, a hulladékgyűjtési központhoz vagy az üzlethez, ahol a terméket vásárolta.

A használt elemek kicserélésekor, arra kérjük, hogy tartsa be a hatályos vonatkozó rendelkezéseket. Köszönjük, hogy a kijelölt pontban helyezte azokat hulladékra, elősegítve, hogy azok ártalmatlanítása biztonságos módon és a környezet tisztéletben tartásával történjen.

MALTESE

Ir-rimi ta' apparat tal-elettriku li jkun wasal fit-tmiem tal-hajja tiegħu (applikabbli fil-pajjizi tal-Unjoni Ewropea u f'pajjizi oħrajn b'sistema ta' ġbir ta' skart selettiv).

Dan is-simbolu, impoġġi fuq il-prodott jew fuq l-imballaġġ tiegħu, jindika li dan il-prodott ma għandux jintrema mal-iskart domestiku. Għandu jiġi pprezentat f'punt ta' ġbir adegwat għar-riċiklaġġ ta' apparat tal-elettriku u elettroniku. Billi jiġi żgurat li dan il-prodott jintrema bil-mod ix-xieraq, inti tkun qed tgħin fil-prevenzjoni ta' konsegwenzi potenzjalment negattivi fuq l-ambjent. Ir-riċiklaġġ tal-materjali sejjer jgħin fil-konservazzjoni tar-riżorsi naturali. Għal kwalunkwe informazzjoni addizzjonali dwar is-suġġett tar-riċiklaġġ ta' dan il-prodott, jekk jogħġbok ikkonsulta lill-awtoritajiet lokali tiegħek, liċ-centru ta' ġbir ta' skart jew lill-hanut minn fejn xtrajt il-prodott.

Meta tissostitwixxi l-batteriji użati tiegħek, aħna nitolbuk li tosserva r-regolamenti fis-seħh dwar ir-rimi tagħhom. Grazie talli tarnihom fil-post ipprovdut għal dan il-ghan sabiex jintremew b'mod sikur u l-ambjent jiġi rispettatt.

POLISH

Pozbycie się zużytego sprzętu elektrycznego i elektronicznego (stosowane w krajach Unii Europejskiej i innych krajach europejskich posiadających systemy zbiorczy selektywnej).

Symbol ten, umieszczony na produkcie lub jego opakowaniu, wskazuje, że produkt ten nie powinien być usuwany wraz z odpadami komunalnymi, lecz złożony w odpowiednim punkcie zbiórki zużytego sprzętu elektrycznego i elektronicznego. Upewniając się, że produkt ten jest prawidłowo usunięty, zapobiegasz potencjalnym negatywnym skutkom dla środowiska naturalnego i zdrowia ludzkiego. Recykling materiałów pomaga zachować zasoby naturalne. Aby uzyskać szczegółowe informacje dotyczące recyklingu tego produktu, należy skontaktować się z urzędem miasta lub gminy, punktem zbiórki lub sklepem, w którym dokonano zakupu produktu.

Podczas wymiany zużytych baterii prosimy zastosować się do obowiązujących przepisów dotyczących ich usuwania. Prosimy o złożenie ich w przeznaczonym do tego celu miejscu, aby zapewnić ich bezpieczne usunięcie, niezagrażające środowisku naturalnemu.

ROMANIAN

Evacuarea echipamentelor electrice la finalul duratei de utilizare (aplicabilă în țările Uniunii Europene și în alte țări care dispun de un sistem de colectare selectivă a deșeurilor).

Acest simbol, aplicat pe produs sau pe ambalajul acestuia, indică faptul că acest produs nu trebuie eliminat împreună cu deșeurile menajere. Acesta trebuie predat unui centru corespunzător de colectare în vederea reciclării echipamentelor electrice și electronice. Asigurându-vă că acest produs este eliminat în mod adecvat, veți contribui la prevenirea posibilelor consecințe negative asupra mediului înconjurător. Prin reciclarea materialelor, veți ajuta la conservarea resurselor naturale. Pentru orice informații suplimentare cu privire la reciclarea acestui produs, vă rugăm să consultați centrul local de reciclare sau magazinul de unde ați achiziționat produsul. Când înlocuiți bateriile uzate, vă rugăm să respectați regulamentele în vigoare, referitoare la eliminarea acestora. Vă mulțumim că le predați unui centru special pentru a vă asigura că sunt eliminate în siguranță și respectând mediul înconjurător.

SLOVAK

Spracovanie elektrických a elektronických zariadení na konci životnosti (platné v krajinách Európskej únie a európskych krajinách, ktoré disponujú systémom selektívneho zberu).

Tento symbol na výrobku alebo jeho obale informuje, že tento produkt nesmie byť spracovaný s odpadom z domácností. Je potrebné ho odovzdať na zbernom mieste určenom pre recykláciu elektrických a elektronických zariadení. Tým, že tento výrobok odstránite náležitým spôsobom, dopomôžete tak zabráneniu možných negatívnych vplyvov na životné prostredie a zdravie ľudí. Recyklácia materiálov napomáha zachovávaníu prírodných zdrojov. V prípade akékoľvek otázky týkajúcej sa recyklácie tohto výrobku môžete kontaktovať svoj mestský úrad, spoločnosť, ktorá zabezpečuje odvoz odpadu alebo predajňu, v ktorej ste tento výrobok kúpili.

Pri výmene opotrebovaných batérií vás žiadame o dodržanie platných zákonných nariadení týkajúcich sa ich odstraňovania. Odovzdajte ich prosím na mieste, ktoré je určené pre tento účel, čím zabezpečíte ich bezpečné a pre životné prostredie neškodné odstránenie.

SLOVENIAN

Odstranjevanje električne in elektronske opreme ob koncu njene življenjske dobe (velja v državah Evropske unije in drugih evropskih državah, kjer je v veljavi ločeno zbiranje odpadkov).

Ta simbol na izdelku ali njegovi embalaži označuje, da se izdelka ne sme odložiti med gospodinjске odpadke. Odložiti ga je treba na zbirno mesto za recikliranje električne in elektronske opreme. Če izdelek ustrezno zavržete, s tem pomagata preprečevati morebitne negativne posledice za okolje in zdravje ljudi. Recikliranje materialov pripomore k ohranjanju naravnih virov. Nadaljnje informacije v zvezi z recikliranjem tega izdelka so na voljo v vaši občini, na deponiji odpadkov ali v trgovini, kjer ste izdelek kupili.

Pri menjavi baterij upoštevajte veljavne predpise o njihovem odlaganju. Zahvaljujemo se vam za uporabo predvidenih zbiralnikov za odpadne baterije, saj tako zagotovite uničenje baterij na varen način, ki spoštuje okolje.

IRISH

Diúscairt fearas leictreacha ag deireadh a saoil (infheidhmhithe i dtíortha an Aontais Eorpaigh agus i dtíortha eile ina bhfuil córas de bhailiú roghnach dramhaíola).

Tugann an siombal seo, a chuirtear ar an táirge ná ar an bpacáistiú ag gabháil leis, le fios nach ceart an táirge seo a dhiúscairt le dramhaíl an teaghlaigh. Ní mór é a thabhairt suas ag ionad cuí bailithe ina ndéantar fearais leictreacha is leictreonacha a athchúrsáil. Trí chinntiú go ndéantar an táirge seo a dhiúscairt ar mhodh cuí, beidh tú ag cabhrú chun iarmhairtí diúltacha ar an timpeallacht a sheachaint. Cabhróidh athchúrsáil an ábhair chun acmhainní nádúrtha a chaomhnú. Chun aon eolas breise a fháil faoi athchúrsáil an táirge seo, déan teagmháil más é do thoil é le d'údarás áitiúil, d'ionad bailithe dramhaíola nó leis an siopa inar cheannaigh tú an táirge.

Agus na codhnaí caithe á gcaitheamh uait, iarrann muid ort cloí leis na rialacháin atá i bhfeidhm faoina ndiúscairt. Go raibh maith agat as iad a dhiúscairt ag an áit a cuireadh ar fáil le haghaidh sin chun a chinntiú go ndéantar iad a dhiúscairt ar mhodh sábháilte agus go dtugtar urraim don timpeallacht.

LATVIAN

Atbrīvošanās no elektriskām ierīcēm, kuras vairs netiek izmantotas (attiecas uz Eiropas Savienības valstīm un citām valstīm, kurās pastāv selektīva atkritumu savākšanas sistēma).

Šis simbols, kas atrodas uz ražojuma vai tā iepakojuma, norāda, ka šo ražojumu nedrīkst izmest kopā ar sadzīves atkritumiem. Tas jānodod īpašā pārstrādāšanai paredzēto elektrisko un elektronisko ierīču savākšanas punktā. Nodrošinot, ka šis ražojums tiek iznīcināts atbilstīgā veidā, jūs palīdzēsiet novērst iespējamo negatīvo ietekmi uz vidi. Materiālu pārstrāde palīdz saglabāt dabas resursus. Lai iegūtu papildu informāciju par šī ražojuma pārstrādi, lūdz, sazinieties ar vietējām varas iestādēm, tuvāko atkritumu savākšanas centru vai veikal, kurā jūs iegādājāties šo ražojumu.

Nomainot izlietotās baterijas, lūdz, ievērojiet spēkā esošos noteikumus par to iznīcināšanu. Lūdz, novietojiet tās šim nolūkam paredzētajā vietā, lai nodrošinātu to, ka to iznīcināšana notiek droši un ka tiek ievēroti ar vides aizsardzību saistītie apsvērumi.

GB USA Many of the models and component parts are unique and original designs which are the property of MECCANO. They are protected by national legislation as industrial designs, trademarks and/or copyrights throughout many countries. For detailed information, please contact: MECCANO. Meccano shall have no responsibility for (I) failure to follow instructions, (II) use of parts for any purpose other than as specified in the instructions (III) any alteration of any parts or components. MECCANO respects children's safety: all models are tested by children.

F De nombreux modèles et pièces sont des créations originales, propriétés de MECCANO et sont protégés par les législations nationales sur les dessins et modèles, marques et/ou droits d'auteurs. Pour toute information, merci de contacter : MECCANO. La responsabilité de MECCANO ne saurait être engagée en cas d'accident survenu à la suite (I) du non respect des instructions de montage (II) d'une utilisation des pièces autre que celle proposée dans la notice (III) d'une altération ou de la modification des pièces. La société MECCANO respecte la sécurité des enfants : ses modèles sont testés par des enfants.

D Zahlreiche Modelle und Teile sind Erfindungen und Eigentum der Firma MECCANO. Sie sind durch Inland-Gesetze über Zeichnungen und Modelle sowie Warenzeichen und/oder Urheberrechte geschützt. Für zusätzliche Auskünfte wenden Sie sich bitte an : MECCANO. Die Firma Meccano haftet nicht für Unfälle, die aus der (I) Nichteinhaltung der Bauanleitung, der (II) Verwendung anderer als in der Bauanleitung angegebenen Teile oder der (III) Änderung oder Modifikation der Teile resultieren. Alle Modelle der Firma Meccano wurden von Kindern getestet und entsprechen den Sicherheitsnormen.

I Numerosi modelli e pezzi sono creazioni originali della MECCANO e sono protetti dalle legislazioni nazionali sui disegni e modelli, marche e/o diritti d'autore. Per qualsiasi informazione, vogliate prendere contatto con : MECCANO. Meccano declina ogni responsabilità in caso d'incidenti sopravvenuti in seguito (I) a non rispetto delle istruzioni di montaggio (II) utilizzo dei pezzi per funzioni diverse da quelle previste nel manuale (III) alterazione e/o modifica dei pezzi. La società MECCANO rispetta la sicurezza dei bambini : i suoi modelli vengono testati dai bambini stessi.

E Numerosos modelos y piezas son creaciones originales, propiedades de MECCANO y están protegidos por las legislaciones nacionales en lo que concierne a los dibujos y modelos, marcas y/o derechos de autor. Para cualquier información, sírvase ponerse en contacto con : MECCANO. MECCANO carece de responsabilidad en caso de accidente debido a: (I) el incumplimiento de las instrucciones de montaje (II) pelo uso indebido de las piezas o (III) la modificación de las instrucciones (III) una alteración o modificación de las piezas. La sociedad MECCANO respeta la seguridad de los niños : sus modelos están probados por niños.

P Vários modelos e peças são criações originais, propriedades da MECCANO e são protegidos pelas legislações nacionais relativas aos desenhos e modelos às marcas e/ou aos direitos de autor. Para qualquer informação, é favor contactar : MECCANO. A Sociedade MECCANO não poderá ser responsabilizada pelos acidentes provocados: (I) pela falta de cumprimento das instruções de montagem (II) pelo uso indevido das peças ou (III) pela modificação ou alteração das peças. A Sociedade MECCANO respeita a segurança das crianças : os seus modelos foram testados por crianças.

GB USA Standard batteries must not be recharged. Rechargeable batteries must be removed from the toy before being recharged (if it is possible to remove them). Rechargeable batteries must only be recharged under adult supervision (if it is possible to remove them). Do not mix different types of batteries together or new with old rechargeable / non rechargeable batteries. Only batteries of the recommended type or a similar type should be used. Batteries must be fitted in accordance with their instructions. Remove used batteries from the toy. Battery terminals must not be short-circuited. Please keep instructions.

F Les piles ne doivent pas être rechargées. Les accumulateurs doivent être enlevés du jouet avant d'être chargés (s'ils peuvent être enlevés). Les accumulateurs ne doivent être chargés que sous la surveillance d'un adulte (s'ils peuvent être enlevés). Différents types de piles ou accumulateurs ou des piles ou accumulateurs neufs et usagés ne doivent pas être mélangés. Seuls des piles ou accumulateurs du type recommandé ou d'un type similaire doivent être utilisés. Les piles et accumulateurs doivent être mis en place en respectant la polarité. Les piles et accumulateurs usagés doivent être enlevés du jouet. Les bornes d'une pile ou d'un accumulateur ne doivent pas être mises en court-circuit. Indications à conserver.

D Die Batterien dürfen nicht wieder aufgeladen werden. Die Akkus müssen vor dem Nachladen aus dem Spielzeug genommen werden (wenn sie ausgebaut werden können). Die Akkus dürfen nur unter Aufsicht eines Erwachsenen nachgeladen werden (wenn sie ausgebaut werden können). Unterschiedliche Arten von Batterien und Akkus oder neue und gebrauchte Batterien bzw. Akkus dürfen nicht zusammen verwendet werden. Es dürfen nur Batterien bzw. Akkus der empfohlenen Art oder einer ähnlichen Art verwendet werden. Beim Einsetzen der Batterien bzw. Akkus auf die richtige Polung achten. Verbrauchte Batterien bzw. Akkus bitte aus dem Spielzeug entfernen. Die Klemmen der Batterien bzw. Akkus dürfen nicht kurzgeschlossen werden. Diese Anweisungen bitte aufbewahren.

I Le pile non devono essere ricaricate. Gli accumulatori devono essere tolti dal giocattolo prima di essere caricati (se è possibile toglierli). Gli accumulatori devono essere caricati solo sotto la sorveglianza di un adulto (se è possibile toglierli). Non possono essere mescolati tipi diversi di pile o di accumulatori oppure pile o accumulatori nuovi e usati. Si devono usare solo pile o accumulatori del tipo raccomandato o di un tipo simile. Le pile e gli accumulatori devono venire sistemati rispettando la polarità. Le pile e gli accumulatori usati devono essere tolti dal giocattolo. I morsetti di una pila o di un accumulatore non devono essere messi in cortocircuito. Conservare queste istruzioni.

E Las pilas no deberán recargarse. Habrá que retirar los acumuladores del juguete antes de proceder a recargarlos (si es que pueden retirarse). Los acumuladores sólo se recargarán bajo la vigilancia de una persona adulta (si es que pueden retirarse). No deberán mezclarse diferentes tipos de pilas o acumuladores o de pilas o acumuladores nuevos y usados. Sólo se utilizarán pilas o acumuladores del tipo recomendado o de un tipo similar. Las pilas y acumuladores deberán colocarse respetando la polaridad. Deberán retirarse del juguete las pilas y acumuladores usados. Los bornes de una pila o de un acumulador no deberán disponerse nunca en posición de cortocircuito. Conserve estas indicaciones.

P As pilhas não devem ser novamente carregadas. Os acumuladores devem ser removidos do brinquedo antes de serem carregados (caso possam ser removidos). Os acumuladores devem ser carregados apenas sob cuidados de um adulto (caso possam ser removidos). Diferentes tipos de pilhas ou acumuladores ou pilhas ou acumuladores novos já utilizados não devem ser misturados. Pilhas ou acumuladores do tipo recomendado ou de um tipo similar poderão ser utilizados. As pilhas e acumuladores devem ser inseridos, respeitando a polaridade. Devem ser removidos do brinquedo as pilhas e acumuladores já utilizados. Os pólos de uma pilha ou de um acumulador não devem ser curto-circuitados. Indicações a conservar.

S Många modeller och delar bildar en unik och originell formgivning vilken är MECCANO egendom. Dessa modeller och delar är skyddade genom lagstiftning såsom industriell formgivning, varumärke och/eller upphovsmanrätt i ett flertal länder. För mer detaljerad information, var vänlig och kontakta MECCANO. MECCANO främjar sig allt ansvar i händelse av olycka till följd av (I) att monteringsinstruktionerna inte har respekterats (II) en annan användning av delarna än den som står i anvisningen (III) en förvanskning eller förändring av delarna. Företaget MECCANO respekterar barnsäkerheten : modellerna har testats av barn.

FIN Useat mallit ja osat ovat MECCANO:n omaisuutta olevaa alkupeleistä suunnittelua. Ne ovat kansallisilla lailla suojattua teollista tuotantoa, tavaramerkkejä ja/tai kopiointioikeuksia. Pyydämme ottamaan yhteyden MECCANO:han kaikissa asioissa liittyvissä kysymyksissä. MECCANO ei vastaa eikä kata seuraavista syistä sattuneita onnettomuuksia: (I) ohjeiden vastainen kokoaminen, (II) muiden kuin ohjeissa ehdotettujen osien käyttö, (III) osien muuttelu tai eri tarkoitukseen käyttö. MECCANO-yhtiö huolehtii lasten turvallisuudesta: lapset ovat testanneet mallimme.

DK Vore mange modeller og dele er originale fremstillinger og ejes af MECCANO. Tegninger, modeller, fabrikmærker og oplysninger er lovbeskyttede i hvert land. Yderligere oplysninger kan fås hos: MECCANO. MECCANO frsiger sig ethvert ansvar, sftremt der er sket uheld forrsaget af (I) at monteringsinstruktionerne ikke er blevet overholdt, (II) at delene er blevet brugt til andre formål, end dem der er beskrevet i betjeningsvejledningen, (III) eller at delene er blevet beskadiget eller ændret. MECCANO overholder sikkerhedsreglerne for børn: Alle modeller testes af børn.

NL Veel modellen en onderdelen zijn originele ontwerpen en eigendom van MECCANO en worden beschermd door de nationale wetgeving op tekeningen en modellen, merken en/of auteursrechten. Voor informatie gelieve contact op te nemen met MECCANO. De verantwoordelijkheid van MECCANO is uitgesloten in geval van ongevalen voortvloeiend uit het niet naleven van de montage-instructies (I), uit het gebruik van andere onderdelen dan die zoals vermeld in de handleiding (II) of uit het veranderen of modificeren van de onderdelen (III). De firma MECCANO neemt de veiligheid van de kinderen in acht : de modellen zijn door kinderen getest.

GR Πολλά μοντέλα και ανταλλακτικά είναι αυθεντικά, ιδιοκτησία της MECCANO και προστατεύονται από τις εθνικές νομοθεσίες για τα μοντέλα τις μάρκες ή τα διπλώματα ευρεσιτεχνίας. Για κάθε πληροφορία Για κάθε πληροφορία παρακαλώ απευθυνθείτε στη MECCANO. Η ευθύνη της MECCANO δεν δεσμεύεται σε περίπτωση ατυχημάτων που είναι συνεχής (I) μη σεβασμού των οδηγιών συναρμολόγησης (II) χρήσης των τεμαχίων διαφορετικά από αυτήν που προτείνεται στις οδηγίες (III) καταστροφή ή αλλαγή των τεμαχίων. Η εταιρεία MECCANO σεβεται την ασφάλεια των παιδιών: τα μοντέλα της δοκιμάζονται από παιδιά.

RUS Многие модели и детали набора являются уникальными. Их оригинальная концепция является собственностью компании MECCANO. Модели защищены законодательством различных стран в качестве торговой марки промышленного дизайна или на основании закона об авторских правах. Для получения более подробной информации, пожалуйста, свяжитесь с представителем MECCANO. Meccano не несет ответственности в случае: I) несоблюдения инструкций, II) использования деталей конструктора не по назначению, III) любой деформации деталей конструктора. MECCANO заботится о детской безопасности: все модели тестируются детьми.

S Batterierna skall inte laddas om. Ackumulatorbatterierna skall tas av från leksaken innan de laddas (om de kan tas av). Ackumulatorbatterierna skall endast laddas under uppsikt av en vuxen (om de kan tas av). Olika typer av batterier eller ackumulatorbatterier skall inte blandas. Nya och använda batterier eller ackumulatorbatterier skall inte blandas. Använd endast rekommenderade typer eller likartade typer av batterier eller ackumulatorbatterier. Batterierna och ackumulatorbatterierna skall sättas i med hänsyn till polaritet. Använda batterier och ackumulatorbatterier skall tas av från leksaken. Kontakterna på ett batteri eller ett ackumulatorbatteri skall inte kortslutas. Bevara anvisningarna.

FIN Paristoja ei saa ladata uudelleen. Akut on otettava ulos leikkikalusta ennen lataamista (jos se on mahdollista). Akut saa ladata vain aikuisen valvonnassa (jos ne voidaan ottaa ulos). Erityyppisiä paristoja tai akkuja ei saa käyttää yhdessä, samoin ei saa sekoittaa akkuja ja usia ja vanhoja paristoja. Vain suositelluja akku- tai paristotyyppijä saa käyttää tai tyyppijä, joilla on samat ominaisuudet. Paristo ja akut on asetettava paikoilleen niin, että navat tulevat oikeisiin suuntiin. Loppunäkätetyt paristot tai akut on otettava leikkikalusta ulos. Akun tai pariston napoja ei saa aikosulkea. Ohjeet on pidettävä tallessa.

DK Batterierne må ikke oplades. Akkumulatorbatterier skal tages ud af legetøjet, inden de lades op (hvis de kan tages ud). Akkumulatorbatterierne må kun lades op under opsyn af voksne (hvis de kan tages ud). Forskellige typer batterier og akkumulatorbatterier, eller nye og brugte batterier, må ikke blandes sammen. Der må kun anvendes batterier eller akkumulatorbatterier af den type der er anbefalet eller tilsvarende modeller. Batterier og akkumulatorbatterier skal vendes rigtigt (+/- polar). Brugte batterier og akkumulatorbatterier skal tages ud af legetøjet. Klemmerne på et batteri eller et akkumulatorbatteri må ikke kortsluttes. Disse instruktioner bør opbevares.

NL De batterijen mogen niet weer opgeladen worden. De accu's moeten voor het laden uit het speelgoed verwijderd worden (indien ze verwijderd kunnen worden). Gebruik geen verschillende typen batterijen of accu's of gebruikte en nieuwe batterijen of accu's door elkaar. Gebruik alleen batterijen of accu's van het aanbevolen type of van een gelijkwaardig type. Lat bij het plaatsen van de batterijen en accu's goed op de juiste polariteit. De gebruikte batterijen en accu's dienen uit het speelgoed verwijderd te worden. De aansluitingen van een batterij of van een accu mogen niet kortgesloten worden. Aanwijzingen om te bewaren.

GR Οι μπαταρίες δεν πρέπει να επαναφορτίζονται. Οι συσσωρευτές πρέπει να αφαιρούνται από το παιχνίδι πριν τη φόρτιση (εάν μπορούν να αφαιρεθούν). Οι συσσωρευτές πρέπει να φορτίζονται μόνον υπό την επίβλεψη ενήλικα (εάν μπορούν να αφαιρεθούν). Δεν πρέπει να ανακατεύονται διάφοροι τύποι μπαταριών ή συσσωρευτών ή μπαταριών ή συσσωρευτών και παλιών. Πρέπει να χρησιμοποιούνται μόνον μπαταρίες ή συσσωρευτές του συνιστάμενου τύπου ή παρόμοιου τύπου. Οι μπαταρίες και οι συσσωρευτές πρέπει να τοποθετούνται σύμφωνα με τη σωστή πόλωση. Οι παλιές μπαταρίες και οι παλιοί συσσωρευτές πρέπει να αφαιρούνται από το παιχνίδι. Οι πόλοι μιας μπαταρίας ή ενός συσσωρευτή δεν πρέπει να βραχυκυκλώνονται. Διατηρήστε τις οδηγίες.

USA Do not mix old and new batteries. Do not mix alkaline, standard (carbon-zinc), or rechargeable (nickel-cadmium) batteries.

RUS Не используйте одновременно старые и новые батарейки. Не смешивайте щелочные, стандартные (угольно-цинковые) или перезаряжаемые никель-кадмиевые батарейки.



363, avenue de Saint Exupéry, 62100 Calais - France

<http://www.meccano.com> <http://www.erektor.us>

© 07/2013 MECCANO

®MECCANO and ERECTOR are exclusive trademarks of MECCANO
All Rights Reserved.

