

GEARS OF WAR JUDGMENT™



- Ⓔ Merci d'imprimer échelle 1 sans les marges de l'imprimante.
- Ⓕ Please print scale 1 without the printer margins.
- Ⓖ Den Maßstab 1 bitte randlos drucken.
- Ⓒ Stampare la scala 1 senza i margini della stampante.
- Ⓒ Imprimir a escala 1 sin los márgenes de la impresora.
- Ⓔ Favor imprimir escala 1 sem as margens da impressora.
- Ⓢ Skriv ut i skala 1 utan skrivarens marginaler.
- Ⓔ Portlanden painatuksen jälkeen reunat eivät saa näkyä.
- Ⓖ Udskriv venligst i målestoksforhold 1 uden printermarginer.
- Ⓖ Favor imprimir escala 1 sem as margens da impressora.
- Ⓖ Ὡς παρακάτω τυπώστε την κλίμακα 1 μέσα στα περιθώρια του εκτυπωτή.

Instructions
Notice de montage
Bauanleitung
Istruzioni di montaggio
Instrucciones de montaje
Instruções de montagem
Monteringsanvisning
Kokoamisohje
Monteringsinstruktioner
Montagehandleiding
Οδηγίες συναρμολόγησης.
Инструкции



USA Many of the models and component parts are unique and original designs which are the property of MECCANO. They are protected by national legislation as industrial designs, trademarks and/or copyrights throughout many countries. For detailed information, please contact: MECCANO. Meccano shall have no responsibility for (I) failure to follow instructions, (II) use of parts for any purpose other than as specified in the instructions (III) any alteration of any parts or components. MECCANO respects children's safety: all models are tested by children.

F De nombreux modèles et pièces sont des créations originales, propriétés de MECCANO et sont protégés par les législations nationales sur les dessins de modèles, marques et/ou droits d'auteurs. Pour toute information, merci de contacter: MECCANO. La responsabilité de MECCANO ne saurait être engagée en cas d'accident survenu à la suite (I) de non respect des instructions de montage (II) d'une utilisation des pièces autre que celle prévue dans le notice (III) d'une altération ou de la modification des pièces. La société MECCANO respecte la sécurité des enfants: ses modèles sont testés par des enfants.

D Zahlreiche Modelle und Teile sind Erfindungen und Eigentum der Firma MECCANO. Sie sind durch Inland-Gesetze über Zeichnungen und Modelle sowie Warenzeichen und/oder Urheberrechte geschützt. Für zusätzliche Auskünfte wenden Sie sich bitte an: MECCANO. Die Firma Meccano haftet nicht für Unfälle, die aus der (I) Nichtabhaltung der Bauanleitung, der (II) Verwendung anderer als in der Bauanleitung angegebenen Teile oder der (III) Änderung oder Modifikation der Teile resultieren. Alle Modelle der Firma Meccano wurden von Kindern getestet und entsprechen den Sicherheitsnormen.

I Numerosi modelli a pezzi sono creazioni originali della MECCANO e sono protetti dalle legislazioni nazionali sui disegni a modelli, marchi e/o diritti d'autore. Per qualsiasi informazione, vogliate prendere contatto con: MECCANO. Meccano declina ogni responsabilità in caso d'incidenti sopravvenuti in seguito (I) o a non rispetto delle istruzioni di montaggio (II) all'utilizzo dei pezzi, per funzioni diverse da quelle previste nel manuale (III) alterazione e/o modifica dei pezzi. La società MECCANO rispetta la sicurezza dei bambini: i suoi modelli vengono testati dai bambini stessi.

E Numerosos modelos y piezas son creaciones originales, propiedad de MECCANO y están protegidos por las legislaciones nacionales en lo que concierne a los dibujos y modelos, marcas y/o derechos de autor. Para cualquier información, sírvase ponerse en contacto con: MECCANO. MECCANO coreca de responsabilidade em caso de acidente da obra (I) e o incumprimento das instruções de montagem (II) ou a utilização das peças diferente a que se indica nas instruções (III) uma alteração o modificação de las piezas. La sociedad MECCANO respeta la seguridad de los niños: sus modelos están probados por niños.

P Vários modelos e peças são criações originais, propriedades da MECCANO e são protegidos pelas legislações nacionais relativas aos desenhos e modelos, às marcas e/ou aos direitos de autor. Para qualquer informação, é favor contactar: MECCANO. A Sociedade MECCANO não poderá ser responsabilizada pelos acidentes provocados: (I) pela falta de cumprimento das instruções de montagem (II) pelo uso indevido das peças ou (III) pela modificação ou alteração das peças. A Sociedade MECCANO respeita a segurança das crianças: os seus modelos foram testados por crianças.

S Många modeller och delar bildar en unik och originell formgivning vilken är MECCANO egendom. Dessa modeller och delar är skyddade genom lagstiftning såsom industriell formgivning, varumärke och/eller upphovsmanarätt i ett flertal länder. För mer detaljerad information, var vänlig och kontakta MECCANO. MECCANO fräntar sig allt ansvar i händelse av olycka till följd av (I) att monteringsinstruktionerna inte har respekterats (II) en annan användning av delarna än den som står i anvisningen (III) en förändring eller förändring av delarna. Företaget MECCANO respekterar barnsäkerheten: modellerna har testats av barn.

FIN Usesti mallit ja osat ovat MECCANO:n omistamia oleavia alkuperäisiä suunnitelmia. Ne ovat kansallilla lailla suojeitua heilitté mallitua, tavaramkekeja ja/tai kopioinnoikeksia. Pyydämme ottamaan yhteytta MECCANO:han kaikissa osuon liittyvissä kysymyksissä. MECCANO ei vastaa eikä kata seurauksista syistä sattuneita onnettomuuksia: (I) ohjeiden vastainen kokoaminen, (II) muiden kuin ohjeissa ehdotettujen osien käyttö, (III) osien muuttelu tai eri tarkoitukseseen käyttö. MECCANO-yhtiö huolehtii lasten turvallisuudesta: lapset ovat testanneet mallimme.

DK Vore mange modeller og dele er originale fremstillinger og ejes af MECCANO. Tegninger, modeller, fabriktionsmærker og oplysninger er lovbekyttede i hvert land. Yderligere oplysninger kan fås hos: MECCANO. MECCANO frsiger sig ethvert ansvar, sftromt der er sket uheld forrsaget af (I) at monteringsinstruktionerne ikke er blevet overholdt, (II) at delene er blevet brugt til andre formål, og dem der er beskrevet i betjeningsvejledningen, (III) eller at delene er blevet beskadiget eller ændret, MECCANO overholder sikkerhedsreglerne for barn: Alle modeller testes af børn.

NL Veel modellen en onderdelen zijn originele ontwerpen en eigendom van MECCANO en worden beschermd door de nationale wetgeving op tekeningen en modellen, merken en/of auteursrechten. Voor informatie gelieve contact op te nemen met MECCANO. De verantwoordelijkheid van MECCANO is uitgesloten in geval van ongevallen voortvloeiend uit het niet naleven van de montage-instructies (I), uit het gebruik van andere onderdelen dan die zoals vermeld in de handleiding (II) of uit het veranderden of modificeren van de onderdelen (III). De firma MECCANO neemt de veiligheid van de kinderen in acht: de modellen zijn door kinderen getest.

GR Πολλά μοντέλα και ανταλλακτικά είναι αυθεντικά, ιδιοκτησία της MECCANO και προστατεύονται από τις εθνικές νομοθεσίες για τα μοντέλα και τα διπλώματα ευρεσιτεχνίας για κάθε πληροφορία για κάθε πληροφορία παρακαλούμε απευθυνθείτε στη MECCANO. Η ευθύνη της MECCANO δεν δεσμεύεται σε περίπτωση ατυχημάτων που έγινε συνέχεια (I) μη σεβασμού των οδηγιών συναρμολόγησης (II) χρήσης των τεμαχίων διαφορετική από αυτήν που προτείνεται στις οδηγίες (III) καταστροφή ή αλλαγή των τεμαχίων. Η εταιρεία MECCANO σέβεται την ασφάλεια των παιδιών: τα μοντέλα της δοκιμάζονται από παιδιά.

RUS Многие модели и детали набора являются уникальными. Их оригинальная концепция является собственностью компании MECCANO. Модели защищены законодательством различных стран в качестве торговой марки промышленного дизайна или на основании закона об авторских правах. Для получения более подробной информации, пожалуйста, свяжитесь с представителем MECCANO. Meccano не несет ответственности в случае: а) несоблюдения инструкции, б) использования деталей конструктора не по назначению, в) любой деформации деталей конструктора. MECCANO заботится о детской безопасности: все модели тестируются детьми.

Warning! Attention! Achtung! Attenzione! ¡Atención! Aviso! Warning! Varoitus!
Advarsel! Waarschuwing! Προειδοποίηση! Внимание! Varování! Táhelepanu!
Ísprėjimas! Figyelmeztetés! Twissija! Uwaga! Atenție! Pozor! Rabhadh! Uzmaniþu! Внимание!



- GB/USA** Warning! Choking Hazard. Contains small parts which could be swallowed. Not suitable for children under 3 years.
- FR** Attention! Danger d'étouffement. Contient des petites pièces pouvant être absorbées. Ne convient pas aux enfants de moins de 3 ans.
- D** Achtung! Verschluckungsgefahr. Enthält verschluckbare Kleinteile. Nicht für Kinder unter 3 Jahren geeignet.
- I** Attenzione, pericolo di soffocamento! Contiene pezzi piccoli che potrebbero essere ingoiati. Non adatto ai bambini sotto i 3 anni.
- E** ¡Atención! Riesgo de asfixia. Contiene piezas pequeñas que un niño podría tragarse. No conviene a los niños menores de 3 años.
- P** Aviso! Perigo de se engasgar. Contém peças pequenas que podem ser engolidas. Não aconselhável a crianças com menos de 3 anos.
- S** Warning! Risk för kvävning. Innehåller små delar som kan sväljas. Ej lämplig för barn under 3 års ålder.
- FIN** Varoitus! Tukehtumisvaara. Sisältää pieniä osia, jotka voidaan niellä. Ei soveltu alle 3-vuotiaille lapsille.
- DK** Advarsel! Fare for slugning. Indeholder små dele, som kan sluges. Ikke velegnet for børn under 3 år.
- NL** Waarschuwing! Verstikkingsgevaar. Bevat kleine onderdelen die kunnen worden ingeslikt. Niet geschikt voor kinderen onder 3 jaar.
- GR** Προειδοποίηση! Κίνδυνος πνιγμού. Περιέχει μικρά εξαρτήματα που θα μπορούσαν να καταποθούν. Ακατάλληλο για παιδιά κάτω από 3 ετών.
- BULGARIAN** Внимание! Опасност от задушаване. Съдържа малки части, които могат да бъдат погълнати. Не е подходящо за деца под 3 години.

- CZECH** Varování! Nebezpečí udušení. Obsahuje malé díly, které by mohly být spolknuty. Nevhodné pro děti do 3 let.
- ESTONIAN** Tähelepanu! Lämbumisoh. Sisaldab väikeseid osi, mida saab alla neelata. Ei sobi alla 3. aasta vanustele lastele.
- LITHUANIAN** Įspėjimas! Uždusimo pavojus. Yra smulkii dalių, kurias galima nuryti. Netinka vaikams iki 3 metų.
- HUNGARIAN** Figyelmeztetés! Fulladásveszély. Apró alkatrészeket tartalmaz, amelyeket a gyermekek lenyelhetnek. 3 évesnél fiatalabb gyermekek számára nem alkalmas.
- MALTESE** Twissija! Periklu li wiehd jifga. Fih partijiet zghar li jistghu jinbelghu. Mhuwiex adattat ghaf tjal izghar minn 3 snin.
- POLISH** Uwaga! Ryzyko uduszenia. Zawiera male czesći, które mogą zostać połknięte. Produkt nieodpowiedni dla dzieci poniżej 3 lat.
- ROMANIAN** Atenție! Pericol de sufocare. Conține piese mici care pot fi înghițite. Interzis copiilor sub 3 ani.
- SLOVAK** Pozor! Nebezpečstvo udušenia. Obsahuje malé diely, ktoré je možné prehltnúť. Nie je vhodné pre deti mladšie ako 3 roky.
- SLOVENIAN** Pozor! Nevarnost zadušitve. Vsebuje majhne dele, ki jih je možno zaužiti. Ni primerno za otroke, mlajše od 3 let.
- IRISH** Rabhadh! Guais Tachta. Piosáí beaga ann a fhéadfhadh a bheith insúite. Níl an bréagán seo oiriúnach do pháistí atá níos óige ná trí bhliain d'aois.
- LATVIAN** Uzmaniþu! Nosmakšanas draudi. Satur sikas detaļas, kuras var tikt norītas. Nav piemērots bērniem, kas jaunāki par 3 gadiem.
- RUSSIA** Внимание! Возможен риск удушья. В наборе имеются мелкие детали, которые легко проглотить. Противопоказан детям младше 3 лет.



363, avenue de Saint Exupéry, 62100 Calais - France
<http://www.meccano.com> <http://www.erektor.us>
© 12/2012 MECCANO
©MECCANO and EREKTOR are exclusive trademarks of MECCANO
All Rights Reserved.
© 2013, Epic Games, Inc. All Rights Reserved. Epic, Epic Games, the Epic Games logo, Gears of War, Gears of War 3, Gears of War: Judgment, Marcus Fenix and Crimson Omen Logo are trademarks or registered trademarks of Epic Games, Inc. in the United States of America and elsewhere.



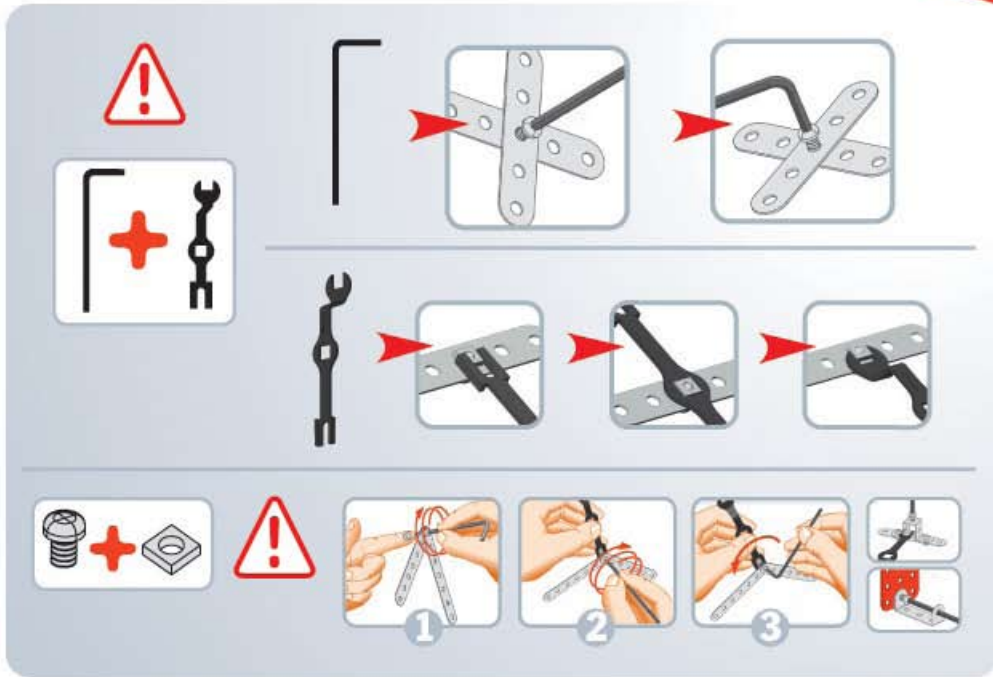

GARRON PADUK

LOCUST GRENADE

MARZKA

LANCER

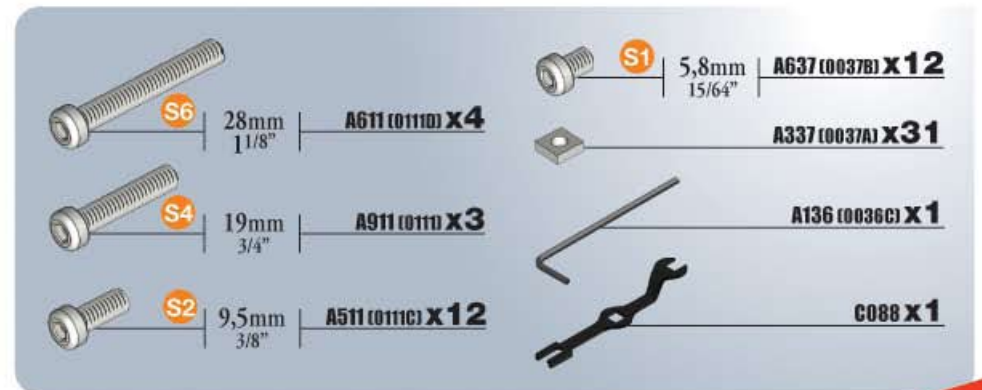
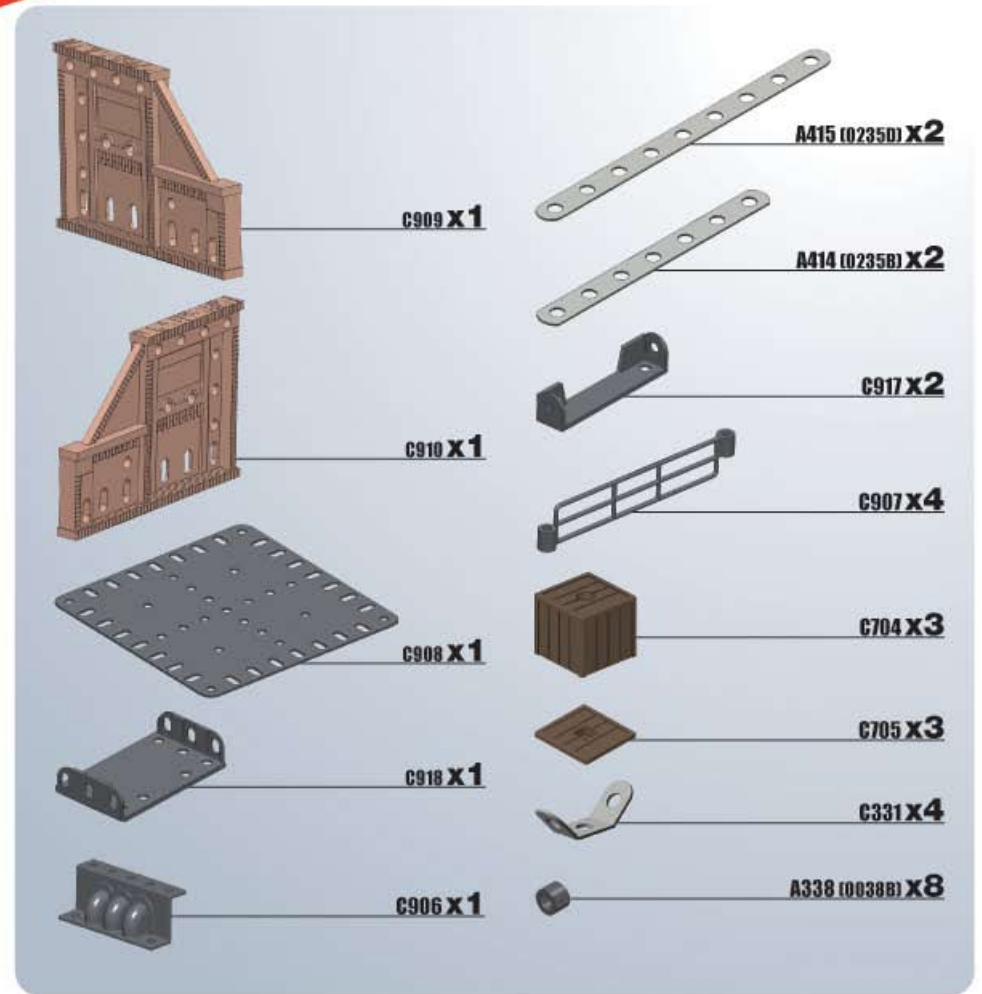



1

	x2
	x2
	x2
	x2

	1:1
--	-----

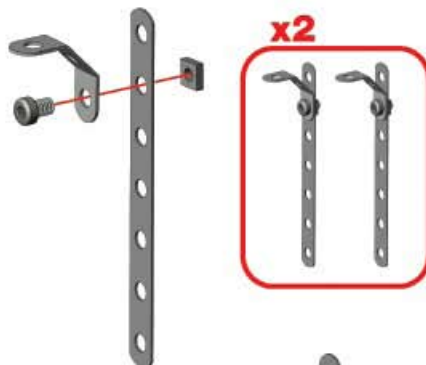

2

	x2
	x2
	x2
	x2

	1:1
--	-----

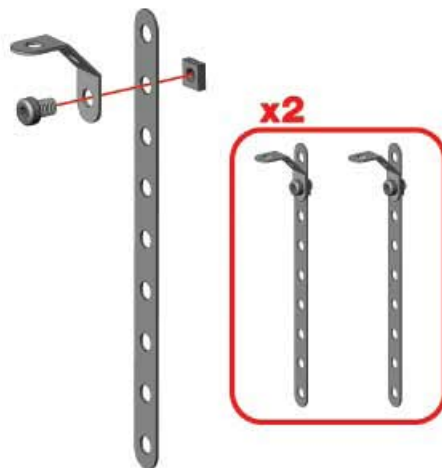

3 (2)+

	x1
	x1
	x1

	1:1
--	-----

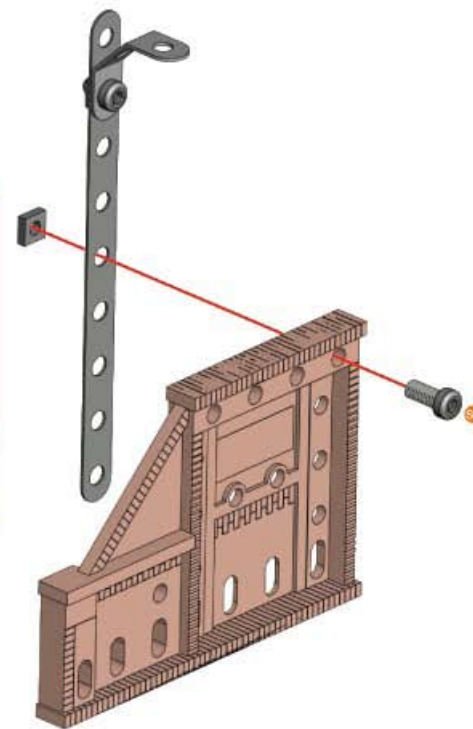

4 (1)+(3)+

	x1
	x1
	x2

	1:1

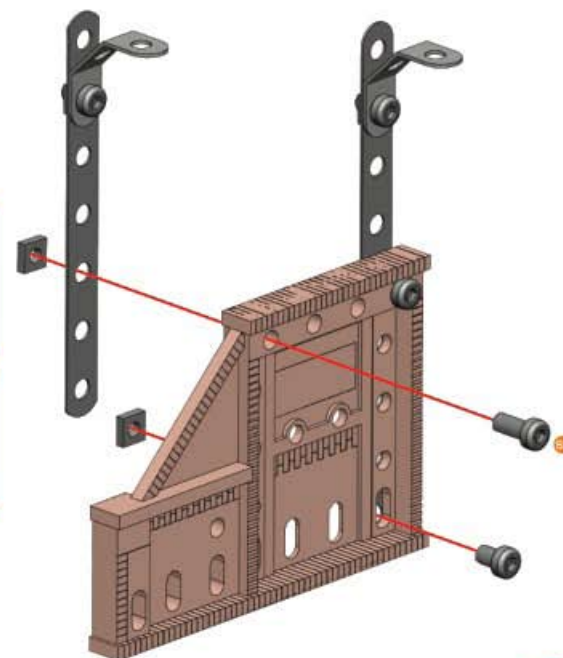

5

-  x1
-  x1
-  5,8mm | 15/64" x2
-  x2

-  S1 1:1



7

-  x1
-  9,5mm | 3/8" x1
-  x1

-  S2 1:1

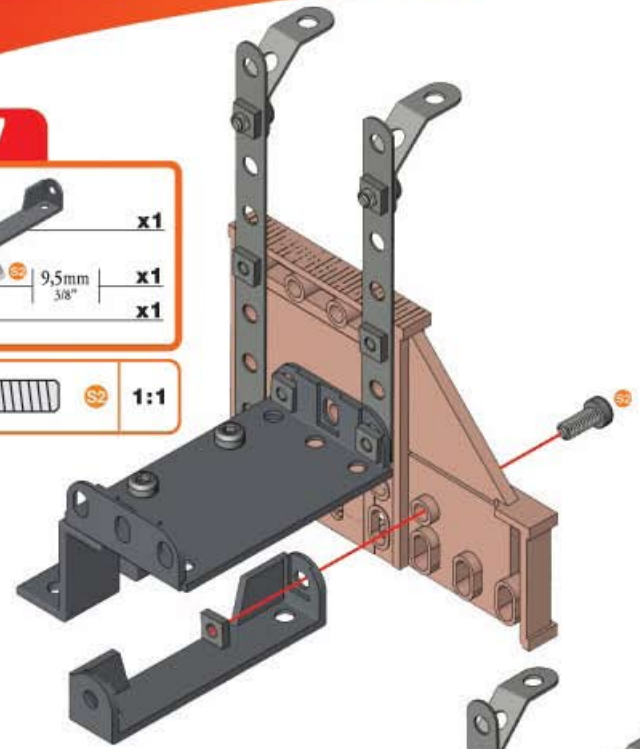

6

④+⑤+

-  5,8mm | 15/64" x2
-  x2

-  S1 1:1

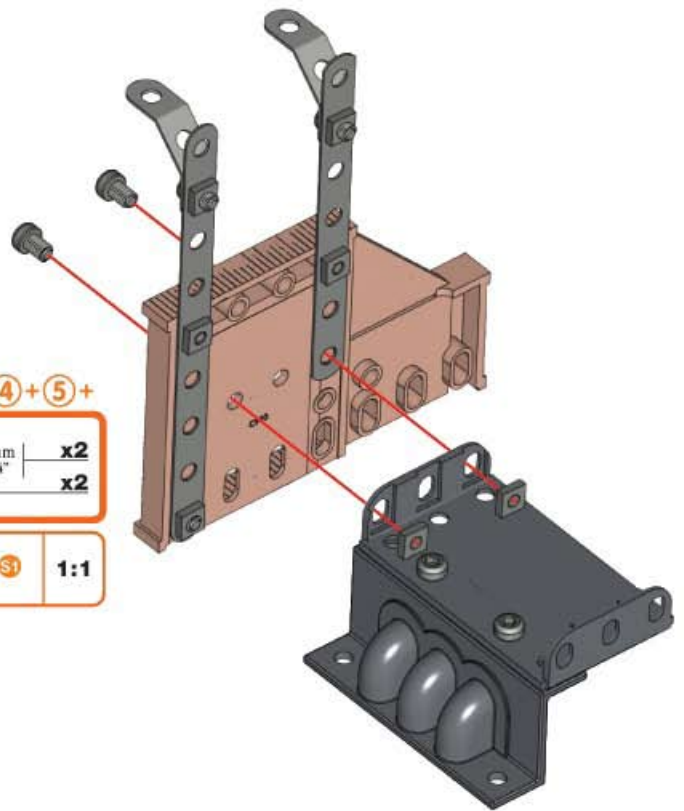

8

-  x1
-  9,5mm | 3/8" x1
-  x1

-  S2 1:1

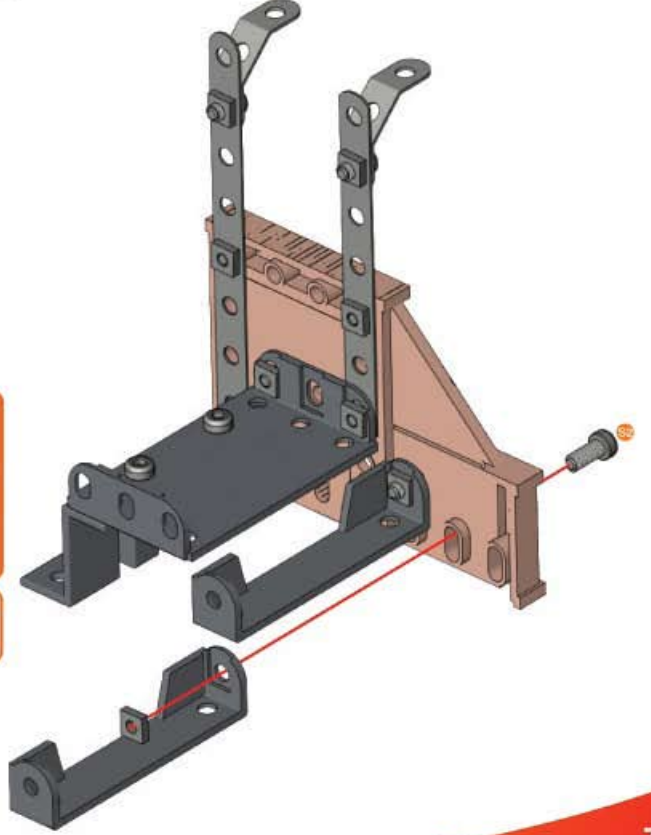

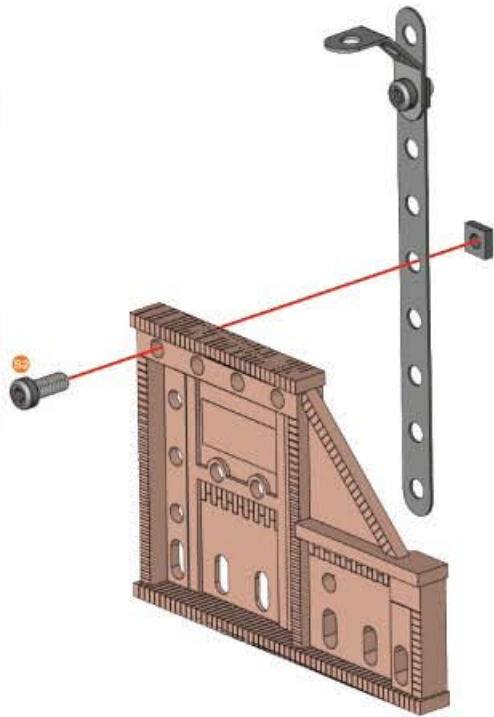
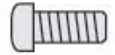
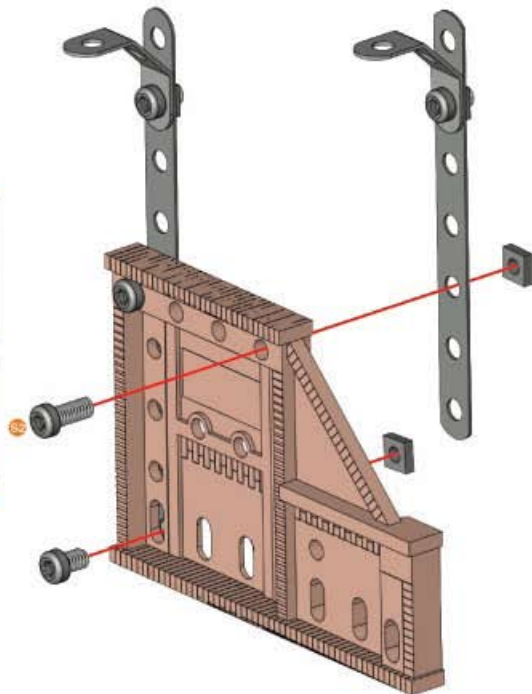
9**2+****x1**9,5mm
3/8" **x1****x1****S2** **1:1****11****8+10+**5,8mm
15/64" **x1****x1****S1** **1:1****10****1+9+**9,5mm
3/8" **x1**5,8mm
15/64" **x1****x2****S2****S1** **1:1****12**9,5mm
3/8" **x2**5,8mm
15/64" **x1****x3****S2****S1** **1:1**

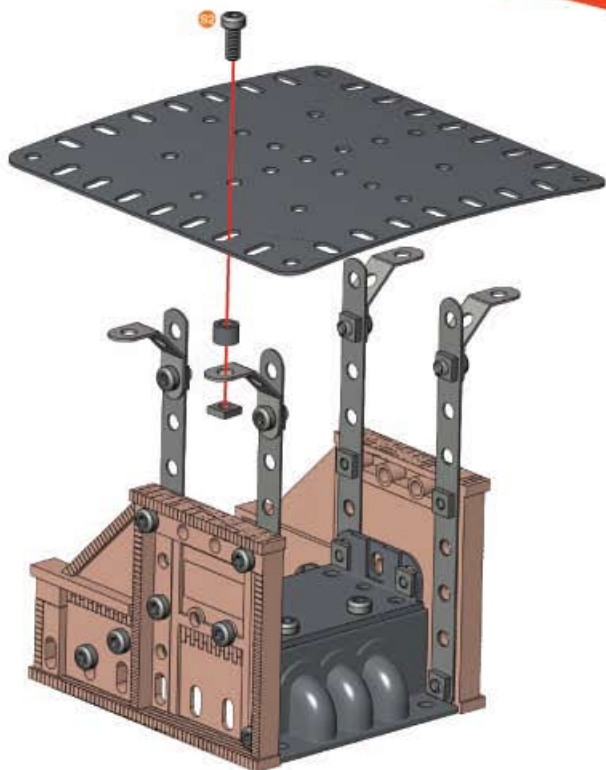
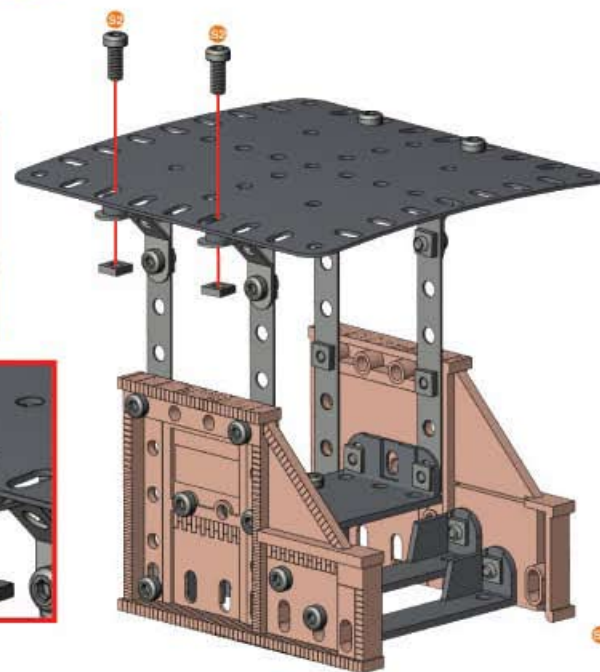
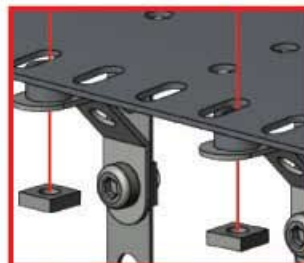
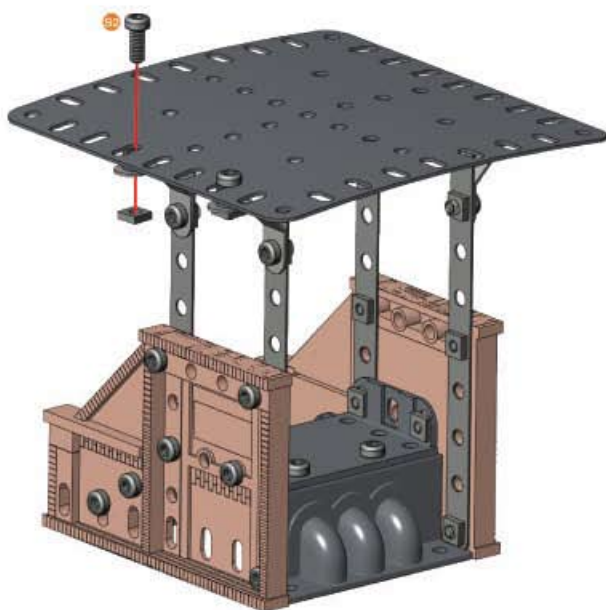
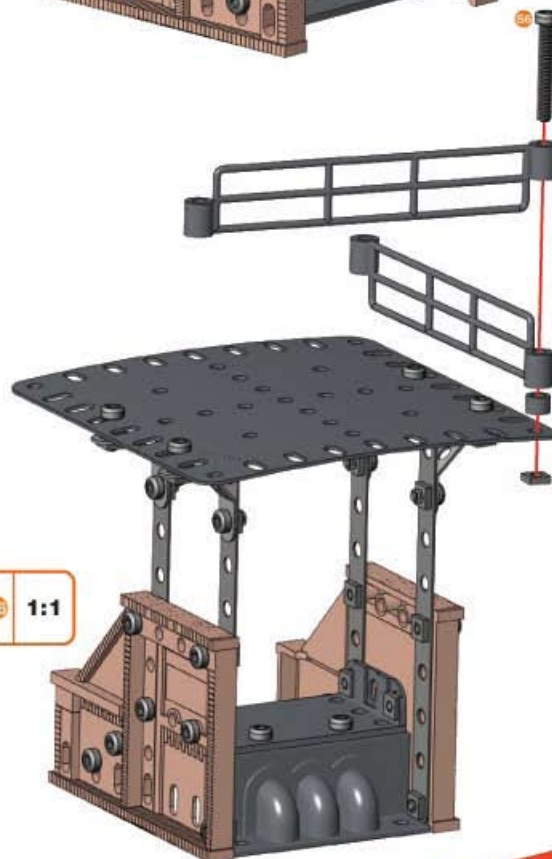
13**15****14****16**

17

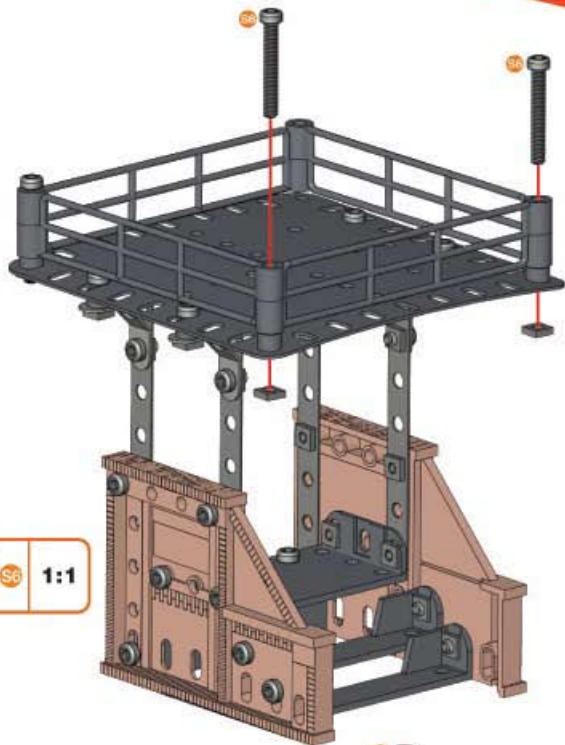



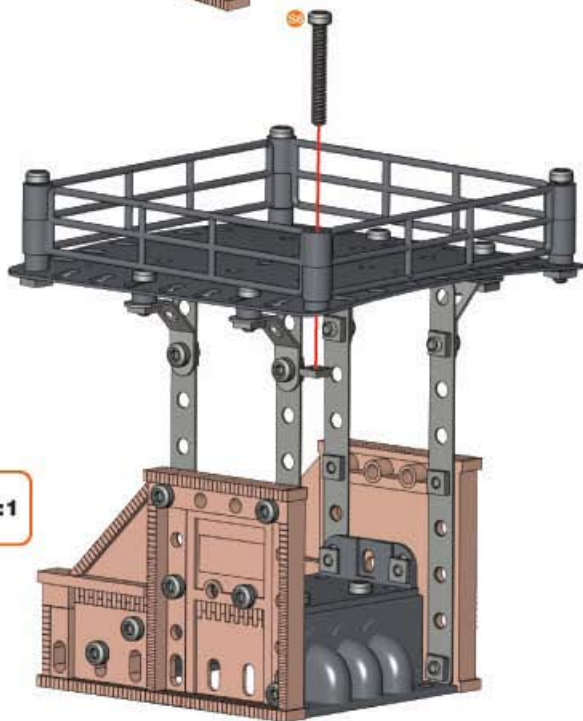

18

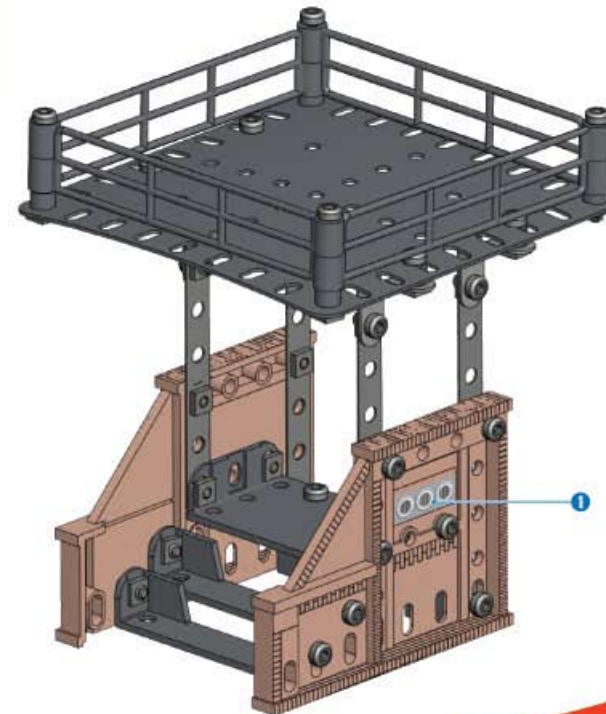
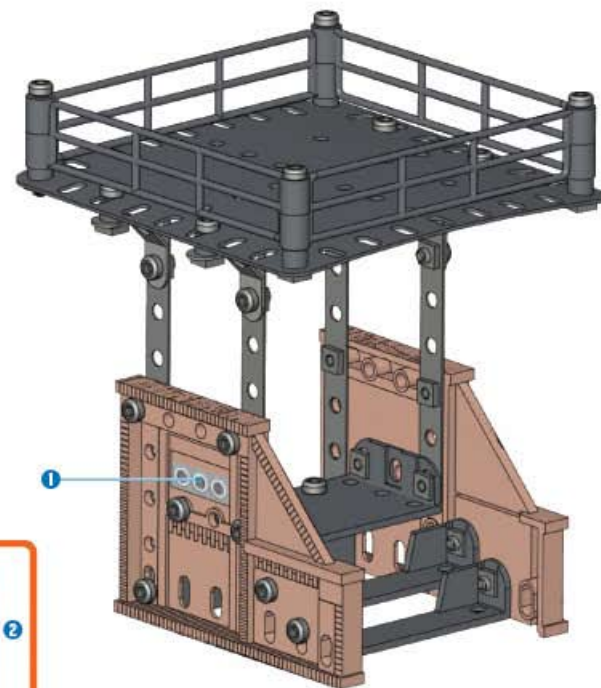
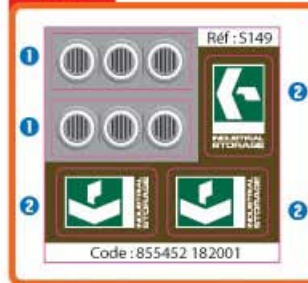

19



20

-  x3
-  x3
-  19mm x3
-  3/4" x3

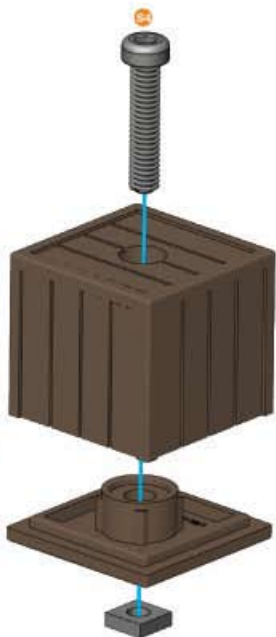

x3



21

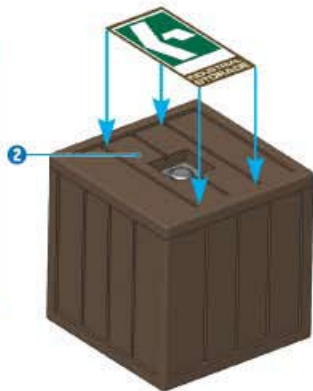
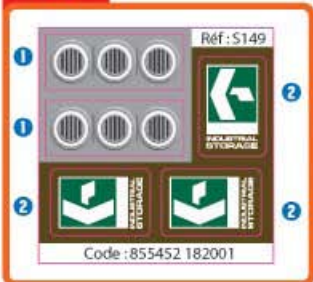

x3

