

Instructions
 Notice de montage
 Bauanleitung
 Istruzioni di montaggio
 Instrucciones de montaje
 Instruções de montagem
 Monteringsanvisning
 Kokoamisohje
 Monterings instruktioner
 Montagehandleiding
 Οδηγίες συναρμολόγησης.
 Инструкции



- FR Merci d'imprimer à échelle 1 sans les marges de l'imprimante.
- GB Please print at scale 1 without the printer margins.
- DE Den Maßstab 1 bitte randlos drucken.
- IT Stampare la scala 1 senza i margini della stampante.
- ES Imprimir a escala 1 sin los márgenes de la impresora.
- P E favor imprimir escala 1 sem as margens da impressora.
- S Skriv ut i skala 1 utan skrivarens marginaler.
- FI Portaiden painatuksen jälkeen reunat eivät saa näkyä.
- DK Udskriv venligst i målestoksforhold 1 uden printermarginer.
- NL E favor imprimir escala 1 sem as margens da impressora.
- GR Σας παρακαλώ τυπώστε την κλίμακα 1 μέσα στα περιθώρια του εκτυπωτή.
- RU Пожалуйста, печатайте в масштабе 1:1 без отступов от края.

MULTIMODELS™

MOTORISED / MOTORISÉ

8+
7555



2 x AA 1.5V
 BATTERIES NOT INCLUDED / PILAS NO INCLUIDAS /
 BATTERIEN NICHT ENTHALTEN / BATTERIEN
 NIET INBEVATTEN / BATTERIE NON INCLUSE /
 БАТЭРІЯС НАО ІНКЛУІСАС / ЭЛЕМЕНТЫ
 ПИТАНИЯ НЕ ВХОДЯТ В КОМПЛЕКТ

7
MODELS



+18
MODELS



- www.meccano.com
- www.meccano.fr
- www.erecator.us



A651 x1



C371 x2



C369 x2



A173 (0073A) x2



A851 (0051G) x1



B484 x1



A045 (0045) x4



A187 (0187C) x4



A327 (0027P3P) x1



A128 (0028P3P) x1



A627 (0022BP3P) x1



A202 (0002) x4



A302 (0002A) x2



A415 (0235D) x2



A414 (0235B) x1



A203 (0003) x4



A105 (0005) x3



A105 (0005) x2



A286 (0090) x2



A252 (0051A) x2



A248 (0048) x3



A126 (0126) x2



A233 (0133C) x2



A506 (0006A) x2



A713 (012D) x3



A212 (0212) x2



A898 (0040B) x1



A334 (0110C) x1



C372 x4



A177 (0177A) x2



B953 x2



A423 (0260F) x2



A712 (0012C) x8



A012 (0012) x10



A313 (0213D3P) x1



A326 (0026P3P) x1



A444 (0144C) x2



A025 (0025B3P) x2



A138 (0038) x5



A337 (0037A) x90



A737 (0037H) x4



A623 (0023C3P) x4

A238 (0038A) x25

A359 (0059A) x2

A338 (0038B) x4

A259 (0059C) x19



C375 x2



130mm
5 1/8" | **A315 (0315) x2**



115mm
4 1/2" | **A427 (0315A) x2**



100mm
3 15/16" | **A428 (0315B) x2**



65mm
2 1/2" | **A117 (0016A) x1**



50mm
2" | **A317 (0317) x1**



A695 (0186C) x1



A696 (0186H) x2



B4 | 38,1mm
1 1/2" | **B696 x2**



S5 | 25,4mm
1" | **A912 (0111E) x1**



B2 | 19mm
3/4" | **A447 (0147F) x2**



B1 | 14,7mm
37/64" | **A247 (0147D) x8**



S3 | 12mm
1/2" | **A411 (0111A) x5**



S2 | 9,5mm
3/8" | **A511 (0111C) x2**



S1 | 5,8mm
15/64" | **A637 (0037B) x67**

A136 (0036C) x1

C088 x1

CONSTRUCTION TIPS
 LES ASTUCES DE CONSTRUCTION
 KONSTRUKTIONSTIPPS
 LE ASTUZZE DELLA COSTRUZIONE
 DICAS PARA A MONTAGEM
 KONDOPOMENON KIKAT
 BYSGEMEREN
 ET PAR TIPS TI BYGGARBEJDET
 DE FINE KNEPES VAN HET BOUWEN
 Το έξιτο κόλπο κατασκευής
 рекомендация по сборке

3

4

GB USA Standard batteries must not be recharged. Rechargeable batteries must be removed from the toy before being recharged (if it is possible to remove them). Rechargeable batteries must only be recharged under adult supervision (if it is possible to remove them). Do not mix different types of batteries together or new with old rechargeable/ non rechargeable batteries. Only batteries of the recommended type or a similar type should be used. Batteries must be fitted in accordance with their instructions. Remove used batteries from the toy. Battery terminals must not be short-circuited. Please keep instructions. Do not mix old and new batteries. Do not mix alkaline, standard (carbon-zinc), or rechargeable (nickel-cadmium) batteries.

F Les piles ne doivent pas être rechargées. Les accumulateurs doivent être enlevés du jouet avant d'être chargés (s'ils peuvent être enlevés). Les accumulateurs ne doivent être chargés que sous la surveillance d'un adulte (s'ils peuvent être enlevés). Différents types de piles ou accumulateurs ou des piles ou accumulateurs neufs et usagés ne doivent pas être mélangés. Seuls des piles ou accumulateurs du type recommandé ou d'un type similaire doivent être utilisés. Les piles et accumulateurs doivent être mis en place en respectant la polarité. Les piles et accumulateurs usagés doivent être enlevés du jouet. Les bornes d'une pile ou d'un accumulateur ne doivent pas être mises en court-circuit. Indications à conserver. Différents types de piles ou accumulateurs ou des piles ou accumulateurs neufs et usagés ne doivent pas être mélangés.

D Die Batterien dürfen nicht wieder aufgeladen werden. Die Akkus müssen vor dem Nachladen aus dem Spielzeug genommen werden (wenn sie ausgebaut werden können). Die Akkus dürfen nur unter Aufsicht eines Erwachsenen nachgeladen werden (wenn sie ausgebaut werden können). Unterschiedliche Arten von Batterien und Akkus oder neue und gebrauchte Batterien bzw. Akkus dürfen nicht zusammen verwendet werden. Es dürfen nur Batterien bzw. Akkus der empfohlenen Art oder einer ähnlichen Art verwendet werden. Beim Einsetzen der Batterien bzw. Akkus auf die richtige Polung achten. Verbrauchte Batterien bzw. Akkus bitte aus dem Spielzeug entfernen. Die Klammern der Batterien bzw. Akkus dürfen nicht kurzgeschlossen werden. Diese Anweisungen bitte aufbewahren. Unterschiedliche Arten von Batterien und Akkus oder neue und gebrauchte Batterien bzw. Akkus.

I La pile non devono essere ricaricate. Gli accumulatori devono essere tolti dal giocattolo prima di essere caricati (se è possibile toglierli). Gli accumulatori devono essere caricati solo sotto la sorveglianza di un adulto (se è possibile toglierli). Non possono essere mescolati tipi diversi di pile o di accumulatori oppure pile o accumulatori nuovi e usati. Si devono usare solo pile o accumulatori del tipo raccomandato o di un tipo simile. Le pile e gli accumulatori devono venire sistemati rispettando la polarità. Le pile e gli accumulatori usati devono essere tolti dal giocattolo. I morsetti di una pila o di un accumulatore non devono essere messi in cortocircuito. Conservare queste istruzioni. Non possono essere mescolati tipi diversi di pile o accumulatori oppure pile o accumulatori nuovi e usati.

E Las pilas no deberán recargarse. Habrá que retirar los acumuladores del juguete antes de proceder a recargarlos (si es que pueden retirarse). Los acumuladores sólo se recargarán bajo la vigilancia de una persona adulta (si es que pueden retirarse). No deberán mezclarse diferentes tipos de pilas o acumuladores o de pilas o acumuladores nuevos y usados. Sólo se utilizarán pilas o acumuladores del tipo recomendado o de un tipo similar. Las pilas y acumuladores deberán colocarse respetando la polaridad. Deberán retirarse del juguete las pilas y acumuladores usados. Lors bornes de una pila o de un acumulador ne deberán disponerse nunca en posición de cortocircuito. Conserve estas indicaciones. No deberán mezclarse diferentes tipos de pilas o acumuladores o de pilas o acumuladores nuevos y usados.

P As pilhas não devem ser novamente carregadas. Os acumuladores devem ser removidos do brinquedo antes de serem carregados (caso possam ser removidos). Os acumuladores devem ser carregados apenas sob cuidados de um adulto (caso possam ser removidos). Diferentes tipos de pilhas ou acumuladores ou pilhas ou acumuladores novos já utilizados não devem ser misturados. Pilhas ou acumuladores do tipo recomendado ou de um tipo similar poderão ser utilizados. As pilhas e acumuladores devem ser inseridos, respeitando a polaridade. Devem ser removidos do brinquedo as pilhas e acumuladores já utilizados. Os pólos de uma pilha ou de um acumulador não devem ser curto-circuitados. Indicações a conservar. Diferentes tipos de pilhas ou acumuladores ou pilhas ou acumuladores novos já utilizados não devem ser misturados.

S Batterierna skall inte laddas om. Akkumulatorbatterierna skall tas av från leksaken innan de laddas (om de kan tas av). Akkumulatorbatterierna skall endast laddas under uppsikt av en vuxen (om de kan tas av). Olika typer av batterier eller akkumulatorbatterier skall inte blandas. Nya och använda batterier eller akkumulatorbatterier skall inte blandas. Använd endast rekommenderade typer eller likartade typer av batterier eller akkumulatorbatterier. Batterierna och akkumulatorbatterierna skall sättas i med hänsyn till polerna. Använda batterier och akkumulatorbatterier skall tas av från leksaken. Kontaktterna på ett batteri eller ett akkumulatorbatteri skall inte kortslutas. Bevara anvisningarna. Diferentes tipos de pilhas ou acumuladores ou pilhas ou acumuladores novos já utilizados não devem ser misturados.

FIN Paristoja ei saa ladata uudelleen. Akut on otettava ulos leikkikalusta ennen lataamista (jos se on mahdollista). Akut saa ladata vain aikuisen valvonnassa (jos ne voidaan ottaa ulos). Erityyppisiä paristoja tai akkuja ei saa käyttää yhdessä, samoin ei saa sekoiteta akkuja ja uusia ja vanhoja paristoja. Vain suositeltuja akku- tai paristotyyppiä saa käyttää tai tyyppejä, joilla on samat ominaisuudet. Paristo ja akut on asetettava paikoilleen niin, että navat tulevat oikeisiin suuntiin. Loppunkäytetyt paristot tai akut on otettava leikkikalusta ulos. Akun tai pariston napoja ei saa oikosulkea. Ohjeet on pidettävä tallessa. Erityyppisiä paristoja tai akkuja ei saa käyttää yhdessä, samoin ei saa sekoiteta akkuja ja uusia ja vanhoja paristoja.

DK Batterierne må ikke oplades. Akkumulatorbatterier skal tages ud af legetøjet, inden de lades op (hvis de kan tages ud). Akkumulatorbatterierne må kun lades op under opsyn af voksne (hvis de kan tages ud). Forskellige typer batterier og akkumulatorbatterier, eller nye og brugte batterier, må ikke blandes sammen. Der må kun anvendes batterier eller akkumulatorbatterier af den type der er anbefalet eller tilsvarende modeller. Batterier og akkumulatorbatterier skal vendes rigtigt (+/- polar). Brugte batterier og akkumulatorbatterier skal tages ud af legetøjet. Klemmerne på et batteri eller et akkumulatorbatteri må ikke kortsluttes. Disse instruktioner bør opbevares. Forskellige typer batterier og akkumulatorbatterier, eller nye og brugte batterier, må ikke blandes sammen.

NL De batterijen mogen niet weer opgeladen worden. De accu's moeten voor het laden uit het speelgoed verwijderd worden (indien ze verwijderd kunnen worden). Gebruik geen verschillende typen batterijen of accu's of gebruikte en nieuwe batterijen of accu's door elkaar. Gebruik alleen batterijen of accu's van het aanbevolen type of van een gelijkwaardig type. Let bij het plaatsen van de batterijen en accu's goed op de juiste polariteit. De verbruikte batterijen en accu's dienen uit het speelgoed verwijderd te worden. De aansluitingen van een batterij of van een accu mogen niet kortgesloten worden. Aanwijzingen om te bewaren. Gebruik geen verschillende typen batterijen of accu's of gebruikte en nieuwe batterijen of accu's door elkaar.

GR Οι μπαταρίες δεν πρέπει να επαναφορτίζονται. Οι συσσωρευτές πρέπει να αφαιρούνται από το παιχνίδι πριν τη φόρτιση (εάν μπορούν να αφαιρεθούν). Οι συσσωρευτές πρέπει να φορτίζονται μόνον υπό την επίβλεψη ενήλικα (εάν μπορούν να αφαιρεθούν). Δεν πρέπει να ανακατεύονται διάφοροι τύποι μπαταριών ή συσσωρευτών ή μπαταριών ή συσσωρευτών καινούριων και παλιών. Πρέπει να χρησιμοποιούνται μόνον μπαταρίες ή συσσωρευτές του συνιστώμενου τύπου ή παρόμοιου τύπου. Οι μπαταρίες και οι συσσωρευτές πρέπει να τοποθετούνται σύμφωνα με τη σωστή πόλωση. Οι παλιές μπαταρίες και οι παλιοί συσσωρευτές πρέπει να αφαιρούνται από το παιχνίδι. Οι πόλοι μιας μπαταρίας ή ενός συσσωρευτή δεν πρέπει να βραχυκυκλώνονται. Διατηρήστε τις οδηγίες. Δεν πρέπει να ανακατεύονται διάφοροι τύποι μπαταριών ή συσσωρευτών ή μπαταριών ή συσσωρευτών καινούριων και παλιών. Πρέπει να χρησιμοποιούνται μόνον μπαταρίες ή συσσωρευτές του συνιστώμενου τύπου ή παρόμοιου τύπου.

RUS Стандартные батареи нельзя заряжать. Аккумуляторные батареи должны быть извлечены из игрушки перед зарядкой (если их возможно извлечь). Аккумуляторы следует заряжать только под наблюдением взрослых (если батареи возможно извлечь). Не используйте различные типы батарей вместе или новые перезаряжаемые/неперезаряжаемые батареи со старыми. Следует использовать только батареи рекомендованного или аналогичного типа. Батареи должны быть установлены в соответствии с инструкциями. Необходимо извлекать использованные батареи из игрушки. Контакты батарей нельзя закорачивать. Сохраните инструкцию. Не используйте одновременно старые и новые батарейки. Не смешивайте щелочные, стандартные (угольно-цинковые) или перезаряжаемые (никель-кадмиевые) батарейки.

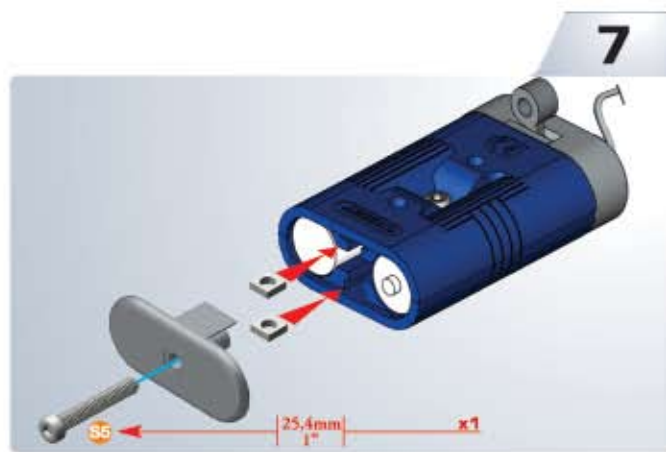
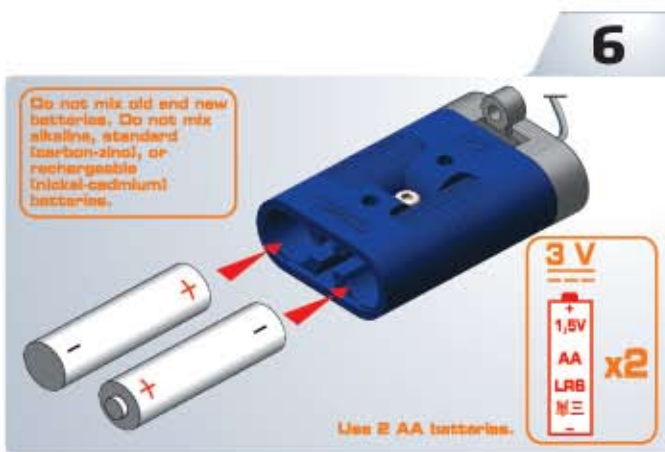
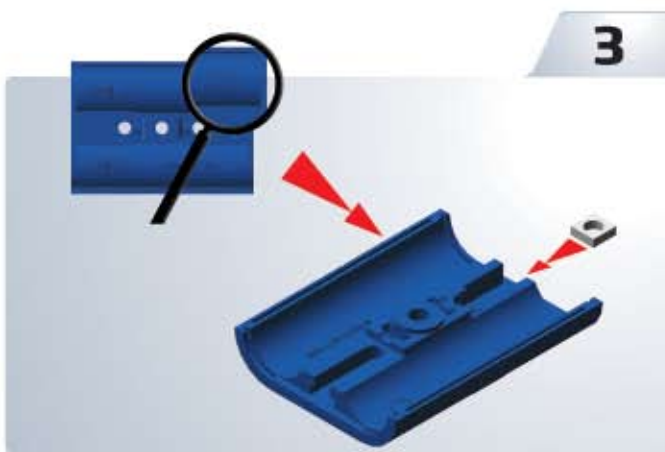
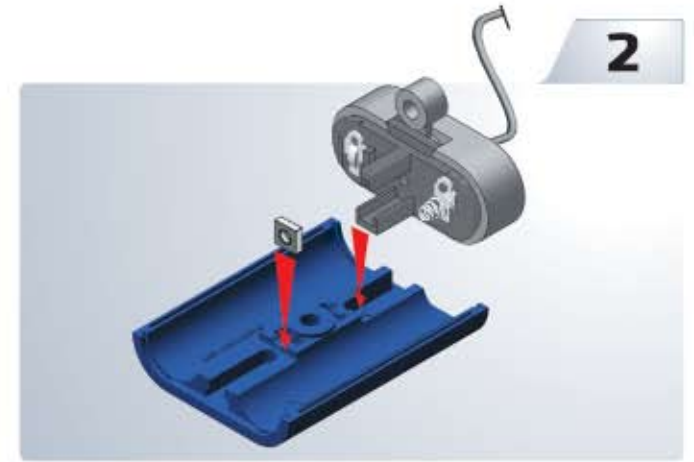
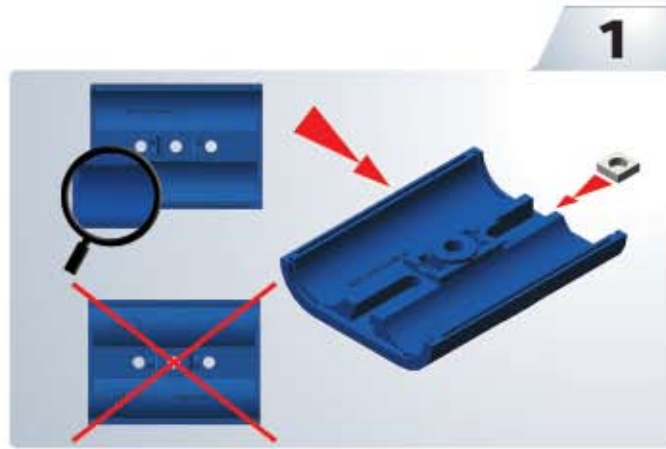



1

- x1
- x2
- 5,8mm | 15/64" x4
- x4

- S1 1:1
- Scale 1 Escala 1 Mittakaava 1
- Echelle 1 Schaal 1 Målestok 1
- Maßstab 1 Escala 1 Мәлімет 1
- Scala 1 Skala 1 масштаб 1

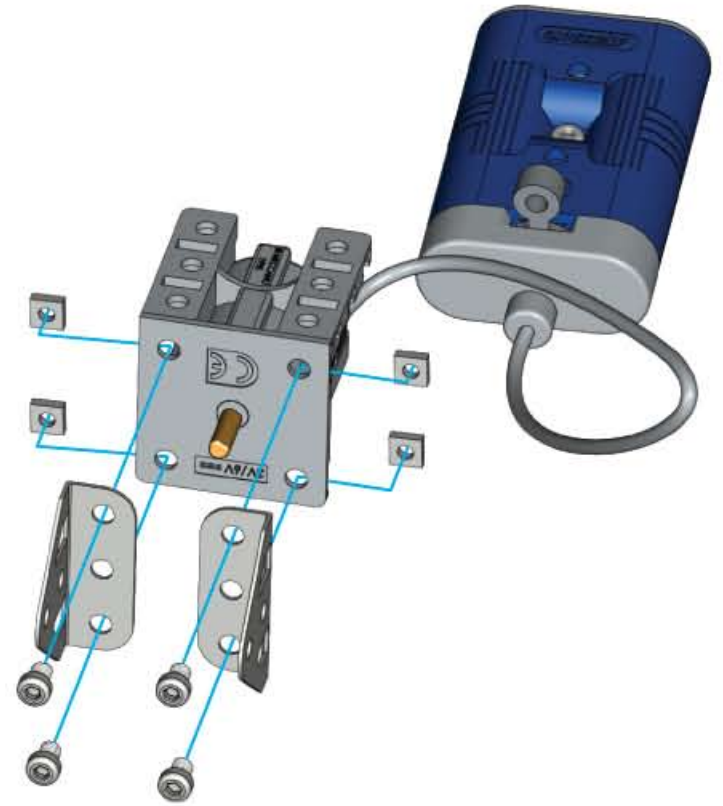

2

- x1
- x1

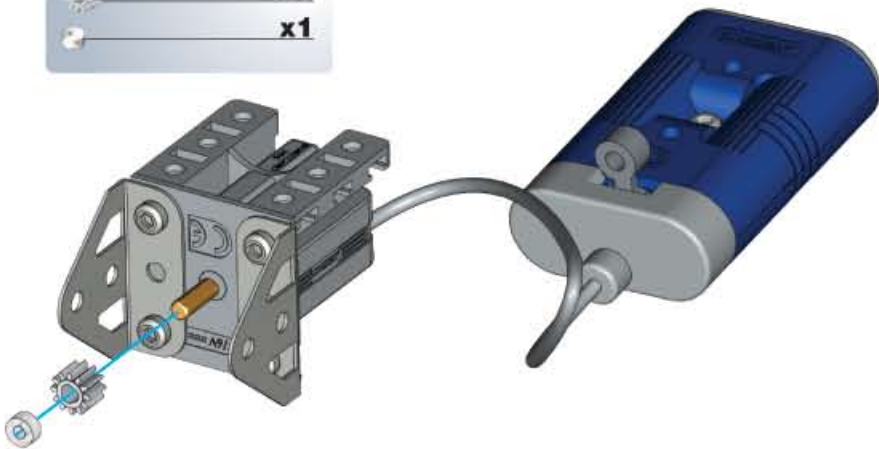

3

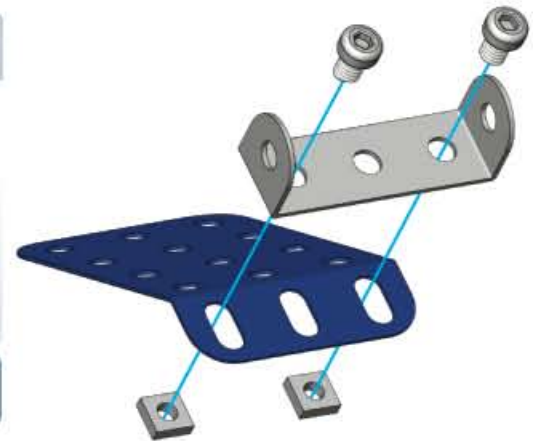

- x1
- x1
- 5,8mm | 15/64" x2
- x2

- S1 1:1





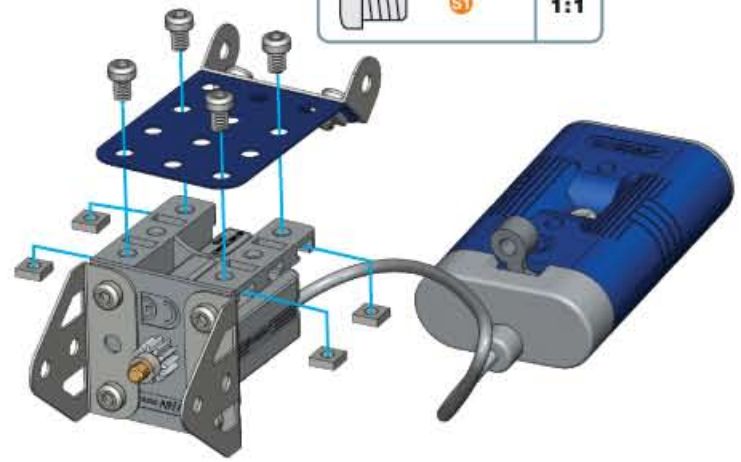

4

②+③+

	S1	5,8mm 15/64"	x4
			x4
	S1		1:1





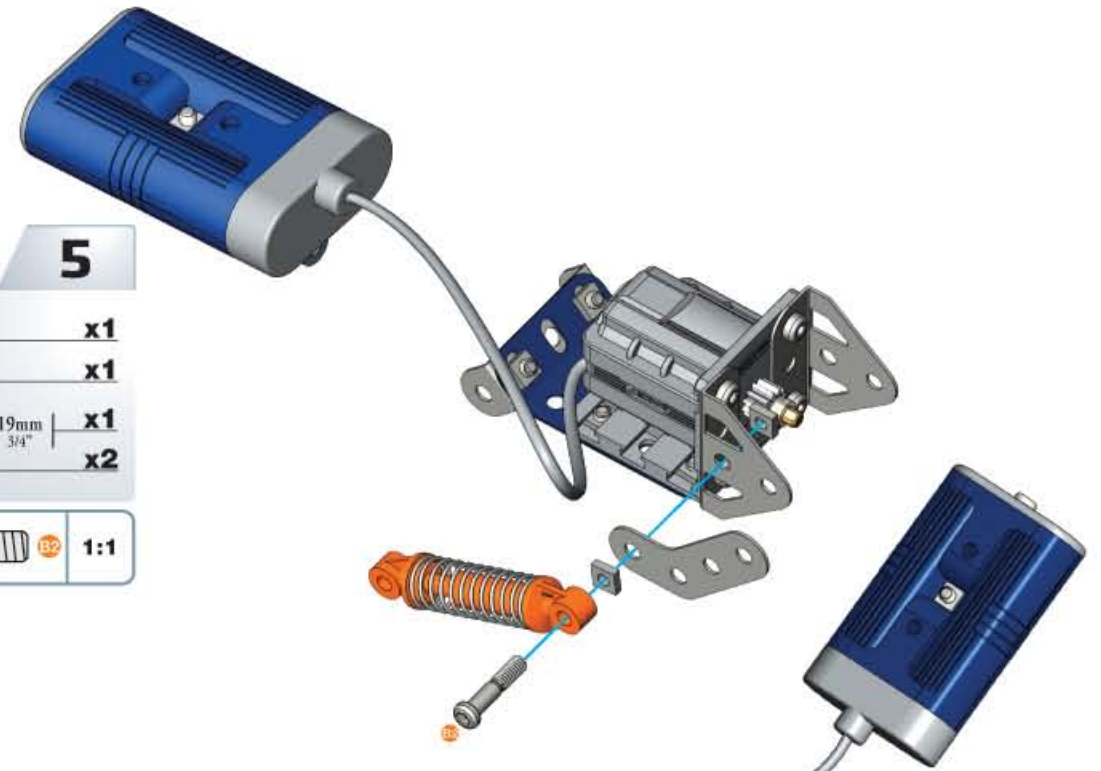

5

			x1
			x1
	B2	19mm 3/4"	x1
			x2
	B2		1:1









6

			x1
			x1
	B2	19mm 3/4"	x1
			x2
	B2		1:1



7

		50mm 2"	x1
			x1
			x1
			x2
			x2
			1:1

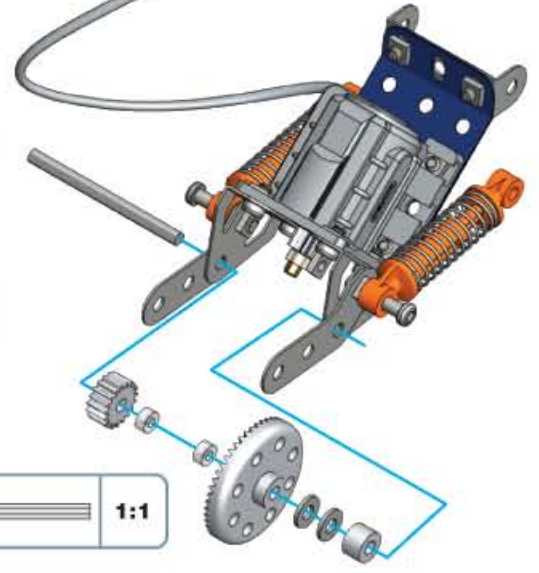

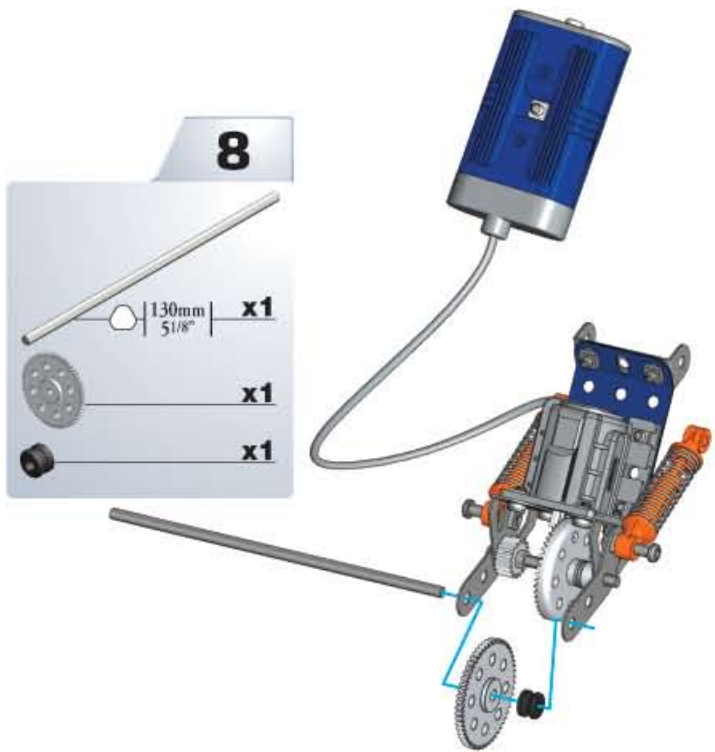

- 8**
- 130mm
5 1/8" x1
 - x1
 - x1

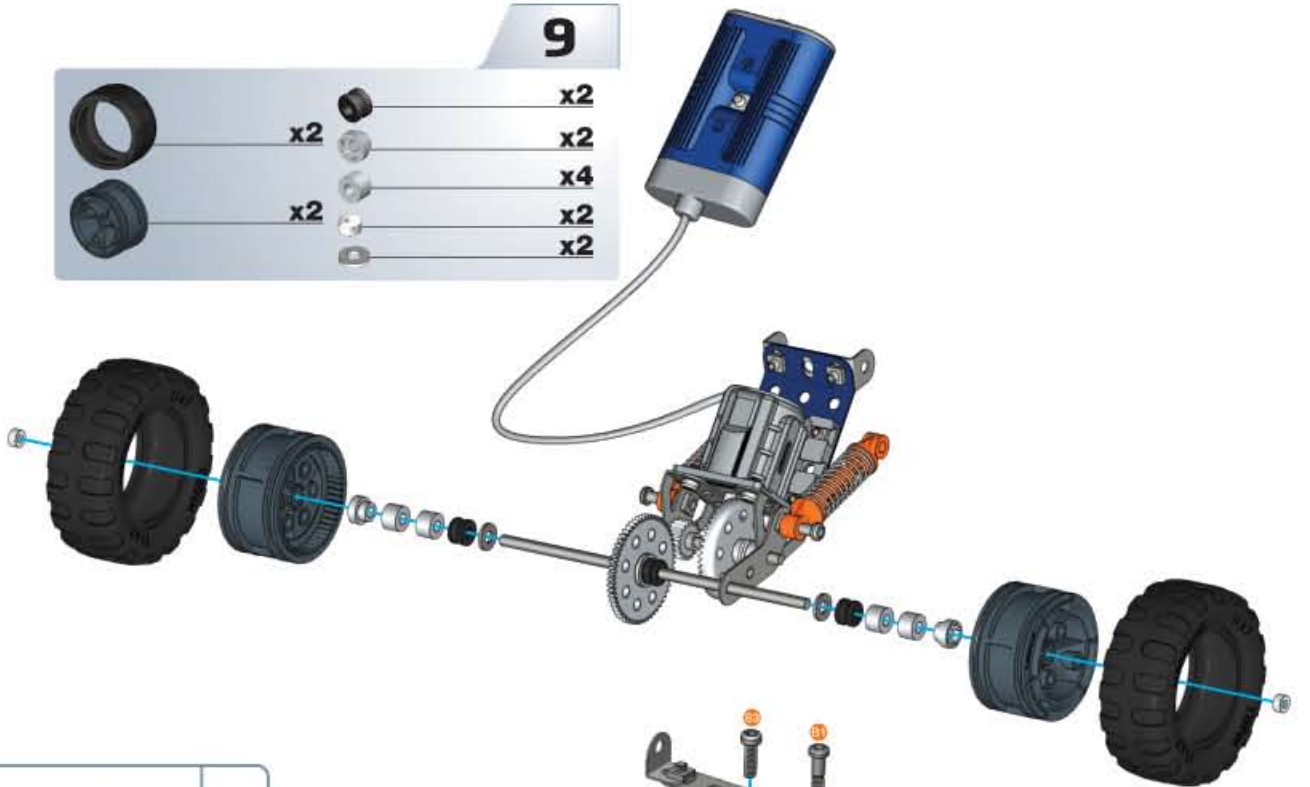

- 9**
- x2
 - x2
 - x2
 - x4
 - x2
 - x2

- 1:1

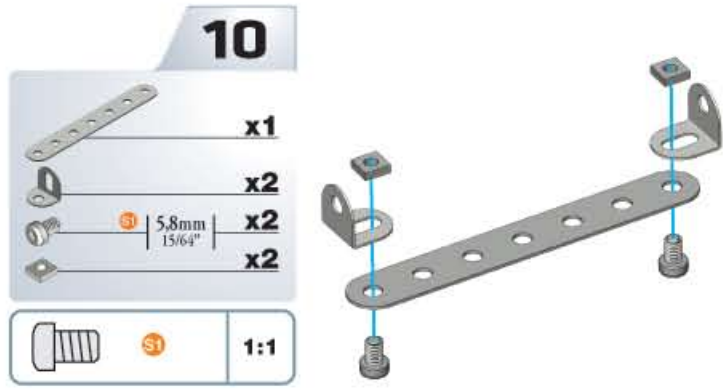

- 10**
- x1
 - x2
 - 5,8mm
15/64" x2
 - x2
 - 1:1

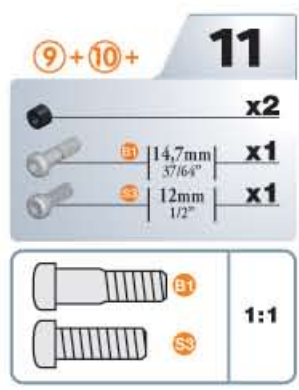

- 9+10+ 11**
- x2
 - 14,7mm
37/64" x1
 - 12mm
1/2" x1
 - 1:1
 - 1:1



12

	x2
	x1
	x1
	x2
	x2
	1:1

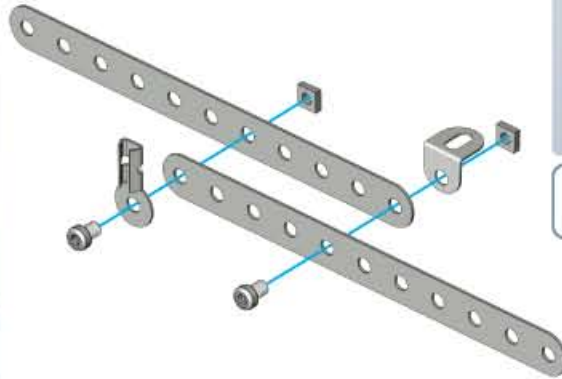

13

	x1
	x1
	x1
	1:1

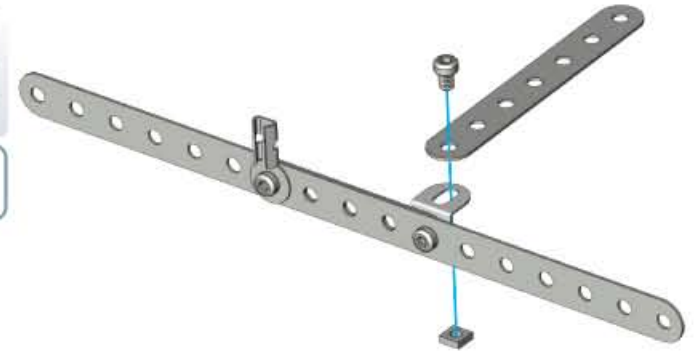

14

	x2
	x1
	x1
	x2
	x2
	1:1

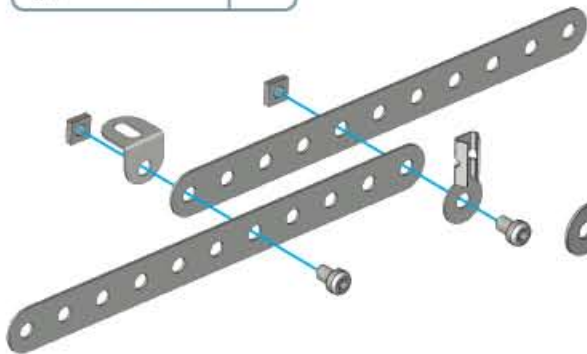

15

13 + 14 +

	x1
	x1
	1:1

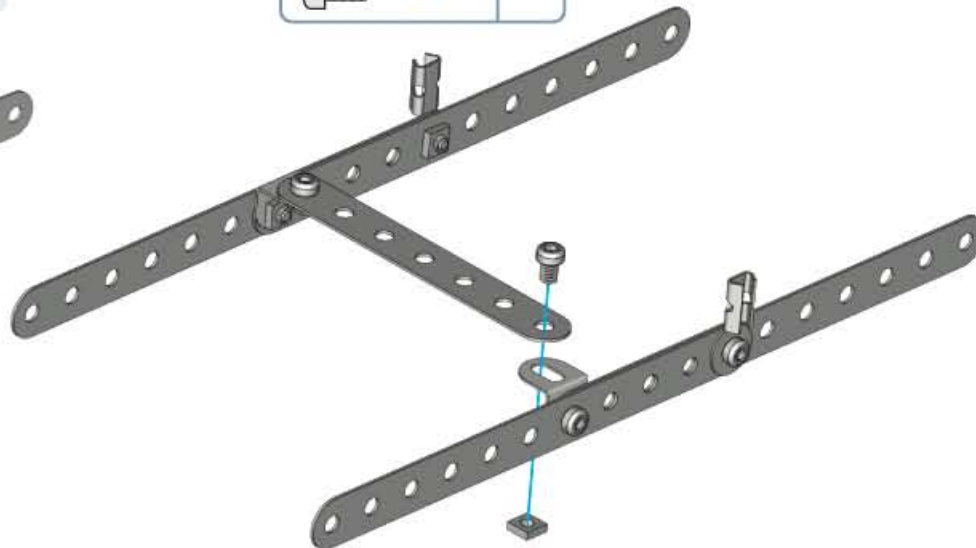

16

	x1
	x1
	x1
	x1
	x1
	1:1

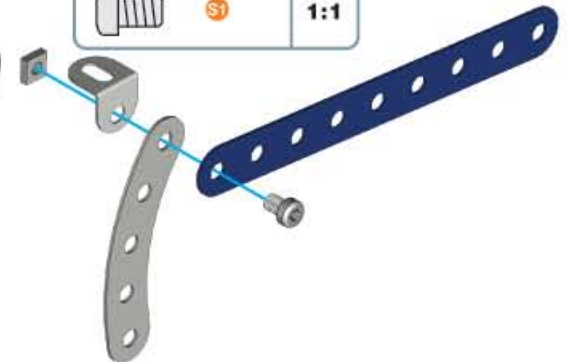

11 + 16 + 17

	5,8mm 15/64"	x1
		x1

	S1	1:1
---	-----------	------------

18

		x1
		x1
	5,8mm 15/64"	x2
		x2

	S1	1:1
---	-----------	------------

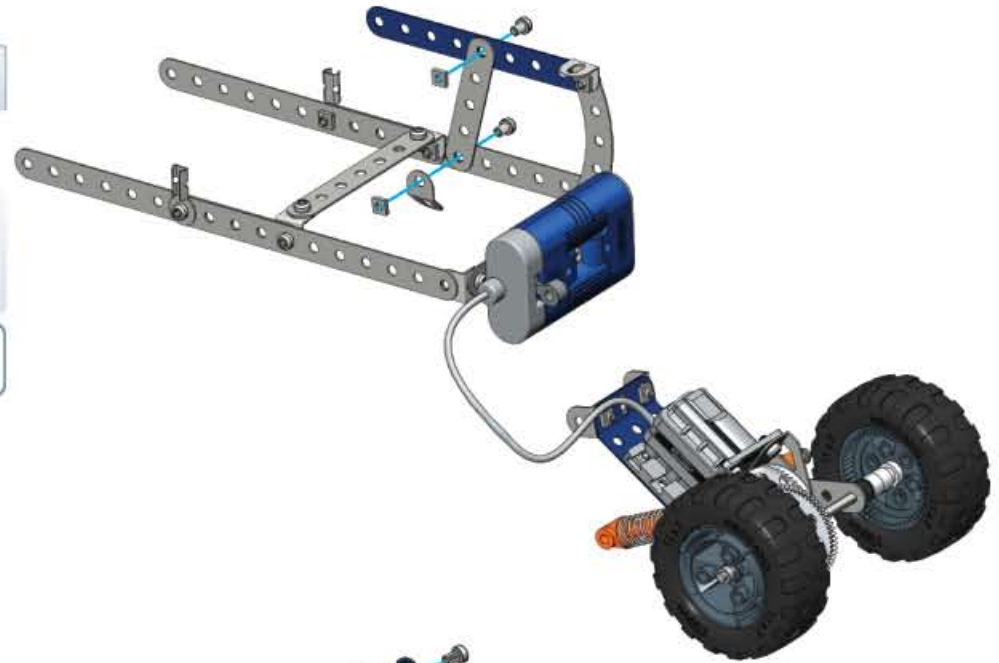
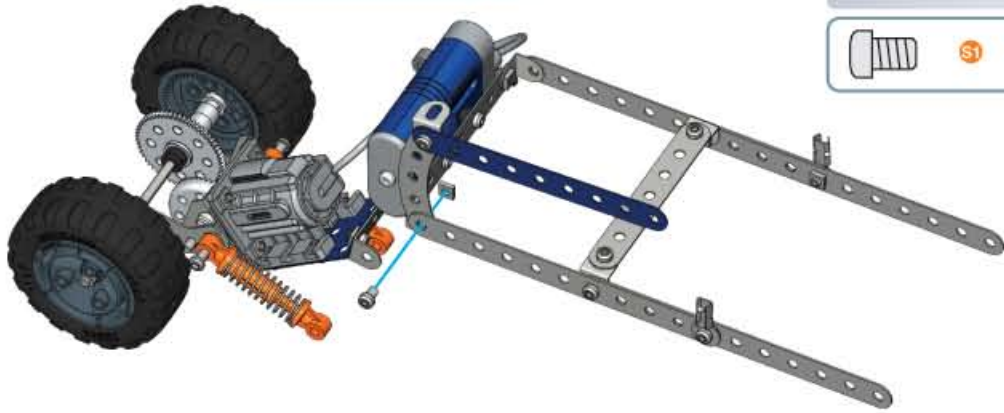

19

		x1
		x1
	5,8mm 15/64"	x1

	S1	1:1
---	-----------	------------









18 + 19 + 20

		x1
	5,8mm 15/64"	x2
		x2

	S1	1:1
---	-----------	------------



21

-  x1
-  x1
-  x1
-  x1
-  x1
-  x1

	S1	1:1
--	-----------	------------

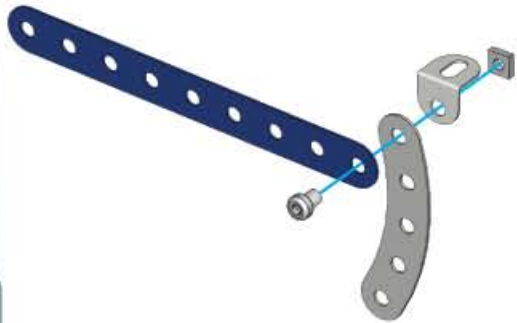

20+21+ **22**

-  **S1** | 5,8mm | 15/64" | **x1**
-  | **x1**

	S1	1:1
--	-----------	------------

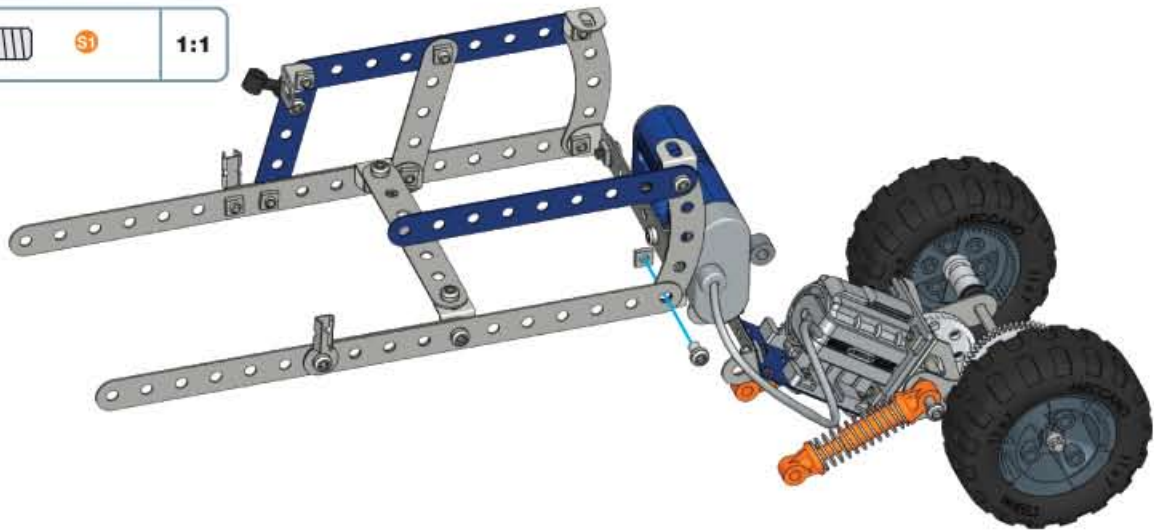

23

-  x2
-  x1
-  **S1** | 5,8mm | 15/64" | x3
-  x3

	S1	1:1
--	-----------	------------

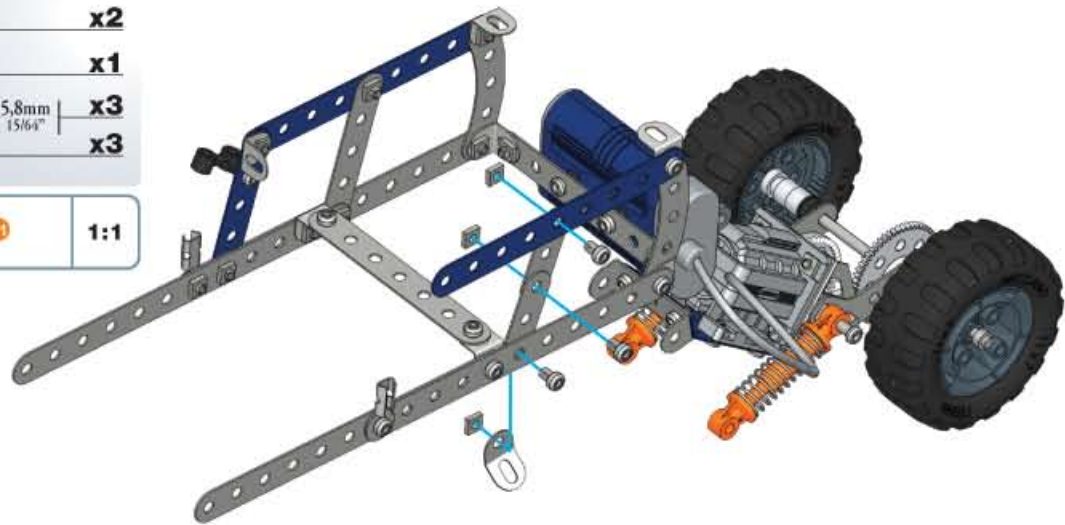

24

-  x1
-  x1
-  **S1** | 5,8mm | 15/64" | x1

	S1	1:1
---	-----------	------------

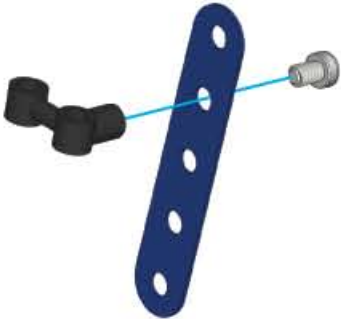

25

23 + 24 +

- x1
- 5,8mm | 15/64" x2
- x2
- 1:1

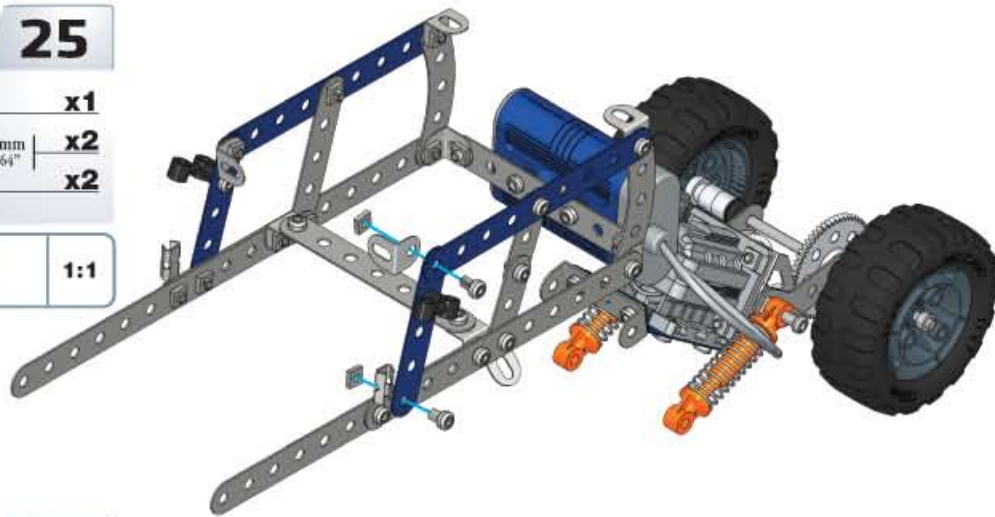

26

- x2
- x2
- 5,8mm | 15/64" x2
- x2
- 1:1



27

- x4
- x1
- 38,1mm | 1 1/2" x1
- x1
- 1:1

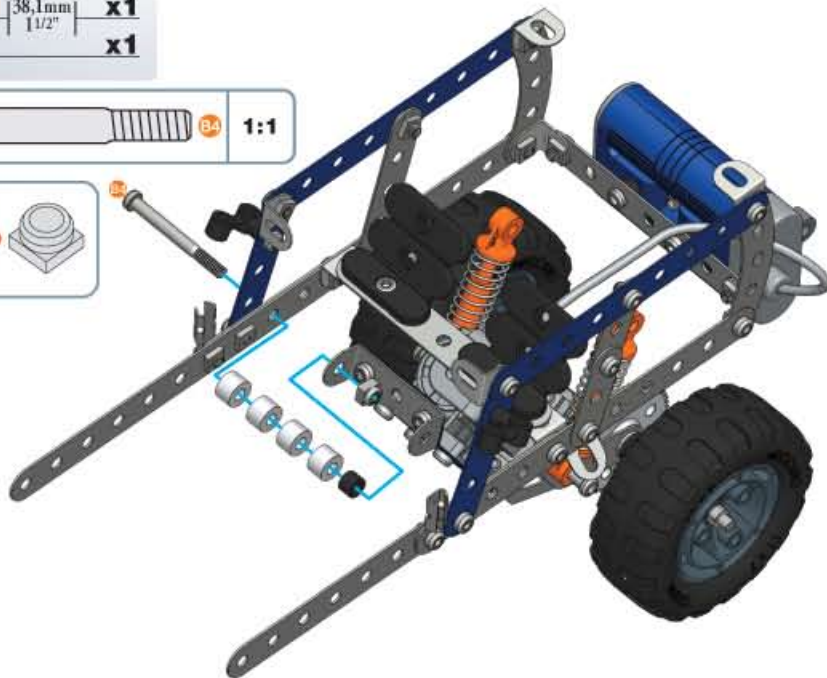

4

+ 4

28

- x4
- x1
- 38,1mm | 1 1/2" x1
- x1
- 1:1



4

+ 4

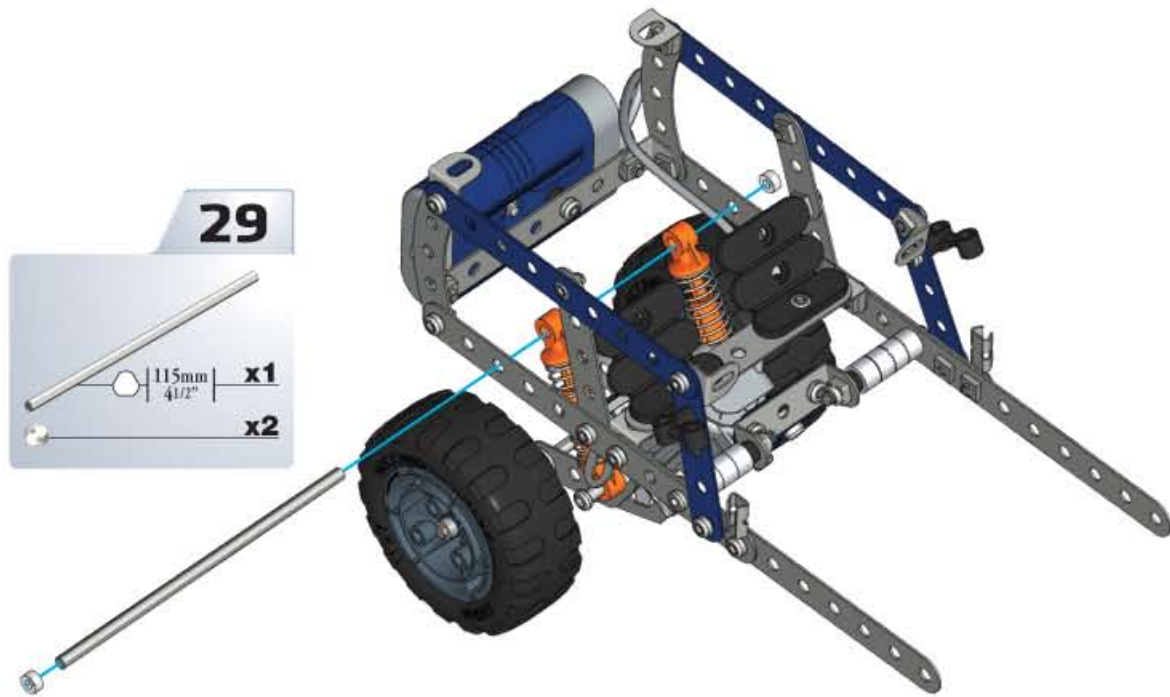

29

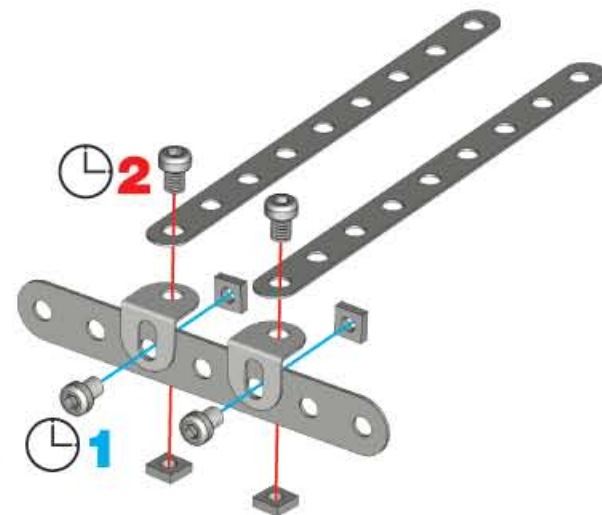

31

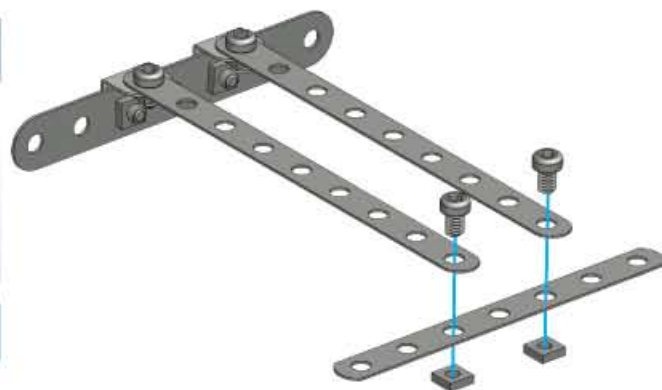

32



33

-  x2
-  12mm | x2
-  1/2" | x2
-   1:1

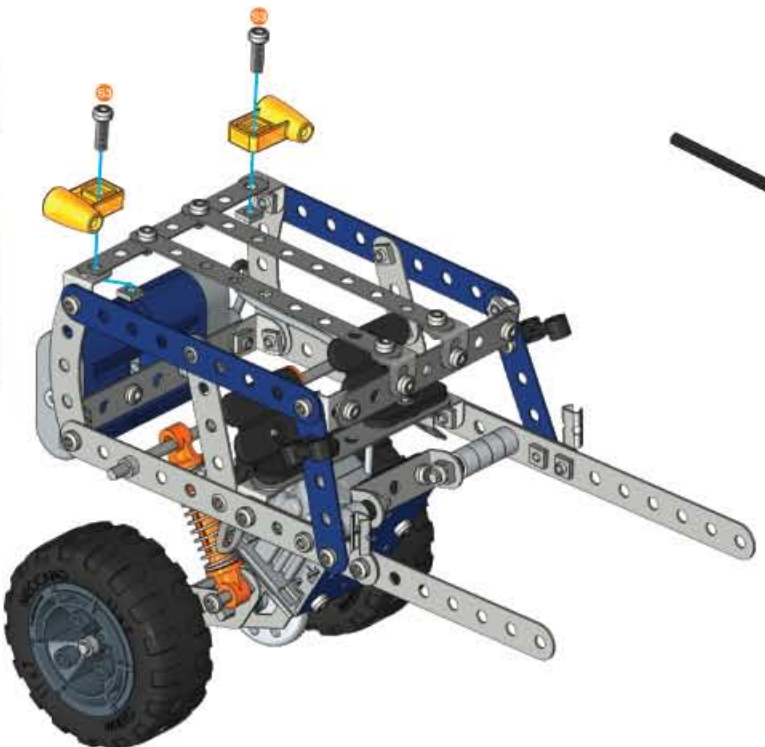

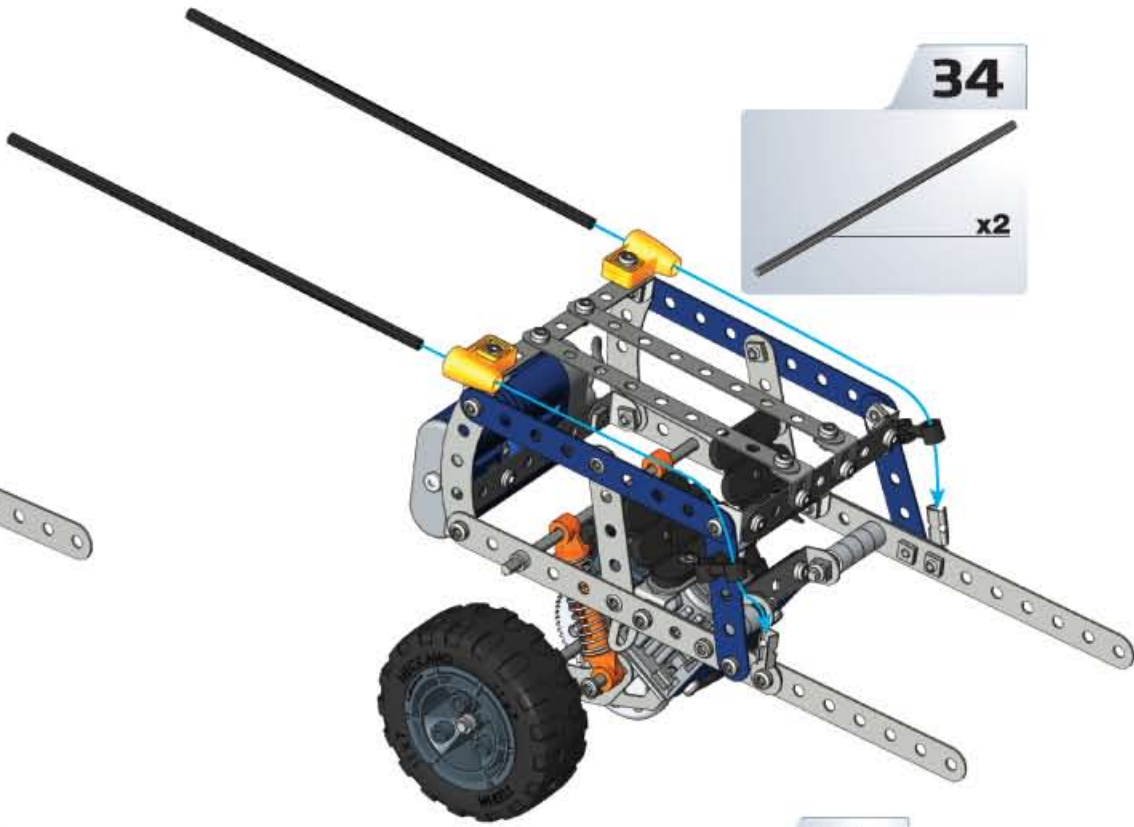

34

-  x2



35

-  100mm | x2
-  315/16" | x4



-  100mm | x2
-  315/16" | x4
-   1:1

36

-  x2
-  100mm | x1
-  315/16" | x1
-   5,8mm | x4
-  15/64" | x4

-   1:1

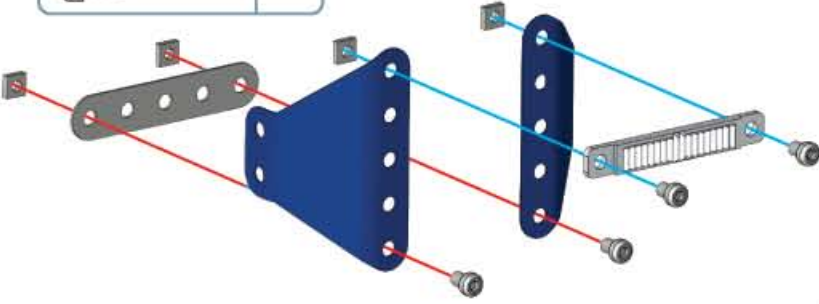

37

	x1
	x1
	x1
	x1

	1:1
--	-----



36 + 37 + 38

	x1
	x1

	1:1
--	-----

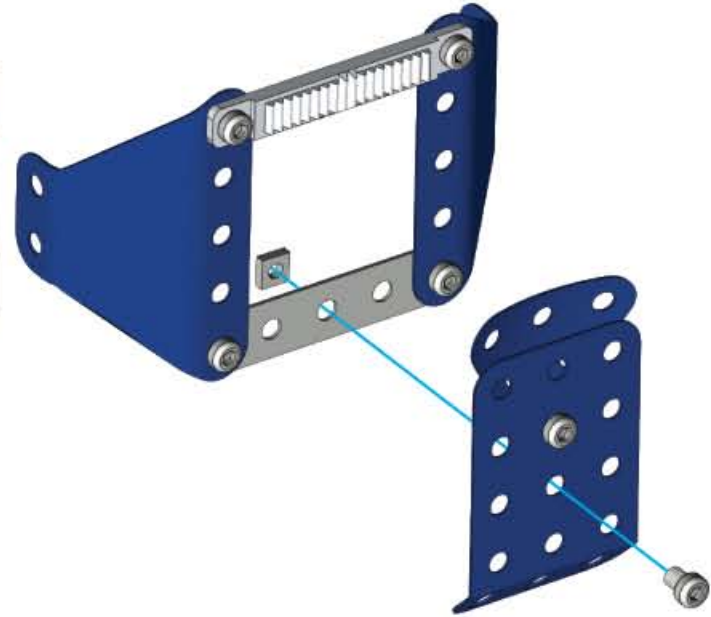

39

	x1
	x2
	x2
	x2
	x2
	x4

	1:1
	1:1

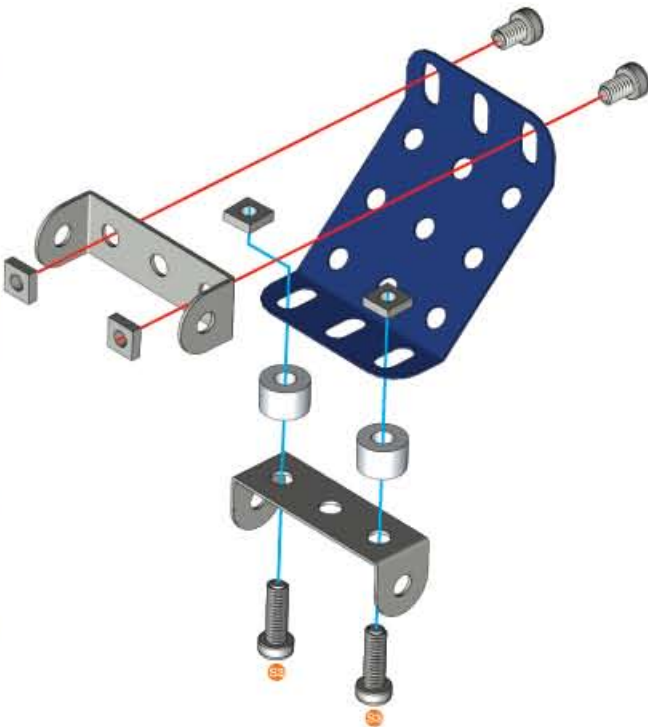

40

	x1
	x2
	x2

	1:1
--	-----

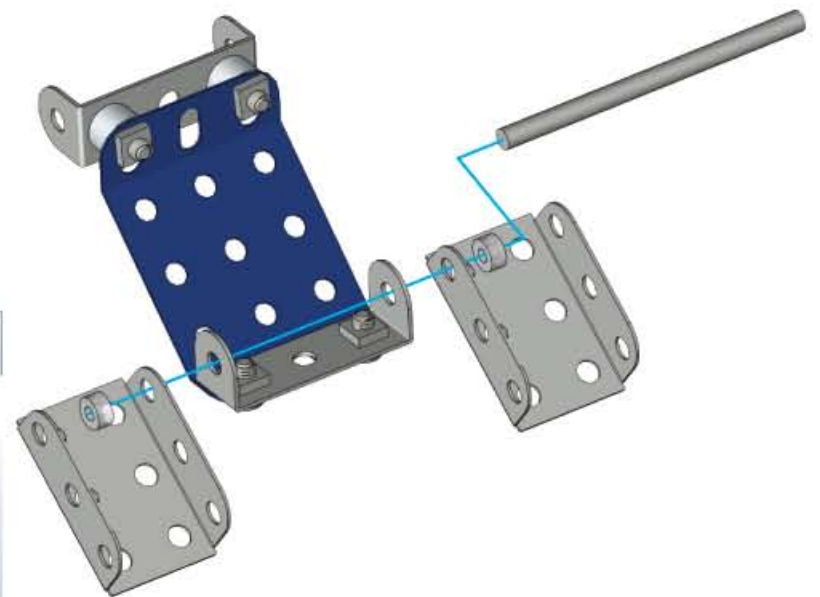

41

	x1
	x4
	x4
	1:1

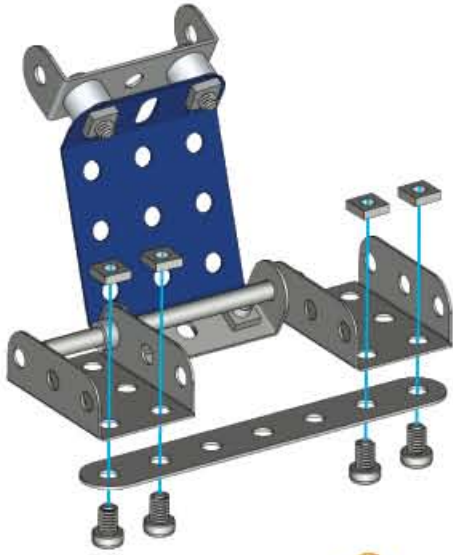
**42**

	x1
	x2
	x2
	1:1

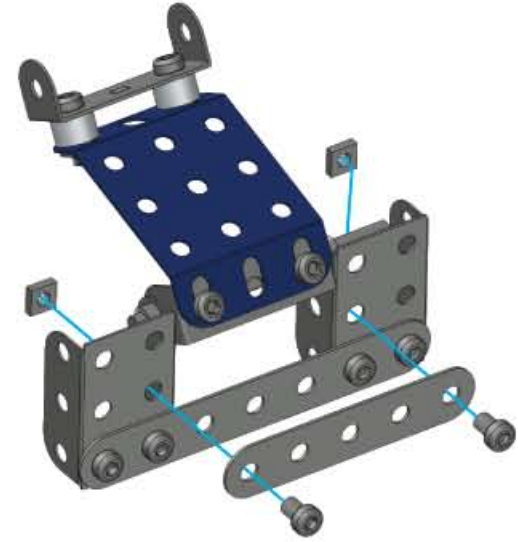
**43**

35 + 42 +	x2
	x2
	x2
	1:1

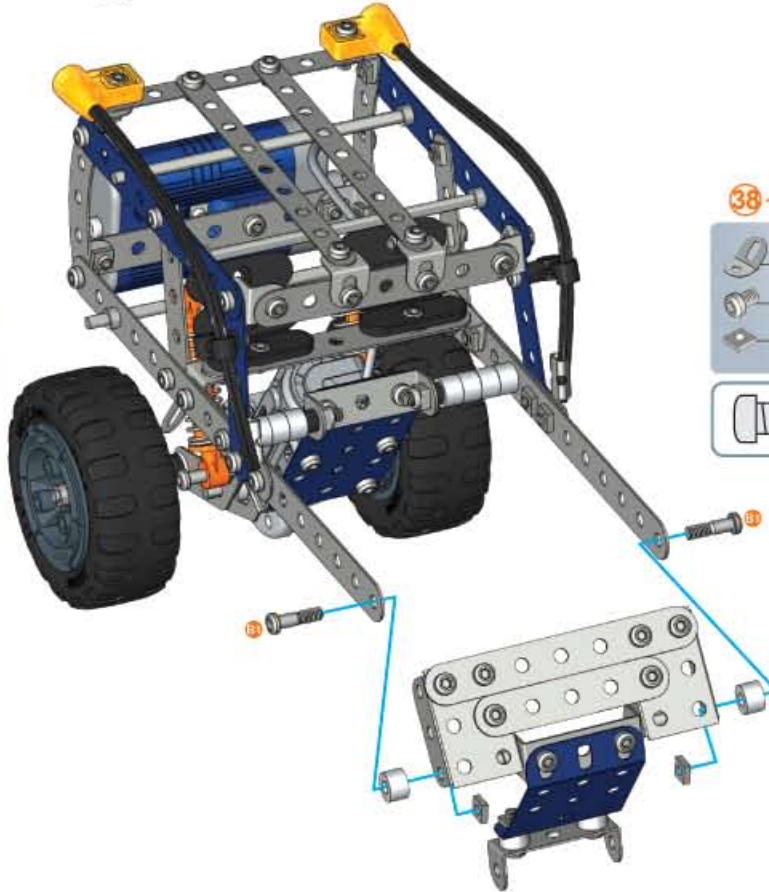

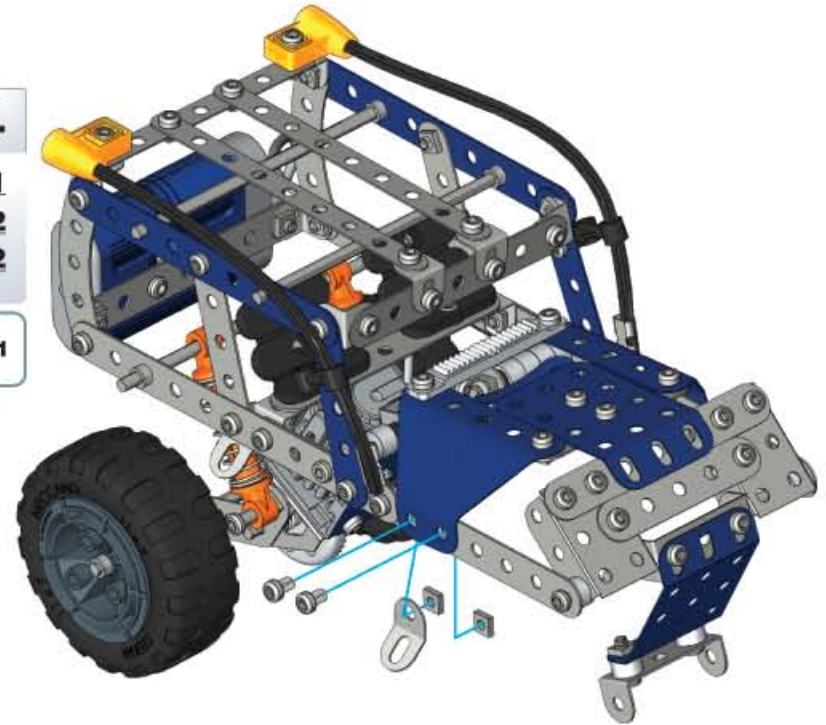

**44**

38 + 43 +	x1
	x2
	x2
	1:1









45

-  **x1**
-  **x1**
-  **x1**
-  **x1**
-  **x2**

-  **B1** **1:1**
-  **S1**



47

-  **x1**
-  **x1**
-  **x1**
-  **x1**
-  **x2**

-  **B1** **1:1**
-  **S1**

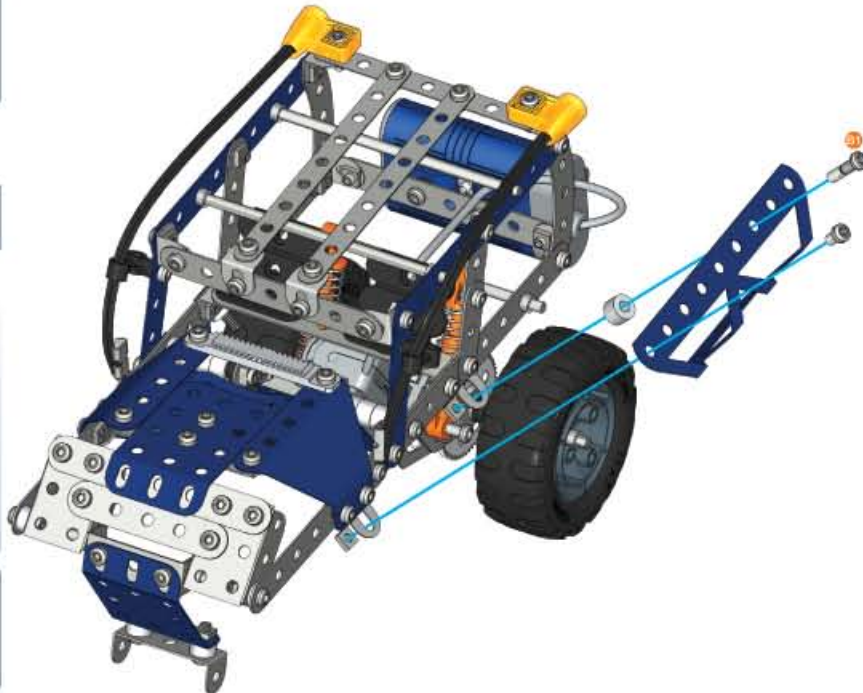

46

-  **x1**
-  **S1** **x2**
-  **x2**
-  **B1** **1:1**

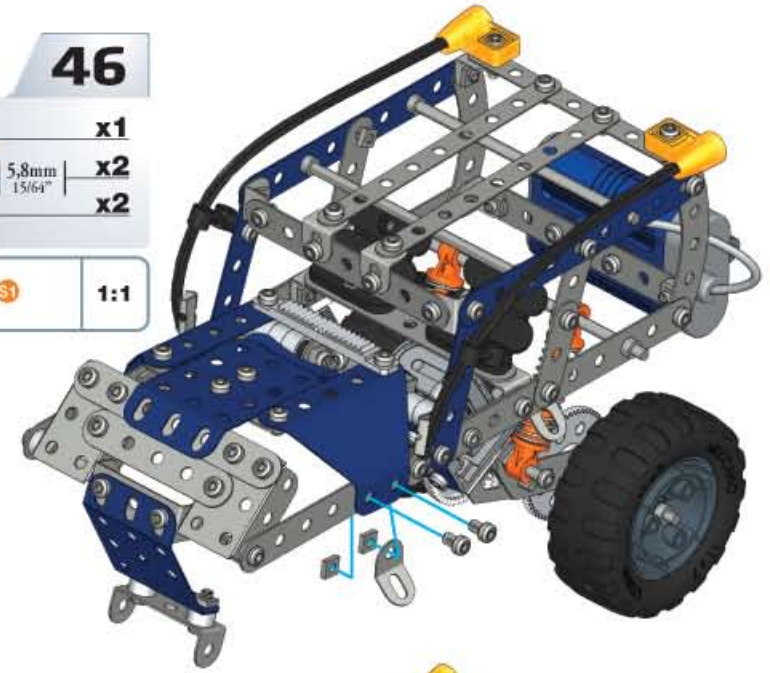

48

-  **S1** **x1**
-  **x1**
-  **B1** **1:1**



49

-  130mm | 5 1/8" | **x1**
-  **x2**
-  **x2**
-  **x2**
-  **x6**
-  **x4**

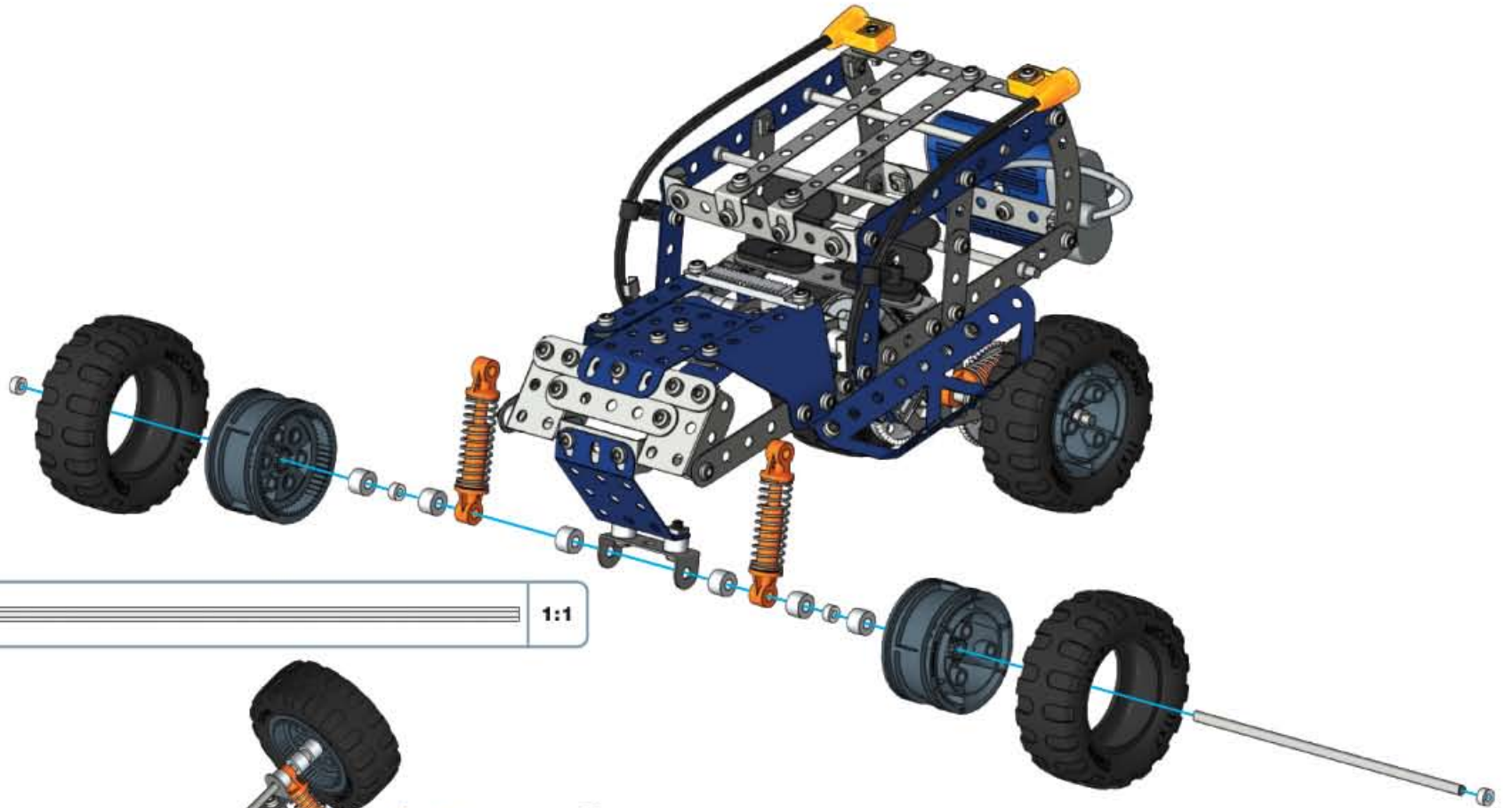

1:1

50

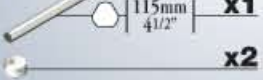
-  115mm | 4 1/2" | **x1**
-  **x2**

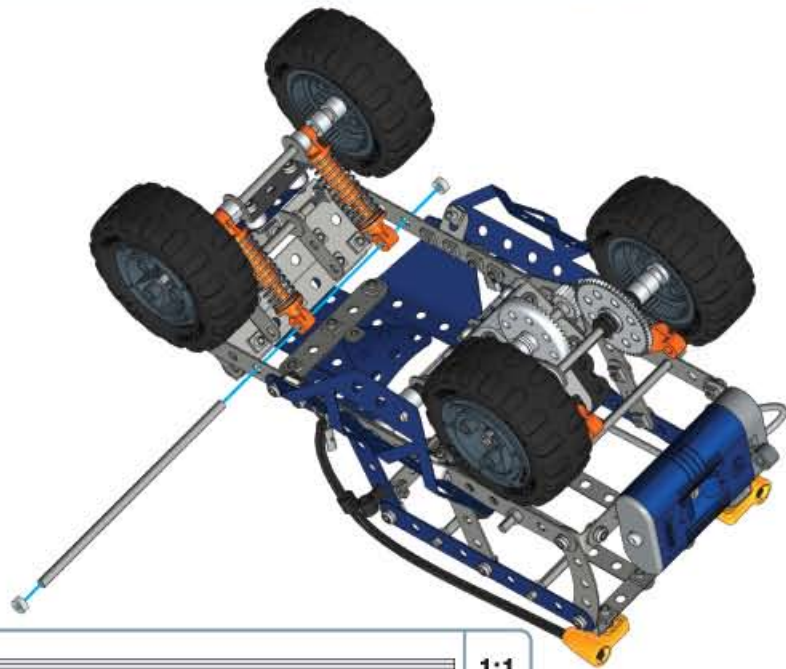

1:1





1

-  **x1**
-  **x2**
-  **5,8mm** **x4**
-  **15/64"** **x4**

-  **S1** **1:1**
-  Scale 1 Escala 1 Mittakaava 1
-  Echelle 1 Schaal 1 Målestok 1
-  Maßstab 1 Escala 1 Күлмеке 1
-  Scala 1 Skala 1 масштаб 1

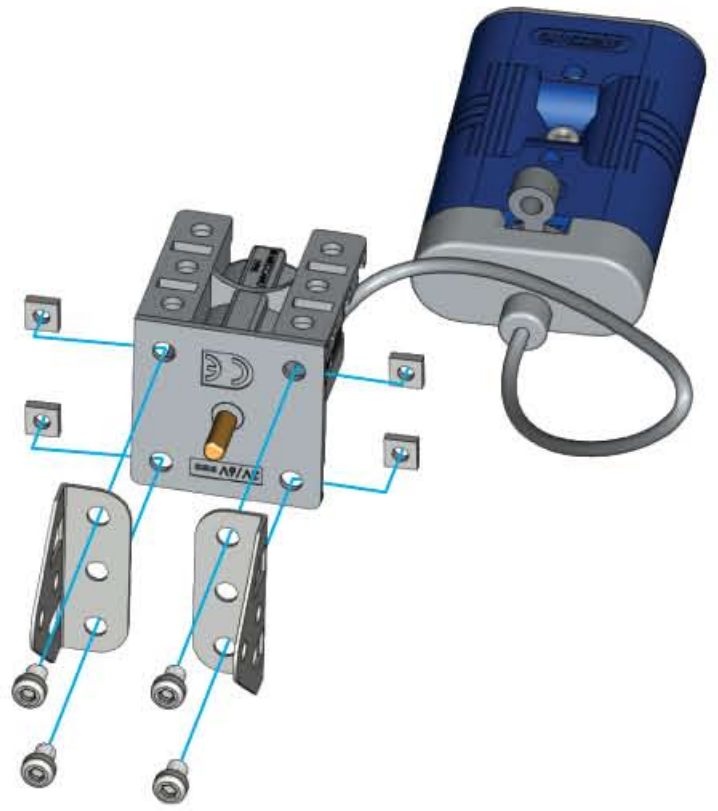

2

-  **x1**
-  **x1**

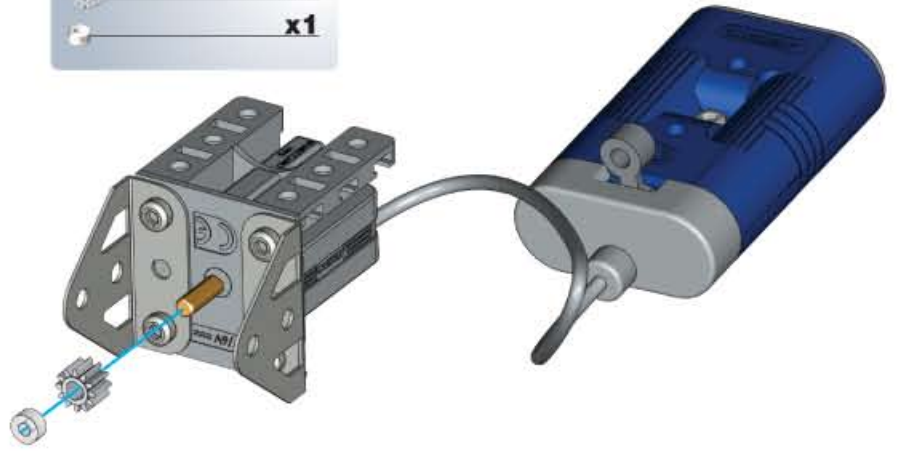

3

-  **x2**
-  **5,8mm** **x2**
-  **15/64"** **x2**

-  **S1** **1:1**

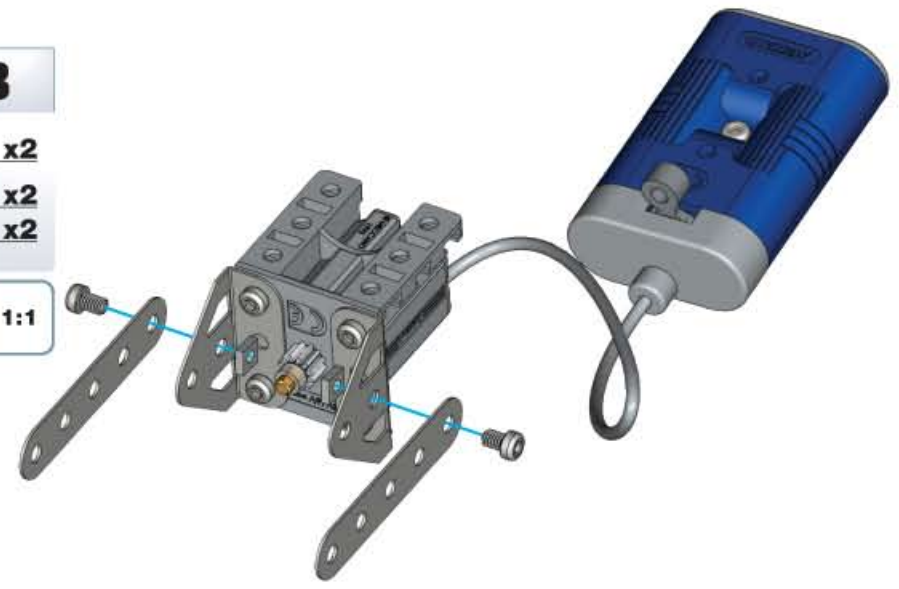

4

-  50mm | 2" | **x1**
-  **x1**
-  **x1**
-  **x1**
-  **x2**
-  **x1**

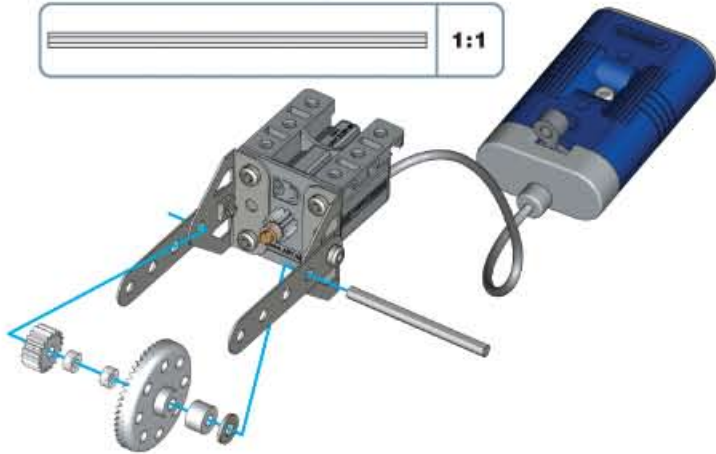



5

-  130mm | 5 1/8" | **x1**
-  **x2**
-  **x2**
-  **x6**
-  **x1**
-  **x2**
-  **x2**



6

-  **x2**
-  **x1**
-  **x1**
-  5.8mm | 15/64" | **x4**
-  5.8mm | 15/64" | **x4**

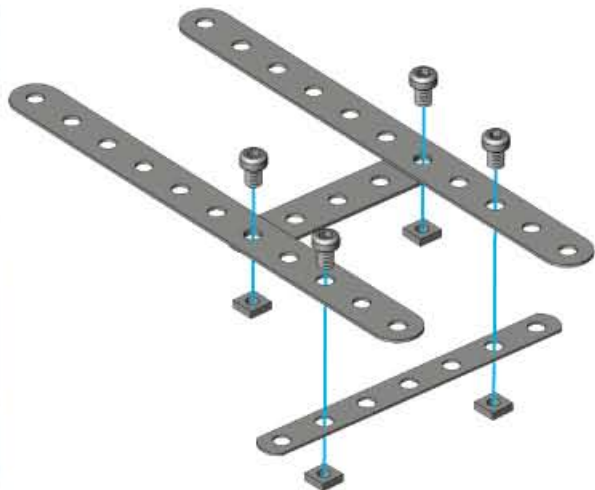

7

-  **x1**
-  5.8mm | 15/64" | **x2**
-  5.8mm | 15/64" | **x2**

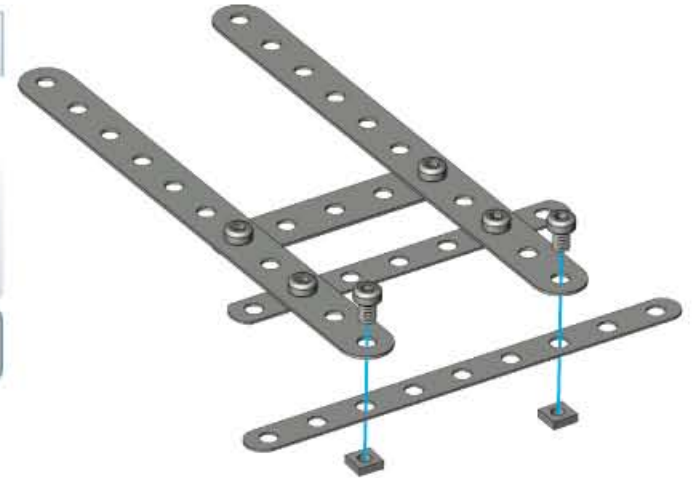

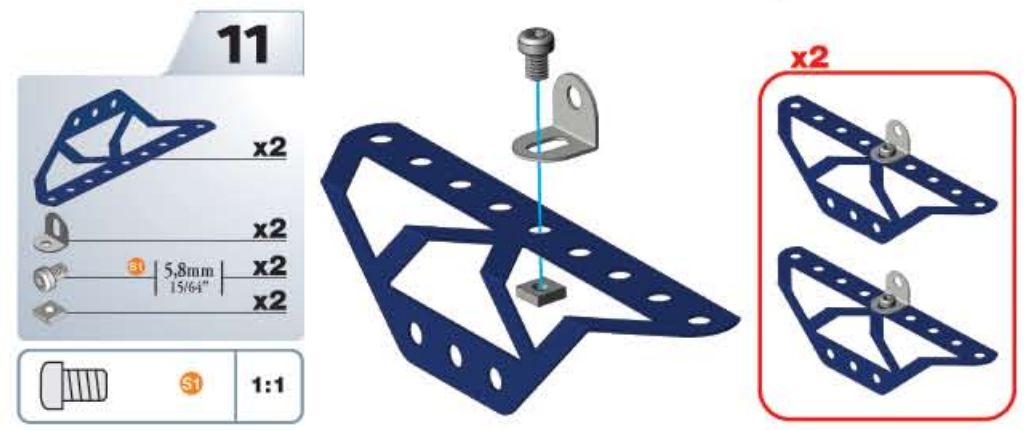
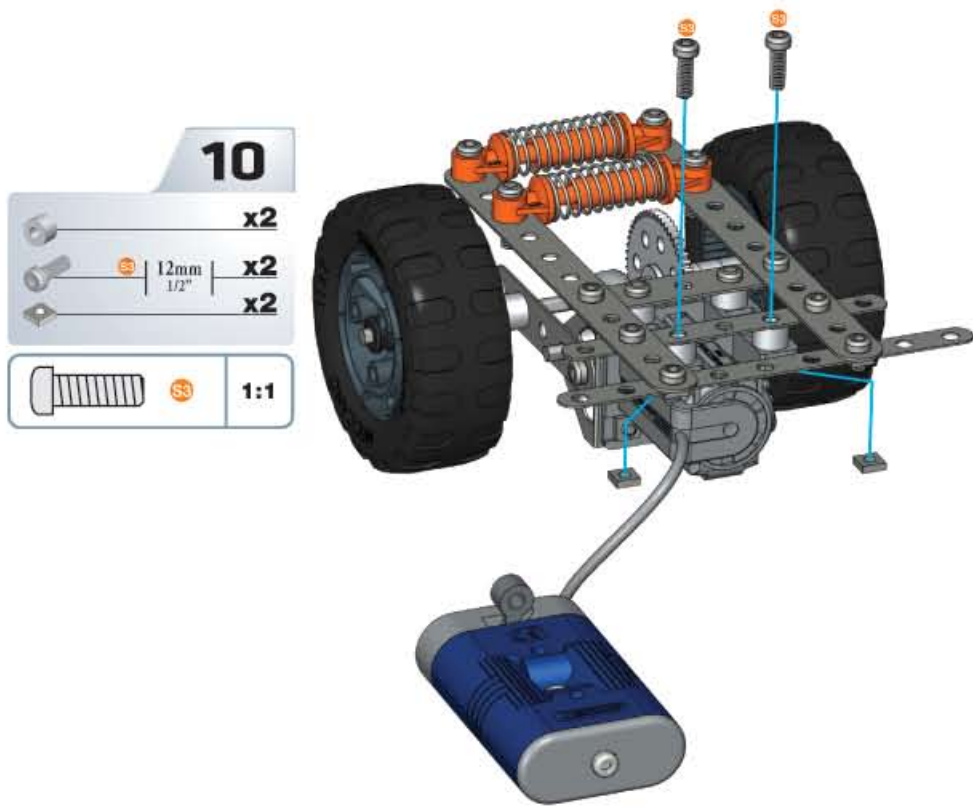
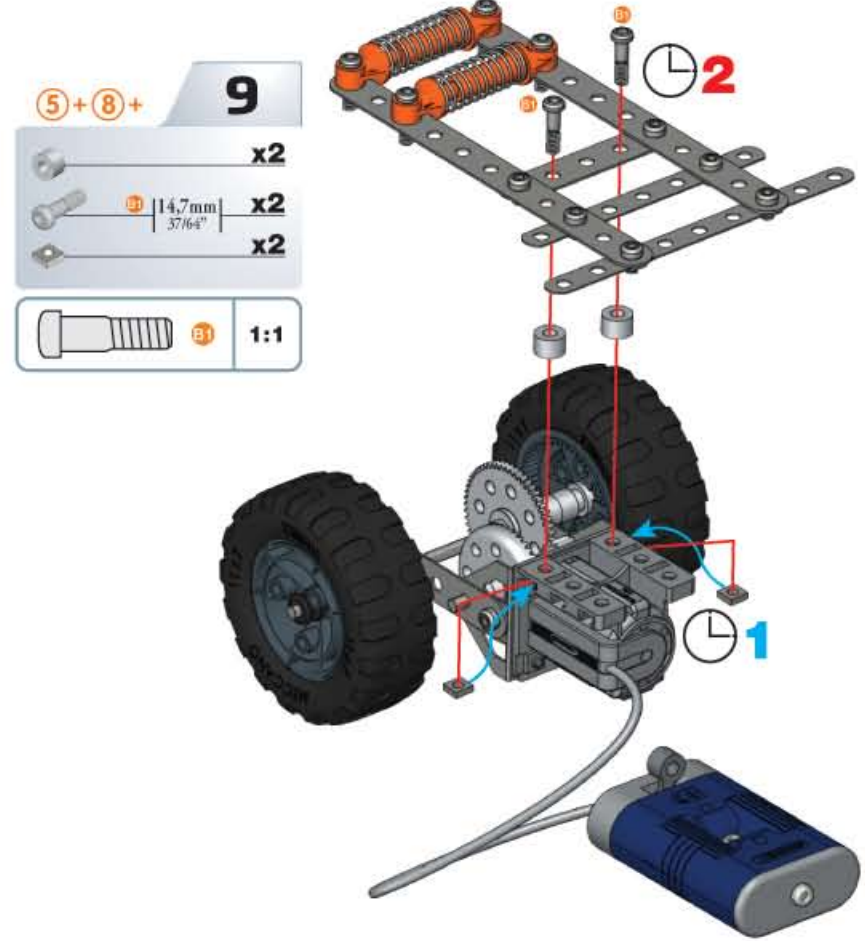
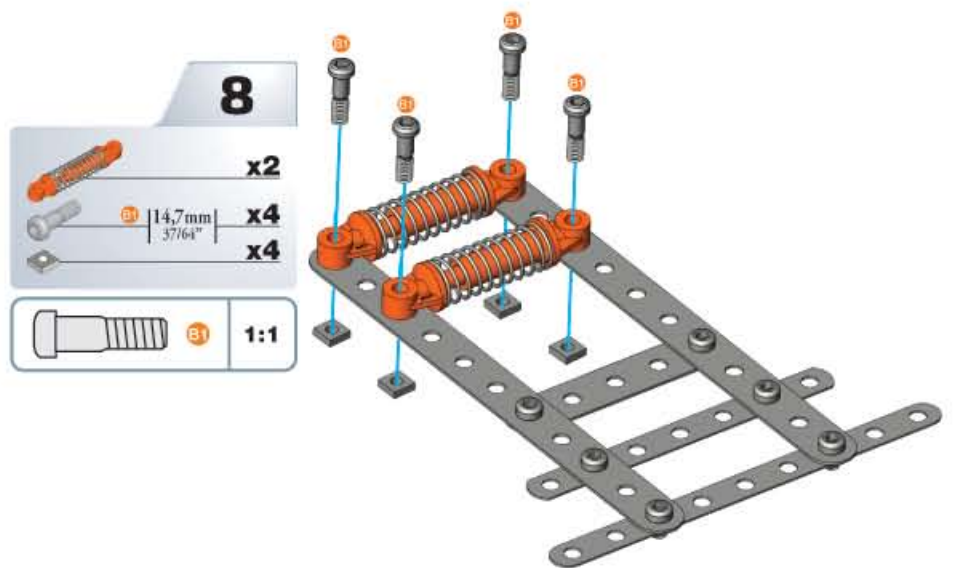

10 + 11 + **12**

 **5,8mm** | **x2**
15/64"

 **1:1**

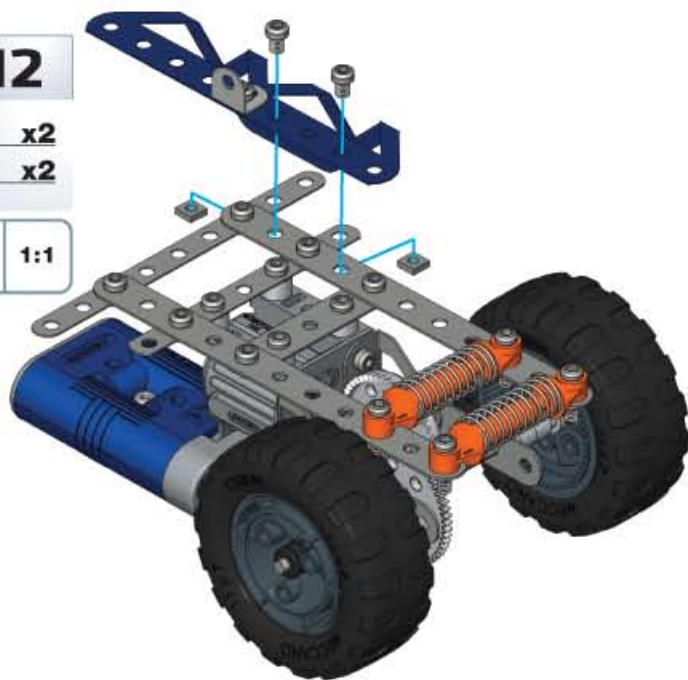

10 + 12 + **13**

 **5,8mm** | **x2**
15/64"

 **1:1**

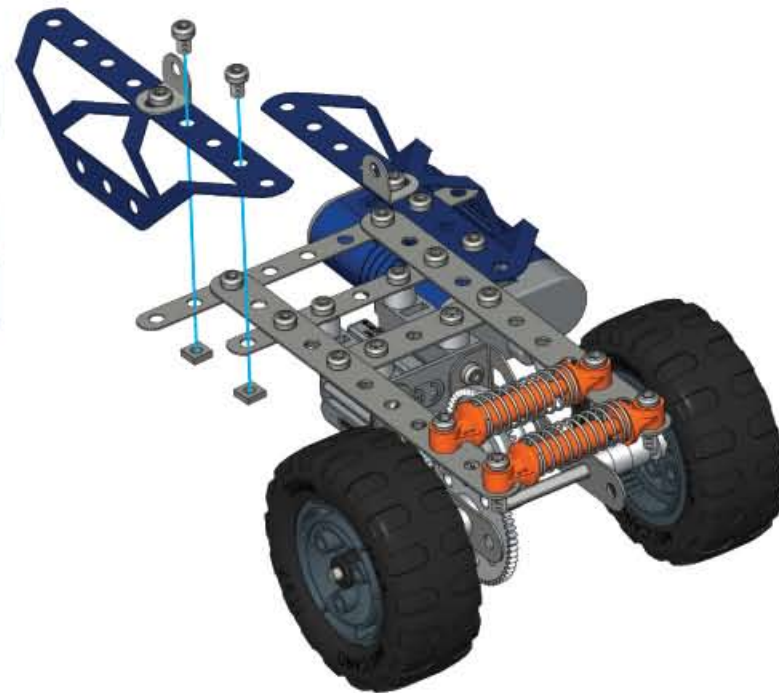

14

 **x1**

 **x2**

 **5,8mm** | **x2**
15/64"

 **x2**

 **1:1**

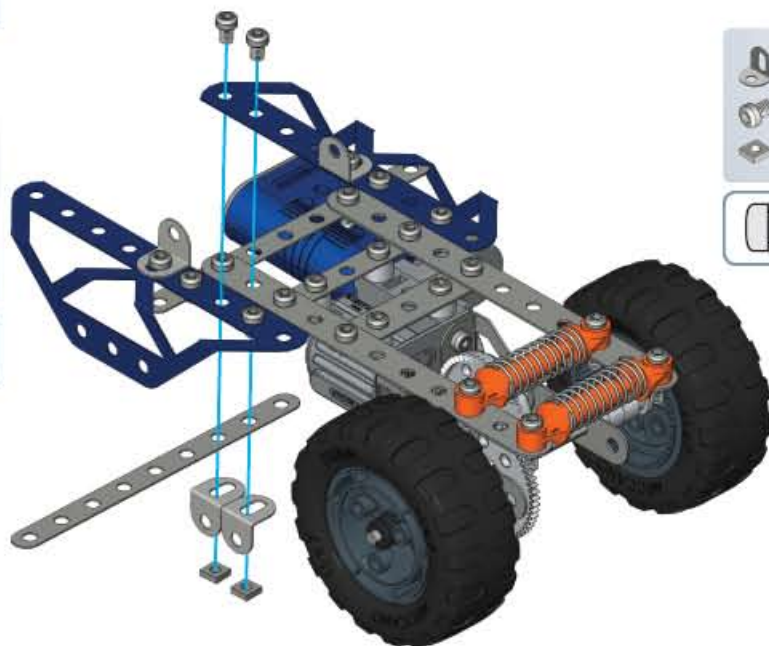

15

 **x2**

 **5,8mm** | **x2**
15/64"

 **x2**

 **1:1**

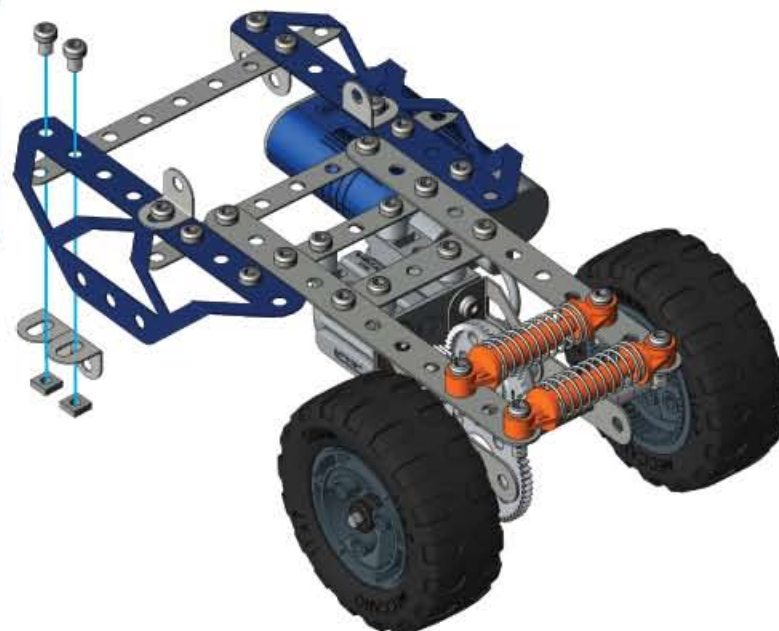

16

- 5,8mm | 15/64" x2
- S1 1:1

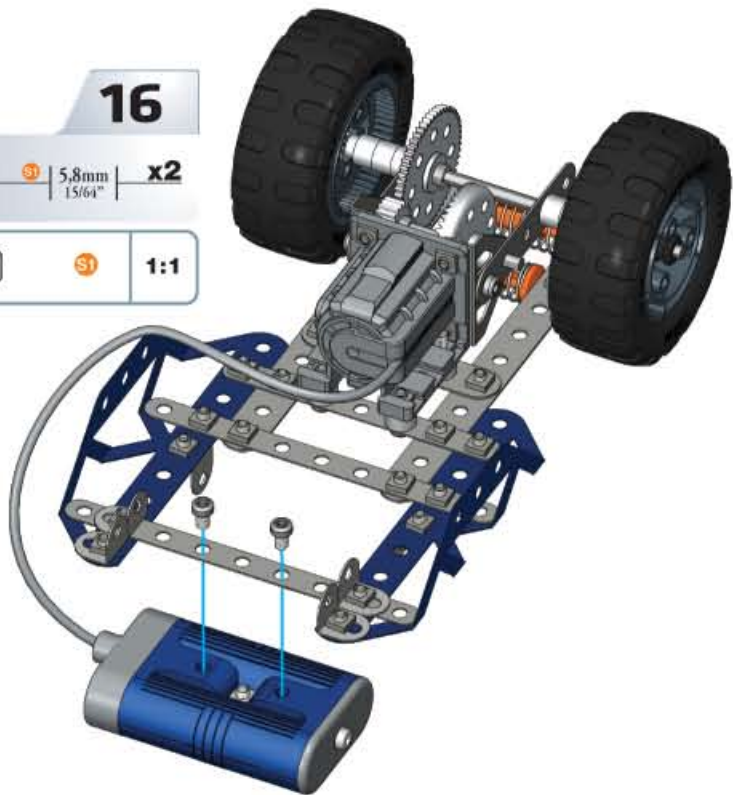

17

- x1
- x1
- 5,8mm | 15/64" x2
- x2
- S1 1:1

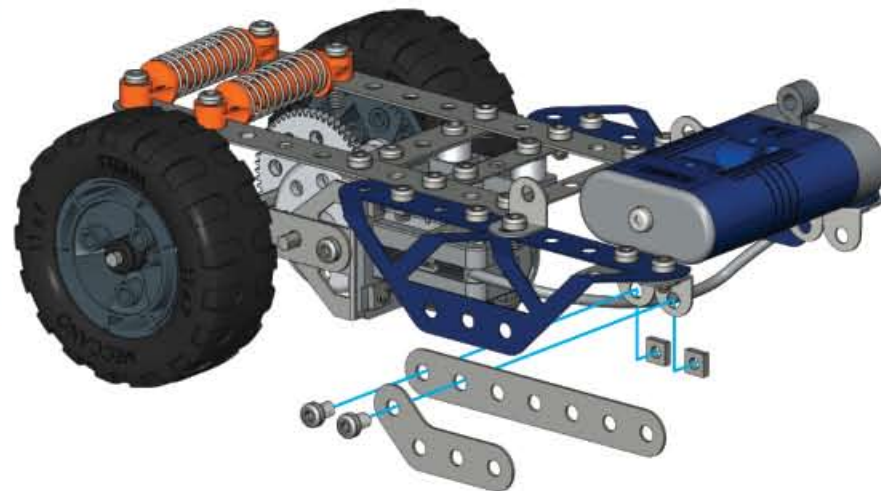

18

- x1
- x1
- 5,8mm | 15/64" x2
- x2
- S1 1:1

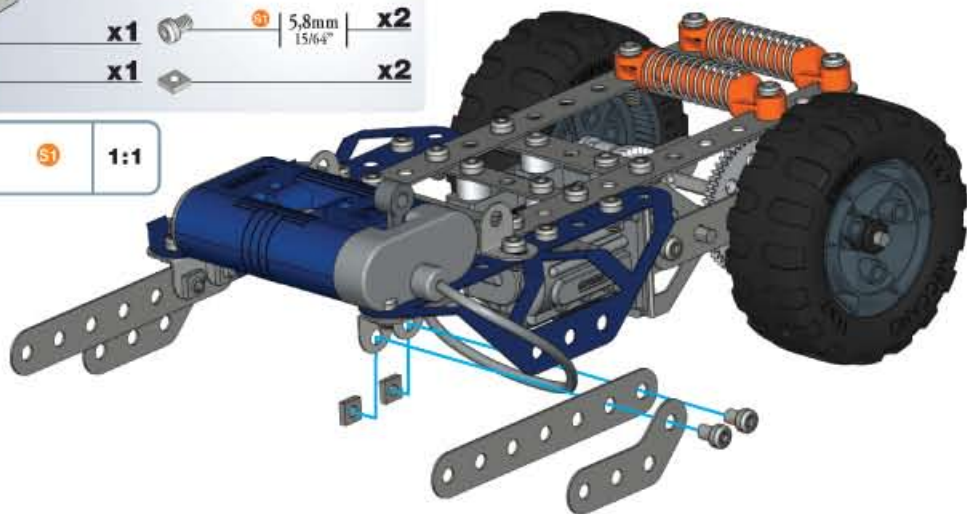

19

- x2
- 5,8mm | 15/64" x2
- x2
- S1 1:1

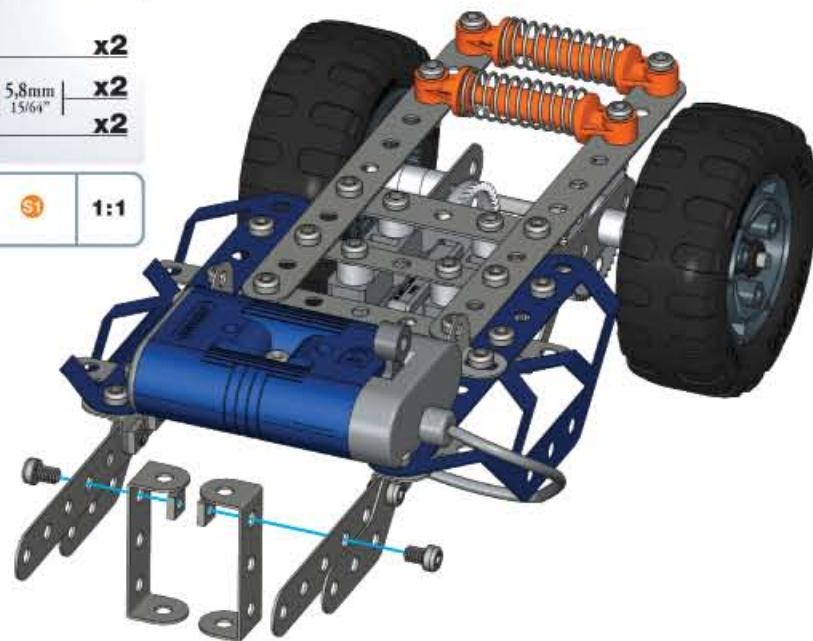



20

-  x2
-  x1
-  | 5,8mm | x2
-  x2

-  | S1 | 1:1

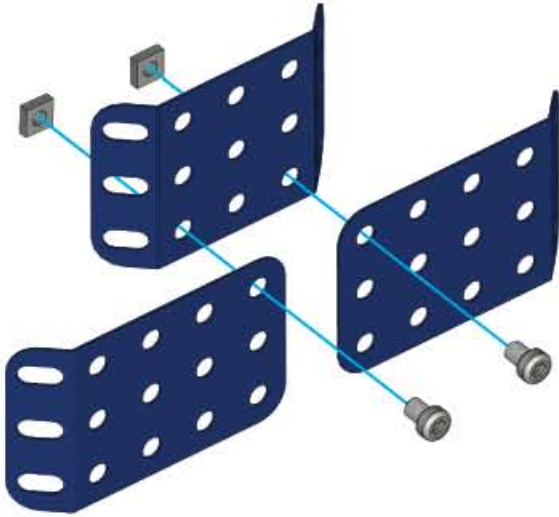

22

-  x1
-  x2
-  x2
-  x4
-  | 19mm | x2
-  | 3/4" | x2

-  | S2 | 1:1

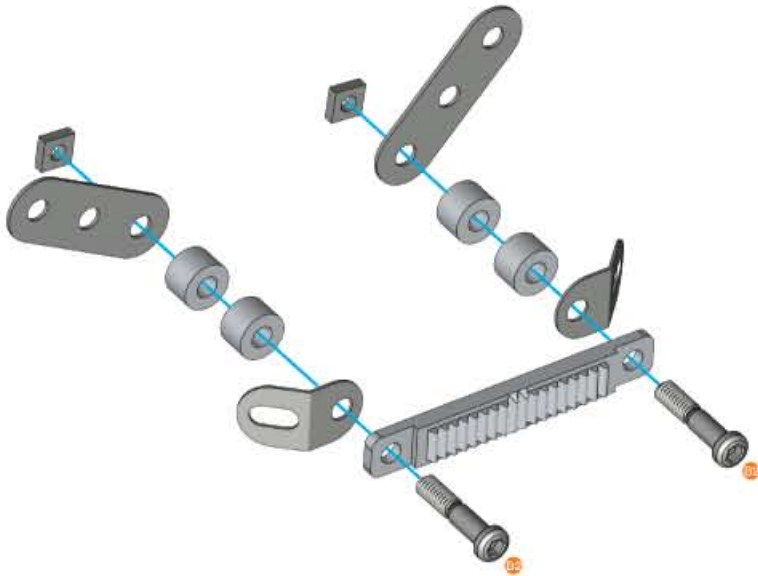

21

-  x1
-  | 5,8mm | x2
-  x2

-  | S1 | 1:1

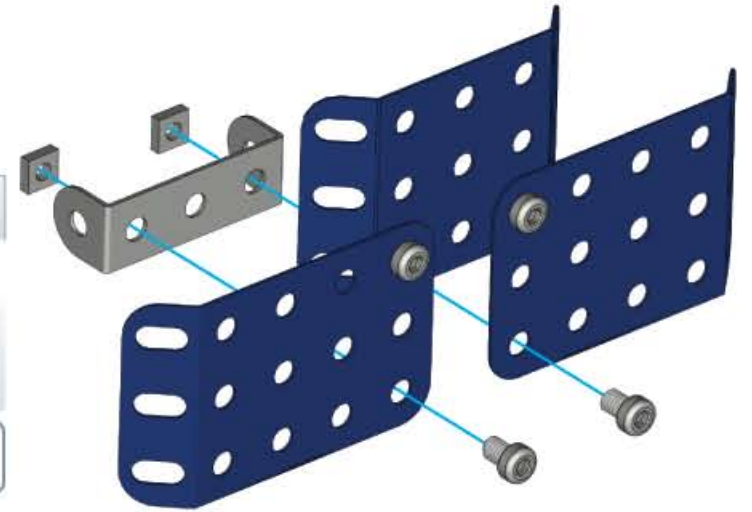

23

-  | 5,8mm | x2
-  x2

-  | S1 | 1:1

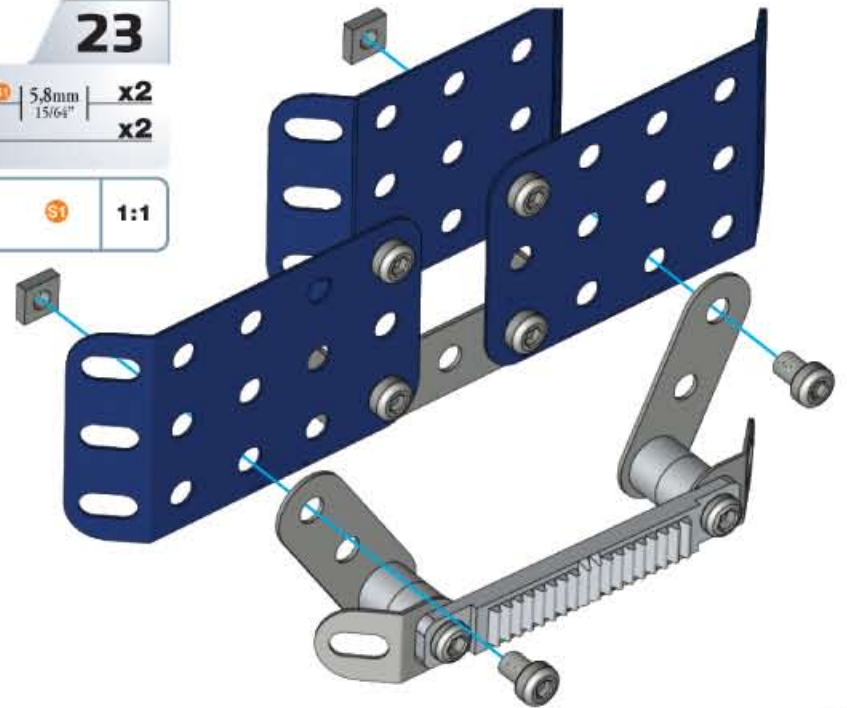

24

	x2
	x2
	x2
	1:1

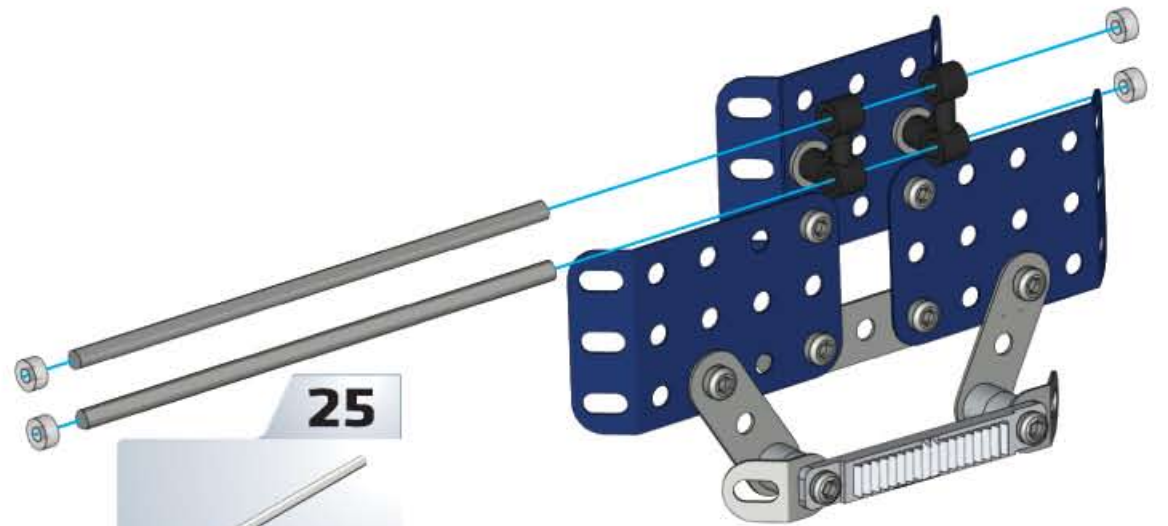
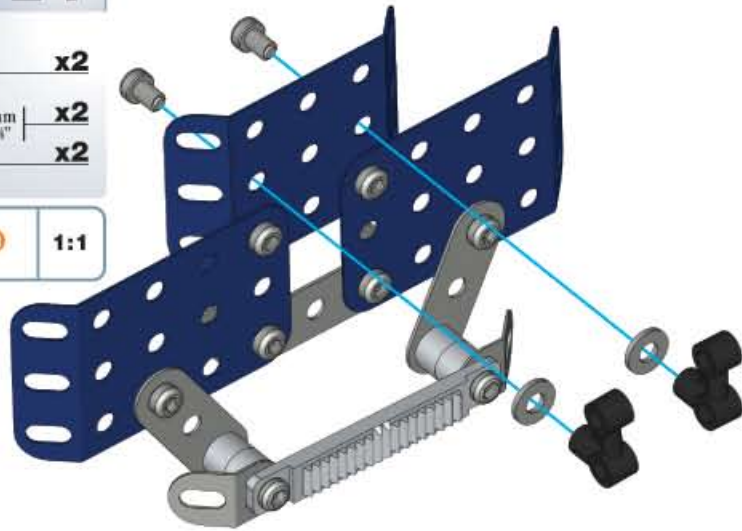

25

	x2
	x4
	1:1

26

	x1
	x1
	x1
	x2
	1:1

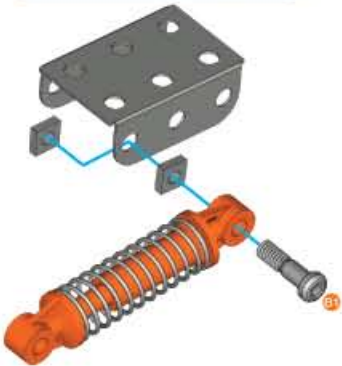

27

	x1
	x1
	x2
	x2
	1:1

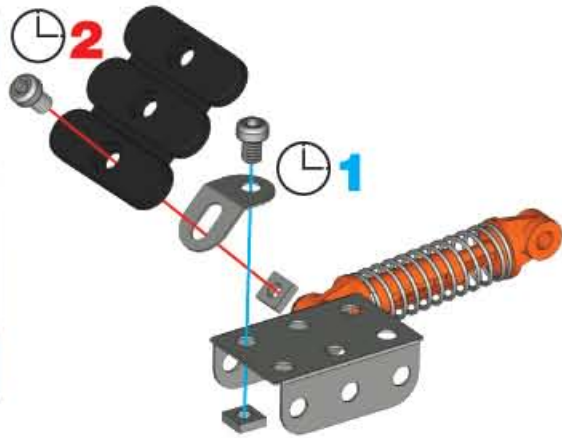

28

	x1
	x1
	x2
	x2
	1:1

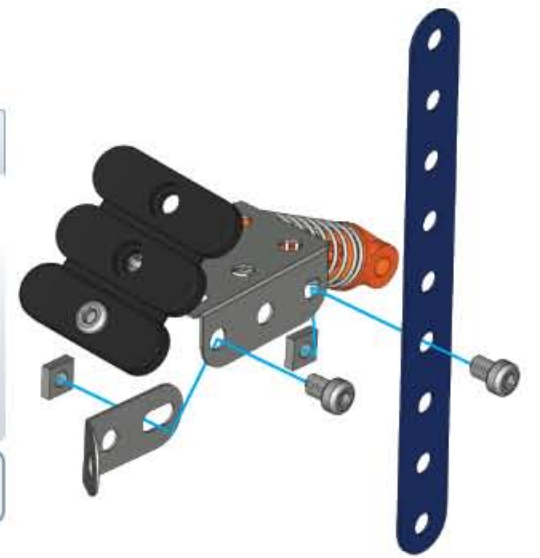

29

	x1
	x1
	x1
	1:1

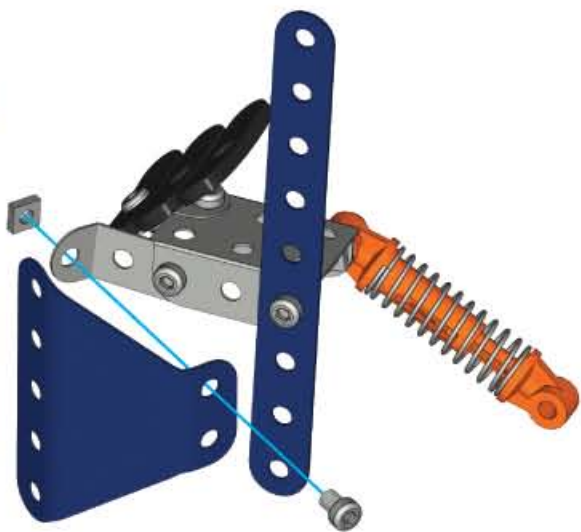

30

	x2
	x1
	x1
	1:1

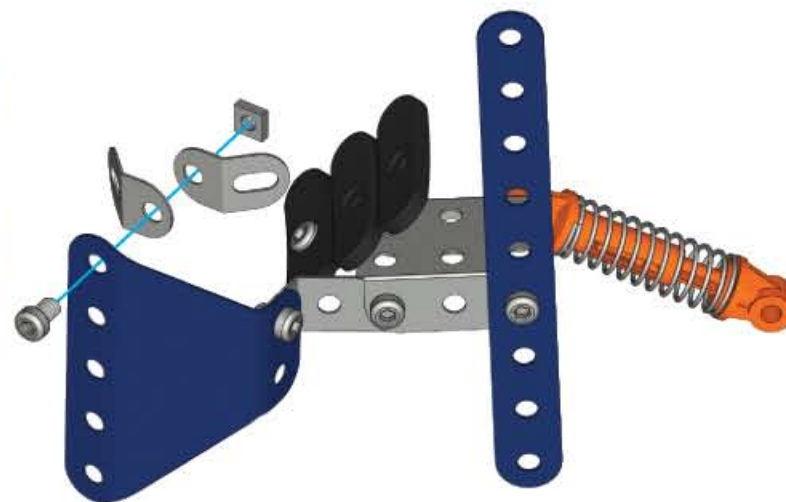

25+30+ **31**

	x1
	x2
	x2
	1:1

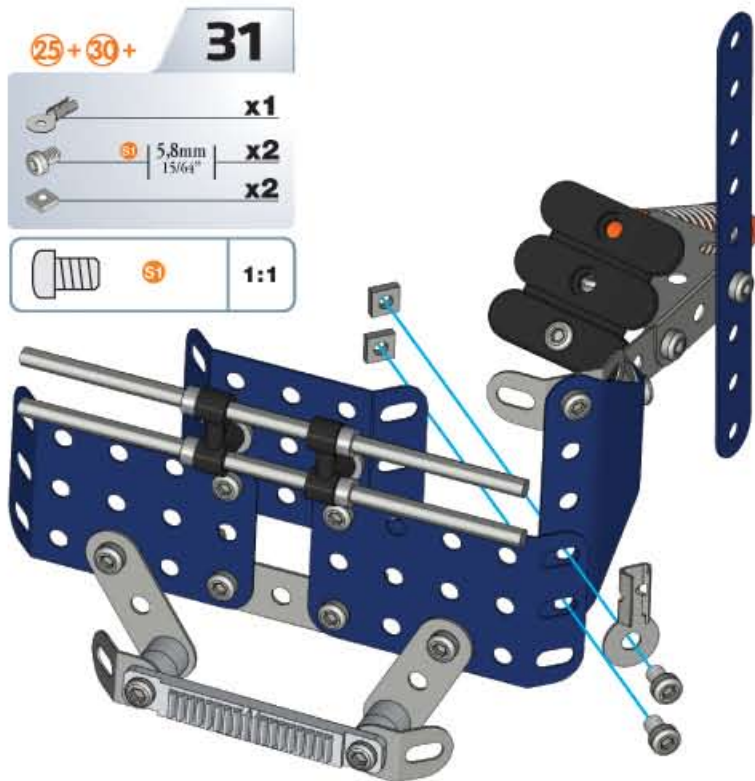

32

	x1
	x1
	x1
	x1
	1:1

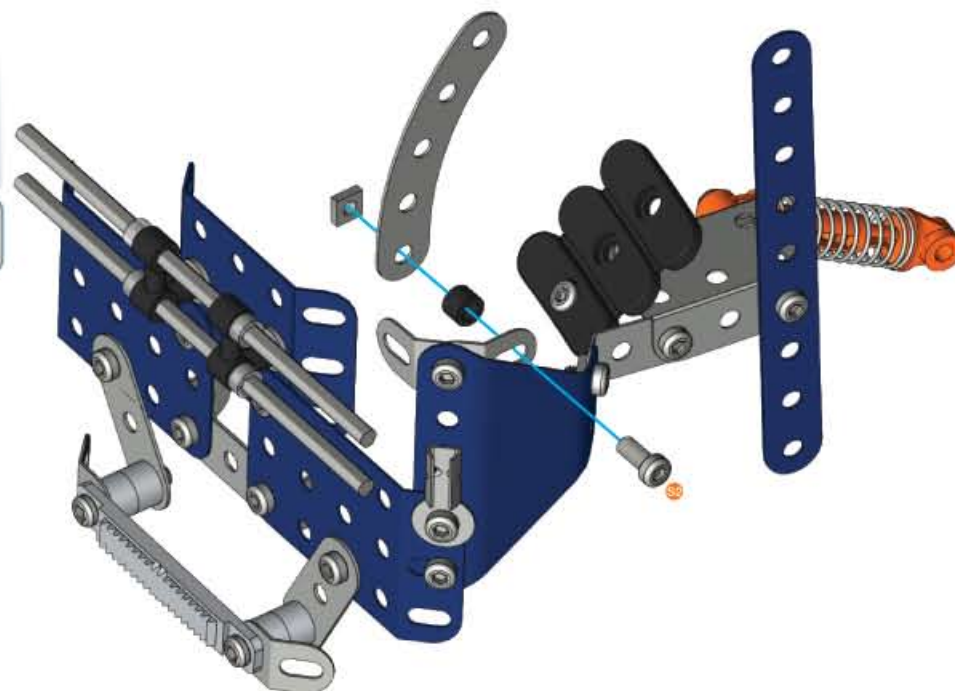

33

-  x1
-  x2
-  x3
-  x3

-  **S1** 1:1

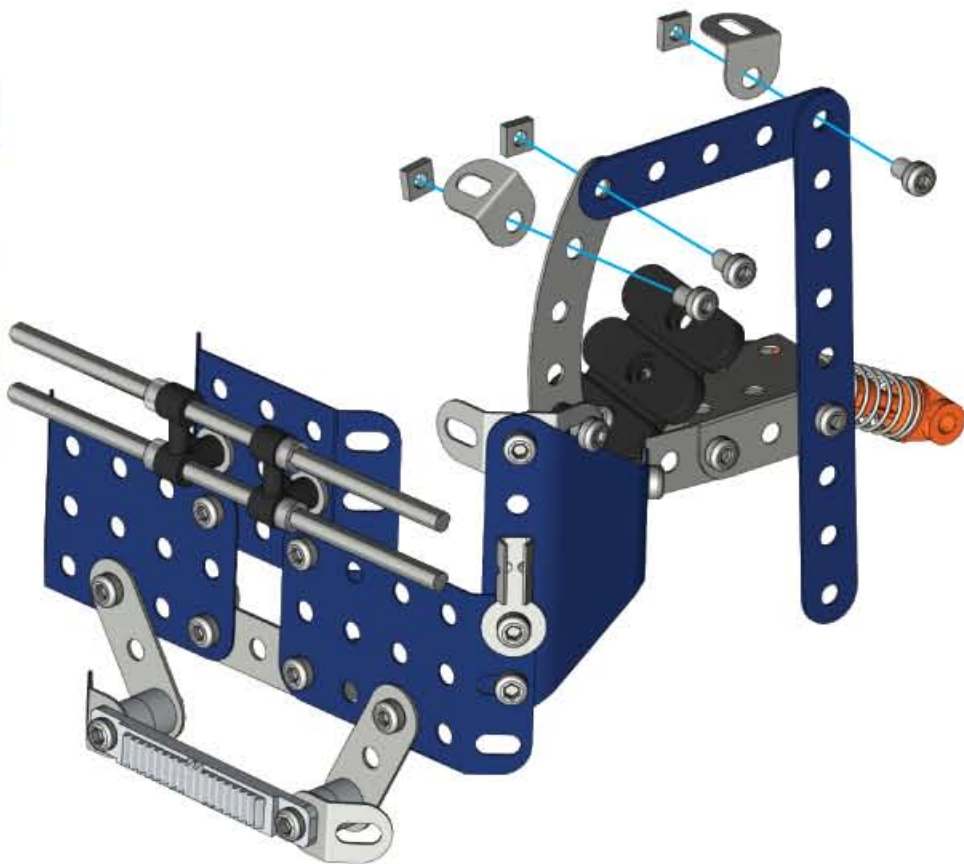
**34**

-  x1
-  x1
-  **B1** | 14,7mm | x1
37/64" |
-  x2

-  **S1** 1:1

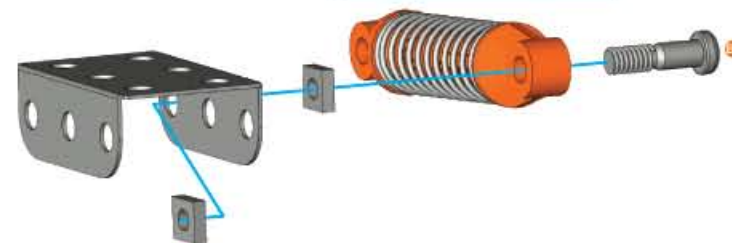
**35**

-  x1
-  x1
-  **S1** | 5,8mm | x2
15/64" |
-  x2

-  **S1** 1:1

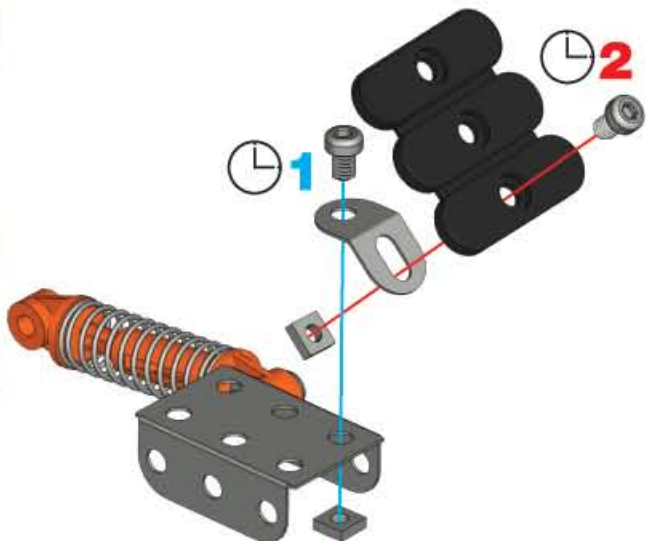
**36**

-  x1
-  x1
-  **S1** | 5,8mm | x2
15/64" |
-  x2

-  **S1** 1:1

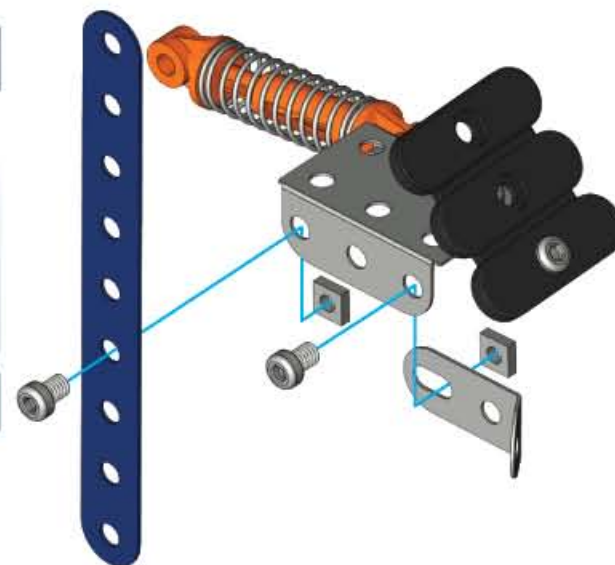

37

x1

x1

x1

x1

1:1

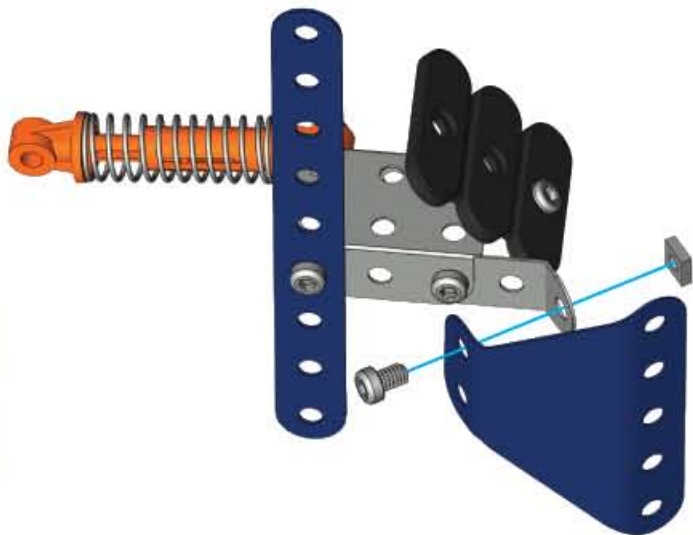

38

x2

x1

x1

1:1

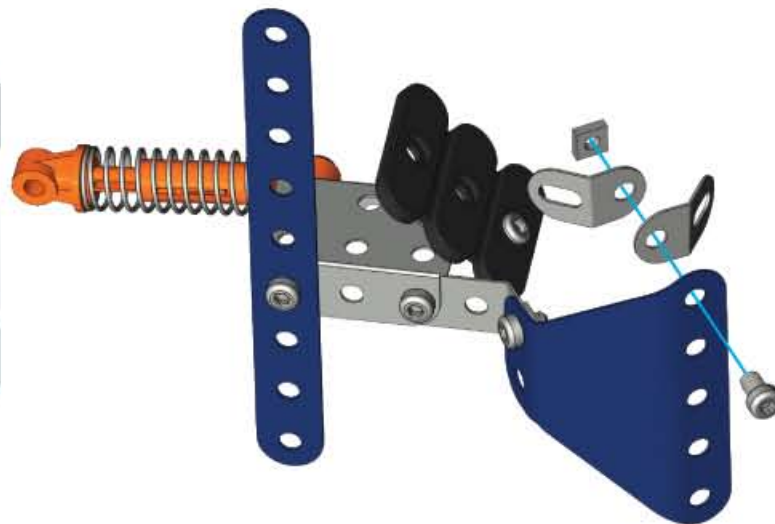

25+38+

39

x1

x2

x2

1:1

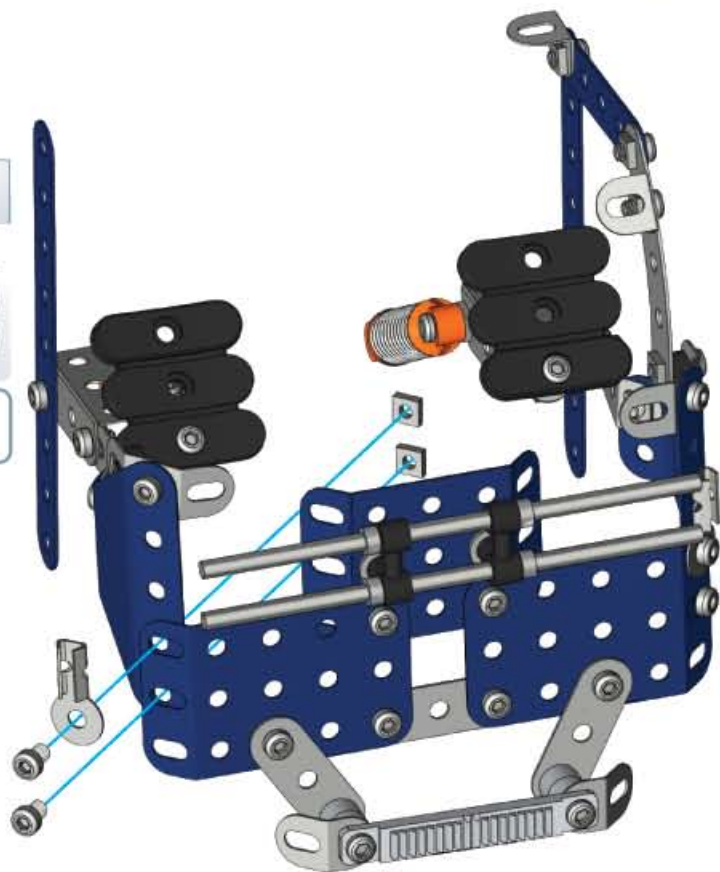

40

x1

x1

x1

x1

1:1

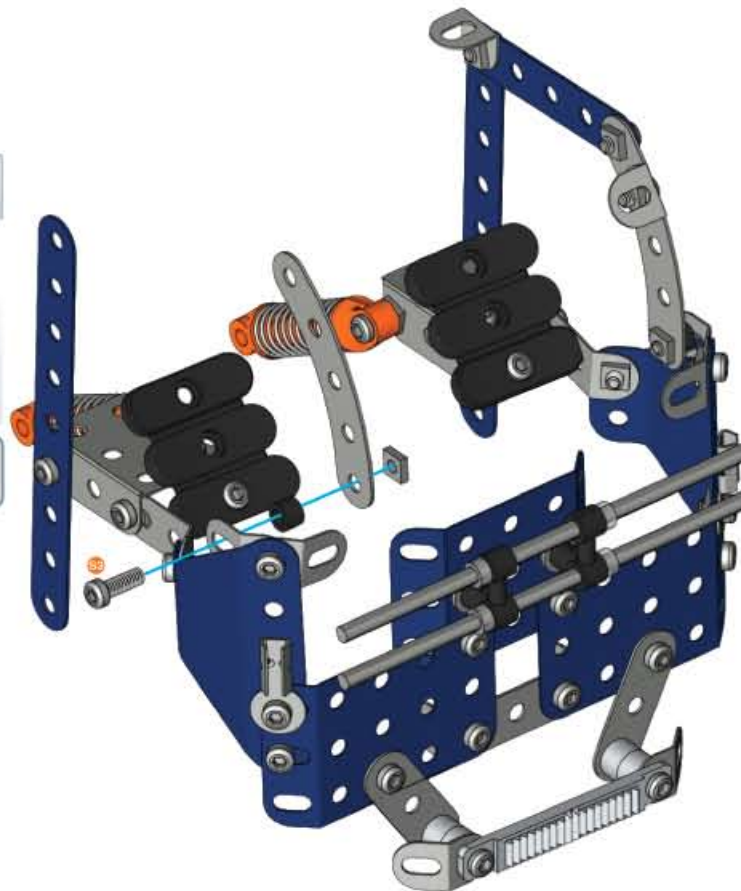

33+40+ **41**

	x1
	x2
	x3
	x3
	1:1

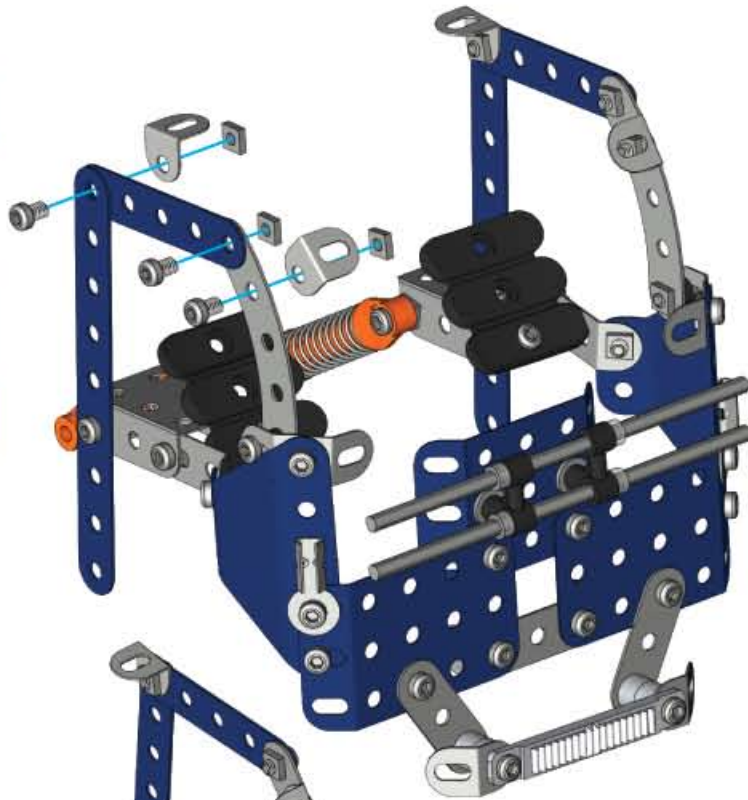

42

	x2
	x2
	x2
	x2
	1:1

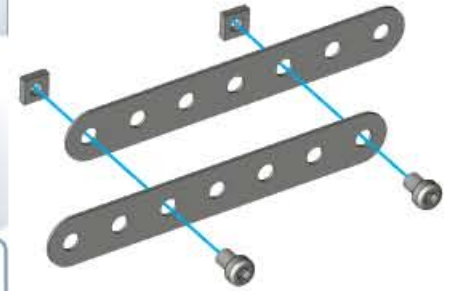

41+42+ **43**

	x2
	x2
	x2
	1:1

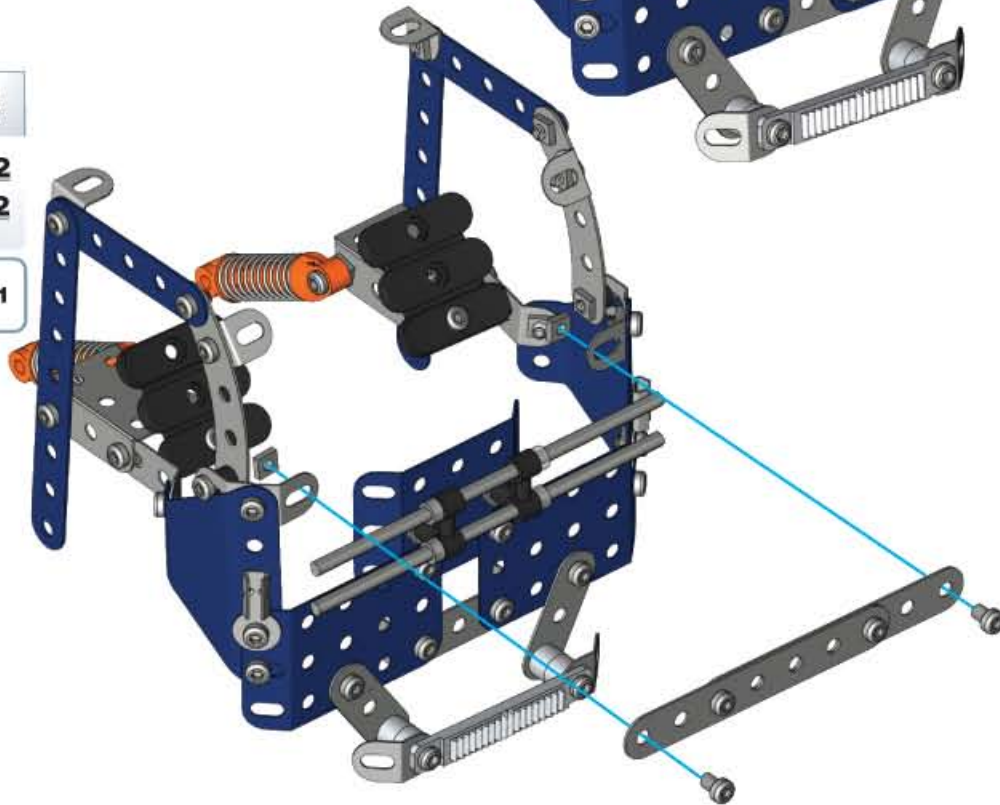

44

	x1
	x1
	x1
	x1
	x1
	1:1

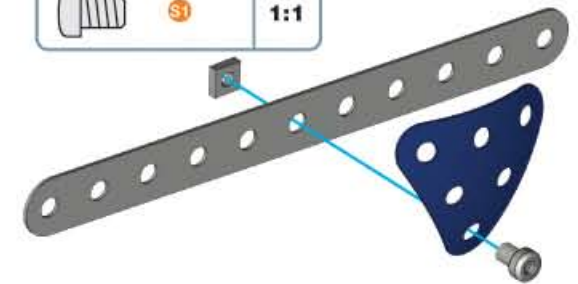

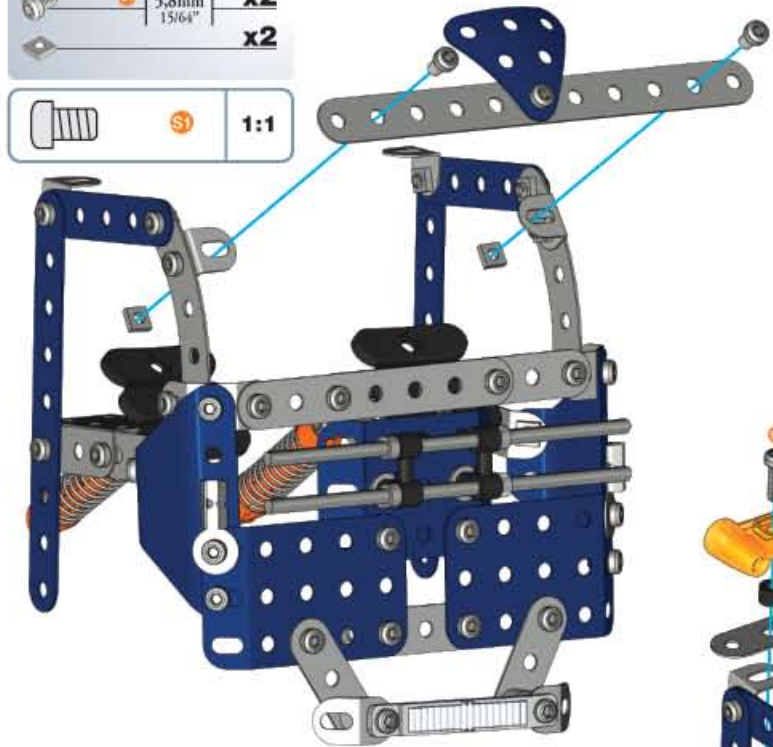

43+44+ **45**

	5,8mm 15/64"	x2
		x2
	S1	1:1







47

	x2
	x2
	x2



46

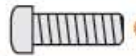

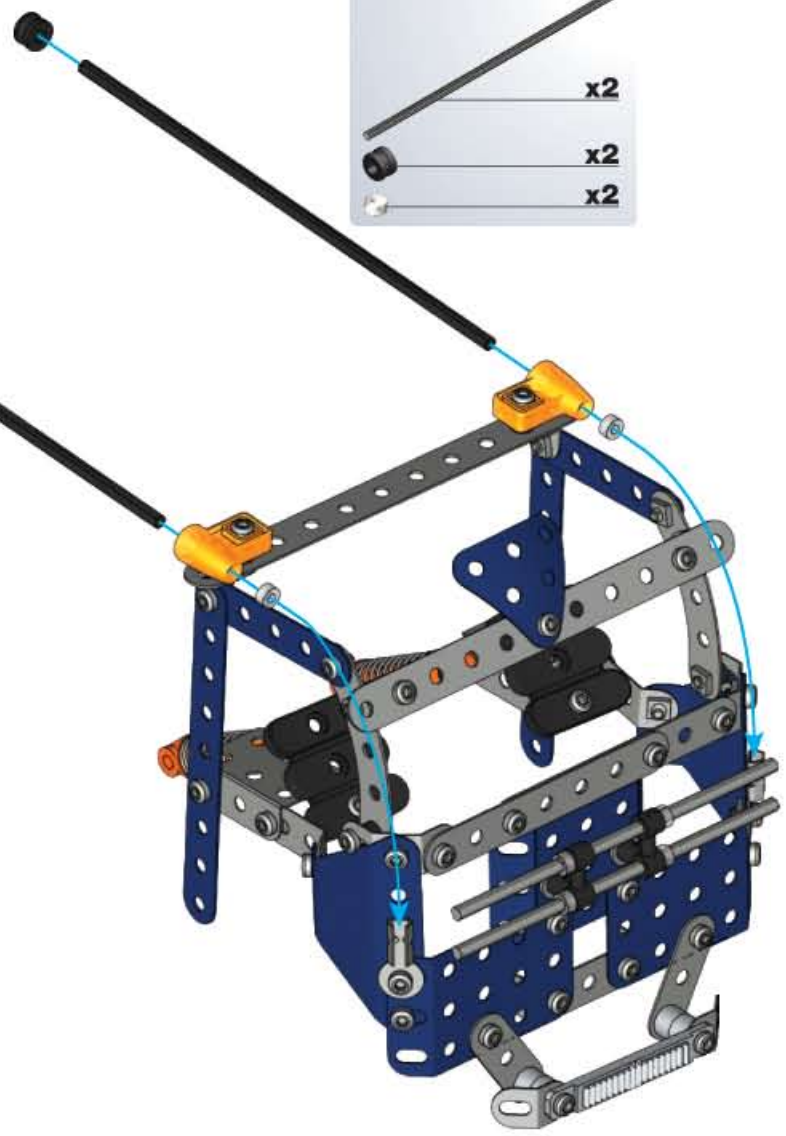
	x1	
	x2	
	x2	
	12mm 1/2"	x2
	x2	
	S3	1:1







19+47+

48

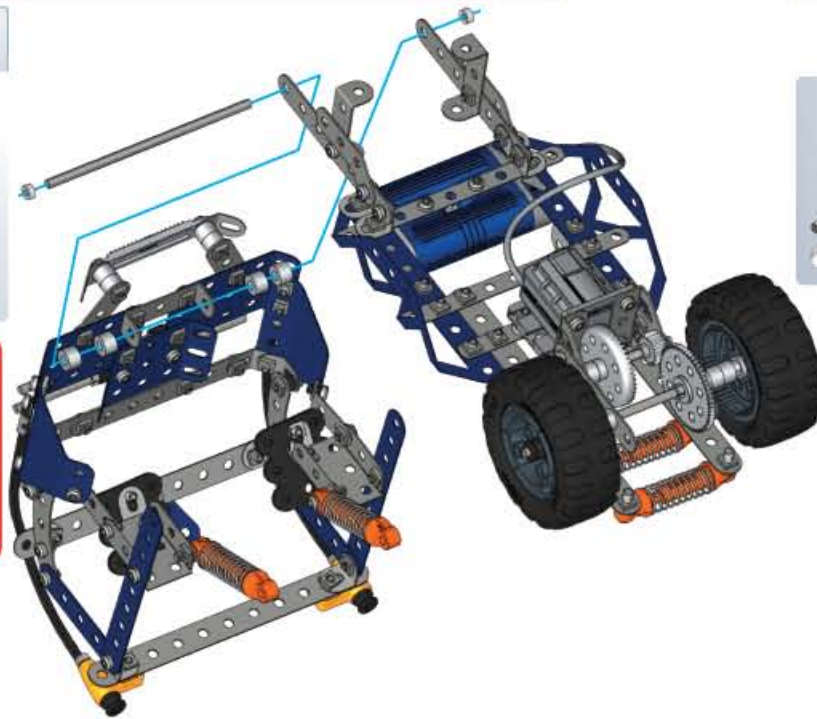
-  100mm | 315/16" | x1
-  x4
-  x2



49

-  100mm | 315/16" | x1
-  x2

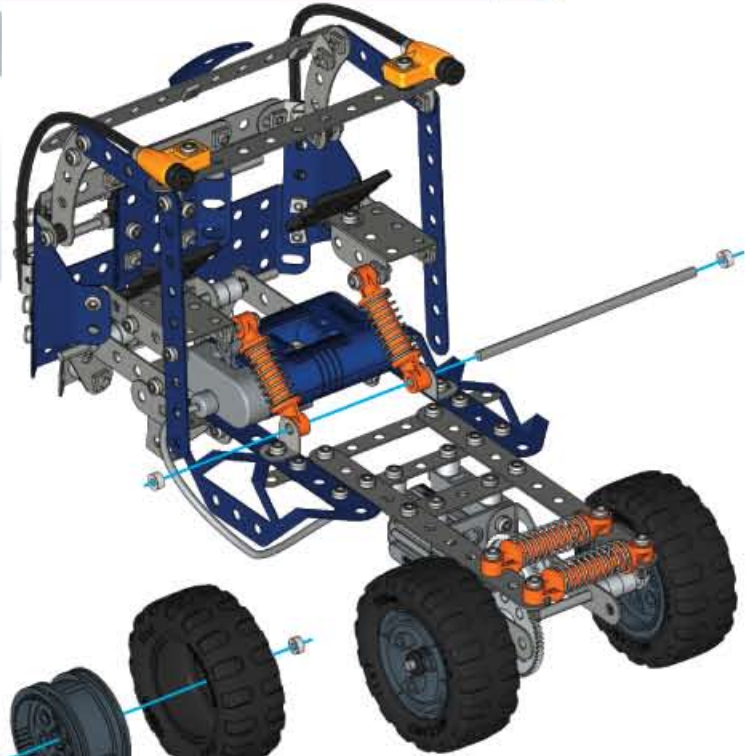

50

-  130mm | 51/8" | x1
-  x2
-  x2
-  x4
-  x2

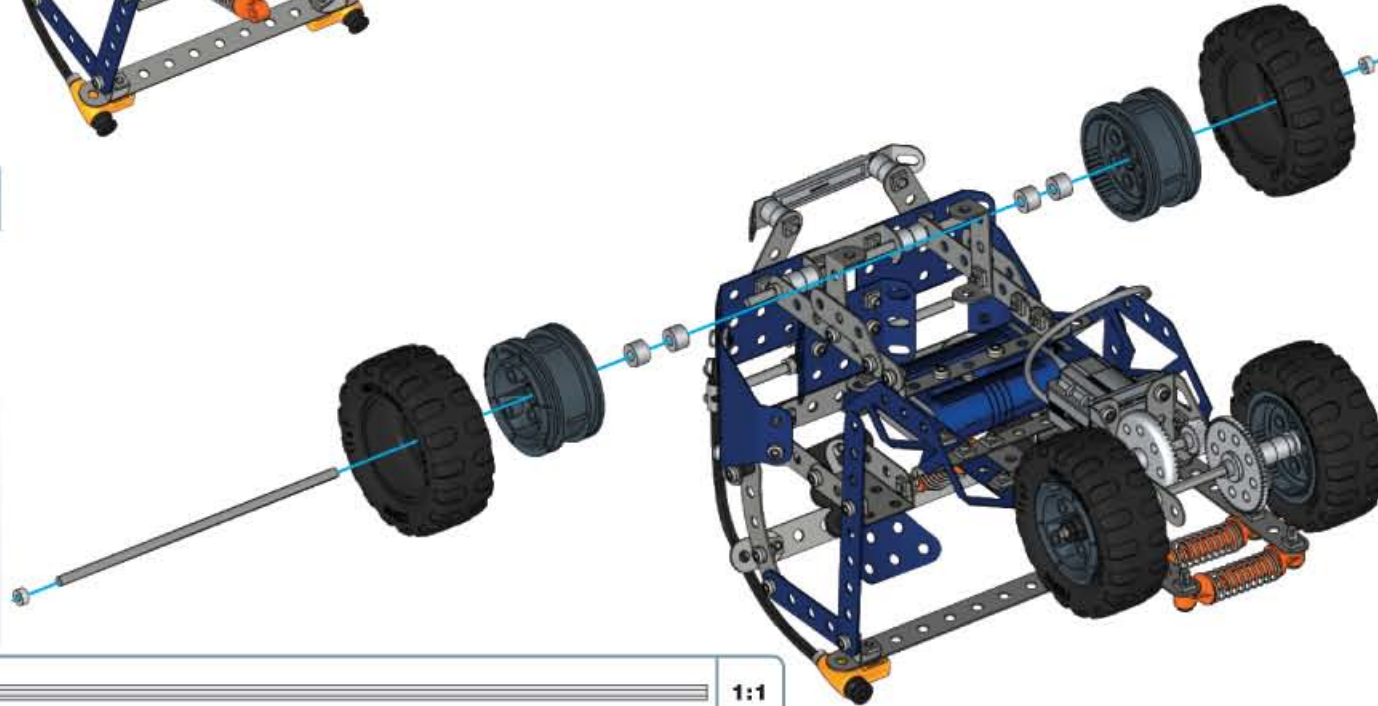



1

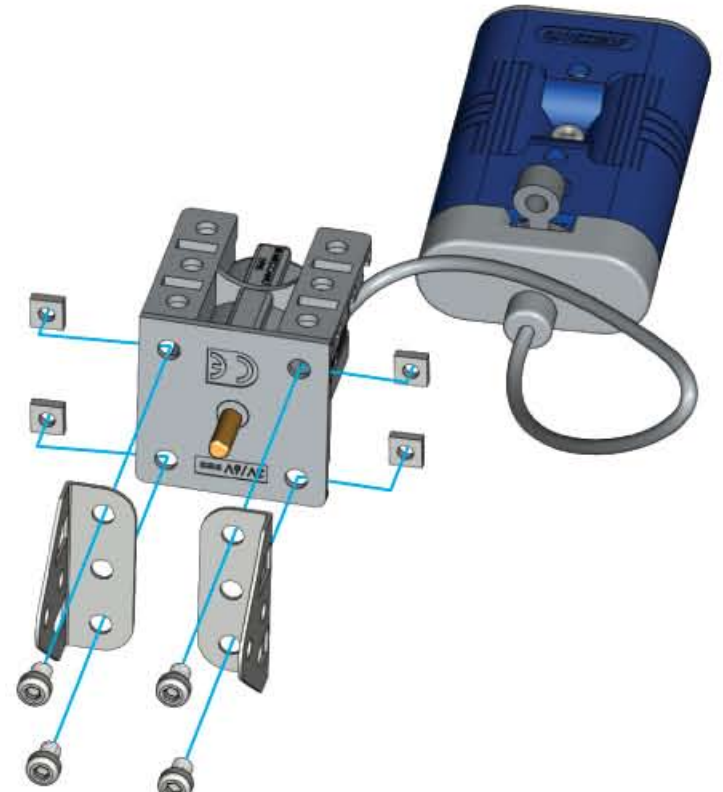
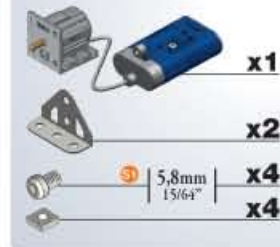

2

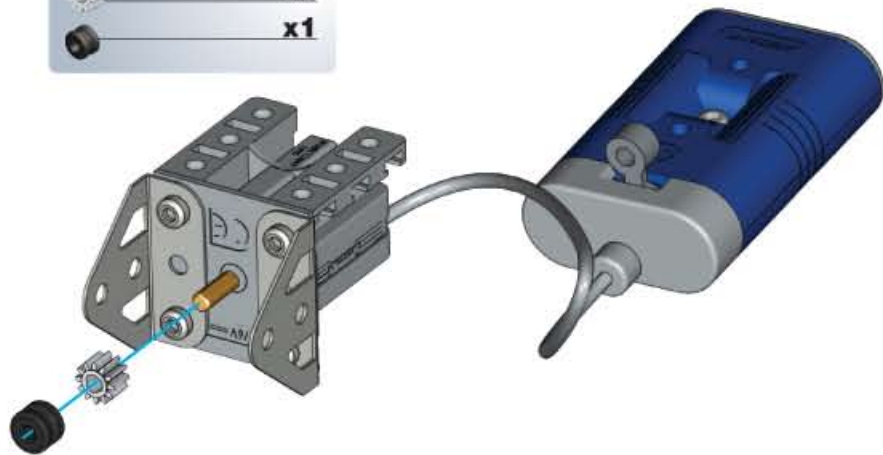

3

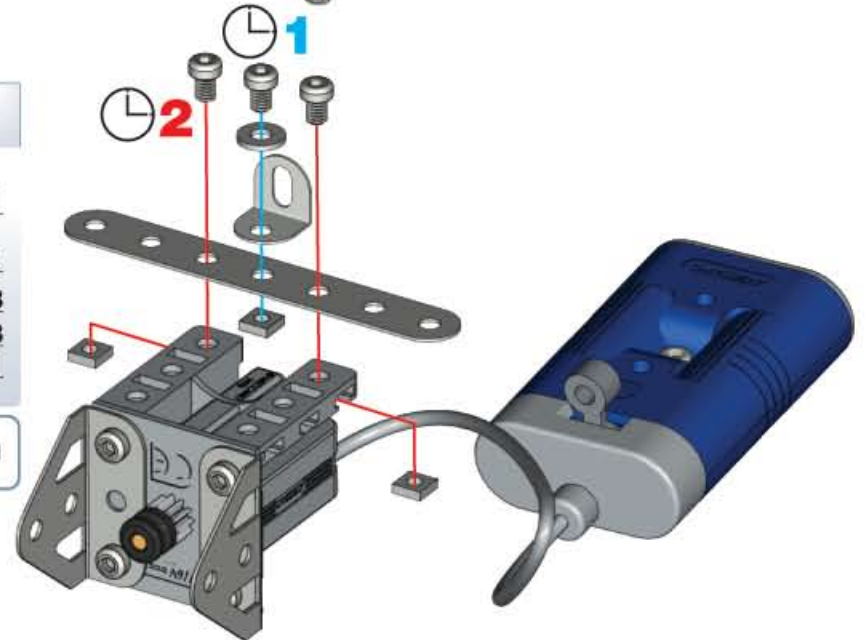

4

	x2
	x2
	x2

	1:1
--	-----

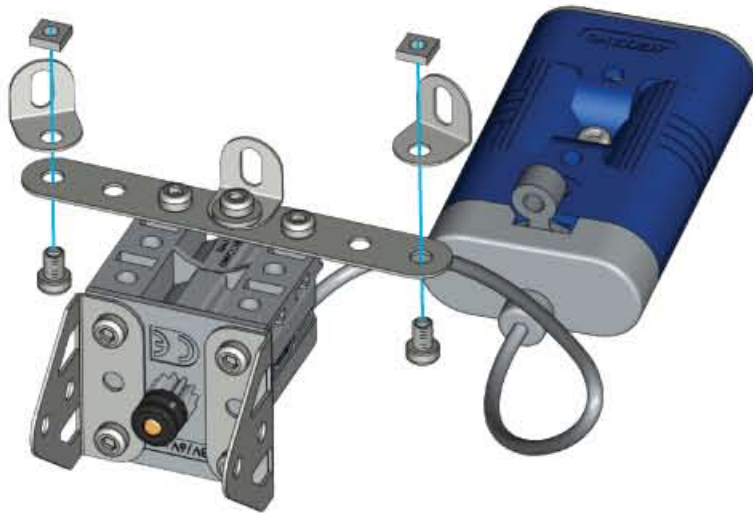

5

	x2
	x1
	x1
	x1

	1:1
--	-----

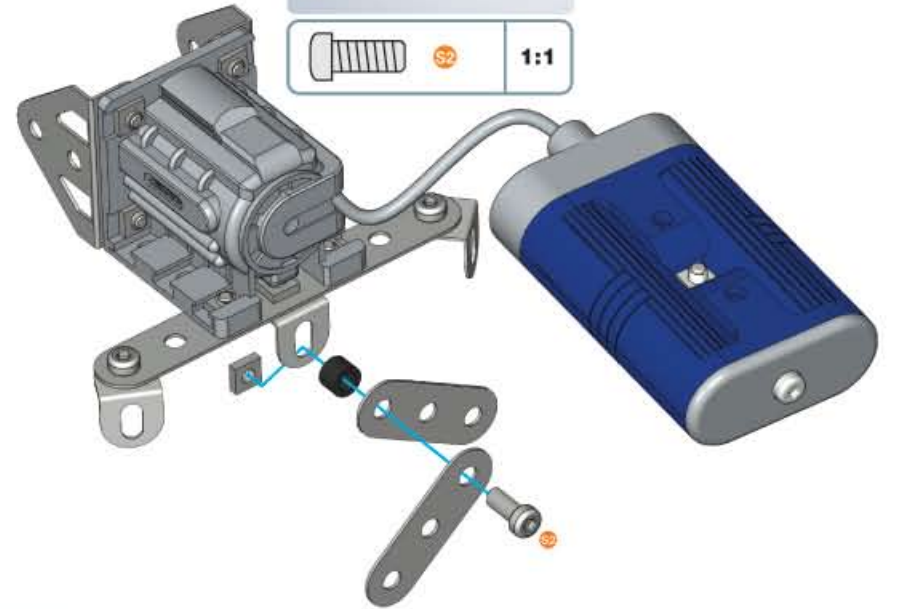

6

	x1
	x2

	1:1
--	-----

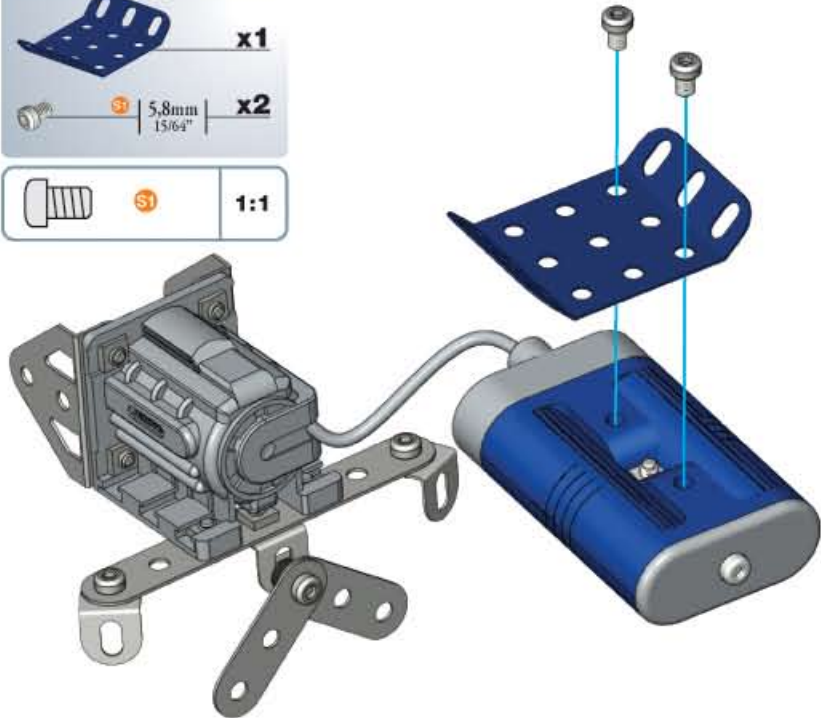

7

	x1
	x2
	x2

	1:1
--	-----

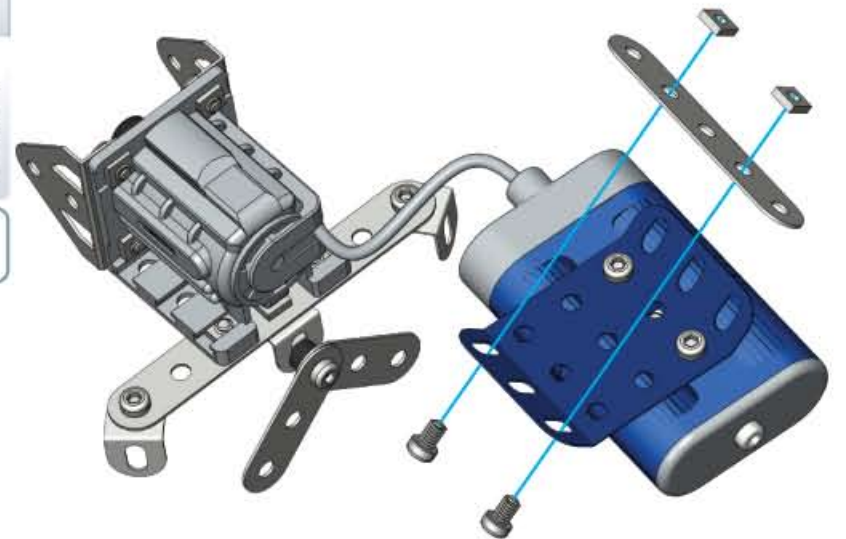

8

	x1
	x1
	x1
	x2
	x3
	x3

	1:1
--	------------

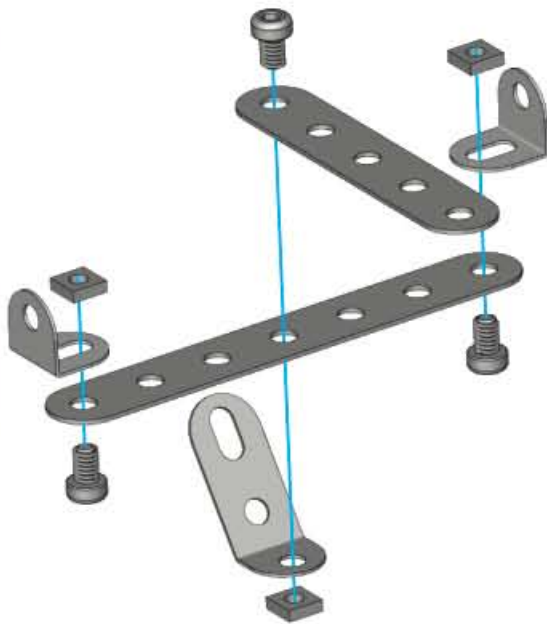

9

	x1
	x1
	x1

	1:1
--	------------

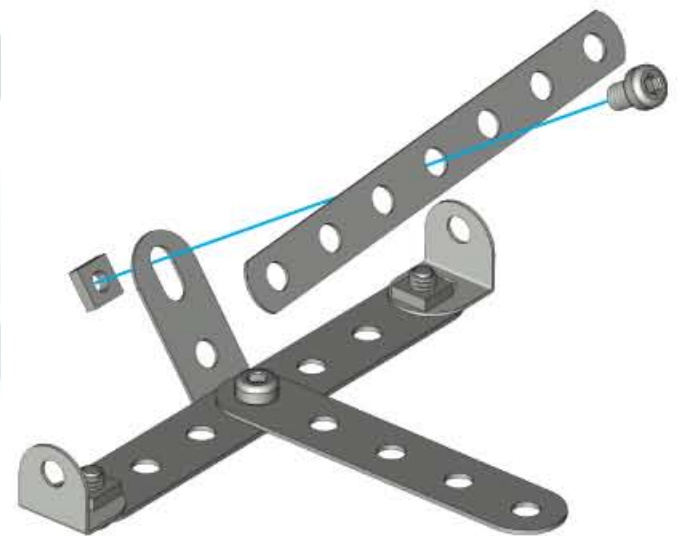

10

	x1
	x1
	x1
	x1
	x1
	x1
	x2

	1:1
	1:1

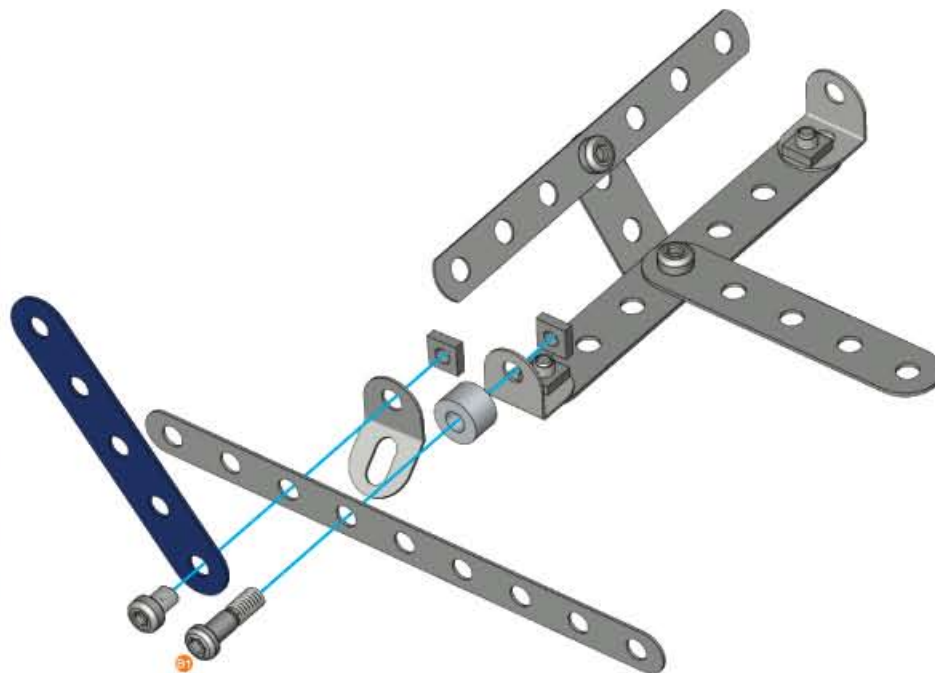

11

	x1
	x1
	x2
	x2

	1:1
--	------------

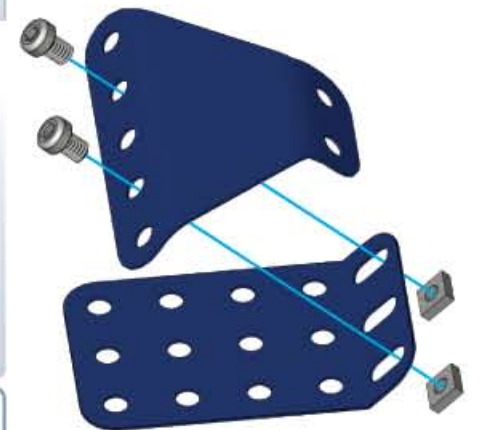

12

	x1
	x1
	x1

	1:1
--	------------

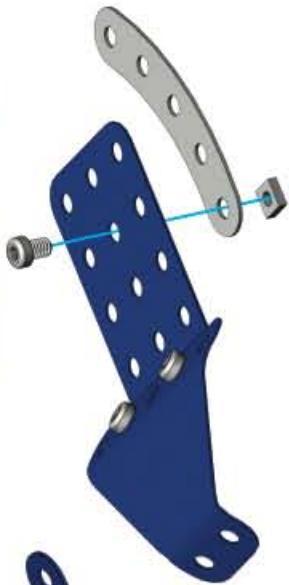

13

	x1
	x1
	x1
	x1

	1:1
--	------------

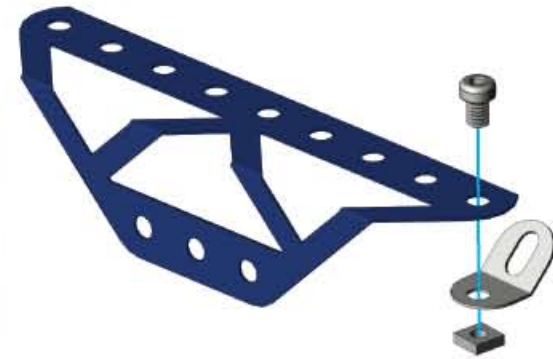

10+12+13+14

	x1
	x1

	1:1
--	------------

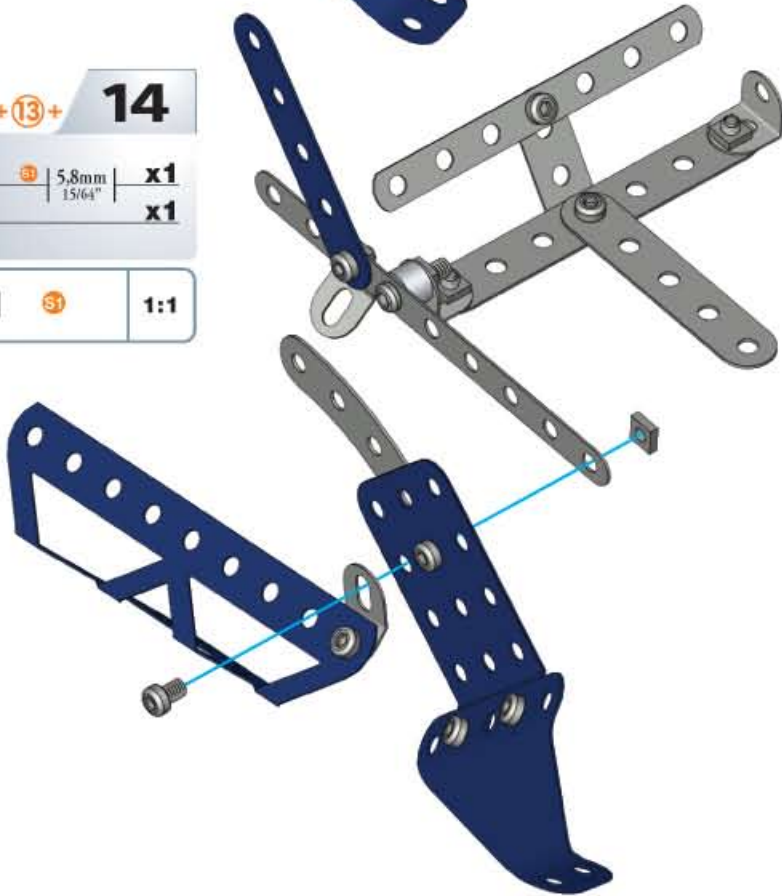

15

	x1
	x1

	1:1
--	------------



16

	x1
	x1
	x2
	x2

	1:1
--	------------

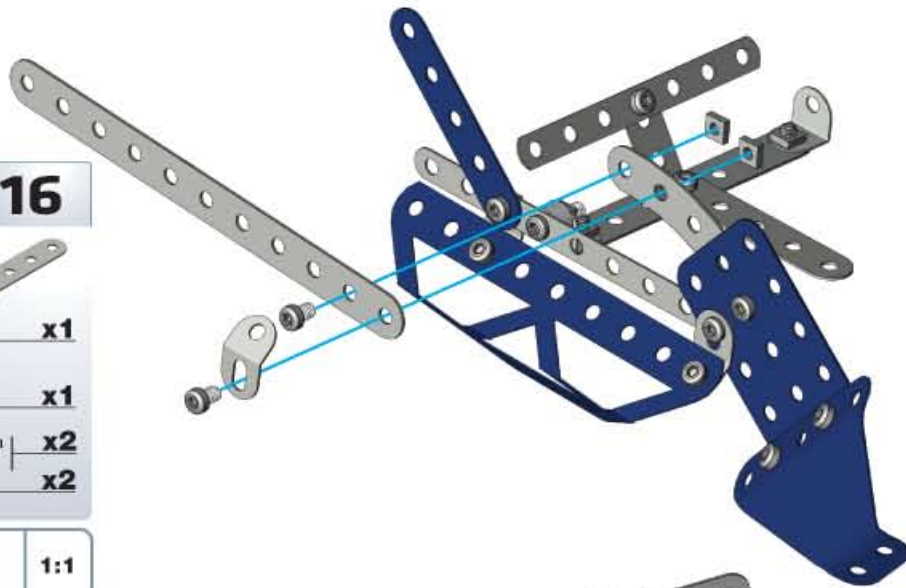

17

	x1
	x1
	x1

	1:1
--	------------

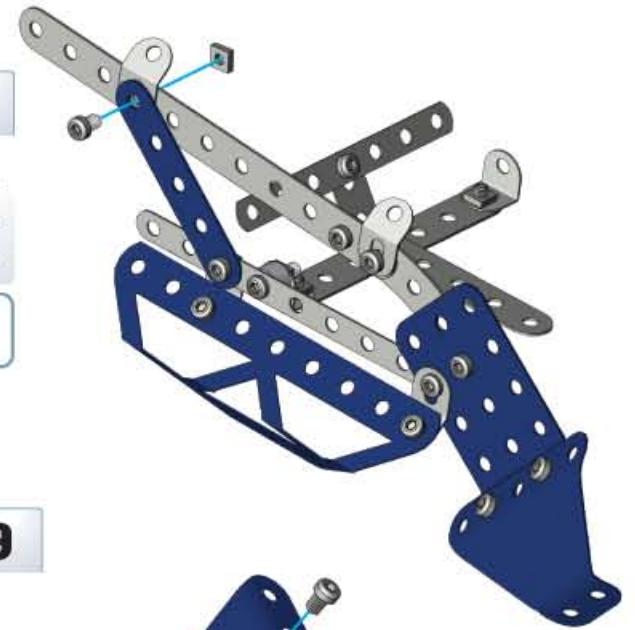

18

	x1		x1
	x1		x1
	x1		x1
	x1		x2

	1:1
	1:1

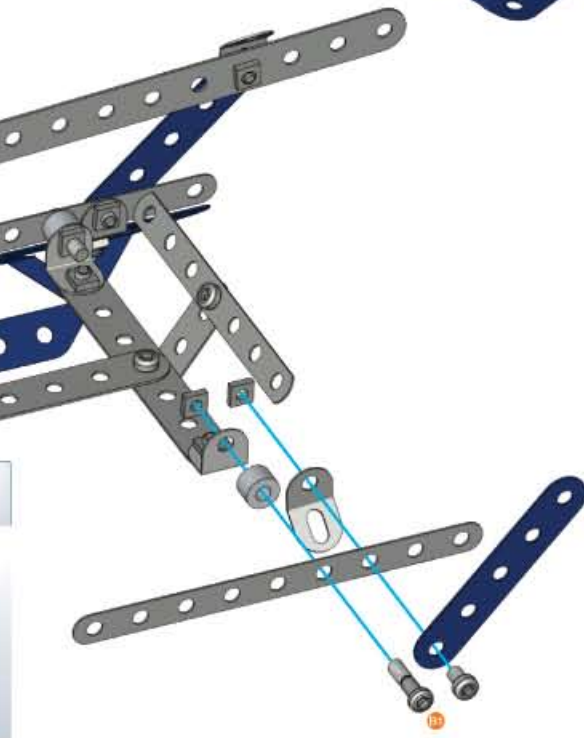

19

	x1
	x1
	x2
	x2

	1:1
--	------------



20

	x1
	x1
	x1

	1:1
--	------------

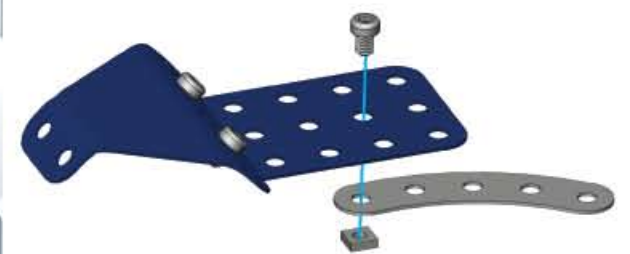

25

	x1
	x1
	x1
	1:1

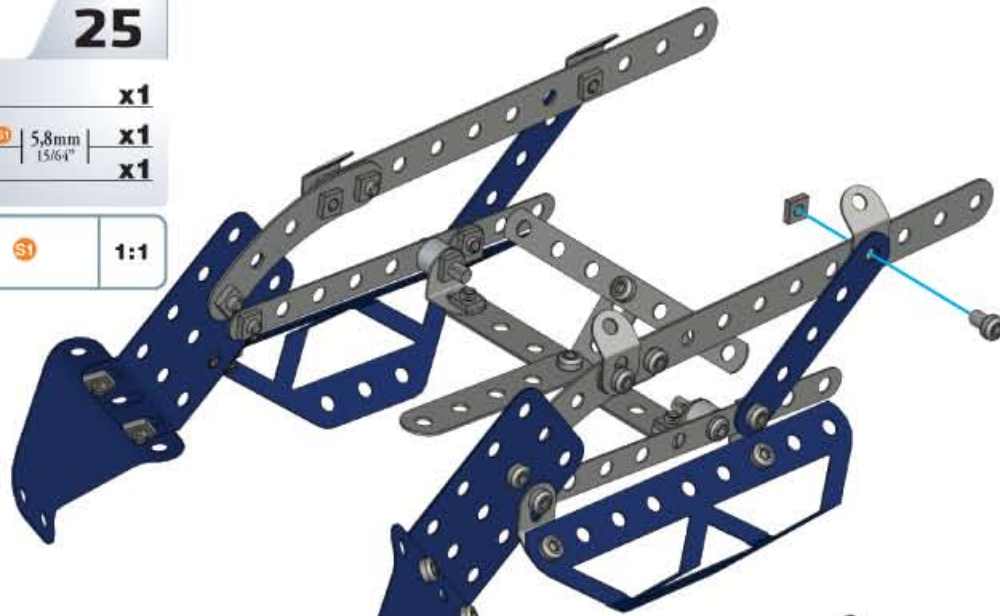

26

	x2
	x2
	x2
	x2
	1:1

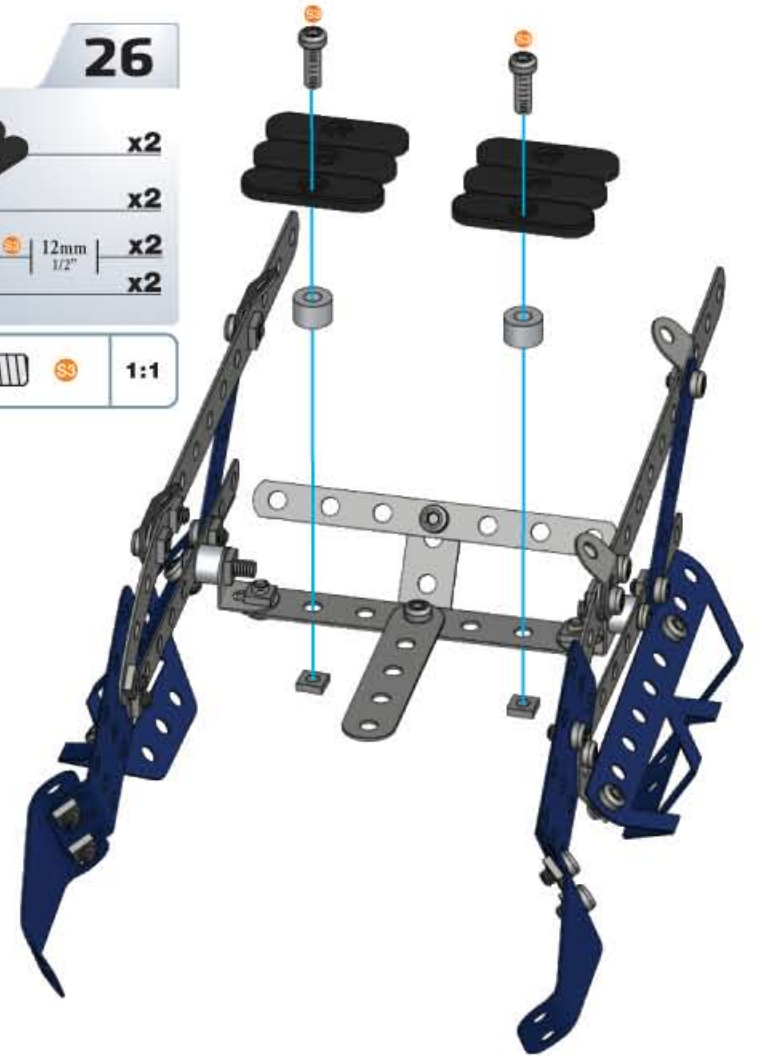





27

	x2
	x2
	1:1



28

-  x2
-  x1
-  x2
-  x4
-  x4

	S1	1:1
---	----	-----

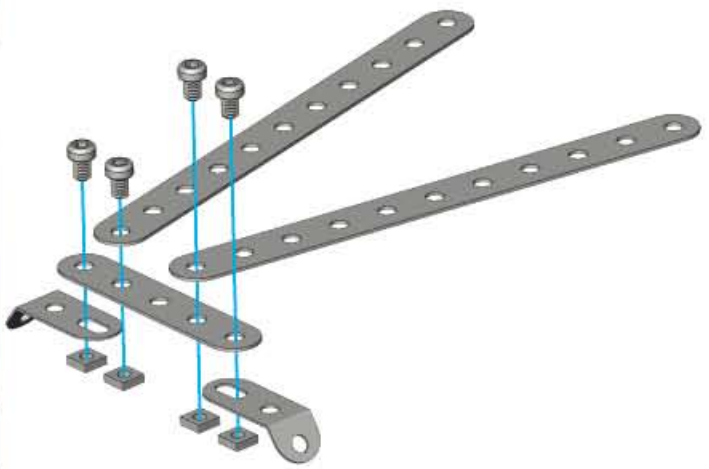

29

-  x1
-  x1
-  x1

	S1	1:1
---	----	-----



30

- 7 + 29 x2
-  x2
-  x2

	S1	1:1
---	----	-----

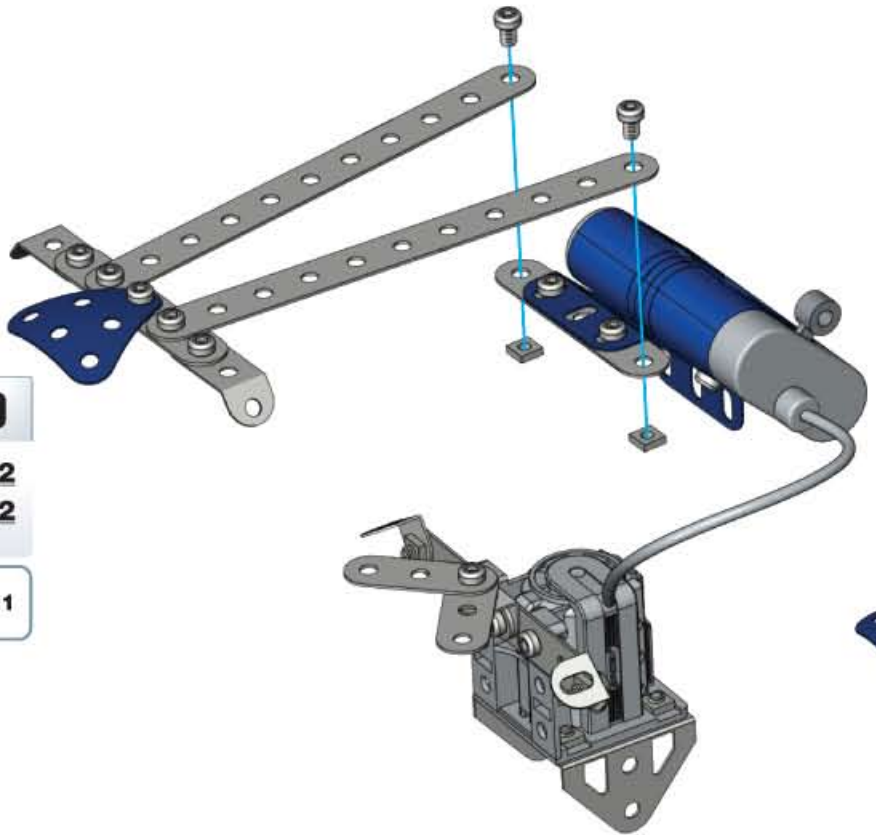

31

-  x2
-  x2

	S1	1:1
---	----	-----

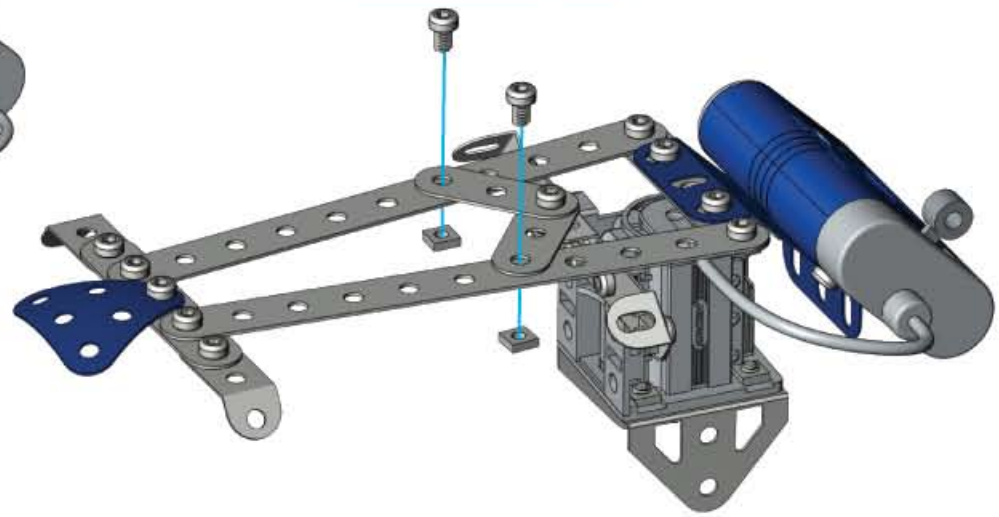

32



(27) + (31) +

-  x1
-  x2
-  x2

 1:1





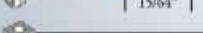

33

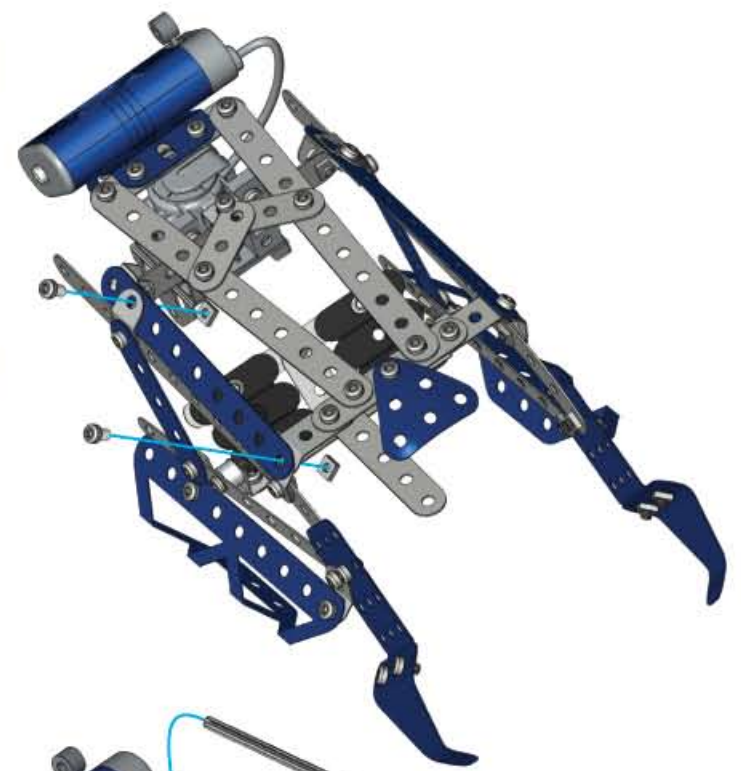
-  x1
-  x2
-  x2

 1:1



34

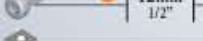

-  x1
-  x1
-  x1
-  x1
-  x1
-  x2

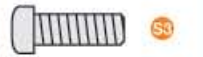
 1:1

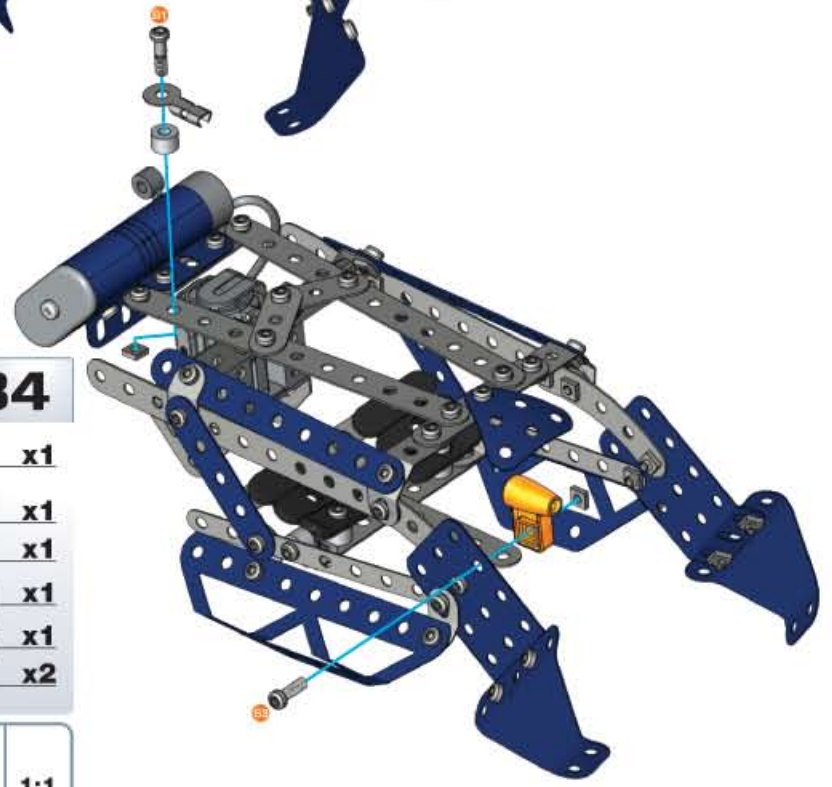
 1:1







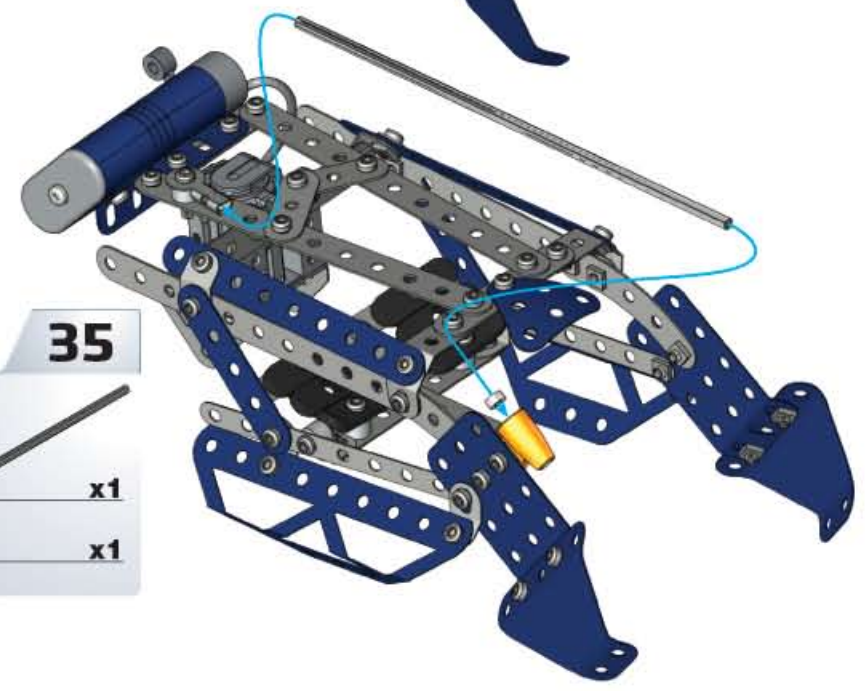



35

-  x1
-  x1





36

-  x1
-  x1
-  x1
-   14,7mm | 37/64" x1
-   12mm | 1/2" x1
-  x2

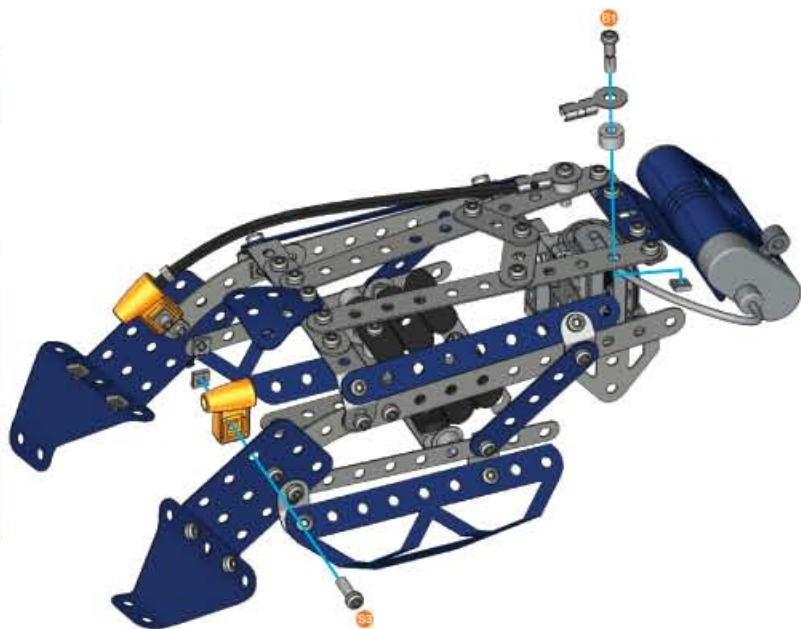
-   1:1
-   1:1





38

-  x1
-  x1
-  x2
-  x2
-  x5
-  x2
-  x2
-  x2
-  x2

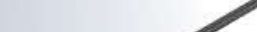

-  1:1

37

-  x1
-  x1

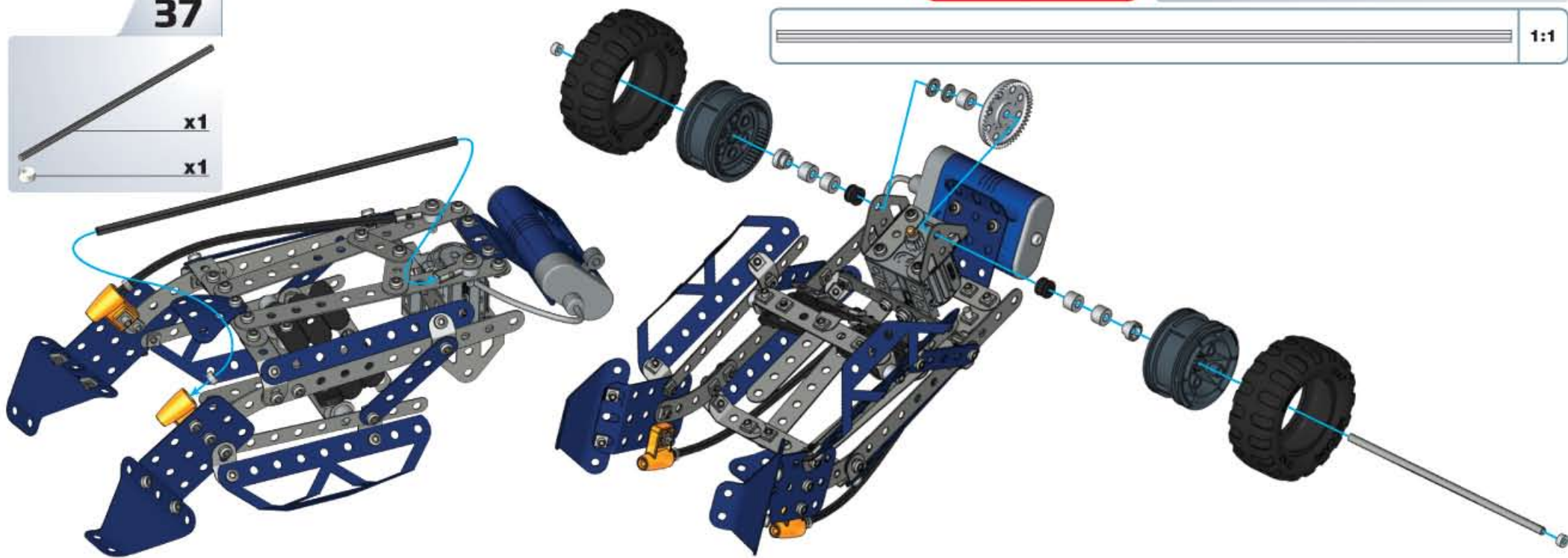



39

- x2
- x2
- x2
- x4
- x4
- 1:1

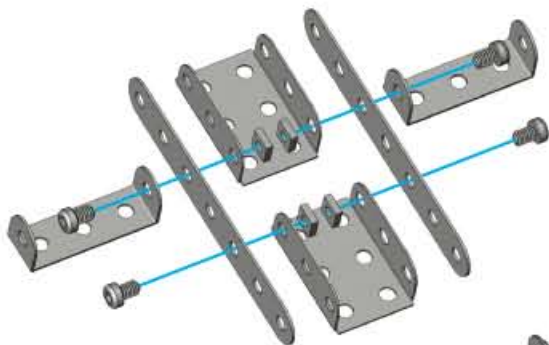

40

- x1
- x1
- x1
- x2
- x2

- 1:1

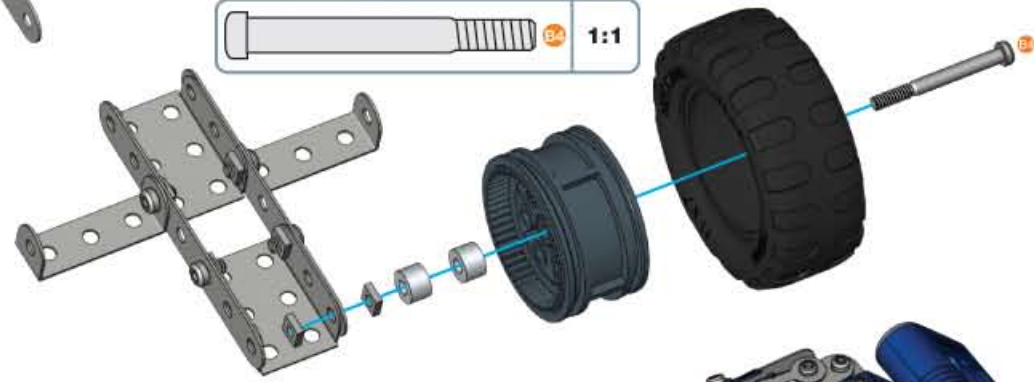

41

- x1
- x1
- x1
- x2
- x2

- 1:1



38 + 41 + 42

- x1
- x2

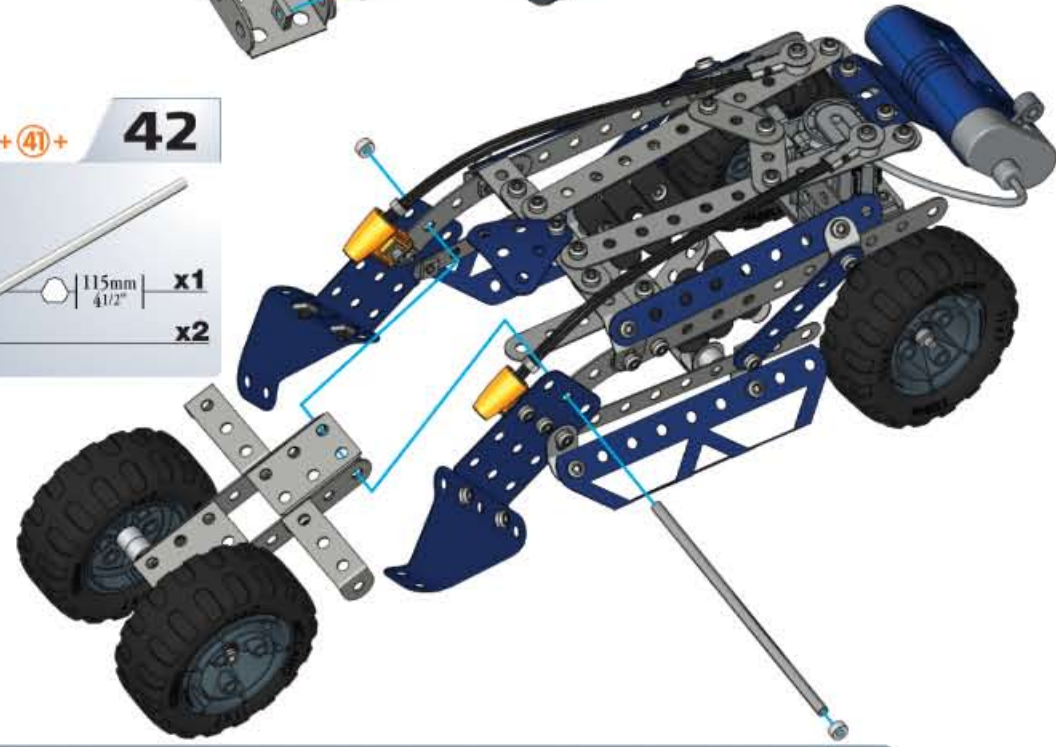



- 1:1

43

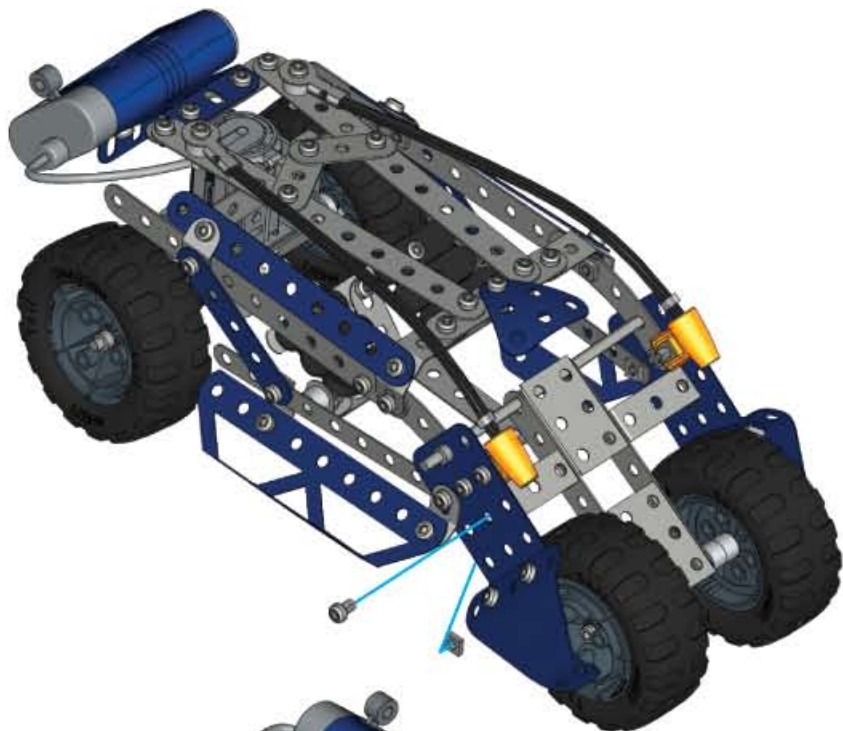
	5,8mm 15/64"	x1
		x1
	S1	1:1



44

	5,8mm 15/64"	x1
		x1
	S1	1:1

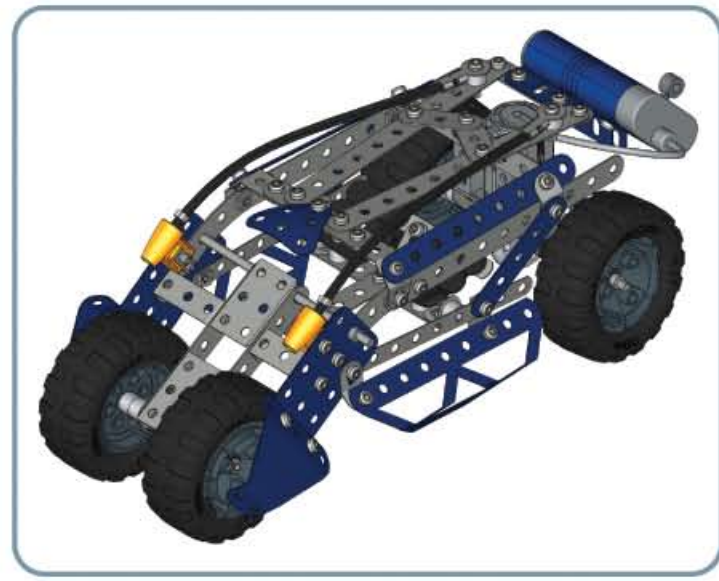
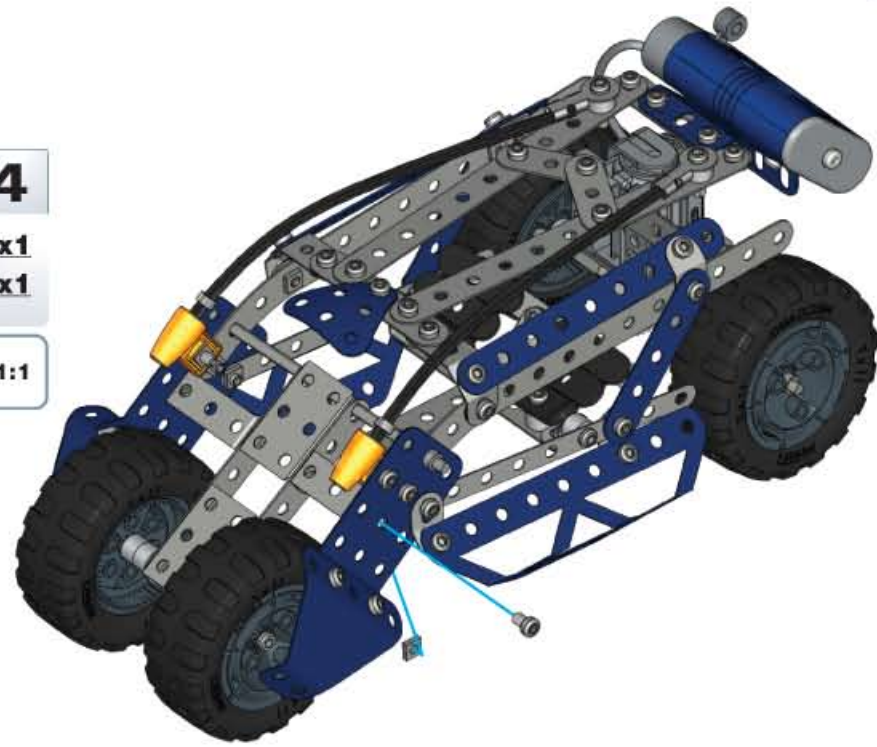

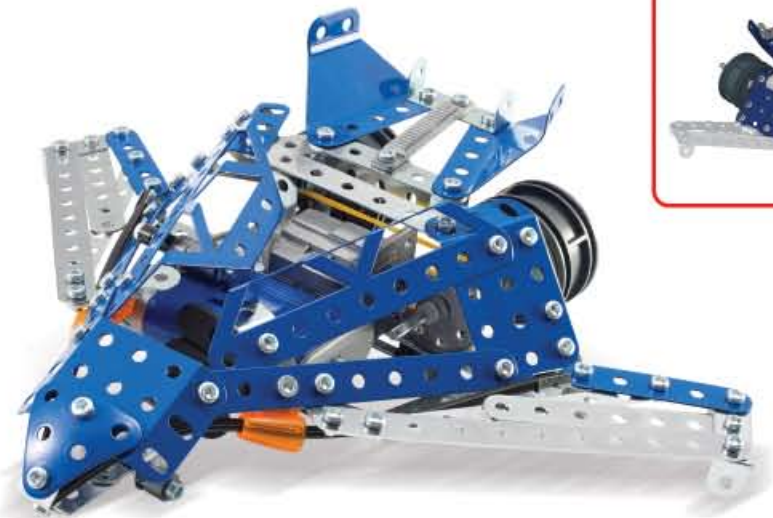



1

- x1
- x1
- x1
- x1
- x1
- x1
- x1

S1 1:1

Scale 1 Escala 1 Mittakaava 1
 Echelle 1 Schaal 1 Määlestok 1
 Maßstab 1 Escala 1 Ковуна 1
 Scala 1 Skala 1 масштаб 1

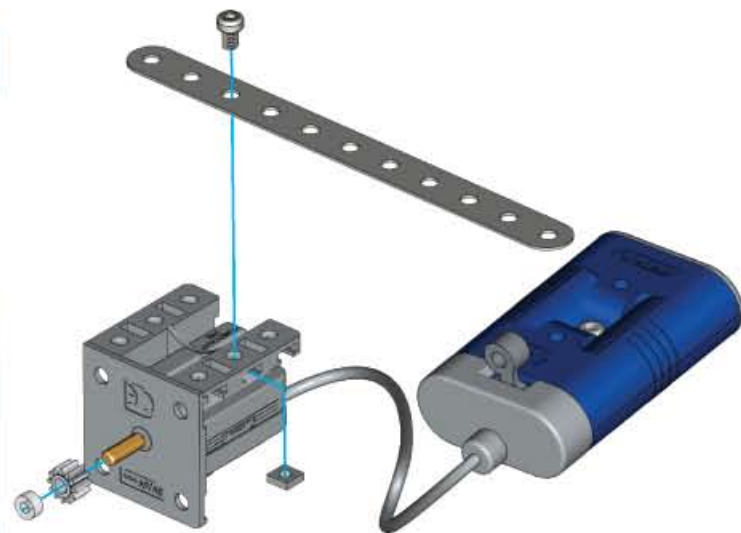
2

- x1
- x1
- x2
- x2

S1 1:1

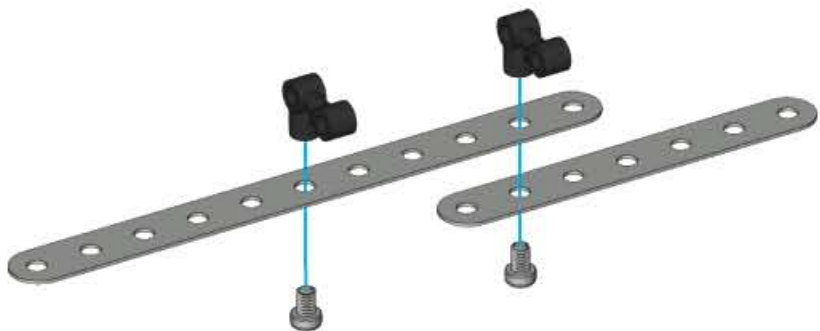

3

- x1
- x2
- x2
- x2

S1 1:1

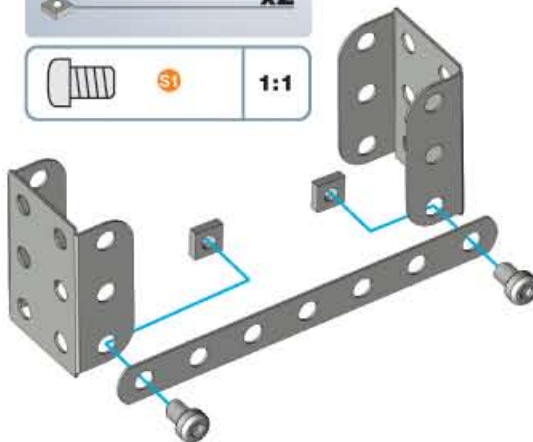

4

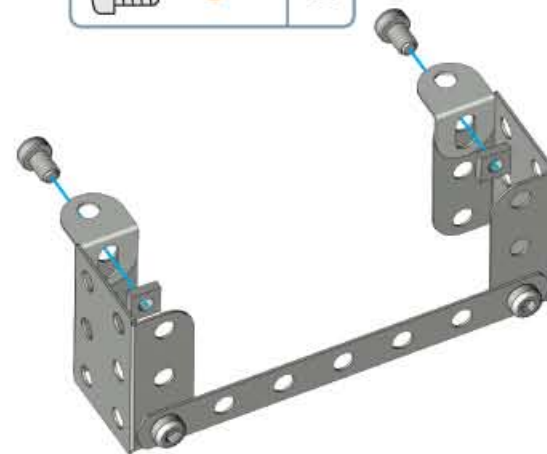

- x2
- x2
- x2

S1 1:1



5

② + ④ +

	5,8mm 15/64"	x2
		x2

	S1	1:1
--	----	-----

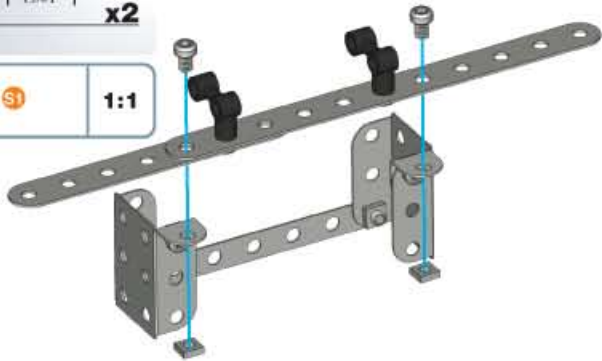

6



① + ⑤ +

	5,8mm 15/64"	x3
		x3
		x1

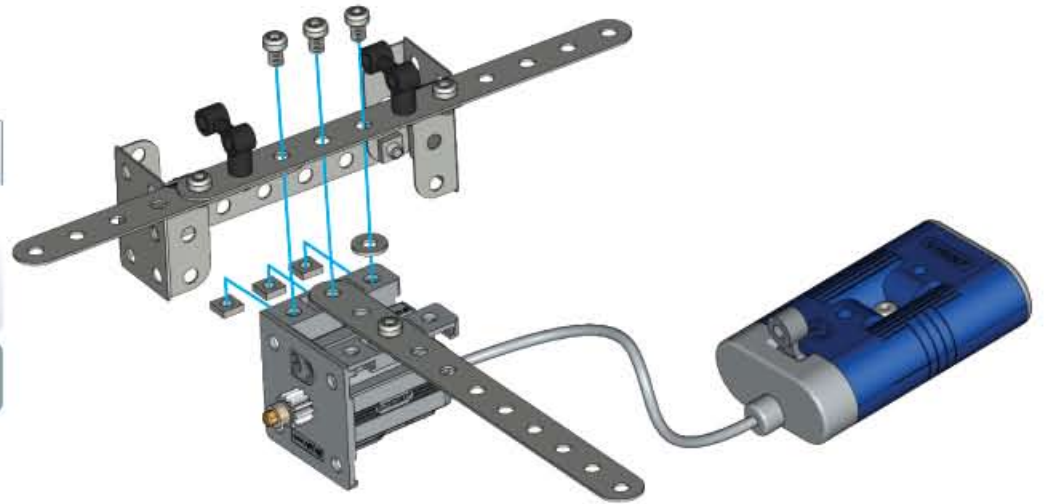
	S1	1:1
---	----	-----





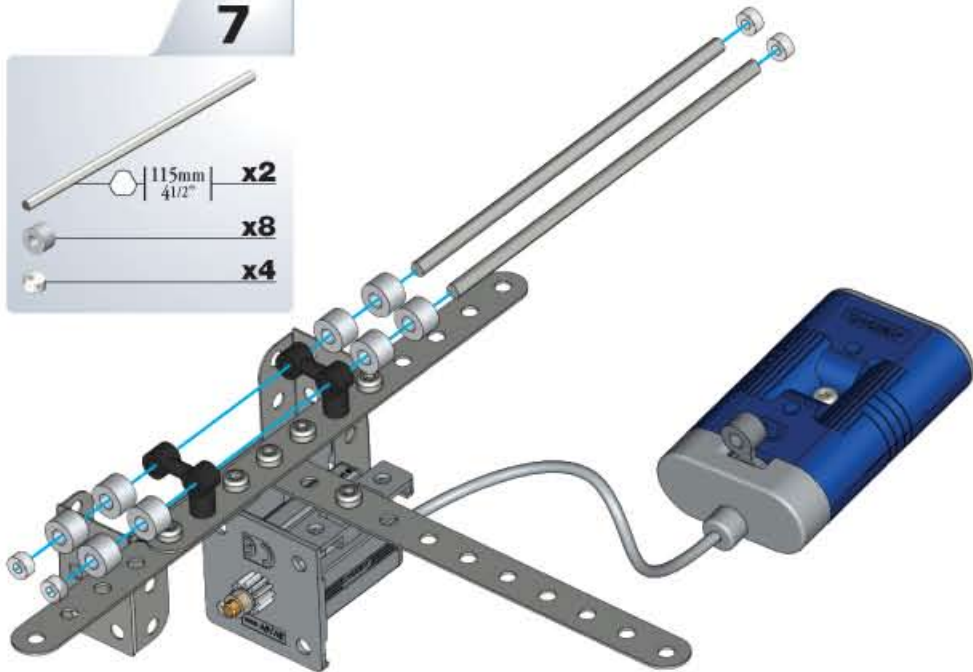

7

	115mm 4 1/2"	x2
		x8
		x4



8

		x2
	5,8mm 15/64"	x1
		x1

	S1	1:1
--	----	-----

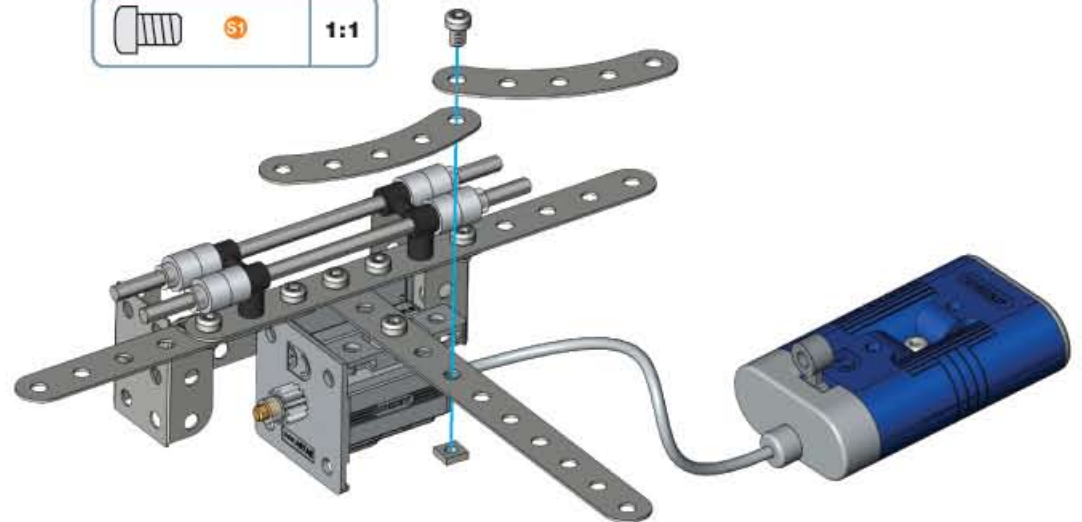

	1:1
--	-----

9

- x2
- x4 | 5,8mm | 15/64"
- x4

- 1:1

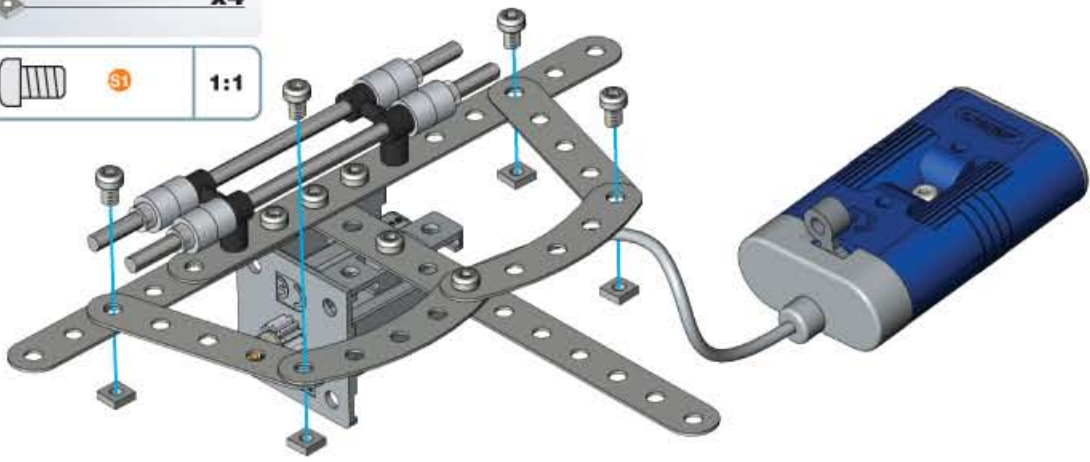

10

- x2 | 12mm | 1/2"
- x2

- 1:1

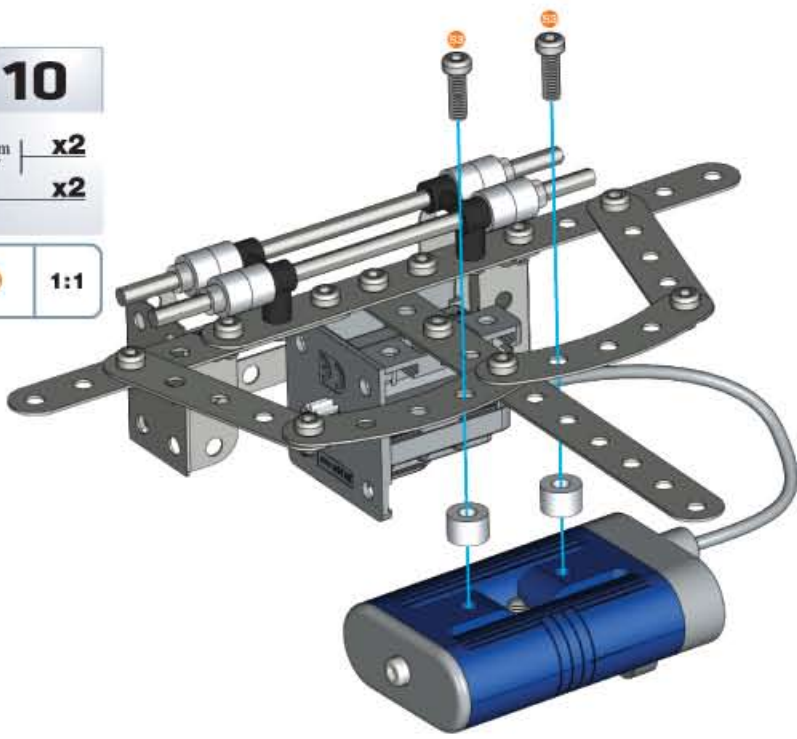

11

- x1
- x1
- x1 | 5,8mm | 15/64"
- x1

- 1:1

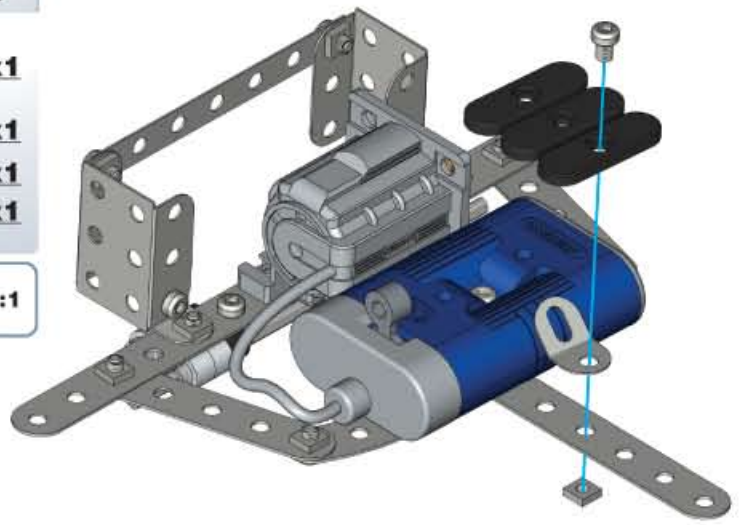

12

- x2
- x2
- x2 | 14,7mm | 57/64"
- x4

- 1:1

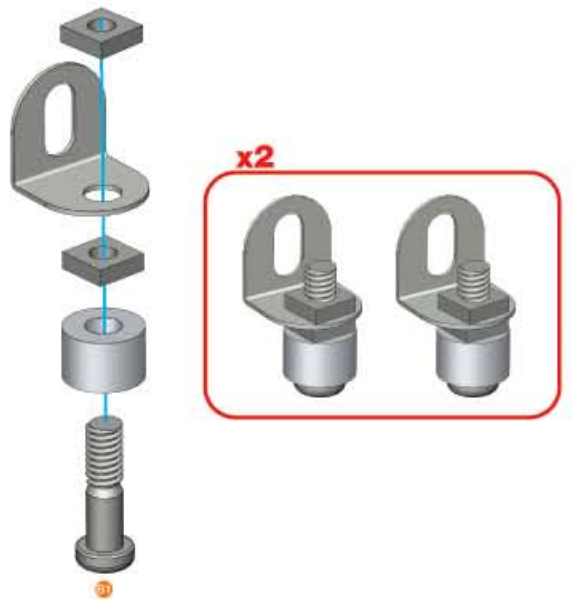

11 + **12** + **13**

	5,8mm 15/64"	x1
		x1
	S1	1:1

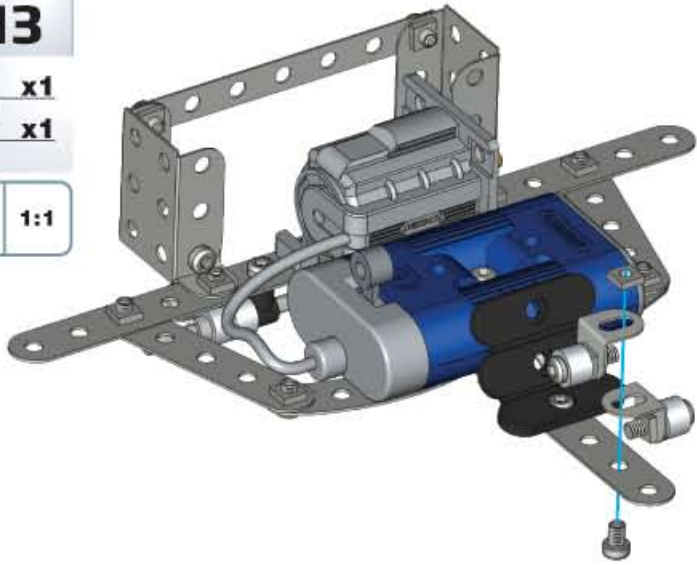





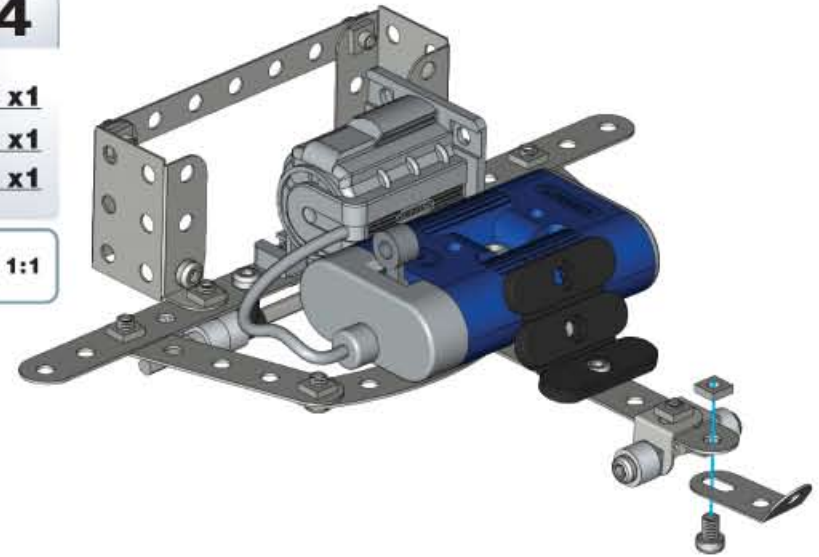

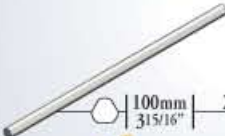

14

		x1
	5,8mm 15/64"	x1
		x1
	S1	1:1



15

	100mm 315/16"	x1
		x1
		x1
		x1
		x1
		x1
		x2
		x1
		x2

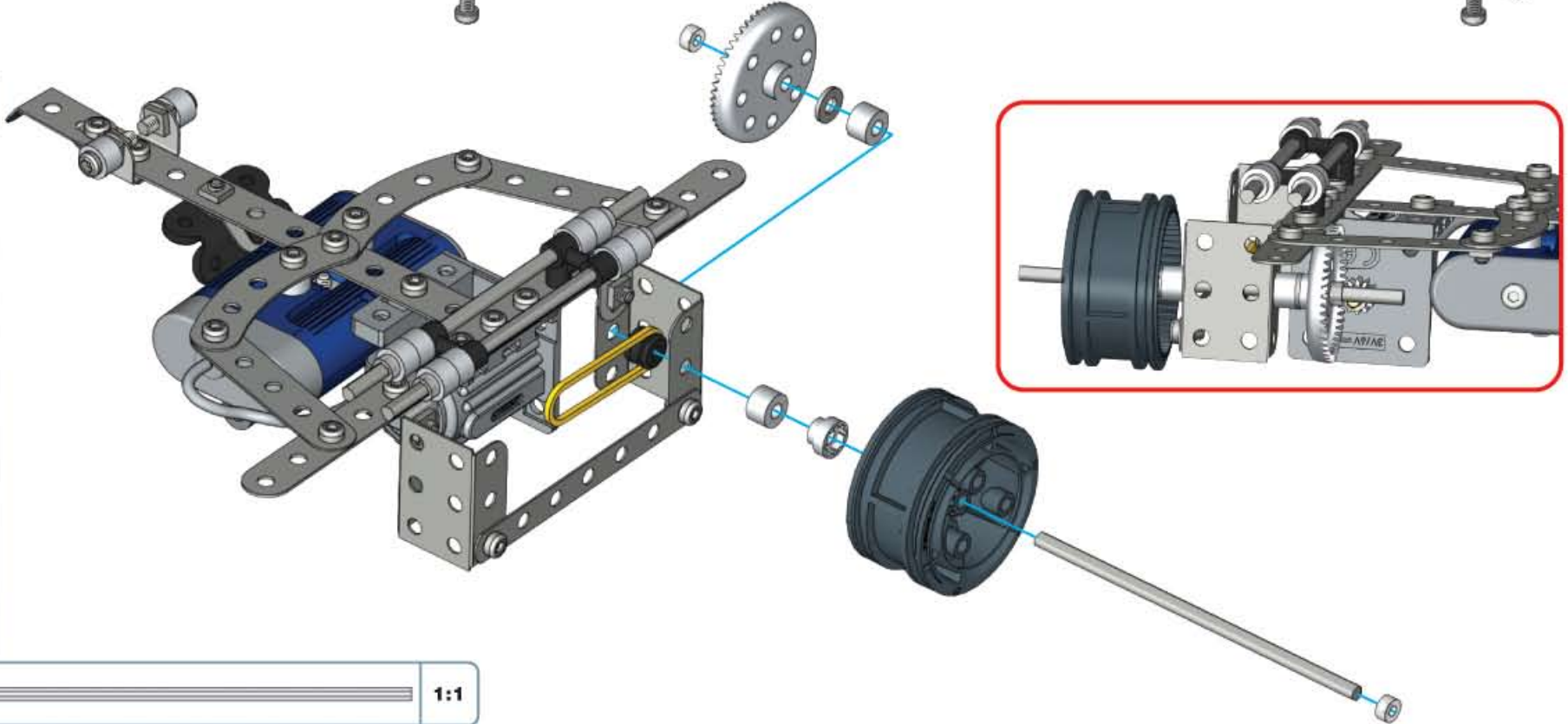

	1:1
--	------------

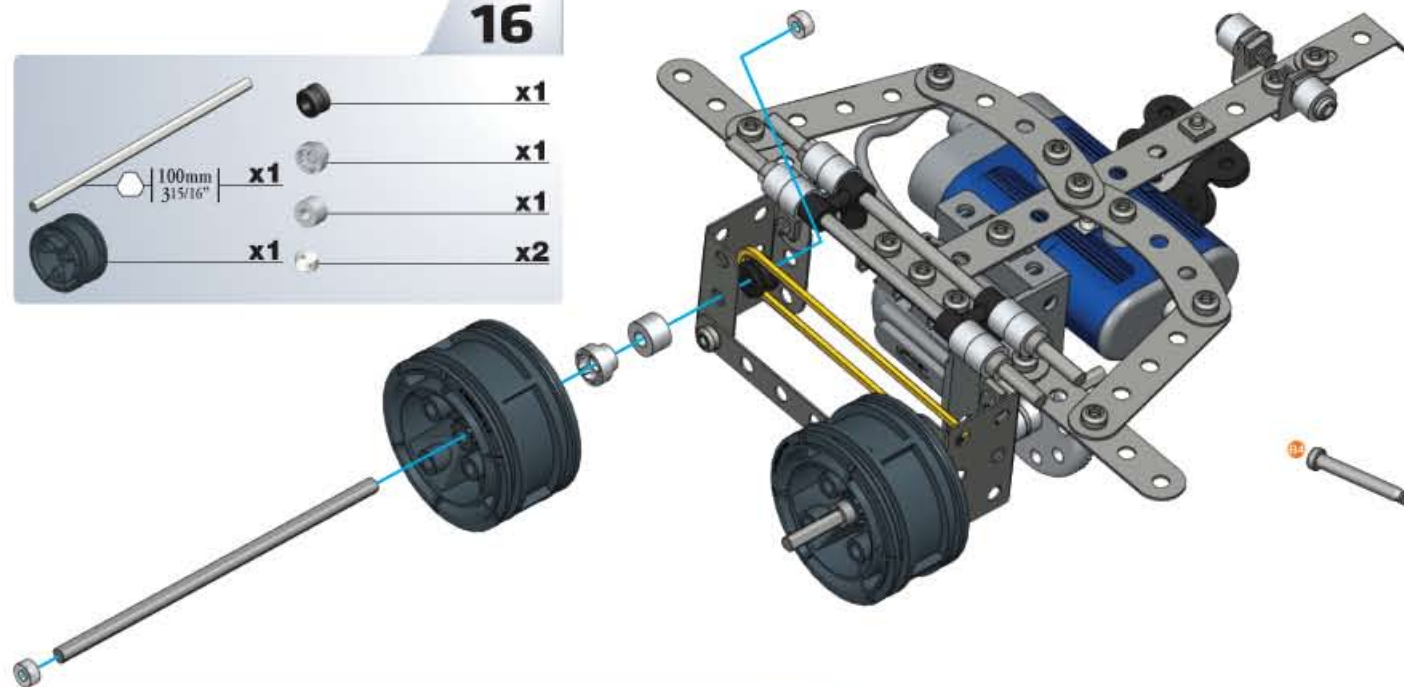
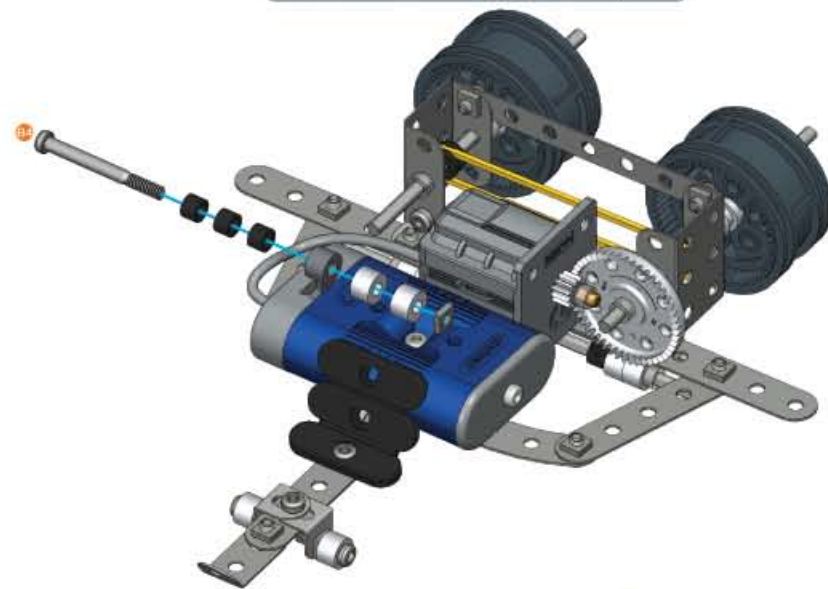
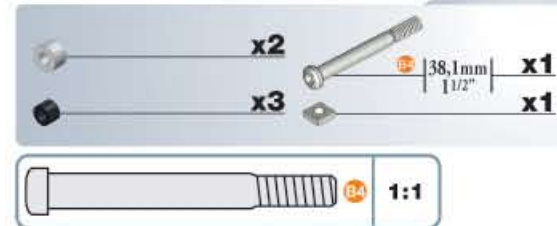
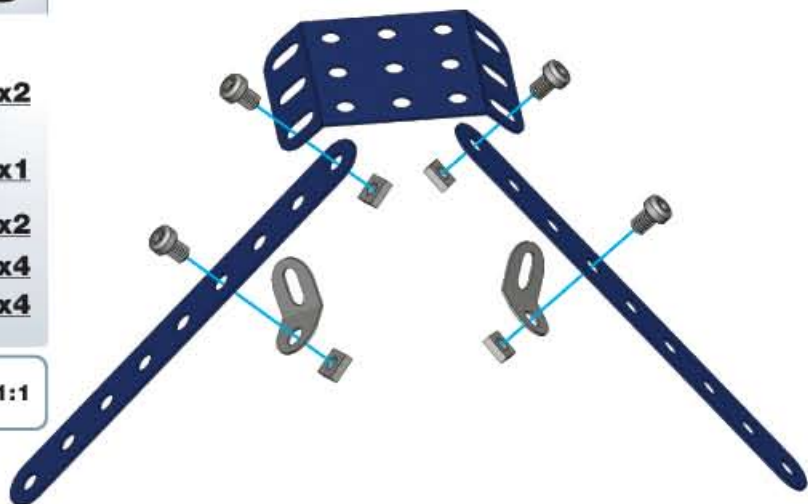
16**17****18****19**

17+19+ **20**

	x1
5.8mm 15/64"	x2
	x2

	1:1
--	------------



21

	x2
	x1
5.8mm 15/64"	x2
	x2

	1:1
--	------------

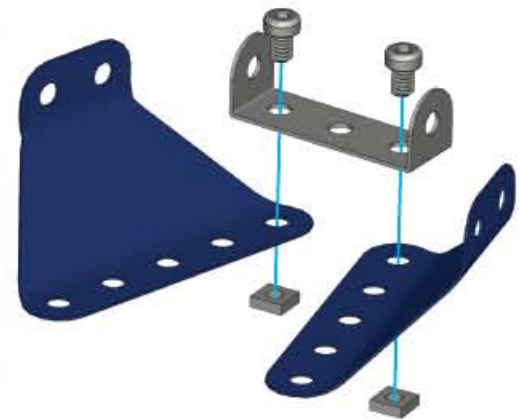

22

	x1
	x1
5.8mm 15/64"	x2
	x2

	1:1
--	------------

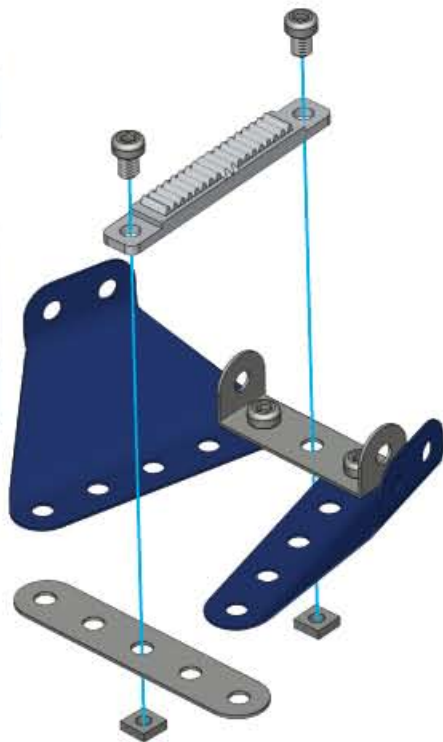

23

	x2
5.8mm 15/64"	x2
	x2

	1:1
--	------------

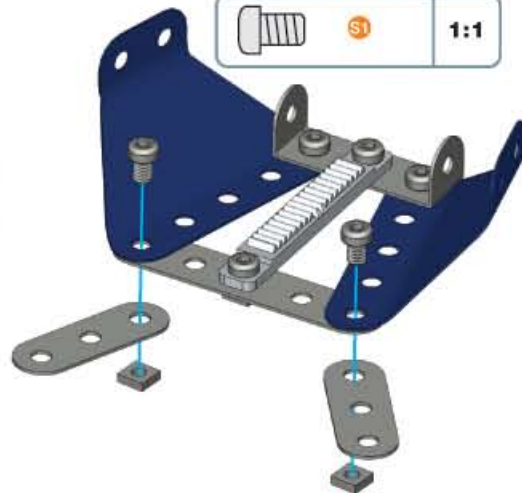

24

	x1
	x1
	x1
5.8mm 15/64"	x3
	x3

	1:1
--	------------

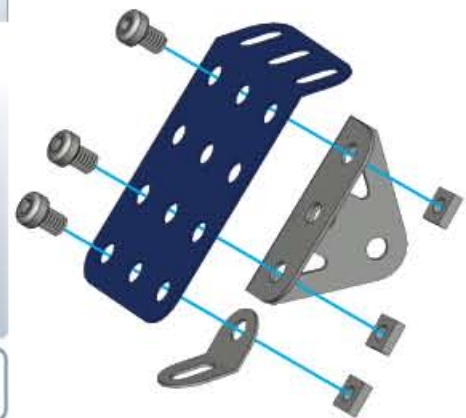

23+24+

25

x1  **x1**
5,8mm | 15/64"

x1  **x1**

1:1  **S1**

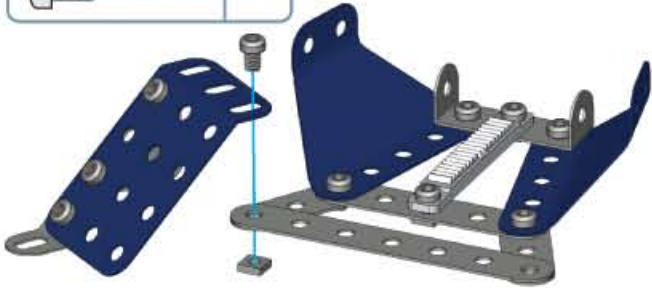



26

x1 

x1 

x1 

x3  **x3**
5,8mm | 15/64"

x3 

1:1  **S1**

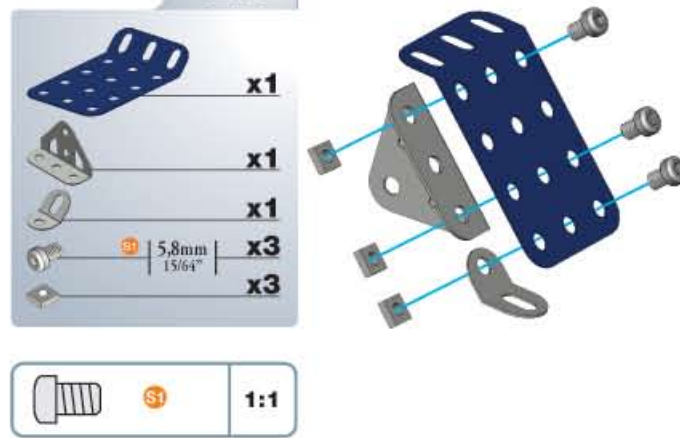

25+26+

27

x1  **x1**
5,8mm | 15/64"

x1 

1:1  **S1**

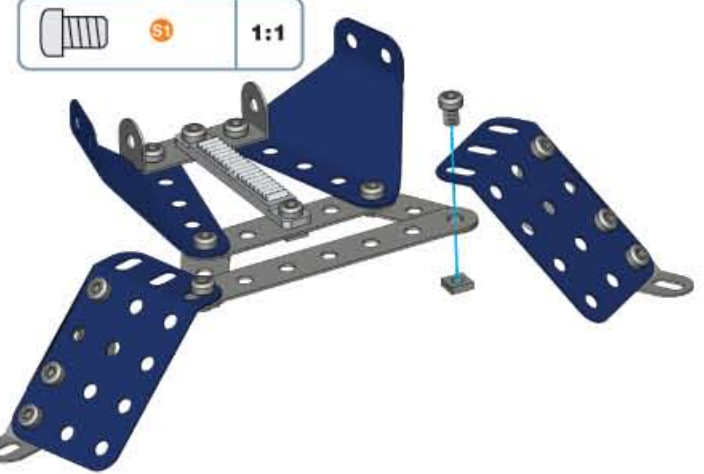

20+27+

28

x2  **x2**
5,8mm | 15/64"

x2 

1:1  **S1**

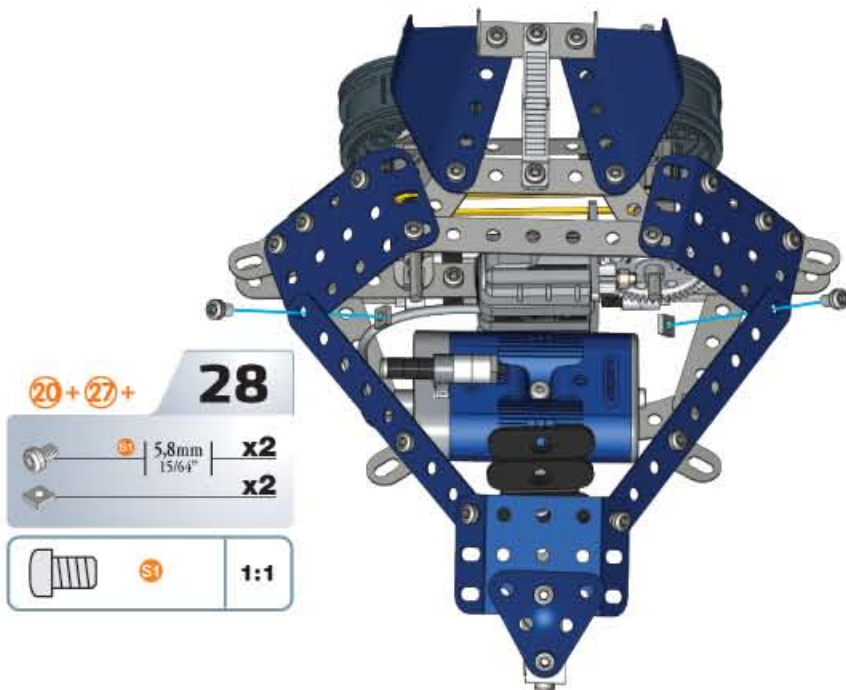

29

x1 

x1 

x2 

x1  **x1**
19mm | 3/4"

x1 

1:1  **S2**

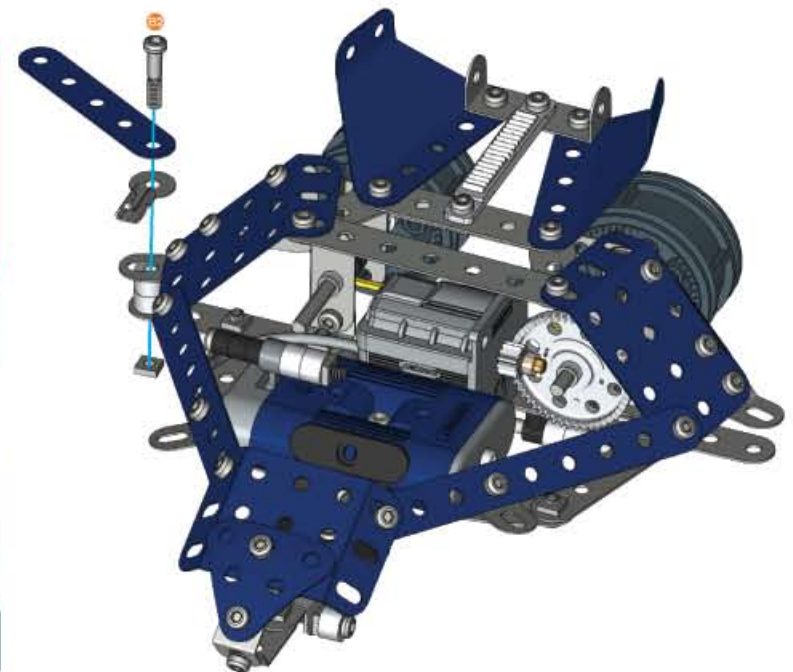
30

	x1
	x1
	x2
	x1
	x1

	1:1
--	-----

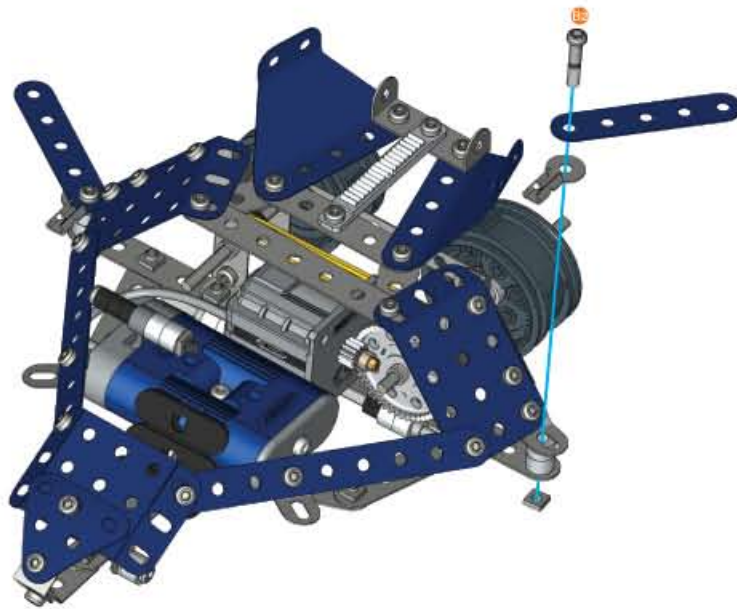

31

	x1
	x1
	x1
	x1

	1:1
--	-----



32

30 + 31 +

	x1
	x1
	x2
	x1

	1:1
	1:1

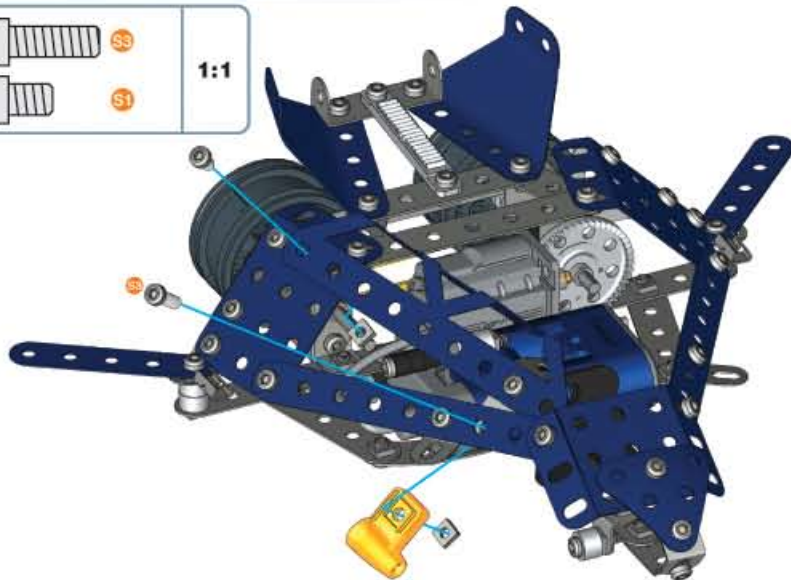

33

	x1
	x1
	x1
	x1

	1:1
--	-----

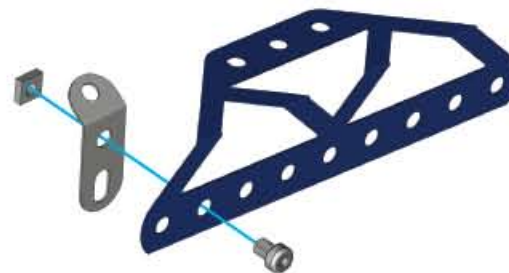

34

32 + 33 +

	x1
	x1
	x2
	x1

	1:1
	1:1

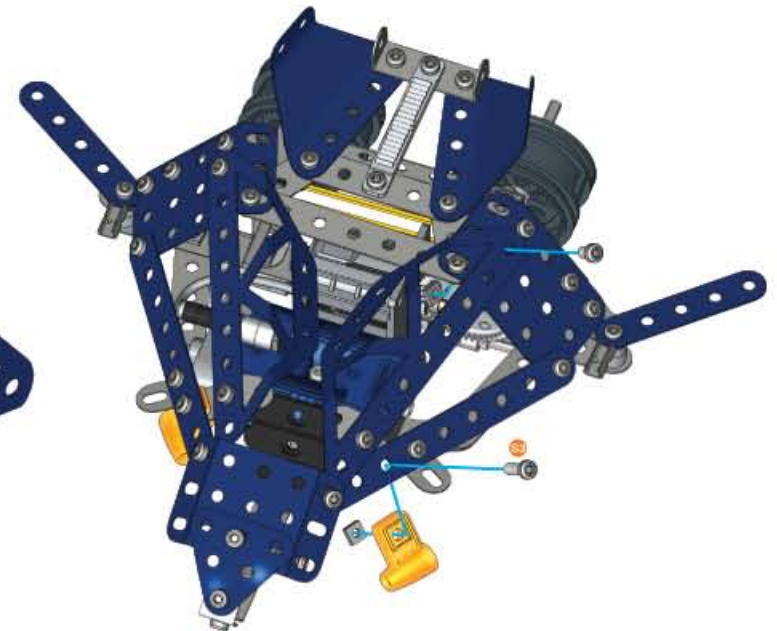

35

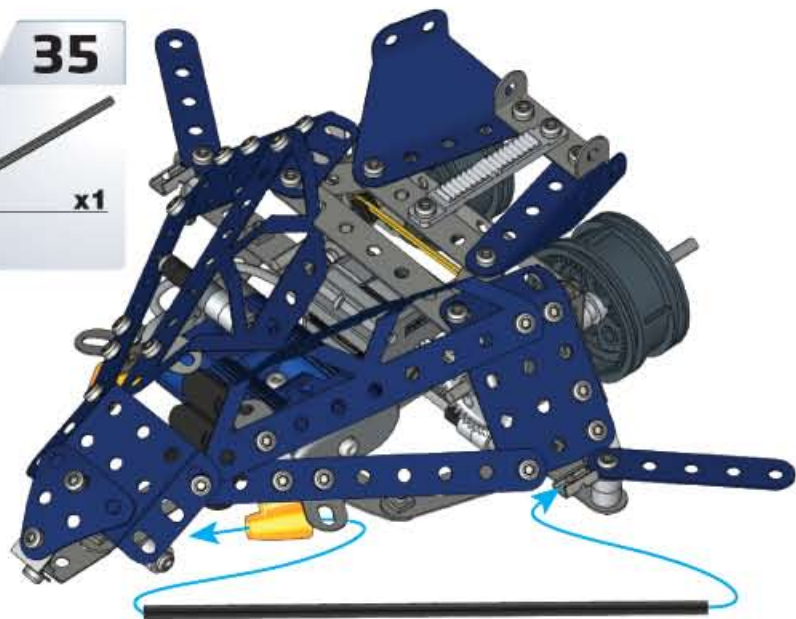

36

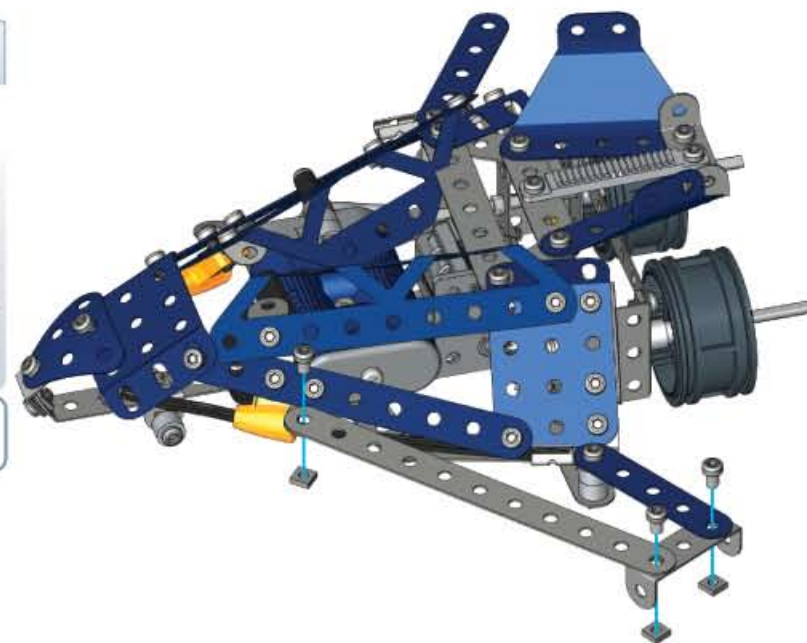

37

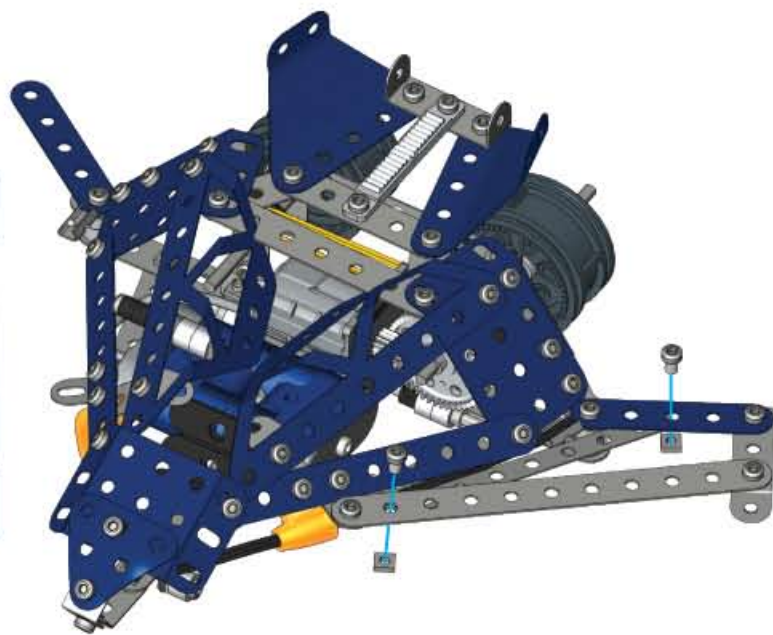

38

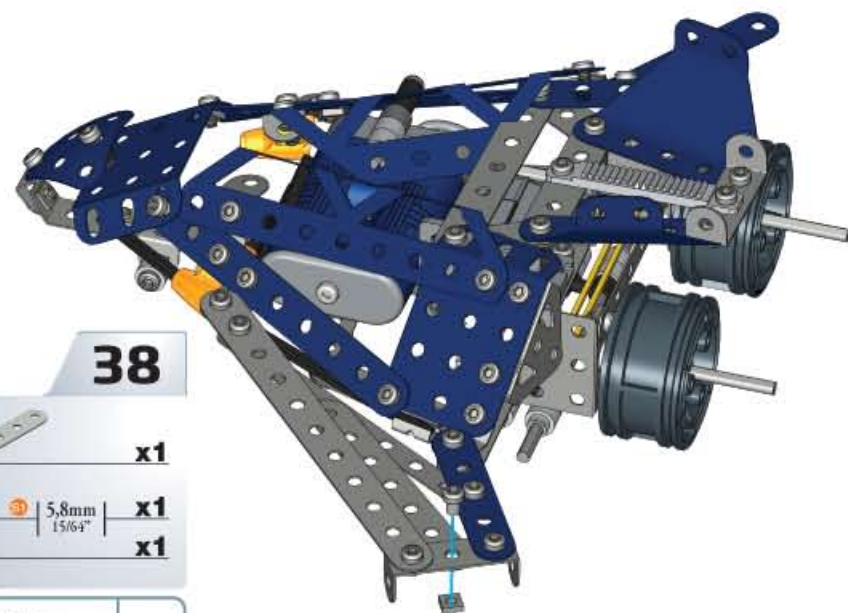

39

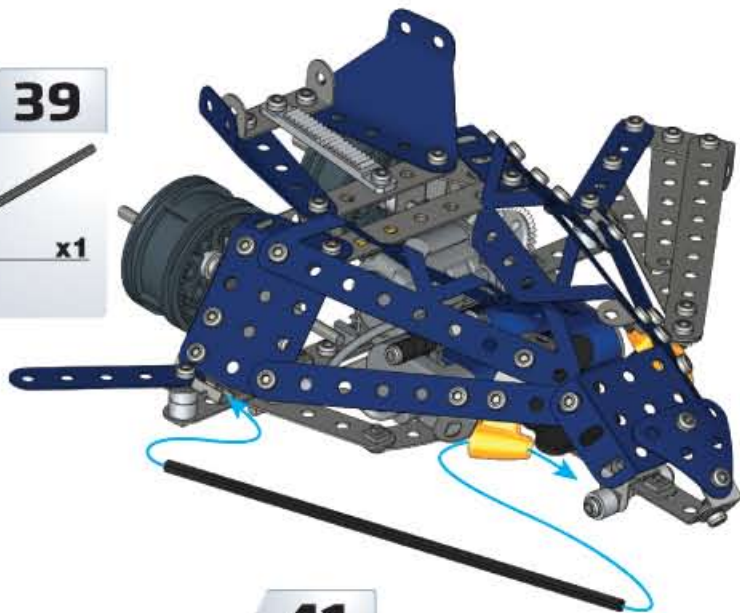

40

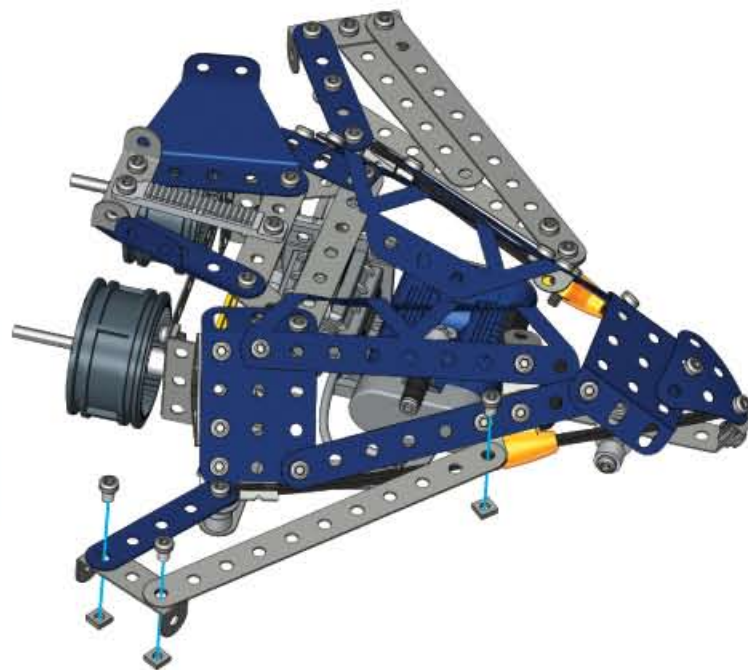
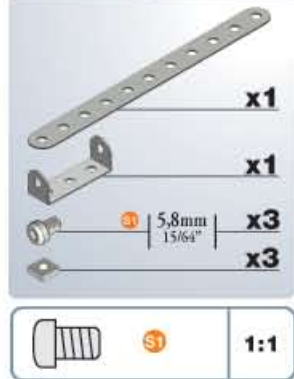

41

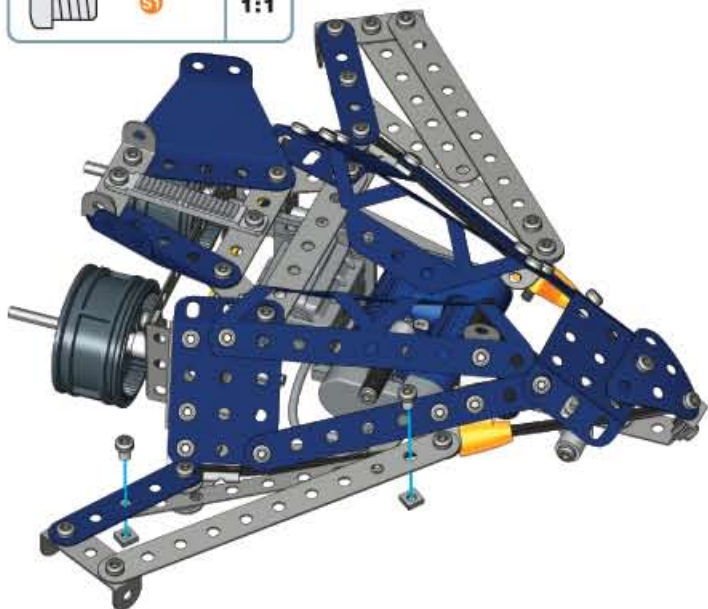

42

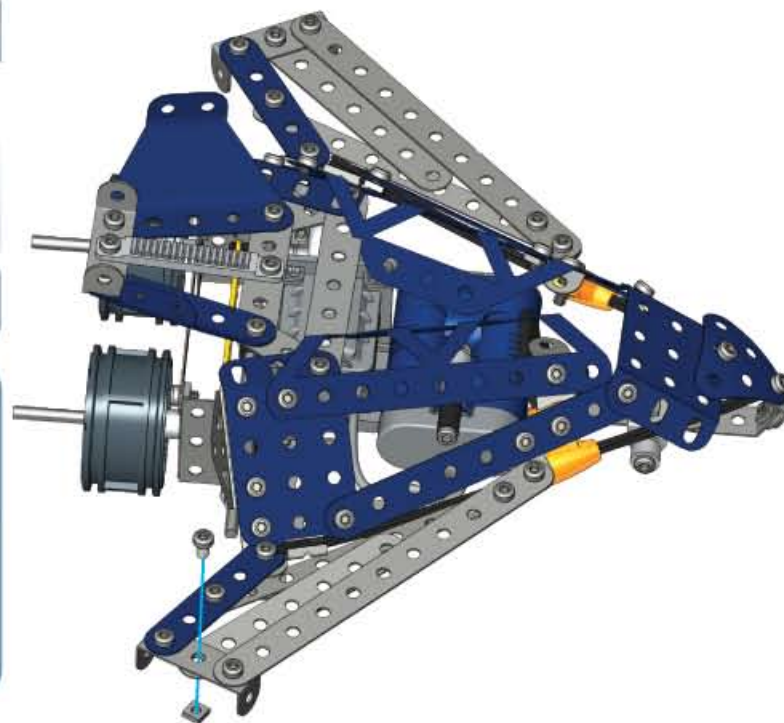
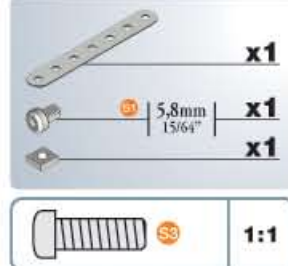



1

- x1
- x2
- 5,8mm x4
- 15/64" x4

- S1 1:1
- Scale 1 Escala 1 Mittakaava 1
- Echelle 1 Schaal 1 Målestok 1
- Maßstab 1 Escala 1 Μέτρο 1
- Scala 1 Skala 1 масштаб 1

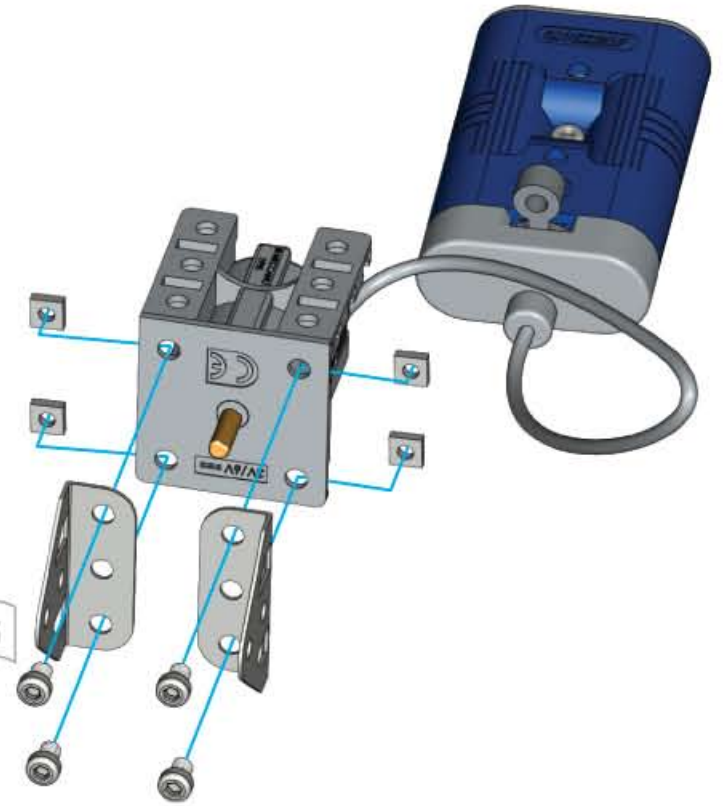

2

- x1
- x1

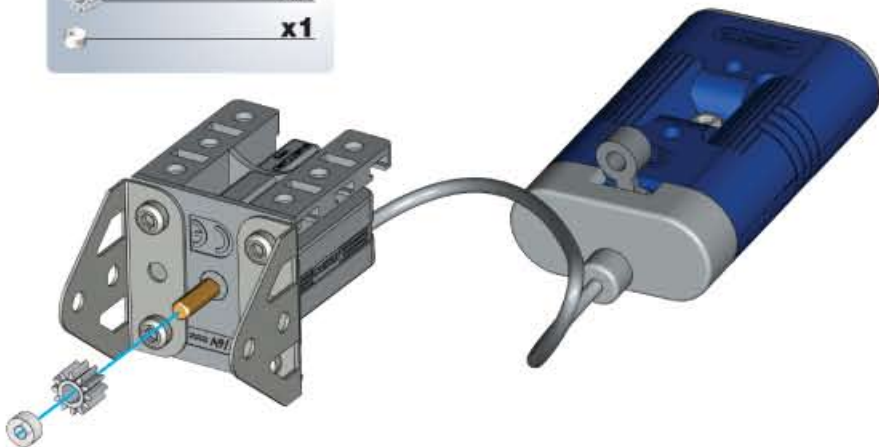

3

- x2
- x2
- x2
- 19mm x1
- 5,8mm x2
- 15/64" x3

- B2
- S1 1:1

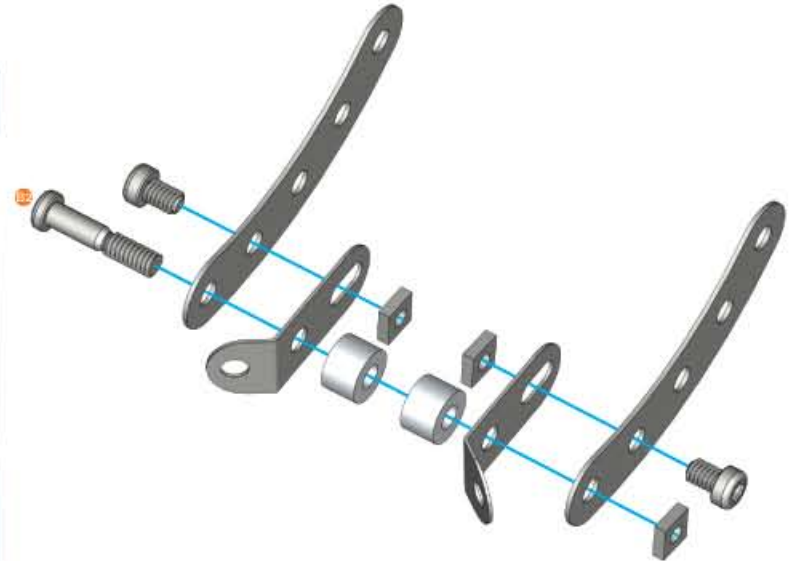

4

	x2
	x2
	x2

	1:1
--	------------

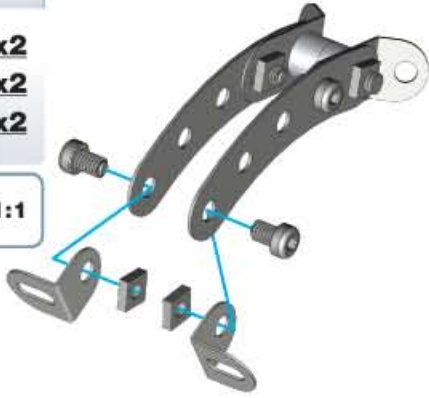

5

	x1
	x1
	x2
	x2

	1:1
--	------------

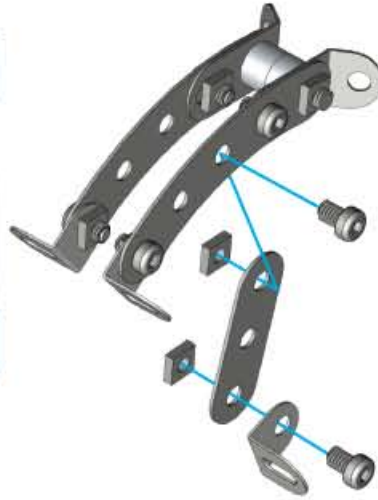

6

	x1
	x1
	x1

	1:1
--	------------



7

	x1
	x1
	x1

	1:1
--	------------



8

	x1
	x1
	x2
	x3

	1:1

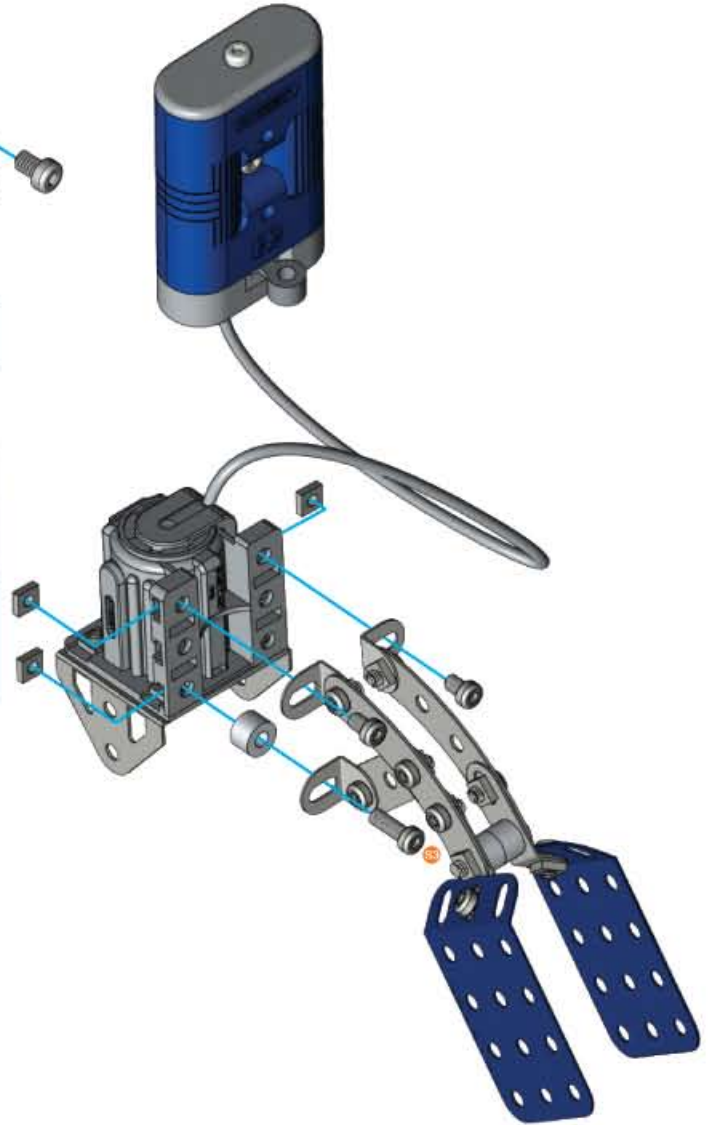



9

- 65mm | 2 1/2" | **x1**
- x1**
- x2**
- x2**



11

- x2**
- 5,8mm | 15/64" | **x2**
- x2**



⑨ + ⑪ +

12

- 5,8mm | 15/64" | **x2**
- x2**
- x2**



10

- x1**
- x2**
- x3**
- x1**
- 38,1mm | 1 1/2" | **x1**
- x1**

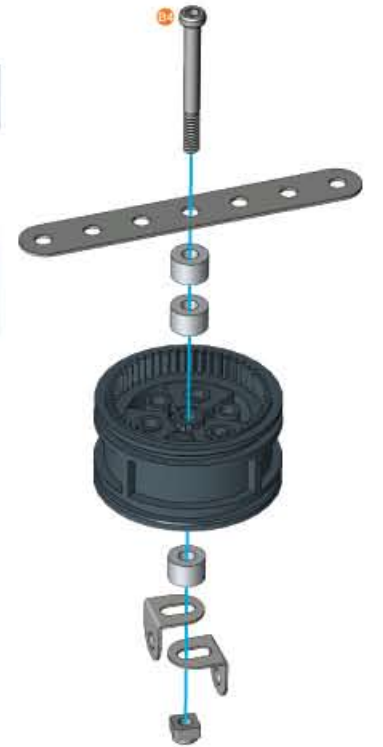
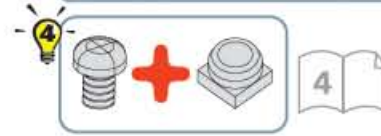
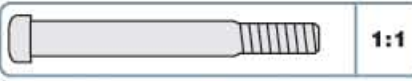



13

	x1		x2
			x2
			x2

		1:1
--	--	-----

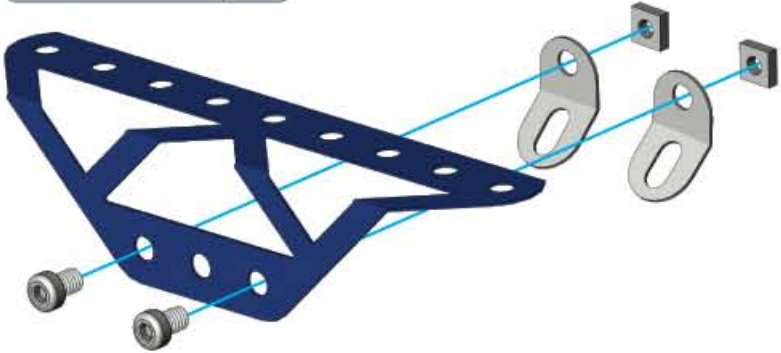

14

	x1		x2
			x2

		1:1
--	--	-----

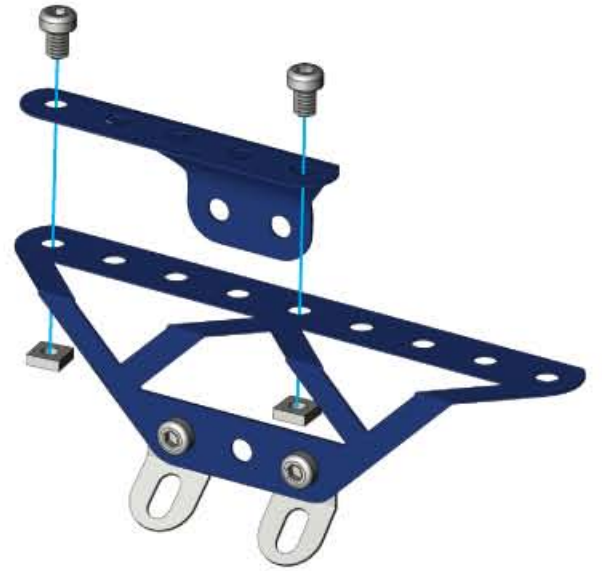

15

	x1		x1
			x1
			x3
			x3

		1:1
--	--	-----

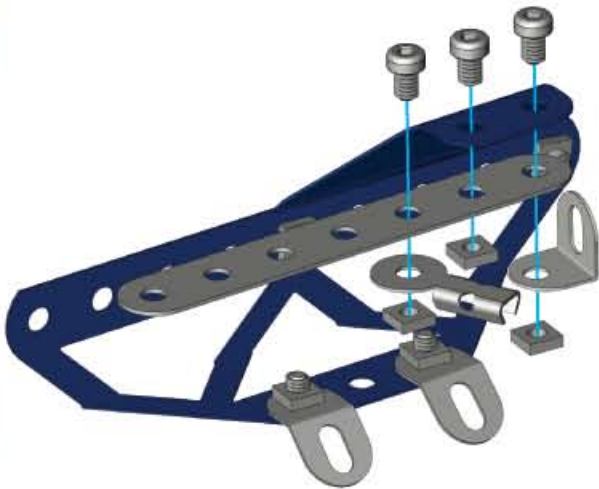



16

	x1		x2
			x2

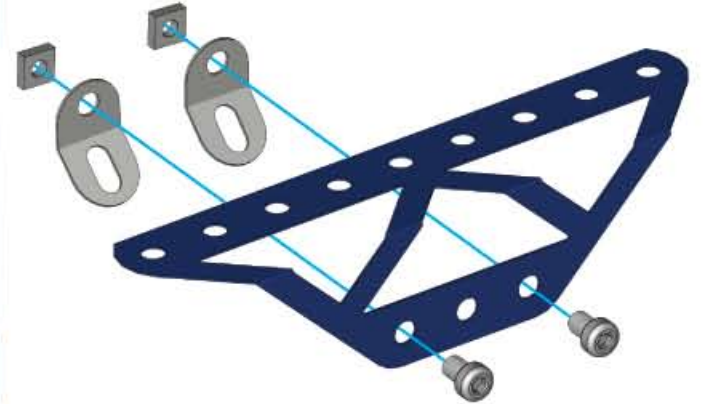
		1:1
--	--	-----



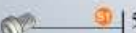
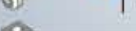

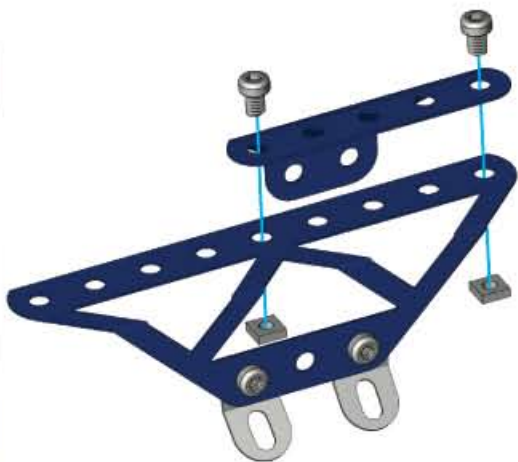

17

-  **x1**
-  **x2**
-  **x2**
-  **1:1**

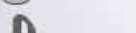
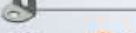

18

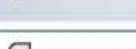
-  **x1**
-  **x1**
-  **x1**
-  **x3**
-  **x3**
-  **1:1**

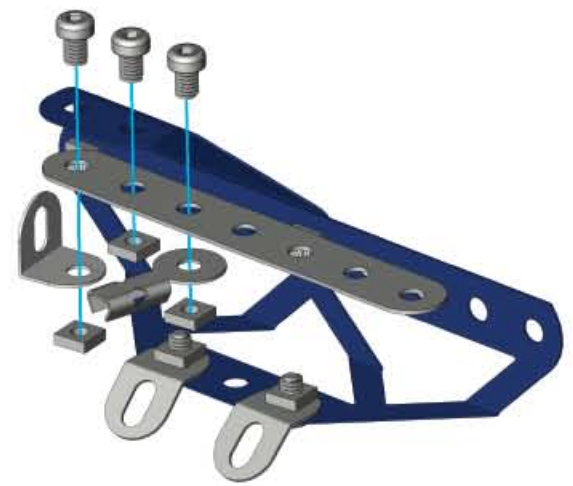



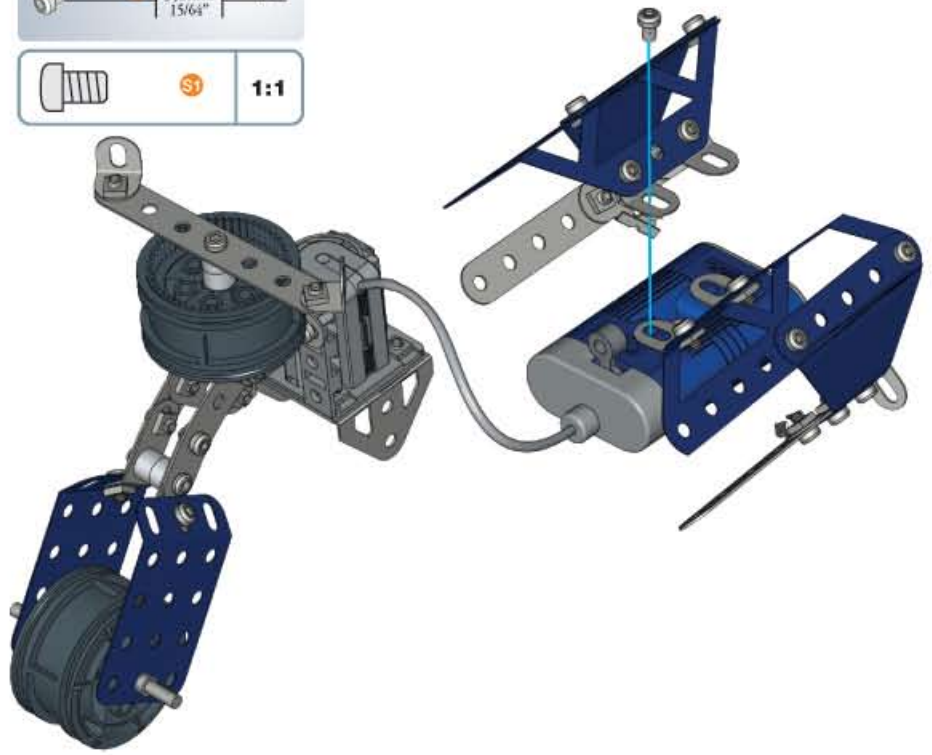

12 + 15 + 18 + 19

-  **x1**
-  **1:1**



20

-  **x1**
-  **x1**
-  **x1**
-  **1:1**

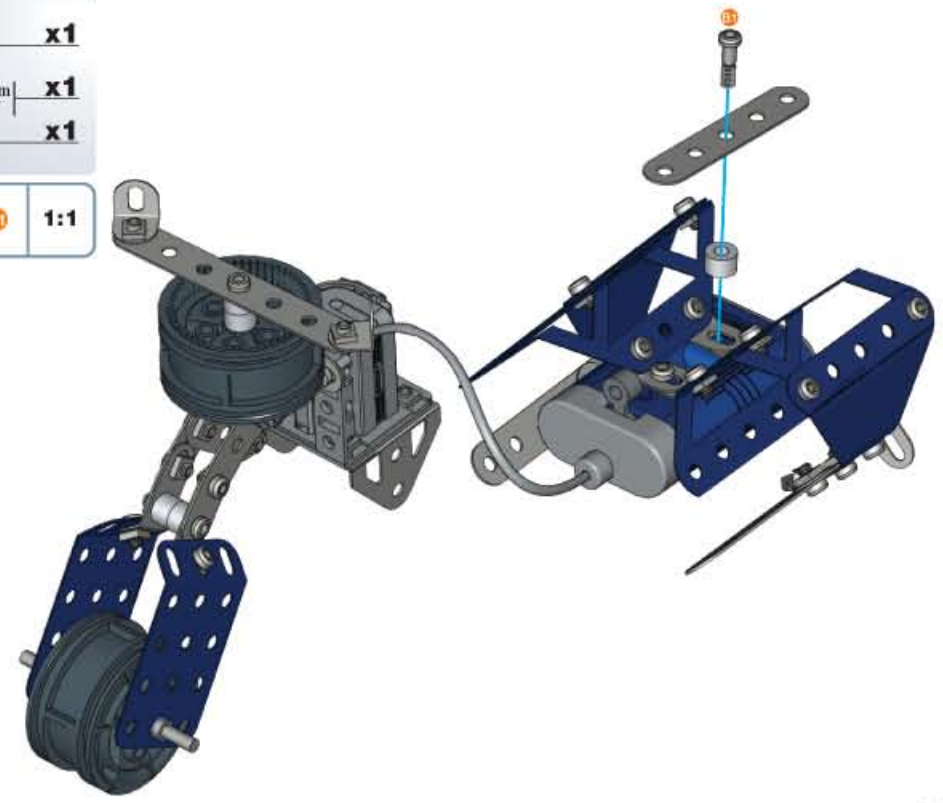

21

5,8mm | x2
15/64" | x2

1:1



22

x1
x4
x1
38,1mm | x1
1 1/2" | x1

1:1

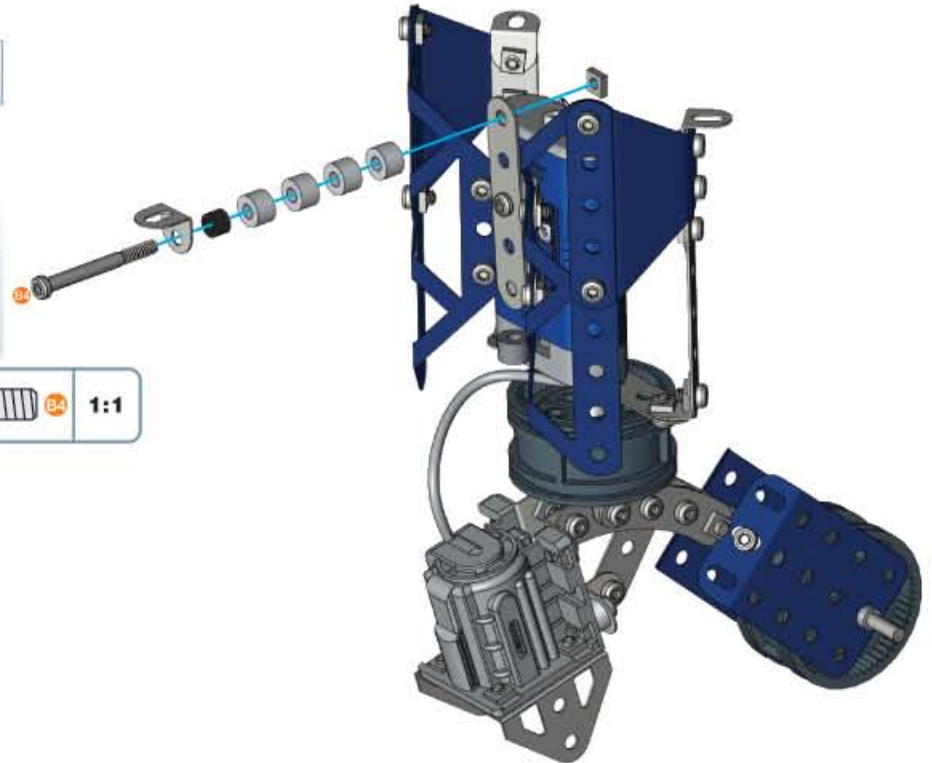

23

x1
x1
12mm | x1
1/2" | x1

1:1

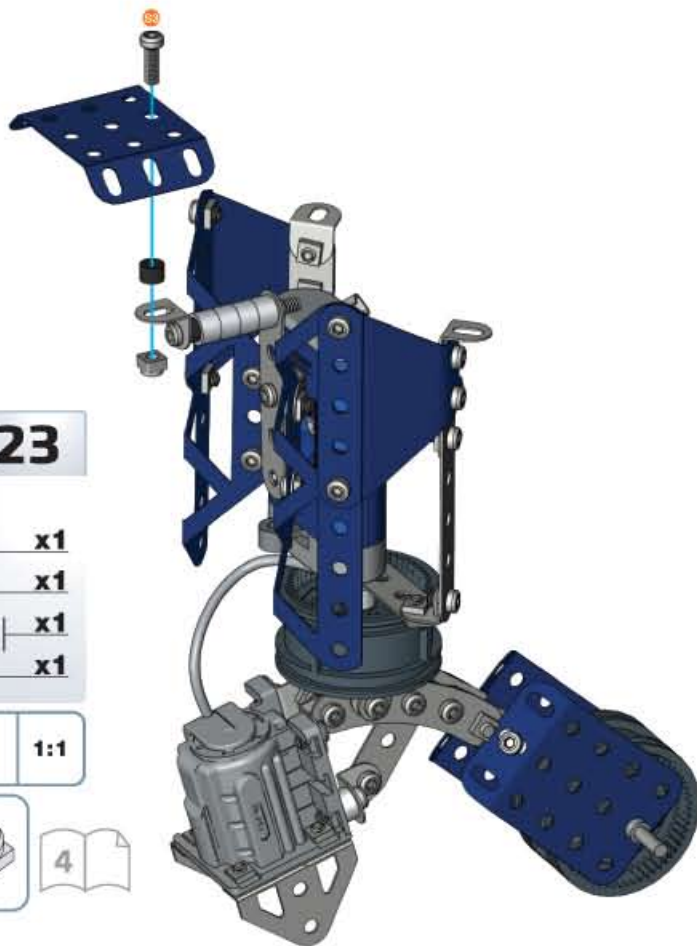

24

x1
x1
9,5mm | x1
3/8" | x1

1:1



25

	x1
	x2
	x2
	x1
	x2

	S3	1:1
	S1	1:1

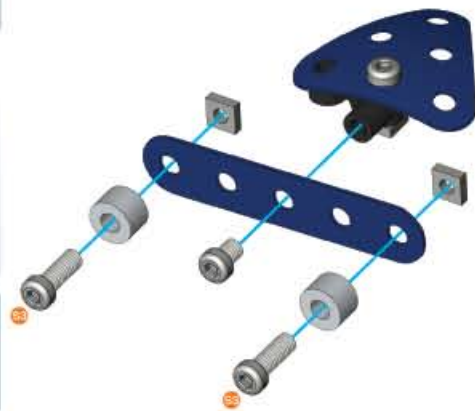
**23+25+ 26**

	S3	5.8mm	x1
	S1	15/64"	x1
	S1		1:1

**27**

	x1		
	x2		
	S3	5.8mm	x2
	S1	15/64"	x2

	S1	1:1
--	-----------	------------

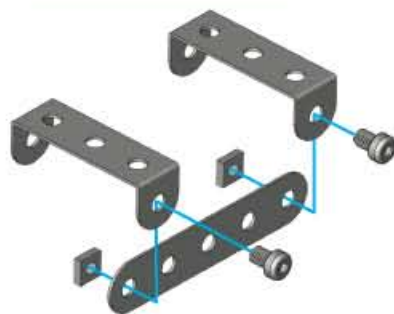
**28**

	x1		
	S3	5.8mm	x2
	S1	15/64"	x2

	S1	1:1
--	-----------	------------

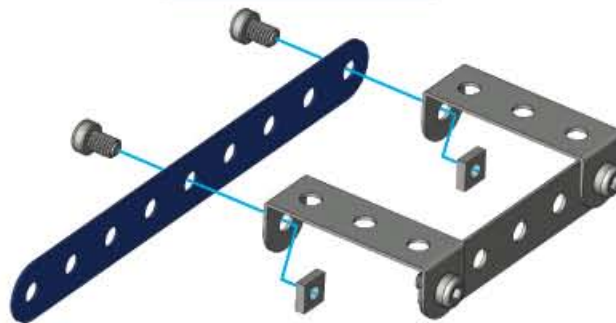
**29**

	x1		x1
	S3	5.8mm	x1
	S1	15/64"	x1

	S1	1:1
--	-----------	------------



30

	x2
	x2
	x2
	x1

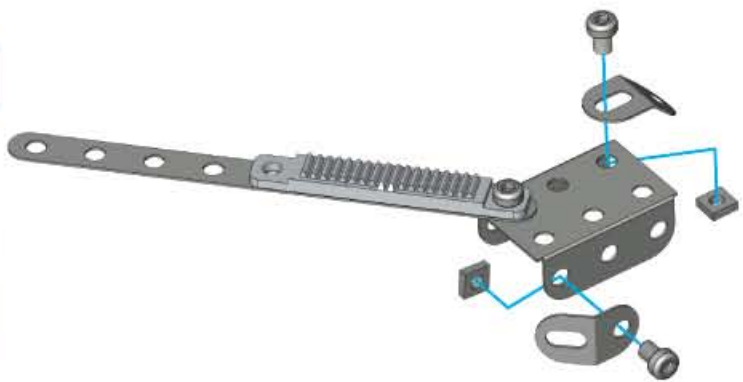

28 + 30 + 31

31

	x1
	x1
	x2
	x3
	x1
	x1

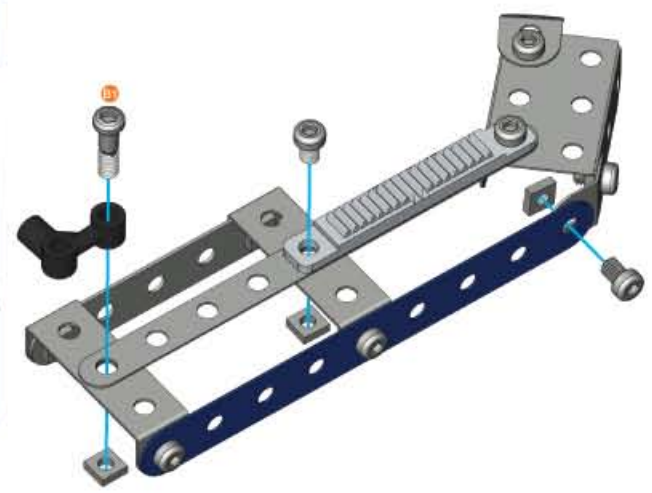

26 + 31 + 32

32

	x1
	x1
	x1
	x1
	x1
	x1

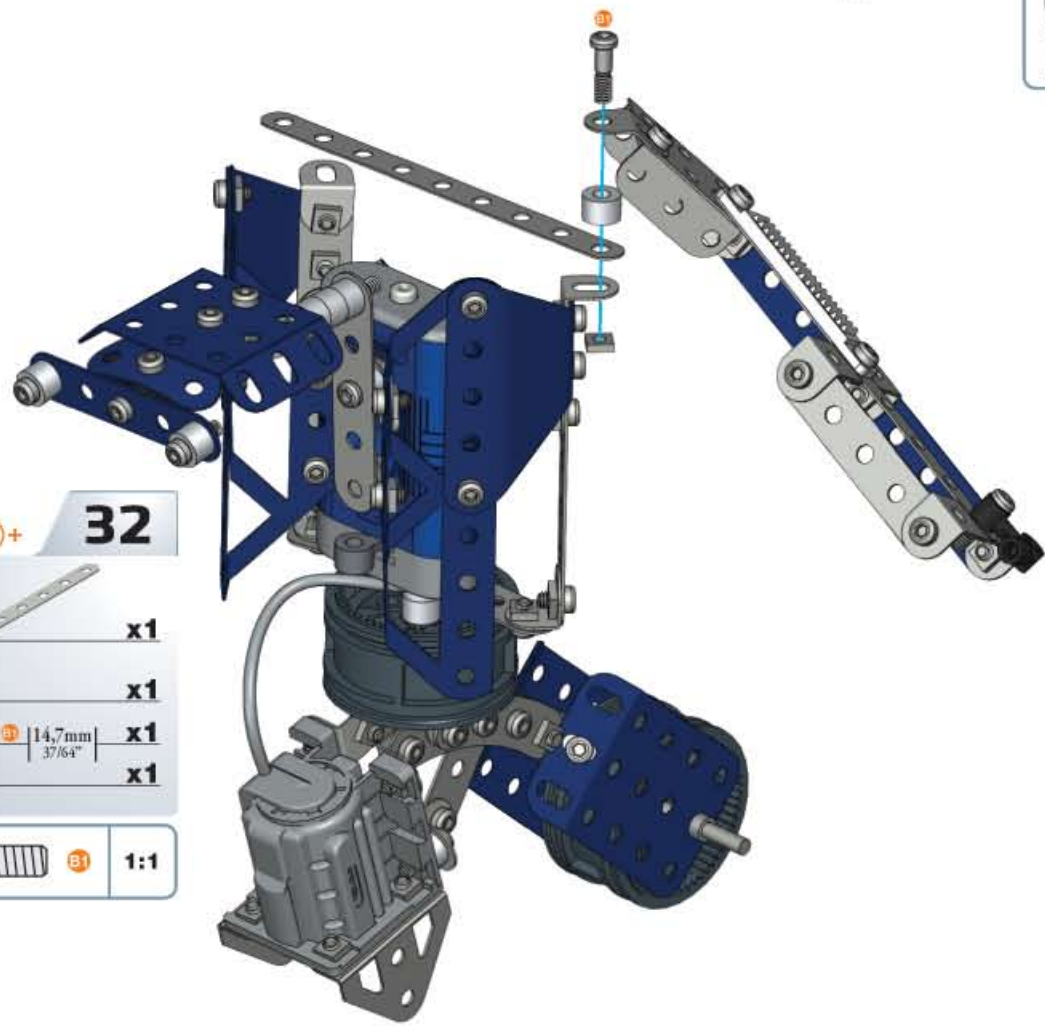

33

	x1
	x1
	x1
	x2
	x2
	x1

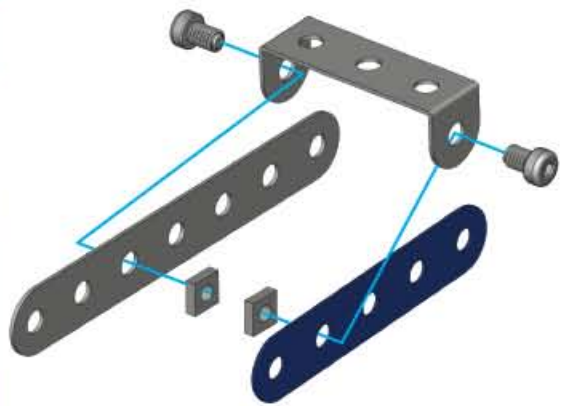

34

	x1
	x1
	x1
	x4
	x4

	S1	1:1
--	----	-----

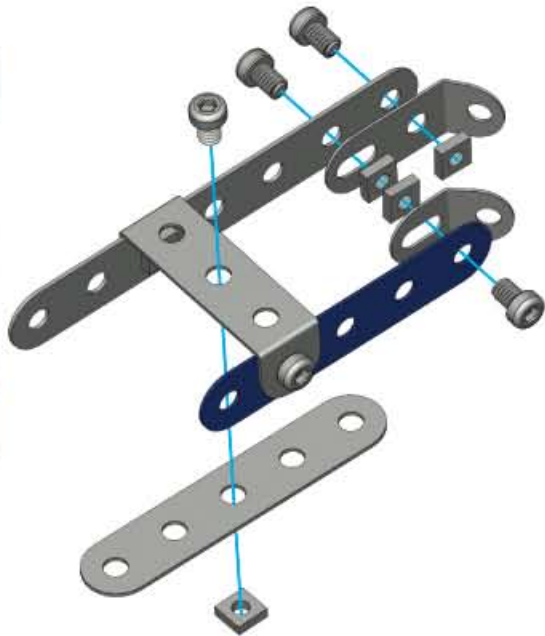

35

	x1		
	S1	5,8mm	x1
	15/64"	x1	

	S1	1:1
--	----	-----



36

	x1		
	x1		
	S1	12mm	x1
	1/2"	x1	

	S1	1:1
--	----	-----

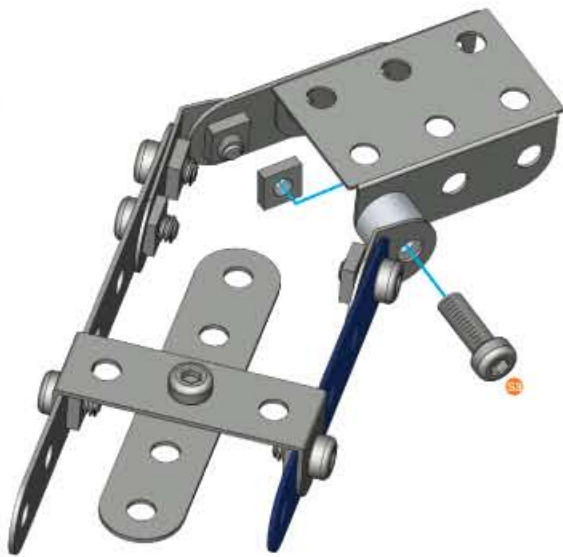



37

	x1		
	S1	5,8mm	x3
	15/64"	x3	

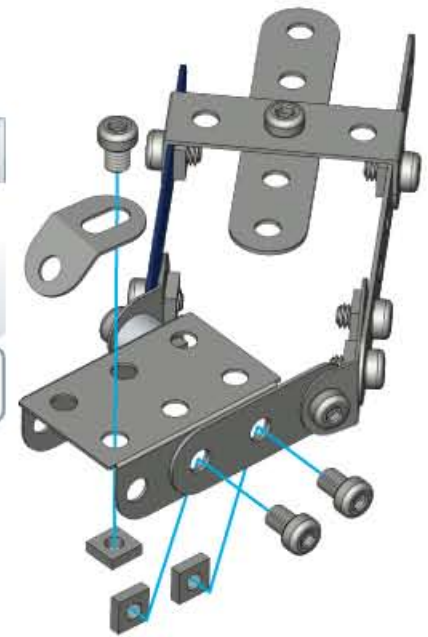
	S1	1:1
--	----	-----



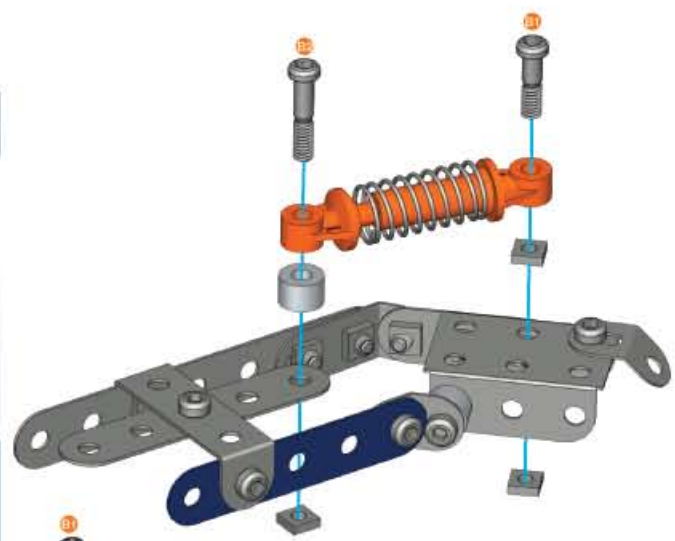

38

-  **x1**
 -  **x1**
 -  **19mm** **x1**
3/4"
 -  **14,7mm** **x1**
37/64"
 -  **x3**
- | | | |
|---|-----------|------------|
|  | 32 | 1:1 |
|  | B1 | |



39

-  **x1**
 -  **x1**
 -  **14,7mm** **x1**
37/64"
 -  **x1**
- | | | |
|---|-----------|------------|
|  | B1 | 1:1 |
|---|-----------|------------|

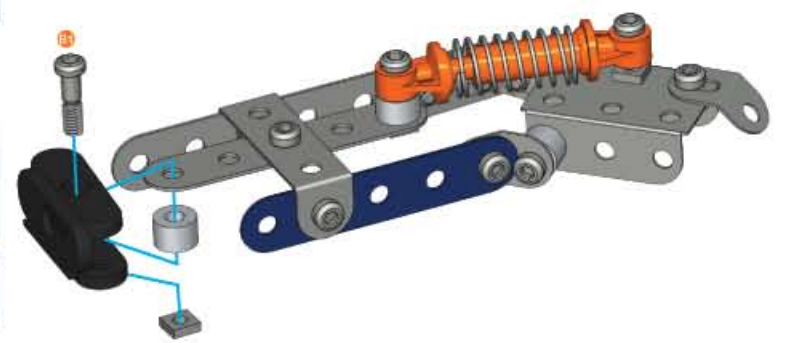



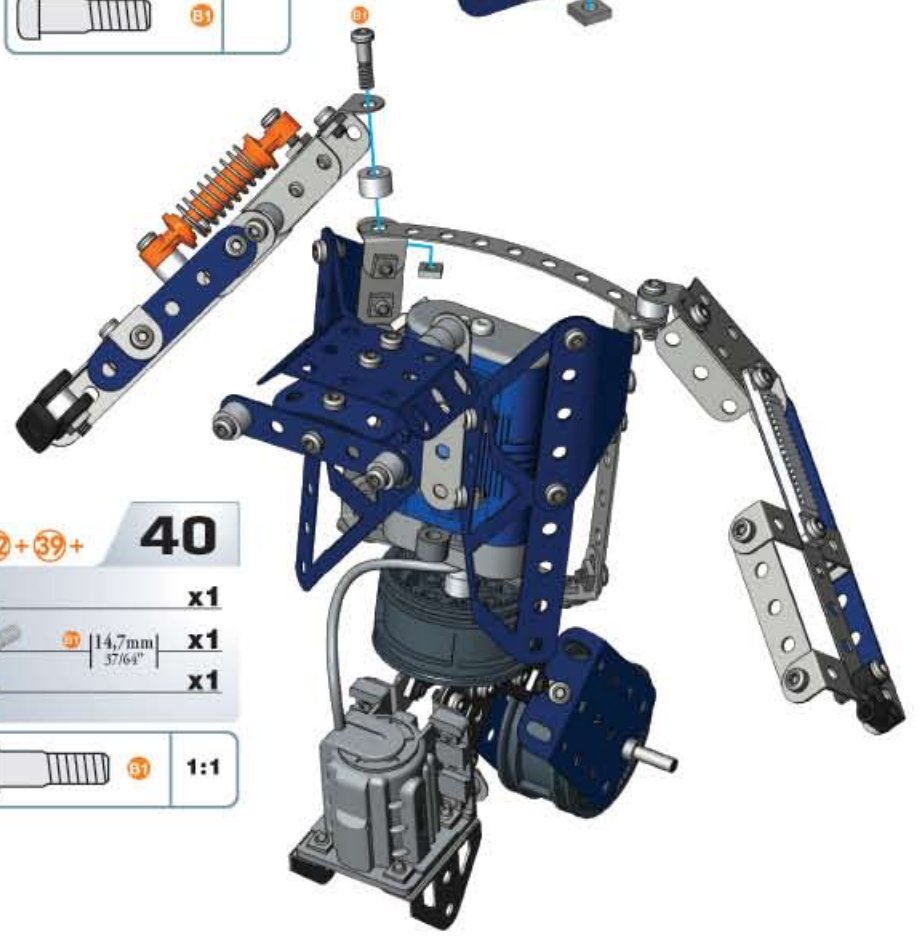

40

- 32 + 39 +**
-  **x1**
 -  **14,7mm** **x1**
37/64"
 -  **x1**
- | | | |
|--|-----------|------------|
|  | B1 | 1:1 |
|--|-----------|------------|



41

-  **x1**
 -  **14,7mm** **x1**
37/64"
 -  **x1**
- | | | |
|---|-----------|------------|
|  | B1 | 1:1 |
|---|-----------|------------|

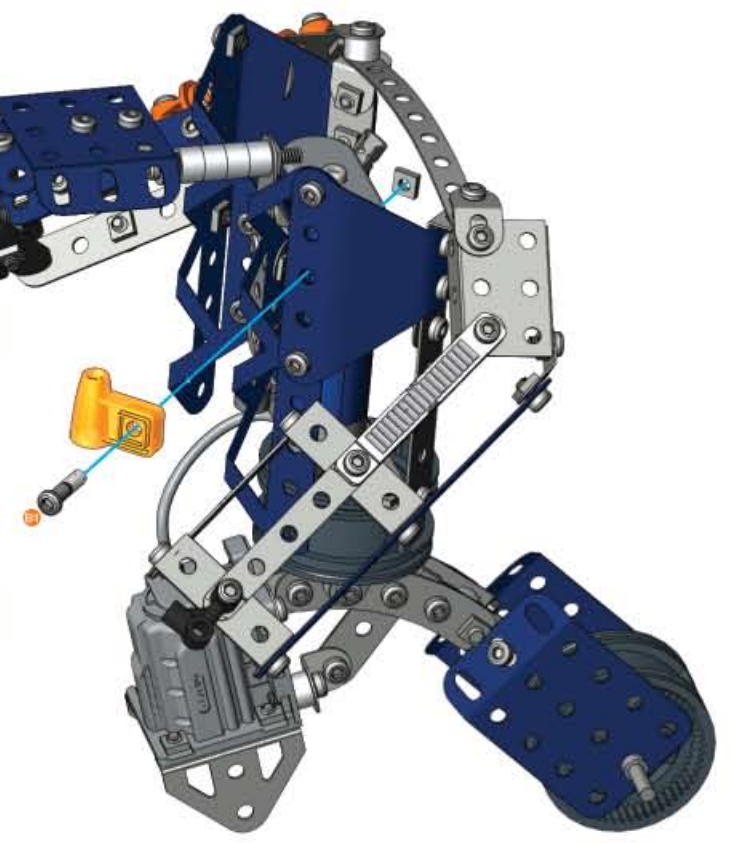

42



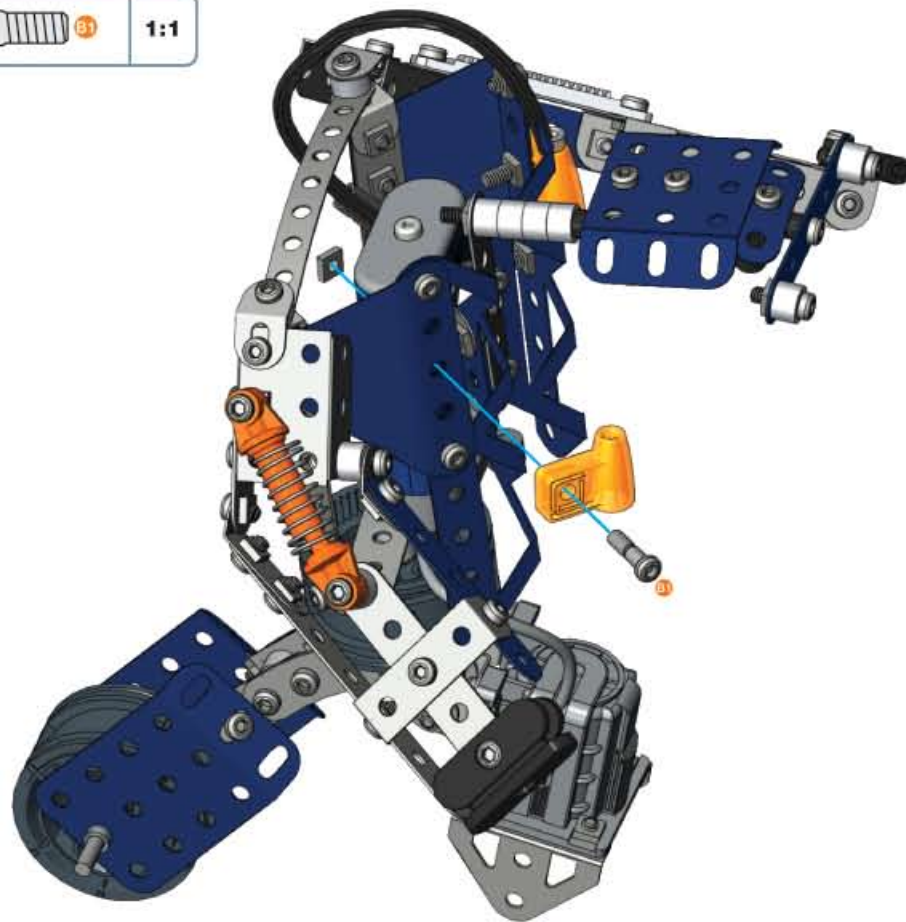
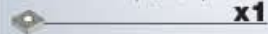

43

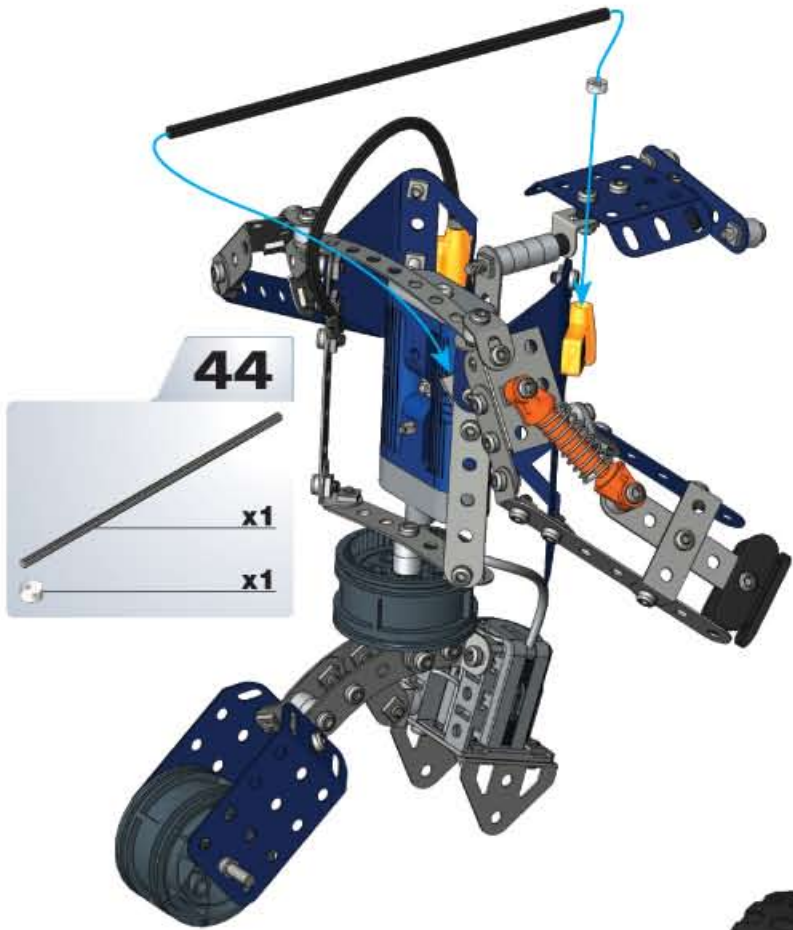









44

-  x1
-  x1

- 45**
-  x4
 -  x2



- 44 + 45 +**
- 46**
-  x1
 -  x1
 -  x2
 -  x2
 -  x5
 -  x2
 -  x2

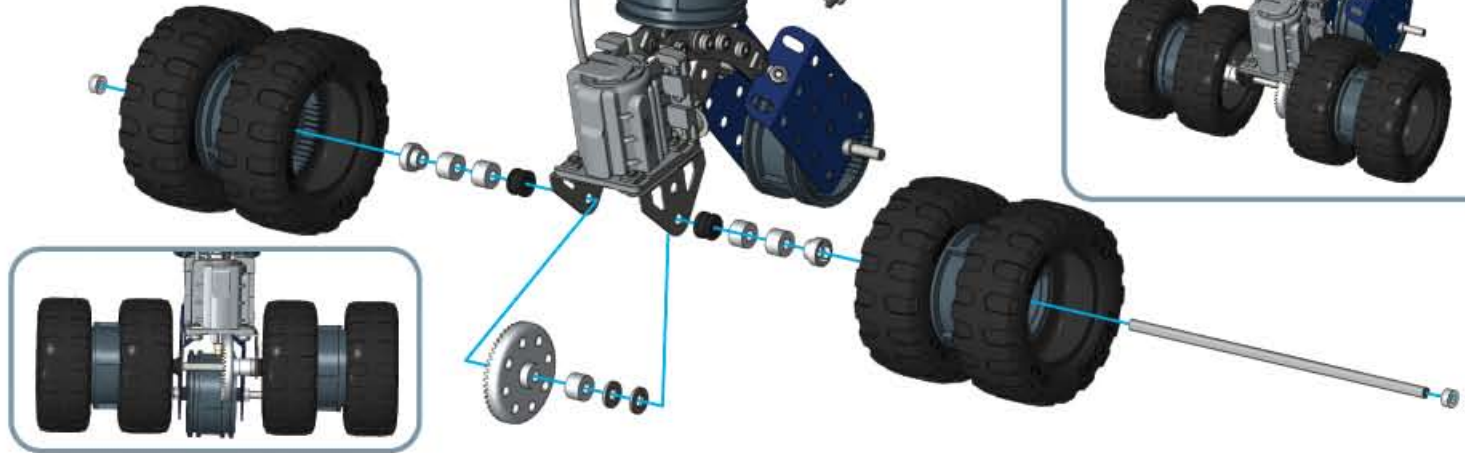

1:1

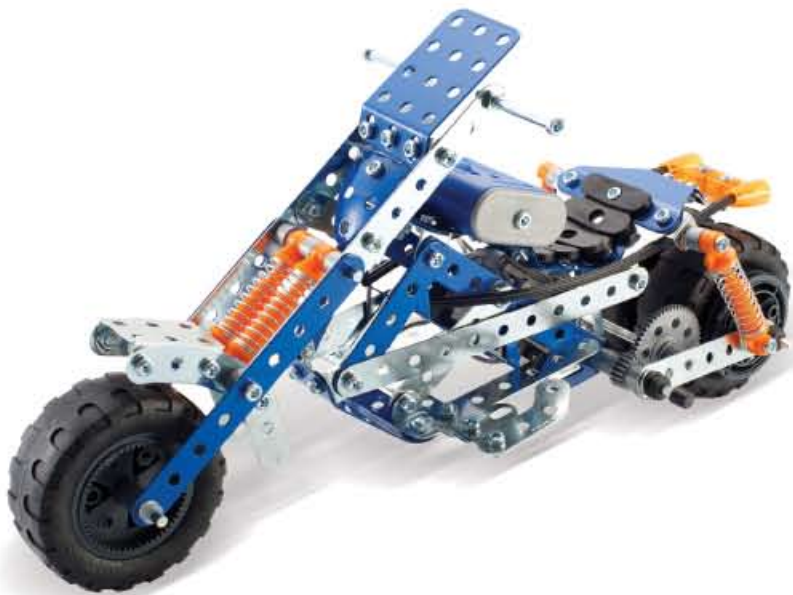

1

-  x1
-  x2
-  5,8mm | x4
-  15/64" | x4

	S1	1:1	
	Scale 1	Escala 1	Mittakaava 1
	Echelle 1	Schaal 1	Målestok 1
	Maßstab 1	Escala 1	Κλίμακα 1
	Scala 1	Skala 1	масштаб 1

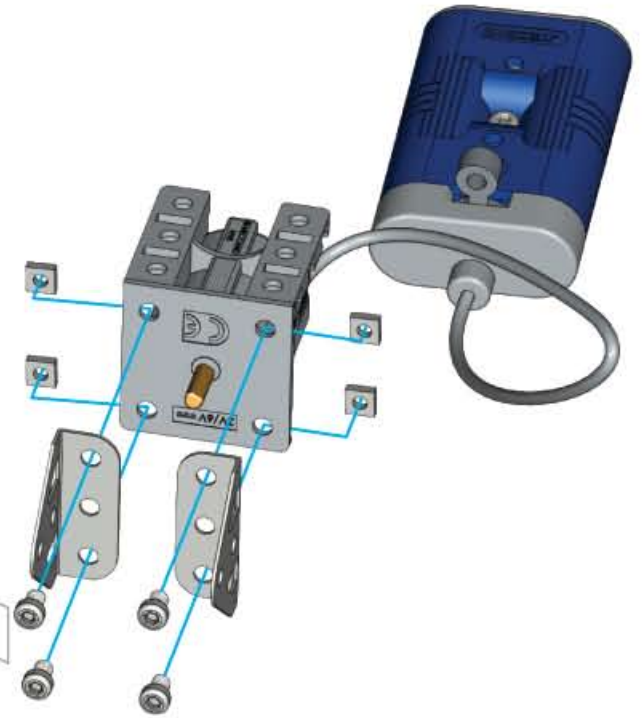

2

-  x1
-  x1

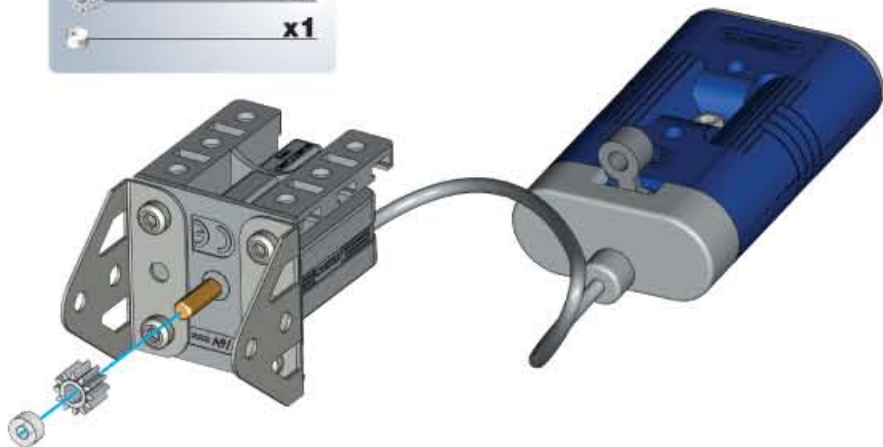

3

-  x1
-  x2
-  5,8mm | x2
-  15/64" | x2

	S1	1:1
---	----	-----

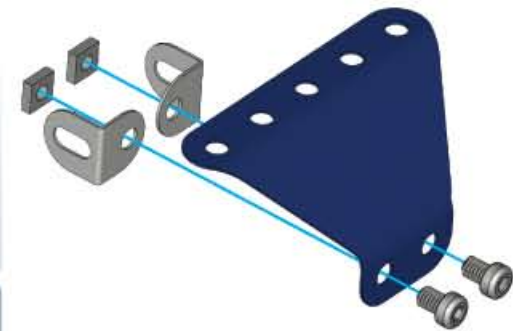

4

	x1
	x2
	x2
	x2
	x4
	x4
	1:1

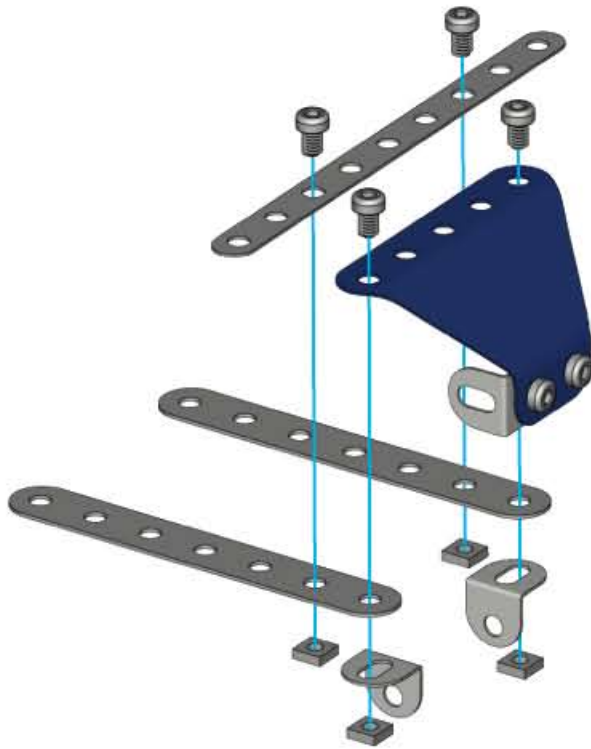

5

	x1
	x1
	x2
	x2
	1:1

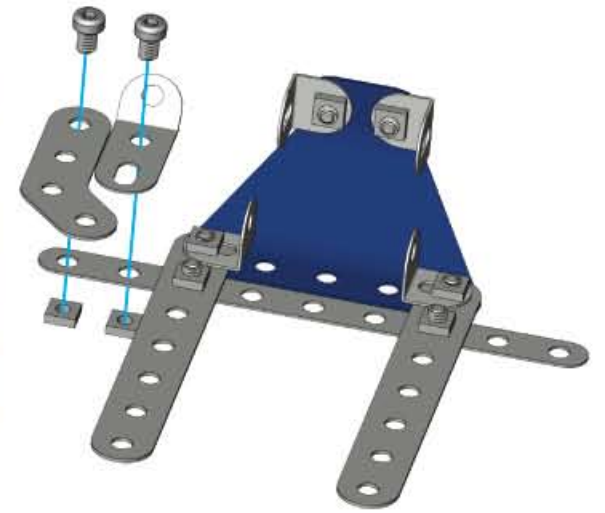

6

	x2
	x2
	x1
	x2
	x2
	1:1

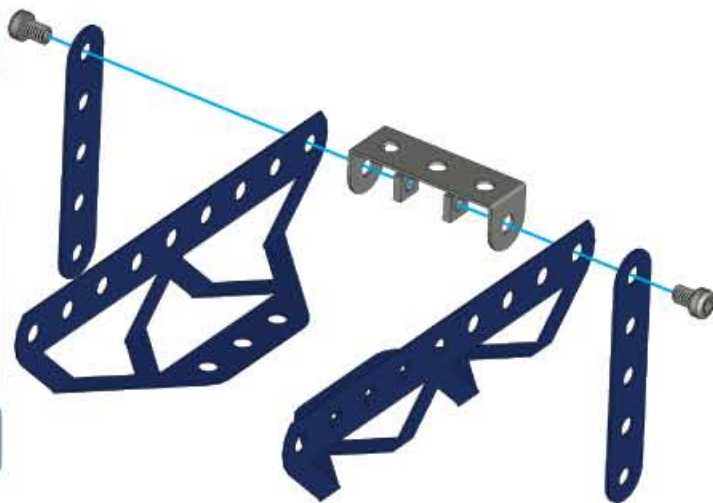

5+6+7

	x1
	x2
	x2
	1:1

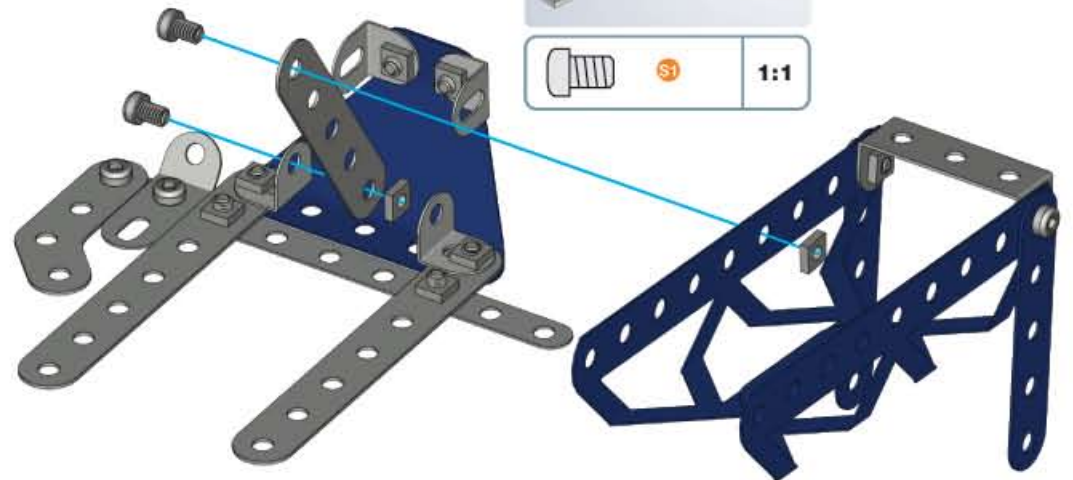

8

	x1
	x1
	x2
	x2
	1:1

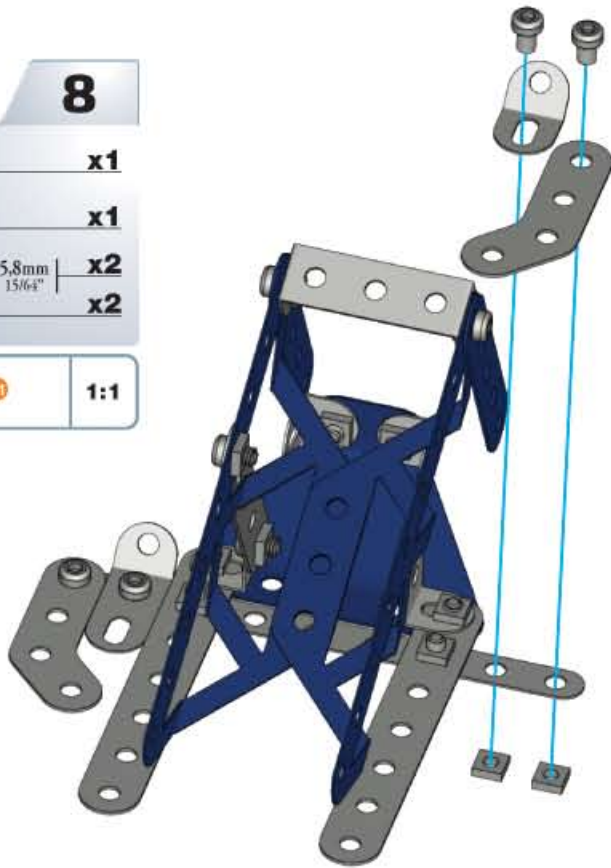

9

	x1
	x2
	x2
	x2
	1:1

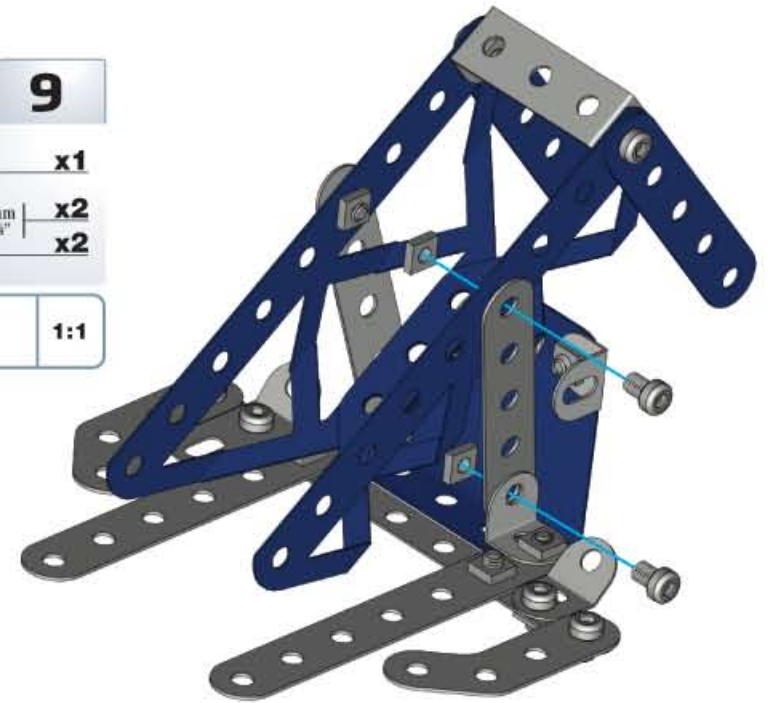

10

	x1
	x2
	x2
	x2
	1:1

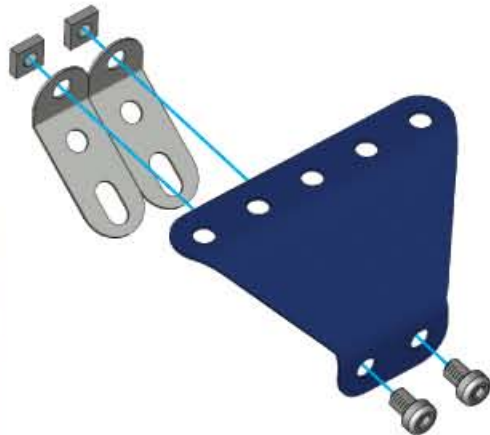

11

	x2
	x2
	x2
	x2
	1:1

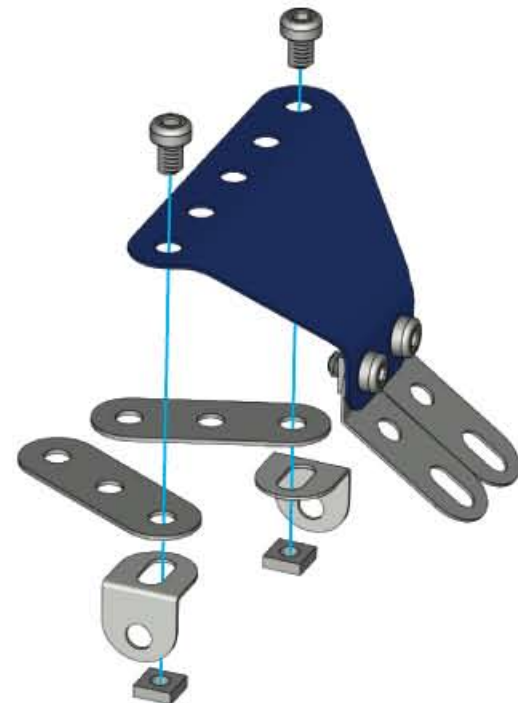

12

	x1
	x2
	x2
	x2
	1:1

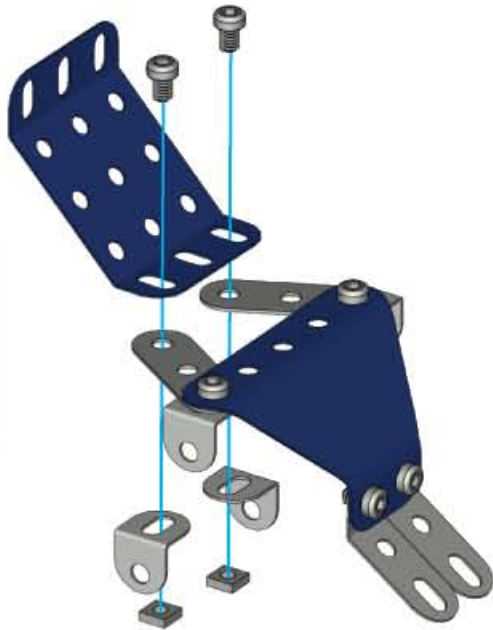

②+ **14**

	x1
	x2
	1:1

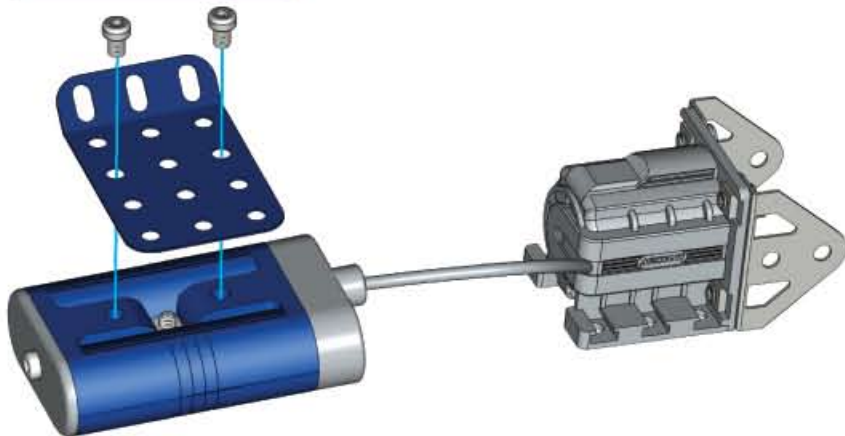

13

	x1
	x2
	x2
	1:1

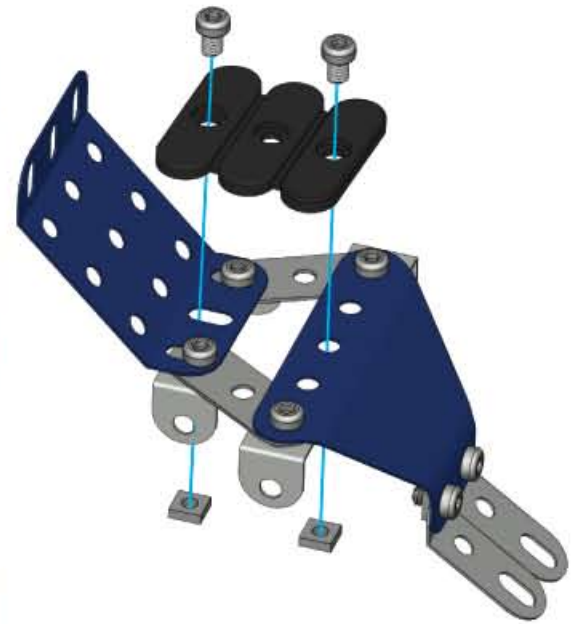



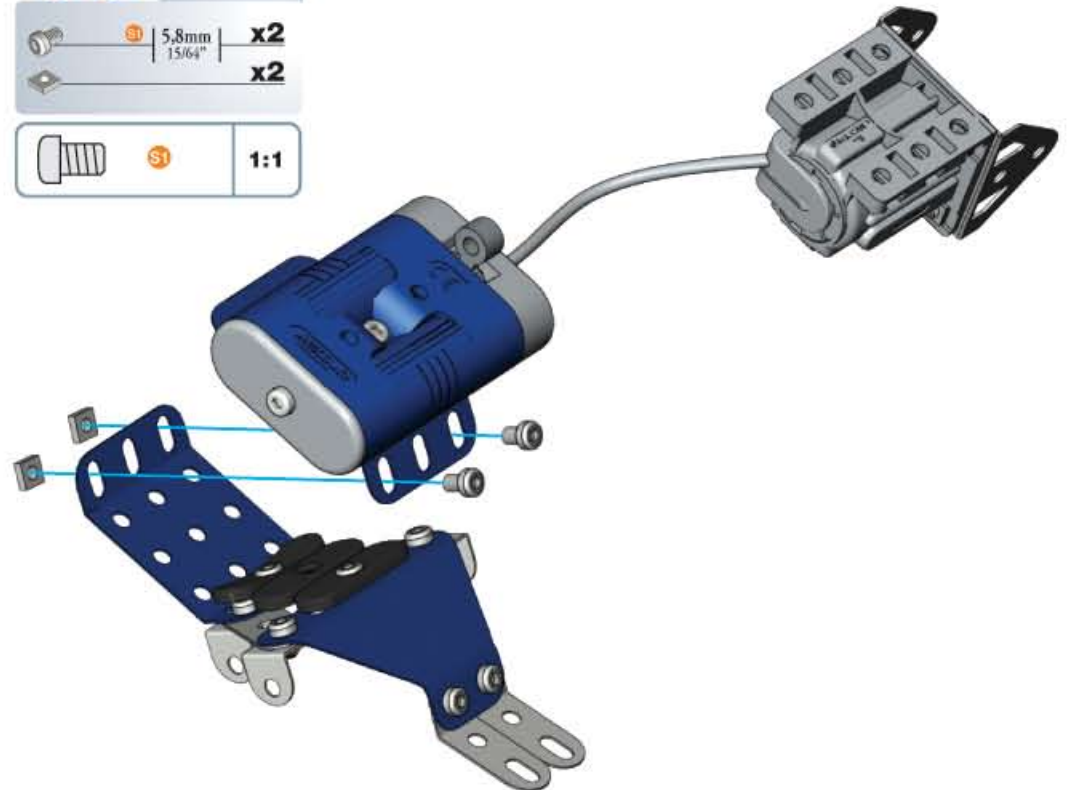

⑬+⑭+ **15**

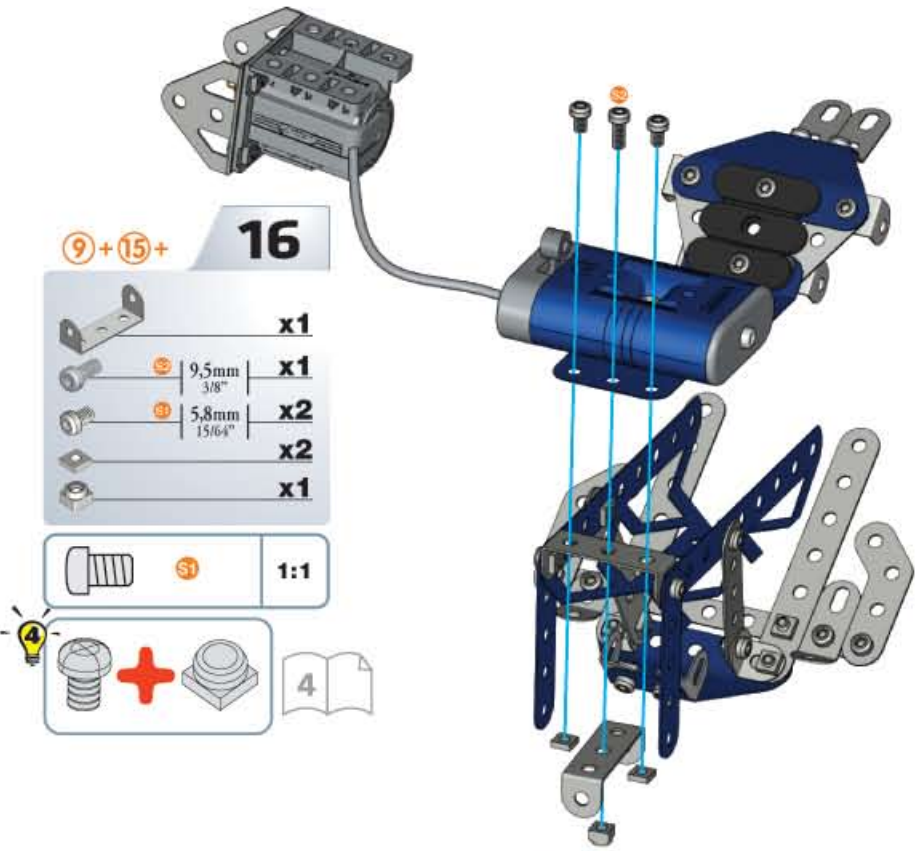
	x2
	x2
	1:1









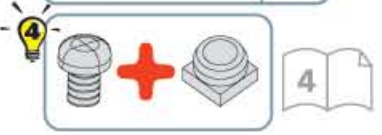

9 + 15 + **16**

-  **x1**
-  9,5mm **x1**
3/8"
-  5,8mm **x2**
15/64"
-  **x2**
-  **x1**

-  **S1** **1:1**



18

-  **x1**
-  **x1**
-  12mm **x1**
1/2"
-  5,8mm **x1**
15/64"
-  **x2**

-  **S1** **1:1**

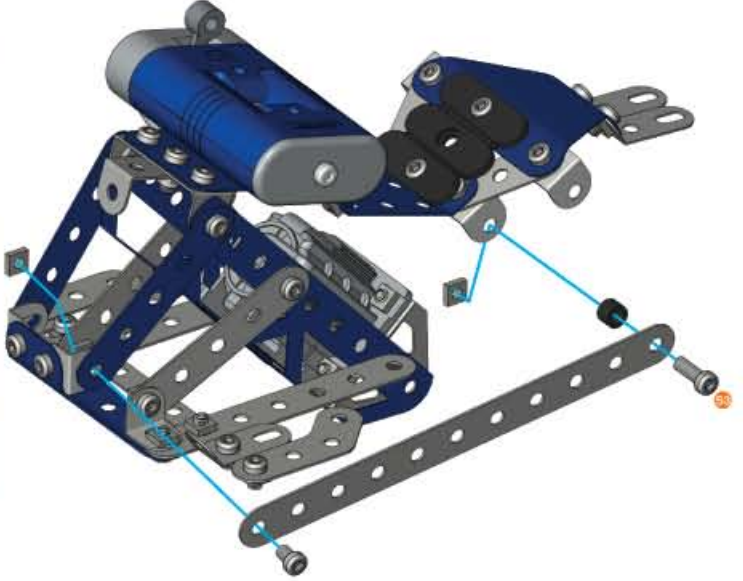

17

-  5,8mm **x1**
15/64"
-  **x1**

-  **S1** **1:1**

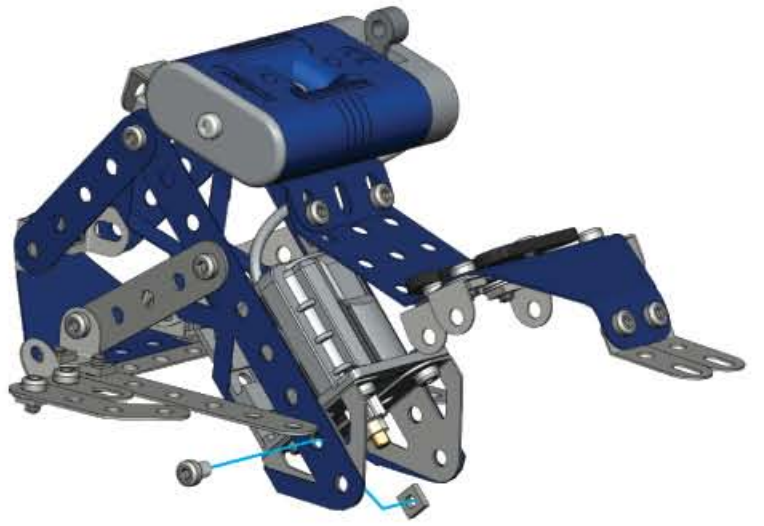

19

-  5,8mm **x1**
15/64"
-  **x1**

-  **S1** **1:1**

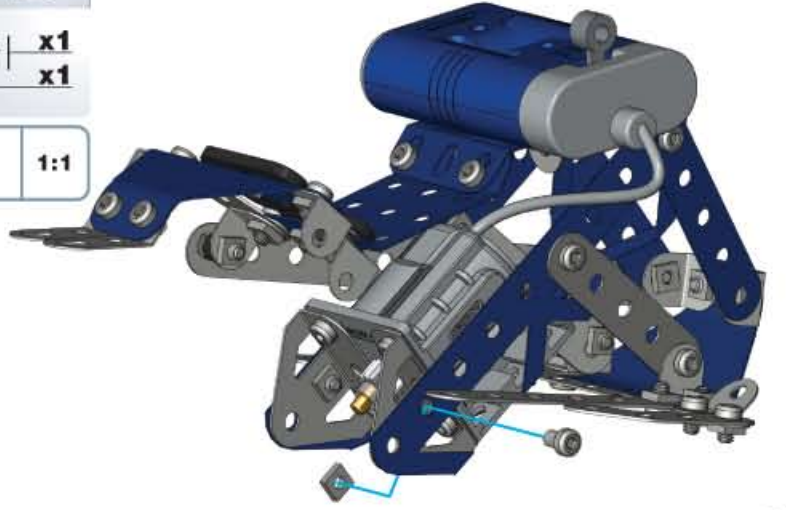



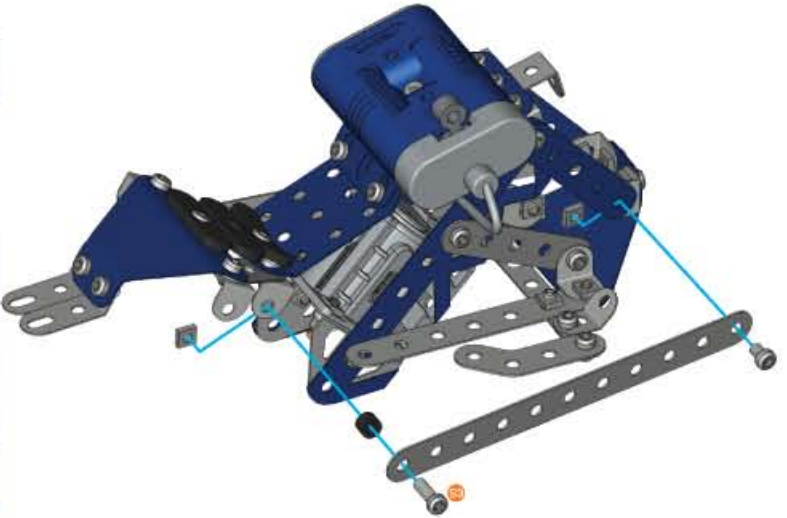

20

-  x1
-  x1
-  x1
-  x1
-  x2
-  x1
-  1:1





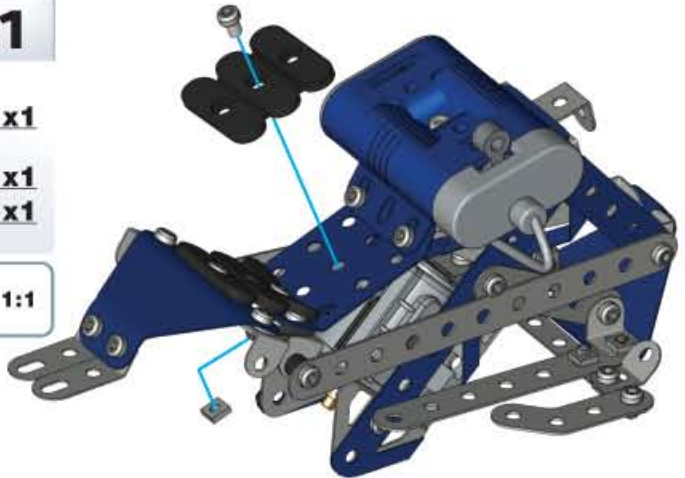

21

-  x1
-  x1
-  x1
-  1:1



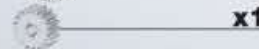
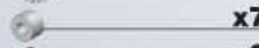

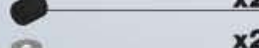
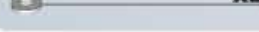
22

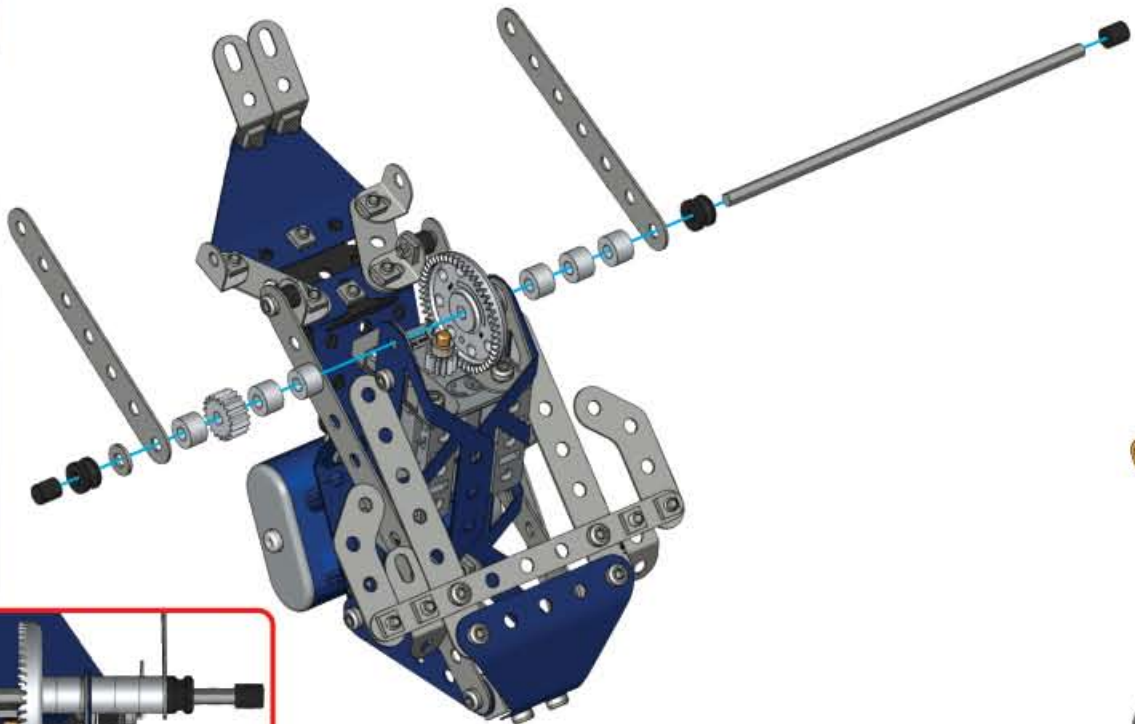
-  x1
-  x2
-  x1
-  x1
-  x7
-  x2
-  x2
-  x2

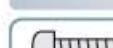

23

-  x2
-  x2
-  x2
-  1:1

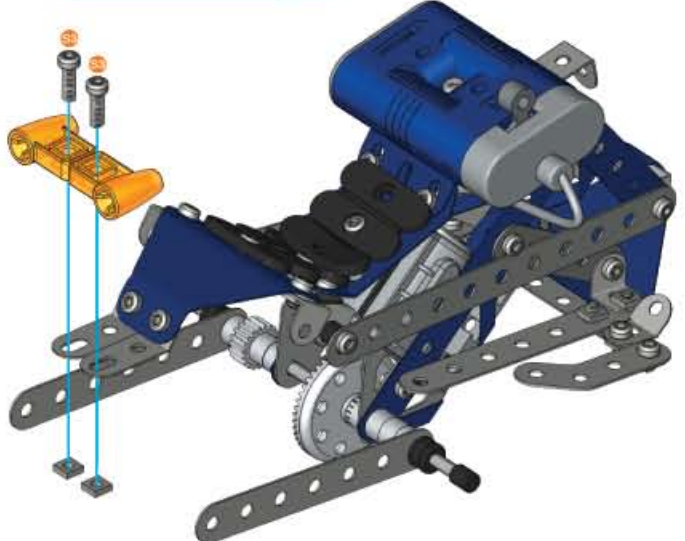

24

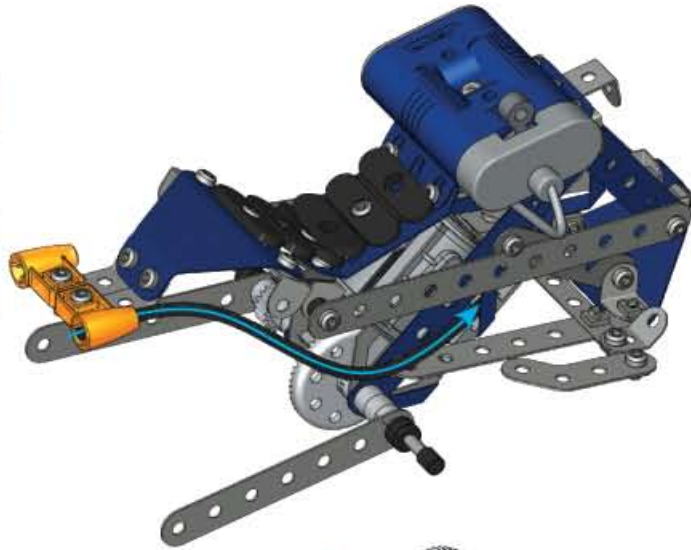

25



26

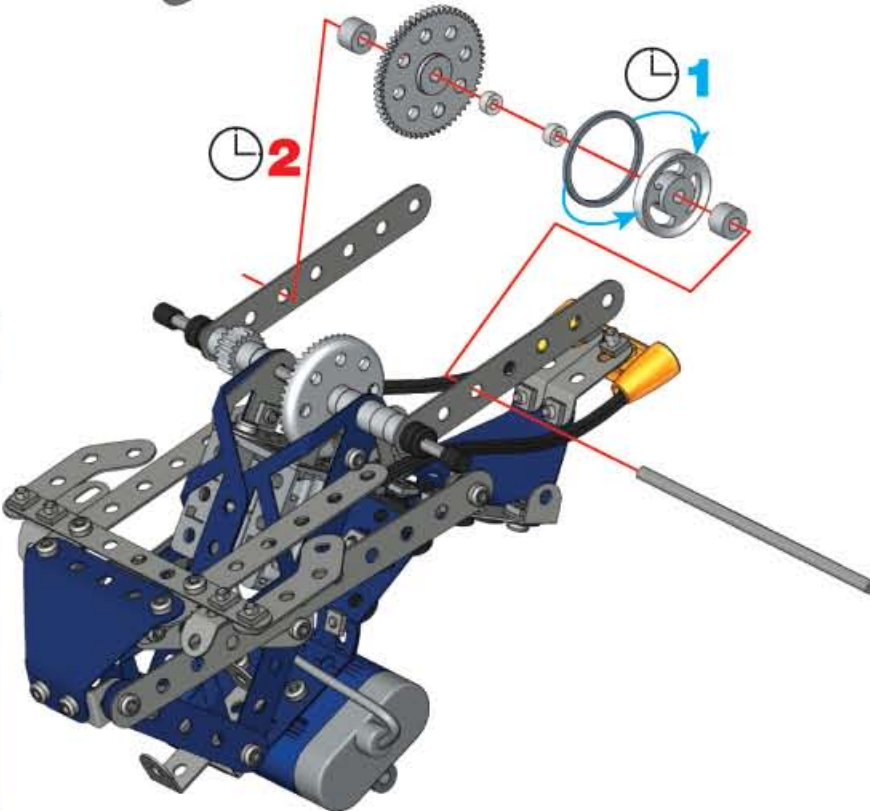
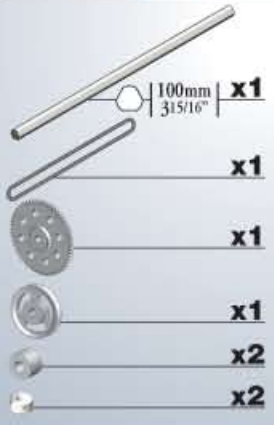



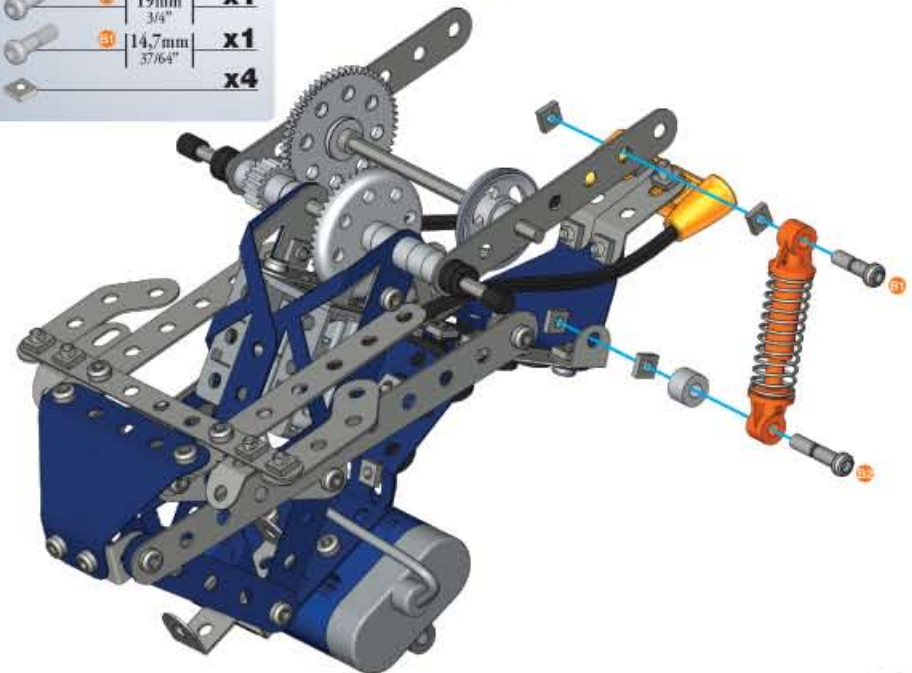
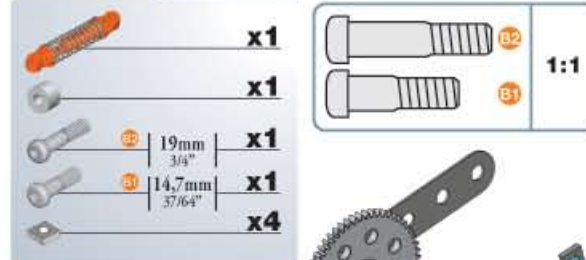

27



1:1



28

-  x1
-  x1
-  | 19mm | x1
3/4"
-  | 14.7mm | x1
37/64"
-  x4

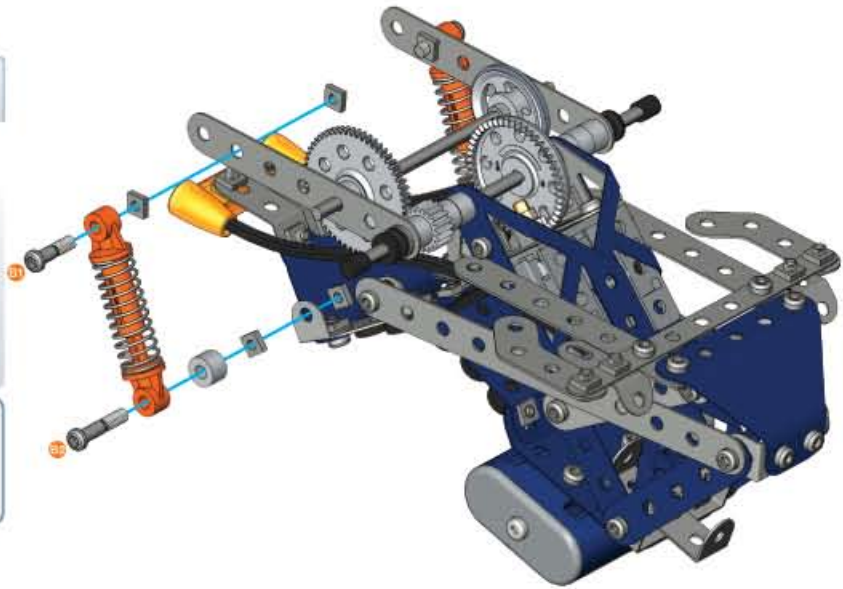
-   B2
 -   B1
- 1:1



29

-  | 115mm | x1
4 1/2"
-  x2
-  x3
-  x2
-  x2

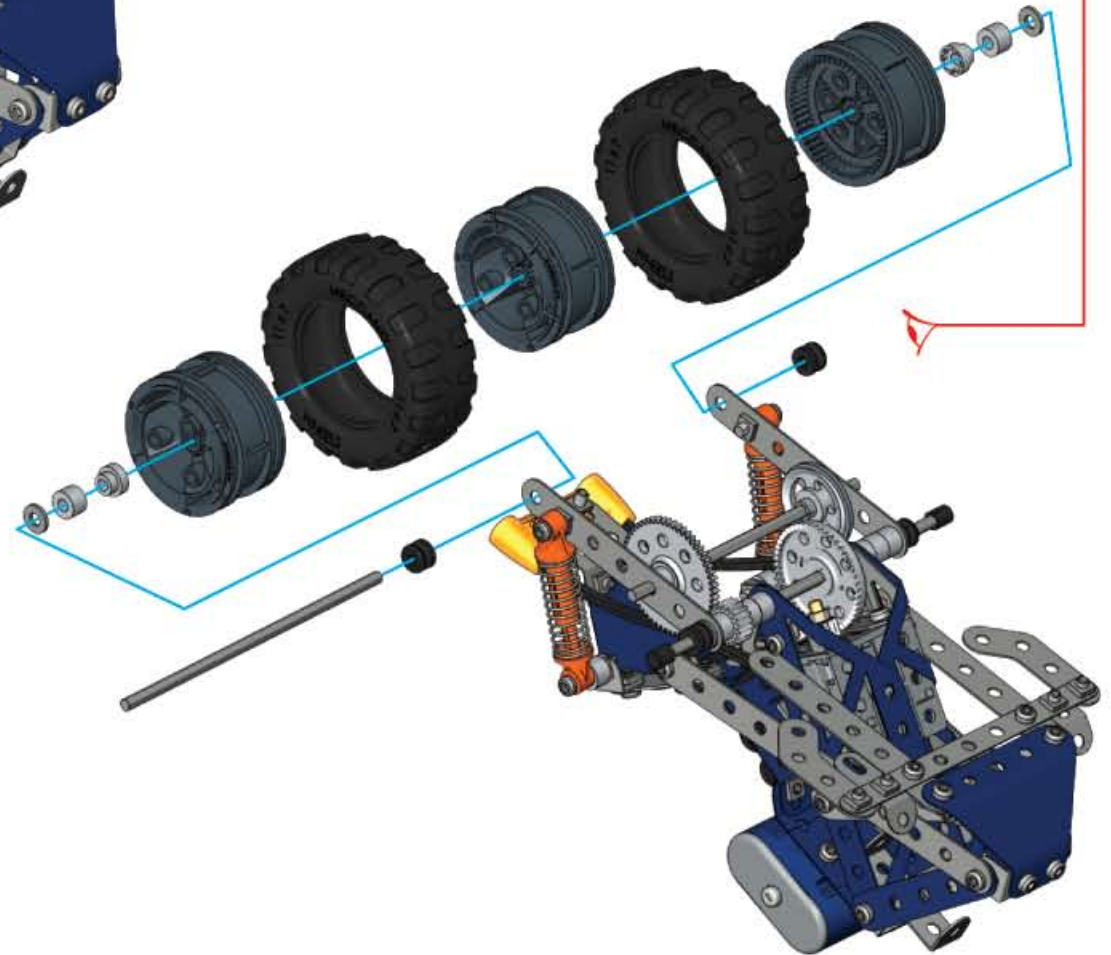

30

-  x1
-  | 5.8mm | x1
15/64"
-  x1

-   S1
- 1:1

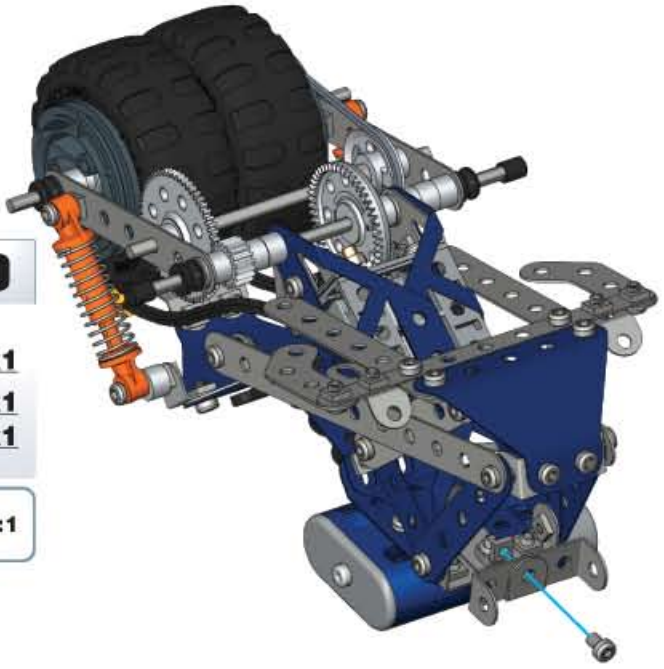

-  1:1



31

	x1
	x2
	x2
	x2
	1:1



32

	x2
	x2
	x2
	x6
	1:1
	1:1

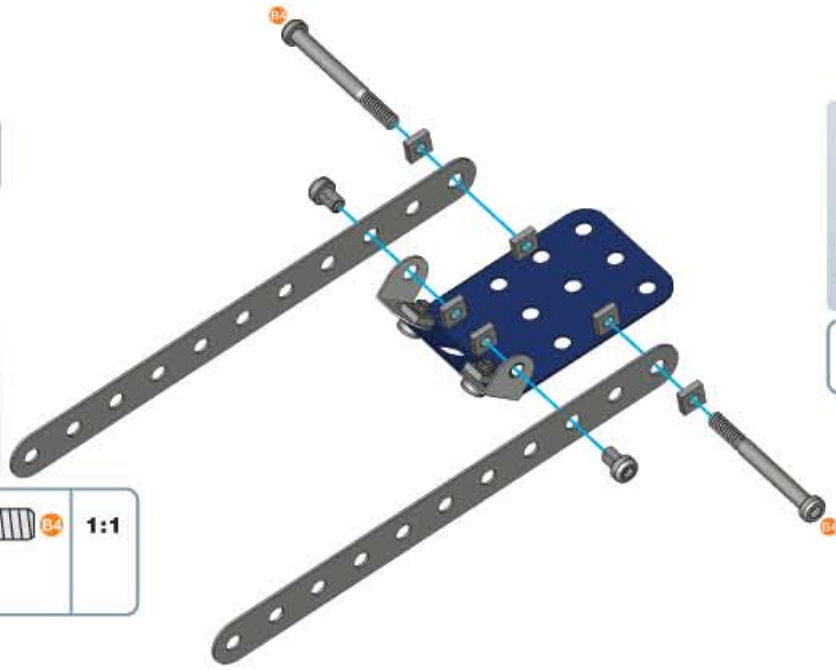

33

	x1
	x1
	x1
	x1
	1:1



34

32 + 33 +

	x1
	x1
	1:1



35

	x2
	x1
	x2
	x3
	x2
	1:1

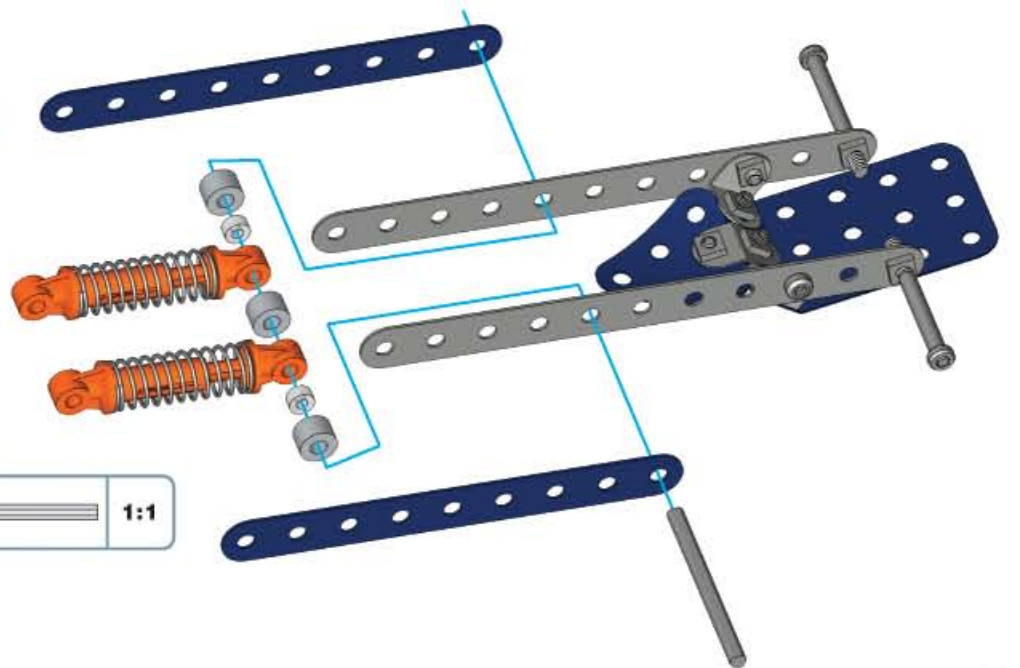

36

	x2
	x2
	x6
	x6

	1:1
--	------------

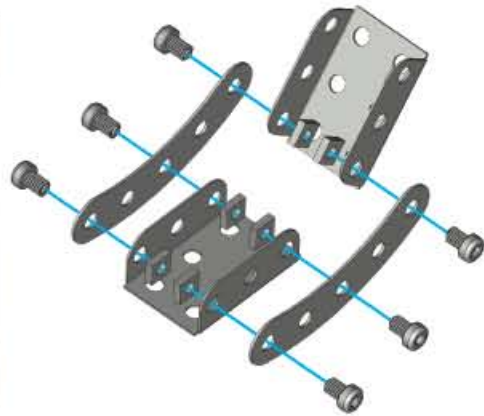

35+36+ **37**

	x2
	x2
	x2

	1:1
--	------------

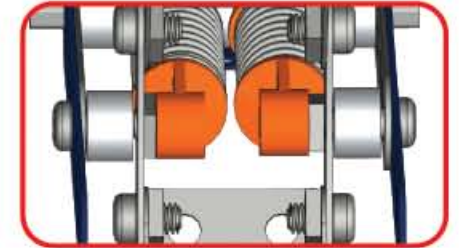
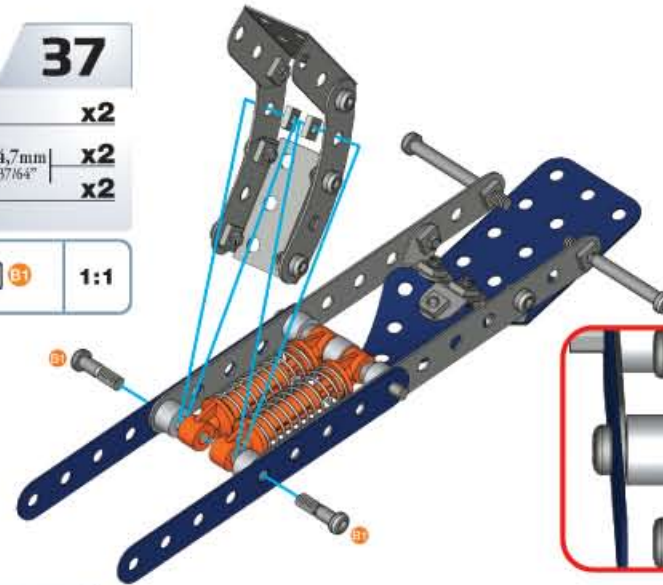

30+37+ **38**

	x2
	x2

	1:1
--	------------

39

	x1
	x1
	x1
	x4
	x2

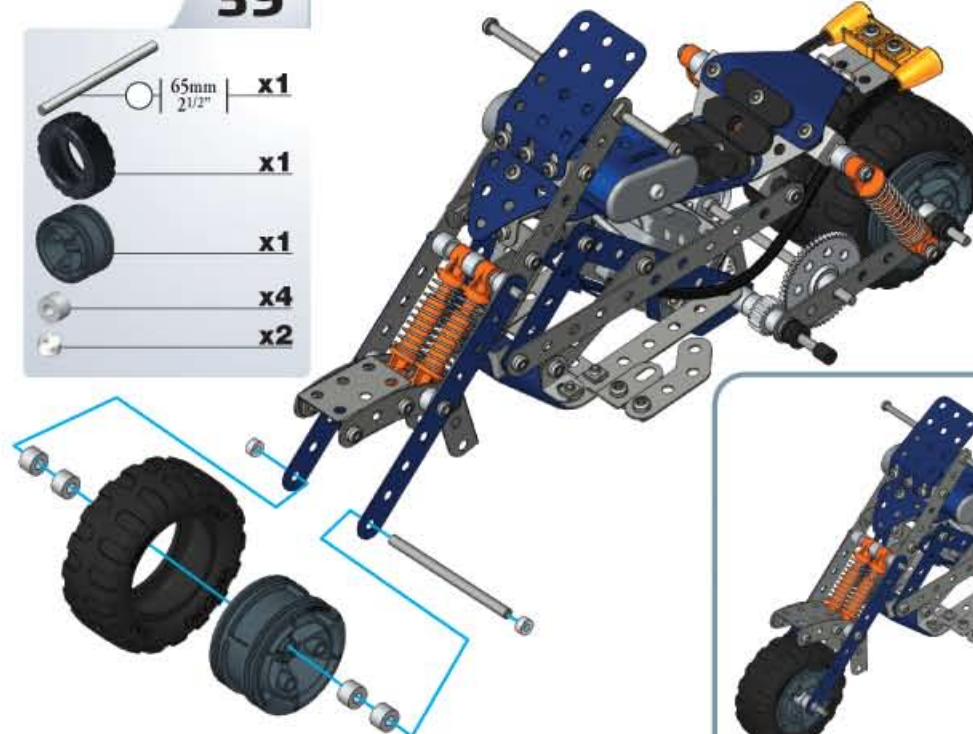

	1:1
--	------------



1

-  **x1**
-  **x2**
-  **5,8mm** | **x4**
-  **15/64"** | **x4**

-  **S1** | **1:1**
-  Scale 1 Escala 1 Mittakaava 1
-  Echelle 1 Schaal 1 Målestok 1
-  Maßstab 1 Escala 1 Мәлімет 1
-  Scala 1 Skala 1 масштаб 1

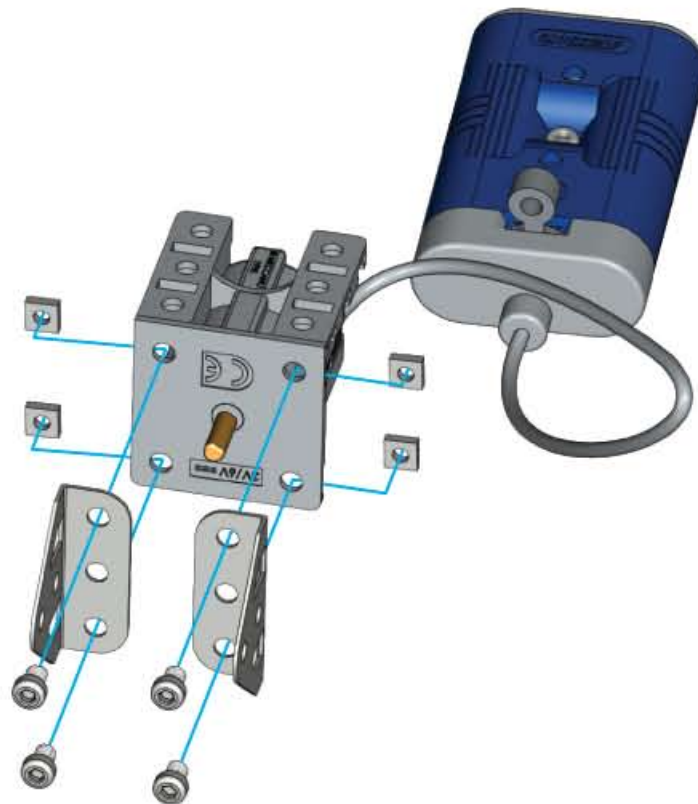

2

-  **x1**
-  **x1**

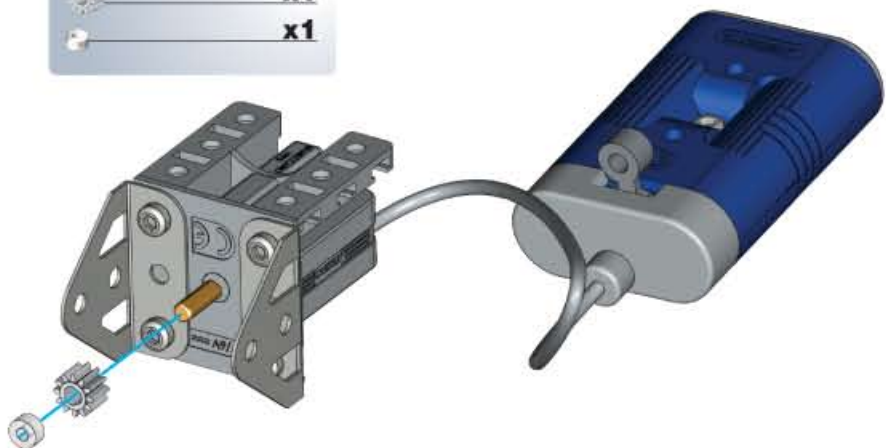

3

-  **x1**
-  **x1**
-  **x1**
-  **5,8mm** | **x2**
-  **15/64"** | **x2**

-  **S1** | **1:1**

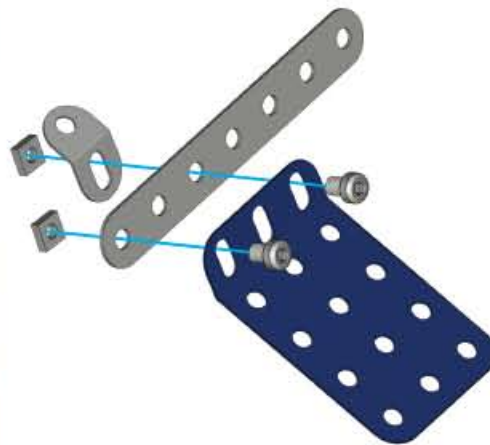

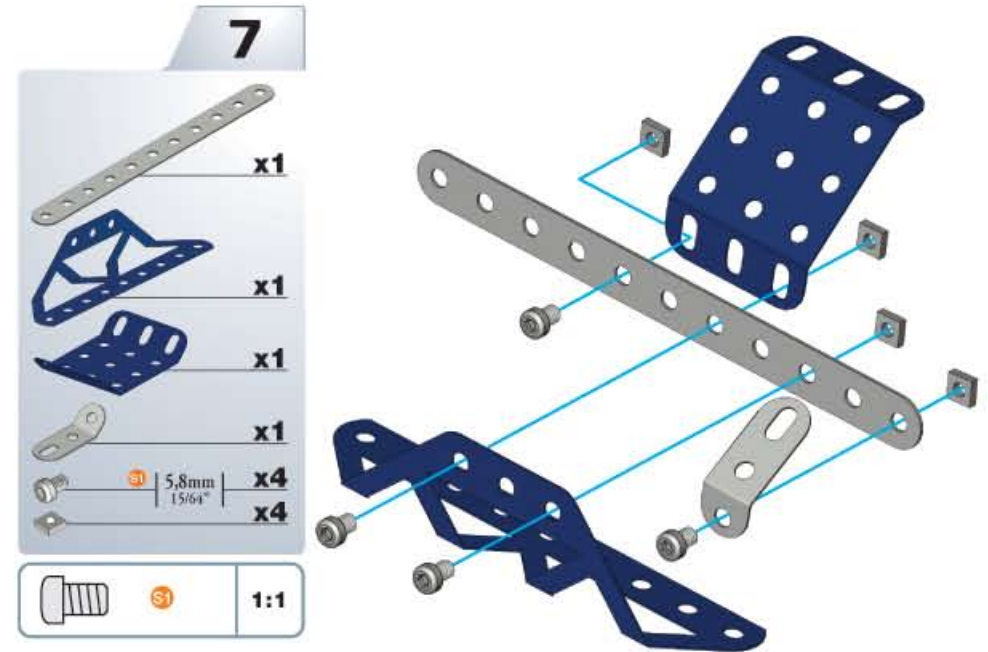
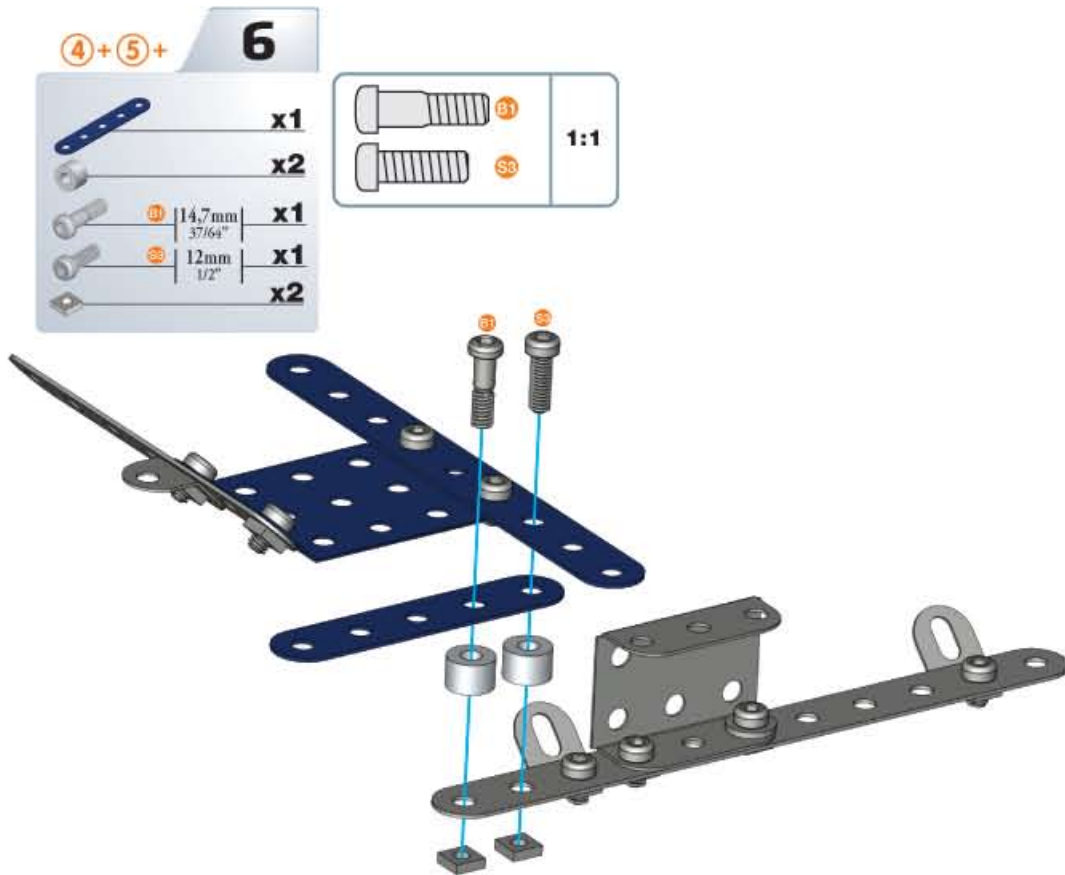
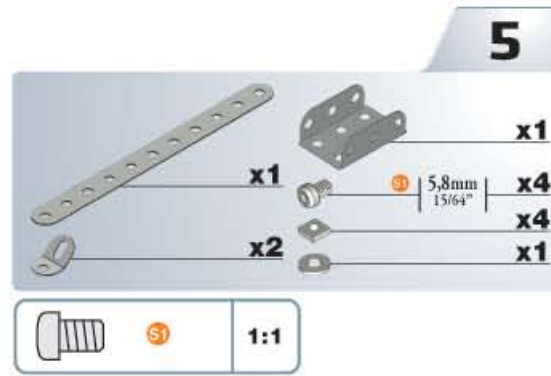
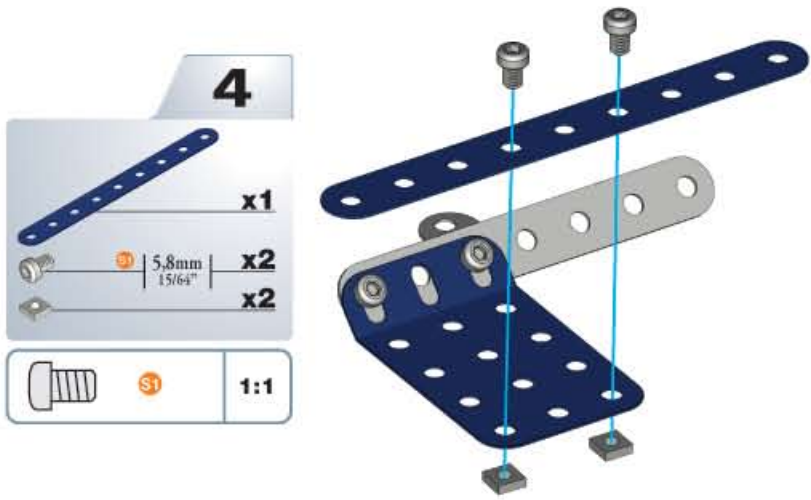

8

⑥+⑦+

	5,8mm 15/64"	x2
		x2

	S1	1:1
--	-----------	------------

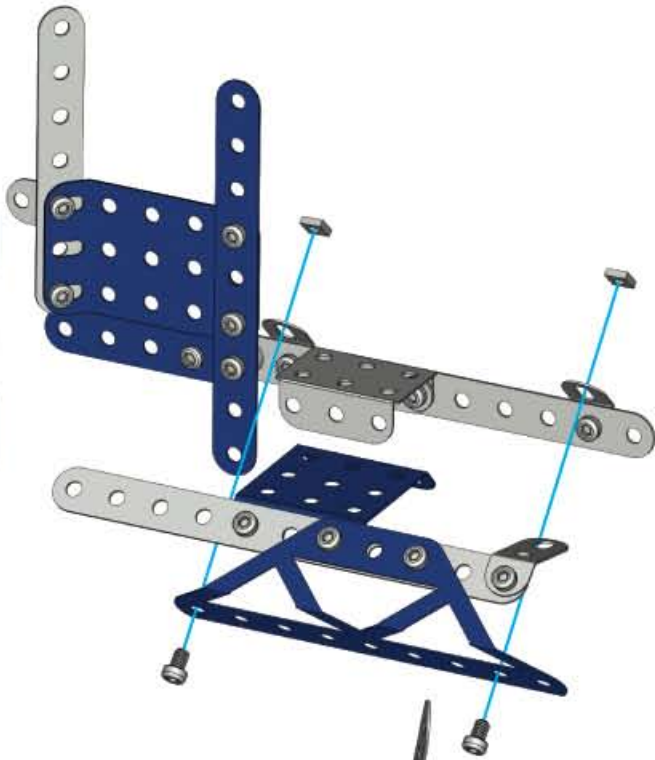

10



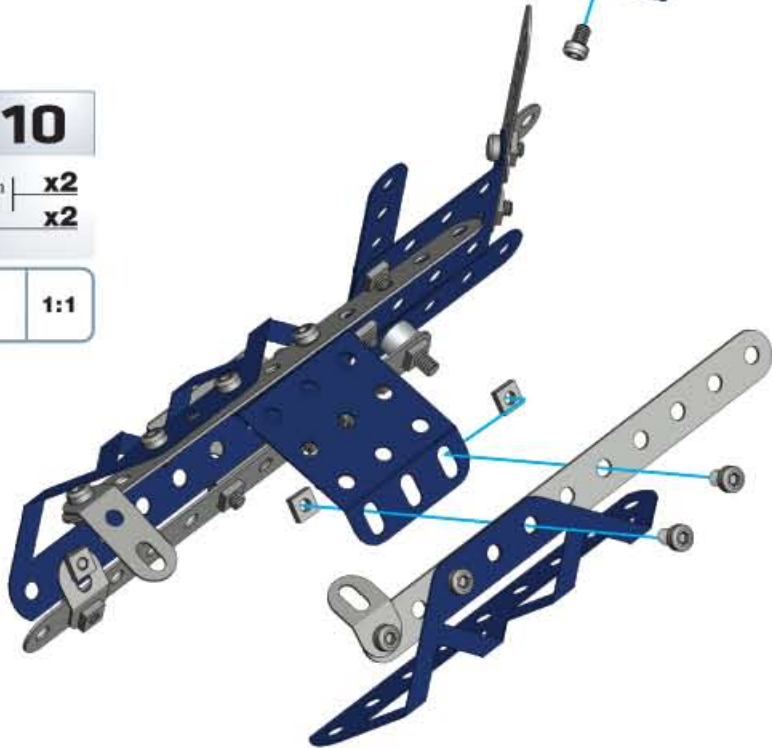

⑧+⑨+

	5,8mm 15/64"	x2
		x2

	S1	1:1
--	-----------	------------





9

	x1	
	x1	
	x1	
	5,8mm 15/64"	x2
		x2

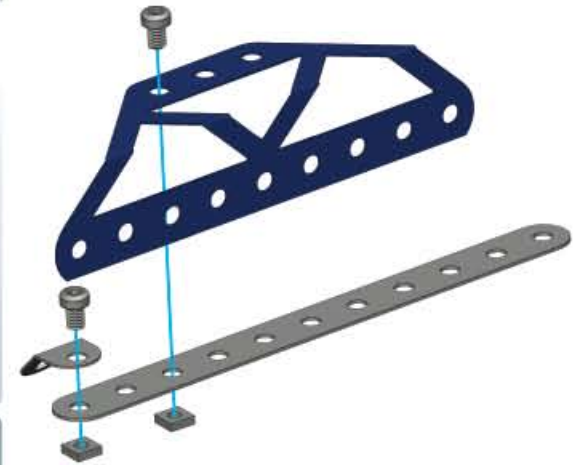
	S1	1:1
---	-----------	------------





11

	x1	
	x1	
	x1	
	5,8mm 15/64"	x2
		x2

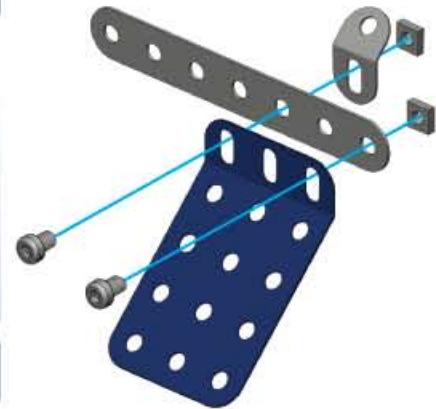
	S1	1:1
---	-----------	------------



12

-  **x1**
-  **x2** | 5,8mm | 15/64"
-  **x2**

 **S1** | **1:1**

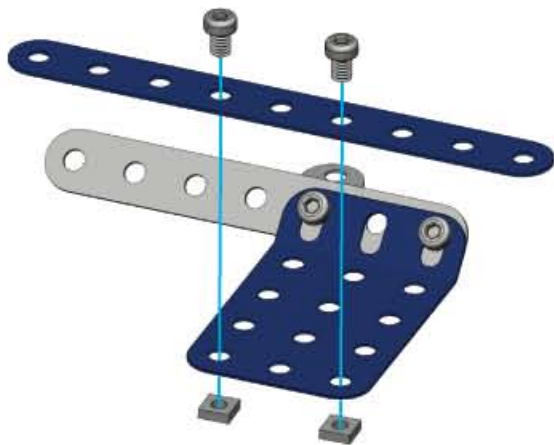



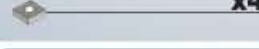

13

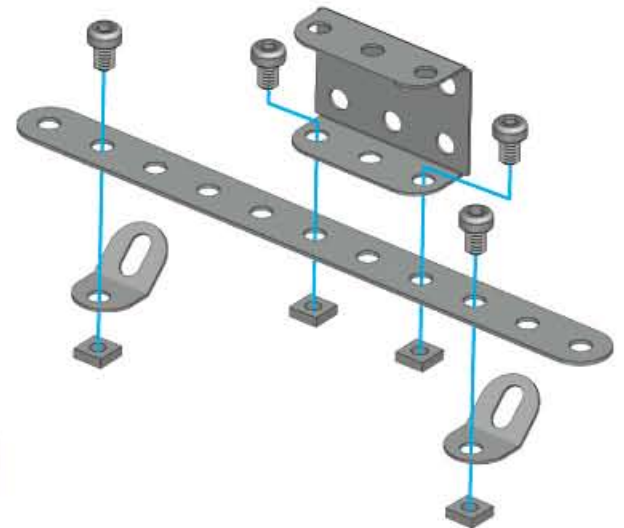
-  **x1**
-  **x1**
-  **x2**
-  **x4** | 5,8mm | 15/64"
-  **x4**

 **S1** | **1:1**

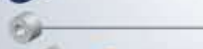

10 + 13 + 14

-  **x1**
-  **x2**
-  **x1** | 14,7mm | 57/64"
-  **x1** | 12mm | 1/2"
-  **x2**

 **S1** | **1:1**

 **S2**

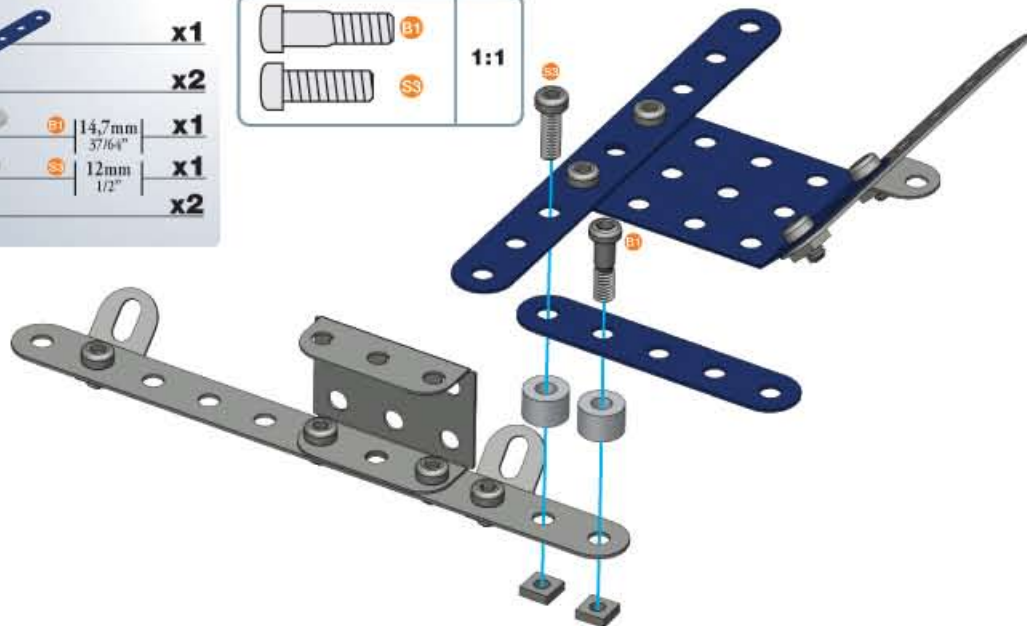

10 + 14 + 15

-  **x2** | 5,8mm | 15/64"
-  **x2**

 **S1** | **1:1**

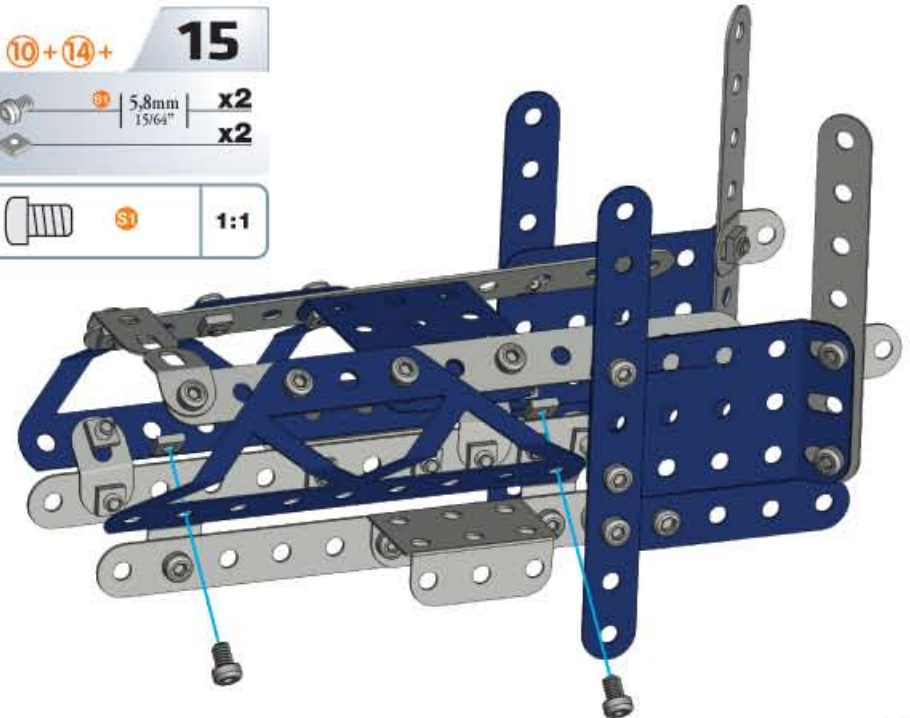



16

② + ⑮ +

	x2
	x2
	1:1

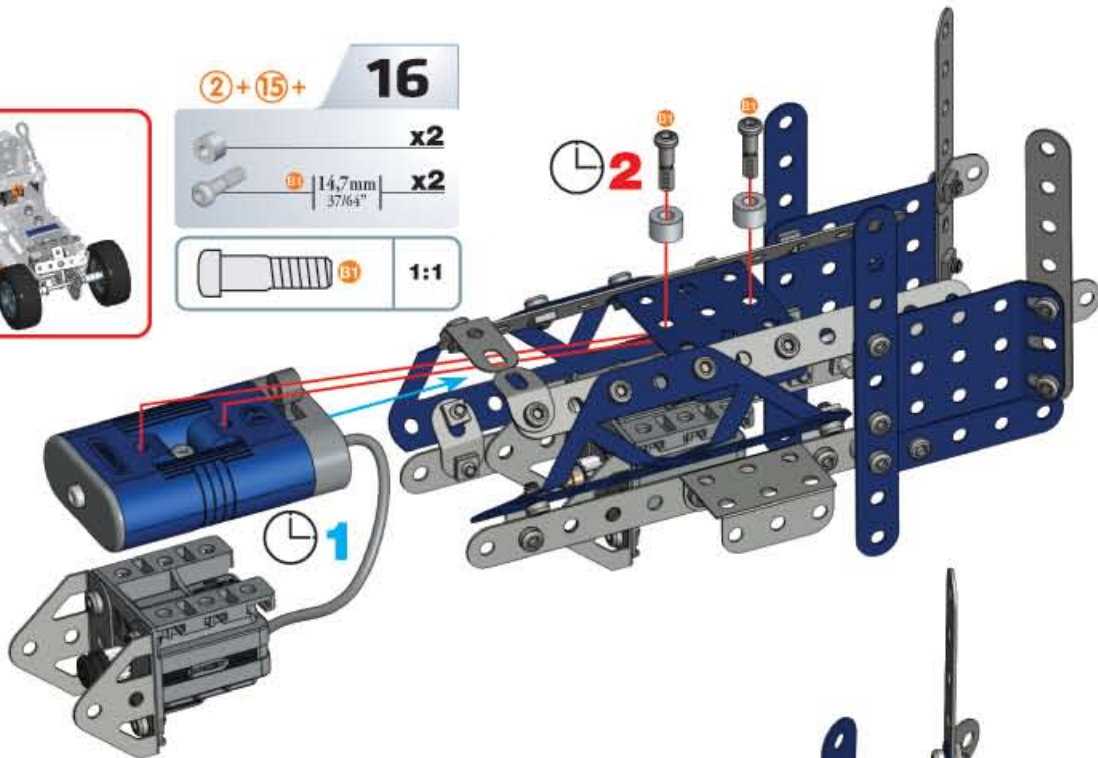

17

	x2
	x2
	1:1

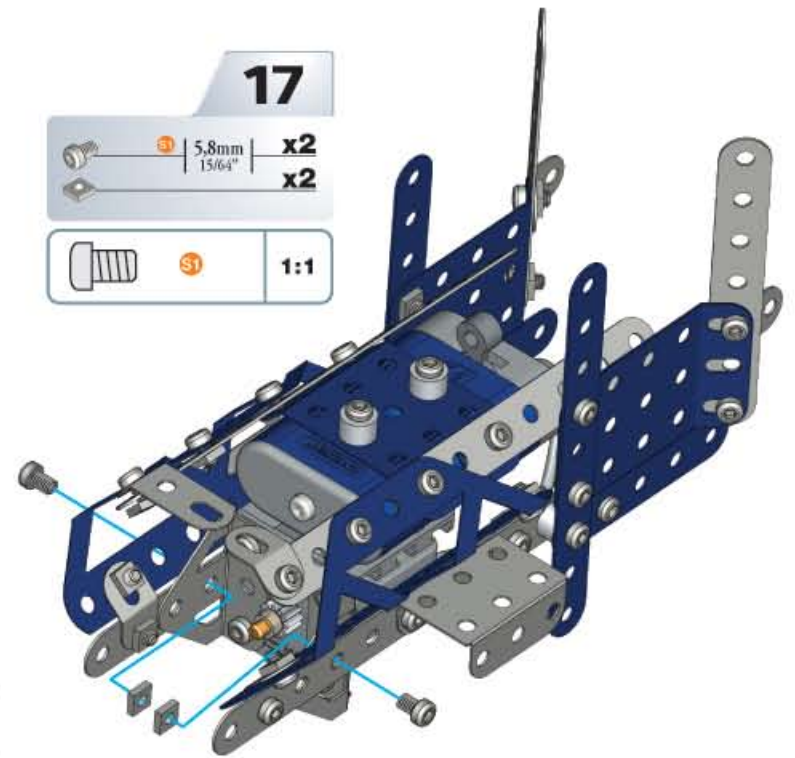

18

	x1
	x1
	x1
	x2
	x2
	1:1

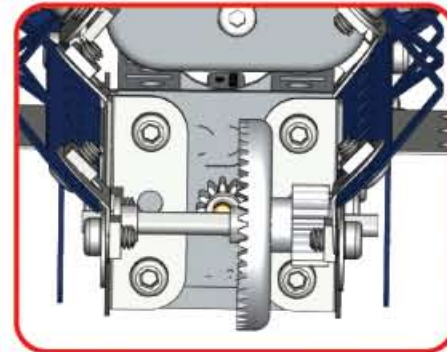
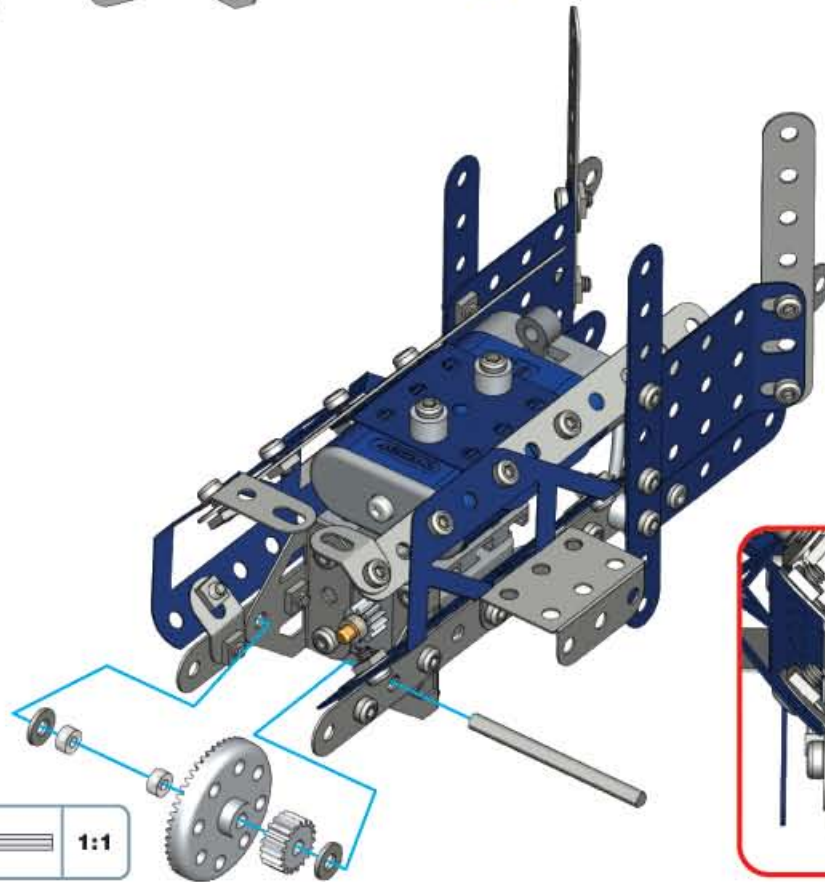

19

-  130mm
5 1/8" x1
-  x2
-  x2
-  x1
-  x2
-  x6
-  x1
-  x5
-  x1

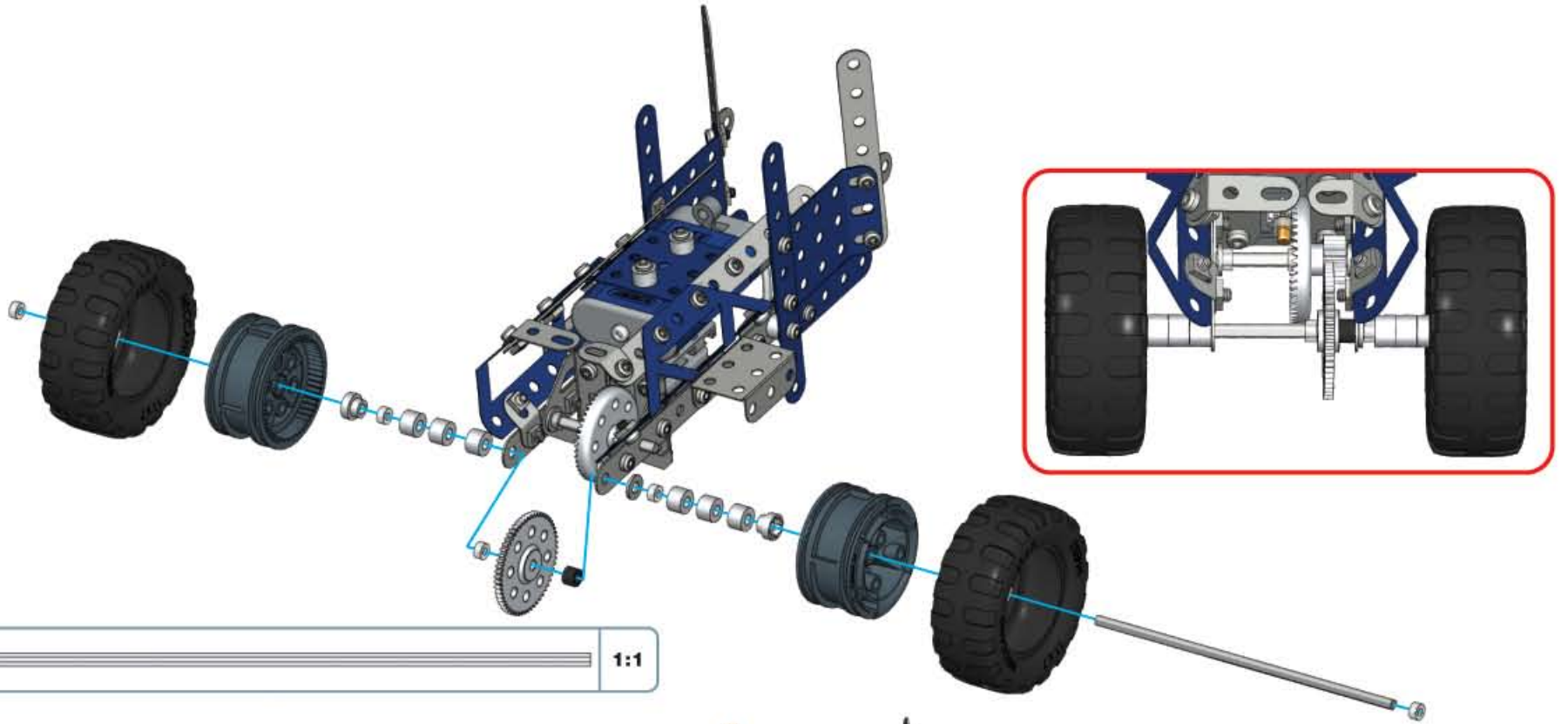

20

-  x1
-  x1
-  5,8mm
15/64" x1
-  x1

 S1 1:1



19 + 20 + 21



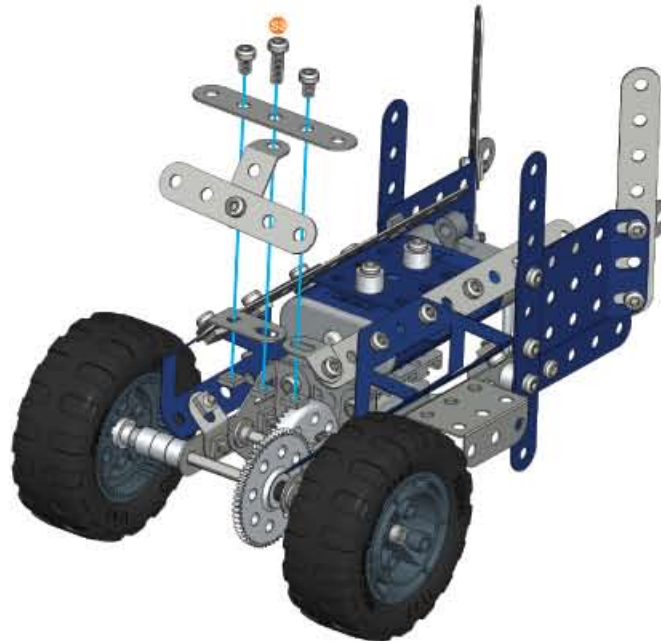

-  x1
-  12mm
1/2" x1
-  5,8mm
15/64" x2
-  x3

 S2 1:1

 S1 1:1



22

-  **x2**
-  **x2** (38,1mm | 1 1/2")
-  **x2** (14,7mm | 5/8")
-  **x4**

1:1

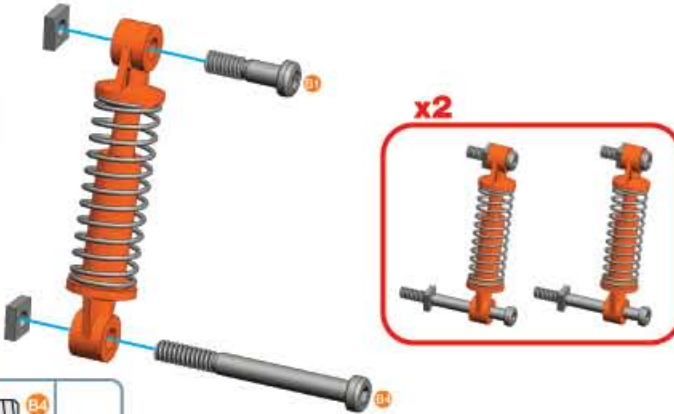

23

x2

(21) + (22) +

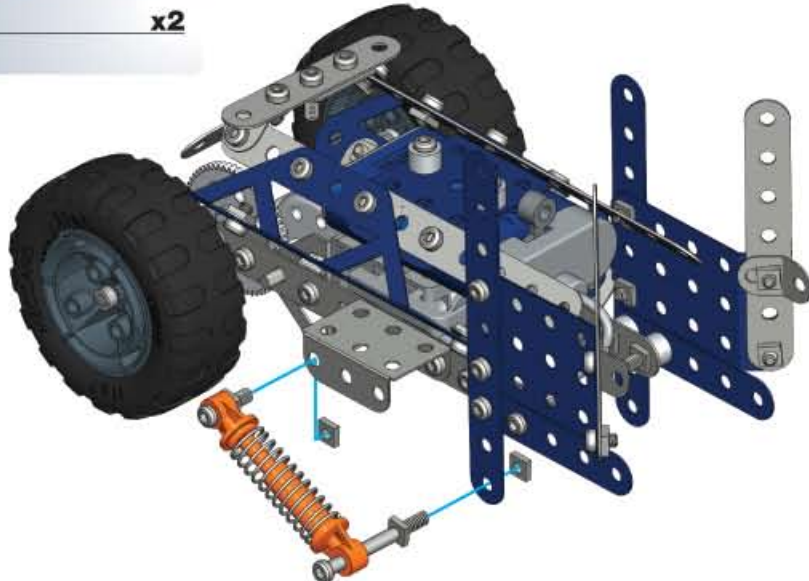



24

x2

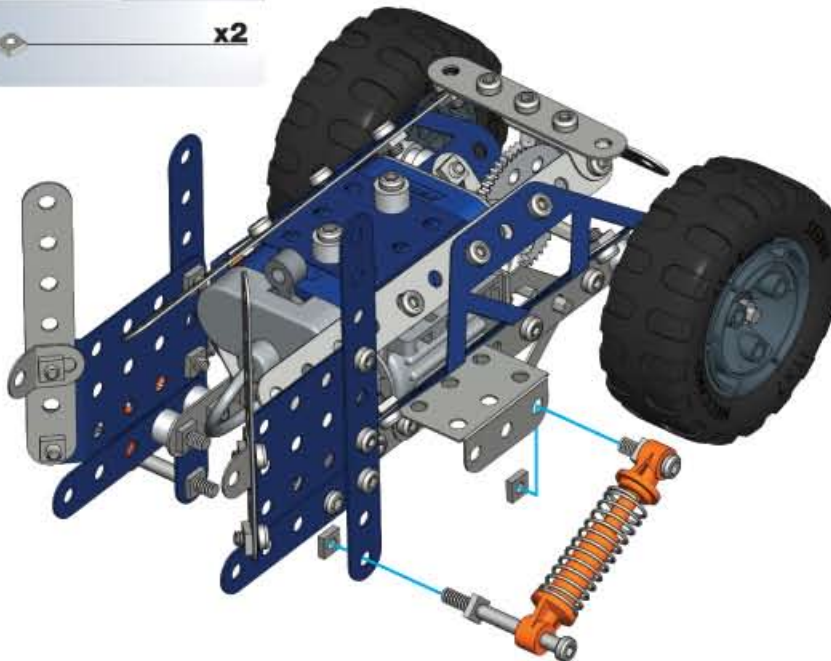
(22) + (23) +



25

-  **x2**
-  **x2** (12mm | 1/2")
-  **x2**

1:1

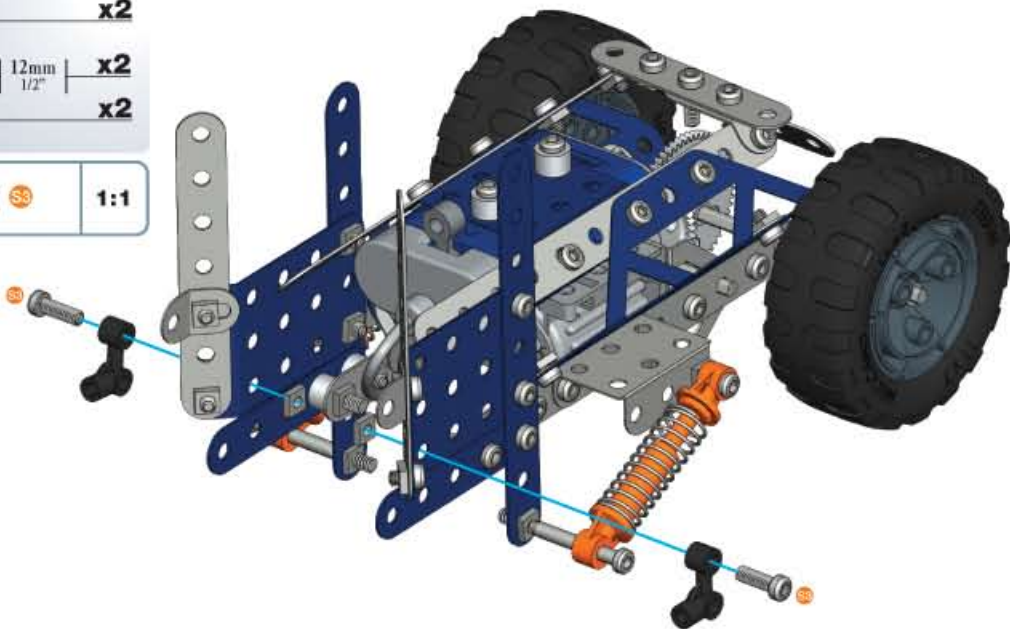

26

-  100mm | 315/16" | x1
-  x2
-  x2

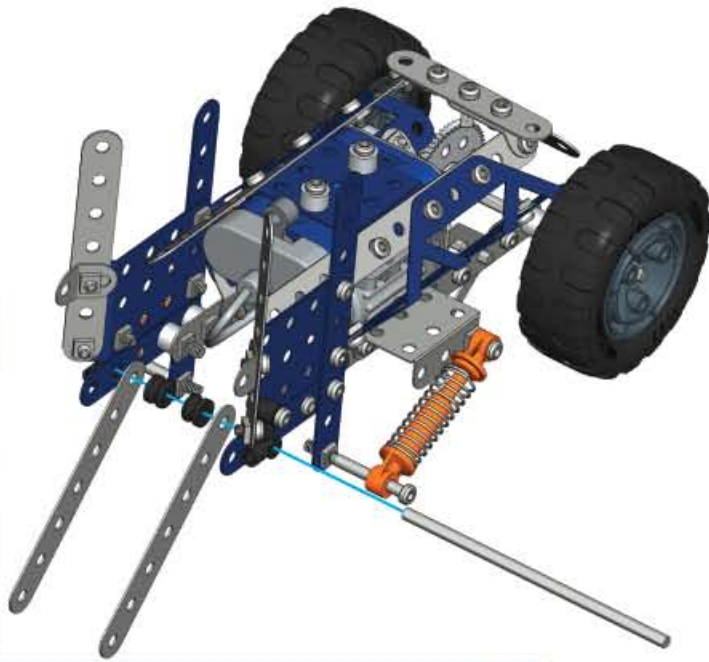

1:1

27

-  100mm | 315/16" | x1
-  x2
-  x2
-  x2

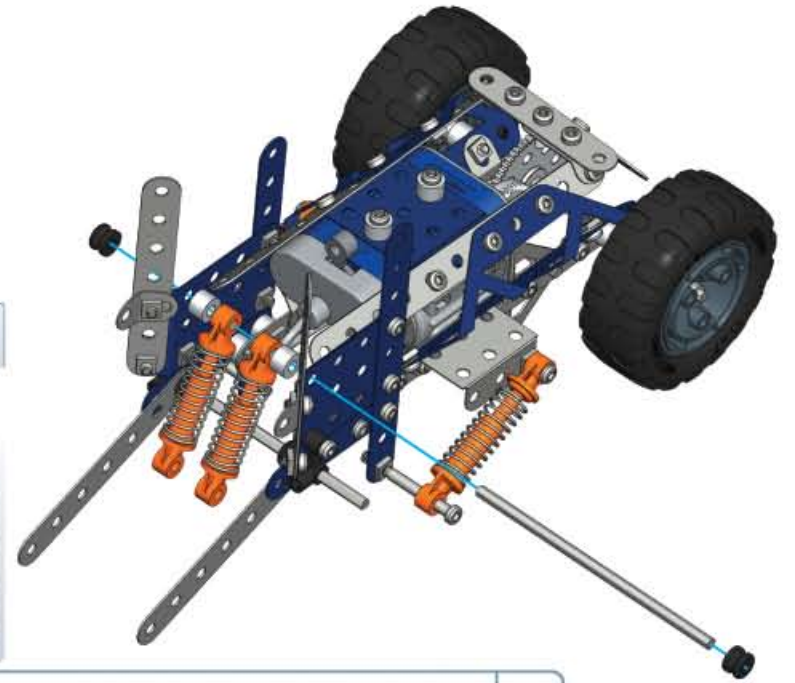

1:1

28

-  x2
-  19mm | 3/4" | x2
-  x2

-  1:1

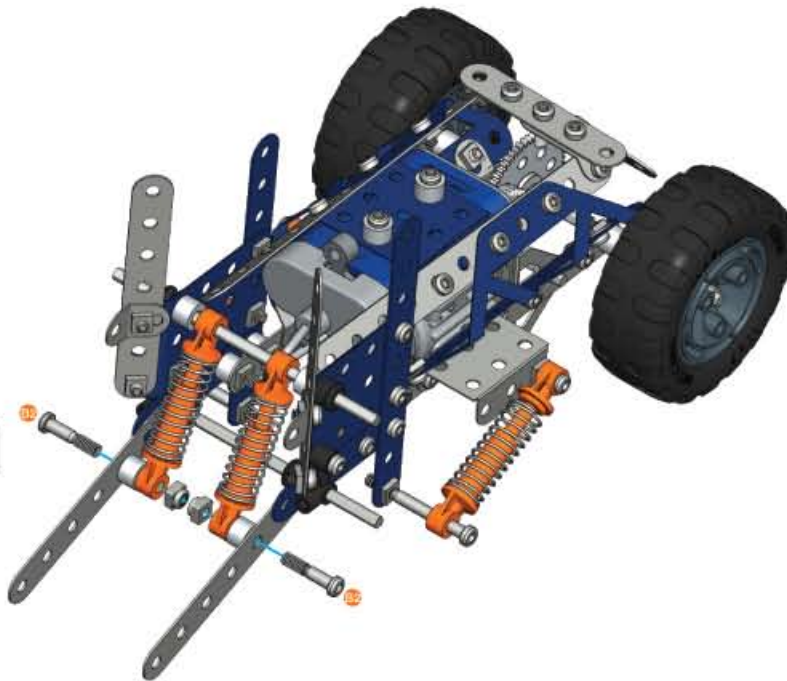

29

-  x1
-  x2
-  5,8mm | 15/64" | x2
-  x2

-  1:1

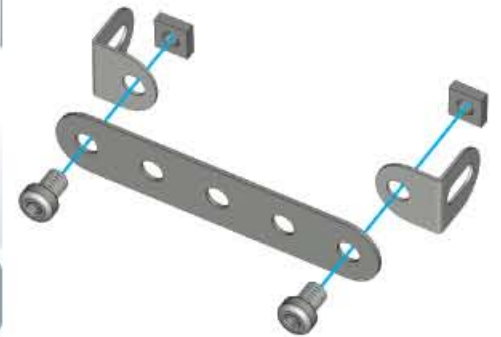





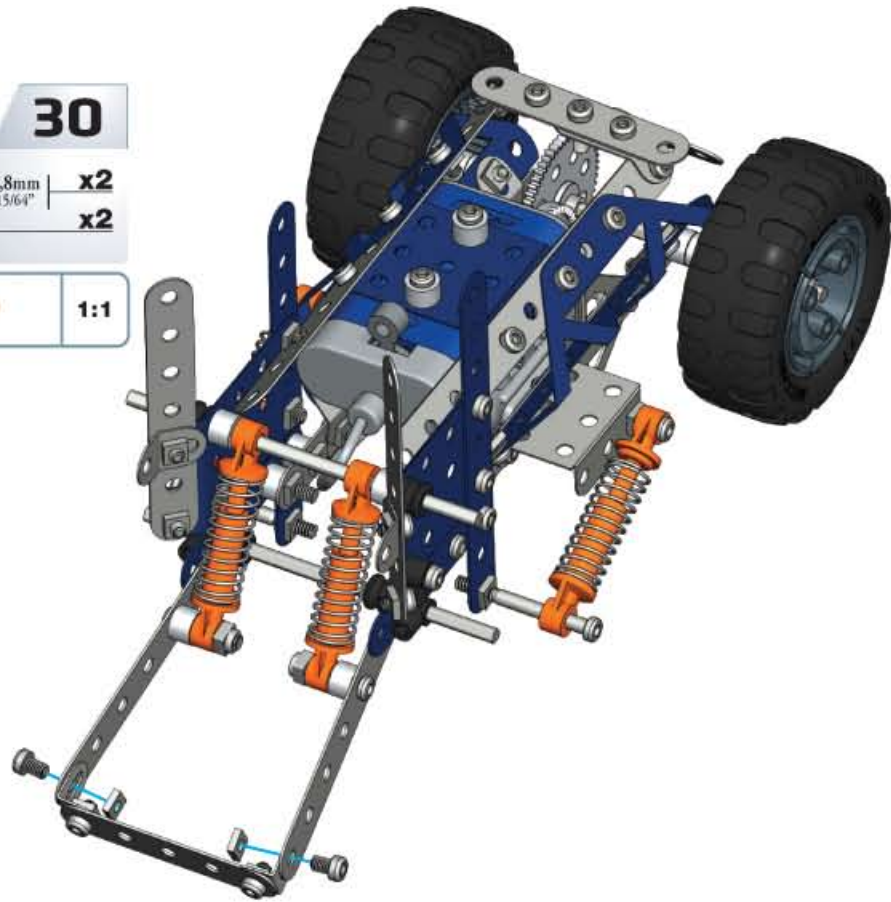

28+29+ **30**

	5,8mm 15/64"	x2
		x2

	S1	1:1
--	-----------	------------



31

	x1		x2
	x2		x1
			5,8mm 15/64" x3
			x3

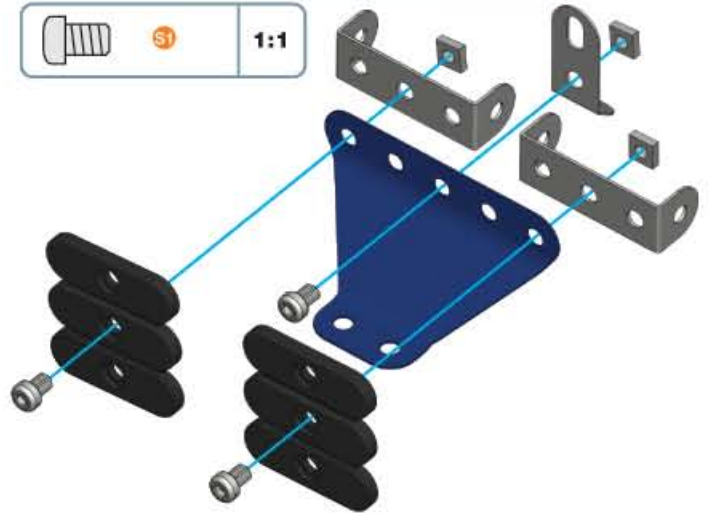

32

	x1
	5,8mm 15/64" x2
	x2

	S1	1:1
--	-----------	------------

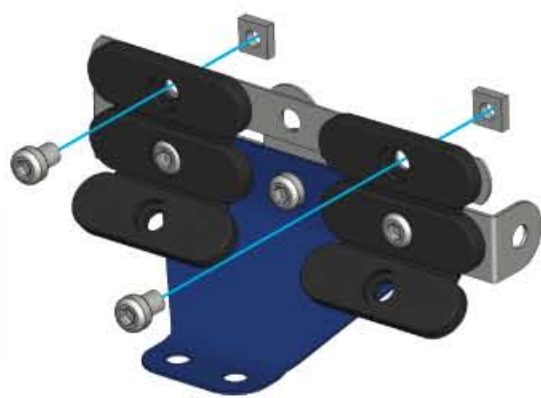

33

	x1
	5,8mm 15/64" x1
	x1

	S1	1:1
---	-----------	------------

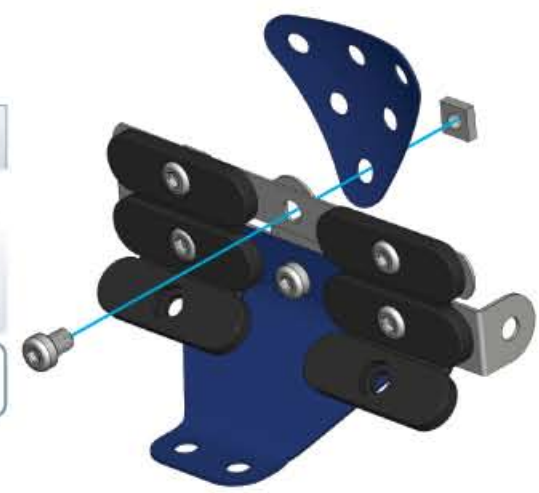

30+

34

-  x1
-  5,8mm | 15/64" x1
-  x1

-  S1 1:1

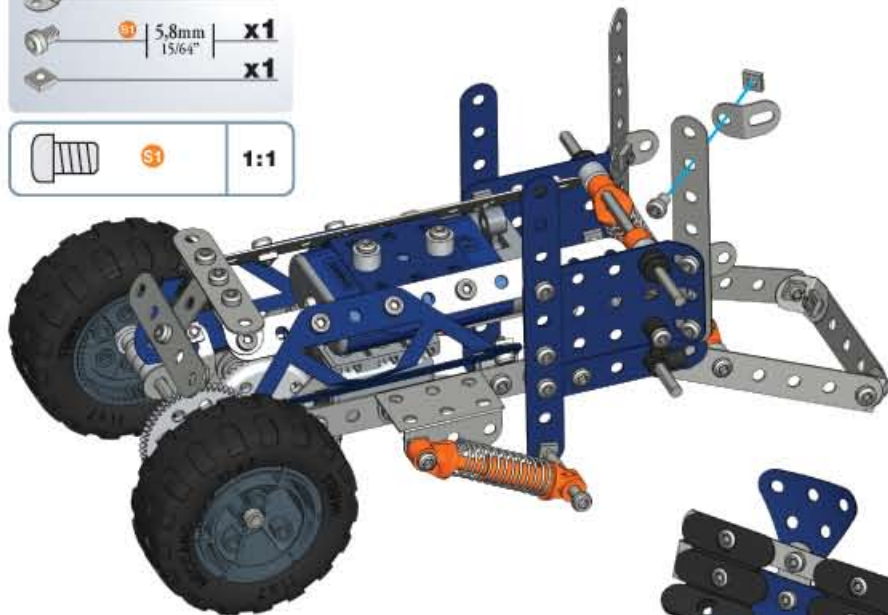

35

-  x1
-  x1
-  5,8mm | 15/64" x2
-  x2

-  S1 1:1

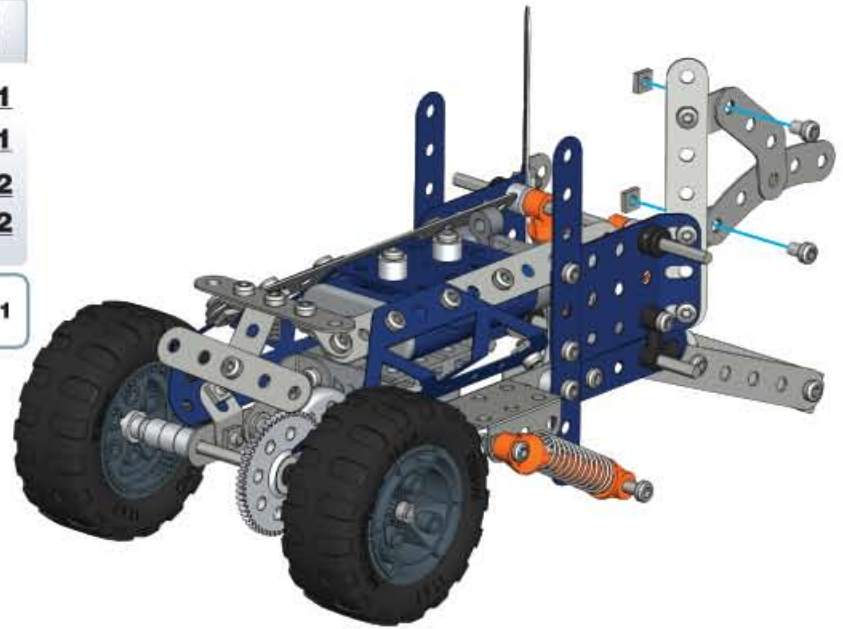

33+35+

36

-  5,8mm | 15/64" x1
-  x1

-  S1 1:1

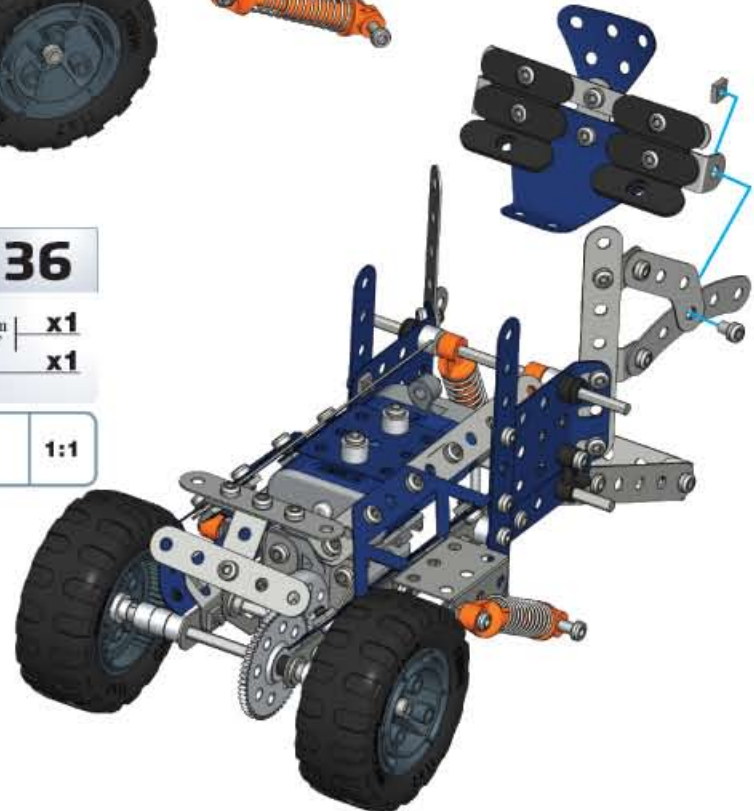

37

-  x1
-  5,8mm | 15/64" x2
-  x2

-  S1 1:1

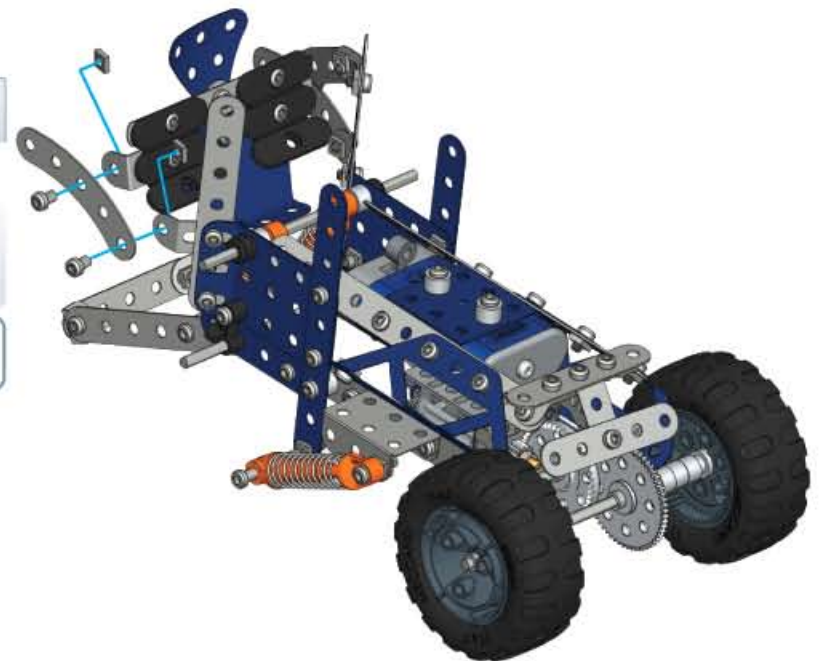

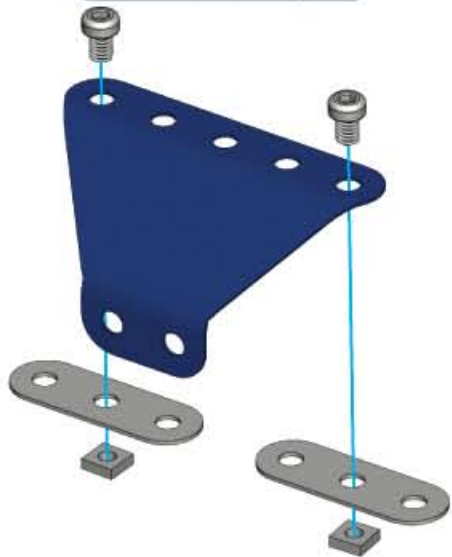
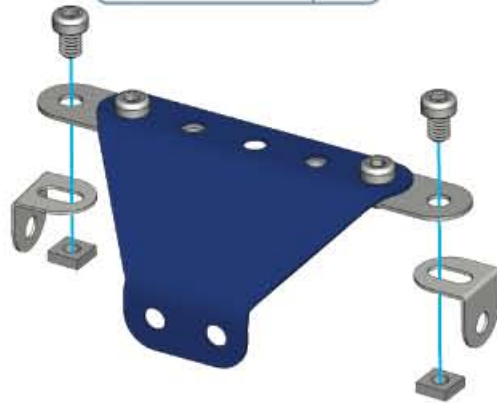
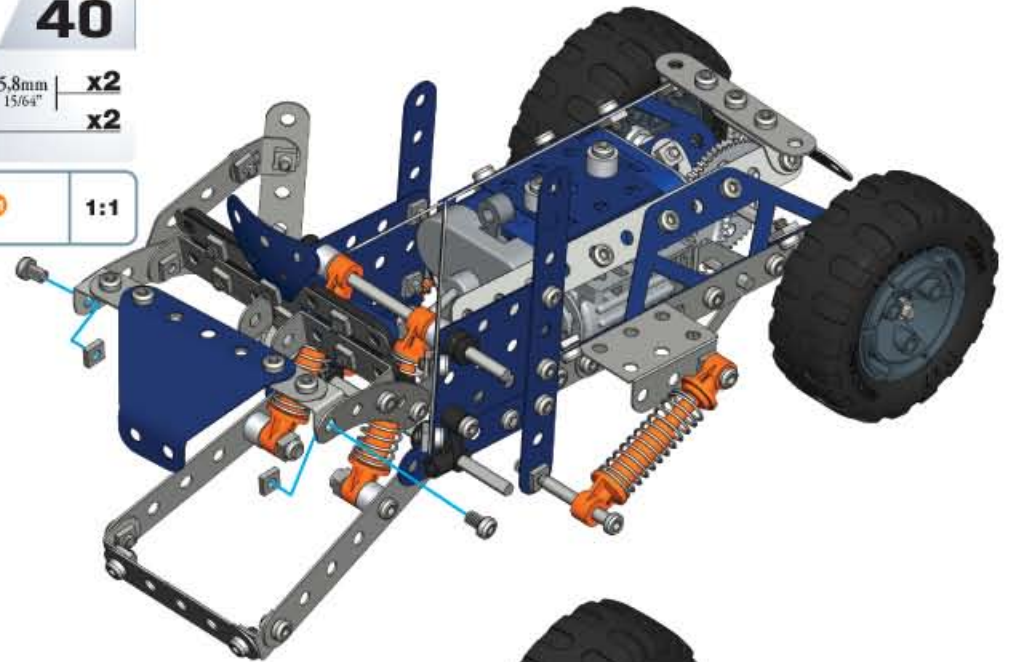
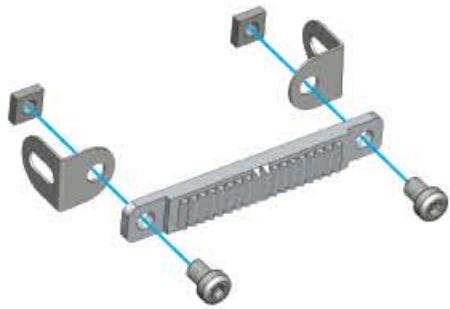
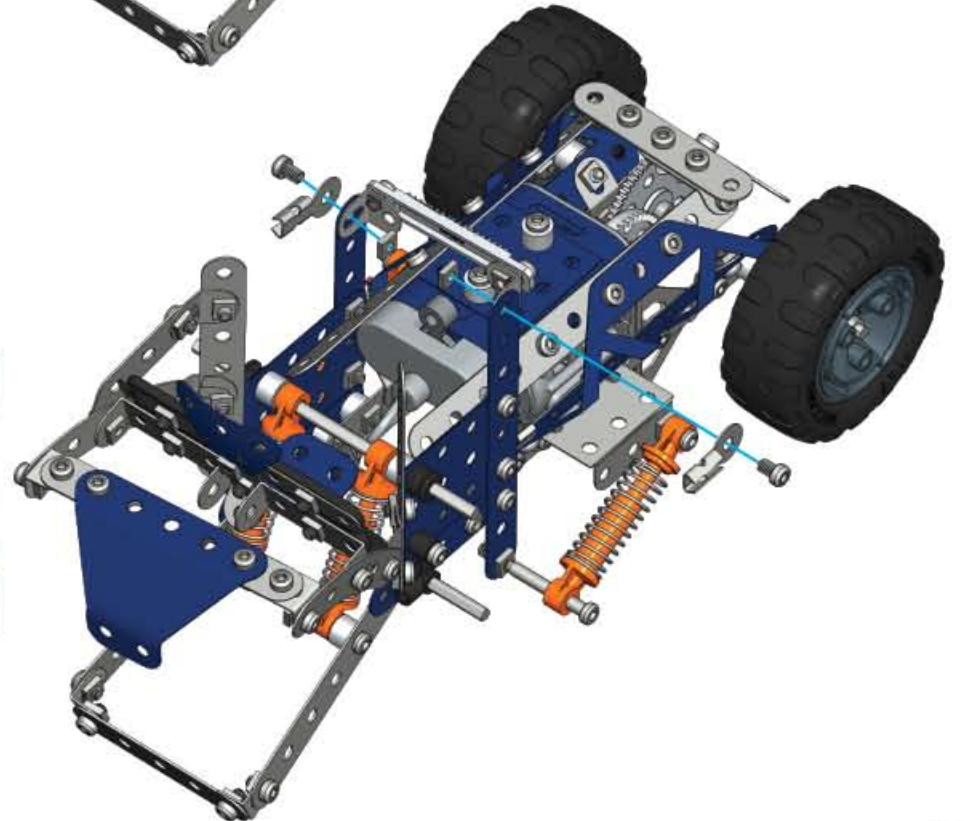
38**39****37+39+** **40****41****42**

43

-  x1
-  x1
-  x1
-  x1

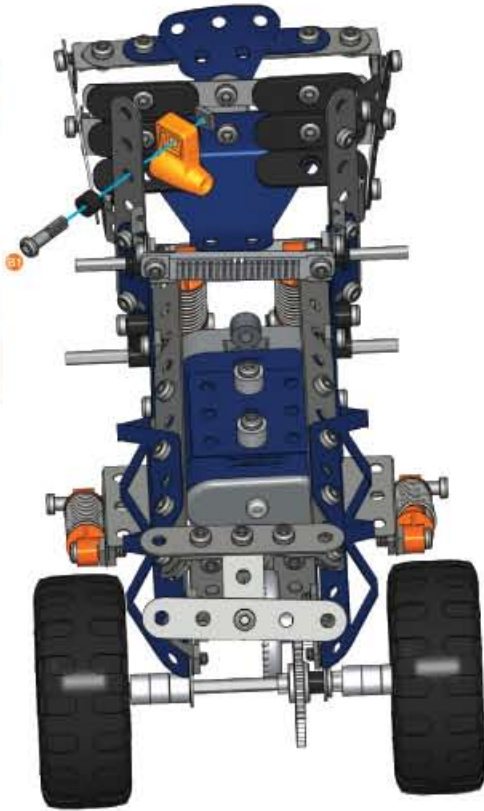

44

-  x1
-  x1
-  x1
-  x1

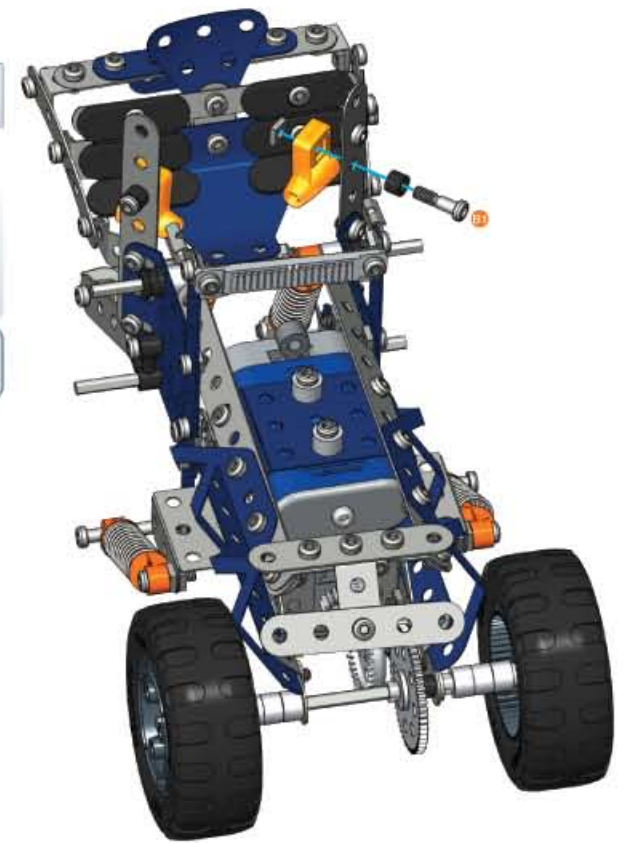

45

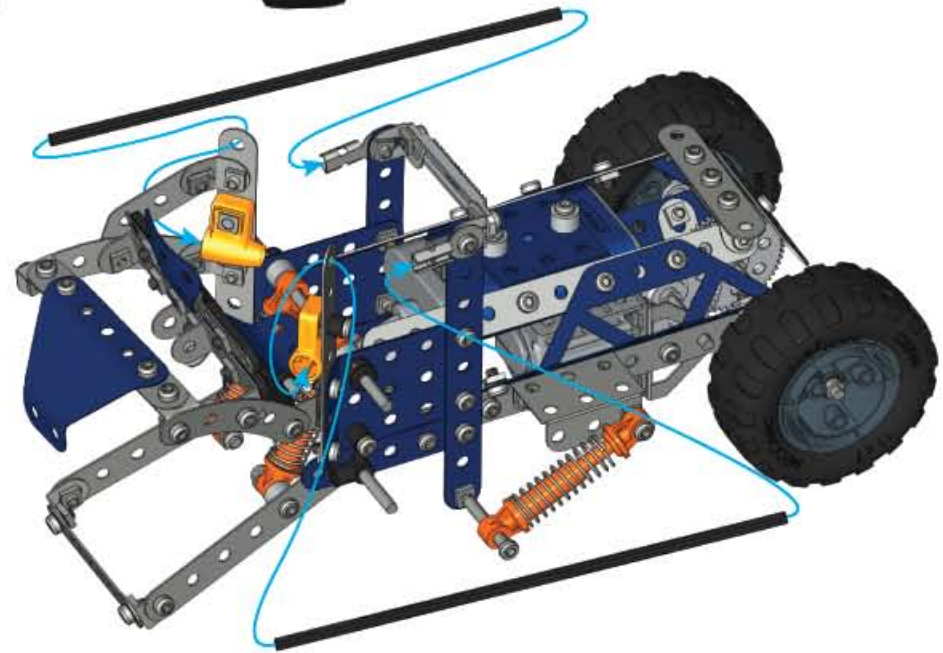
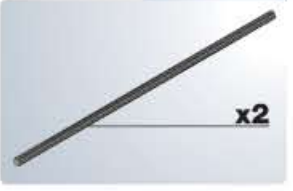

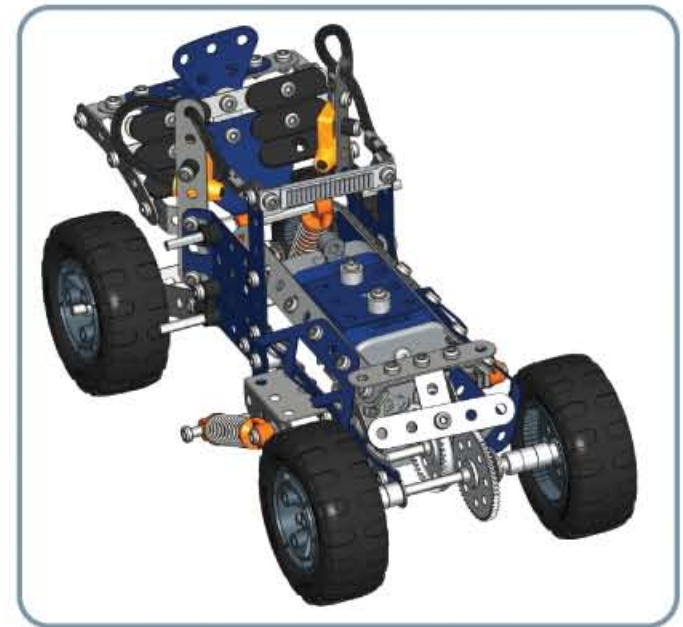
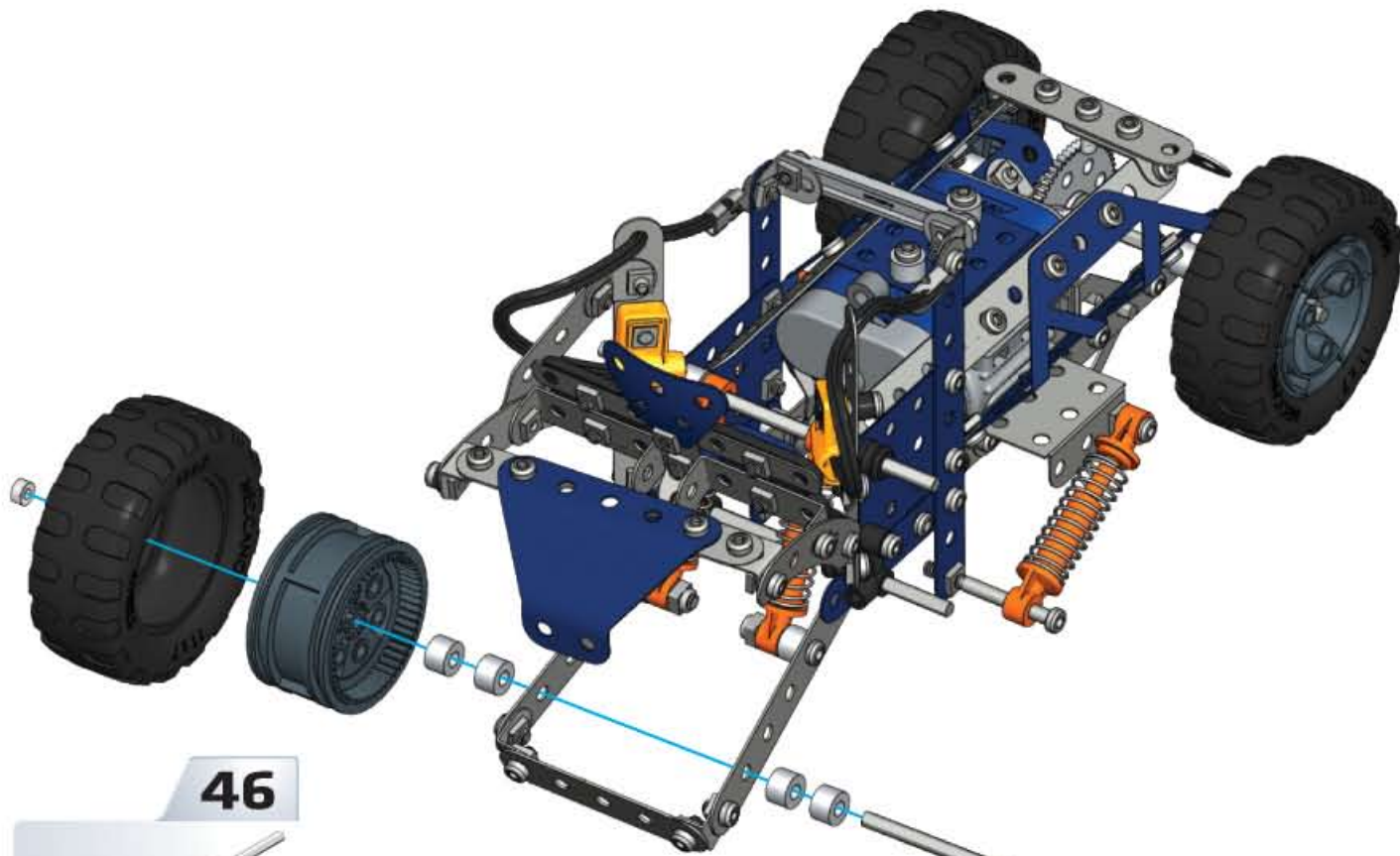

46

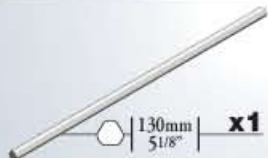

130mm
5 1/8" x1



x2



x2



x4



x2



1:1

**GB/USA**

Disposal of electric appliances at the end of their life (applicable in the countries of the European Union and other countries with a system of selective waste collection).

This symbol, placed on the product or its packaging, indicates that this product must not be disposed of with the household waste. It must be handed over at an appropriate collection point for the recycling of electric and electronic appliances. By ensuring that this product is disposed of in an appropriate manner, you will be helping prevent the potentially negative consequences on the environment. The recycling of the materials will help conserve natural resources. For any additional information on the subject of recycling this product, please consult your local authorities, your waste collection centre or the shop where you purchased the product.

When replacing your used batteries, we ask that you observe the regulations in force regarding their disposal. Thank you for depositing them at the place provided to that effect in order to ensure that they are disposed of in a safe manner and the environment is respected.

F

Traitement des appareils électriques et électroniques en fin de vie (applicable dans les pays de l'Union européenne et aux autres pays européens disposant de système de collecte sélective).

Ce symbole, apposé sur le produit ou son emballage, indique que ce produit ne doit pas être traité avec les déchets ménagers. Il doit être remis à un point de collecte approprié pour le recyclage des équipements électriques et électroniques. En s'assurant que ce produit est bien mis au rebut de manière appropriée, vous aiderez à prévenir les conséquences négatives potentielles pour l'environnement et la santé humaine. Le recyclage des matériaux aidera à conserver les ressources naturelles. Pour toute information supplémentaire au sujet du recyclage de ce produit, vous pouvez consulter votre municipalité, votre déchetterie ou le magasin où vous avez acheté le produit.

Lors du remplacement de vos piles usagées, nous vous demandons de suivre la réglementation en vigueur quant à leur élimination. Nous vous remercions de les déposer à un endroit prévu à cet effet afin d'en assurer leur élimination de façon sûre et dans le respect de l'environnement.

D

Verwertung von Elektrogeräten und elektronischen Geräten am Ende ihrer Lebensdauer (gilt in den Ländern der Europäischen Union und in anderen Ländern mit Mülltrennung).

Dieses Symbol auf dem Produkt oder auf der Verpackung bedeutet, dass das Produkt nicht über den Hausmüll entsorgt werden darf. Es muss bei einer geeigneten Sammelstelle für die Wiederverwertung von elektrischen und elektronischen Apparaten abgegeben werden. Indem Sie dafür sorgen, dass das Produkt einer angemessenen Entsorgung zugeführt wird, tragen Sie zur Vermeidung möglicher negativer Auswirkungen auf Umwelt und Gesundheit bei. Die Wiederverwertung von Materialien trägt zur Bewahrung der natürlichen Ressourcen bei. Weiterführende Informationen zur Wiederverwertung dieses Produkts bekommen Sie bei Ihrer Gemeinde- oder Stadtverwaltung, Ihrem Wertstoffhof oder in dem Geschäft, in dem Sie das Produkt gekauft haben.

Wir fordern Sie auf, sich beim Austausch leerer Batterien an die geltenden Vorschriften zu Ihrer Entsorgung zu halten. Bringen Sie sie bitte zu einer dafür vorgesehenen Stelle, damit sie sicher und umweltfreundlich entsorgt werden.

I

Trattamento delle apparecchiature elettriche ed elettroniche a fine vita (applicabile nei paesi dell'Unione europea e negli altri paesi europei con sistema di raccolta differenziata).

Questo simbolo, apposto sul prodotto o sul relativo imballo, indica che il prodotto non deve essere smaltito con i rifiuti domestici. Deve essere conferito presso un punto di raccolta appropriato per il riciclaggio delle apparecchiature elettriche ed elettroniche. Assicurandosi che questo prodotto venga smaltito in modo idoneo, l'utente contribuirà a evitare le potenziali conseguenze negative per l'ambiente e la salute umana. Il riciclaggio dei materiali contribuirà alla preservazione delle risorse naturali. Per ulteriori informazioni sul riciclaggio di questo prodotto rivolgersi presso il proprio comune, la discarica pubblica o il negozio in cui è stato effettuato l'acquisto.

Per la sostituzione delle batterie esaurite si richiede di attenersi alle normative in vigore relative allo smaltimento. Conferirle presso un luogo adibito a tale scopo al fine di assicurarne lo smaltimento in sicurezza e nel rispetto dell'ambiente.

E

Tratamiento de los aparatos eléctricos y electrónicos al final de su vida útil (aplicable en los países de la Unión Europea y en los países europeos que cuenten con un sistema de recogida selectiva de residuos).

Este símbolo estampado sobre el producto o su embalaje indica que, cuando finalice su vida útil, el aparato no deberá ser eliminado con los residuos domésticos. Deberá entregarse en el punto de recogida adecuado para el reciclado de los equipos eléctricos y electrónicos. Al hacer lo necesario para garantizar que este producto se deshecha correctamente, ayuda a prevenir las consecuencias negativas para el medio ambiente y la salud humana que podría causar la gestión inadecuada de este tipo de residuos. El reciclado de sus materiales contribuirá a proteger los recursos naturales. Si desea más información sobre el reciclado de este producto, póngase en contacto con su ayuntamiento, el punto de recogida más cercano o la tienda donde adquirió el aparato.

Cuando cambie las pilas usadas, respete la normativa vigente en materia de eliminación de las mismas. Gracias por depositarlas en un lugar previsto a tal efecto para garantizar que se eliminan de forma segura y respetando el medio ambiente.

P

Tratamento dos aparelhos elétricos e eletrônicos em fim de vida (aplicável nos países da União Europeia e nos outros países europeus que disponham de sistema de recolha seletiva).

Este símbolo, afixado no produto ou na respetiva embalagem, indica que este produto não deve ser tratado juntamente com os resíduos domésticos. Deve ser entregue num ponto de recolha apropriado para a reciclagem dos equipamentos elétricos e eletrónicos. Ao garantir que este produto é eliminado de forma apropriada, ajudará a prevenir as potenciais consequências negativas para o ambiente e a saúde humana. A reciclagem dos materiais ajudará a conservar os recursos naturais. Para qualquer informação suplementar a respeito da reciclagem deste produto, pode consultar o seu município, a sua estação de tratamento de resíduos ou a loja onde comprou o produto.

No momento da substituição das suas pilhas usadas, pedimos que siga a regulamentação em vigor quanto à respetiva eliminação. Agradecemos que as coloque num local previsto para o efeito de modo a garantir que a eliminação é feita de forma segura e com respeito pelo ambiente.

S

Behandling av förbrukade elektriska och elektroniska apparater (gäller i EU-länderna och i övriga europeiska länder som tillämpar separat sophämtning).

Den här symbolen som finns på produkten eller dess förpackning anger att denna produkt inte ska slängas med vanligt hushållsavfall. Den ska lämnas in till en lämplig insamlingsstation för återvinning av sina elektriska och elektroniska komponenter. Genom att försäkra dig om att den här produkten kasseras på rätt sätt bidrar du till att förhindra möjliga negativa konsekvenser för miljön och människors hälsa. Återvinning av material bidrar dessutom till att bevara naturresurserna. Om du behöver mer information om hur du ska återvinna den här produkten kan du rådfråga din kommun, din lokala sopstation eller den affär där du köpte produkten.

När du byter ut förbrukade batterier ber vi dig att du följer gällande föreskrifter för hur de ska kasseras. Vi uppskattar att du slänger dem på en för föremålet avsedd plats så att de kasseras på ett säkert och miljövänligt sätt.

FIN

Käytöstä poistettujen sähkö- ja elektronisten laitteiden käsittely (voimassa Euroopan Unionin jäsenvaltioissa ja muissa eurooppalaisissa maissa, jotka käyttävät jätteiden keräysjärjestelmää).

Tuotteeseen tai pakkaukseen merkitty symboli ilmaisee, että tätä tuotetta ei saa käsitellä talousjätteenä. Tuote on sen sijaan luovutettava sopivaan sähkö- ja elektroniikkalaitteiden kierrätyksestä huolehtivaan keräyspisteeseen. Tämän tuotteen asianmukaisen hävittämisen varmistamisella autetaan estämään sen mahdolliset ympäristöön ja terveyteen kohdistuvat haittavaikutukset. Materiaalien kierrätys säästää luonnonvaroja. Tarkempia tietoja tämän tuotteen kierrätyksestä saat paikallisesta kunnantoimistosta, kierrätyskeskuksesta tai jälleenmyyjältäsi.

Kun poistat tuotteesta käytetyt paristot tai akut, hävitä ne voimassa olevien säännösten mukaisesti. Vie käytetyt paristot ja akut niille tarkoitettuun keräyspisteeseen, jossa ne hävitetään asianmukaisella tavalla ympäristöä säästäen.

DK

Behandling af elektriske og elektroniske apparater ved slutningen af deres brugstid (gældende i EU-lande og andre europæiske lande, der råder over et selektivt indsamlingsystem).

Dette symbol, der sidder på produktet eller dets emballage, angiver, at produktet ikke må bortkastes sammen med husholdningsaffaldet. Det skal indleveres på et indsamlingssted beregnet til genbrug af elektrisk og elektronisk udstyr. Når du sørger for, at dette produkt indleveres det rigtige sted ved slutningen af dets levetid, er du medvirkende til at forhindre de negative potentielle virkninger på miljøet og sundheden. Genbrug af materialer er medvirkende til at bevare de naturlige ressourcer. For yderligere oplysninger om genbrug af dette produkt, bedes du tage kontakt til din kommune, genbrugspladsen eller butikken, hvor du har købt produktet.

Ved udskiftning af de brugte batterier, bedes du følge de gældende bestemmelser med hensyn til deres bortskaffelse. Tak, fordi du afleverer dem på et sted beregnet hertil for at sikre, at de bliver tilintetgjort på en sikker og miljøvenlig måde.

NL

Behandeling van elektrische en elektronische apparaten op het einde van hun levensduur (van toepassing in de E.U. en in de andere Europese landen die een systeem voor selectieve inzameling hanteren).

Dit symbool, dat op het product of op de verpakking staat, toont aan dat het product niet als huishoudafval mag worden behandeld. Breng het product naar het geschikte inzamelpunt voor recycling van elektrische en elektronische toestellen. Door ervoor te zorgen dat dit product op de geschikte manier wordt verwijderd, helpt u de mogelijke schadelijke gevolgen voor milieu en mens te voorkomen. Recycling van materiaal draagt bij tot het behoud van de natuurlijke hulpbronnen. Voor extra informatie over de recycling van dit product kunt u terecht bij uw gemeente, uw milieupark of de winkel waar u het product heeft gekocht.

Wat het vervangen van de batterijen betreft, vragen we u de geldende regelgeving te volgen die van kracht is op het ogenblik dat u ze verwijderd. We bedanken u alvast om deze op de daartoe voorziene plaats te deponeren zodat deze zeker op een veilige en milieuvriendelijke manier worden verwijderd.

GR

Επεξεργασία των ηλεκτρικών και ηλεκτρονικών συσκευών στο τέλος κύκλου ζωής τους (εφαρμοστέο στις χώρες της Ευρωπαϊκής Ένωσης και στις άλλες ευρωπαϊκές χώρες που διαθέτουν σύστημα επιλεκτικής συλλογής).

Το σύμβολο αυτό, αναγραφόμενο επάνω στο προϊόν ή στη συσκευασία του, σημαίνει ότι το προϊόν αυτό δεν πρέπει να απομακρυνθεί μαζί με τα οικιακά απόβλητα. Πρέπει να παραδοθεί σε ένα κατάλληλο σημείο συλλογής για την ανακύκλωση των ηλεκτρικών και ηλεκτρονικών συσκευών. Διασφαλίζοντας ότι το προϊόν αυτό θα απομακρυνθεί κατάλληλα, βοηθάτε στην πρόληψη των ενδεχόμενων αρνητικών επιπτώσεων για το περιβάλλον και την ανθρώπινη υγεία. Η ανακύκλωση των υλικών θα βοηθήσει στη διατήρηση των φυσικών πόρων. Για κάθε πρόσθετη πληροφορία σχετικά με την ανακύκλωση του προϊόντος αυτού, μιλήστε με επικοινωνήστε με το Δήμο σας, την εταιρεία αποκομιδής αποβλήτων ή το κατάστημα όπου αγοράσατε το προϊόν.

Όταν αντικαθιστάτε τις μπαταρίες, παρακαλείσθε να τηρείτε την ισχύουσα νομοθεσία σχετικά με την απομάκρυνσή τους. Σας ευχαριστούμε που τις εναποθέτετε στα προβλεπόμενα σημεία συλλογής ούτως ώστε να απομακρυνθούν με ασφάλεια και με σεβασμό για το περιβάλλον.

BULGARIAN

Третиране на излезлите от употреба електрически и електронни уреди (приложимо за всички страни от Европейския съюз и за останалите европейски страни, които разполагат със система за разделно събиране на отпадъците).

Този поставен върху продукта или опаковката му символ показва, че този продукт не трябва да бъде третиран заедно с битовите отпадъци. Той трябва да бъде оставен в подходящ събирателен пункт за рециклиране на електрическо и електронно оборудване. Като осигурите правилното изхвърляне на този продукт, Вие ще спомогнете за предотвратяването на възможните вредни въздействия върху околната среда и човешкото здраве. Рециклирането на материалите ще спомогне за опазването на природните ресурси. За повече информация относно рециклирането на този продукт можете да се обърнете към Вашата община, Вашия предавателен пункт или магазина, в който сте купили продукта. При смяна на употребените батерии Ви молим да спазвате действащото законодателство по отношение на тяхното изхвърляне. Ако обичате, изхвърлете ги на предвидено за тази цел място, за да може те да бъдат обезвредени по сигурен и щадящ околната среда начин.

CZECH

Likvidace elektrických spotřebičů na konci jejich životnosti (platí v zemích Evropské unie a dalších zemích se systémem sběru tříděného odpadu).

Tento symbol umístěný na výrobku nebo na jeho obalu indikuje, že výrobek nesmí být likvidován s domovním odpadem. Musí být předán na příslušné sběrné místo pro recyklaci elektrických a elektronických přístrojů. Zajištěním správné likvidace tohoto výrobku pomůžete předcházet potenciálním negativním dopadům na životní prostředí. Recyklace materiálů přispívá k uchování přírodních zdrojů. Další informace o likvidaci starého vybavení si laskavě vyžádejte od místních úřadů, podniku zabývajícího se likvidací komunálních odpadů nebo obchodu, kde jste výrobek zakoupili.

Při výměně použitých baterií vás prosíme, abyste respektovali platné předpisy týkající se jejich likvidace. Děkujeme vám za to, že je odložíte na místě k tomu určeném, abyste tak zajistili jejich bezpečnou likvidaci šetrnou k životnímu prostředí.

ESTONIAN

Elektri- ja elektroonikaseadmete jäätmete käitlemine (rakendatav Euroopa Liidu liikmesriikides ja teistes Euroopa riikides, kus on olemas sorteeritud jäätmete kogumissüsteem).

See sümbol tootel või pakendil näitab, et toode ei tohi käidelda koos olmejäätmetega. See tuleb toimetada elektri- ja elektroonikaseadmete kogumispunkti. Hooldisesed käesoleva toote nõuetekohase hävitamise eest, aitate ühtlasi ära hoida võimalikke negatiivseid tagajärgi keskkonnale ja inimeste tervisele. Materjalide taaskasutus aitab säästa loodusressursse. Täiendavat teavet käesoleva toote jäätmekäitluse kohta küsige kohalikest omavalitsusest, jäätmekäitlusega tegelevast ettevõttest või kauplusest, kust toote ostsite.

Patareide väljavahetamisel palume teil järgida kasutatud patareide kõrvaldamise kohalikke eeskirju. Täname nende viimise eest selleks ettenähtud kogumiskohta, et tagada nende ohutu ja keskkonda austav kõrvaldamine.

LITHUANIAN

Elektros prietaisų išmetimas pasibaigus jų naudojimui laikui (taikytina Europos Sąjungos ir kitoms šalims, kuriose naudojama atliekų rūšiavimo sistema).

Šis ženklas ant gaminio arba jo pakuotės reiškia, kad šio gaminio negalima išmesti kartu su buitineis atliekomis. Jį reikia atiduoti į atitinkamą atliekų surinkimo punktą, skirtą elektros ir elektronikos prietaisams surinkti ir perdirbti. Užtikrindami, kad šis gaminys būtų tinkamai išmestas, jūs padėsite saugoti aplinką nuo galimai neigiamų padarinių. Pakartotinis medžiagų panaudojimas padės tausoti gamtos išteklius. Papildomos informacijos apie šio gaminio perdirbimą gali suteikti vietos valdžios institucijos, buitinių atliekų surinkimo tarnyba arba parduotuvė, kurioje įsigijote šį gaminį.

Keičiant panaudotus mašinimo elementus, būtina laikytis galiojančių vietos taisyklių dėl jų išmetimo. Ačiū, kad išmetate juos tam skirtoje vietoje, siekdami užtikrinti, jog jie būtų surenkami saugiai, tausojant aplinką.

HUNGARIAN

Az elektromos készülékek hulladékra helyezése élettartamuk lejárta után (Az EU országain belül és más - a szelektív hulladékgyűjtés rendszerét alkalmazó - országokon belül alkalmazandó).

Ez a szimbólum a terméken vagy annak csomagolásán azt jelzi, hogy a terméket tilos a háztartási hulladékkal együtt helyezni hulladékra. A terméket át kell adni a megfelelő gyűjtőhelyen az elektromos és elektronikus berendezések újrahasznosítására céljából. A megfelelő elhelyezés biztosításával segít megelőzni az esetleges negatív környezeti ártalmak kialakulását. Az anyagok újrahasznosítása segít megővni a természeti erőforrásokat. Bármilyen további információért a termék újrahasznosítására vonatkozóan, kérjük, forduljon a helyi hatóságokhoz, a hulladékgyűjtési központhoz vagy az üzlethez, ahol a terméket vásárolta.

A használt elemek kicserélésakor, arra kérjük, hogy tartsa be a hatályos vonatkozó rendelkezéseket. Köszönjük, hogy a kijelölt pontban helyezte azokat hulladékra, elősegítve, hogy azok ártalmatlanítása biztonságos módon és a környezet tisztéletben tartásával történjen.

MALTESE

Ir-rimi ta' apparat tal-elettriku li jkun wasal fit-tmiem tal-hajja tiegħu (applikabbli fil-pajjiżi tal-Unjoni Ewropea u f'pajjiżi oħrajn b'sistema ta' ġbir ta' skart selettiv).

Dan is-simbolu, impoġġi fuq il-prodott jew fuq l-imballaġġ tiegħu, jindika li dan il-prodott ma għandux jintrema mal-iskart domestiku. Għandu jiġi ppreżentat f'punt ta' ġbir adegwat għar-riċiklaġġ ta' apparat tal-elettriku u elettroniku. Billi jiġi żgurat li dan il-prodott jintrema bil-mod ix-xieraq, inti tkun qed tgħin fil-prevenzjoni ta' konsegwenzi potenzjalment negattivi fuq l-ambjent. Ir-riċiklaġġ tal-materjali se jgħin fil-konservazzjoni tar-riżorsi naturali. Għal kwalunkwe informazzjoni addizzjonali dwar is-suġġett tar-riċiklaġġ ta' dan il-prodott, jekk jogħġbok ikkonsulta lill-awtoritajiet lokali tiegħek, liċ-ċentru ta' ġbir ta' skart jew lill-hanut minn fejn xtrajt il-prodott.

Meta tissostitwixxi l-batteriji użati tiegħek, ahna nitolbuk li tisserva r-regolamenti fis-seħh dwar ir-rimi tagħhom. Grazzi talli tarnihom fil-post ipprovdut għal dan il-għan sabiex jintremew b'mod sikur u l-ambjent jiġi rrispettat.

POLISH

Pozbycie się zużytego sprzętu elektrycznego i elektronicznego (stosowane w krajach Unii Europejskiej i innych krajach europejskich posiadających systemy zbiórki selektywnej).

Symbol ten, umieszczony na produkcie lub jego opakowaniu, wskazuje, że produkt ten nie powinien być usuwany wraz z odpadami komunalnymi, lecz złożony w odpowiednim punkcie zbiórki zużytego sprzętu elektrycznego i elektronicznego. Upewniając się, że produkt ten jest prawidłowo usunięty, zapobiegasz potencjalnym negatywnym skutkom dla środowiska naturalnego i zdrowia ludzkiego. Recykling materiałów pomaga zachować zasoby naturalne. Aby uzyskać szczegółowe informacje dotyczące recyklingu tego produktu, należy skontaktować się z urzędem miasta lub gminy, punktem zbiórki lub sklepem, w którym dokonano zakupu produktu.

Podczas wymiany zużytych baterii prosimy zastosować się do obowiązujących przepisów dotyczących ich usuwania. Prosimy o złożenie ich w przeznaczonym do tego celu miejscu, aby zapewnić ich bezpieczne usunięcie, niezagrożające środowisku naturalnemu.

ROMANIAN

Evacuarea echipamentelor electrice la finalul duratei de utilizare (aplicabilă în țările Uniunii Europene și în alte țări care dispun de un sistem de colectare selectivă a deșeurilor).

Acest simbol, aplicat pe produs sau pe ambalajul acestuia, indică faptul că acest produs nu trebuie eliminat împreună cu deșeurile menajere. Acesta trebuie predat unui centru corespunzător de colectare în vederea reciclării echipamentelor electrice și electronice. Asigurându-vă că acest produs este eliminat în mod adecvat, veți contribui la prevenirea posibilelor consecințe negative asupra mediului înconjurător. Prin reciclarea materialelor, veți ajuta la conservarea resurselor naturale. Pentru orice informații suplimentare cu privire la reciclarea acestui produs, vă rugăm să consultați centrul local de reciclare sau magazinul de unde ați achiziționat produsul. Când înlocuiți bateriile uzate, vă rugăm să respectați regulamentele în vigoare, referitoare la eliminarea acestora. Vă mulțumim că le predați unui centru special pentru a vă asigura că sunt eliminate în siguranță și respectând mediul înconjurător.

SLOVAK

Spracovanie elektrických a elektronických zariadení na konci životnosti (platné v krajinách Európskej únie a európskych krajinách, ktoré disponujú systémom selektívneho zberu).

Tento symbol na výrobku alebo jeho obale informuje, že tento produkt nesmie byť spracovaný s odpadom z domácností. Je potrebné ho odovzdať na zbernom mieste určenom pre recykláciu elektrických a elektronických zariadení. Tým, že tento výrobok odstránite náležitým spôsobom, dopomôžete tak zabráneniu možných negatívnych vplyvov na životné prostredie a zdravie ľudí. Recyklácia materiálov napomáha zachovávaníu prírodných zdrojov. V prípade akékoľvek otázky týkajúcej sa recyklácie tohto výrobku môžete kontaktovať svoj mestský úrad, spoločnosť, ktorá zabezpečuje odvoz odpadu alebo predajňu, v ktorej ste tento výrobok kúpili.

Pri výmene opotrebovaných batérií vás žiadame o dodržanie platných zákonných nariadení týkajúcich sa ich odstraňovania. Odovzdajte ich prosím na mieste, ktoré je určené pre tento účel, čím zabezpečíte ich bezpečné a pre životné prostredie neškodné odstránenie.

SLOVENIAN

Odstranjevanje električne in elektronske opreme ob koncu njene življenjske dobe (velja v državah Evropske unije in drugih evropskih državah, kjer je v veljavi ločeno zbiranje odpadkov).

Ta simbol na izdelku ali njegovi embalaži označuje, da se izdelka ne sme odložiti med gospodinjске odpadke. Odložiti ga je treba na zbirno mesto za recikliranje električne in elektronske opreme. Če izdelek ustrezno zavržete, s tem pomagate preprečevati morebitne negativne posledice za okolje in zdravje ljudi. Recikliranje materialov pripomore k ohranjanju naravnih virov. Nadaljnje informacije v zvezi z recikliranjem tega izdelka so na voljo v vaši občini, na deponiji odpadkov ali v trgovini, kjer ste izdelek kupili.

Pri menjavi baterij upoštevajte veljavne predpise o njihovem odlaganju. Zahvaljujemo se vam za uporabo predvidenih zbiralnikov za odpadne baterije, saj tako zagotovite uničenje baterij na varen način, ki spoštuje okolje.

IRISH

Díúscairt fearas leictreacha ag deireadh a saoil (infheidhmíthe i dtíortha an Aontais Eorpaigh agus i dtíortha eile ina bhfuil córas de bhailiú roghnadh dramhaíola).

Tugann an siombal seo, a chuirtear ar an táirge ná ar an bpacáistiú ag gobháil leis, le fios nach ceart an táirge seo a dhíúscairt le dramhaíl an teaghlaigh. Ní mór é a thabhairt suas ag ionad cuí bailithe ina ndéantar fearais leictreacha is leictreonacha a athchúrsáil. Trí chinntiú go ndéantar an táirge seo a dhíúscairt ar mhodh cuí, beidh tú ag cabhrú chun iarmhairtí diúltacha ar an timpeallacht a sheachaint. Cabhróidh athchúrsáil an ábhair chun acmhainní nádúrtha a choomhnú. Chun aon eolas breise a fháil faoi athchúrsáil an táirge seo, déan teagmháil más é do thoil é le d'údarás áitiúil, d'ionad bailithe dramhaíola nó leis an siopa inar cheannaigh tú an táirge.

Agus na cadhnraí caite á gcaitheamh uait, iarrann muid ort cloí leis na rialacháin atá i bhfeidhm faoina ndíúscairt. Go raibh maith agat as iad a dhíúscairt ag an áit a cuireadh ar fáil le haghaidh sin chun a chinntiú go ndéantar iad a dhíúscairt ar mhodh sábháilte agus go dtugtar urraim don timpeallacht.

LATVIAN

Atbrīvošanās no elektriskām ierīcēm, kuras vairs netiek izmantotas (attiecas uz Eiropas Savienības valstīm un citām valstīm, kurās pastāv selektīva atkritumu savākšanas sistēma).

Šis simbols, kas atrodas uz ražojuma vai tā iepakojuma, norāda, ka šo ražojumu nedrīkst izmest kopā ar sadzīves atkritumiem. Tas jānodod īpašā pārstrādāšanai paredzēto elektrisko un elektronisko ierīču savākšanas punktā. Nodrošinot, ka šis ražojums tiek iznīcināts atbilstīgā veidā, jūs palīdzēsiet novērst iespējamo negatīvo ietekmi uz vidi. Materiālu pārstrāde palīdz saglabāt dabas resursus. Lai iegūtu papildu informāciju par šī ražojuma pārstrādi, lūdzam, sazinieties ar vietējām varas iestādēm, tuvāko atkritumu savākšanas centru vai veikalu, kurā jūs iegādājāties šo ražojumu.

Nomainot izlietotās baterijas, lūdzam, ievērojiet spēkā esošos noteikumus par to iznīcināšanu. Lūdzam, novietojiet tās šim nolūkam paredzētajā vietā, lai nodrošinātu to, ka to iznīcināšana notiek droši un ka tiek ievēroti ar vides aizsardzību saistītie apsvērumi.

GB Remove all packaging before use. Retain this information, addresses and phone numbers for future reference. Content may vary from pictures. Meccano reserves the right to discontinue the website www.meccano.com at any time. An adult should periodically check this toy to ensure no damage or hazard exist if so, remove from use. Children should be supervised during play.

F Retirer tout l'emballage avant utilisation. Conserver les informations, adresses et numéros de téléphone pour consultation ultérieure. Le contenu peut différer des images. Meccano se réserve le droit de supprimer le site Internet www.meccano.fr à tout moment. Un adulte doit régulièrement examiner ce jouet afin de s'assurer qu'il ne présente pas de dommage ni de risque. En cas de problème, ne plus l'utiliser. Les enfants doivent être surveillés lorsqu'ils jouent.

E Retire todo el embalaje antes de utilizar el producto. Conserve toda la información, las direcciones y los números de teléfono para futuras referencias. El contenido del paquete puede no corresponder con las imágenes. Meccano se reserva el derecho a suspender el sitio web www.meccano.com en cualquier momento. Un adulto debe revisar de forma periódica el juguete para asegurarse de que no supone un riesgo o peligro para el niño; si así fuera el caso, interrumpa su uso. Supervise a los niños mientras juegan con el producto.

D Entfernen Sie vor der Benutzung sämtliche Verpackungsmaterialien. Alle Informationen, Adressen und Telefonnummern bitte für mögliche Rückfragen aufbewahren. Der Packungsinhalt kann von den Bildern abweichen. Meccano behält sich das Recht vor, den Betrieb der Website www.meccano.com jederzeit einzustellen. Ein Erwachsener sollte regelmäßig sicherstellen, dass das Spielzeug keine Gefahr darstellt, und es gegebenenfalls entfernen. Kinder sollten beim Spielen beaufsichtigt werden.

GB ⚠ CAUTION: Stickers not intended to be placed on skin.

F ⚠ MISE EN GARDE : Les autocollants ne sont pas destinés à être placés sur la peau.

E ⚠ PRECAUCIÓN: Las calcomanías no deben colocarse sobre la piel.

D ⚠ ACHTUNG: Sticker sind nicht zum Aufkleben auf die Haut geeignet.

NL ⚠ VOORZICHTIG: Stickers zijn niet voor op de huid bedoeld.

I ⚠ ATTENZIONE: Non applicare gli adesivi sulla pelle.

P ⚠ ATENÇÃO: os autocolantes não devem ser colocados na pele.

GR ⚠ ΠΡΟΣΟΧΗ: Μην κολλάτε τα αυτοκόλλητα στο δέρμα σας.

S ⚠ VARNING: Klistermärkena bör inte sättas på huden.

DK ⚠ ADVARSEL: Klistermærker er ikke beregnet til at sætte på huden.

FIN ⚠ VAROITUS: Tarjoja ei saa kiinnittää ihoon.

RU ⚠ ОСТОРОЖНО: Стикеры не предназначены для приклеивания к коже.

NL Verwijder de verpakking voor gebruik. Bewaar deze informatie, adressen en telefoonnummers voor toekomstig gebruik. Inhoud kan afwijken van illustraties. Meccano behoudt zich het recht voor de website www.meccano.com wanneer gewenst buiten gebruik te stellen. Een volwassene dient dit speelgoed regelmatig te controleren op schade en gevaren. Indien het speelgoed is beschadigd of indien er een gevaarlijke situatie kan ontstaan, dient het product te worden weggegooid. Ouderlijk toezicht is vereist als kinderen met dit speelgoed spelen.

I Rimuovere l'imballaggio prima dell'uso. Conservare informazioni, indirizzi e numeri di telefono per riferimento futuro. Il prodotto potrebbe differire dalle immagini. Meccano si riserva il diritto di rimuovere il sito www.meccano.com in qualsiasi momento. È consigliabile un controllo periodico del giocattolo da parte di un adulto: in caso di danni o rischi interrompere l'uso. È richiesta la supervisione di un adulto durante il gioco.

P Remova totalmente a embalagem antes de utilizar. Guarde estas informações, as moradas e os números de telefone para consulta futura. O conteúdo poderá ser diferente das ilustrações. A Meccano reserva-se o direito de descontinuar o sítio www.meccano.com a qualquer altura. Um adulto deve verificar o brinquedo periodicamente para garantir que não ele não apresenta danos ou riscos. Se houver, é necessário que o brinquedo seja retirado de uso. Crianças devem ser supervisionadas enquanto brincam.

GR Πριν την χρήση αφαιρέστε όλα τα υλικά της συσκευασίας. Διατηρήστε αυτές τις πληροφορίες, τις διευθύνσεις και τους αριθμούς τηλεφώνου για μελλοντική αναφορά. Το περιεχόμενο ενδέχεται να διαφέρει από τις εικόνες. Η Meccano διατηρεί το δικαίωμα να διακόψει τη λειτουργία της τοποθεσίας www.meccano.com ανά πάσα στιγμή. Ένας ενήλικας θα πρέπει να εξετάζει τακτικά αυτό το παιχνίδι και να διακόπτει τη χρήση του σε περίπτωση εντοπισμού βλαβών ή κινδύνων. Τα παιδιά θα πρέπει να παίζουν υπό επίτηρηση.

GB ⚠ Warning! CHOKING HAZARD - Small parts.

F ⚠ Attention ! RISQUE D'ÉTOUFFEMENT - Contient de petits éléments.

E ⚠ Advertencia: PELIGRO DE ASFIXIA - Contiene piezas pequeñas. No conveniente para niños menores de 3 años.

D ⚠ Achtung: ERSTICKUNGSGEFAHR - Kleinteile.

NL ⚠ Waarschuwing: VERSTIKKINGSGEVAAR - Kleine onderdelen.

I ⚠ Attenzione: RISCHIO DI SOFFOCAMENTO - Pezzi piccoli.

P ⚠ Aviso: PERIGO DE ASFIXIA - Peças pequenas.

GR ⚠ Προειδοποίηση: ΚΙΝΔΥΝΟΣ ΠΝΙΓΜΟΥ — Μικρά μέρη.

S ⚠ Varning: RISK FÖR KVÄVNING - Små delar.

DK ⚠ Advarsel: KVAELNINGSFARE - Små dele.

FIN ⚠ Varoitus: TUKEHTUMISVAARA - Pieniä osia.

RU ⚠ Осторожно! ОПАСНОСТЬ УДУШЬЯ - мелкие детали.

S Ta bort alla förpackningar före användning. Spara den här informationen, adresser och telefonnummer för framtida referens. Innehållet kan skilja sig från bilderna. Meccano förbehåller sig rätten att när som helst ta bort webbplatsen www.meccano.com. En vuxen ska regelbundet undersöka den här leksaken för att säkerställa att det inte finns några skador eller faror rörande den. Om det finns några ska den inte användas längre. Håll borta från hinder och elektriska risker.

DK Fjern al emballage før brug. Gem disse oplysninger, adresser og telefonnumre for fremtidig brug. Indholdet kan være forskelligt fra billederne. Meccano forbeholder sig ret til at nedlægge hjemmesiden www.meccano.com til enhver tid. En voksen bør med jævne mellemrum undersøge leken for å se om den er skadet, eller om det foreligger noen fare. Hvis det er tilfellet, må leken ikke lenger brukes. Bam bør holdes under oppsyn når de leker.

FIN Poista kaikki pakkausmateriaali ennen käyttöä. Säilytä nämä tiedot, osoitteet ja puhelinnumerot tulevia tarpeita varten. Sisältö saattaa poiketa kuvista. Meccano pidättää oikeuden lakkauttaa sivuston www.meccano.com milloin tahansa. Aikuisen tulee säännöllisesti tarkistaa, että lelu ei ole vaurioitunut ja muuttunut vaaralliseksi. Jos näin on käynyt, lelu tulee poistaa käytöstä. Lasten tulee leikkiä vain aikuisen valvonnassa.

RU Снимите все упаковочные материалы перед использованием. Запишите указанные на упаковке адреса и номера телефонов, чтобы у вас была возможность связаться с нами. Содержимое упаковки может отличаться от иллюстрации. Компания Meccano оставляет за собой право прекратить использование сайта www.meccano.com в любое время. Регулярно проверяйте состояние игрушки на наличие повреждений и возможных рисков для ребенка. Если таковые имеются, игрушку не следует использовать. Во время игры за детьми следует присматривать.



© 04 /2014 MECCANO for packaging, instructions and models built with this set. © 04/2014 MECCANO pour l'emballage, les notices et modèles de ce coffret. © MECCANO is an exclusive trademark of MECCANO. Spin Master logo is a trademark of Spin Master Ltd. © MECCANO est une marque de commerce exclusive de MECCANO. Le logo de Spin Master est une marque de commerce de Spin Master Ltd. All rights reserved. Tous droits réservés.



UK – 0800 206 1191, SERVICEUK@SPINMASTER.COM
FRANCE – 0800 909 150, SERVICEFR@SPINMASTER.COM
ESPAÑA – SERVICIO@SPINMASTER.COM
DEUTSCHLAND – 0800 0101 0222, KUNDENSERVICE@SPINMASTER.COM
SCHWEIZ – 0800 561 350 • ÖSTERREICH – 0800 29 72 67
NEDERLAND – 0800 022 36 83, KLANTENSERVICE@SPINMASTER.COM
BELGIË/BELGIQUE – 0800 77 688 • LUXEMBOURG – 800 28 044
ITALIA – 800 788 532, SERVIZIO@SPINMASTER.COM
MEXICO – 53.51.44.00
WWW.SPINMASTER.COM

NORTH AMERICA : 1-800-622-8339 customer@spinmaster.com
AMÉRIQUE DU NORD :

SPIN MASTER LTD., 450 FRONT STREET WEST,
TORONTO, ON M5V 1B6 CANADA.
Imported into EU by SPIN MASTER INTERNATIONAL,
S.A.R.L., 16 AVENUE PASTEUR,
L-2310, LUXEMBOURG. www.spinmaster.com
Made in China for/ Fabriqué en Chine pour Meccano :
363, avenue de Saint-Exupéry 62100 Calais – France



T91680 0004 20067868 GML IB R1 W1

837555 104 111W1