

Instructions  
 Notice de montage  
 Bauanleitung  
 Istruzioni di montaggio  
 Instrucciones de montaje  
 Instruções de montagem  
 Monterinsanvisning  
 Kokoamisohje  
 Monterings instruktioner  
 Montagehandleiding  
 Οδηγίες συναρμολόγησης.  
 Инструкции

# MULTIMODELS

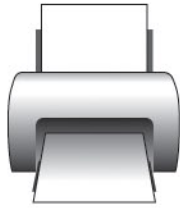

- FR Merci d'imprimer à échelle 1 sans les marges de l'imprimante.
- GB Please print at scale 1 without the printer margins.
- D Den Maßstab 1 bitte randlos drucken.
- IT Stampare la scala 1 senza i margini della stampante.
- E Imprimir a escala 1 sin los márgenes de la impresora.
- P É favor imprimir escala 1 sem as margens da impressora.
- S Skriv ut i skala 1 utan skrivarens marginaler.
- FIN Portaiden painatuksen jälkeen reunat eivät saa näkyä.
- DK Udskriv venligst i målestoksforhold 1 uden printermargener.
- NL É favor imprimir escala 1 sem as margens da impressora.
- GR Σας παρακαλώ τυπώστε την κλίμακα 1 μέσα στα περιθώρια του εκτυπωτή.
- R Пожалуйста, печатайте в масштабе 1:1 без отступов от края.

8+

3555



### 3 MODELS



### CONSTRUCTION TIPS

LES ASTUCES DE CONSTRUCTION  
 KONSTRUKTIONS-TIPPS  
 LE ASTUZIE DELLA COSTRUZIONE  
 LOS INGENIOS DE LA CONSTRUCCIÓN  
 DICAS PARA A MONTAGEM  
 KOKOONPANON KIKAT  
 BYGGKNEPEN  
 ET PAR TIPS TIL BYGGARBEJDET  
 DE FIJNE KNEEPJES VAN HET BOUWEN  
 Τα έξυπνα κόλπα κατασκευής  
 рекомендации по сборке

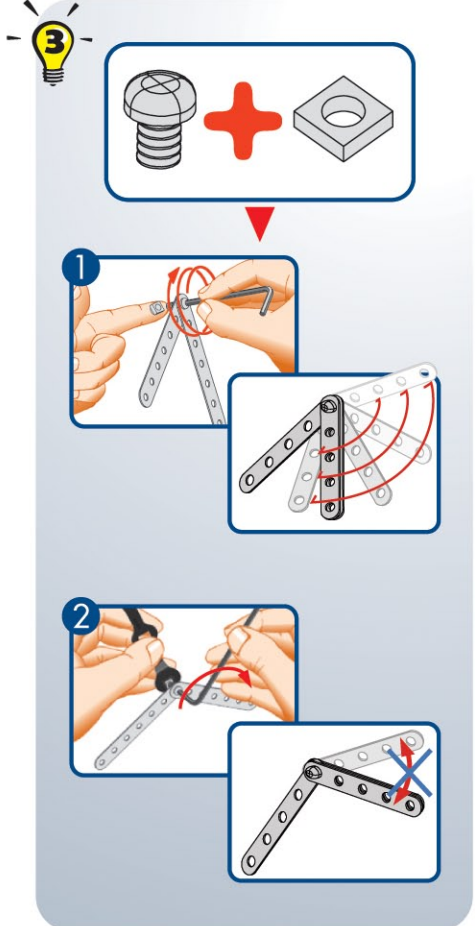
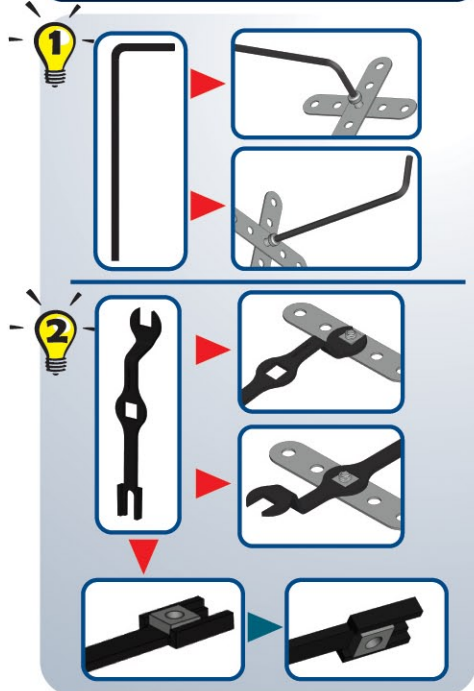

	<b>C472 x2</b>		<b>A302 (0002A) x1</b>
	<b>A127 (0126A) x1</b>		<b>A302 (0002A) x2</b>
	<b>A503 (0103L) x1</b>		<b>A203 (0003) x2</b>
	<b>A827 (0027FP) x1</b>		<b>A105 (0005) x1</b>
	<b>A242 (0142L) x4</b>		<b>A416 (0235G) x1</b>
	<b>A286 (0090) x2</b>		<b>A416 (0235G) x3</b>
	<b>A233 (0133C) x4</b>		<b>A806 (0806B) x1</b>
	<b>A713 (0012D) x2</b>		<b>A548 (0048E) x6</b>
	<b>A812 (0812B) x1</b>		<b>A825 (0825) x4</b>
	<b>A420 (0260C) x2</b>		<b>A811 (0811) x1</b>
			<b>A012 (0012) x1</b>

	<b>B2</b>	19mm 3/4"	<b>A447 (0147F) x1</b>
	<b>B1</b>	14,7mm 37/64"	<b>A247 (0147D) x4</b>
	<b>S3</b>	12mm 1/2"	<b>A411 (0111A) x6</b>
	<b>S2</b>	9,5mm 3/8"	<b>A511 (0111C) x1</b>
	<b>S1</b>	5,8mm 15/64"	<b>A637 (0037B) x30</b>
			<b>A138 (0038) x2</b>
			<b>A337 (0037A) x47</b>
			<b>A238 (0038A) x6</b>
			<b>A338 (0038B) x6</b>
			<b>A136 (0036C) x1</b>
			<b>C088 x1</b>



**1**

	<b>x1</b>	
	<b>x1</b>	
	5,8mm 15/64"	<b>x1</b>
	<b>x1</b>	

	<b>S1</b>	<b>1:1</b>
--	-----------	------------

⚠ Scale 1 Escala 1 Mittakaava 1  
Echelle 1 Schaal 1 Mälestok 1  
Maßstab 1 Escala 1 Καμάρια 1  
Scala 1 Skala 1 масштаб 1

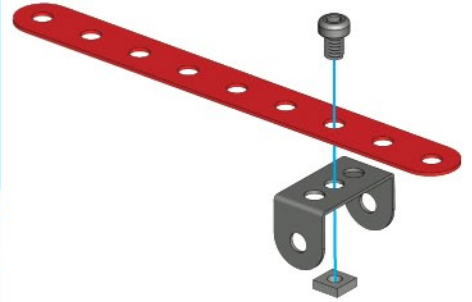

**2**

	<b>x1</b>	
	5,8mm 15/64"	<b>x1</b>
	<b>x1</b>	

	<b>S1</b>	<b>1:1</b>
--	-----------	------------

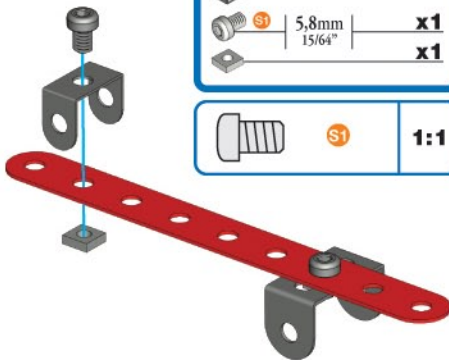

**3**

	<b>x1</b>	
	5,8mm 15/64"	<b>x2</b>
	<b>x2</b>	

	<b>S1</b>	<b>1:1</b>
--	-----------	------------

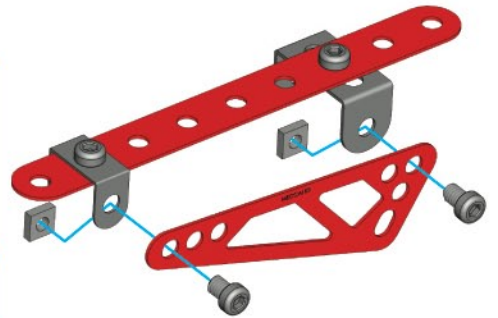

**4**

	<b>x1</b>	
	5,8mm 15/64"	<b>x2</b>
	<b>x2</b>	

	<b>S1</b>	<b>1:1</b>
--	-----------	------------

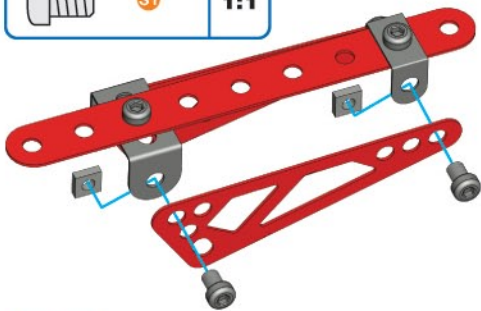

**5**

	<b>x1</b>	
	<b>x1</b>	
	5,8mm 15/64"	<b>x1</b>

	<b>S1</b>	<b>1:1</b>
--	-----------	------------

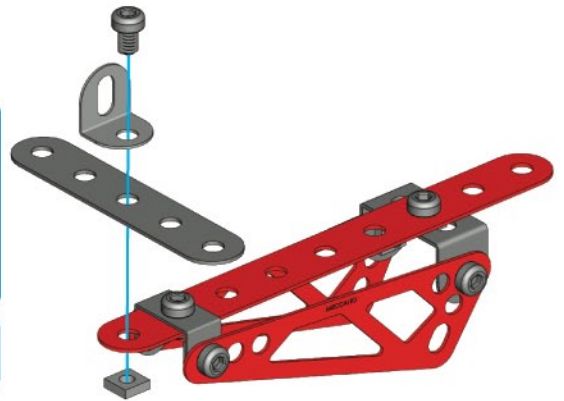

**6**

	<b>x1</b>	
	<b>x1</b>	
	5,8mm 15/64"	<b>x1</b>
	<b>x1</b>	

	<b>S1</b>	<b>1:1</b>
--	-----------	------------

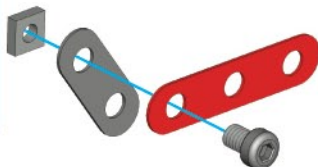

**7** (5)+(6)+

	<b>x1</b>	
	9,5mm 3/8"	<b>x1</b>
	<b>x1</b>	

	<b>S2</b>	<b>1:1</b>
--	-----------	------------

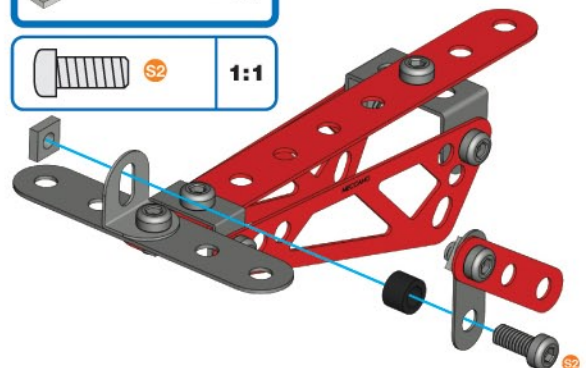

**8**

	x1
	x1
	x1
	x1

	1:1
--	-----



**9**

	x2
	x1
	x1

	1:1
--	-----

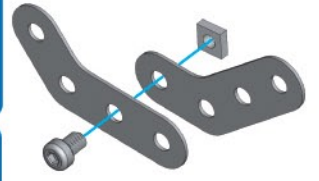

**10**

	x1
	x1
	x1
	x1
	x1

	1:1
--	-----

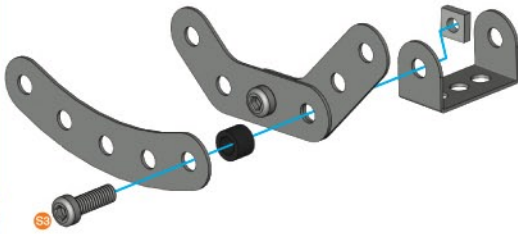

**11**

	x2
	x1
	x1

	1:1
--	-----

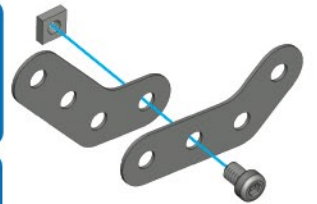

**12** (10) + (11) +

	x1
	x1
	x1
	x1
	x1

	1:1
--	-----

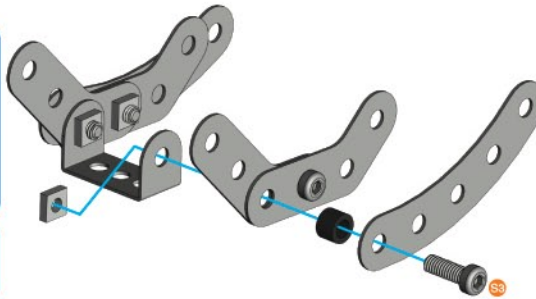

**13** (8) + (12) +

	x2
	x2

	1:1
--	-----

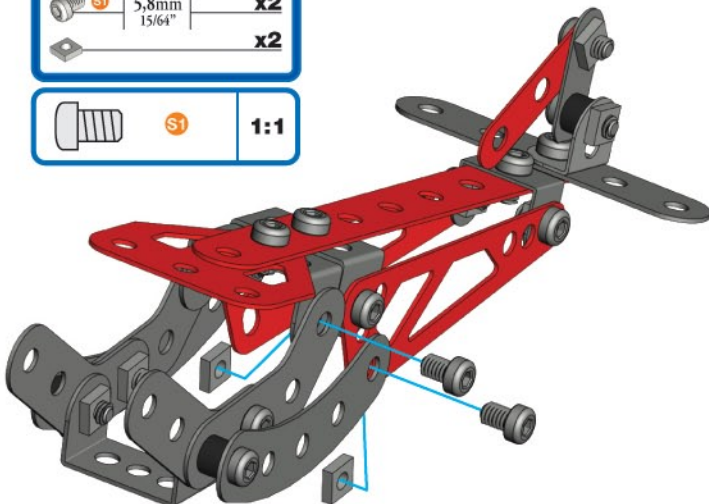

**14**

	x2
	x2

	1:1
--	-----

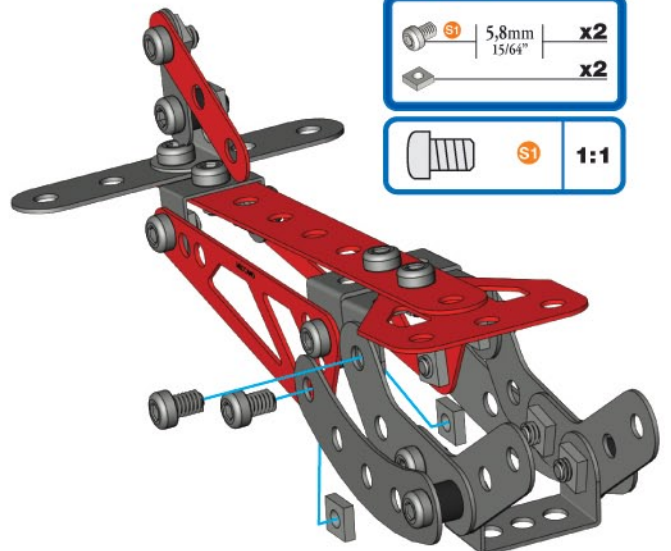

**15**

	x1
	x1
	x1
	x1

	1:1
--	-----

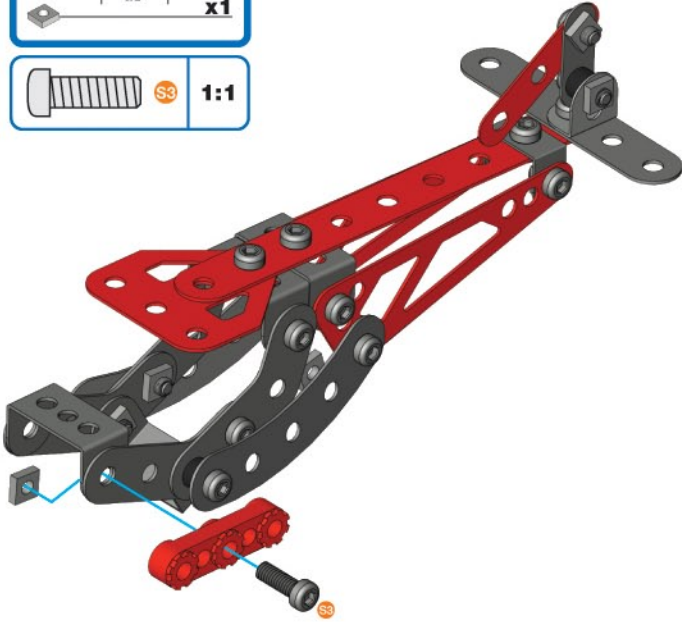
**16**

	x1
	x1
	x1

	1:1
--	-----

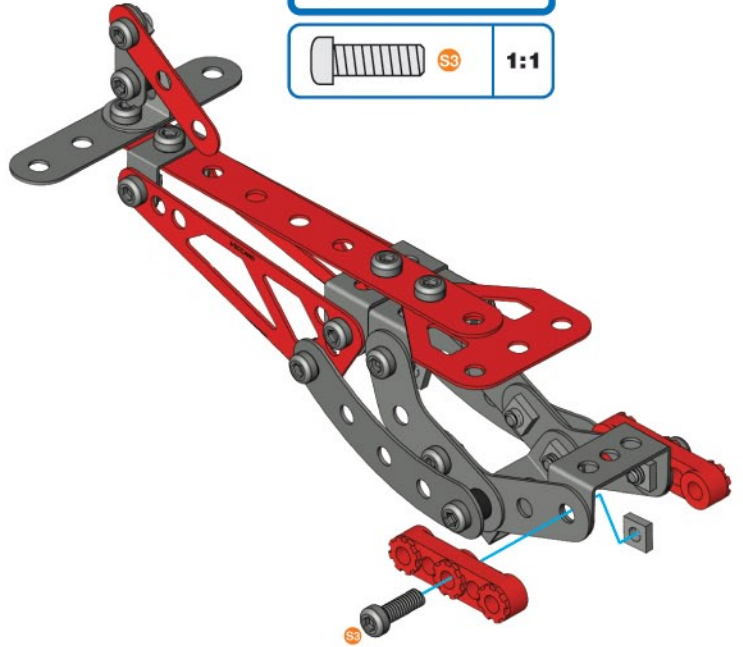
**17**

	x1
	x1
	x1
	x1

	1:1
--	-----

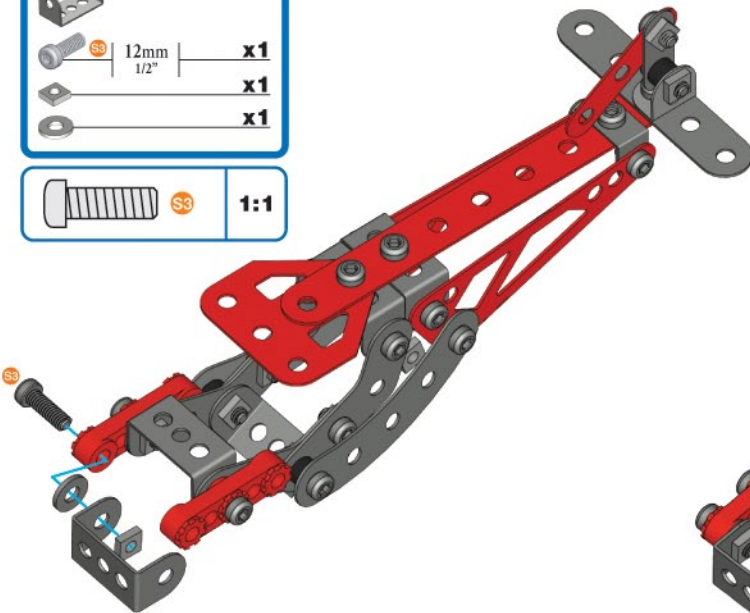
**18**

	x1
	x1
	x1

	1:1
--	-----

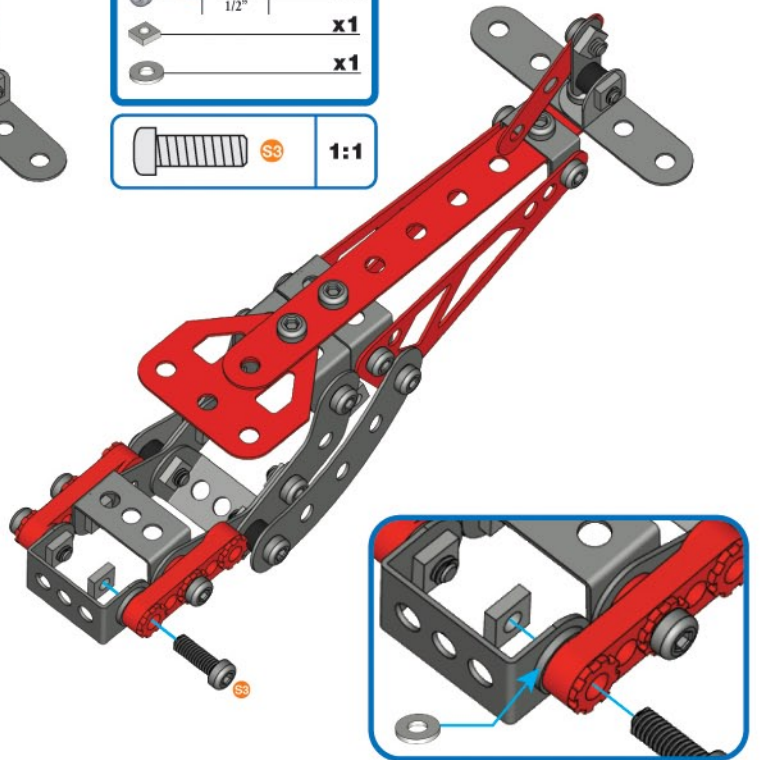

**19**

	<b>x1</b>
	<b>x1</b>
	<b>x1</b>
	<b>x1</b>
	<b>x1</b>
	<b>B2</b> <b>1:1</b>

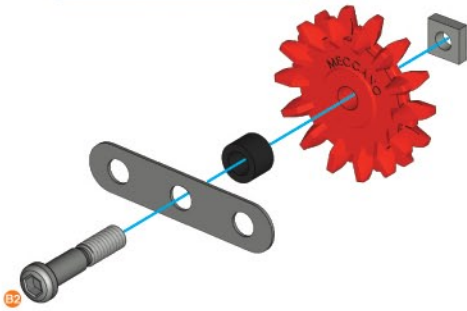
**20****18 + 19 +**

	<b>x1</b>
--	-----------

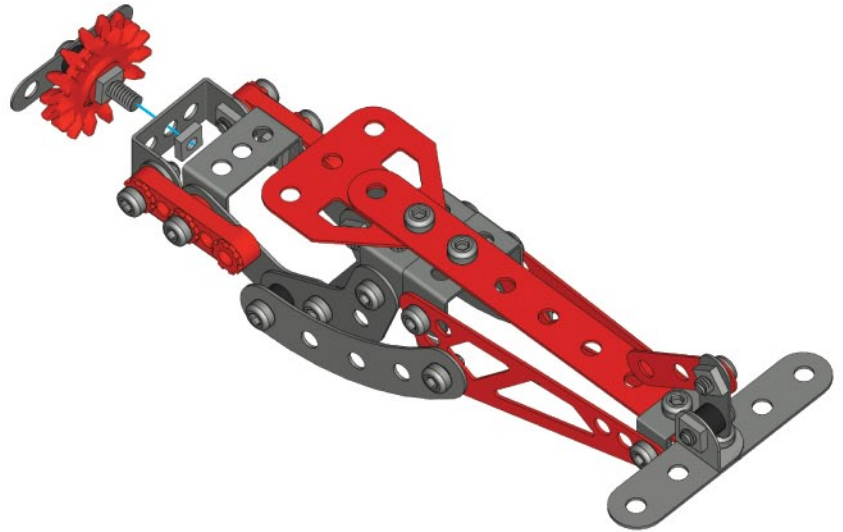
**21**

	<b>x2</b>
	<b>x1</b>
	<b>x1</b>
	<b>S1</b> <b>1:1</b>

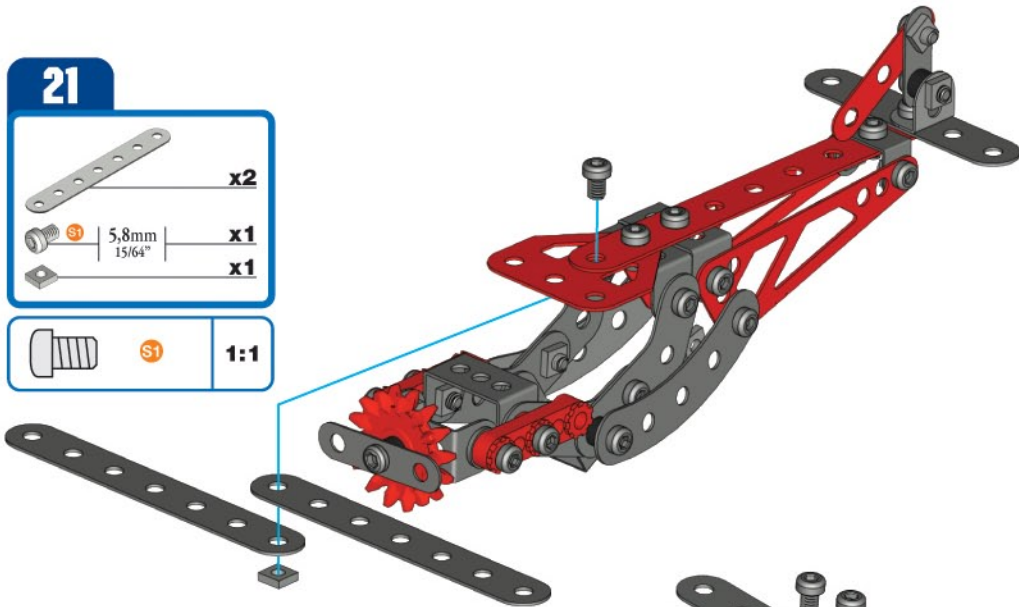
**22**

	<b>x2</b>
	<b>x1</b>
	<b>x2</b>
	<b>x2</b>
	<b>S1</b> <b>1:1</b>

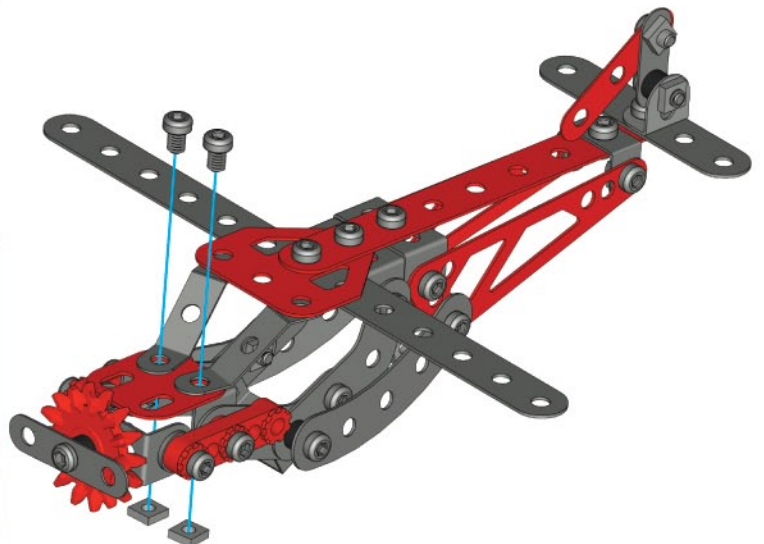

**23**

	x2
	x2
	x2

	1:1
--	-----

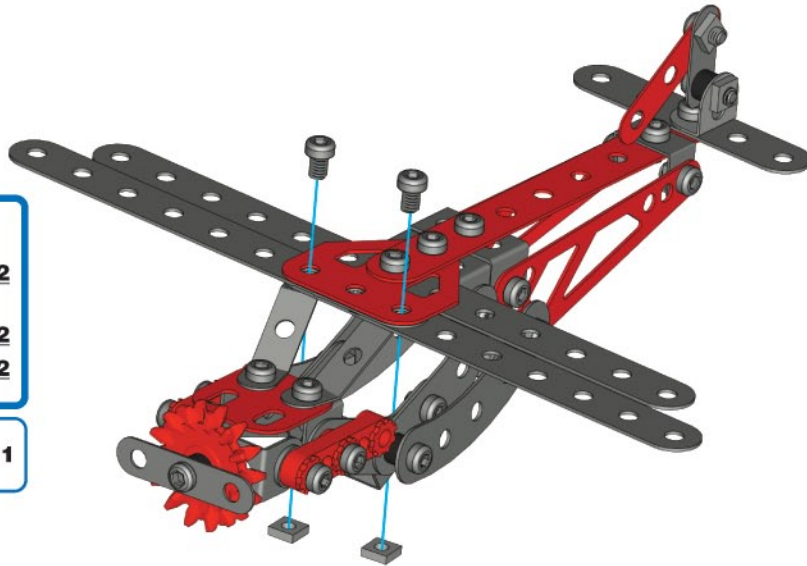

**24**

	x2
	x2
	x2

	1:1
--	-----

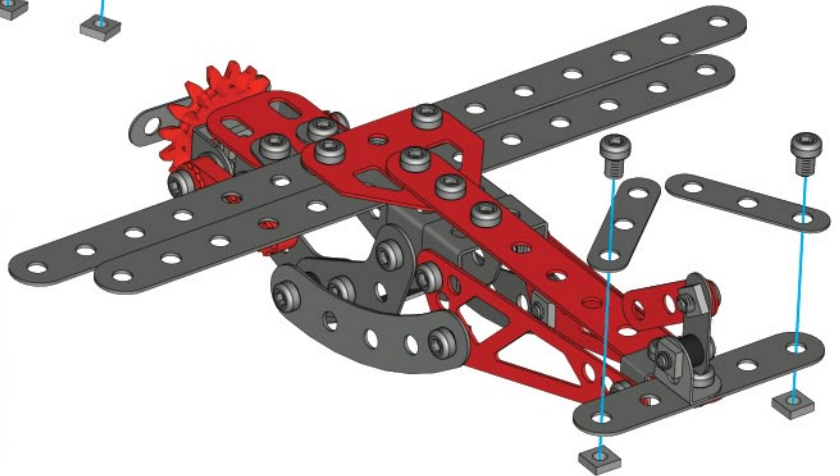

**25**

	x2
	x1
	x1

	1:1
--	-----



**26**

	x2
	x1
	x2
	x2

	1:1
--	-----

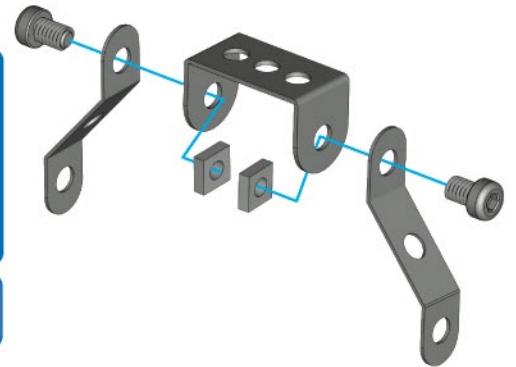

**27** 25 + 26 +

	x1
	x1

	1:1
--	-----

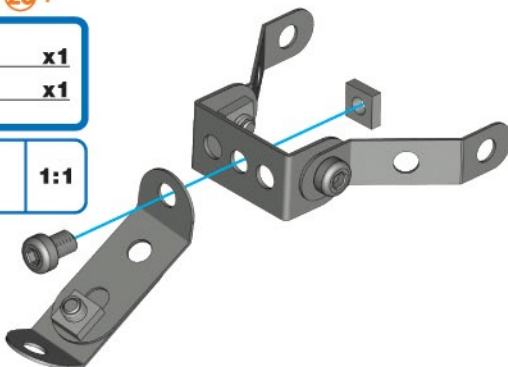

**28**

	x1
	x1
	x1

	1:1
--	-----



**29**    24 + 28 +

	5,8mm 15/64"	x1
		x1

	S1	1:1
--	----	-----

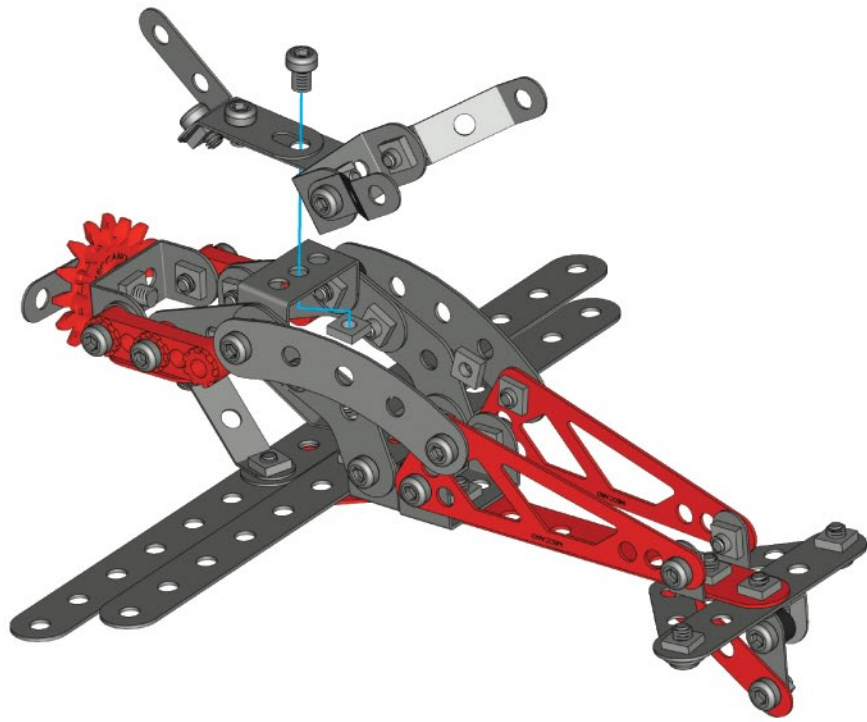

**30**

		x3
		x3
	14,7mm 37/64"	x3
		x3

	B1	1:1
--	----	-----



**31**    29 + 30 +

		x1
--	--	----

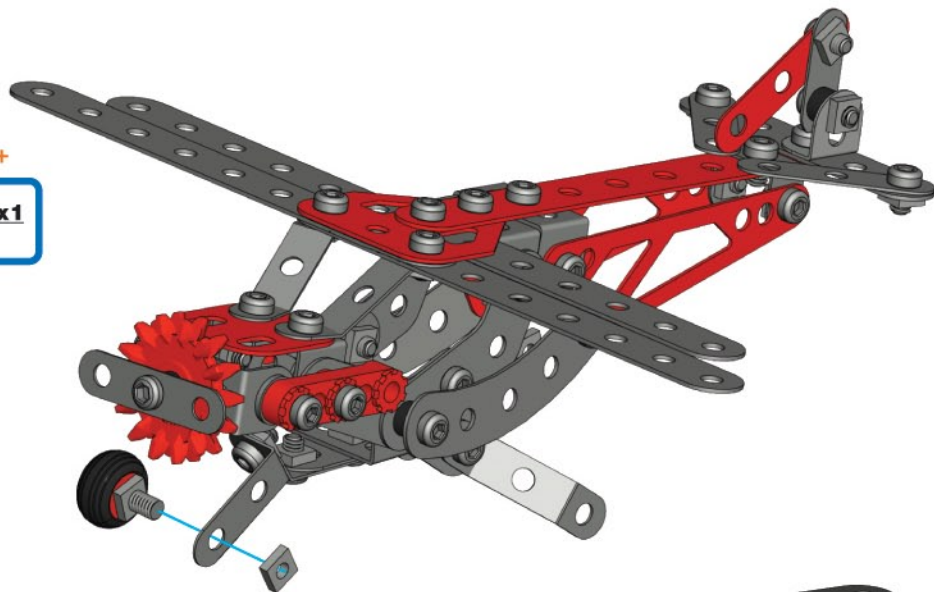

**32**    30 + 31 +

		x2
--	--	----

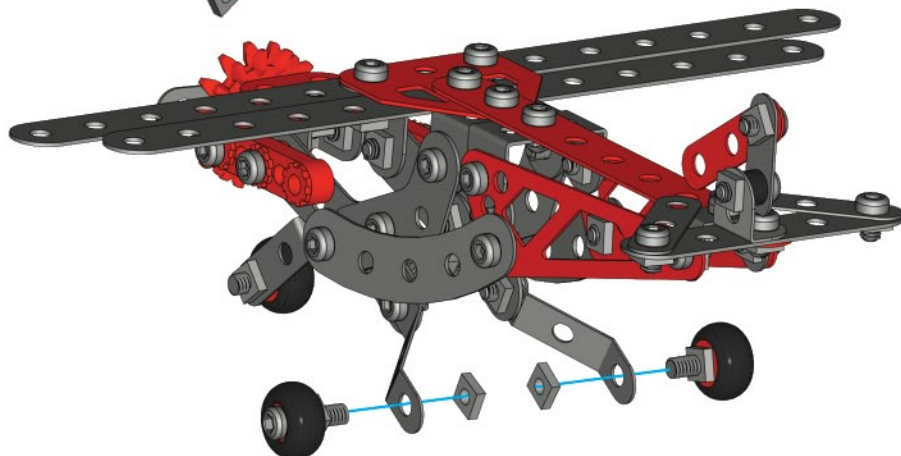





**1**

	x1
	x1
	x1
	x1

	S1	1:1
--	----	-----

Scale 1    Escala 1    Mittakaava 1  
 Echelle 1    Schaal 1    Målestok 1  
 Maßstab 1    Escala 1    Κλίμακα 1  
 Scala 1    Skala 1    масштаб 1

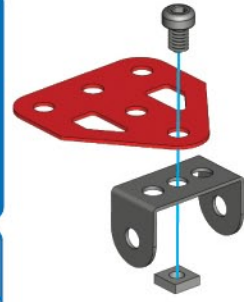

**2**

	x1
	x1
	x1
	x1

	S1	1:1
--	----	-----

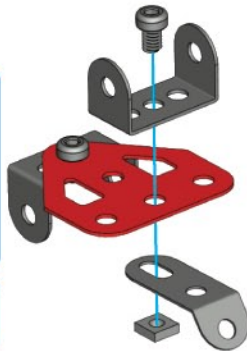

**3**

	x1
	x1
	x1

	S1	1:1
--	----	-----

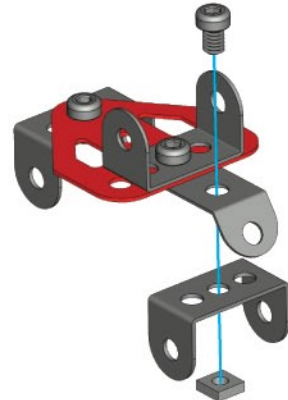

**4**

	x1
	x1
	x1

	S1	1:1
--	----	-----

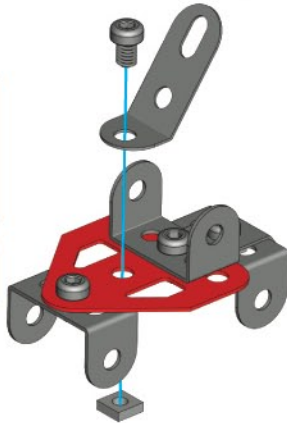

**5**

	x1
	x1
	x1
	x1
	x1

	S3	1:1
--	----	-----

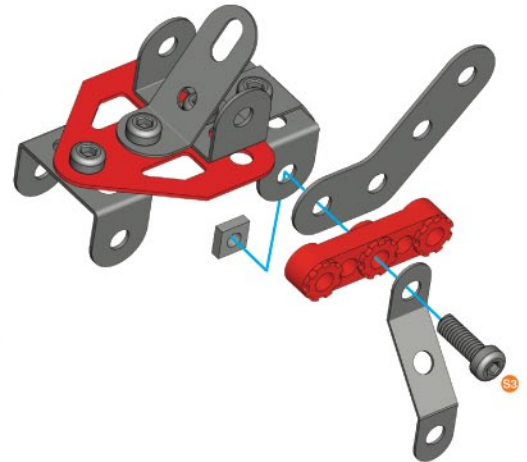

**6**

	x1
	x1
	x1
	x1
	x1

	S3	1:1
--	----	-----

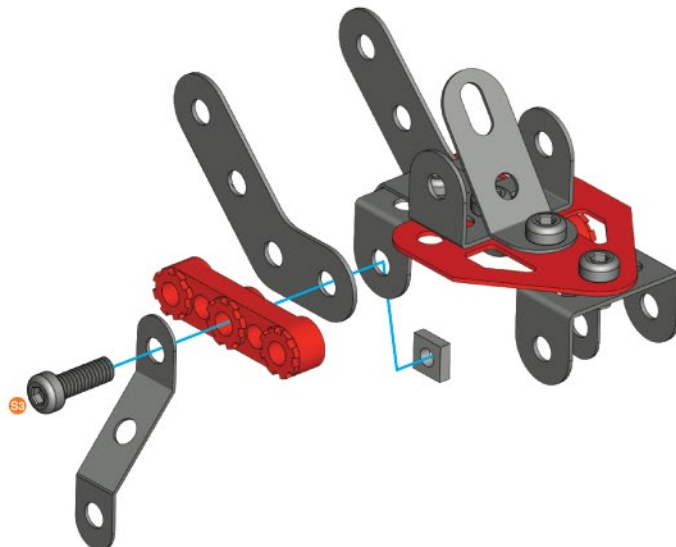

**7**

	x1
	x1
	x1
	x1
	x1

	1:1
--	-----

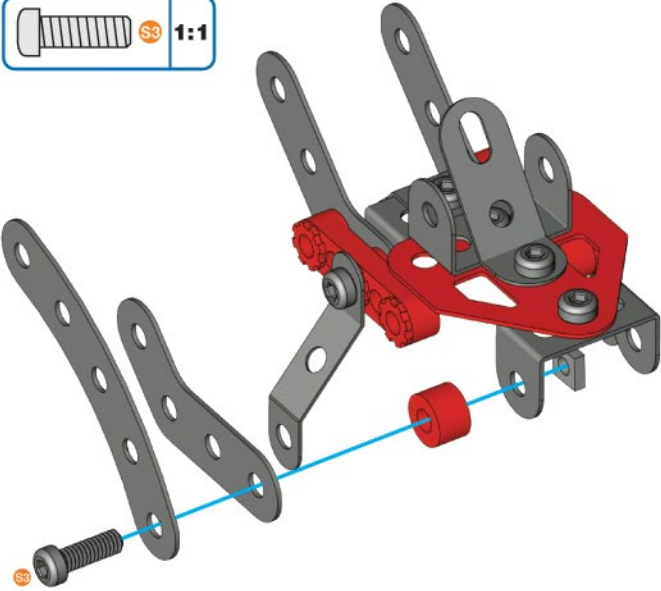

**8**

	x1
	x1
	x1
	x1
	x1

	1:1
--	-----

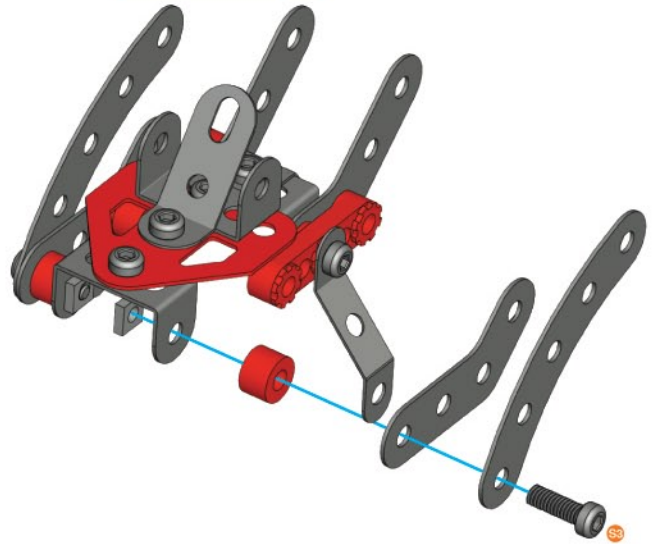

**9**

	x2
	x2

	1:1
--	-----

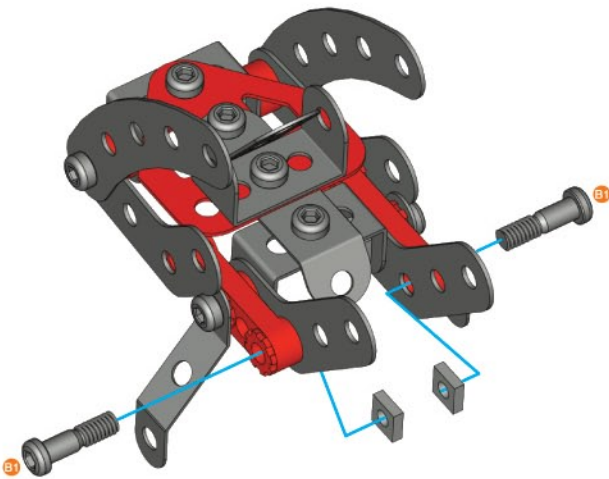

**10**

	x1
	x1
	x2
	x2

	1:1
--	-----

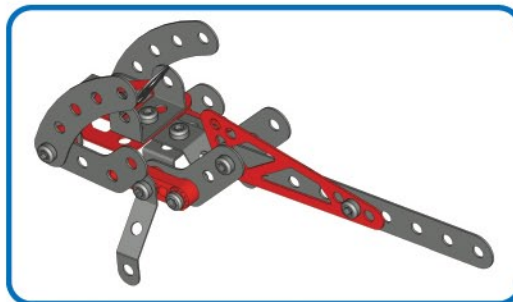
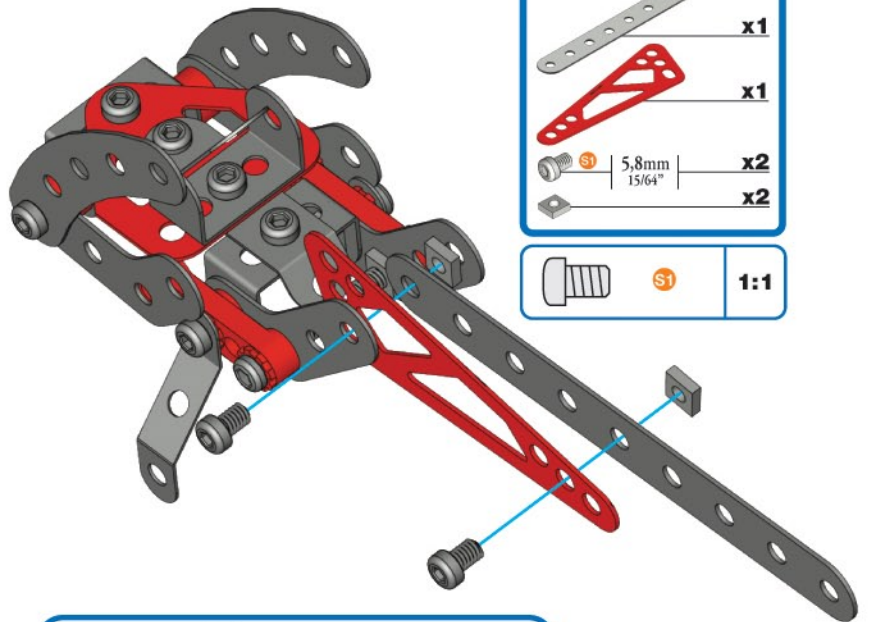

11

- x1
- x1
- 5,8mm | 15/64" x2
- x2

- S1 1:1

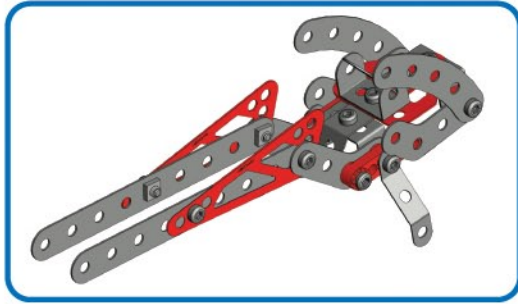
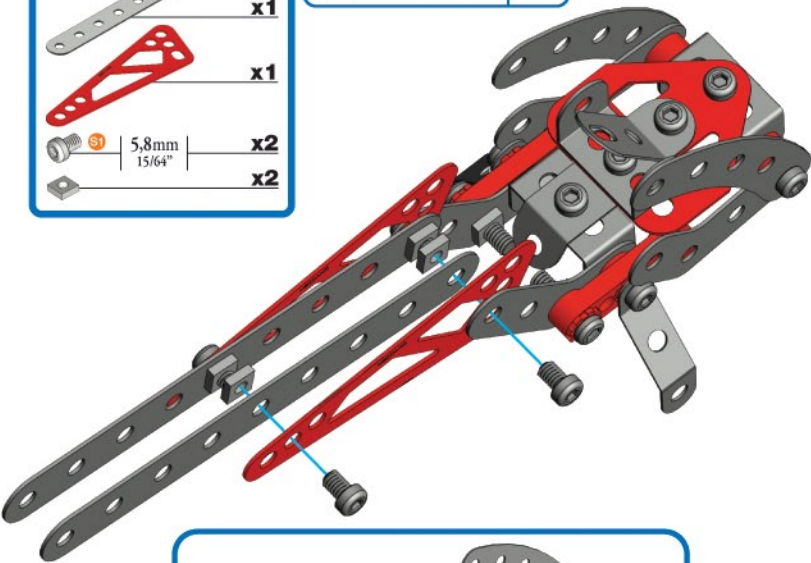

12

- x1
- x2
- 5,8mm | 15/64" x4
- x4

- S1 1:1

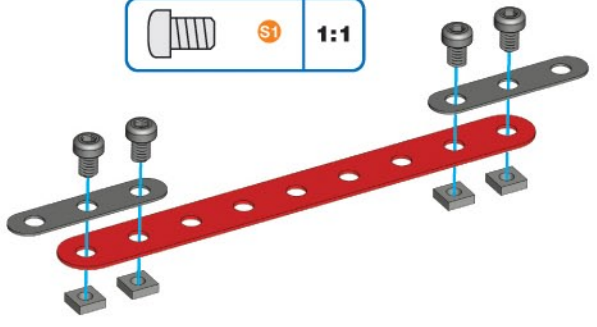

13

- x1
- x1
- 14,7mm | 37/64" x1
- x2

- S1 1:1

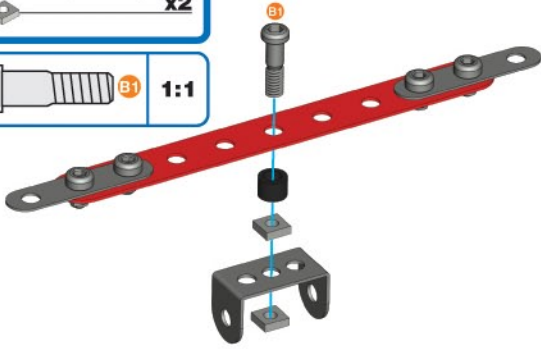

14

- 5,8mm | 15/64" x2
- x2

- S1 1:1

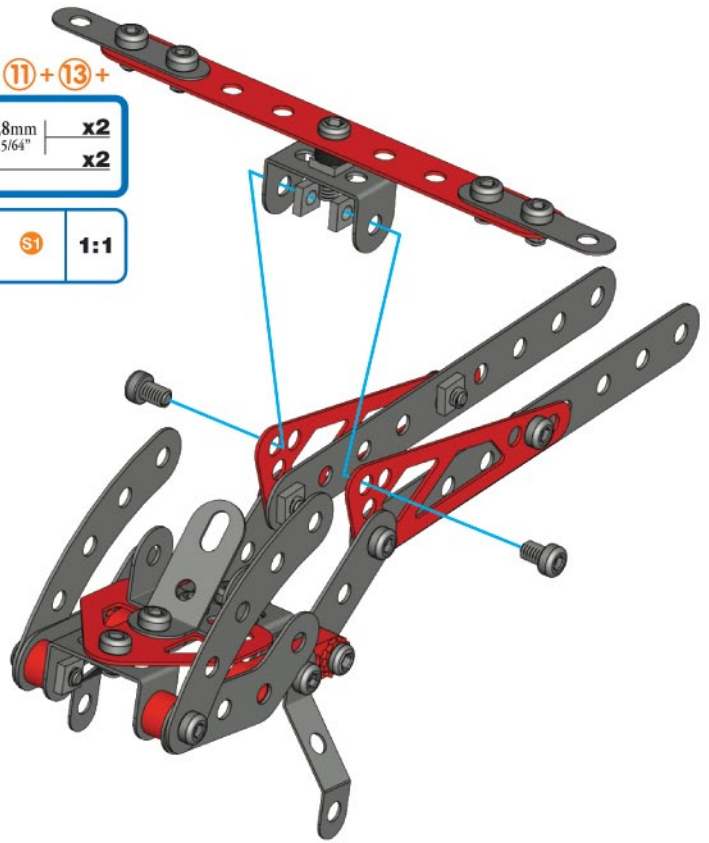

15

- x1
- x1
- 5,8mm | 15/64" x2
- x2

- S1 1:1



**16** (14) + (15) +

	x2
12mm 1/2"	x2
	x2

	S3	1:1
--	----	-----

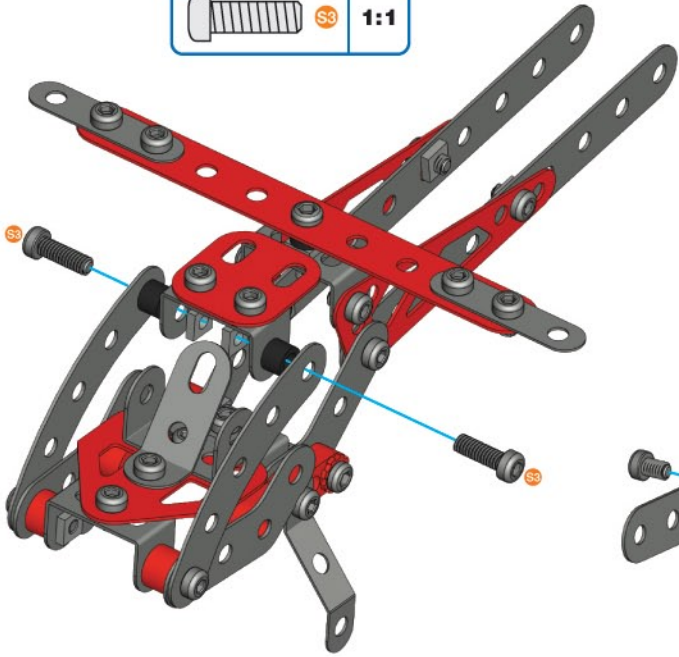

**17**

	x2
5,8mm 15/64"	x2
	x2

	S1	1:1
--	----	-----

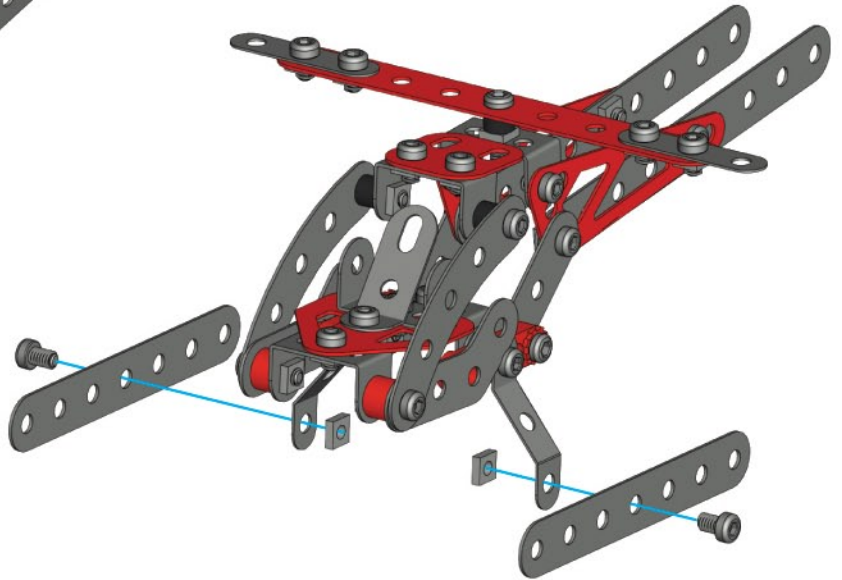

**18**

	x1
5,8mm 15/64"	x1
	x1

	S1	1:1
--	----	-----

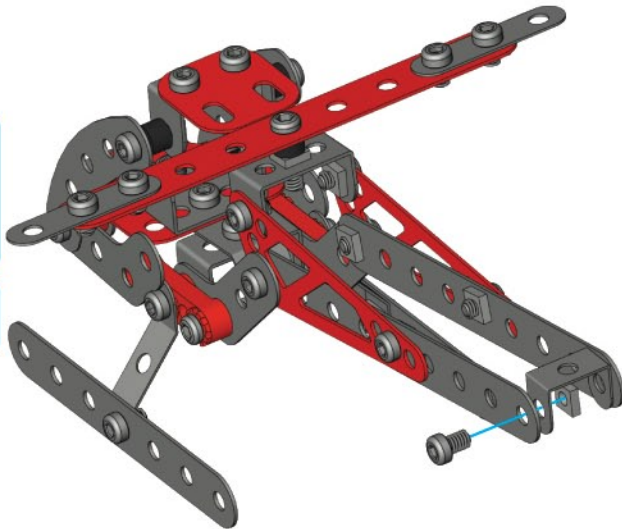

**19**

	x1
	x1
	x1
19mm 3/4"	x1
	x1

	B2	1:1
--	----	-----

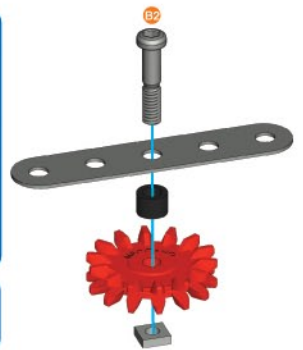

**20** (18) + (19) +

	x1
--	----

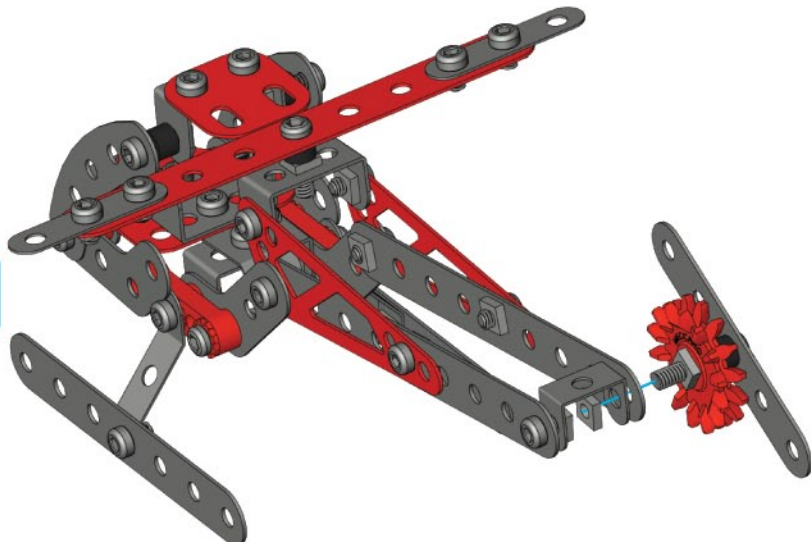



**1**

	<b>x1</b>
	<b>x1</b>
	<b>x1</b>
	<b>x1</b>
	<b>x1</b>

	<b>S1</b>	<b>1:1</b>
--	-----------	------------

Scale 1 | Escala 1 | Mittakaava 1  
 Echelle 1 | Schaal 1 | Määlestok 1  
 Maßstab 1 | Scala 1 | Skala 1 | Кърпакъ 1  
 1:1 | масштаб 1

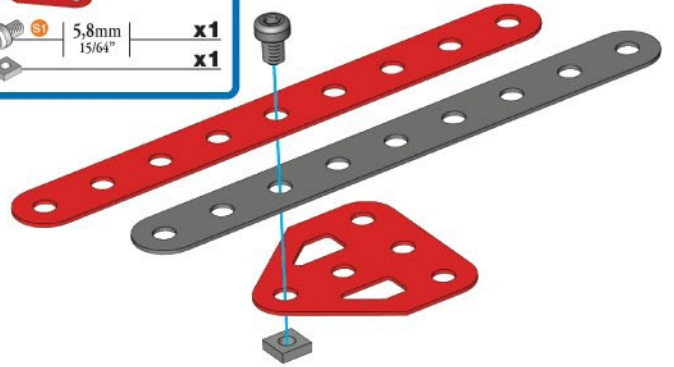

**2** ①+

	<b>x1</b>
	<b>x1</b>
	<b>x1</b>

	<b>S1</b>	<b>1:1</b>
--	-----------	------------

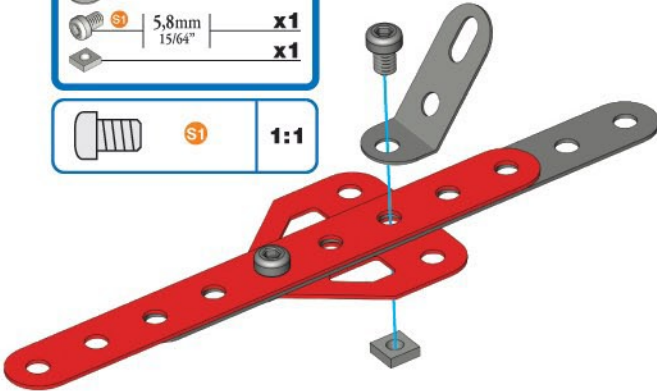

**3**

	<b>x1</b>
	<b>x1</b>
	<b>x1</b>
	<b>x2</b>
	<b>x1</b>
	<b>x1</b>

	<b>S3</b>	<b>1:1</b>
--	-----------	------------

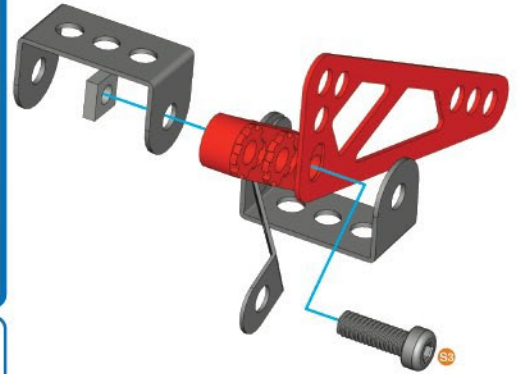

**4**

	<b>x1</b>		<b>x1</b>
	<b>x1</b>		<b>x1</b>
	<b>x1</b>		<b>x1</b>

	<b>S3</b>	<b>1:1</b>
--	-----------	------------

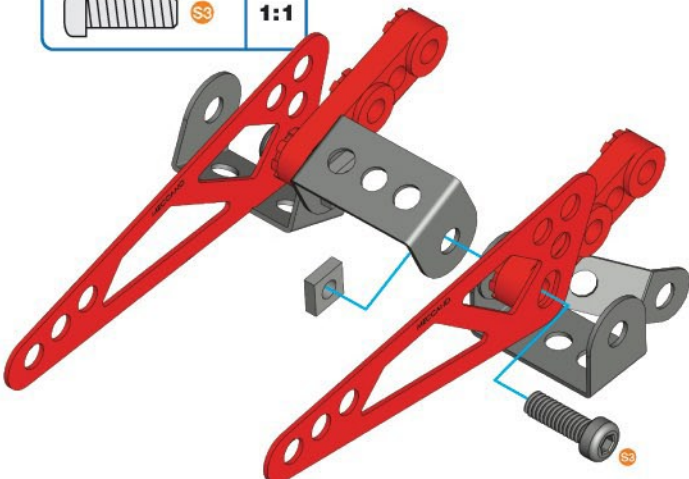



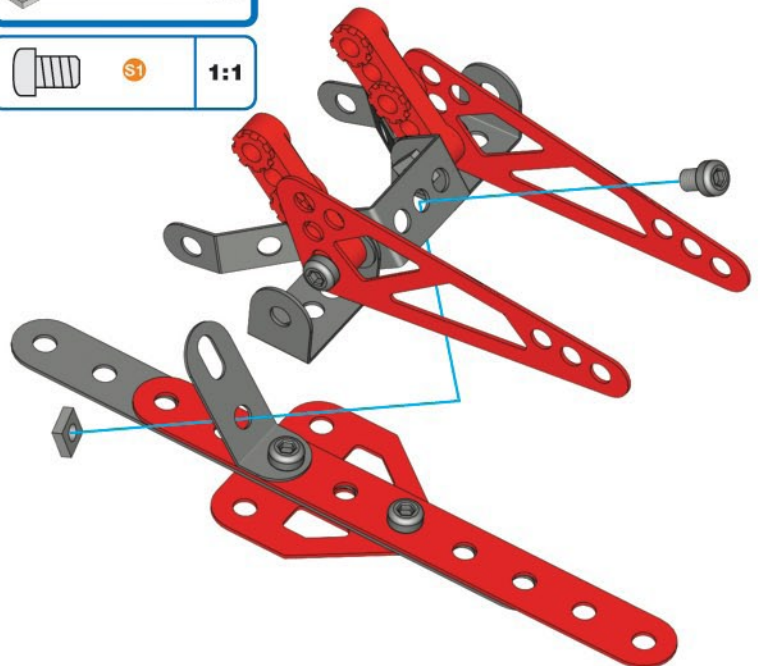

**5** ②+④+

	<b>x1</b>
	<b>x1</b>

	<b>S1</b>	<b>1:1</b>
--	-----------	------------



<b>6</b>			
			<b>x1</b>
			<b>x1</b>
	5,8mm 15/64"		<b>x1</b>
			<b>x1</b>

	<b>S1</b>		<b>1:1</b>
---	-----------	--	------------

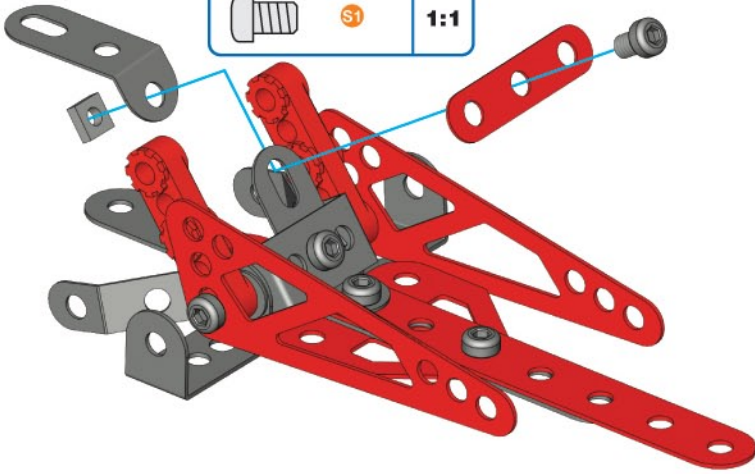



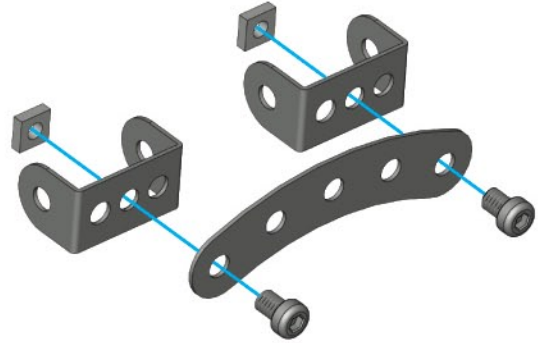

<b>7</b>			
			<b>x1</b>
			<b>x2</b>
	5,8mm 15/64"		<b>x2</b>
			<b>x2</b>

	<b>S1</b>		<b>1:1</b>
---	-----------	--	------------

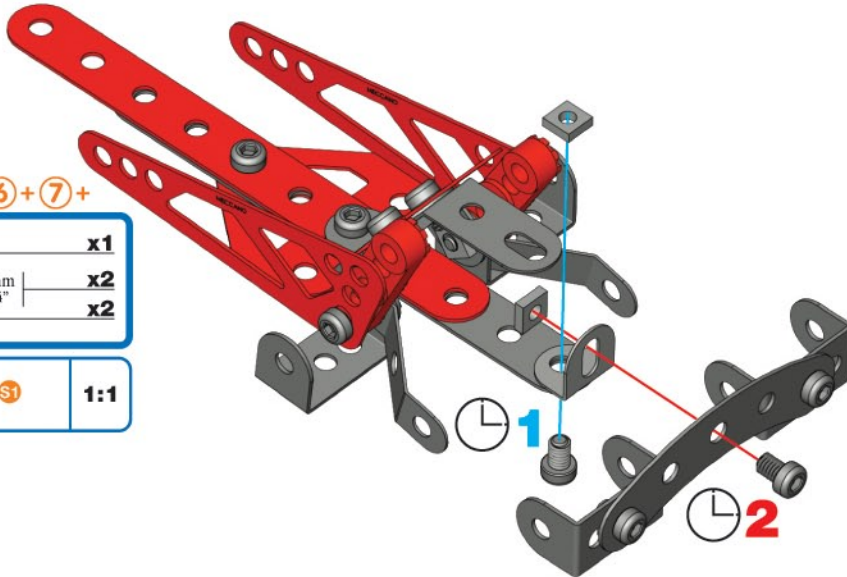





<b>8</b>	<b>(6)+(7)+</b>		
			<b>x1</b>
	5,8mm 15/64"		<b>x2</b>
			<b>x2</b>
	<b>S1</b>		<b>1:1</b>



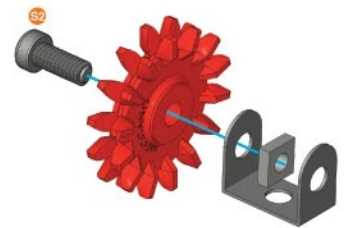



<b>9</b>			
			<b>x1</b>
			<b>x1</b>
	9,5mm 3/8"		<b>x1</b>
			<b>x1</b>

	<b>S2</b>		<b>1:1</b>
---	-----------	--	------------

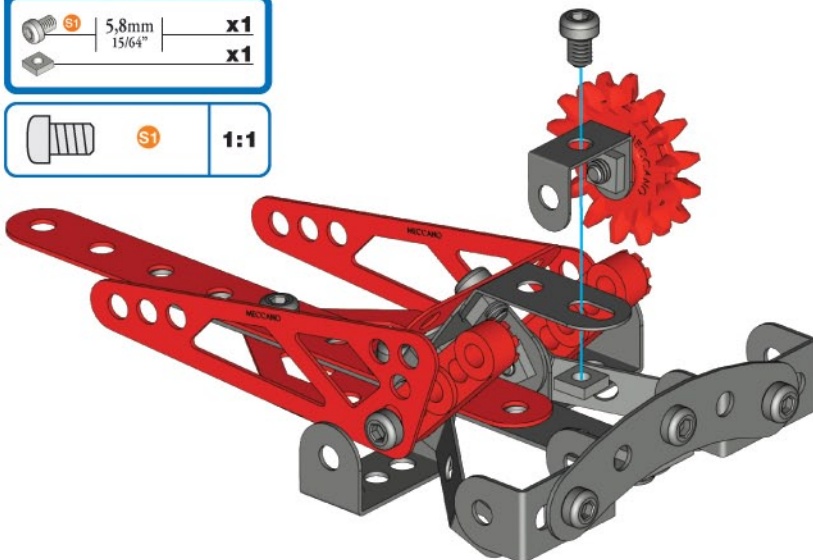

<b>10</b>	<b>(8)+(9)+</b>		
	5,8mm 15/64"		<b>x1</b>
			<b>x1</b>
	<b>S1</b>		<b>1:1</b>



<b>11</b>			
			<b>x1</b>
			<b>x1</b>
	5,8mm 15/64"		<b>x1</b>
			<b>x1</b>

	<b>S1</b>		<b>1:1</b>
---	-----------	--	------------

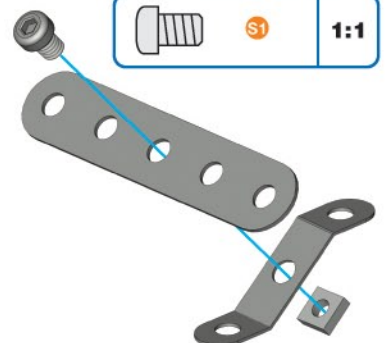

**12** (10) + (11) +

	x1
	x1
	x1

	(S1)	1:1
--	------	-----

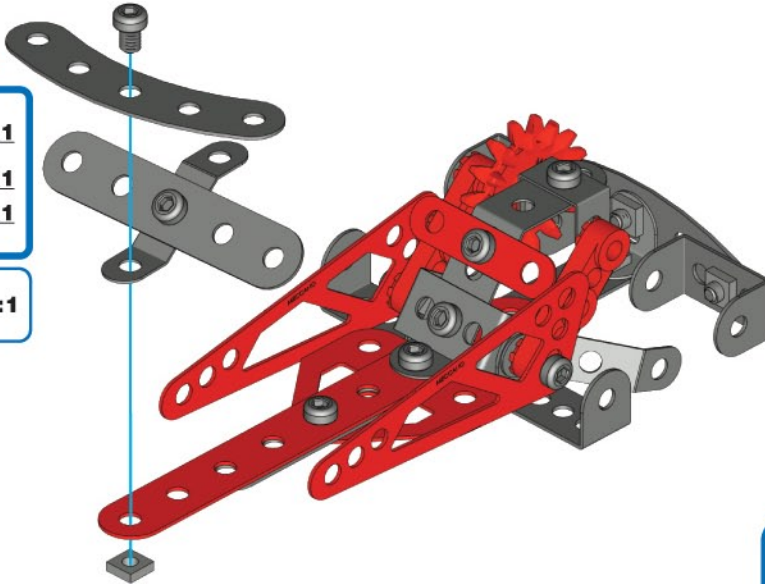

**13**

	x4
	x4
	x4
	x4

	(B1)	1:1
--	------	-----

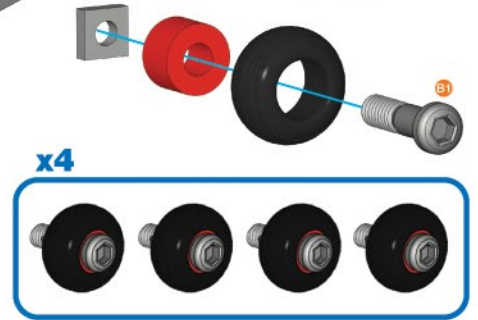

**14** (12) + (13) +

	x2
--	----

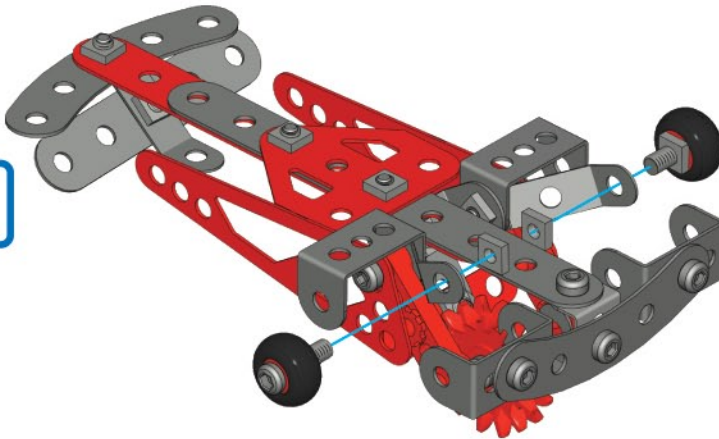

**15** (13) + (14) +

	x2
	x2
	x4

	(S1)	1:1
--	------	-----

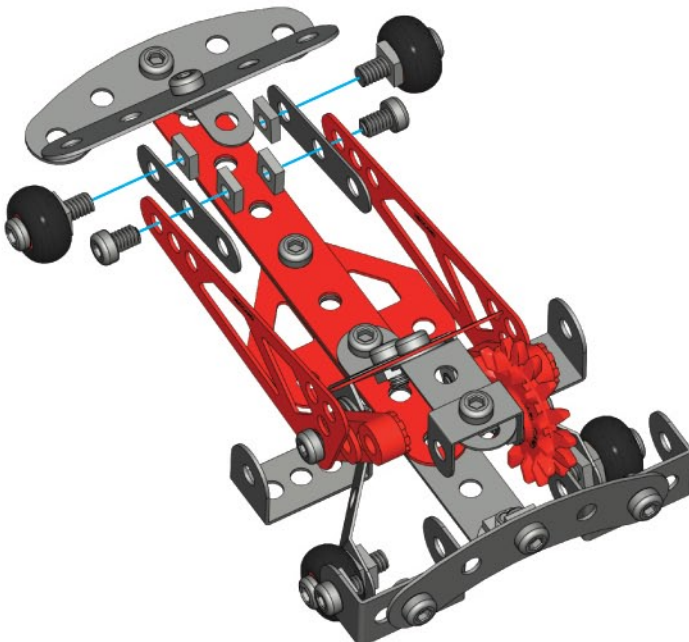

**16**

	x2
	x4
	x4

	(S1)	1:1
--	------	-----

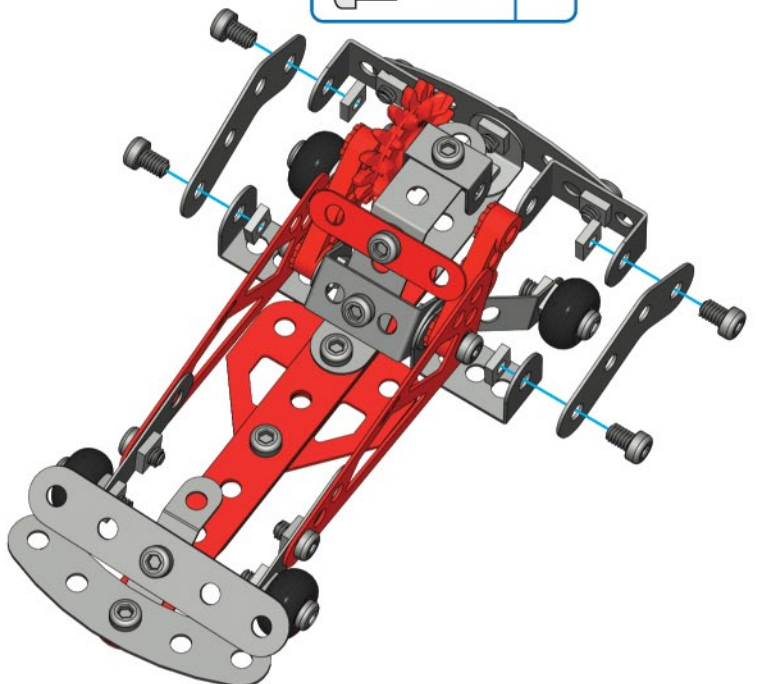

**17**

	<b>x1</b>
	<b>x1</b>
	<b>x2</b>
	<b>x2</b>

	<b>S1</b>	<b>1:1</b>
--	-----------	------------

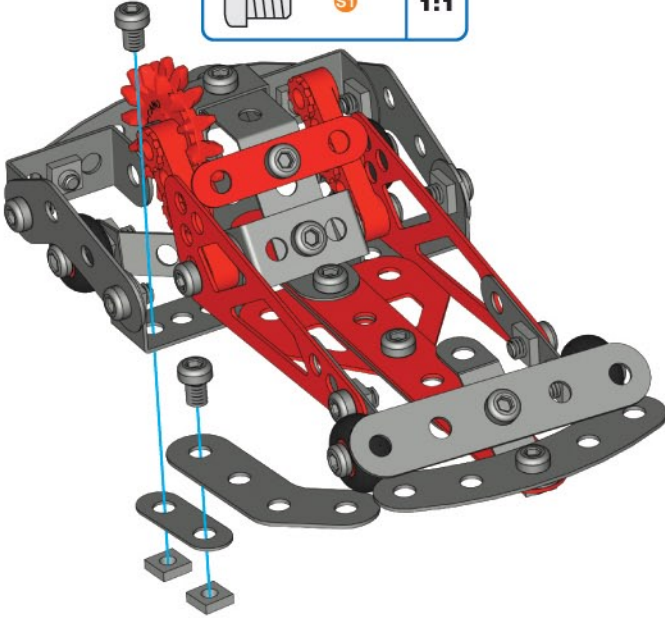
**18**

	<b>x1</b>
	<b>x1</b>
	<b>x2</b>
	<b>x2</b>

	<b>S1</b>	<b>1:1</b>
--	-----------	------------

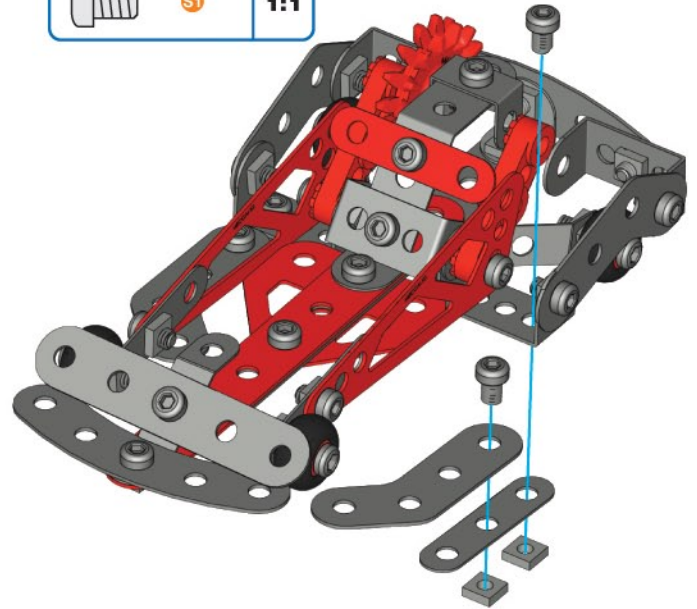
**19**

	<b>x1</b>
	<b>x1</b>
	<b>x2</b>
	<b>x2</b>

	<b>S1</b>	<b>1:1</b>
--	-----------	------------

**20**

	<b>x1</b>
	<b>x1</b>
	<b>x1</b>
	<b>x1</b>

	<b>S3</b>	<b>1:1</b>
--	-----------	------------

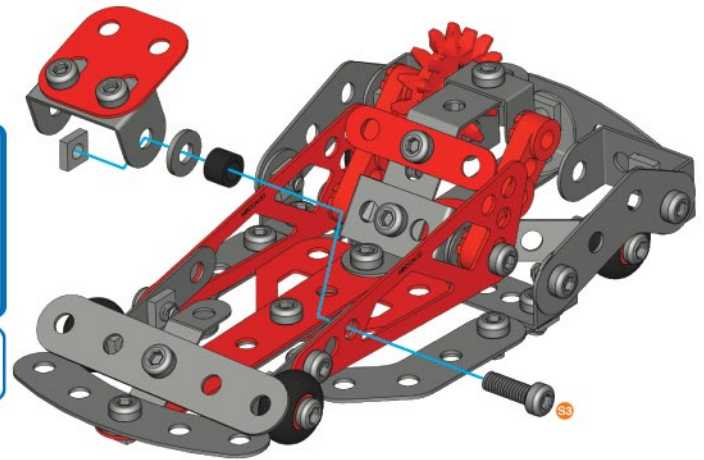
**21**

	<b>x1</b>
	<b>x1</b>
	<b>x1</b>
	<b>x1</b>

	<b>S3</b>	<b>1:1</b>
--	-----------	------------

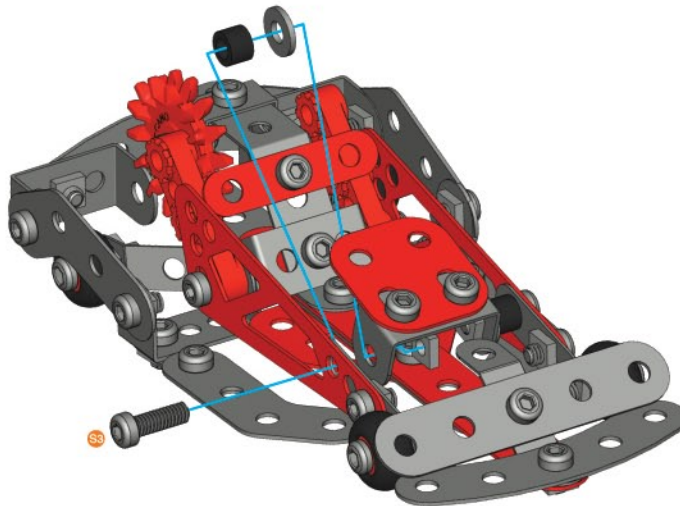



**GB** Remove all packaging before use. Retain this information, addresses and phone numbers for future reference. Content may vary from pictures. Meccano reserves the right to discontinue the website [www.meccano.com](http://www.meccano.com) at any time. An adult should periodically check this toy to ensure no damage or hazard exist if so, remove from use. Children should be supervised during play.

**F** Retirer tout l'emballage avant utilisation. Conserver les informations, adresses et numéros de téléphone pour consultation ultérieure. Le contenu peut différer des images. Meccano se réserve le droit de supprimer le site Internet [www.meccano.fr](http://www.meccano.fr) à tout moment. Un adulte doit régulièrement examiner ce jouet afin de s'assurer qu'il ne présente pas de dommage ni de risque. En cas de problème, ne plus l'utiliser. Les enfants doivent être surveillés lorsqu'ils jouent.

**E** Retire todo el embalaje antes de utilizar el producto. Conserve toda la información, las direcciones y los números de teléfono para futuras referencias. El contenido del paquete puede no corresponder con las imágenes. Meccano se reserva el derecho a suspender el sitio web [www.meccano.com](http://www.meccano.com) en cualquier momento. Un adulto debe revisar de forma periódica el juguete para asegurarse de que no supone un riesgo o peligro para el niño; si así fuera el caso, interrumpa su uso. Supervise a los niños mientras juegan con el producto.

**D** Entfernen Sie vor der Benutzung sämtliche Verpackungsmaterialien. Alle Informationen, Adressen und Telefonnummern bitte für mögliche Rückfragen aufbewahren. Der Packungsinhalt kann von den Bildern abweichen. Meccano behält sich das Recht vor, den Betrieb der Website [www.meccano.com](http://www.meccano.com) jederzeit einzustellen. Ein Erwachsener sollte regelmäßig sicherstellen, dass das Spielzeug keine Gefahr darstellt, und es gegebenenfalls entfernen. Kinder sollten beim Spielen beaufsichtigt werden.

**NL** Verwijder de verpakking voor gebruik. Bewaar deze informatie, adressen en telefoonnummers voor toekomstig gebruik. Inhoud kan afwijken van illustraties. Meccano behoudt zich het recht voor de website [www.meccano.com](http://www.meccano.com) wanneer gewenst buiten gebruik te stellen. Een volwassene dient dit speelgoed regelmatig te controleren op schade en gevaren. Indien het speelgoed is beschadigd of indien er een gevaarlijke situatie kan ontstaan, dient het product te worden weggegooid. Ouderlijk toezicht is vereist als kinderen met dit speelgoed spelen.

**I** Rimuovere l'imballaggio prima dell'uso. Conservare informazioni, indirizzi e numeri di telefono per riferimento futuro. Il prodotto potrebbe differire dalle immagini. Meccano si riserva il diritto di rimuovere il sito [www.meccano.com](http://www.meccano.com) in qualsiasi momento. È consigliabile un controllo periodico del giocattolo da parte di un adulto: in caso di danni o rischi interrompere l'uso. È richiesta la supervisione di un adulto durante il gioco.

**P** Remova totalmente a embalagem antes de utilizar. Guarde estas informações, as moradas e os números de telefone para consulta futura. O conteúdo poderá ser diferente das ilustrações. A Meccano reserva-se o direito de descontinuar o sítio [www.meccano.com](http://www.meccano.com) a qualquer altura. Um adulto deve verificar o brinquedo periodicamente para garantir que não ele não apresenta danos ou riscos. Se houver, é necessário que o brinquedo seja retirado de uso. Crianças devem ser supervisionadas enquanto brincam.

**GR** Πριν την χρήση αφαιρέστε όλα τα υλικά της συσκευασίας. Διατηρήστε αυτές τις πληροφορίες, τις διευθύνσεις και τους αριθμούς τηλεφώνου για μελλοντική αναφορά. Το περιεχόμενο ενδέχεται να διαφέρει από τις εικόνες. Η Meccano διατηρεί το δικαίωμα να διακόψει τη λειτουργία της τοποθεσίας [www.meccano.com](http://www.meccano.com) ανά πάσα στιγμή. Ένας ενήλικας θα πρέπει να εξετάζει τακτικά αυτό το παιχνίδι και να διακόπτει τη χρήση του σε περίπτωση εντοπισμού βλαβών ή κινδύνων. Τα παιδιά θα πρέπει να παίζουν υπό επίτηρησή.

**S** Ta bort alla förpackningar före användning. Spara den här informationen, adresser och telefonnummer för framtida referens. Innehållet kan skilja sig från bilderna. Meccano förbehåller sig rätten att när som helst ta bort webbplatsen [www.meccano.com](http://www.meccano.com). En vuxen ska regelbundet undersöka den här leksaken för att säkerställa att det inte finns några skador eller faror rörande den. Om det finns några ska den inte användas längre. Håll borta från hinder och elektriska risker.

**DK** Fjern al emballage før brug. Gem disse oplysninger, adresser og telefonnumre for fremtidig brug. Indholdet kan være forskelligt fra billederne. Meccano forbeholder sig ret til at nedlægge hjemmesiden [www.meccano.com](http://www.meccano.com) til enhver tid. En voksen bør med jævne mellemrum undersøge leken for at se om den er skadet, eller om det foreligger noen fare. Hvis det er tilfældet, må leken ikke lenger brukes. Barn bør holdes under oppsyn når de leker.

**FIN** Poista kaikki pakkausmateriaali ennen käyttöä. Säilytä nämä tiedot, osoitteet ja puhelinnumerot tulevia tarpeita varten. Sisältö saattaa poiketa kuvista. Meccano pidättää oikeuden lakkauttaa sivuston [www.meccano.com](http://www.meccano.com) milloin tahansa. Aikuisen tulee säännöllisesti tarkistaa, että lelu ei ole vaurioitunut ja muuttunut vaaralliseksi. Jos näin on käynyt, lelu tulee poistaa käytöstä. Lasten tulee leikkiä vain aikuisen valvonnassa.

**RU** Снимите все упаковочные материалы перед использованием. Запишите указанные на упаковке адреса и номера телефонов, чтобы у вас была возможность связаться с нами. Содержимое упаковки может отличаться от иллюстрации. Компания Meccano оставляет за собой право прекратить использование сайта [www.meccano.com](http://www.meccano.com) в любое время. Регулярно проверяйте состояние игрушки на наличие повреждений и возможных рисков для ребенка. Если таковые имеются, игрушку не следует использовать. Во время игры за детьми следует присматривать.

**GB** ⚠ CAUTION: Stickers not intended to be placed on skin.

**F** ⚠ MISE EN GARDE: Les autocollants ne sont pas destinés à être placés sur la peau.

**E** ⚠ PRECAUCIÓN: Las calcomanías no deben colocarse sobre la piel.

**D** ⚠ ACHTUNG: Sticker sind nicht zum Aufkleben auf die Haut geeignet.

**NL** ⚠ VOORZICHTIG: Stickers zijn niet voor op de huid bedoeld.

**I** ⚠ ATTENZIONE: Non applicare gli adesivi sulla pelle.

**P** ⚠ ATENÇÃO: os autocolantes não devem ser colocados na pele.

**GR** ⚠ ΠΡΟΣΟΧΗ: Μην κολλάτε τα αυτοκόλλητα στο δέρμα σας.

**S** ⚠ VARNING: Klistermärkena bör inte sättas på huden.

**DK** ⚠ ADVARSEL: Klistermærker er ikke beregnet til at sætte på huden.

**FIN** ⚠ VAROITUS: Tarroja ei saa kiinnittää ihoon.

**RU** ⚠ ОСТОРОЖНО: Стикеры не предназначены для приклеивания к коже.

**GB** ⚠ Warning! CHOKING HAZARD - Small parts.

**F** ⚠ Attention ! RISQUE D'ÉTOUFFEMENT - Contient de petits éléments.

**E** ⚠ Advertencia: PELIGRO DE ASFIXIA - Contiene piezas pequeñas. No conveniente para niños menores de 3 años.

**D** ⚠ Achtung: ERSTICKUNGSGEFAHR - Kleinteile.

**NL** ⚠ Waarschuwing: VERSTIKKINGSGEVAAR - Kleine onderdelen.

**I** ⚠ Attenzione: RISCHIO DI SOFFOCAMENTO - Pezzi piccoli.

**P** ⚠ Aviso: PERIGO DE ASFIXIA - Peças pequenas.

**GR** ⚠ Προειδοποίηση: ΚΙΝΔΥΝΟΣ ΠΝΙΓΜΟΥ — Μικρά μέρη.

**S** ⚠ Varning: RISK FÖR KVÄVNING - Små delar.

**DK** ⚠ Advarsel: KVAELNINGSFARE - Små dele.

**FIN** ⚠ Varoitus: TUKEHTUMISVAARA - Pieniä osia.

**RU** ⚠ Осторожно! ОПАСНОСТЬ УДУШЬЯ - мелкие детали.



© 04/2014 MECCANO for packaging, instructions and models built with this set. © 04/2014 MECCANO pour l'emballage, les notices et modèles de ce coffret. © MECCANO is an exclusive trademark of MECCANO. Spin Master Logo is a trademark of Spin Master Ltd. © MECCANO est une marque de commerce exclusive de MECCANO. Le logo de Spin Master est une marque de commerce de Spin Master Ltd. All rights reserved. Tous droits réservés.



UK - 0800 204 1191. [SERVICEUK@SPINMASTER.COM](mailto:SERVICEUK@SPINMASTER.COM)  
FRANCE - 0800 909 150. [SERVICEFR@SPINMASTER.COM](mailto:SERVICEFR@SPINMASTER.COM)  
ESPAÑA - [SERVIDIO@SPINMASTER.COM](mailto:SERVIDIO@SPINMASTER.COM)  
DEUTSCHLAND - 0800 0101 0222. [KUNDENSERVICE@SPINMASTER.COM](mailto:KUNDENSERVICE@SPINMASTER.COM)  
SCHWEIZ - 0800 561 350 • ÖSTERREICH - 0800 29 72 67  
NEDERLAND - 0800 022 36 83. [KLANTENSERVICE@SPINMASTER.COM](mailto:KLANTENSERVICE@SPINMASTER.COM)  
BELGIË/BELGIQUE - 0800 77 698 • LUXEMBOURG - 800 28 044  
ITALIA - 800 788 532. [SERVIZIO@SPINMASTER.COM](mailto:SERVIZIO@SPINMASTER.COM)  
MEXICO - 53.51.44.00  
[WWW.SPINMASTER.COM](http://WWW.SPINMASTER.COM)

NORTH AMERICA: AMÉRIQUE DU NORD: 1-800-622-8339 [customer-care@spinmaster.com](mailto:customer-care@spinmaster.com)

SPIN MASTER LTD., 450 FRONT STREET WEST, TORONTO, ON M5V 1B6 CANADA. Imported into EU by SPIN MASTER INTERNATIONAL, S.A.R.L., 16 AVENUE PASTEUR, L-2310, LUXEMBOURG. [www.spinmaster.com](http://www.spinmaster.com)  
Made in China for / Fabriqué en Chine pour Meccano : 363, avenue de Saint-Exupéry 62100 Calais - France



T91674\_0001\_20066591\_GML\_IB\_R1\_W1

833555 104 111W1