

MECCANOIDS™

BOOK OF MODELS

Voorbeeldenboek
Livre des modèles
Libro dei modelli
Modellbuch
Modellbok
Libro de modelos

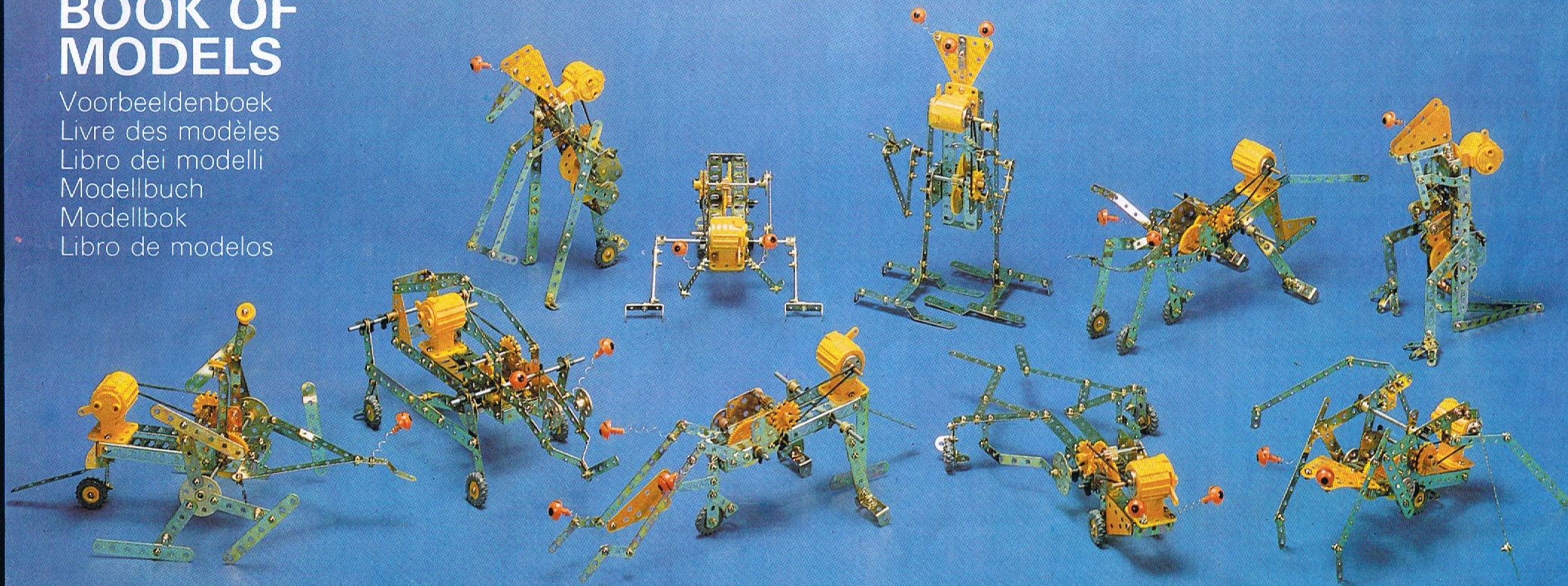

How to use Meccano Please read this carefully before you start to build

This book contains all the instructions you need to build with Meccano. Each model is assembled in sections and, at the start of each section, there is a photograph of the particular components used in that section. These photographs will help you identify the parts needed. You should first select the components from your set to avoid having to search for them during assembly. The sequence of assembly, i.e. progressing from one section to the next in correct order, should be followed as set out in the illustrations.

In most cases, the parts used in the models can be identified simply by looking at the illustrations, but where the identity of a part may not be clear, its part number is marked on the illustrations.

You will be able to identify these, and all the parts in the models, by studying the individual pictures of parts printed in this booklet.

Even if you have never used Meccano before you'll find that, with just a little practice, you can design and build almost anything. It's easy—and it's fun. And the only tools you need are a screwdriver and two spanners which are included in every kit. In case you haven't used tools before, this is how they work:

The screwdriver is used to turn bolts by putting the blade in the bolt's slot and turning it to the right. To undo the bolt you turn the screwdriver the other way.

Nuts go on the ends of bolts. Use your fingers to get the nut on to the end of the bolt and then the screwdriver to tighten the bolt. To make the joint really firm, hold the nut with the spanner while you tighten the bolt.

When you want a piece to move freely between a nut and bolt you can make a locknut... Just thread two nuts on to a bolt and tighten them against each other.

When you're building Meccano models you will sometimes need certain standard joints called Basic Constructions. Numbered BC1, BC2, etc., they'll help you to build all your models more easily. The ones shown on page 5 are those needed for the models in this book.



BC1 This joins two strips together so that they can move. It's one kind of locknut. You push a bolt through the strips, thread one nut on to the bolt (but don't tighten it so much that the strips can't move) thread on the second nut and tighten it against the first. You'll have to hold the first nut with the second spanner.



BC2 This is another kind of locknut. Push the bolt through one of the strips and thread on the first nut. Then push the second strip over the end of the bolt and thread on the second nut. Tighten the nuts against the second strip so that the first strip moves around the nuts and the bolt.

BC4 This is a way of joining two strips together with two nuts and bolts.

BC15 This is a collar used to form a bearing or a support for an axle. The bolt must not obstruct the centre hole carrying the axle and the nut should be locked against the supporting plate or strip.

Nuts and bolts can be used in different ways for different jobs. These 'bolt fixtures' have been numbered BF1, BF2, etc., so that you can recognise them in the photographs.

You will also see these symbols  and .

The first, , indicates that the parts concerned will move freely. The second, , shows that these parts will also move but that there will be some resistance to totally free movement, allowing the parts to stay in any position you want.

Mode d'emploi du Meccano Veuillez lire ceci attentivement avant de commencer vos constructions

Cette notice contient toutes les indications nécessaires pour faire des constructions avec Meccano. Chaque modèle est assemblé en sections et, au début de chaque section, se trouve une photographie des pièces qui y sont utilisées. Ces photographies vous permettront d'identifier les pièces nécessaires. Vous devriez d'abord les sélectionner pour ne pas avoir à les chercher pendant l'assemblage. La séquence de l'assemblage, c.à.d. le passage d'une section à une autre dans le bon ordre, devrait être suivie d'après les illustrations.

Dans la plupart des cas, les pièces devant être utilisées pour les modèles peuvent être identifiées simplement en se référant aux illustrations mais lorsque l'identification d'une pièce n'est pas claire, son numéro est donné sur l'illustration.

Vous pourrez les identifier et toutes les parties des modèles, en examinant les illustrations séparées des pièces se trouvant dans ce livret.

Même si vous n'avez encore jamais utilisé de Meccano, vous vous rendrez compte qu'avec un peu d'habitude, vous pourrez inventer et construire presque tout ce que vous voudrez. C'est facile, et très amusant. Vous n'avez besoin que d'un tournevis et de deux clés qui sont compris dans chaque jeu. Si vous ne vous êtes encore jamais servi d'outils, voici comment ils fonctionnent.

Le tournevis sert à faire tourner les boulons; on place la pointe dans la fente du boulon et on tourne de gauche à droite. Pour dévisser le boulon, on tourne le tournevis dans l'autre sens.

Les écrous se placent au bout des boulons. Posez l'écrou à l'extrémité du boulon en maintenant avec les doigts, puis utilisez le tournevis pour serrer le boulon.

Pour que l'assemblage soit vraiment solide, maintenez l'écrou avec la clé pendant que vous serrez le boulon.

Quand vous voulez qu'une pièce puisse se mouvoir librement entre un boulon et un écrou, vous pouvez poser un contre-écrou... Il suffit de visser deux écrous sur un boulon et de les serrer l'un contre l'autre.

Lorsque vous construisez des modèles Meccano, vous avez parfois besoin de certains joints standards qui s'appellent Éléments de Base. Numérotés BC1, BC2, etc., ils vous permettront de construire plus facilement tous vos modèles. Ceux qui sont présentés ici conviennent pour les modèles de cette notice.

BC1 Il sert à joindre deux pièces de façon qu'elles puissent bouger. C'est une sorte de contre-écrou. Faites passer un boulon dans les pièces, vissez un écrou sur le boulon (mais sans serrer trop, pour que les pièces puissent bouger), vissez le deuxième écrou et serrez-le à fond contre le premier. Il faut maintenir le premier boulon avec la seconde clé.

BC2 C'est aussi une sorte de contre-écrou. Glissez le boulon dans une des pièces et vissez dessus le premier écrou. Ensuite, glissez la deuxième pièce sur le bout du boulon et vissez dessus le deuxième écrou. Bloquer les écrous contre la deuxième pièce de façon que la première pièce puisse tourner autour des écrous et du boulon.

BC4 C'est une façon de joindre ensemble deux pièces avec deux boulons et deux écrous.



BC15 C'est un collier qui sert de support ou de pallier à un essieu. Le boulon ne doit pas obstruer l'orifice central qui supporte l'essieu, et l'écrou doit être bloqué contre la plaquette ou la lame de support.

Les boulons et écrous s'utilisent différemment selon l'usage qu'on en fait. Ces "montages de boulons" ont été numérotés BF1, BF2, etc., de façon que vous puissiez les identifier sur les

photographies.

Vous remarquerez aussi les symboles

et

Le premier, , indique que les pièces en question doivent pouvoir jouer librement. Le second, , indique que ces pièces doivent aussi pouvoir bouger, mais qu'il doit quand-même y avoir une certaine résistance qui les empêche de jouer complètement, de façon qu'elles restent dans la position que vous désirez.

D So baust Du mit Meccano
Bitte lies dies sorgfältig, bevor Du
mit dem Bauen beginnst

Dieses Buch enthält alle Anleitungen, die Du zum Bauen mit Meccano benötigst. Jedes Modell wird aus Teilabschnitten zusammengesetzt und am Anfang jedes Teilabschnitts ist ein Foto von den besonderen Bestandteilen, die in diesem Teil gebraucht werden. Diese Fotos helfen Ihnen, die benötigten Stücke zu identifizieren. Sie sollten am Anfang zuerst die Bestandteile Ihres Satzes herausuchen, um eine Suche während der Zusammensetzung auszuschalten. Die Folge der Zusammensetzung, z.B. die Aufeinanderfolge von einem Teilabschnitt zum Nächsten in genauer Reihenfolge, sollte nach den gegebenen Illustrationen ausgeführt werden. In den meisten Fällen können die Teile, die in den Modellen gebraucht werden, einfach durch Besichtigung der Illustrationen identifiziert werden, aber sollte die Identität eines Teiles nicht ganz klar sein, ist die Kennnummer des Teiles auf der Illustration angegeben.

Sie können diese und alle Teile der Modelle identifizieren, wenn Sie die einzelnen Zeichnungen der Teile, die in diesem Büchlein gedruckt sind, genau betrachten.

Selbst wenn Du noch nie zuvor mit Meccano gebaut hast, wirst Du feststellen, daß Du nach ein wenig Übung praktisch alles entwerfen und bauen kannst. Es ist leicht—und es macht Spaß. Und die einzigen Werkzeuge, die Du benötigst, sind ein Schraubenzieher und zwei Schraubenschlüssel, die in jedem Baukasten enthalten sind. Vielleicht Du noch nie mit diesen Werkzeugen gearbeitet. In diesem Fall ist die nachstehende kurze Erklärung für Dich bestimmt von Interesse.

Der Schraubenzieher dient zum Drehen der Schrauben. Um eine Schraube anzuziehen, stecke das Blatt einfach in den Schraubenschlitz und drehe es nach rechts. Zum Lösen der Schraube ist der Schraubenzieher nach links zu drehen.

Muttern werden an den Schraubenenden angebracht. Drehe die Mutter zuerst auf das Schraubenende auf und befestige die Schraube dann mit dem Schraubenzieher. Für eine wirklich feste Verbindung halte die Mutter mit dem Schraubenschlüssel fest, während Du die Schraube anziehst.

Wenn Du willst, daß sich ein Teil unbehindert zwischen einer Mutter und einer Schraube bewegt, so kannst Du eine Gegenmutter bilden... Drehe einfach zwei Muttern auf die Schraube auf und ziehe die zweite an, bis sie an der ersten fest anschließt.

Für den Bau von Meccano-Modellen sind mitunter gewisse Normalverbindungen nötig, sogenannte Grundkonstruktionen. Sie sind der Reihe nach BC1, BC2, usw., bezeichnet und man kann damit alle Modelle viel einfacher bauen. Die hier abgebildeten werden für die in diesem Buch gezeigten Modelle benötigt.

BC1 Diese Konstruktion dient zur Verbindung von zwei Teilen, die sich zueinander frei bewegen sollen. Es ist eine Art Gegenmutter. Stecke eine Schraube



durch die Teile, drehe eine Mutter auf die Schraube auf (ziehe sie aber nicht so sehr an, daß sich die Teile nicht bewegen können), drehe die zweite Mutter auf und ziehe sie an, bis sie fest an der ersten Mutter anschließt. Dabei muß Du die erste Mutter mit dem zweiten Schraubenschlüssel festhalten.



BC2 Auch dies ist eine Art Gegenmutter. Stecke die Schraube durch eines der Teile und drehe die erste Mutter auf. Dann schiebe das zweite Teil über das Schraubenende und drehe die zweite Mutter auf. Ziehe die Muttern an das zweite Teil an, so daß sich das erste Teil um die Muttern und die Schraube bewegt.

BC4 So kannst Du zwei Teile mit Hilfe von zwei Muttern und Schrauben miteinander verbinden.

BC15 Ein Bund als Lager oder Stütze für eine Achse. Die Schraube darf die mittlere Bohrung für die Achse nicht behindern und die Mutter ist fest an die Stützplatte bzw. Lasche anzuziehen.

Schrauben und Muttern lassen sich dem jeweiligen Zweck entsprechend auf verschiedene Arten gebrauchen. Diese 'Schraubverbindungen' tragen die Bezeichnungen BF1, BF2, usw. und sind somit in den Abbildungen leicht festzustellen.

Es gibt ferner die Bezeichnungen  und 

Die erste... ... bedeutet, daß die betreffenden Teile frei beweglich sind. Die zweite... ... besagt, daß diese Teile zwar auch beweglich sind aber nur mit einem gewissen Widerstand, so daß sie in einer gewünschten Einstelllage stehen bleiben.

NL Het gebruik van Meccano Lees dit aandachtig voordat je begint te bouwen.

Dit boek bevat al de instructies die je nodig hebt om met Meccano te bouwen. Elk model wordt uit secties samengesteld, aan het begin van elke sectie is er een foto van de bepaalde onderdelen die voor die sectie nodig zijn. Met behulp van deze foto's kunnen de benodigde onderdelen worden herkend. Je moet eerst de onderdelen uit je set uitkiezen, om te voorkomen dat ze gedurende montage moeten worden uitgezocht. De montage volgorde, d.w.z. de vooruitgang van een sectie naar de volgende in de juiste volgorde, moet volgens de afbeeldingen geschieden.

De onderdelen die voor de modellen moeten worden gebruikt kunnen meestal worden herkend door eenvoudig de afbeeldingen te bekijken, maar waar het type onderdeel niet duidelijk is, is het onderdeelnummer op de afbeelding aangegeven.

Je kan deze herkennen en ook alle andere onderdelen in de modellen door de afzonderlijke afbeeldingen van onderdelen te bestuderen die in dit boekje zijn opgenomen.

Zelfs als je nog nooit Meccano gebruikt hebt, zul je merken dat je met een klein beetje oefening bijna alles kunt ontwerpen en bouwen. Het is eenvoudig—en het is leuk. Het enige gereedschap dat je nodig hebt is een schroevendraaier en twee moersleutels en die bevinden zich in elk pakket. Voor het geval je nog nooit gereedschap gebruikt hebt volgen hier een paar aanwijzingen.

De schroevendraaier wordt gebruikt om bouten aan te halen door het blad in de sleuf van de bout te plaatsen en deze naar rechts te draaien. Om de bout los te maken draai je de schroevendraaier in tegenovergestelde richting.

Moeren passen aan de uiteinden van

bouten. Gebruik je vingers om de moer aan het uiteinde van de bout te plaatsen en neem dan de schroevendraaier om de bout aan te halen. Om een werkelijk stevige verbinding te krijgen houd je de moer met de sleutel vast terwijl je de bout aandraait.

Als je een onderdeel vrij tussen een moer en een bout wilt laten bewegen kun je een borgmoer maken . . . je zet eenvoudig twee moeren op een bout en draait ze tegen elkaar vast.

Wanneer je Meccano-modellen bouwt, heb je soms bepaalde standaardverbindingen, zgn. basisconstructies, nodig. Deze zijn genummerd BC1, BC2, enz. en zullen je helpen al je modellen gemakkelijker in elkaar te zetten. De hier aangeduide basisconstructies zijn nodig voor de modellen in dit boek.

BC1 verbindt twee strips zodat zij kunnen bewegen. Het is een soort borgmoer. Je drukt een bout door de strips, zet een moer op de bout (maar draai deze niet zo stevig op dat je de strips niet kunt bewegen), zet een tweede moer op en draai deze tegen de eerste vast. Je zult de eerste moer met de tweede sleutel moeten vasthouden.



BC2—dit is een ander soort borgmoer. Druk de bout door een van de strips en zet de eerste moer erop. Druk dan de tweede strip over het uiteinde van de bout en zet de tweede moer erop. Draai de moeren tegen de tweede strip aan zodat de eerste strip om de moeren en de bout beweegt.



BC4—dit is een manier om met twee moerem en bouten twee strips te verbinden.

BC15 is een kraag die gebruikt wordt om een lager of een steun voor een as te vormen. De bout mag het middenste gat waar de as doorheen steekt niet versperren en de moer dient tegen de steunplaat of strip vastegezet te worden.

Bouten en moeren kunnen op verschillende manieren voor verschillende

taken worden gebruikt. Deze "boutbevestigingen" zijn BF1, BF2 enz. genummerd, zodat je ze van de foto's kunt herkennen.

Je zult ook de symbolen  en  aantreffen.

Het eerste, duidt aan dat de betrokken  onderdelen vrij zullen bewegen. Het tweede, , duidt aan dat deze onderdelen wel zullen bewegen maar dat er enige weerstand tegen een volkomen vrije beweging optreedt, zodat de onderdelen in de gewenste stand zullen blijven.

N **Hvordan du bruker Meccano** **Les nøye gjennom disse** **anvisningene for du tar til med å** **bygge noe**

Dette heftet inneholder alle de opplysningene du trenger for å bygge med Meccano. Hver modell settes sammen i seksjoner og ved begynnelsen av hver seksjon finnes det et fotografi av de delene som danner den seksjonen. Disse fotografiene vil hjelpe deg til å identifisere de deler du trenger. Ta delene du trenger opp av esken før du begynner å bygge da går byggingen lettere unna. Se godt på illustrasjonene og følg byggerekkefølgen, dvs. den gradvise utvikling fra en seksjon til den neste i riktig rekkefølge.

I de fleste tilfelle kan de deler du bruker i modellene lett gjenkjennes bare ved å se på illustrasjonene, men hvor identiteten av en del ikke er helt klar står delnummeret merket av på illustrasjonene.

Du blir i stand til å identifisere disse og alle delene i modellene ved å se på de individuelle bildene av delene som står i denne vesle boken.

Selv om du aldri har brukt Meccano før, så finner du snart, etter bare litt øvelse, at du kan konstruere og bygge nesten hva som helst. Det er lett—og det er moro. Og

den eneste form for verktøy du trenger er en skrutrekker og to skrunøkler—og disse tre følger med hvert eneste sett. Og—i tilfelle du ikke har brukt noe verktøy tidligere—det er slik du bruker dem:

Skrutekkeren brukes for å trekke til skruer—dette gjør du ganske enkelt ved å sette bladet på skrutrekkeren inn i sporet i hodet på skruen og dreie skrutekkeren mot høyre. Hvis du ønsker å skru en skrue ut igjen, dreier du bare skrutrekkeren den andre veien.

Mutrene settes inn over enden av skruene. Bruk fingrene først til å skru mutrene på med, deretter skrutrekkeren for å feste skruen litt til.

For at det hele nå skal sitte riktig godt fast bør du holde mutteren fast ved hjelp av skrunøkkelen, samtidig som du trekker skruen til med skrutrekkeren.

Hvis du ønsker at en eller annen del skal løpe eller dreie fritt mellom en mutter og en skrue, kan du lett lage til en låsemutter . . . Bare skru to mutre inn på en skrue og trekk disse mutrene til mot hverandre.

Når du skal bygge Meccano modeller vil du som oftest trenge visse standard deler til å sette dem sammen. De kalles her Basic Constructions og er nummerert BC1, BC2, osv. De vil hjelpe deg til lettere å bygge alle modellene, og de som vises her er de du trenger til å bygge modellene i denne boken.

BC1 Denne skjoter to deler sammen slik at de kan bevege seg. Det er en slags låsemutter. Skyv en skrue gjennom delene, skru en mutter inn på skruen (men trekk den ikke så meget til at delene ikke kan bevege seg), skru deretter på en mutter til og trekk denne til mot den første. For å gjøre dette må du holde den første mutteren i ro med skrunøkkel nr. to.



BC2 Dette er en annen slags låsemutter. Skyv skruen gjennom en av delene og skru den første mutteren på. Skyv så del nr. to inn over den av skruen og deretter den



andre mutteren. Trekk mutrene til mot del nr. to slik at del nr. en kan dreie rundt mutrene og skruen.

BC4 Ved hjelp av to mutre og skruer kan du skjote to deler sammen på denne måten.

BC15 Dette er en ring som blir brukt til å forme et lager eller støtte for en aksel. Bolten må ikke stenge for hullet i midten som akselen går gjennom og mutteren må festes mot støtteplaten.

Bolter og muttere kan brukes på forskjellige måter til forskjellige ting. Disse kombinasjonene er nummerert BF1, BF2, osv. så det er lett for deg å finne dem i illustrasjonene.

Du vil også finne tegnene  og .

Det først tegnet, , betyr at delene vil bevege seg fritt. Det andre tegnet, , betyr at disse delene også vil kunne bevege seg, men de beveger seg ikke like fritt som de merket 000 og kan derfor stoppes i hvilken som helst stilling.

I **Come si costruisce col Meccano** **Prima di iniziare la costruzione dei** **modelli leggete attentamente** **quanto segue.**

Il presente manuale contiene tutte le istruzioni necessarie per costruire i modelli Meccano. Ogni modello è montato a sezione e, all'inizio di ogni sezione, c'è una fotografia dei precisi componenti usati in quella sezione. Queste fotografie ti aiuteranno a riconoscere le parti che occorrono. Tu dovresti prima selezionare i pezzi della tua collezione per evitare di cercarli quando li assembli. La successione dell'assemblaggio, cioè, proseguendo da una sezione all'altra nell'ordine corretto, dovrebbe essere imitata come mostrata sulle illustrazioni.

In molti casi, le parti usate nei modelli si possono riconoscere guardando

semplicemente le illustrazioni, ma dove l'identità di una parte potrebbe essere non chiara, il numero della sua parte è segnato sulle illustrazioni. Potrai distinguere queste e tutte le parti dei modelli, studiando i quadri singoli delle parti stampate in quest'opuscolo.

Anche se vi cimentate per la prima volta con il Meccano constaterete che, con un pochino di pratica, riuscirete a progettare, e realizzare qualsiasi tipo di costruzione. E' facile e divertente. Occorrono semplicemente il cacciavite e le due chiavi per dadi che troverete nel corredo. Se non avete mai usato questi utensili in precedenza, seguite queste istruzioni.

Il cacciavite serve per avvitare le viti; inserite la punta dello stesso nel taglio sulla testa della vite e girate in senso orario. Per allentare una vite, girate il cacciavite nel senso contrario.

I dadi si avvitano alle viti per unire insieme i pezzi Meccano. Si comincia girando con le dita il dado, in senso orario, sul gambo della vite. Quindi si usa la chiave per stringere bene il dado. Se alle volte il dado e la vite girano insieme, inserite la punta del cacciavite nel taglio della vite tenendo fermo e con la chiave stringete strettamente il dado. Può essere talvolta più facile tenere fermo il dado con la chiave e avvitare la vite con il cacciavite.

Le due chiavi per dadi contenute nella scatola servono per realizzare il "controdado", avvitate due dadi sul gambo di una vite e stringeteli strettamente l'uno contro l'altro, lasciando tra i dadi e la testa della vite lo spazio utile per il libero movimento di un braccio articolato.

Nella costruzione di modelli Meccano alle volte sono necessarie delle giunzioni di vari tipi, indicate nei manuali Meccano come "costruzioni di base Meccano" ciascuna con una sigla di riferimento. Sarebbe utile fare una certa pratica con queste giunzioni perchè se imparate a realizzarle con cura, vi sarà più facile poi

costruire i vostri modelli Meccano.

BC1 E' il modo di congiungere due strisce permettendone l'articolazione. Questo congegno in meccanica è chiamato "controdado". I due dadi, sulla vite di congiunzione, sono stretti uno contro l'altro in modo da non premere contro la striscia; le due strisce devono poter muovere liberamente sul gambo della vite.



BC2 E' un'altra applicazione del controdado. Un dado è avvitato al di sopra di una delle strisce e l'altro dado è avvitato al di sotto. I due dadi sono poi stretti contro la striscia mentre l'altra resta libera di girare sul gambo della vite.

BC3 Questa è semplicemente la congiunzione di due strisce per mezzo di una terza striscia. Due viti e due dadi possono bastare per avvitare le tre strisce insieme, ma quattro formano una congiunzione più solida.

BC4 Questo è il modo di unire due strisce insieme mediante due viti e relativi dadi. Se viene usata una sola vite con il rispettivo dado le strisce potrebbero muoversi.

BC15 Si tratta di un collare usato per formare un cuscinetto o supporto per un asse. La vite non deve ostruire il foro centrale che porta l'asse e il dado deve essere stretto contro la striscia o piastra di supporto.

I dadi e le viti possono venir usati in diversi modi, a seconda del lavoro. Queste varie combinazioni di impiego delle viti sono state numerate BF1, BF2, ecc. in modo che potrete riconoscerle con facilità osservando le illustrazioni.

Noterete anche i simboli  e .

Il primo, , indica che le parti possono muovere liberamente.

Il secondo, , indica che le parti potranno anche muovere, incontrando però un certo attrito che permette loro di rimanere ferme in qualsiasi posizione desiderata.

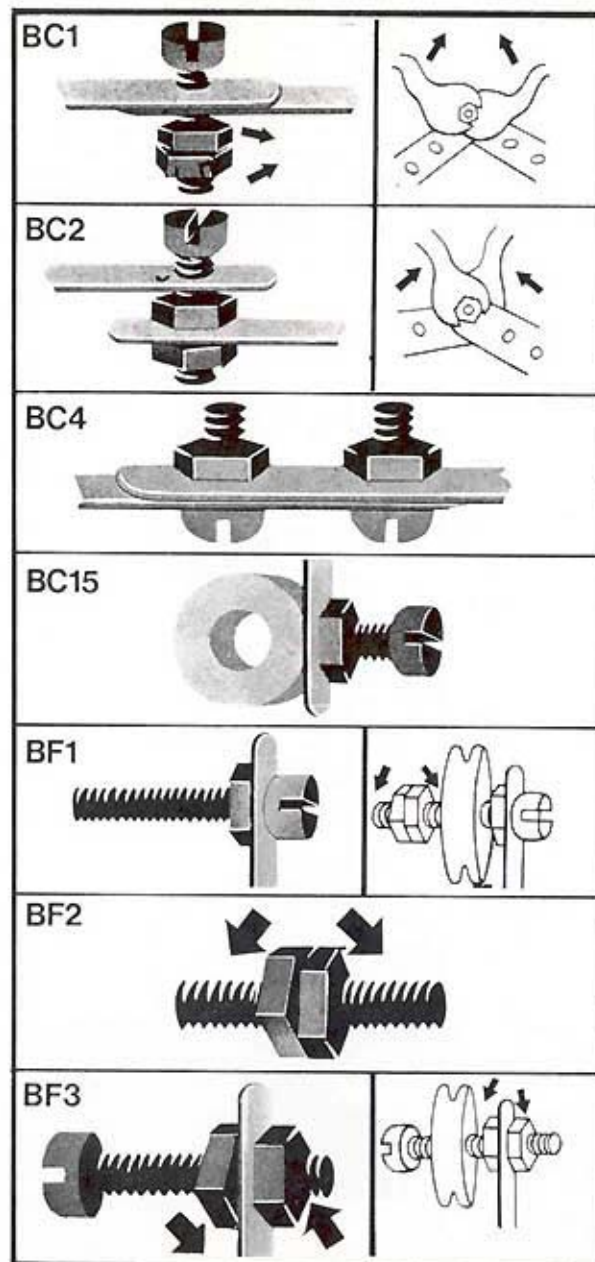

GB

YOUR ELECTRIC MOTOR

This Meccano set includes a 4½ volt DC motor (A), a forward and reverse motor control unit (B), a coil of connecting wire (C) and four plugs (D)

You will need to obtain three HP 11 Batteries or their equivalent.

1. Remove base from control unit by turning a coin in the slot. 2. Insert the batteries the correct way round as shown on the base, and refit the lid. 3. Cut the wire into two equal lengths and remove about 1 cm of insulation from each end. 4. Slide the plug body downwards to expose pin, thread bared end of wire through the eye, about 5 mm, slide body upwards to trap the wire. 5. Insert the plugs from each wire into the motor end plate and the other plugs into one side only of control unit. 6. To start motor, switch 'on' at both control unit and motor. Moving either switch in the opposite direction will reverse the drive.

F

VOTRE MOTEUR ELECTRIQUE

Ce jeu de Mécano comprend un Moteur DC de 4,5 voltes (A), un groupe de commande avant et arrière (B), une bobine de fil de connexion (C) et quatre fiches (D)

Vous aurez besoin de trois piles HP 11 ou équivalentes.

1. Pour enlever la base de l'unité de contrôle, faire tourner la fente à l'aide d'une pièce. 2. Placer les piles, la position correcte est illustrée sur le fond, et replacer le couvercle. 3. Couper le fil en deux longueurs égales et enlever environ 1 cm d'isolant à chaque bout.

4. Glisser le corps de la fiche vers le bas pour faire sortir la pointe, passer le fil nu dans le trou, environ 5 mm, retirer le corps vers le haut pour coincer le fil. 5. Introduire les fiches provenant de chaque fil dans la plaque du moteur et les autres fiches sur un seul côté du groupe de commande. 6. Pour mettre le moteur en marche, placer le switch sur 'on' au groupe de commande ainsi que sur le moteur. Le déplacement du switch dans la direction opposée renversera la transmission.

D

IHR ELEKTROMOTOR

Dieser Meccanosatz schliesst einen 4½ Volt Gleichstrommotor (A), eine Vörwärts- und Rückwärtskontroll-einheit (B), eine Spule Verbindungsdraht (C) und vier Stecker (D), ein.

Sie müssen drei HP 11 Batterien oder ihr Äquivalent verschaffen.

1. Entferne das unterteil vom kontrollteil durch drehen des schlosses mit einer muenze. 2. Setzen Sie die Batterien ein; die genaue Lage ist auf der Basis angegeben, und schließen Sie den Deckel wieder. 3. Schneiden Sie den Draht in zwei gleichmässige Längen und entfernen Sie ungefähr 1 cm der Isolierung von jedem Ende. 4. Lassen Sie den Steckerkörper heruntergleiten, um die Nadel frei werden zu lassen, fädeln Sie das blosse Drahtende durch das Öhr, ungefähr 5 mm, schieben Sie den Körper nach oben, um den Draht festzuhalten. 5. Setzen Sie die Stecker jedes Drahtes in die Motorkopfplatte ein und die anderen Stecker

in nur eine Seite der Kontrolleinheit. 6. Um den Motor zu starten, stellen Sie auf "an", sowohl bei der Kontrolleinheit, wie beim Motor. Wenn einer der beiden Schalter in entgegengesetzter Richtung bewegt wird, wird die Antriebsrichtung umgekehrt.

NL

JE MOTOR

Deze Meccano set bevat een 4½ volt gelijkstroom motor (A), een motorregelapparaat vooruit/achteruit (B), een spoel aansluitingsdraad (C) en vier stekertjes (D)

Je moet drie HP 11 of soortgelijke batterijtjes erbij kopen.

1. Verwijder deksel door een geldstuk in de gleuf te steken en deze vervolgens te draaien. 2. Zet de batterijtjes in de juiste stand zoals op het voetstuk is aangegeven erin en zet het dekseltje weer terug. 3. Knip het draad op twee stukken van gelijke lengte en verwijder ca. 1 cm isolatie van elk der einden. 4. Schuif de huls van de stekker omlaag zodat de pen wordt blootgesteld, steek het blote draadeind ongeveer 5 mm door de oog, schuif de huls omhoog zodat de draad wordt vastgeklemd. 5. Steek de stekkers aan beide draadstukken in de achterplaat van de motor en de stekkers aan de andere einden in slechts een zijde van het regelapparaat. 6. Om de motor aan te zetten, moet zowel het regelapparaat als de motor worden ingeschakeld. Door een der beide schakelaars om te schakelen, loopt de motor in de andere richting.

I

IL TUO MOTORE ELETTRICO

Questa collezione del Meccano include un motore con voltaggio DC 4½ (A), un motore reparto controllo avanti e indietro (B), una bobina di filo d'induzione (C), e quattro spine (D)

È necessario che tu ti provveda di tre pile HP 11, o equivalenti ad esse.

1. Per togliere la base della scatola portapile girare con una moneta inserita nella fessura. 2. Inserisci le pile, la maniera corretta è mostrata sulla base, e rimetti il coperchio. 3. Taglia il filo elettrico in due lunghezze eguali e rimuovi circa cm 1 d'isolante da ogni estremità. 4. Tira in giù la cassetta della spina per esporre lo spillo, infila nell'occhio l'estremita scoperta del filo di circa 5 mm, tira in su la cassetta per tenere in trappola il filo. 5. Inserisci le spine di ogni filo nell'estremità della piastra del motore, e le altre spine in un lato solo del reparto controllo. 6. Per accendere il motore, accendi tutti e due il reparto controllo e il motore. Muovendo sia l'una che l'altra chiavetta nella direzione opposta si invertirà l'energia.

N

DIN ELEKTRISKE MOTOR

Denne Meccano-sættet inneholder en 4½ volt likestrømsmotor (A), en kontrollenhet (B) som regulerer motorens rotasjonsretning, en spoel med ledning (C) og fire plugger (D)

Du trenger tre HP 11 batterier eller tilsvarende for å drive motoren.

1. Plattformen løsnes fra kontrollenheten ved å sette en mynt i slissen og vri. 2. Legg batteriene på plass, pass på at de ligger riktig vei, se skissen på bunnen av enheten, legg lokket tilbake. 3. Del ledningen opp i to like store lengder og skrap ca. 1 cm av isolasjonen av hver ende. 4. Skyv pluggen ned slik at selve pinnen blir blottlagt, stikk den uisolerte enden av ledningen gjennom øyet, ca. 5 mm, skyv selve pluggen opp slik at ledningen holdes fast. 5. For pluggene fra hver ledning inn i motorens endeplate og de andre pluggene bare inn i den ene siden av kontrollenheten. 6. For å starte motoren slår du både kontrollenheten og motoren på. Om du nå vrir på en av bryterne vil motoren dreie i motsatt retning.

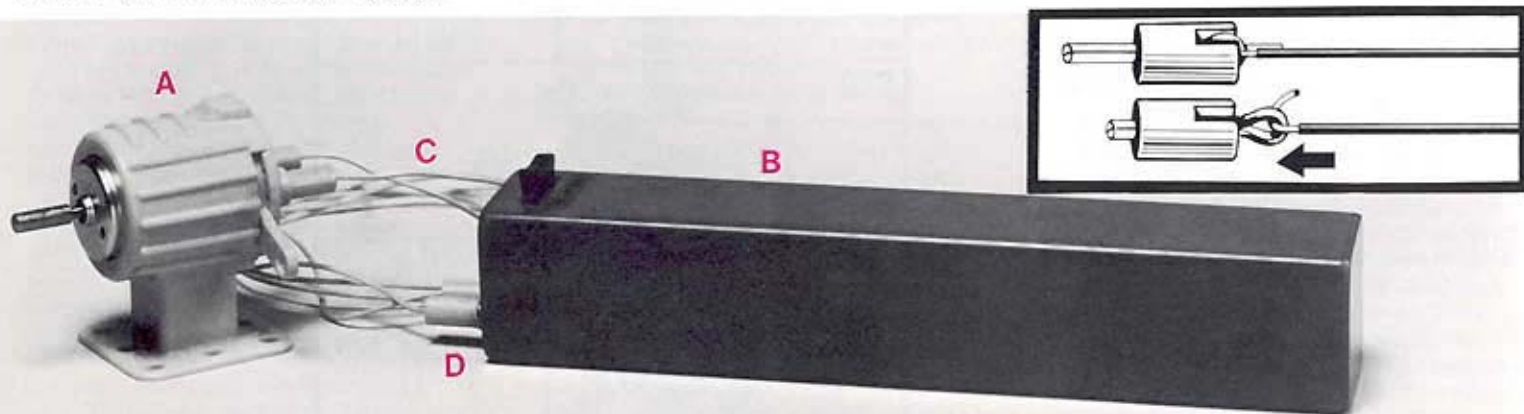

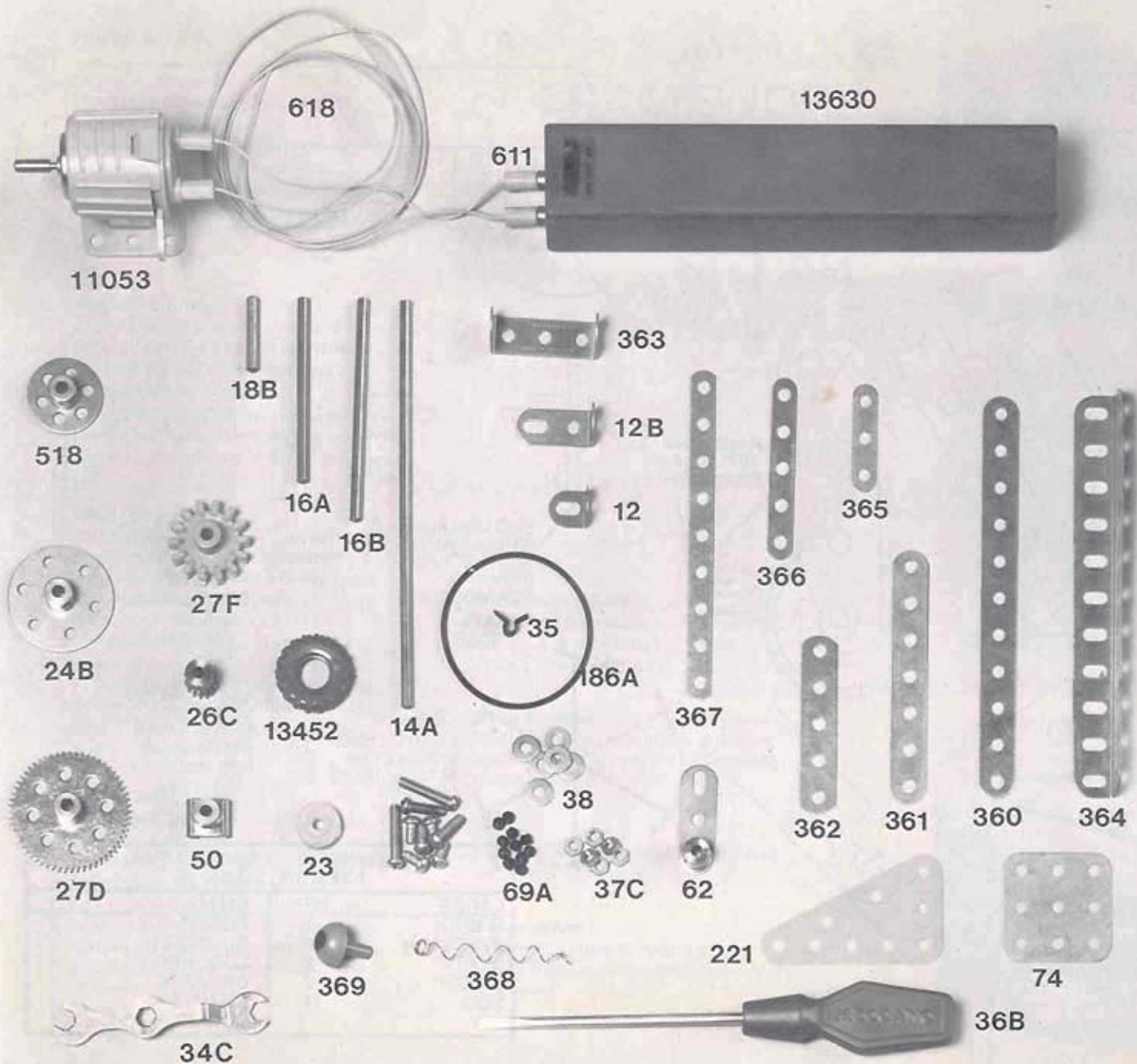

PART No.	DESCRIPTION	QTY.
360	5 1/2" Strip	2
361	3 1/2" Strip	8
362	2 1/2" Strip	6
364	Angle Girder 5 1/2"	2
12	Angle Bracket 1/2" x 1/2"	6
12B	Angle Bracket 1 1/2" x 1/2"	2
14A	Axle Rods 5 1/2"	2
16A	Axle Rod 2 1/2"	3
16B	Axle Rod 3"	2
18B	Axle Rod 1"	2
23	Plastic Pulley 1/2"	4
13452	Tyre for 1/2" Pulley	4
24B	Bush Wheel 6 Hole Large	2
518	Bush Wheel Small	2
26C	Pinion 7/16" x 1/4"	2
27D	Gear Wheel 60T	2
27F	Gear Wheel M/Purpose	1
35	Spring clip	17
37B	Bolt 1/4"	50
37C	Nut	60
38	Washer 3/8"	20
363	Double Angle Strip 1 1/2"	4
50	Slide Piece	2
62	Single Arm Crank	2
74	Flat Plate 1 1/2" x 1 1/2"	2
69A	Grub Screw 3/32"	20
111	Bolt 3/4"	2
111A	Bolt 1/2"	4
186A	Drive Band 6" Light	2
221	Triangular Flex Plate 2 1/2" x 1 1/2"	2
365	Narrow Strip 1 1/2"	6
366	Narrow Strip 2 1/2"	4
367	Narrow Strip 4 1/2"	6
11053	Electric Motor 4 1/2 v	1
359	Sheet of Self Adhesive Labels	1
368	Spring	3
369	Eye	3
13630	Battery Box	1
36B	Screwdriver	1
34C	Spanner	2
618	Connecting Wire	1
611	Plugs	4

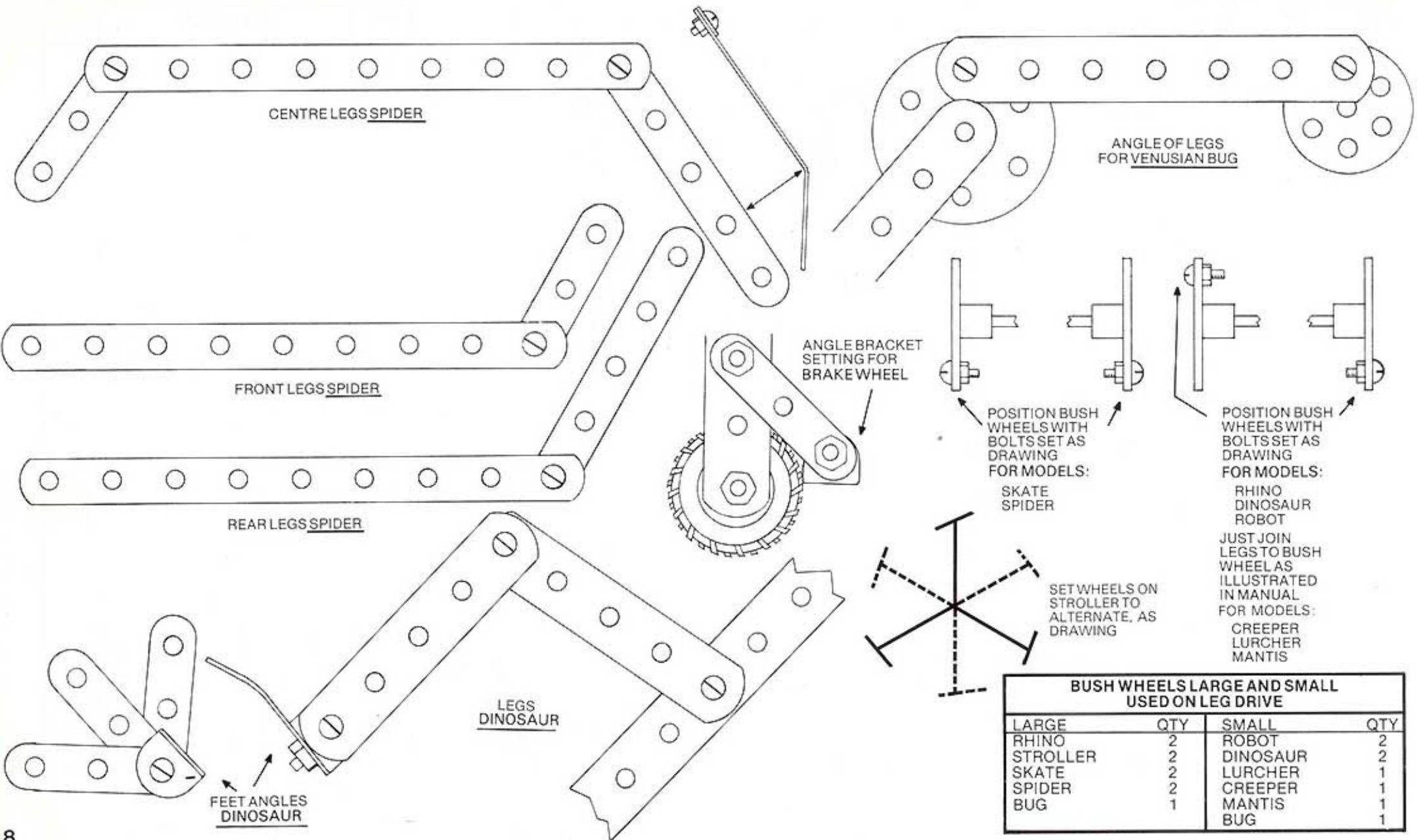

HINTS & TIPS

1. Motor Framework

This is the power base for your models and the single framework is common to all. Once built and tested for smooth running any of the Meccanoids can be built around it. Remove the parts from the model last built and the base is ready for your next model.

2. Angle Settings

Study the diagrams on page 8 carefully in conjunction with the photographs of the Meccanoid you have chosen to build.

Lightly tighten the parts required, lay them on the diagrams and set the angles correctly, then firmly tighten.

3. Working Parts

All working parts should be correctly spaced to ensure free movement. To help you space parts correctly, cut a strip of thin card two inches long by half an inch wide and insert it between any parts that should be assembled adjacent to each other. When the appropriate bolts or grub screws have been tightened the card should slide out, if not you have spaced the parts too closely.

4. Brake Wheel

The brake wheel as illustrated on page 8 should rotate freely when the Meccanoid is moving forward but should lock to prevent reverse movement by means of the angle bracket biting into the tyre tread. Before fitting this assembly to model ensure that the wheel turns in one direction only.

MOTOR FRAMEWORK CONSTRUCTION * COMMON TO ALL MODELS

5. Spare Axle Rods

These can be used to position pieces correctly (by aligning the holes) before final tightening.

6. Grub Screws

Fit grub screws into gears, pinions, bush wheels etc. before assembling these parts in model.

7. Oiling

Lightly oil axle bearings and moving parts, but do not over-oil.

8. Screwdriver

Besides tightening bolts your screwdriver makes a good reamer, or tyre lever.

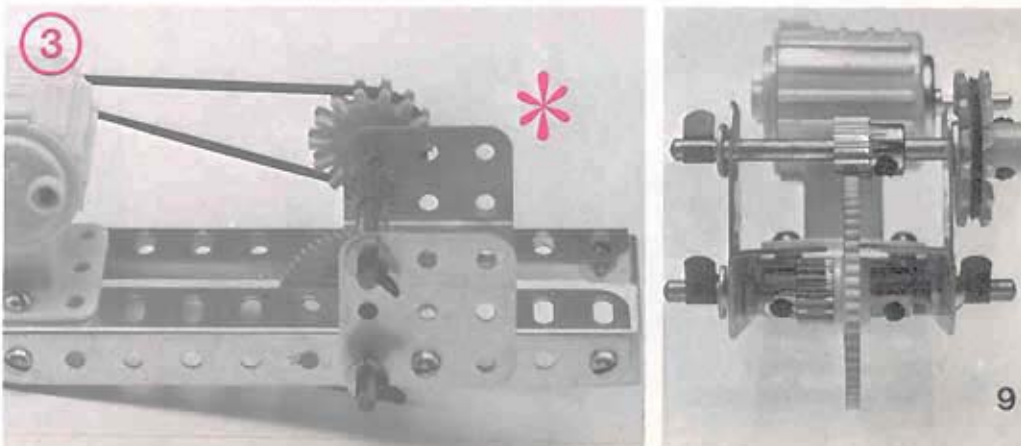
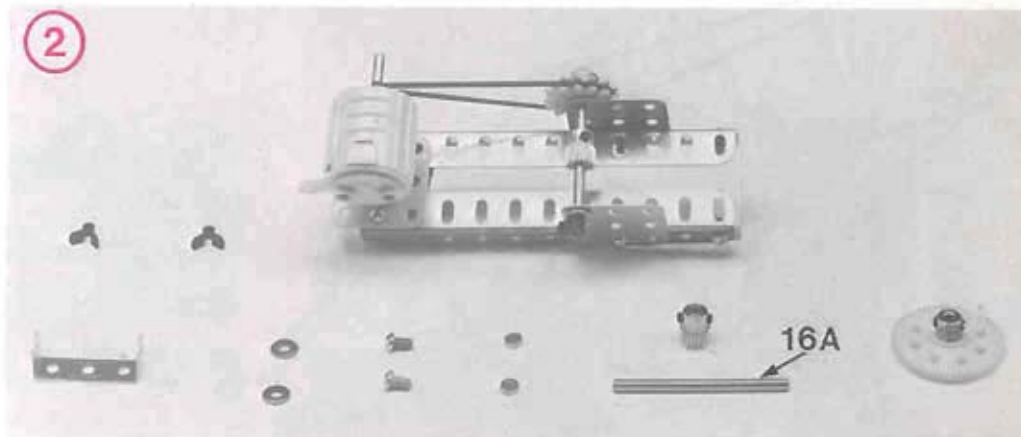
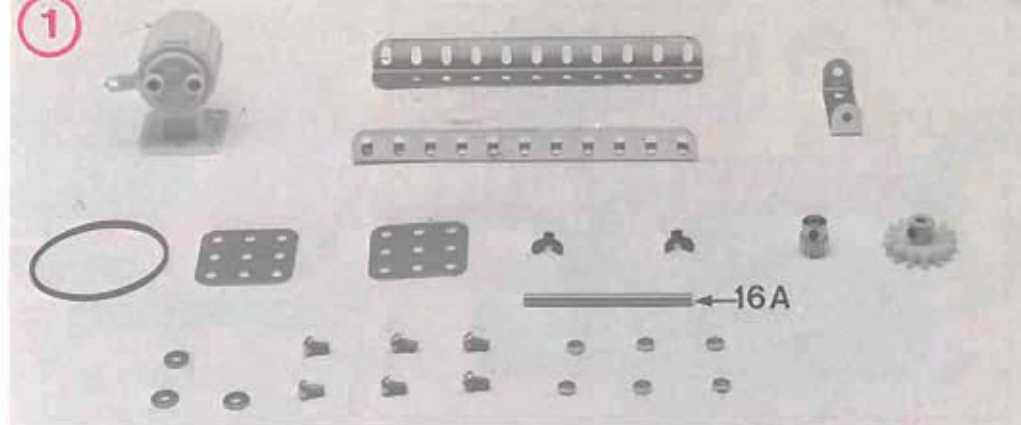

Venusian Desert Bug

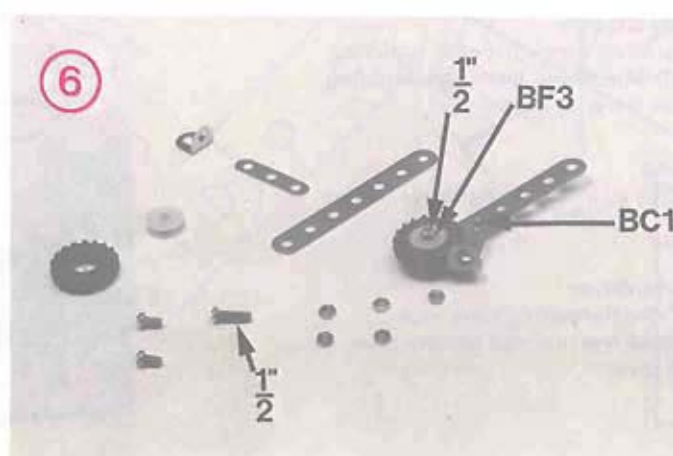
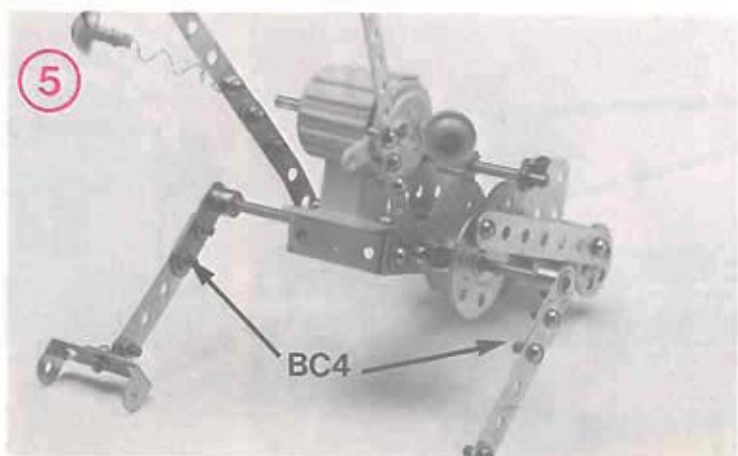
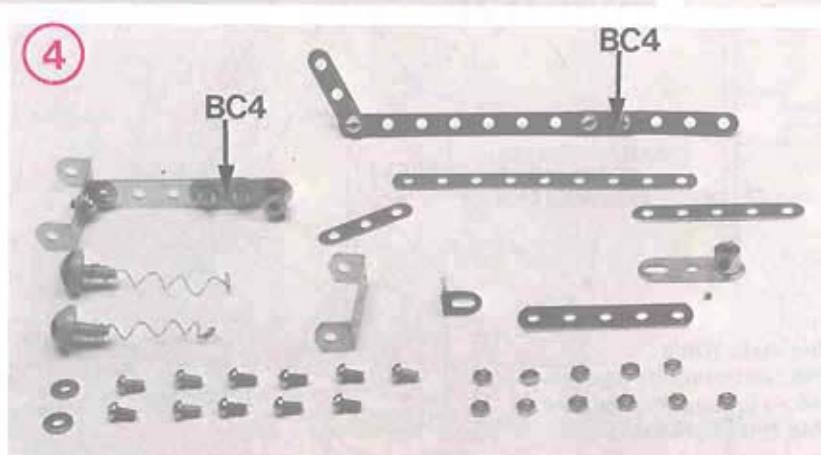
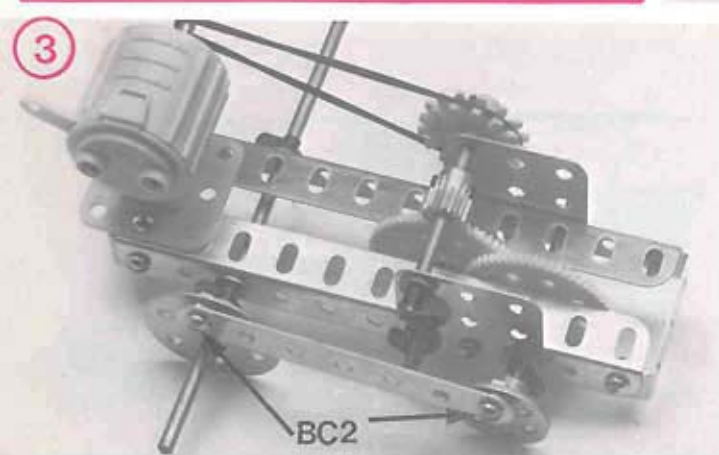
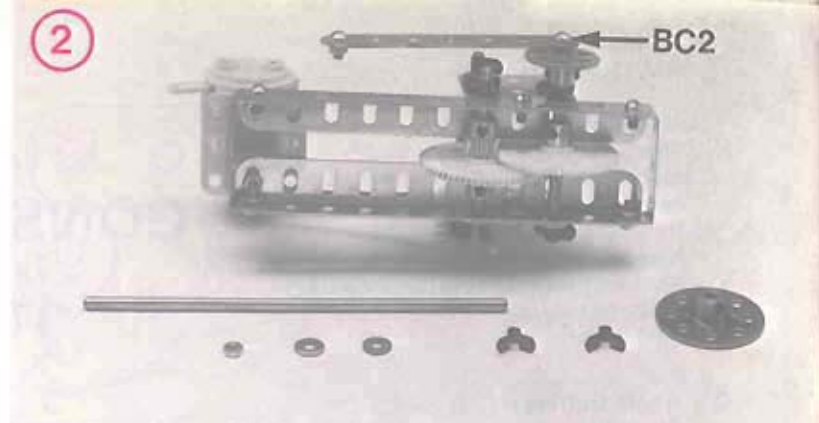
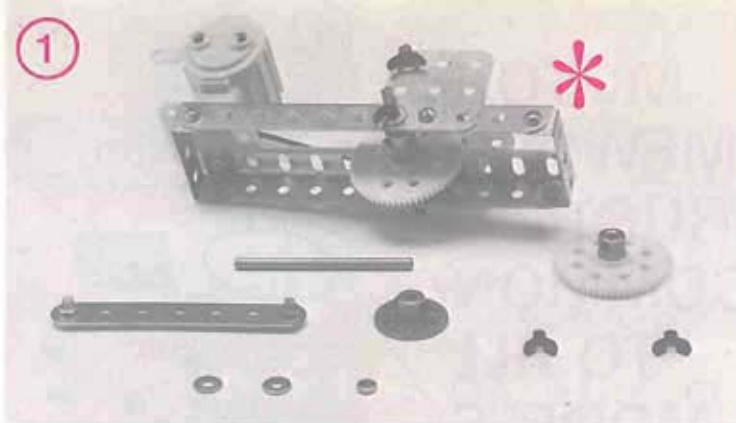

Sirius Stroller

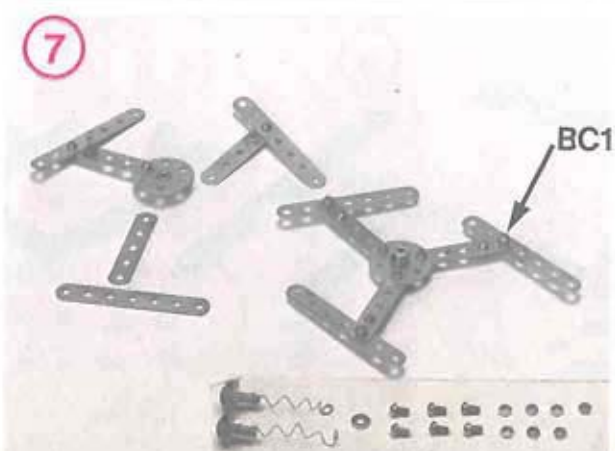
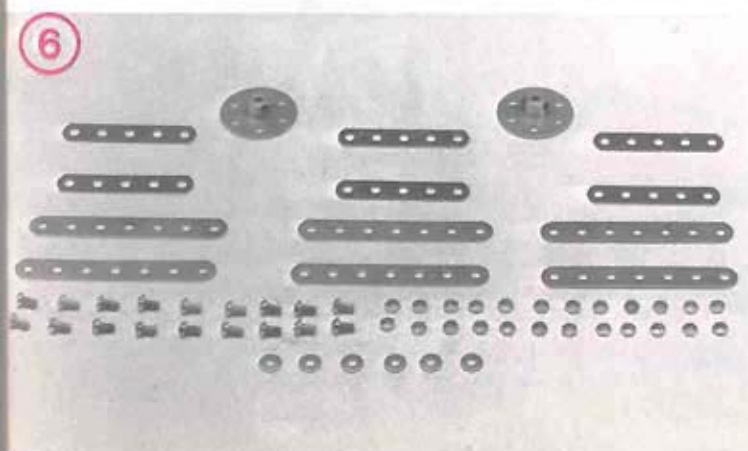
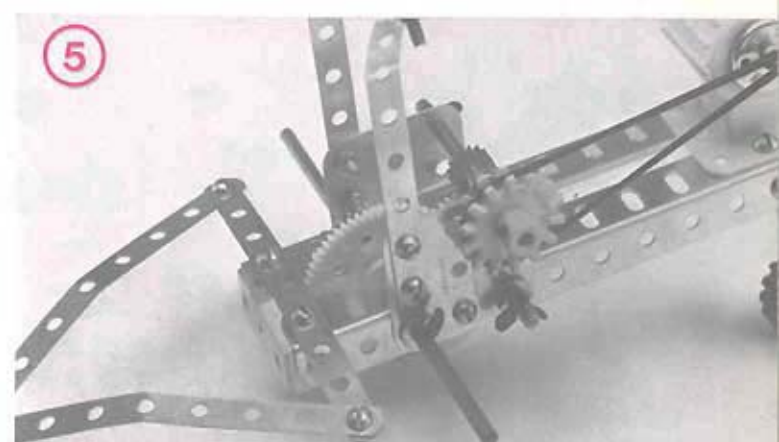
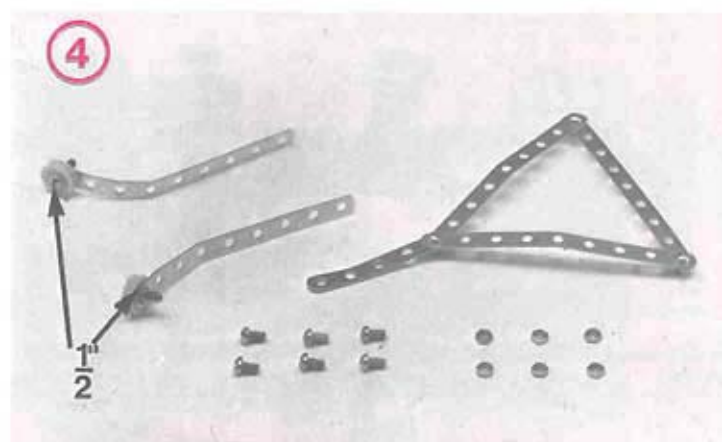
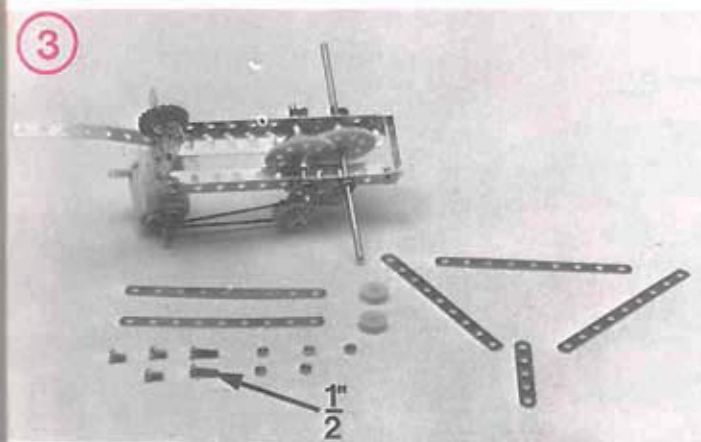
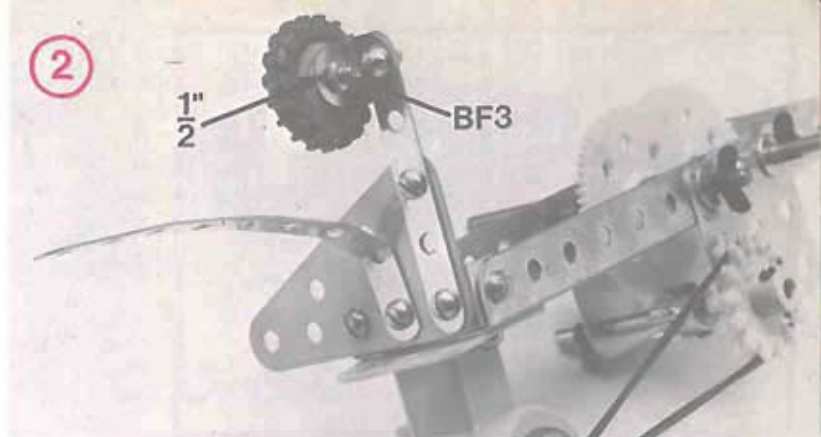
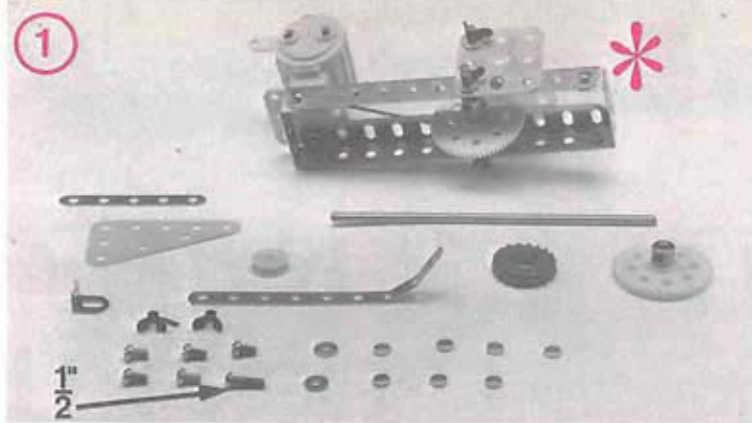

Saturn Dinosaur

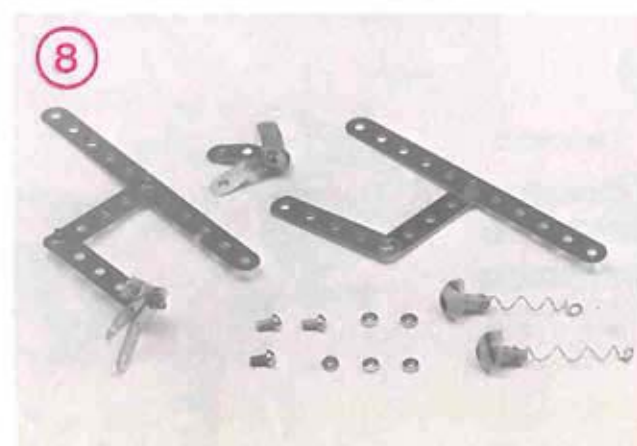
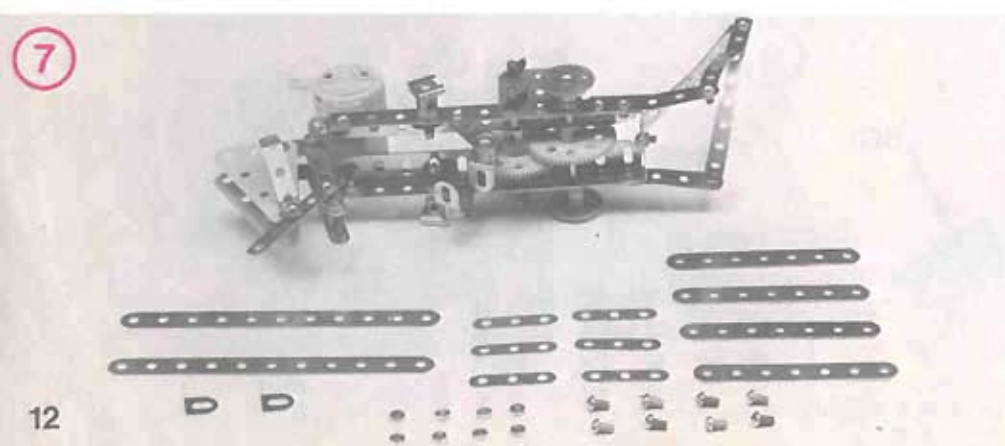
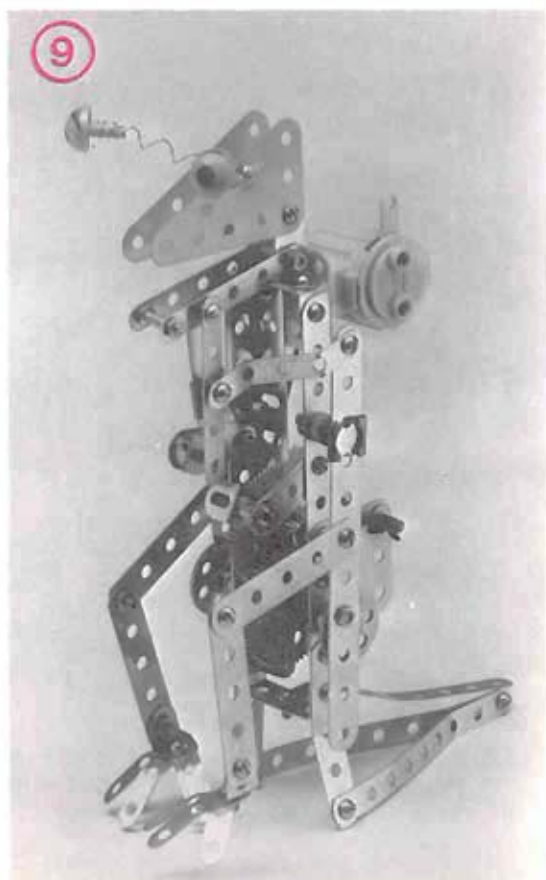
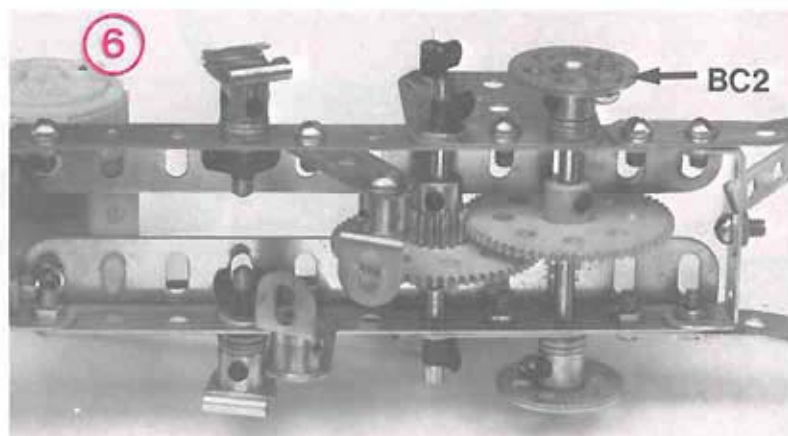
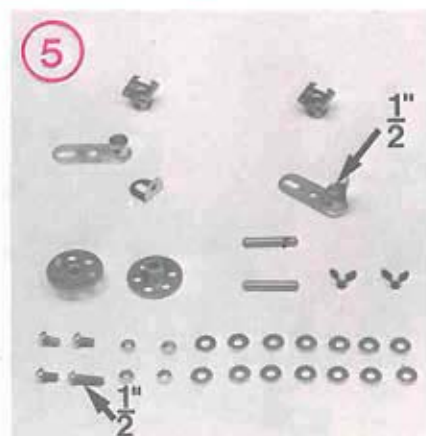
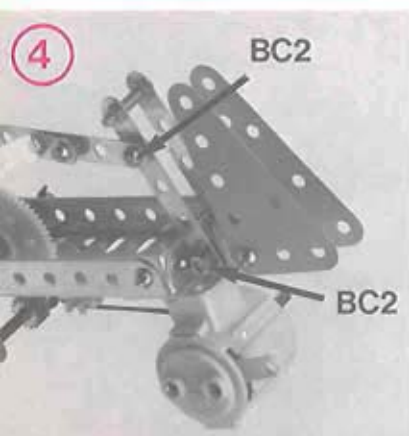
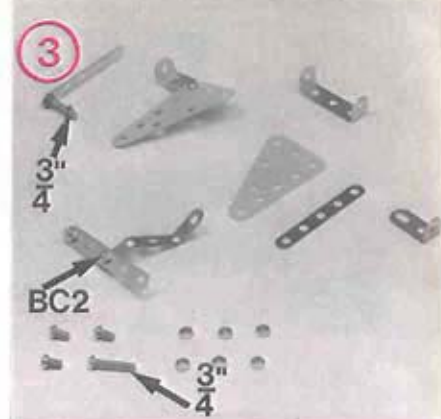
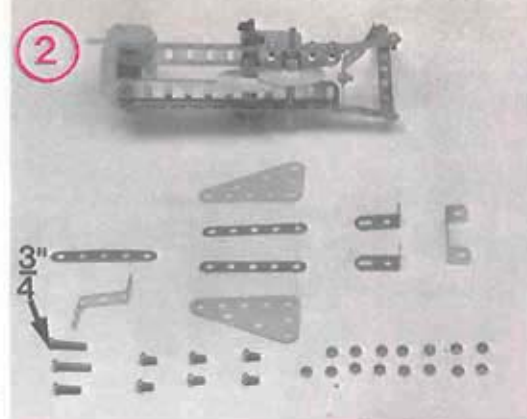
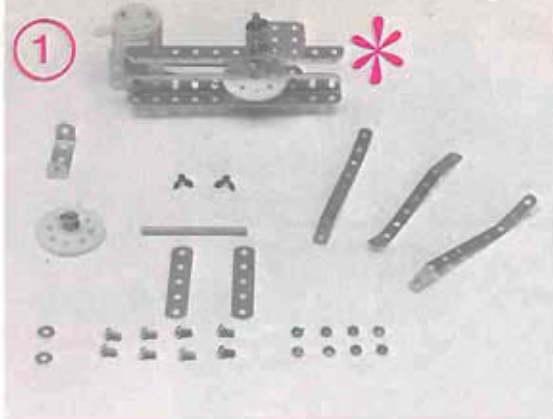

Martian Mantis

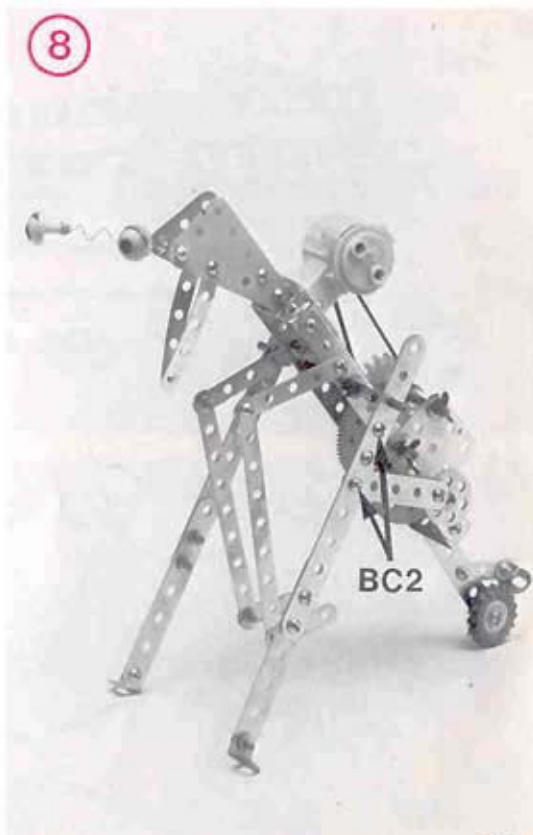
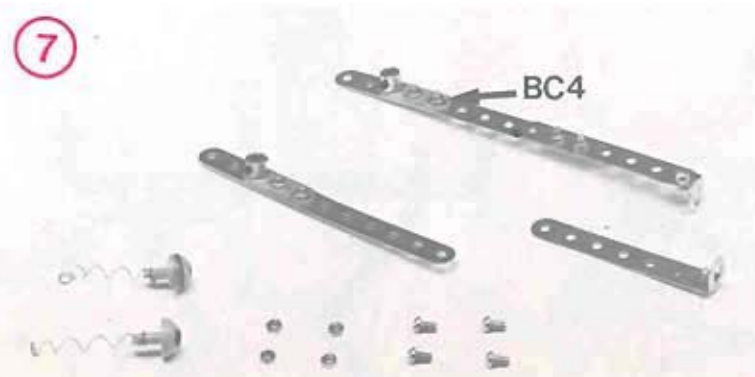
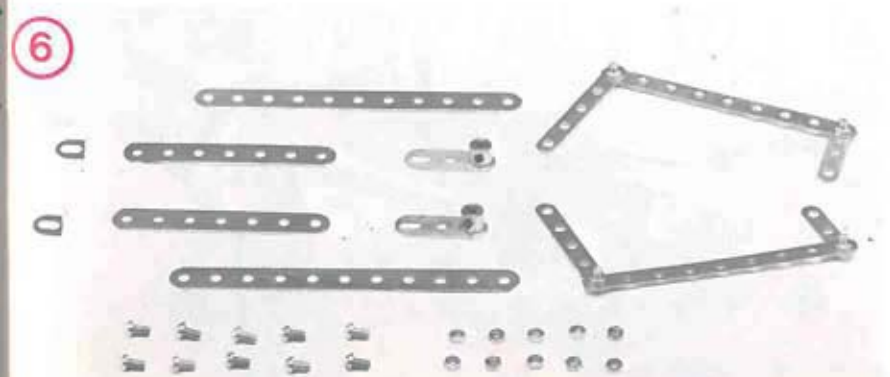
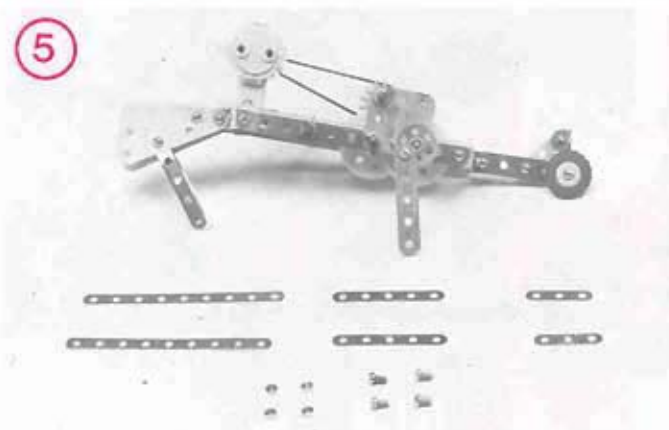
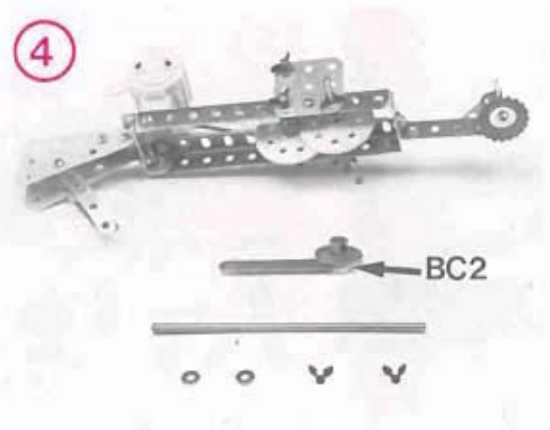
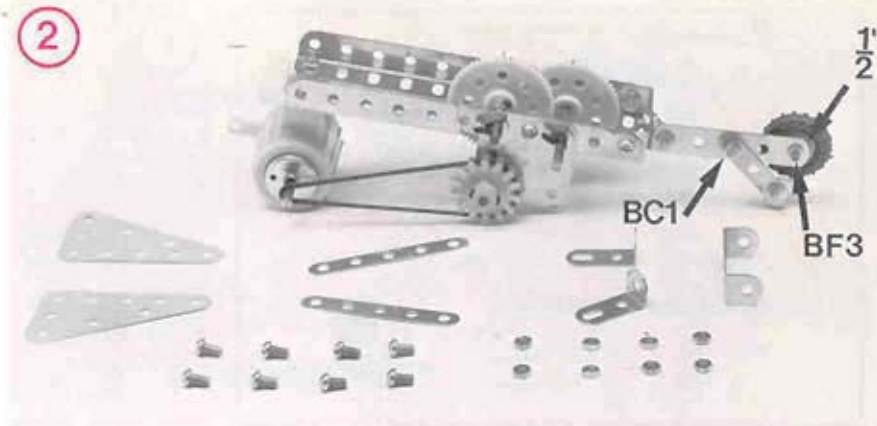
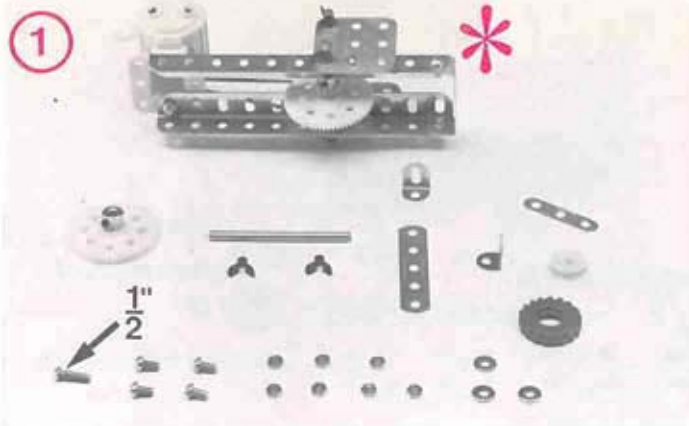

Space Skate

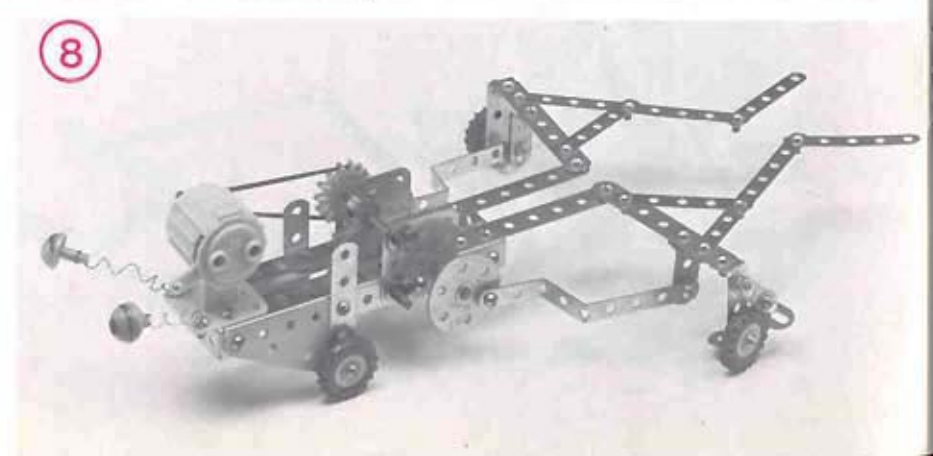
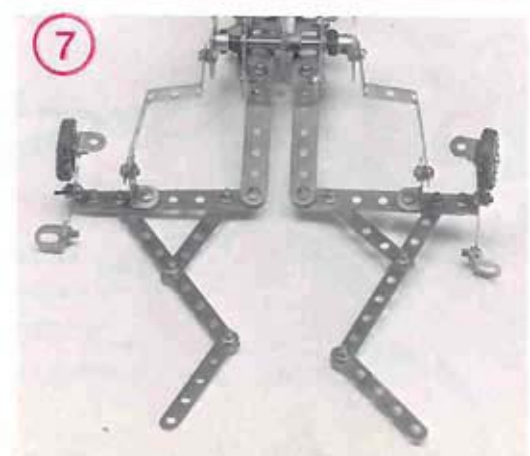
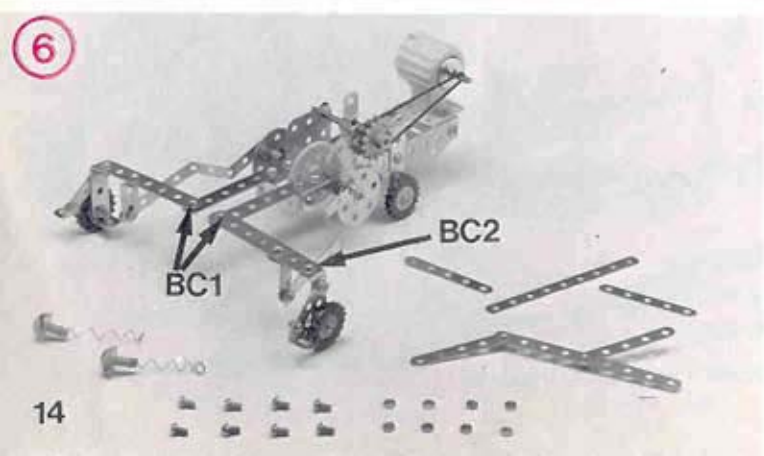
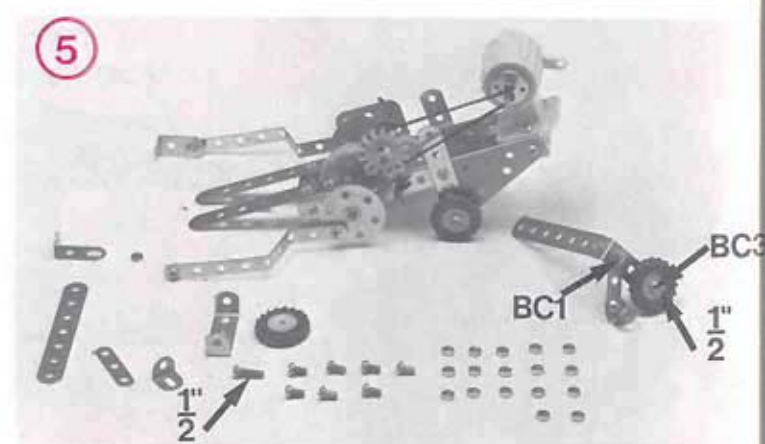
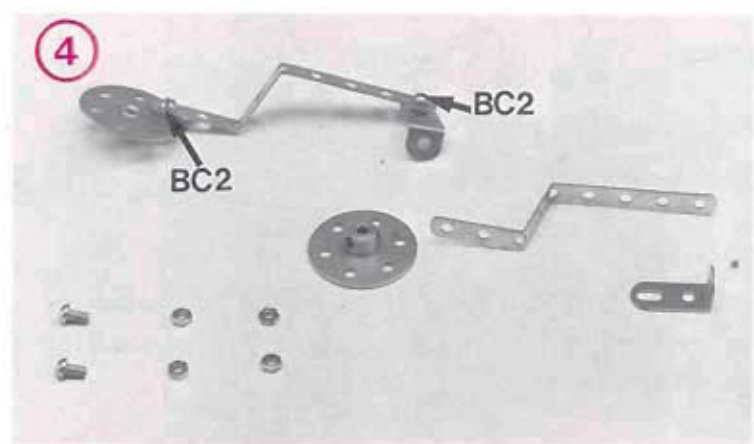
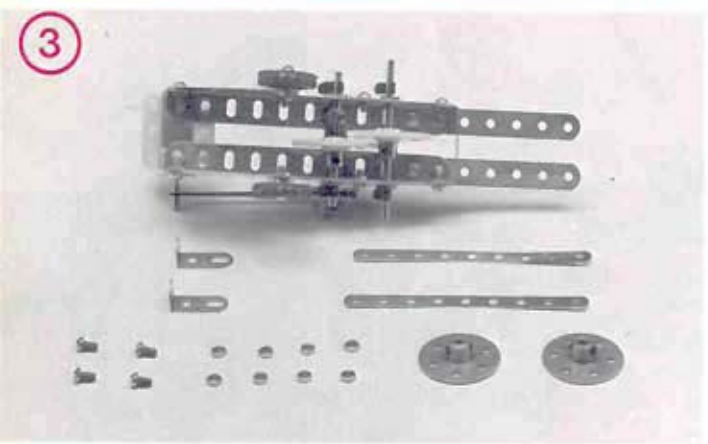
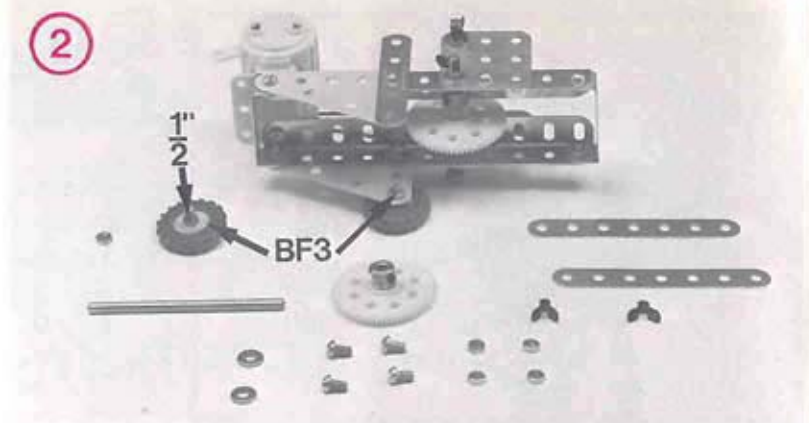
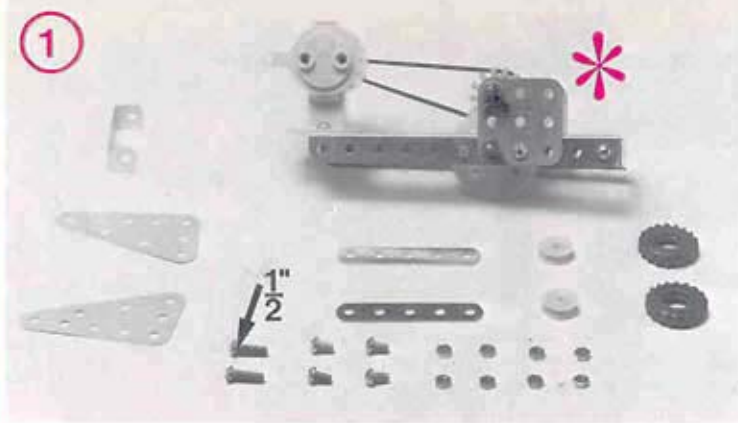

Lunar Lurcher

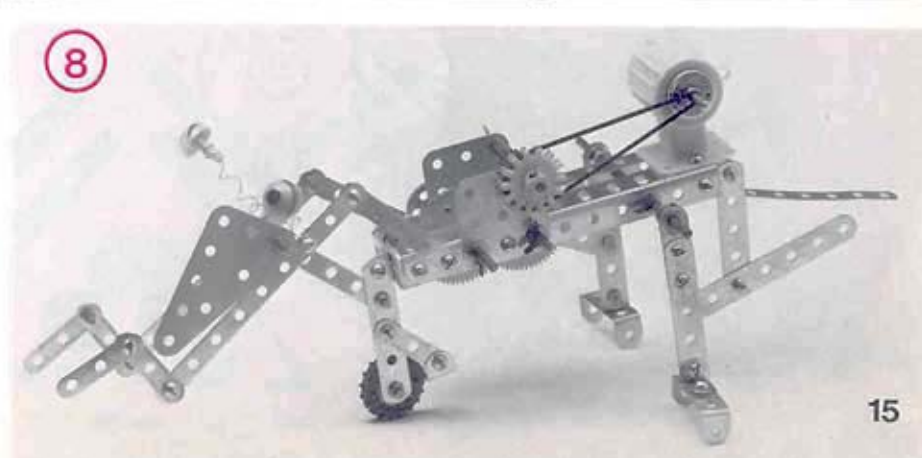
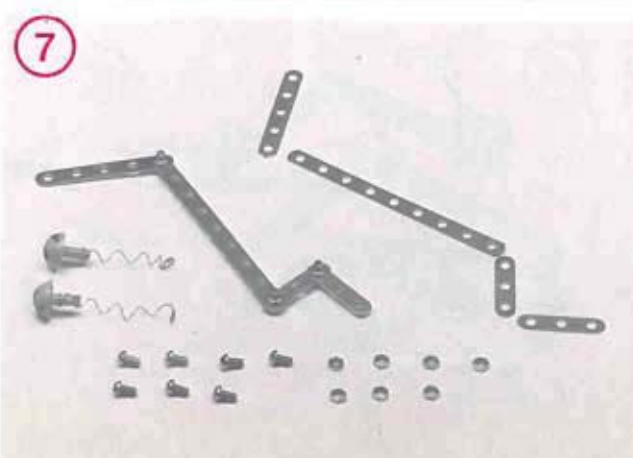
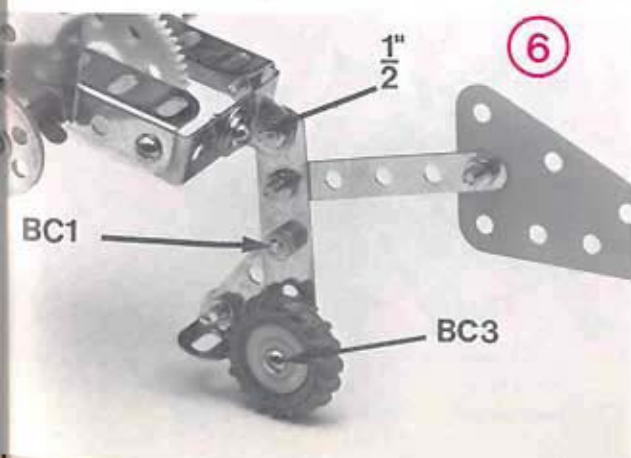
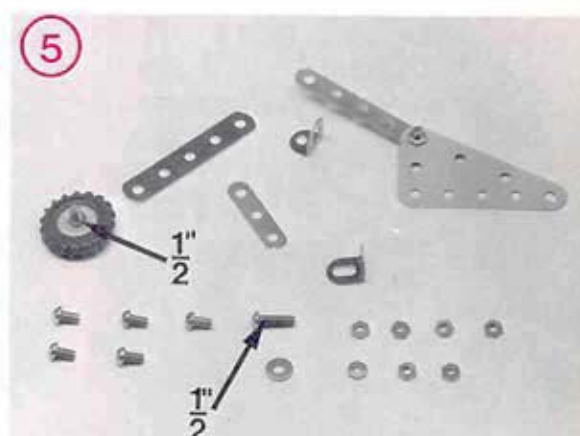
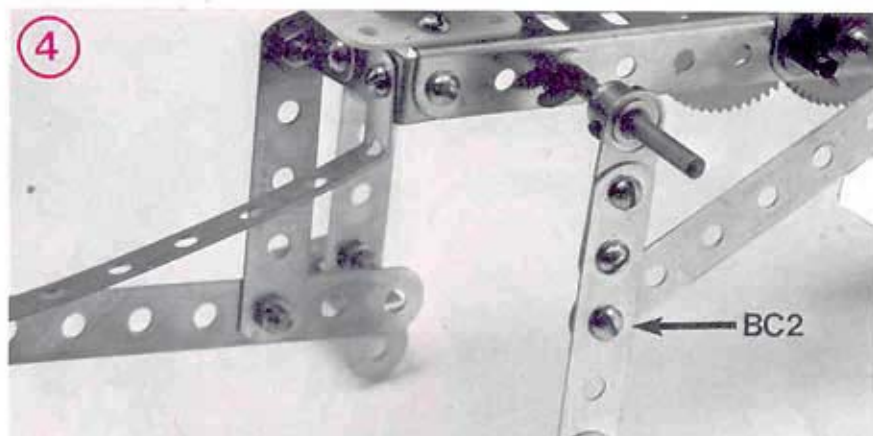
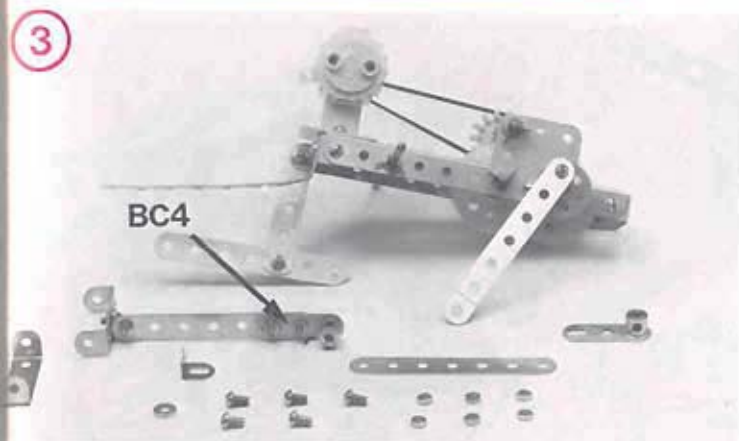
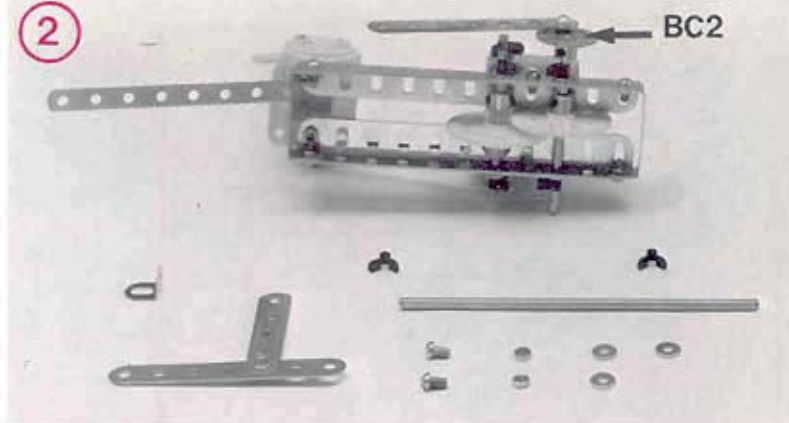
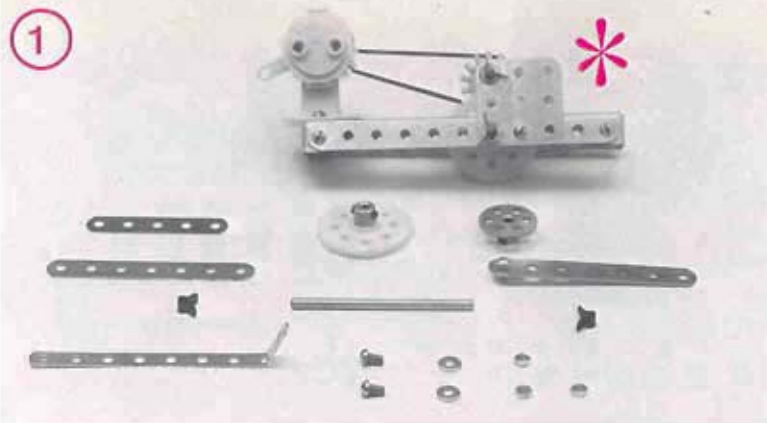

Mercurian Creeper

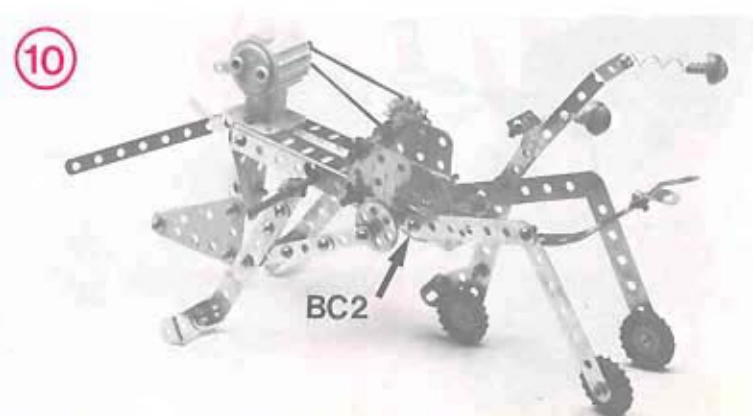
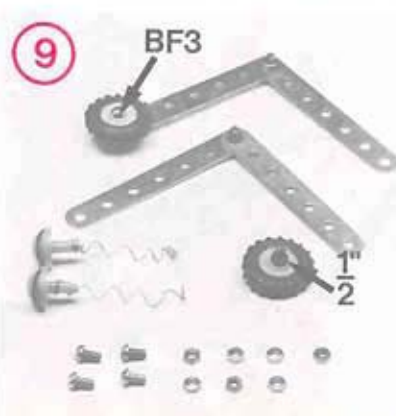
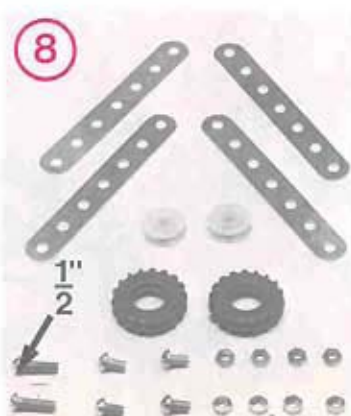
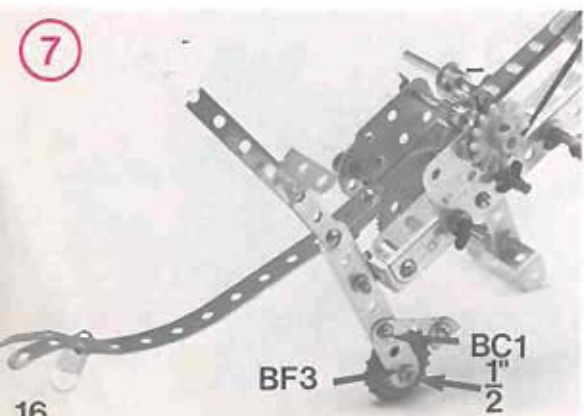
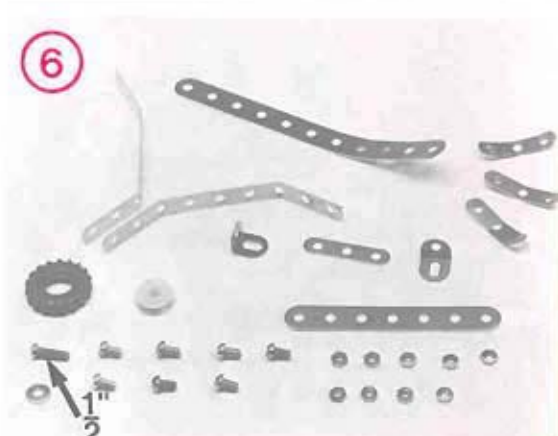
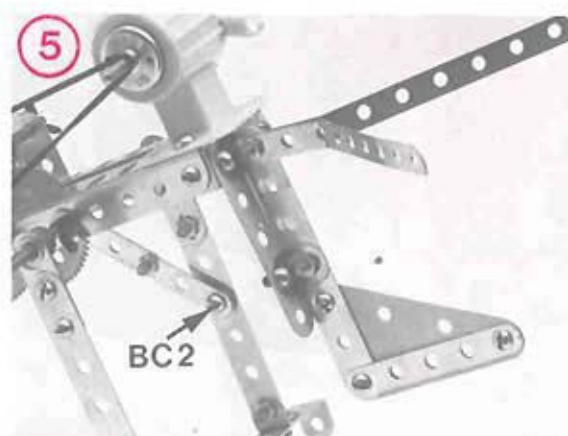
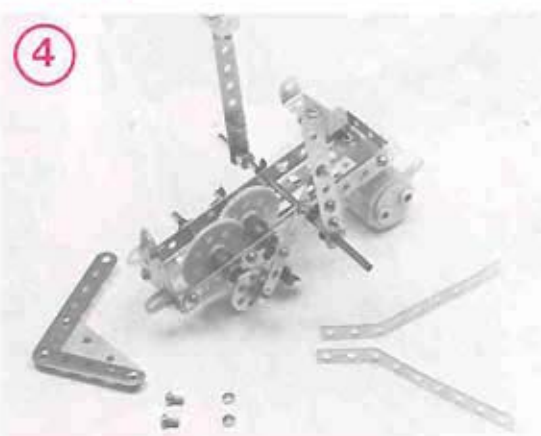
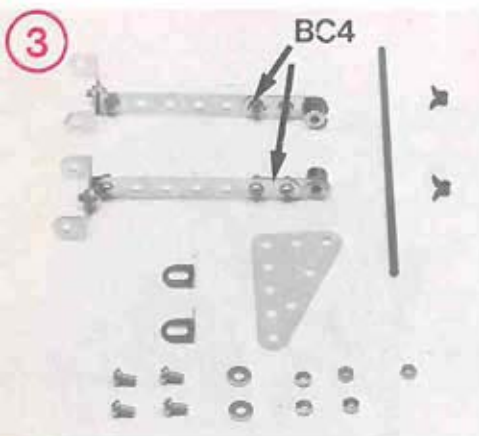
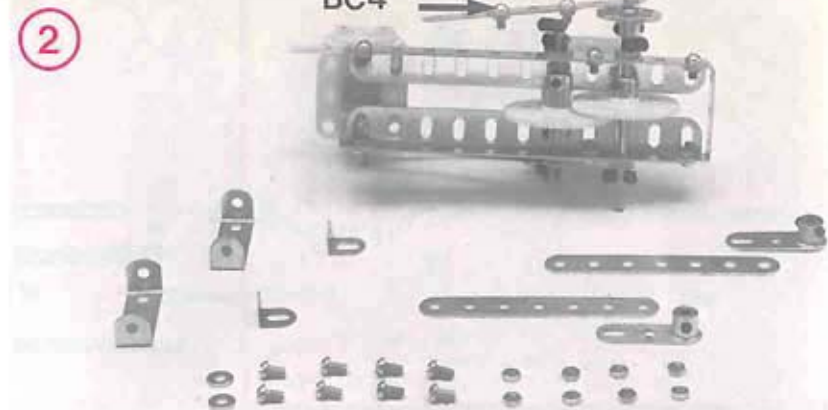
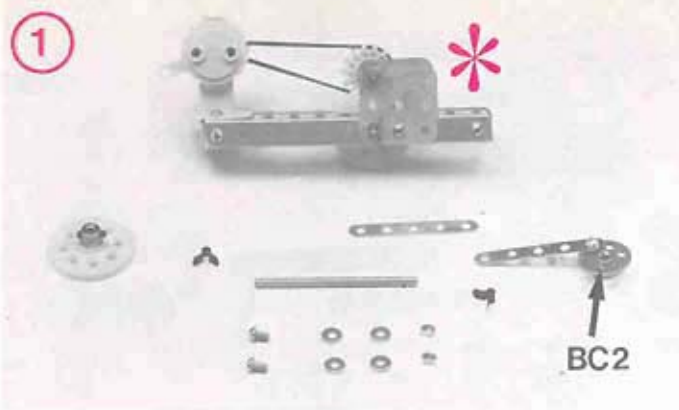

Uranian Rhino

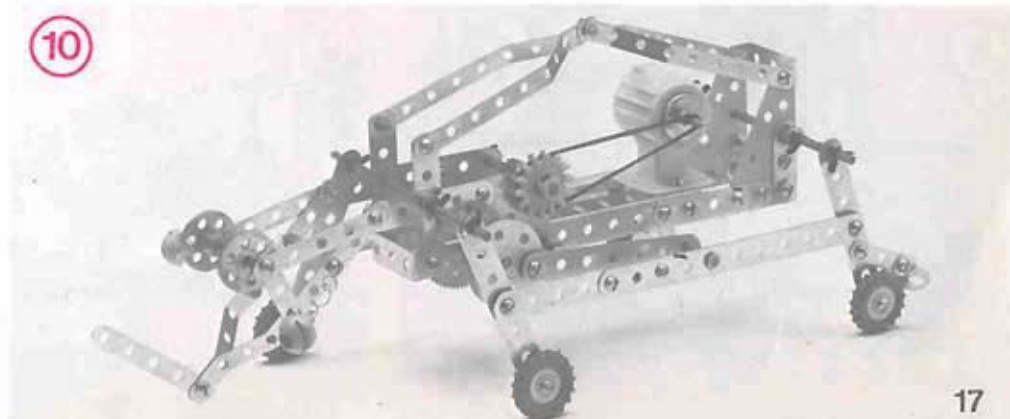
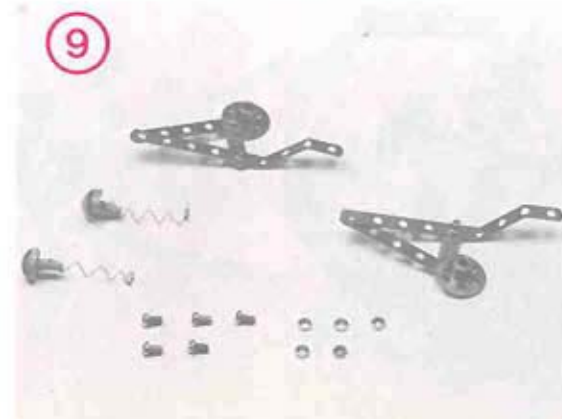
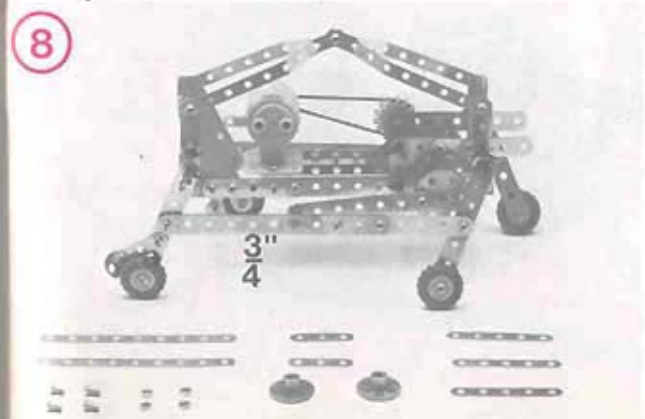
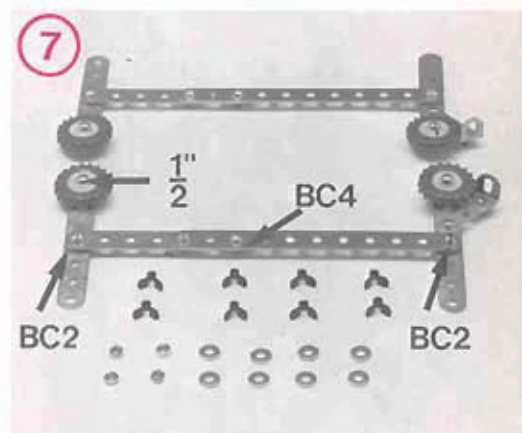
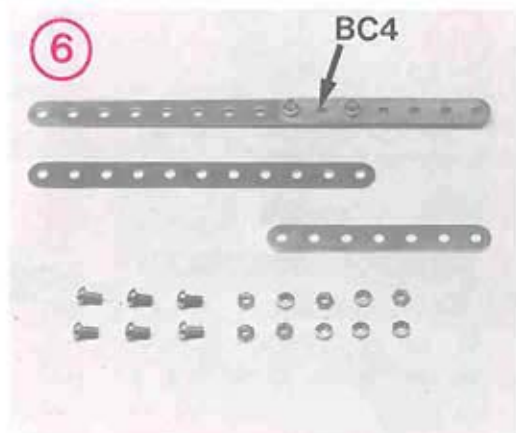
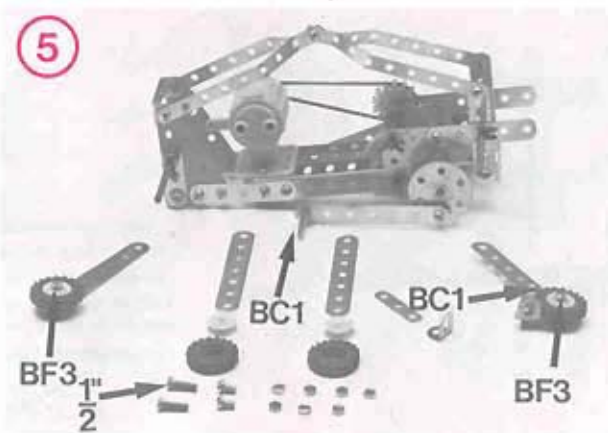
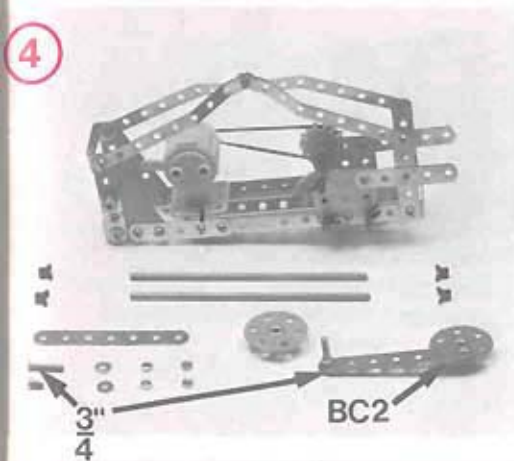
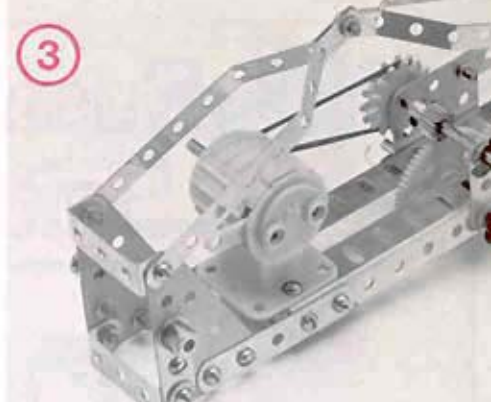
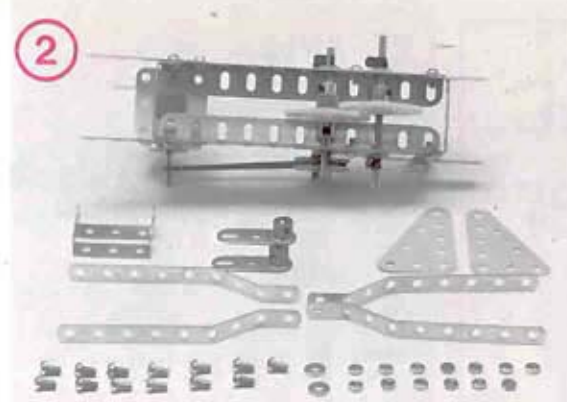
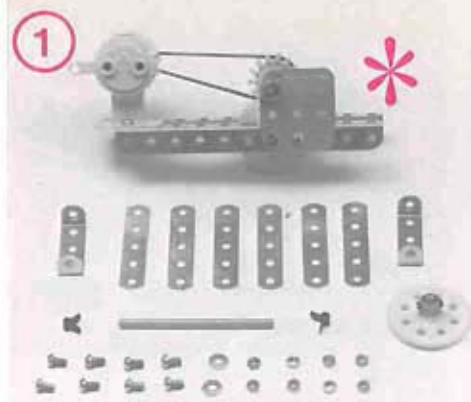

Cosmic Spider

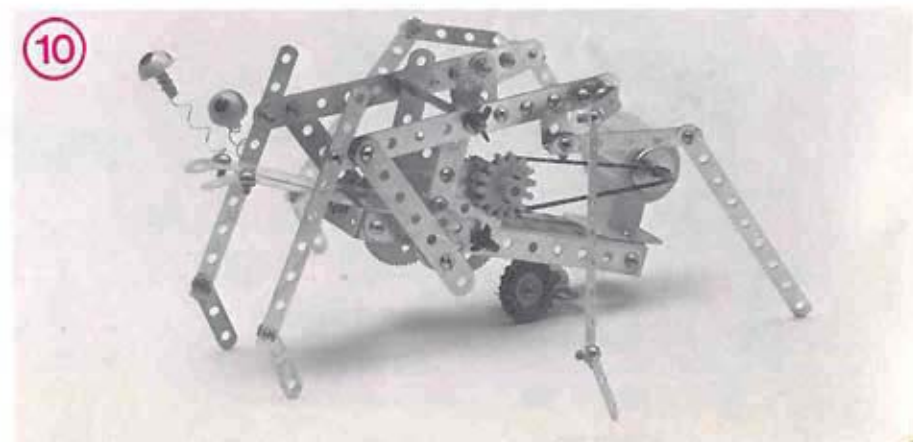
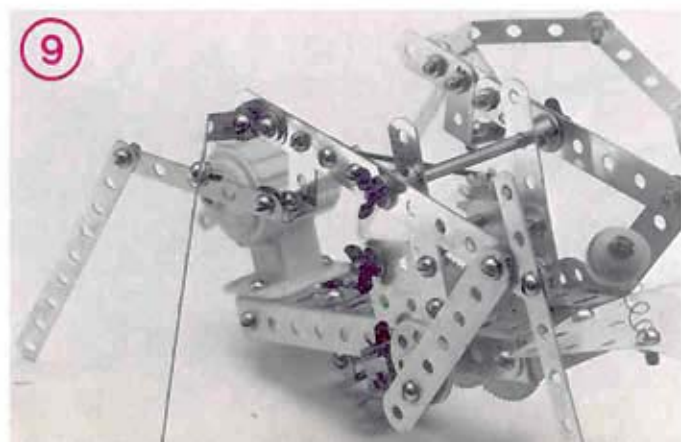
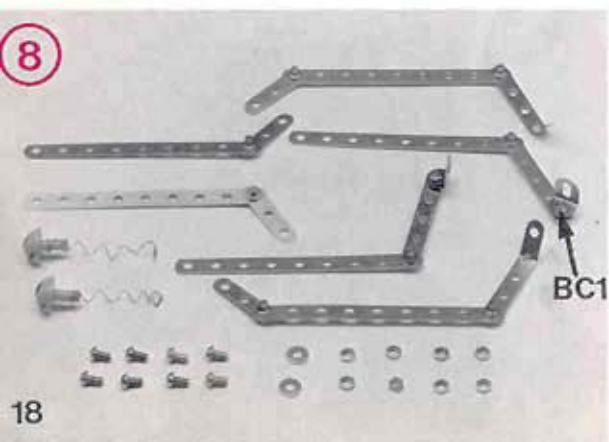
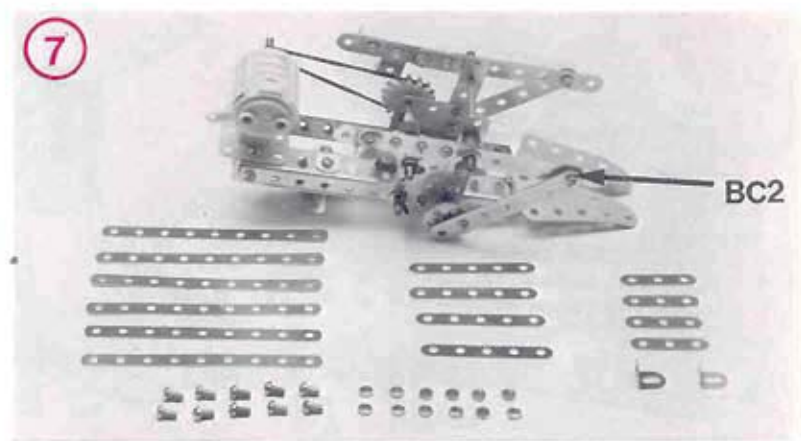
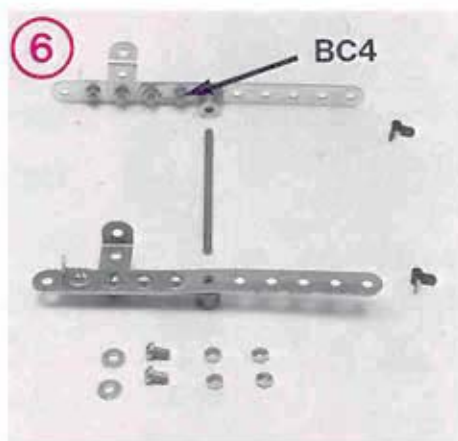
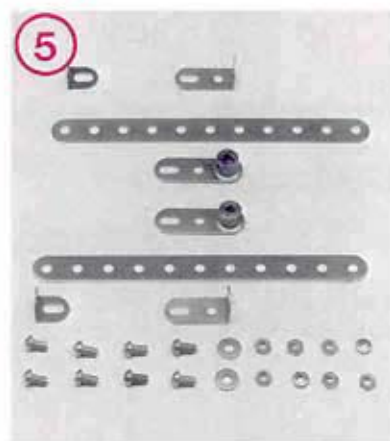
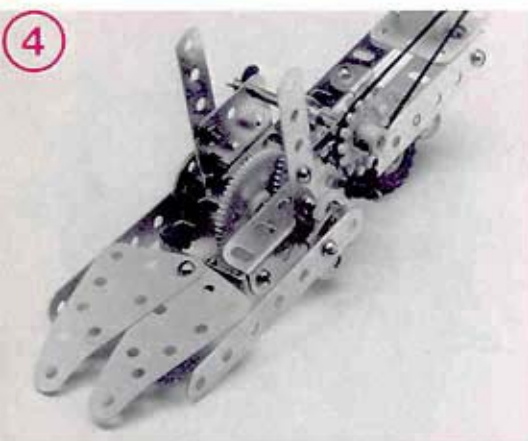
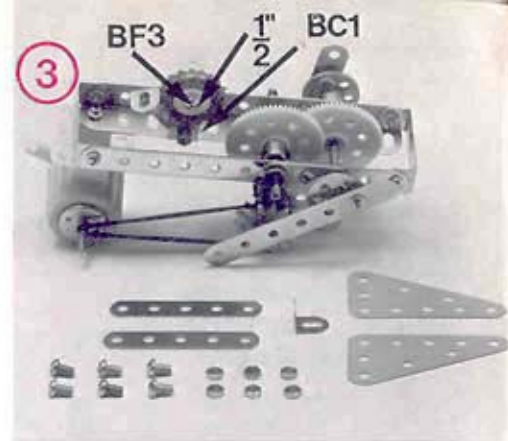
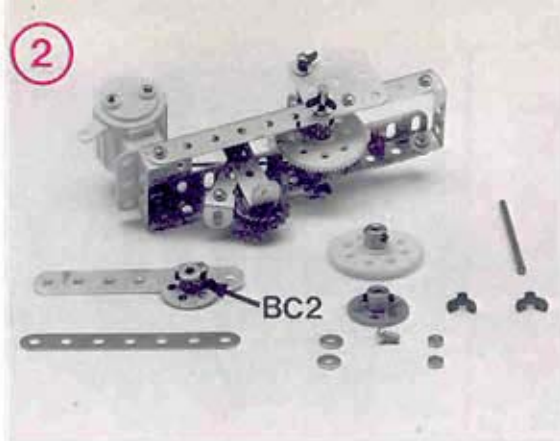
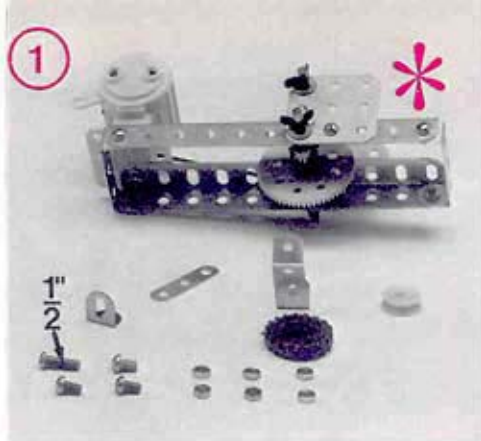

Cyborg Robot

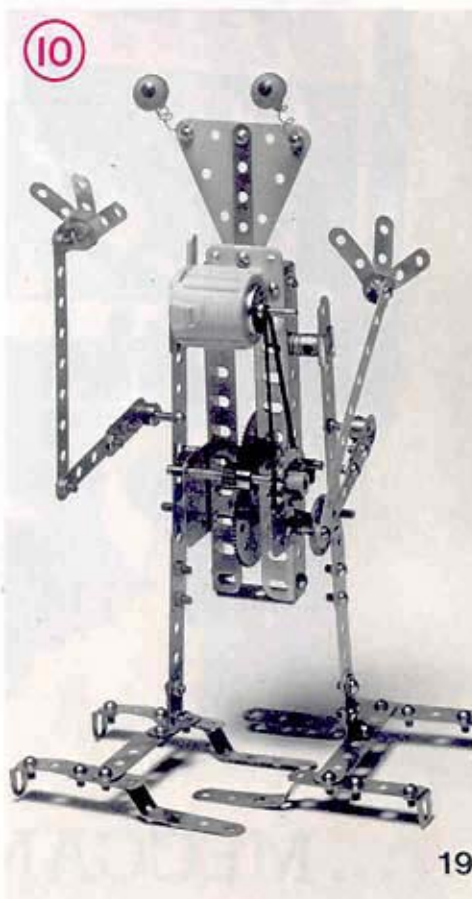
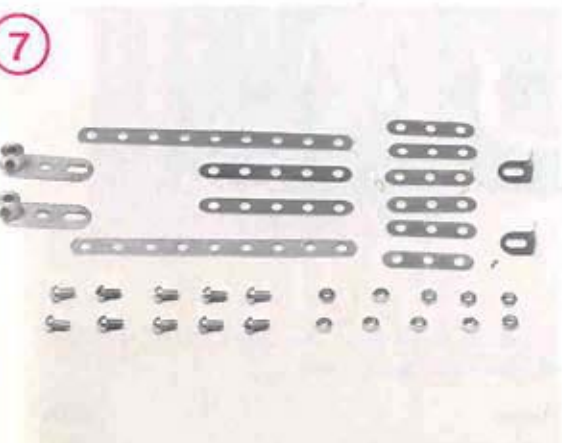
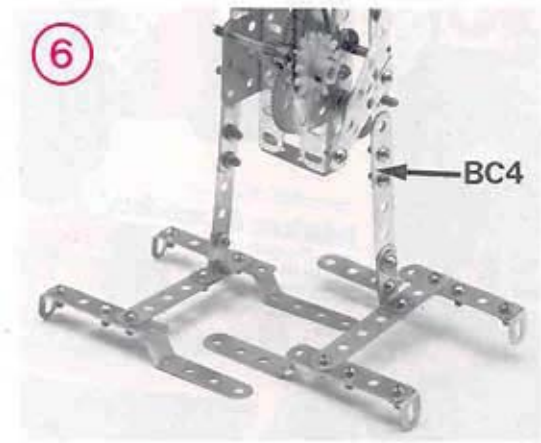
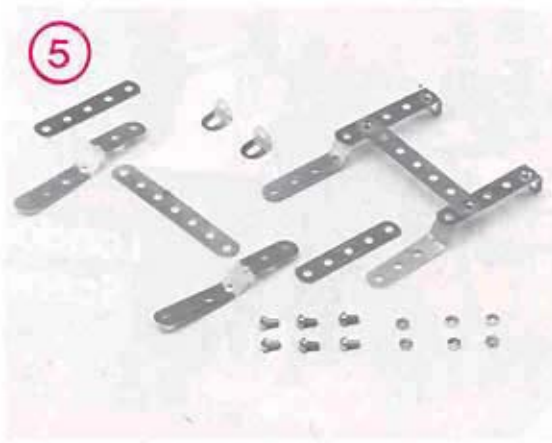
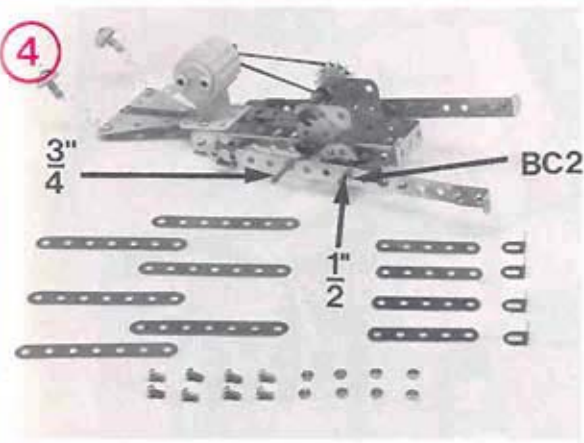
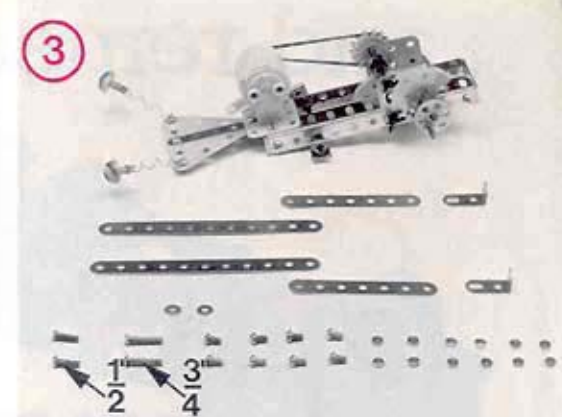
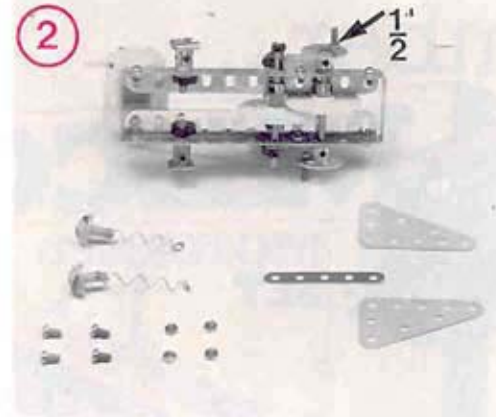
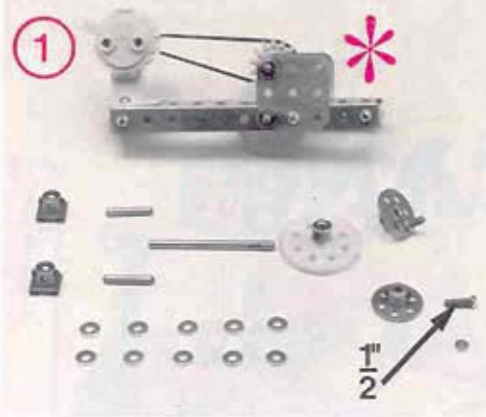

..and remember...



... MECCANO means a whole world of fun!

© 1979 Meccano Ltd, Binns Road, Liverpool L13 1DA, England.

MADE BY **MECCANO** ENGLAND



Printed in England

162174