

The floor of the wagon consists of two 5 1/2" x 2 1/2" Flexible Plates 8 and two 5 1/2" x 2 1/2" Flexible Plates 9. The front ends of the two 5 1/2" x 2 1/2" Flexible Plates 9 are bent up slightly and form the driver's footboard. The floor is attached to the sides of the wagon by the 2 1/2" x 1 1/2" Double Angle Strips 10 and 12 and the Angle Brackets 11 and 13. The front members are bolted to two Rods 4 and Strip Connectors 16 pushed on the ends of 2 1/2" Rods passed through holes in the sides of the bonnet.

The bonnet is constructed from two 5 1/2" x 2 1/2" Flexible Plates bent at right-angles at the centre. The Plates are connected at the rear by two 1 1/2" Strips 11 and 12. Strips 11 and 12 are bolted to the flange of a 2 1/2" x 1 1/2" Flanged Plate that forms the radiator. The sides of the radiator are bolted to two Angle Brackets fastened to the Semi-Circular Plates 5. The Semi-Circular Plates are fixed to a 2 1/2" x 1 1/2" Double Angle Strip bolted between the 12" Strips 11 in their front ends. A 5 1/2" Strip 6 is bolted to two Trunnions fixed to the 12" Strips 11. Flat Girders are bolted to each side of Strip 6 immediately behind the Semi-Circular Plates 5. Two 2 1/2" Flat Girders are bolted each side of Strip 6 and joined across at the top by two 2 1/2" Strips 7, which overlap each other by one hole. A 5 1/2" Strip forms the dash.

Two 12 1/2" Strips 1 overlapping the flanges of the 5 1/2" x 2 1/2" Flanged Plate 2 nine holes, form the sides of the chassis. From the front end, A 4 1/2" Rod 4 is passed through holes in the Flat Girders and 12" Strips 1 and fitted with two Spring Clips. The Rod holds the rear ends of the Flat Girders in position.

These side members are also strengthened by two 5 1/2" x 2 1/2" Flanged Plate 2 nine holes, bolted to the 12" Strips 1 seven holes with two 1 1/2" Strips 11 overlapping the flanges of the 5 1/2" x 2 1/2" Flanged Plate 2 nine holes, form the sides of the chassis, and it is on one of these that the model shown above is based.

Wide and reliable means of transport are essential to a modern army and most requirements now-a-days are equipped with powerful weapons so that detachments of men and horses can be transported from place to place as rapidly as possible. Some of the wagons are fitted with creeper tracks to allow them to travel over rough country.

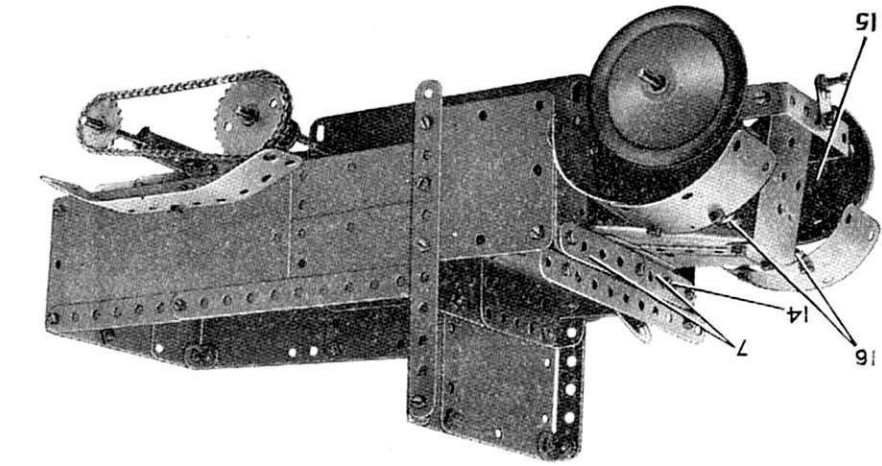

The rear axles are 6 1/2" Rods mounted in the end holes of two compound strips made from Curved Strips and 2 1/2" Strips. The compound strips are pivotally attached to the chassis by 1 1/2" Bolts that carry Washers on their shanks for spacing purposes. The axles carry 1 1/2" and 1" Sprocket Wheels that form the drivers for the creeper tracks, which consist of endless lengths of Sprocket Chain.

Two 1 1/2" Discs, one of which can be seen at 15 are held against the bosses of the front Road Wheels by Spring Clips and represent brake drums.

The rear axles are 6 1/2" Rods mounted in the end holes of two compound strips made from Curved Strips and 2 1/2" Strips. The compound strips are pivotally attached to the chassis by 1 1/2" Bolts that carry Washers on their shanks for spacing purposes. The axles carry 1 1/2" and 1" Sprocket Wheels that form the drivers for the creeper tracks, which consist of endless lengths of Sprocket Chain.

MODEL No. 6. TRANSPORT WAGON

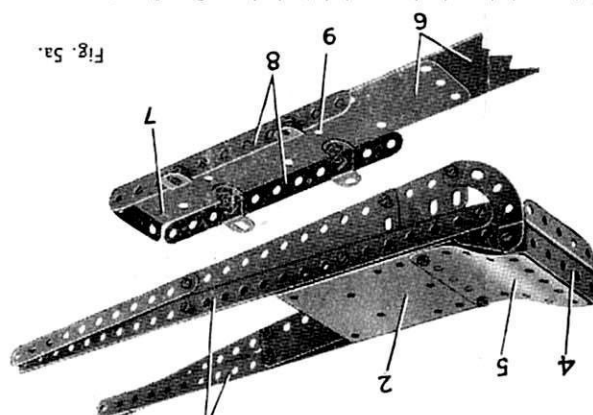

The gun barrel is built up from Large and Medium Gun Barrels, and is bolted to the Flexible Plates 6 by a 1 1/2" Bolt. The sides of the cradle are completed with two 5 1/2" Strips 8. The gun barrel is bolted in position on the trailer by a 1 1/2" Bolt. The 2 1/2" x 1 1/2" Flanged Plate 12 has two 2 1/2" x 1 1/2" Double Angle Strips bolted between its flanges, and the complete Flexible Plates and one 5 1/2" x 1 1/2" Flexible Plate form the top. Two 5 1/2" Flat Girders 11, two 3 1/2" x 2 1/2" x 2 1/2" Strips, plates being strengthened at their lower edges by 5 1/2" Strips. The sides of the cradle are completed at the front by 2 1/2" x 1 1/2" Flexible Plates joined together at the corners by Angle Brackets, the front and rear forms the breech and is also held by the 1 1/2" Bolt.

Two 1 1/2" radius Curved Plate 10 is connected at the rear hole 9. The 1 1/2" radius Curved Plate 10 Bolt passed through the rear hole in the Large Gun Barrel and through hole 9. The 1 1/2" radius Curved Plate 10 is connected at the rear hole 9. The 1 1/2" radius Curved Plate 10 Bolt passed through the rear hole in the Large Gun Barrel and through hole 9.

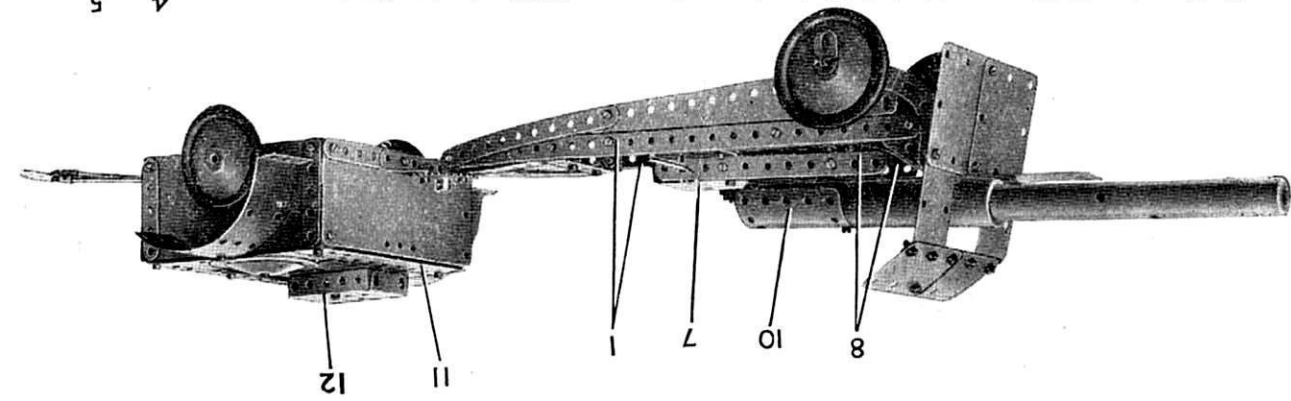

MODEL No. 5. 18-POUNDER QUICK-FIRING FIELD GUN AND TRAILER

MECCANO MECHANISED ARMY OUTFIT PARTS AND CONTENTS OF OUTFIT

No.	Description	Quantity in Outfit	No.	Description	Quantity in Outfit
M1	12 1/2" Perforated Strips	2	M95a	Sprocket Wheels, 28 teeth, 1 1/2" dia.	2
M2	5 1/2" " "	6	M96	Sprocket Wheels, 18 teeth, 1" dia.	2
M3	3 1/2" " "	2	M103	Flat Girders 5 1/2"	4
M5	2 1/2" " "	7	M103f	" "	2
M9a	1 1/2" " "	2	M111	Bolts, 1 1/2" long	3
M10	Flat Brackets	2	M111c	Bolts, 1 1/2" long	1
M12	Angle Brackets, 2 1/2" x 1 1/2"	12	M111d	Bolts, 1 1/2" long	1
M14	6 1/2" Axle Rods	3	M125	Reversed Angle Brackets, 1 1/2"	2
M15a	4 1/2" " "	2	M126	Trunnions	2
M16a	2 1/2" " "	1	M187	Road Wheels	4
M24	Bush Wheels	2	M188	Flexible Plates 2 1/2" x 1 1/2"	6
M34	Spanners	2	M189	" " 5 1/2" x 1 1/2"	4
M35	Spring Clips	10	M190	" " 2 1/2" x 2 1/2"	2
M36	Screwdrivers	1	M190a	" " 3 1/2" x 2 1/2"	2
M37	Nuts and Bolts, 7/32"	82	M192	" " 5 1/2" x 2 1/2"	4
M37a	Nuts	74	M200	Curved Plates, 1 1/2" radius	2
M37b	Bolts, 7/32"	10	M212	Rod and Strip Connectors	2
M38	Washers	10	M214	Semi-Circular Plates, 2 1/2"	2
M48a	Double Angle Strips, 2 1/2" x 1 1/2"	4	M217a	Discs, 1 1/2"	2
M51	Perforated Flanged Plates, 2 1/2" x 1 1/2"	1	M219	Wheel Discs	1
M52	Perforated Flanged Plates, 5 1/2" x 2 1/2"	1	M220a	Gun Barrel, Large	1
M90a	2 1/2" Curved Strips, Cranked, 1 1/2" radius, 4 to circle	2	M220b	" " Medium	1
M94	Sprocket Chain	1	M220c	" " Small	1

"MECCANO MAGAZINE"

The "Meccano Magazine" is the ideal paper for all boys who take a keen interest in the world around them. Month by month its pages are filled with attractively written articles splendidly illustrated from actual photographs.

All kinds of interesting subjects are dealt with, including Railways, Aeroplanes, Motor Cars, Ships, Wonderful Machinery, Inventions and Discoveries.

Special sections are devoted to Meccano, with Model-building Competitions for Outfits of all sizes. There are also Competitions for owners of Hornby Trains, and fascinating articles showing how to get the best possible fun from a miniature railway.

Stamp Collecting forms an important feature, and there are practical articles on Photography, and reviews of new Books of interest to boys.

The "Meccano Magazine" is on sale at all bookstalls, newsagents or Meccano dealers on the first of each month, price 6d. If you prefer to have each issue sent direct, the subscription rates are 8/- for twelve months, or 4/- for six months, including postage.

THE WORLD'S BEST MAGAZINE FOR BOYS



PUBLISHED MONTHLY PRICE 6d.



MECCANO

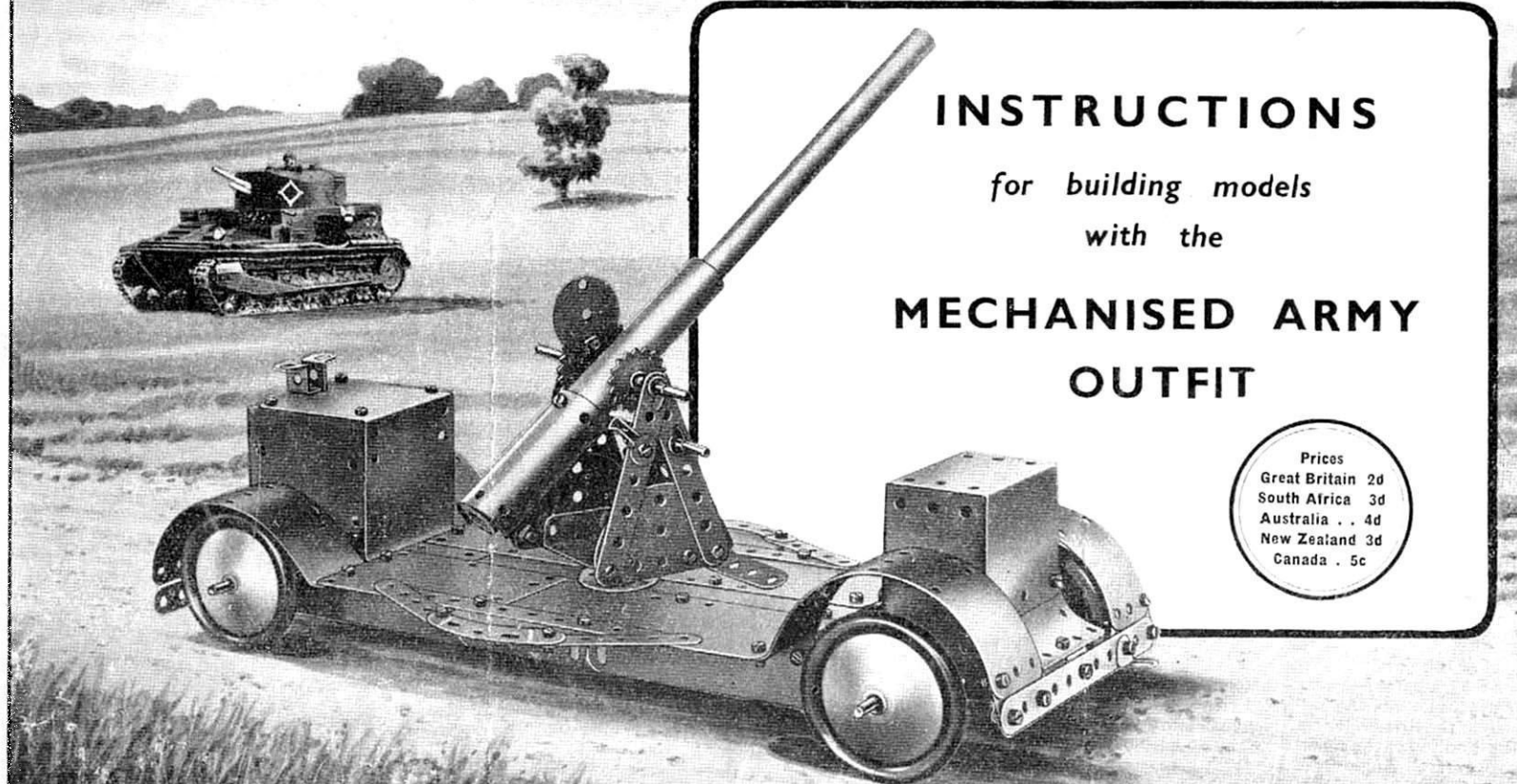

INSTRUCTIONS for building models with the MECHANISED ARMY OUTFIT

Prices Great Britain 2d South Africa 3d Australia . . . 4d New Zealand 3d Canada . 5c

MODEL No. 1. MOBILE ANTI-AIRCRAFT GUN

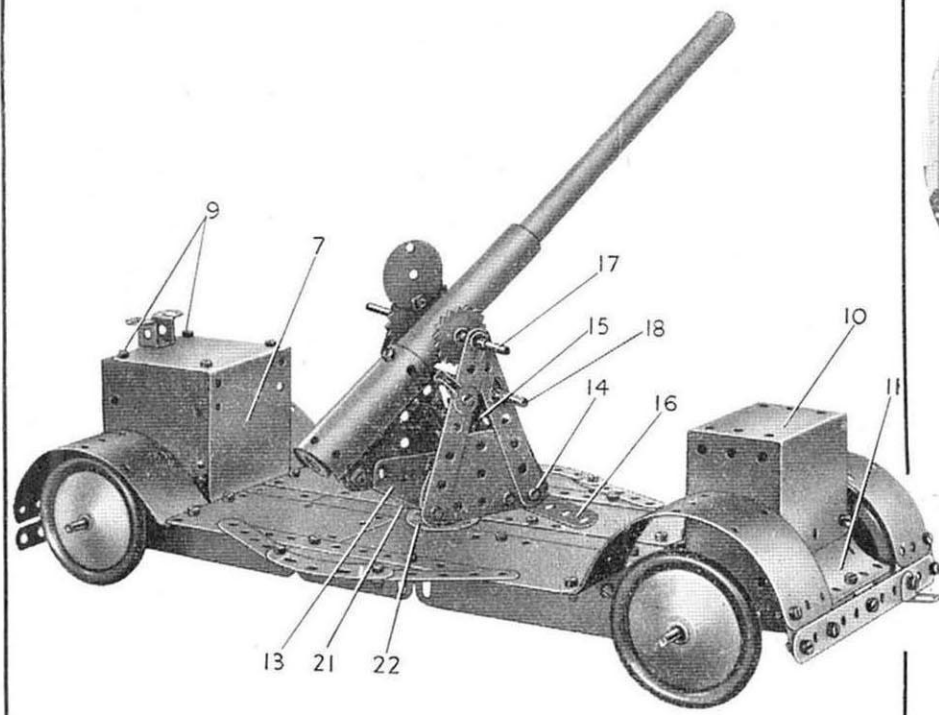

This fine model is based on one of the 3.7 in. mobile anti-aircraft guns that form a part of Britain's air-raid defences, and it has a very attractive and workmanlike appearance. The gun has a full range of movement and can be elevated and swivelled in any direction.

Construction of the model should be commenced by assembling the chassis of the mobile platform on which the gun is mounted. This consists of two 12 1/2" Strips 1 (Fig. 1a) connected at one end to 5 1/2" Flat Girders, which overlap the Strips five holes so as to give a total length of 15 1/2". These side members are then joined together by a 5 1/2" x 2 1/2" Flanged Plate 2. The portion of the platform on which the gun is mounted is constructed from two 5 1/2" x 2 1/2" Flexible Plates 3 and two 3 1/2" x 2 1/2" Flexible Plates 4, the remainder being completed by 2 1/2" x 11" Flexible Plates 5 and 6.

A 5 1/2" x 2 1/2" Flexible Plate 7 is bent one way at right-angles 1/2" from one end and the opposite way 2 1/2" from its other end, and is used to form the top and back of the shell locker. Two 2 1/2" x 2 1/2" Flexible Plates 8 (Fig. 1a) are then bolted together to form a 4 1/2" x 2 1/2" plate, which is then bent one way at right-angles 1/2" from one end and the opposite way 1" from the other end and is bolted to Plate 7 by Bolts 9. The sides of the locker are 2 1/2" x 2 1/2" Flexible Plates bent at right-angles 1/2" from the top, and fixed by Bolts in the positions shown.

The other locker is made up of a 5 1/2" x 2 1/2" Flexible Plate 10 bent as shown and attached to the chassis by a 1 1/2" radius Curved Plate 11 and a 2 1/2" x 1 1/2" Flexible Plate. The latter is bolted to the 2 1/2" x 1 1/2" Double Angle Strip 12. Each side is filled in with a 2 1/2" x 2 1/2" Flexible Plate, the edges of which are bent at right-angles.

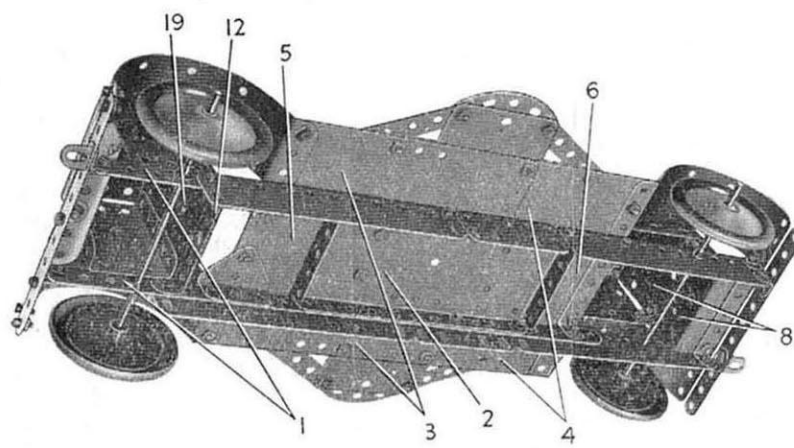
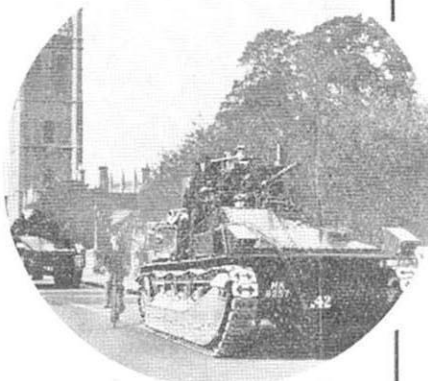

Fig. 1a.

The sides of the gun mounting are similar in construction. They are connected together by a 2 1/2" x 1 1/2" Flanged Plate 13. A 2 1/2" x 1 1/2" Double Angle Strip held by Bolts 14 carries also the 2 1/2" x 1 1/2" Flexible Plate 15. The 5 1/2" Strip 16 representing the foot-rest is attached to this Double Angle Strip by an Angle Bracket. The gun barrel is clamped between a 1 1/2" Sprocket Wheel and a 1" Sprocket Wheel on 4 1/2" Rod 17. A second 1" Sprocket Wheel fastened on 4 1/2" Rod 18 meshes with the 1" Sprocket Wheel on Rod 17. A Rod and Strip Connector pushed on the end of Rod 18 has a 3/8" Bolt fixed to it by two Nuts, and forms a handle for elevating the gun barrel.

A Bush Wheel 21 is bolted under the Flanged Plate 13 and has a 2 1/2" Rod locked in its boss. The Rod is passed through the centre hole of the 1 1/2" Disc 22, and then through the centre hole of the 5 1/2" x 2 1/2" Flanged Plate 2. A 1 1/2" Sprocket Wheel is then locked on the Rod under the Flanged Plate and retains the gun in position. A Wheel Disc is bolted to the small locker by Bolt 19 to represent the spare wheel cover. Two Reversed Angle Brackets form a cradle on which the gun barrel rests when travelling.

How to Build Models with the Mechanised Army Outfit General Instructions



Army Tank of the Medium type.

In building model guns the Gun Barrels must always be assembled in position with their bored ends pointing forward. Guns of various types can be represented by using the Large, Medium and Small Gun Barrels singly or in suitable combinations. A Large Gun Barrel can be joined to a Medium Gun Barrel by pushing the end of the Medium section into the bored end of the Large section. Large, Medium and Small Gun Barrels can be joined in a similar manner. In models such as the Mobile Anti-Aircraft Gun (Model No. 1) and Searchlight Lorry (Model No. 3), it is necessary to bend Flexible Plates to form curved mudguards. The best way to do this is to bend the Plates around a cylindrical article of slightly smaller diameter than the curve required. When Flexible Plates have to be bent at right angles, as in making the bonnet of the Transport Wagon (Model No. 6), a Strip should be held by the fingers on each side of the Plate, along the line where the bend is required. The Plate can then be bent quite easily, and a neat, straight edge will result.

In some models it is necessary to join certain parts together so that, although they cannot come apart, they are free to pivot or move in relation to one another. To do this a bolt is passed through one part and a Nut is placed on it but is not screwed up tightly, so that the part is not gripped. The second part is then placed on the Bolt and secured rigidly against the first Nut by a second Nut. In this way one of the parts is free to move without affecting the other part.

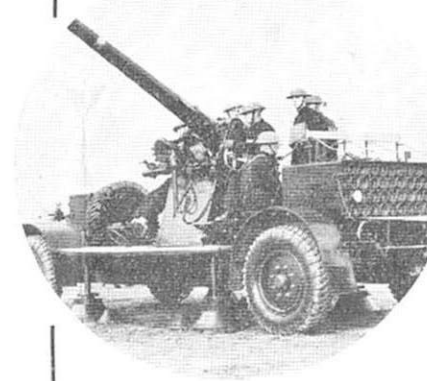

Mobile Anti-Aircraft Gun and crew.

MODEL No. 2. LIGHT TANK

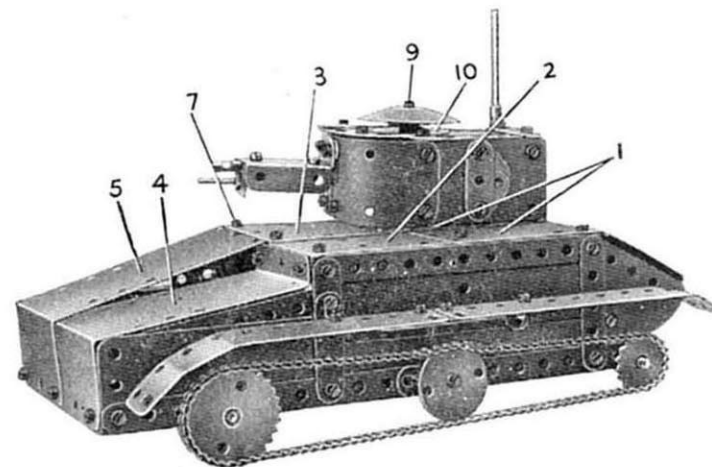

This realistic model of a modern tank is fitted with a machine gun in front of the turret, which swivels completely round, and its general outline is based on the light tanks used in the Royal Tank Corps.

The construction of the model is commenced by overlapping two 5 1/2" x 2 1/2" Flexible Plates 1 1/2" along their length and bending them to an angle of 150 deg. at a distance 2 1/2" from one end. They are bent again 1/2" from the same end and are extended forward by 5 1/2" Flanged Plate 2 and 2 1/2" x 2 1/2" Flexible Plate 3. Each side is filled in with three 5 1/2" x 1 1/2" Flexible Plates and is strengthened by 5 1/2" and 2 1/2" Strips in the manner shown. Semi-Circular Plates complete the rear part of the sides.

Two 5 1/2" x 2 1/2" Flexible Plates 4 and 5 are each bent as shown. Plate 4 is bolted at one end to a flange of the Flanged Plate 2, and at the other end to the 2 1/2" x 1 1/2" Double Angle Strip 6 (Fig. 2b). Plate 5 overlaps Plate 4 1/2" on its long edge, and is bolted at the bottom end to Double Angle Strip 6 and an Angle Bracket, the other end of Plate 5 is clamped between the 2 1/2" x 2 1/2" Flexible Plate 3, and the Flanged Plate 2 at one corner and the Angle Bracket held by Bolt 7 at the other corner.

The rear underside of the tank is constructed by bolting two 1 1/2" radius Curved Plates to the end of the Flexible Plates 1. The other ends of the Curved Plates are fixed by Bolts 8 to two Angle Brackets attached to the sides.

The guards over the creeper tracks are made from 5 1/2" Flat Girders joined together by 2 1/2" Flat Girders. They are bent in the manner shown and attached to the sides of the tank by Angle Brackets.

The turret consists of a 2 1/2" x 1 1/2" Flanged Plate to the flanges of which are attached five 2 1/2" x 1 1/2" Flexible Plates to form the front and sides. The top of the turret is formed by two 2 1/2" x 2 1/2" Flexible Plates overlapped 1 1/2" and edged with three 2 1/2" Strips and two 2 1/2" Curved Strips.

A look-out man-hole is formed by a Wheel Disc locked against the head of a 1/2" Bolt 9 by a Nut. The shank of Bolt 9 is then secured in the boss of the Bush Wheel 10. Two Trunnions connected together by a 2 1/2" x 1 1/2" Flexible Plate bent in the manner shown, represent the gun casing. The flange of the rear Trunnion is spaced from the front of the turret by a Washer at each side.

The 1/2" Bolt 11 passes through the 2 1/2" x 1 1/2" Double Angle Strip in the turret and carries two Washers on its shank for spacing purposes. The Bolt is fixed by lock-nuts to the top of the tank so that the turret swivels freely.

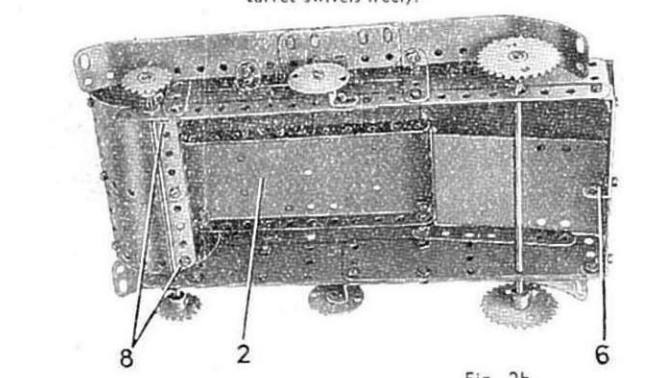
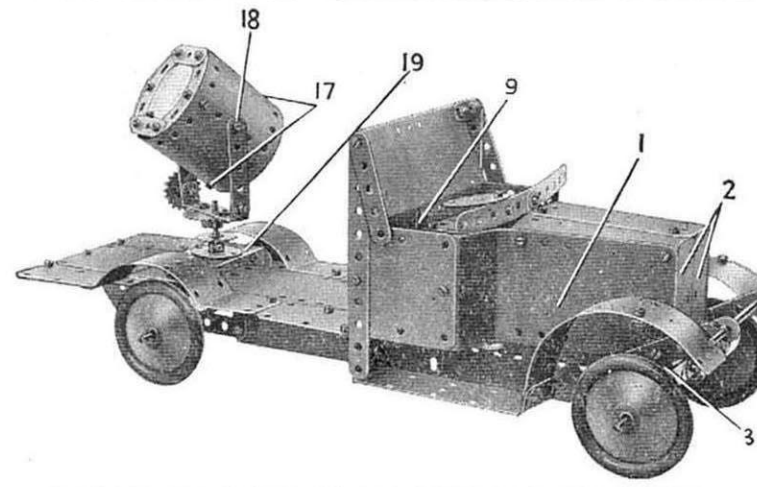

Fig. 2b.

MODEL No. 3. SEARCHLIGHT LORRY



Searchlights are used in conjunction with mobile anti-aircraft guns and are conveyed to the site in lorries.

Each side member of the chassis is constructed from two 5 1/2" Flat Girders overlapped one hole and extended to the rear by a 5 1/2" Strip. The bonnet is built up from two 5 1/2" x 2 1/2" Flexible Plates 1 bent to the shape shown, the top being filled in by two 3 1/2" x 2 1/2" Flexible Plates bent at right angles 1 1/2" from one side and bolted in place. The radiator is made from two 2 1/2" x 1 1/2" Flexible Plates 2 each bent with a 1/2" flange on one side by which it is bolted in position.

The front end of the bonnet is connected to the chassis by two Flat Brackets 3, which are bolted in the end holes of the 5 1/2" Flat Girders, by the same Bolts that hold the 2 1/2" x 1 1/2" Double Angle Strip 4 in position. Three Washers on the shank of the 1/2" Bolts 5 space the bonnet sides from the insides of the Flat Brackets 3.

A 5 1/2" x 2 1/2" Flanged Plate is bolted lengthways by the flange to the 2 1/2" x 1 1/2" Double Angle Strip 6 by Bolt 7. Bolt 7 passes through the centre hole in the end of the 5 1/2" x 2 1/2" Flexible Plate 8, then through the centre hole in the flange of the Flanged Plate and finally through the centre hole of the 2 1/2" x 1 1/2" Double Angle Strip 6. Two 2 1/2" x 2 1/2" Flexible Plates bolted between the end flanges of the 5 1/2" x 2 1/2" Flanged Plate and the ends of the 5 1/2" x 2 1/2" Flexible Plates 1 form the sides of the cab. The 5 1/2" x 2 1/2" Flanged Plate is extended upwards by a 5 1/2" x 2 1/2" Flexible Plate bent slightly as shown.

Two 2 1/2" Flat Girders overlapped one hole are attached to the back of the cab by Angle Brackets 9 to form the driver's seat.

The lorry platform is supported by two 12 1/2" Strips first bolted to the lower flange of the 5 1/2" x 2 1/2" Flanged Plate and then attached to the chassis side members by the Trunnions 10. The platform is made with a 5 1/2" x 2 1/2" Flexible Plate 8, a 3 1/2" x 2 1/2" Flexible Plate 11 and four 2 1/2" x 1 1/2" Flexible Plates 12 and 13. Two 5 1/2" x 1 1/2" Flexible Plates 14 are then bent to form mudguards. The floor is strengthened by two 3 1/2" Strips 15 and 5 1/2" Strip 16.

The searchlight body is constructed from four 1 1/2" radius Curved Plates, and the end of the cylinder thus formed is closed by two Semi-Circular Plates. The latter are bolted to a 2 1/2" x 1 1/2" Double Angle Strip which is fixed in place by Bolts 17. The 1/2" Bolt that holds the Semi-Circular Plates carries also a Wheel Disc. A piece of tin foil or celluloid may be used for the glass. The Bolts 18 are lock-nutted. The 2" Rod on which the searchlight is mounted is passed through the centre hole of the 2 1/2" x 1 1/2" Flanged Plate 19 and secured in position by the 1 1/2" Sprocket 20.

The 2 1/2" x 1 1/2" Flanged Plate 19 is fastened to the floor of the lorry by two 1/2" x 1 1/2" Angle Brackets.

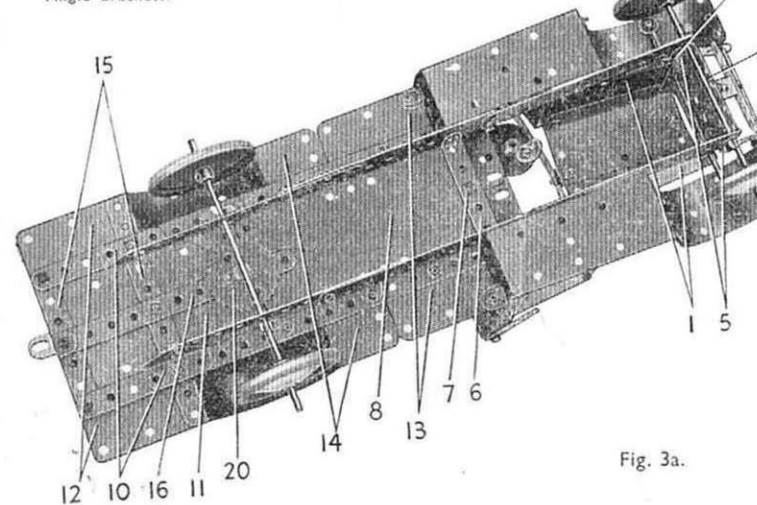
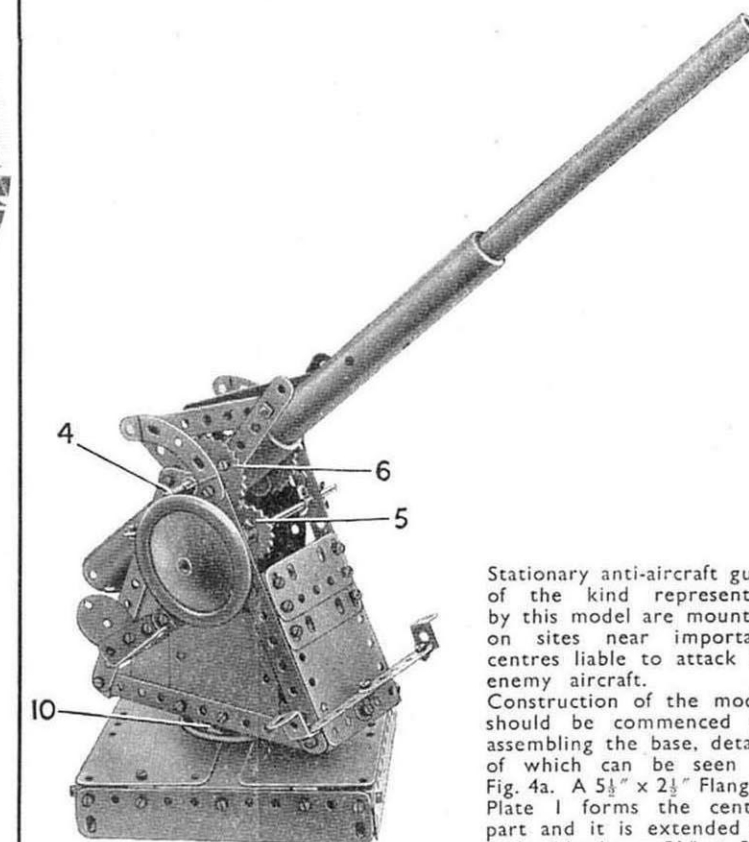

Fig. 3a.

MODEL No. 4. STATIONARY ANTI-AIRCRAFT GUN



Stationary anti-aircraft guns of the kind represented by this model are mounted on sites near important centres liable to attack by enemy aircraft.

Construction of the model should be commenced by assembling the base, details of which can be seen in Fig. 4a. A 5 1/2" x 2 1/2" Flanged Plate 1 forms the centre part and it is extended at each side by a 5 1/2" x 2 1/2" Flexible Plate. The sides are edged with 5 1/2" Flat Girders.

The sides of the gun mounting are similar in construction. They consist of triangular frames each made from three 5 1/2" Strips, two of which are connected as shown by a 1 1/2" Strip. These frames are filled in with two 2 1/2" x 2 1/2" Flexible Plates and one 2 1/2" x 1 1/2" Flexible Plate. Seats for the gun crew are mounted on each of the sides and they consist of a Trunnion fitted with a 1 1/2" Disc. The seats are attached to the sides by Angle Brackets and Flat Brackets. The two sides are joined together by the 2 1/2" x 1 1/2" Flanged Plate 2 and Double Angle Strips 3, parts of the latter type also being used to connect their lower corners. The front of the mounting is filled in with a 2 1/2" x 2 1/2" Flexible Plate and two 2 1/2" Flat Girders. A 4 1/2" compound strip made from two 2 1/2" Strips, is fitted at each end with a Reversed Angle Bracket and is attached to the front of the gun mounting by an Angle Bracket. It forms a foot rest for the gun crew.

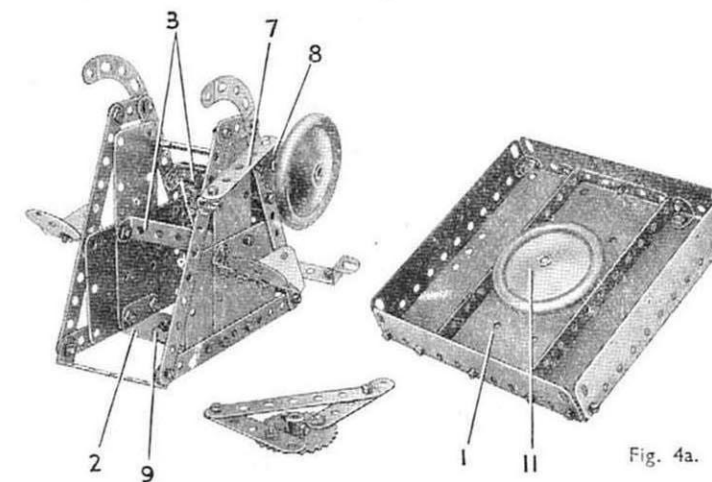

Fig. 4a.

The gun barrel consists of Large, Medium and Small Gun Barrels joined together, and is mounted between two triangular frames on the 4 1/2" Rod 4, one frame being shown in Fig. 4a. The 3/8" Bolts, which fix 2 1/2" Strips to the 1 1/2" Sprocket Wheels, press against the assembled gun barrel and hold it firmly on the Rod. A 1" Sprocket Wheel 5 is locked on a second 4 1/2" Rod and is arranged to mesh with the 1 1/2" Sprocket Wheel 6. Elevation of the gun is controlled by a Road Wheel secured on the lower 4 1/2" Rod.

A 2 1/2" Strip 7 is attached by an Angle Bracket to the side of the gun mounting, in such a manner that the hole at the end of the Strip engages the teeth of 1" Sprocket Wheel 8 and prevents the Rod on which this is mounted from turning. The gun barrel is thus held at any angle desired.

A 2" Rod is locked in the boss of a Bush Wheel 9 bolted in the centre of Flanged Plate 2, and is passed through the boss of Road Wheel 10, through the centre hole of Flanged Plate 1 and finally a Road Wheel 11 is fixed on the Rod beneath the base. This arrangement ensures that the gun can be slewed in a complete circle.