

# MECCANO

1928

# BOOK OF NEW MODELS

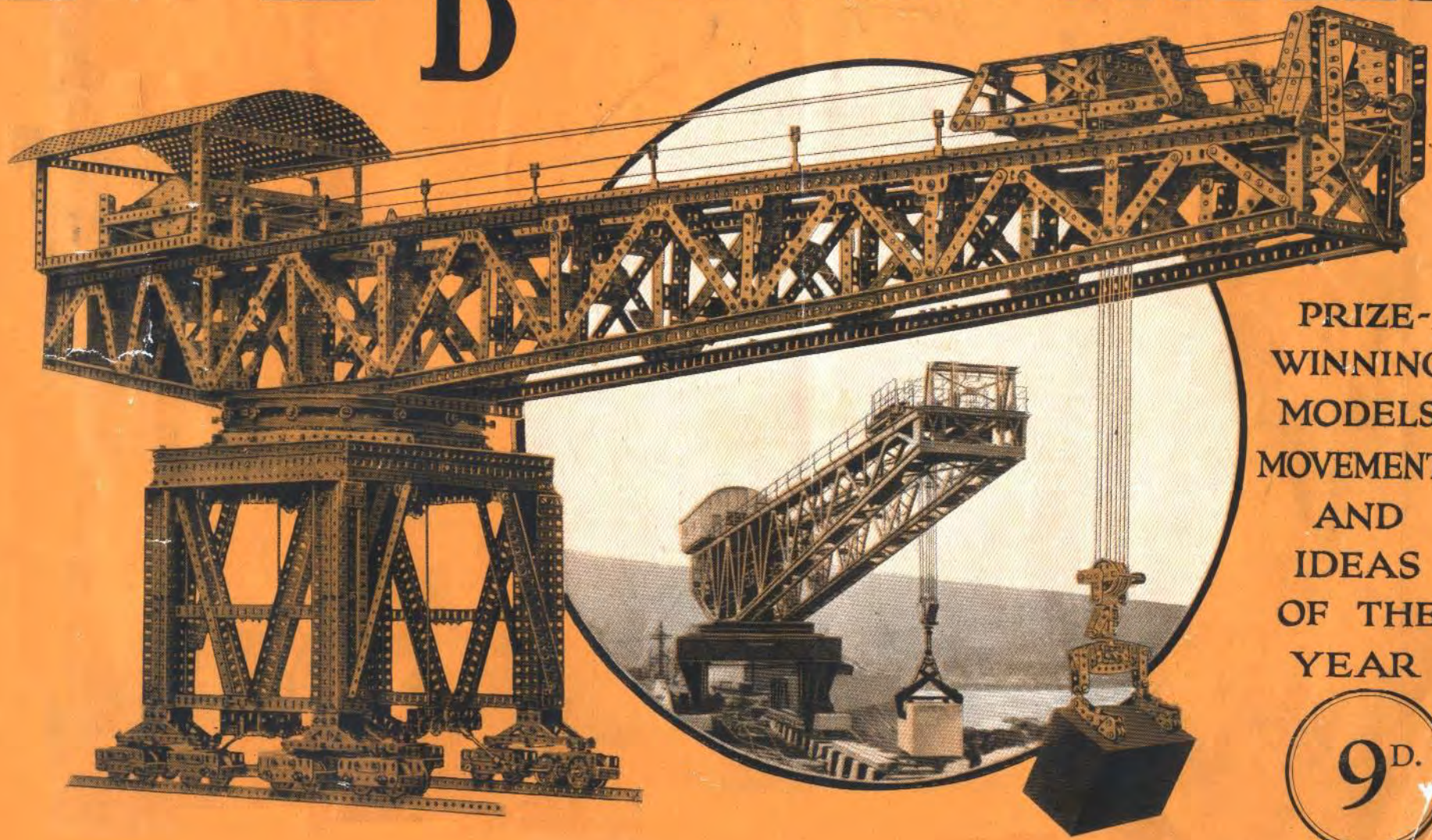

PRIZE-  
WINNING  
MODELS,  
MOVEMENTS  
AND  
IDEAS  
OF THE  
YEAR

9<sup>d.</sup>



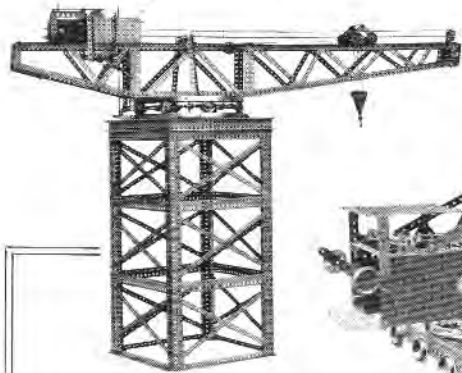

## What shall I build next?

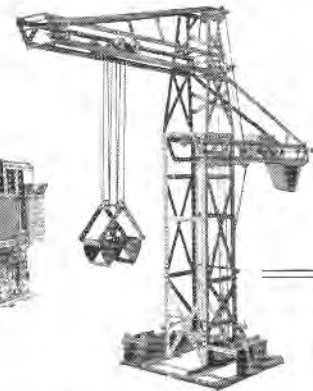
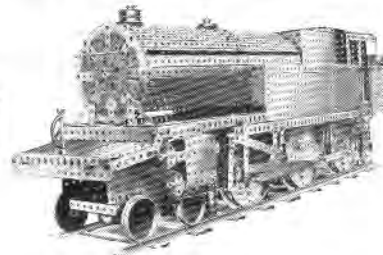
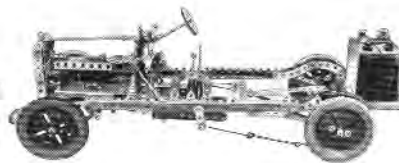
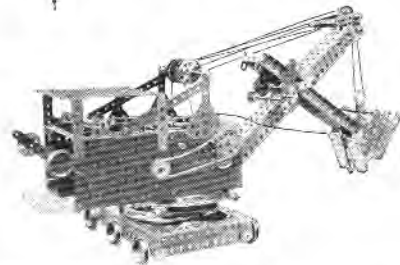

**T**HE question "What shall I build next?" is constantly in the minds of all keen Meccano boys. They never say "I wish I could build something new!" They often have such a vast store of new ideas packed away in their minds that they wish they could build three or four models simultaneously and so put their latest "brainwaves" into tangible form before they are ousted by still more new ones!

In view of this it might be wondered why we appear always to be designing new models for them. But it can scarcely be said that we do so, for Meccano boys themselves keep us supplied with as many new models, new suggestions, and new Meccano improvements as we can cope with. We merely add the final polish and publish the models or ideas in a convenient form so that each Meccano boy may become acquainted with his fellow-enthusiasts' work. Nearly every model shown in this special Meccano Manual is the direct outcome of some prize-winning entry in a Model-building Competition. Of course, few models are reproduced exactly as they are submitted by their designers—as a matter of fact several of the new models shown in these pages incorporate the ideas of three or four different Meccano boys.

Large numbers of new models, suggestions and bright ideas reach us every day in connection with the special Model-building Competitions that are announced from time to time in the "Meccano Magazine" and it is the task of our Model-building Department to select the best and to revise them so that hundreds of thousands of Meccano boys may benefit from their publication.

It should be understood that this Manual is entirely supplementary to the ordinary Instruction Manuals, and most of the models shown are published for the first time. New Meccano boys should commence their model-building with the aid of the Instruction Manuals, in which the models are arranged progressively according to the sizes of the Outfits with which they may be built.

Model-builders will note that a number of recent additions to the Meccano system are used in the models shown, and for the benefit of those boys who are not yet familiar with all the new parts we have included a list of the latest additions (see page iii of cover). Many of the models show the new

style  $5\frac{1}{2}'' \times 2\frac{1}{8}''$  Flanged Plates (with flanges at the ends as well as at the sides) and improved Sector Plates (with two additional rows of holes), but it may be noted that, although the new parts are more adaptable, the old style plates may still be used in their place if desired.

When it is required to journal an Axle Rod in a slot in the new Flanged Plates, an ordinary Strip should first be bolted to the Plate so that one of its holes forms an additional bearing for the Rod.

It will be noticed that in building Meccano models, it is frequently required to attach two parts together so that one or both are quite free to swivel. A very simple way to do this is shown under detail No. 262 in the Meccano Standard Mechanisms Manual, and for the benefit of those readers who are unable to consult the special Manual, we may say that this particular "S.M." consists of a simple type of pivot, or swivel bearing, formed by a bolt and two nuts. The bolt is secured rigidly to a Strip or Plate, etc., by means of the nuts, which are screwed tightly against opposite sides of the Strip, sufficient space being left beneath the head of the bolt to permit another Strip to turn freely about its shank.

A somewhat similar form of swivel-joint, also widely used, consists of a bolt and lock-nuts (S.M. 263). The two Strips to be connected pivotally are placed on the bolt and held in position by two nuts locked together on the shank. The Strips must be allowed a certain amount of play so that they can pivot independently about the bolt. These pivoting devices will be found equally valuable in the simplest and the most elaborate models.

In addition to several useful items of a similar nature to the two described above, the Standard Mechanisms Manual contains a large number of Meccano movements that may be adapted with advantage to numerous models. It is divided into thirteen different sections and the subjects dealt with include gear ratios, belt and rope mechanisms, pulleys, levers, drive-changing mechanisms, brakes, roller and ball bearings, steering gear, screw mechanisms, traversing mechanisms, grabs and dredging apparatus, variable speed gear, reciprocating engine mechanism, etc., etc. The Meccano Standard Mechanisms Manual may be obtained through any Meccano dealer, price 1/6, or from Models Ltd., Kingston Street (P.O. Box 129), Auckland, 1/7 $\frac{1}{2}$ , post free.



# NEW MECCANO MODELS

**Model No. 1**  
**Mail Bag**  
**Hanger**

Parts  
required :

2 of No.	2
1 " "	10
14 " "	37
1 " "	52
1 " "	57
2 " "	90A
2 " "	126



**Model No. 2 Mechanical Hack Saw**

Parts required :

1 of No.	2	1 of No.	24	2 of No.	48A
1 " "	5	1 " "	35	1 " "	52
2 " "	11	16 " "	37	4 " "	90A
1 " "	19s	1 " "	37A	2 " "	126

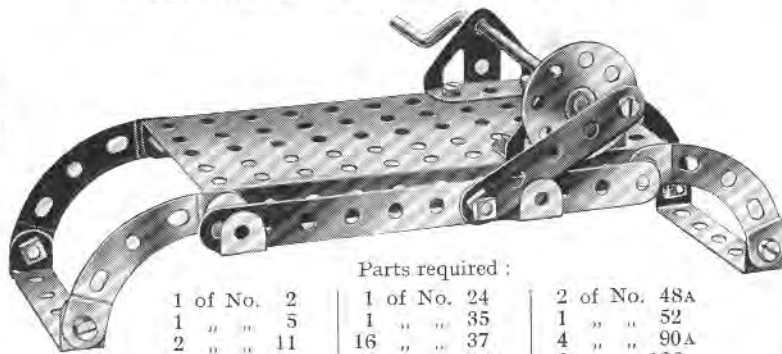

**Model No. 3 Ore Crusher**

Parts  
required :

6 of No.	5	1 of No.	24
2 " "	10	2 " "	35
1 " "	16	17 " "	37
1 " "	19s	2 " "	48A
2 " "	22	1 " "	52
		1 " "	125
		2 " "	126

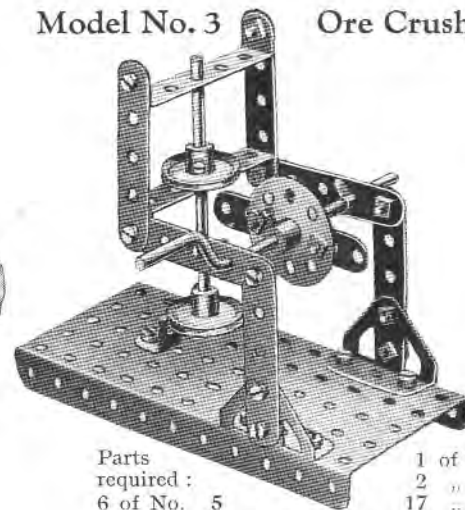

**Model No. 4 Old Siege Gun**

Parts  
required :

3 of No.	2
1 " "	5
2 " "	11
4 " "	12
2 " "	16
4 " "	22
1 " "	24
18 " "	37
2 " "	48A
1 " "	52
4 " "	90A

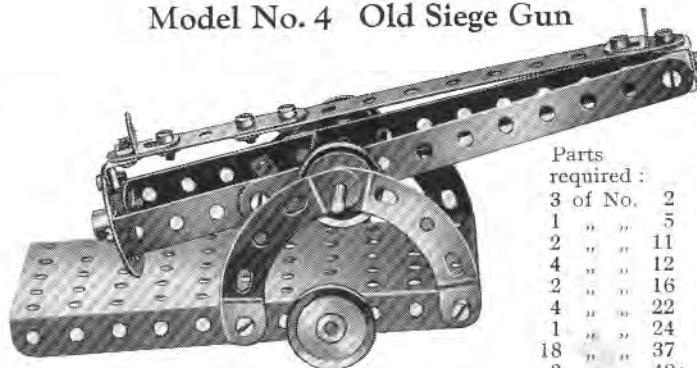

**Model No. 5 Garden Hose**  
**Reel**

Parts  
required :

2 of No.	2
2 " "	5
1 " "	16
1 " "	19s
4 " "	22
14 " "	37
1 " "	48A
2 " "	90A
2 " "	126
2 " "	126A

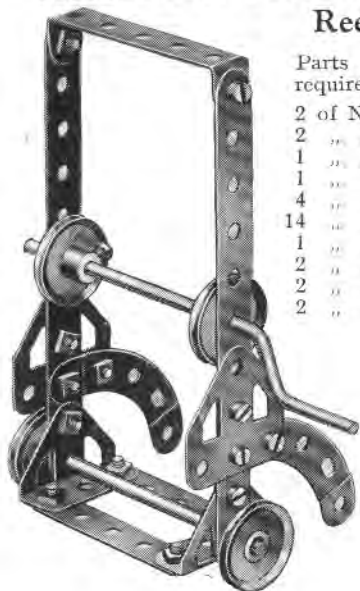

**Model No. 6 Push Cart**

Parts required :

2 of No.	16	1 of No.	52
4 " "	22	4 " "	90A
16 " "	37	2 " "	126
2 " "	48A	2 " "	126A

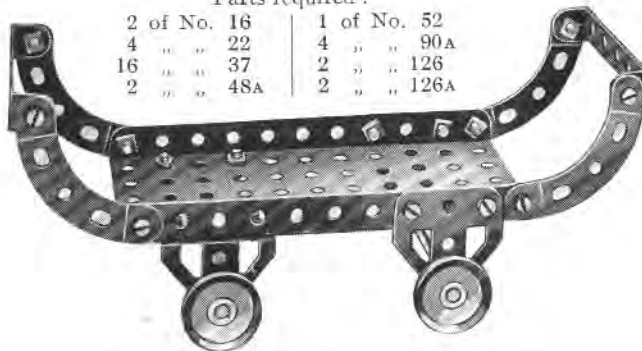

**Model No. 7 Bed Table**

Parts required :

3 of No.	2	4 of No.	22
1 " "	5	1 " "	24
2 " "	11	3 " "	35
3 " "	12	15 " "	37
2 " "	16	2 " "	48A
1 " "	17	1 " "	52

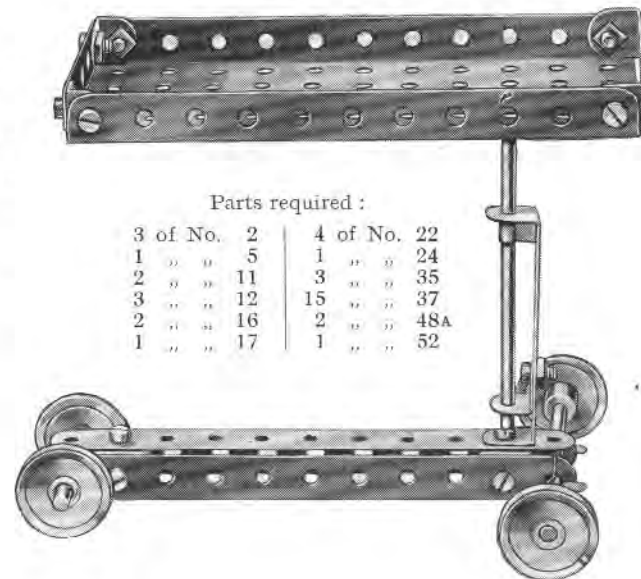

**Model No. 8 Trip Hammer**

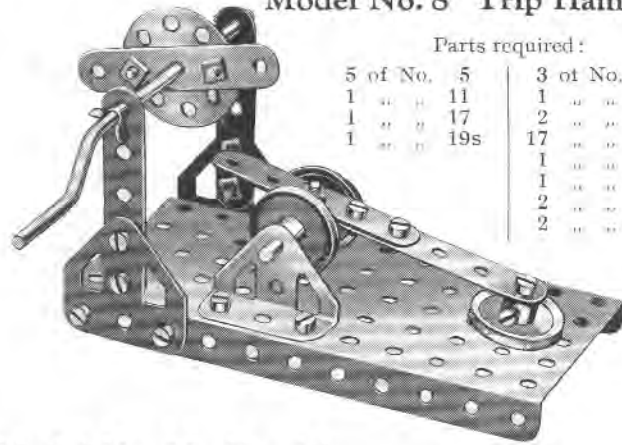

Parts required :

5 of No. 5	3 of No. 22
1 " " 11	1 " " 24
1 " " 17	2 " " 35
1 " " 19s	17 " " 37
	1 " " 52
	1 " " 111c
	2 " " 126
	2 " " 126A

**Model No. 9 Revolving Office Chair**

Parts required :

3 of No. 5
1 " " 12
1 " " 17
2 " " 22
1 " " 24
18 " " 37
2 " " 48A
4 " " 90A
2 " " 126
1 " " 126A



**Model No. 10 Ski-runner**

Parts required :

2 of No. 2
3 " " 5
1 " " 10
4 " " 12
2 " " 16
3 " " 22
4 " " 35
11 " " 37
1 " " 126A

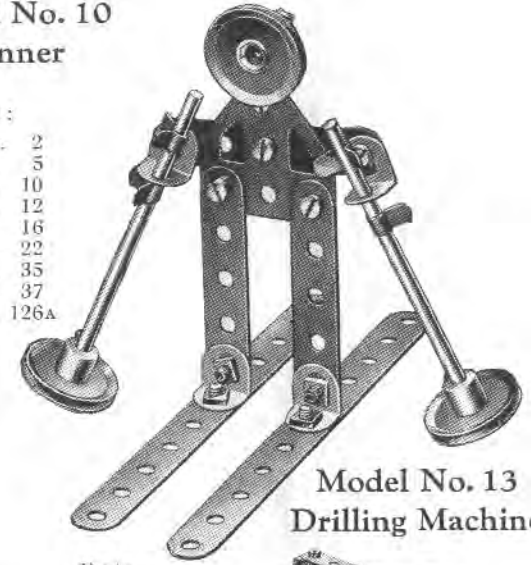

**Model No. 11 Derrick**

Parts required :

4 of No. 2	1 of No. 52
5 " " 5	1 " " 57
1 " " 10	2 " " 125
2 " " 11	2 " " 126
1 " " 16	
1 " " 17	
1 " " 19s	
3 " " 22	
1 " " 23	
2 " " 35	
22 " " 37	
2 " " 48A	

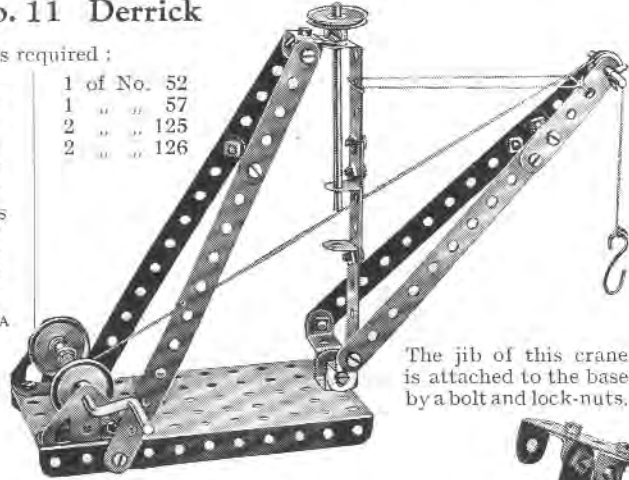

The jib of this crane is attached to the base by a bolt and lock-nuts.

**Model No. 12 Cot on Wheels**

Parts required :

2 of No. 2	2 of No. 48A
5 " " 5	1 " " 52
3 " " 12	2 " " 90A
4 " " 22	2 " " 100
18 " " 37	

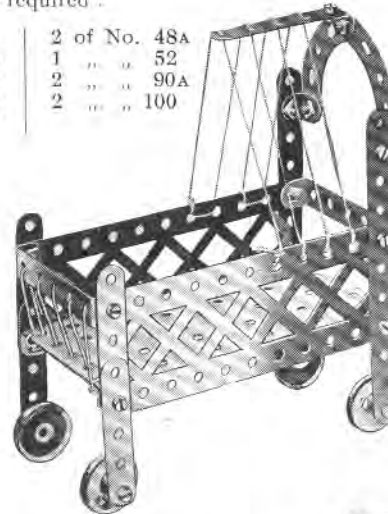

**Model No. 13 Drilling Machine**

Parts required :

3 of No. 2
4 " " 5
1 " " 11
3 " " 12
1 " " 16
1 " " 17
1 " " 19s
4 " " 22
1 " " 24
6 " " 35
22 " " 37
2 " " 48A
1 " " 52
1 " " 125
2 " " 126A

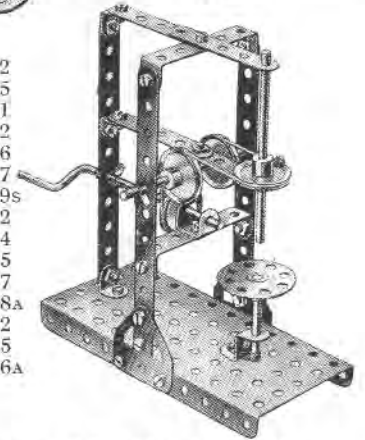

**Model No. 14 Well-Boring Machine**

Parts required :

4 of No. 2	2 of No. 12
4 " " 5	1 " " 16
1 " " 10	2 " " 17
	1 " " 19s
	4 " " 22
	1 " " 24
	1 " " 35
	19 " " 37
	1 " " 52
	1 " " 126
	2 " " 126A

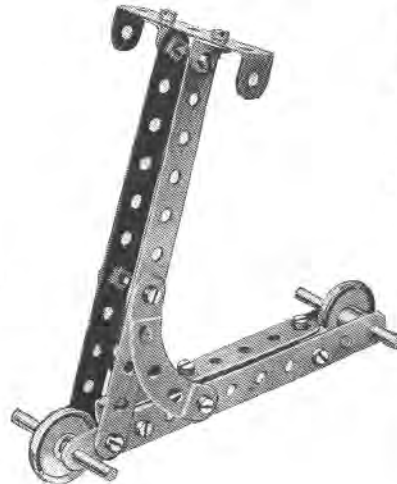
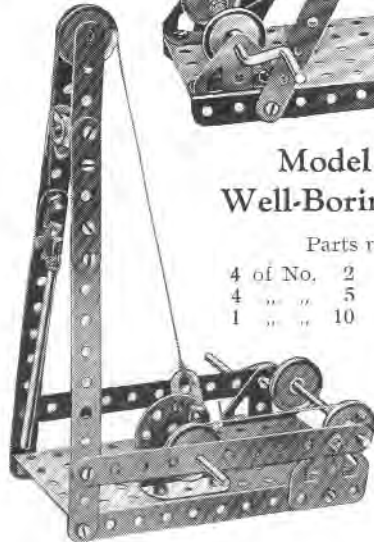

**Model No. 15 Scooter**

Parts required :

4 of No. 2	2 of No. 22
2 " " 5	17 " " 37
2 " " 11	1 " " 48A
2 " " 12	2 " " 90A
2 " " 17	

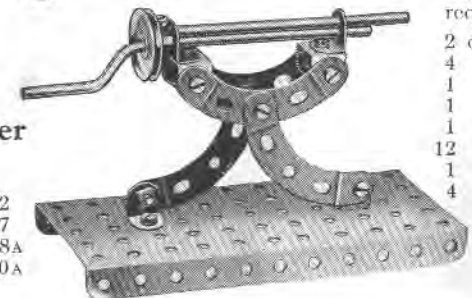

**Model No. 16 Rock Drill**

Parts required :

2 of No. 11
4 " " 12
1 " " 16
1 " " 19s
1 " " 22
12 " " 37
1 " " 52
4 " " 90A



Model No. 17 Letter Balance

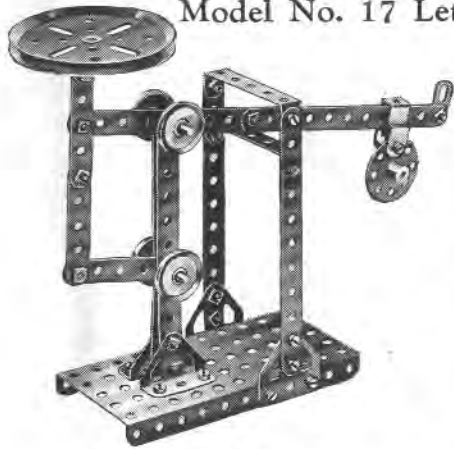

Parts required:	
6 of No.	2
3 " "	5
1 " "	10
1 " "	12
2 " "	18A
1 " "	19B
4 " "	22
1 " "	24
29 " "	37
2 " "	37A
2 " "	38
1 " "	44
2 " "	48A
1 " "	52
2 " "	111c
2 " "	126
2 " "	126A

Model No. 18 Mechanical Stamp

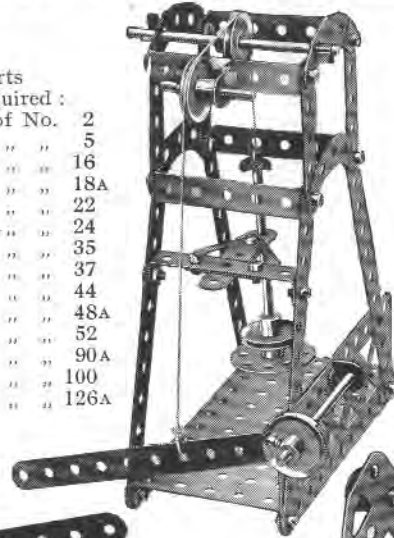

Parts required:	
5 of No.	2
5 " "	5
3 " "	16
1 " "	18A
4 " "	22
1 " "	24
6 " "	35
20 " "	37
1 " "	44
6 " "	48A
1 " "	52
4 " "	90A
1 " "	100
1 " "	126A

Model No. 19 Blacksmith

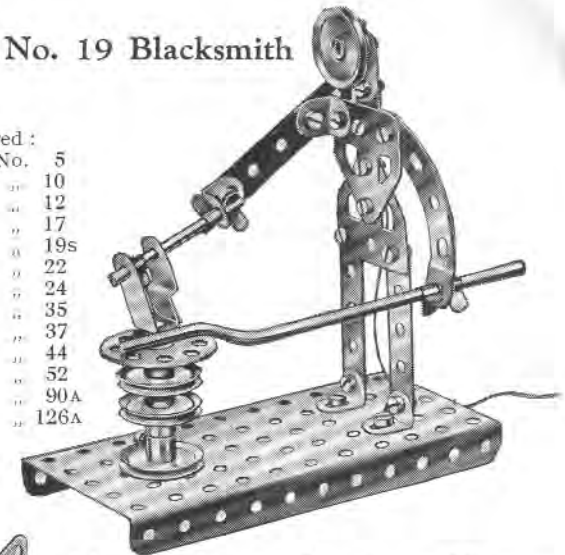

Parts required:	
3 of No.	5
2 " "	10
4 " "	12
2 " "	17
1 " "	19s
4 " "	22
1 " "	24
6 " "	35
15 " "	37
1 " "	44
1 " "	52
1 " "	90A
2 " "	126A

Model No. 20 Automatic Signal

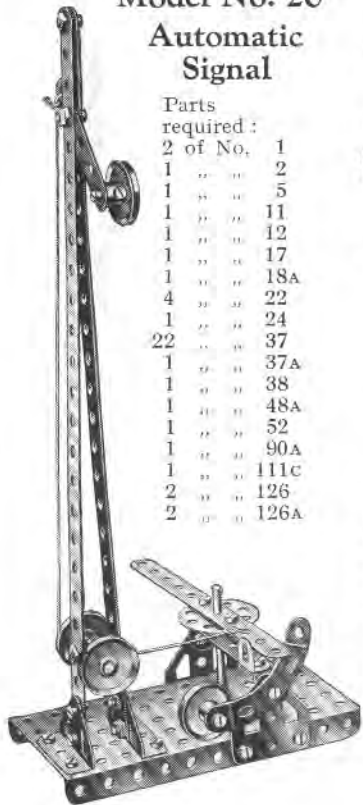

Parts required:	
2 of No.	1
1 " "	2
1 " "	5
1 " "	11
1 " "	12
1 " "	17
1 " "	18A
4 " "	22
1 " "	24
22 " "	37
1 " "	37A
1 " "	38
1 " "	48A
1 " "	52
1 " "	90A
1 " "	111c
2 " "	126
2 " "	126A

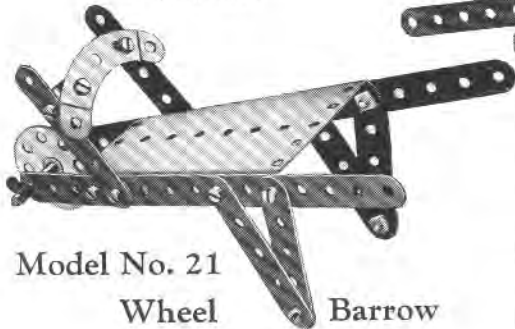

Model No. 21 Wheel Barrow

Parts required:	
2 of No.	2
8 " "	5
2 " "	12
1 " "	17
1 " "	24
2 of No.	35
14 " "	37
1 " "	54
1 " "	90A

The weighted Curved Strip normally holds the end of the 5½" Strip against an Angle Bracket, allowing the signal arm to fall to the "all clear" position. Any train passing the signal, however, strikes the opposite end of the 5½" Strip, and by means of the cord shown, raises the arm to indicate "danger." The Curved Strip moves to allow the end of the 5½" Strip to pass over it, and is returned to its original position by reason of its weighted end. The signal then remains at "danger" until the mechanism is re-set.

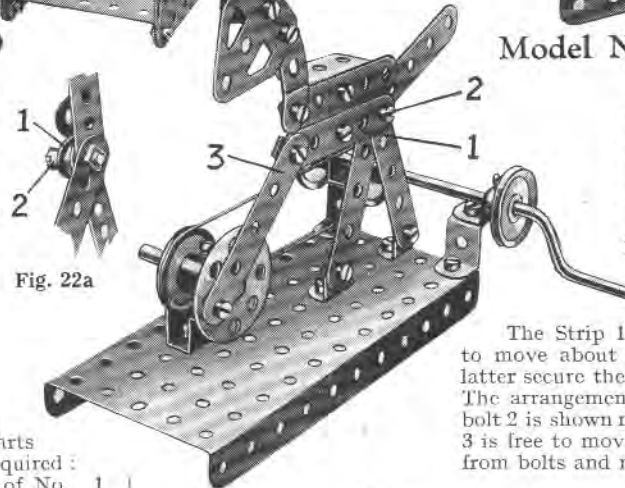

Model No. 22 Prancing Horse

Parts required:	
6 of No.	5
4 " "	12
1 " "	17
1 " "	19s
4 " "	22
1 " "	24
16 " "	37
1 of No.	44
1 " "	52
1 " "	90A
1 " "	111c
2 " "	125
1 " "	126
1 " "	126A

Fig. 22a

The Strip 1 forming part of the body is free to move about the bolt 2, but two nuts on the latter secure the rear legs and tail rigidly together. The arrangement of the various Strips about this bolt 2 is shown more clearly in Fig. 22a. The Strip 3 is free to move at each end about pivots formed from bolts and nuts.

Parts required:	
4 of No.	1
6 " "	5
2 " "	11
2 " "	12
1 " "	16
1 " "	17
1 " "	19s
4 " "	22
1 " "	24
4 " "	35
23 " "	37
1 " "	44
3 " "	48A
1 of No.	52
2 " "	125
2 " "	126A

Model No. 23 Helve Hammer

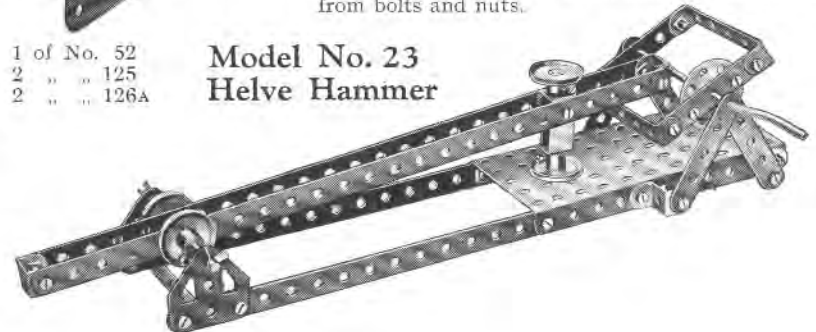

Model No. 24 Horizontal Engine

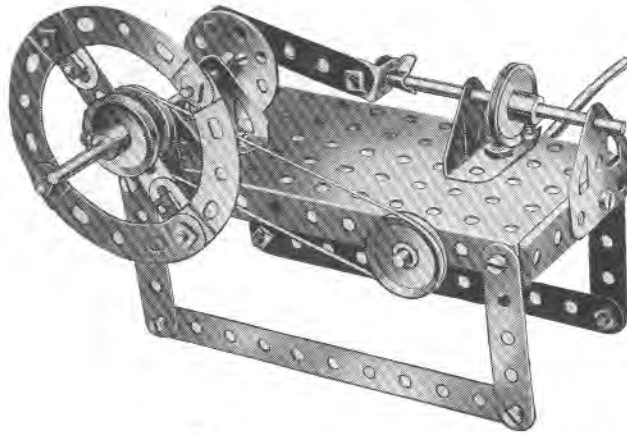

Parts required :

2 of No.	2
6 " "	5
1 " "	10
1 " "	12
2 " "	16
1 " "	19s
4 " "	22
1 " "	24
3 " "	35
21 " "	37
1 " "	48A
1 " "	52
4 " "	90A
2 " "	126
2 " "	126A

Model No. 25 Aeroplane

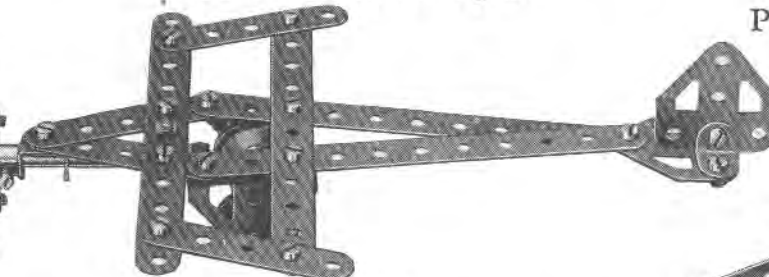

Parts required :

4 of No.	2	1 of No.	16	1 of No.	35
5 " "	5	1 " "	17	18 " "	37
1 " "	11	2 " "	22	2 " "	126
2 " "	12	1 " "	24	2 " "	126A

Model No. 26 Punching Machine

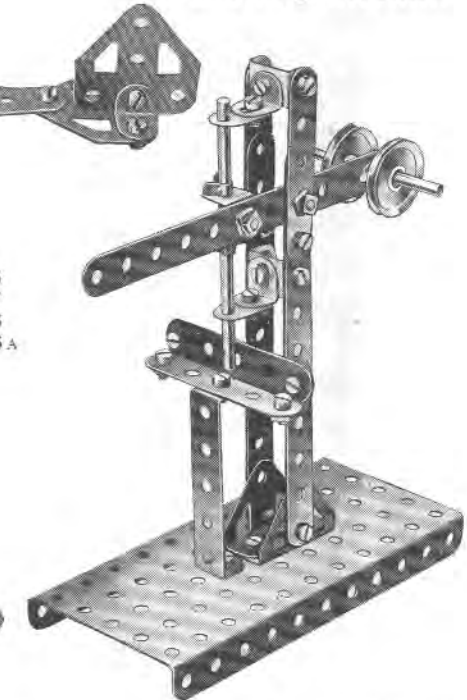

Parts required :

2 of No.	11	2 of No.	35
2 " "	12	22 " "	37
1 " "	16	1 " "	48A
1 " "	17	1 " "	52
2 " "	22	2 " "	126

Model No. 27 Pulley Block

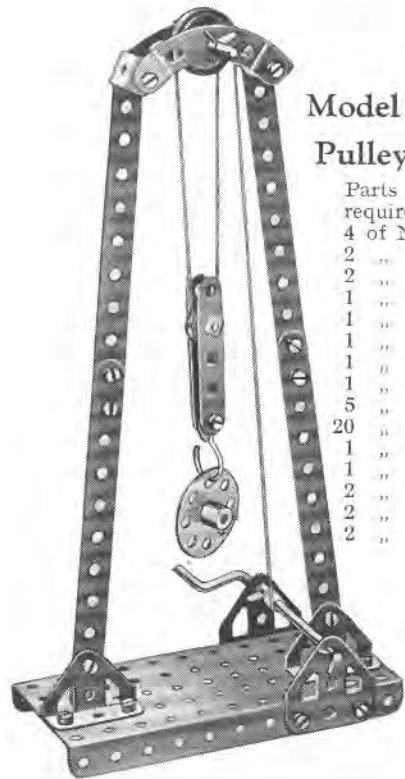

Parts required :

4 of No.	2
2 " "	5
2 " "	11
1 " "	17
1 " "	19s
1 " "	22
1 " "	23
1 " "	24
5 " "	35
20 " "	37
1 " "	52
1 " "	57
2 " "	90A
2 " "	126
2 " "	126A

Model No. 29 Swivelling Crane

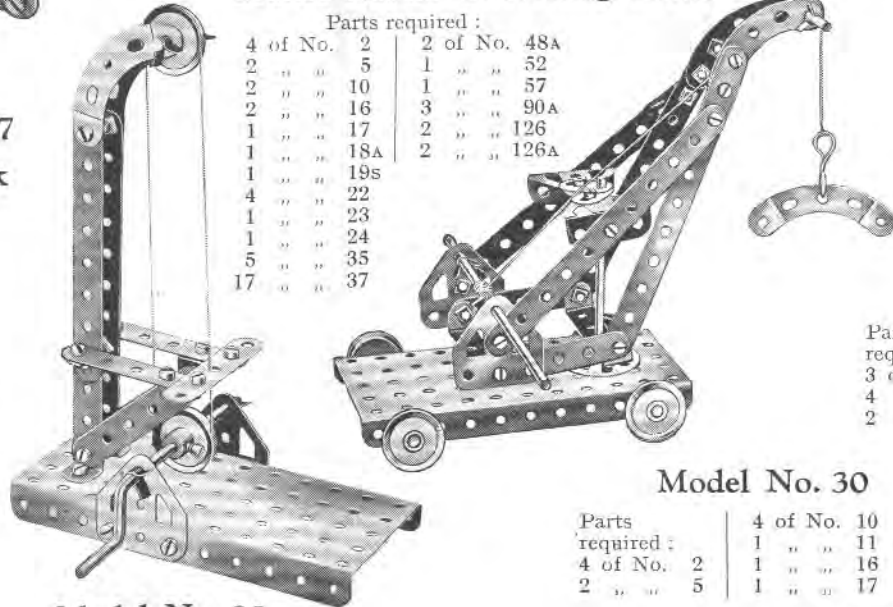

Parts required :

4 of No.	2	2 of No.	48A
2 " "	5	1 " "	52
2 " "	10	1 " "	57
2 " "	16	3 " "	90A
1 " "	17	2 " "	126
1 " "	18A	2 " "	126A
1 " "	19s		
4 " "	22		
1 " "	23		
1 " "	24		
5 " "	35		
17 " "	37		

Model No. 30

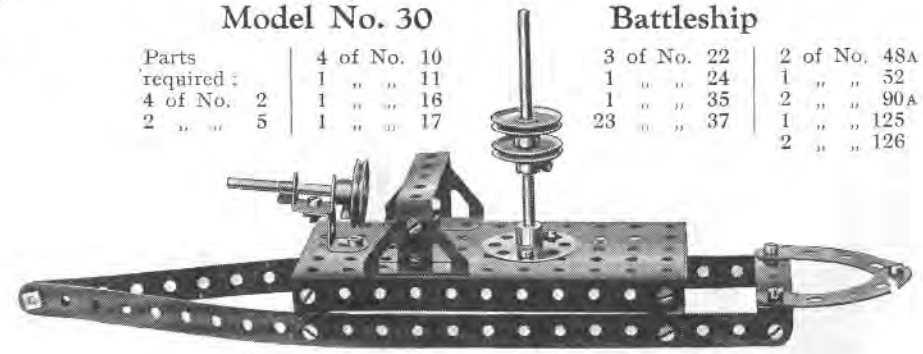

Parts required :

4 of No.	10
1 " "	11
1 " "	16
1 " "	17

Battleship

Parts required :

3 of No.	22	2 of No.	48A
1 " "	24	1 " "	52
1 " "	35	2 " "	90A
23 " "	37	1 " "	125
		2 " "	126

Model No. 28 Band Saw

Parts required :

2 of No.	2	4 of No.	35
5 " "	5	20 " "	37
6 " "	12	1 " "	52
1 " "	17	2 " "	90A
1 " "	19	2 " "	126A
2 " "	22		

**Model No. 31**  
**Boy on Swing**

Parts required:	
4 of No.	1
6 " "	2
2 " "	5
5 " "	10
8 " "	12
2 " "	16
1 " "	17
4 " "	22
1 " "	24
5 " "	35
35 " "	37
1 " "	48A
1 " "	52
1 " "	54
2 " "	125
2 " "	126A

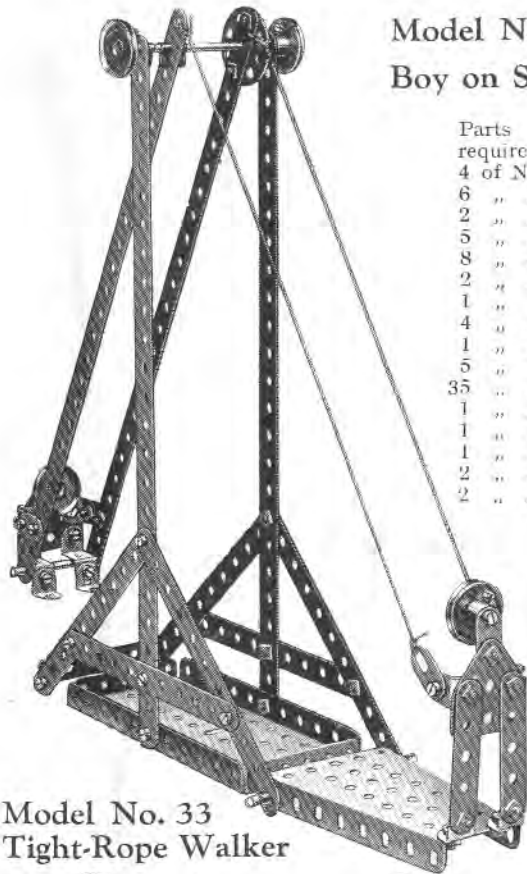

**Model No. 32 Mechanical Shovel**

Parts required:	
4 of No.	1
6 " "	2
5 " "	5
2 " "	11
3 " "	16
1 " "	18A
1 " "	19B
1 " "	19s
4 " "	22
1 " "	23
1 " "	24
6 " "	35
35 " "	37

1 of No.	37A
1 " "	38
1 " "	48
6 " "	48A
1 " "	52
2 " "	54
1 " "	126A

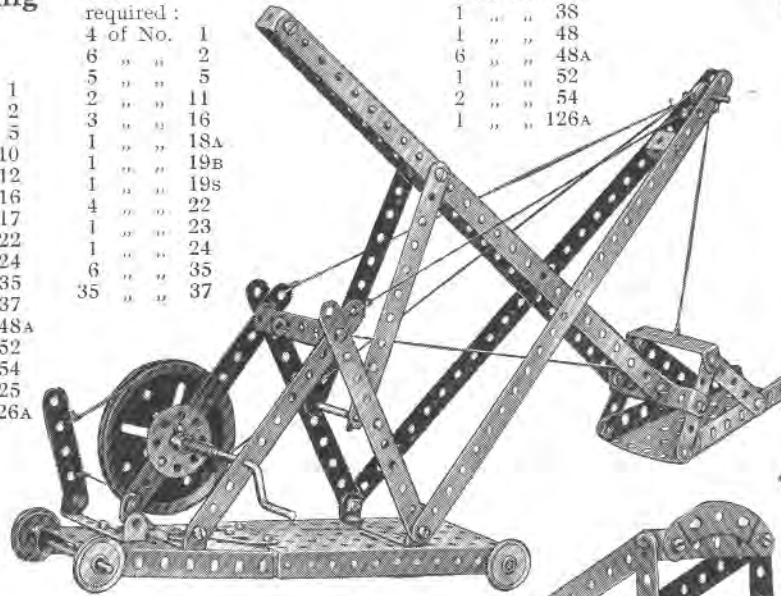

**Model No. 35**  
**Swivelling Crane**

Parts required:	
2 of No.	1
6 " "	2
6 " "	5
2 " "	11
1 " "	12
1 " "	16
1 " "	17
3 " "	19B
1 " "	19s
4 " "	22
1 " "	24
2 " "	35
25 " "	37
1 " "	37A
2 " "	48A
1 " "	52
1 " "	54
1 " "	57
2 " "	90A
1 " "	111c

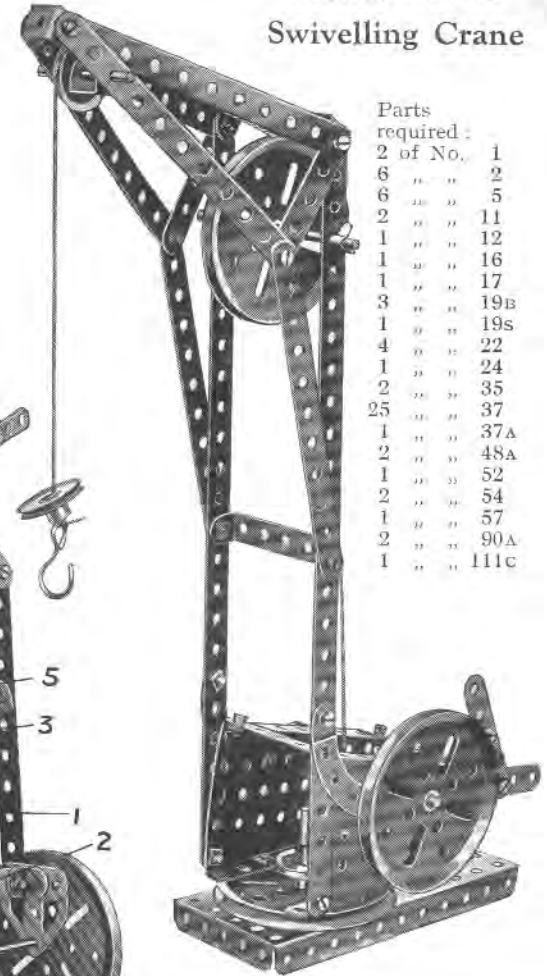

**Model No. 33**  
**Tight-Rope Walker**

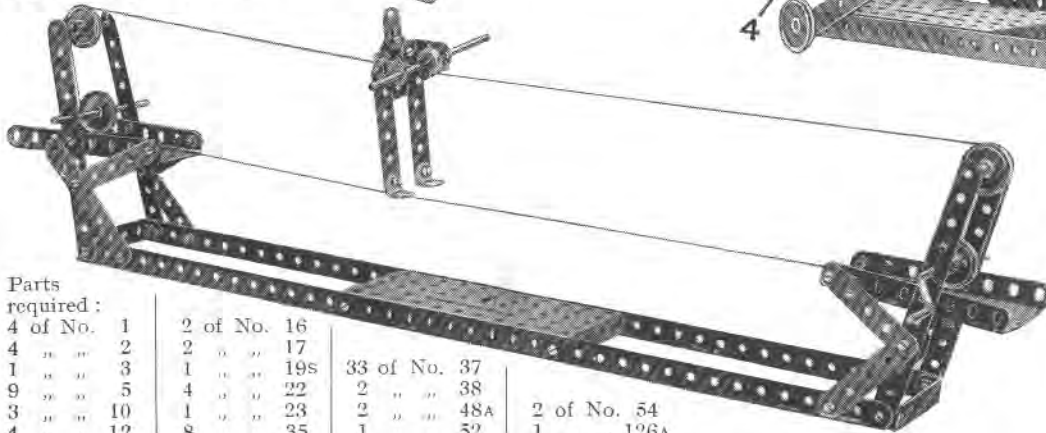

Parts required:	
4 of No.	1
4 " "	2
1 " "	3
9 " "	5
3 " "	10
4 " "	12
2 of No.	16
2 " "	17
1 " "	19s
4 " "	22
1 " "	23
1 " "	24
8 " "	35
33 of No.	37
2 " "	38
2 " "	48A
1 " "	52
2 of No.	54
1 " "	126A

**Model No. 34**  
**Ballista**

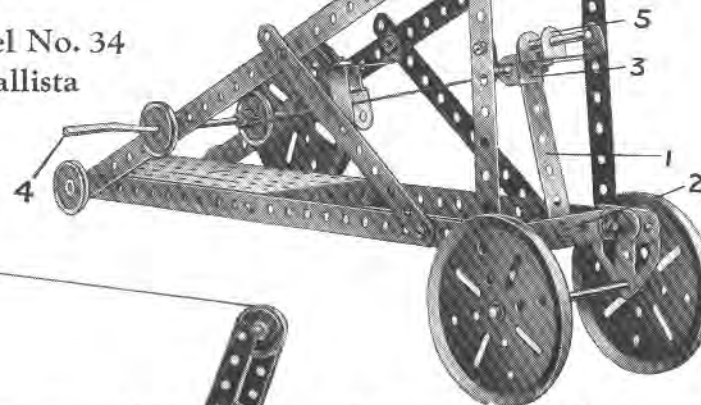

Parts required:	
1 of No.	1
4 " "	2
1 " "	3
2 " "	11
2 " "	12
2 " "	16
1 " "	18A
4 of No.	19B
1 " "	19s
4 " "	22
21 " "	37
1 " "	44
4 " "	48A
1 " "	52
1 " "	90A
2 " "	126A

This is a model of an ancient engine of war, resembling the crossbow. The 3 1/2" Strip 1 is bolted firmly to the Double Angle Strip 2, which is prevented from turning by the addition of Angle Brackets as shown. A Double Bracket 3 slides on the Strip 1 and is secured to a piece of cord. On rotation of the Crank Handle 4, the Strip 1 is pulled backward until the Double Bracket 3 slips off its end. The Strip then flies forward and strikes the missile, which consists of a 2" Rod placed ready in the Double Bracket 5.



### Model No. 36 Motor Tractor

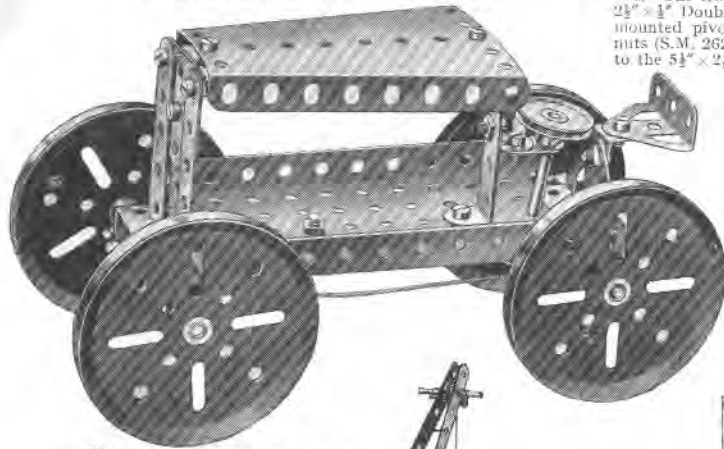

The steering gear is shown in Fig. 36a. The front wheels are carried in a  $2\frac{1}{2} \times 1$ " Double Angle Strip 1, which is mounted pivotally by a bolt and two nuts (S.M. 262) to a  $2\frac{1}{2}$ " Strip 2 secured to the  $5\frac{1}{2} \times 2\frac{1}{2}$ " Flanged Plate.

Parts required:

3 of No. 5	2 of No. 37A
1 " " 10	6 " " 38
2 " " 12	4 " " 48A
2 " " 16	1 " " 52
1 " " 18A	1 " " 54
4 " " 19B	1 " " 111C
1 " " 22	2 " " 126
1 " " 24	1 " " 126A
15 " " 37	

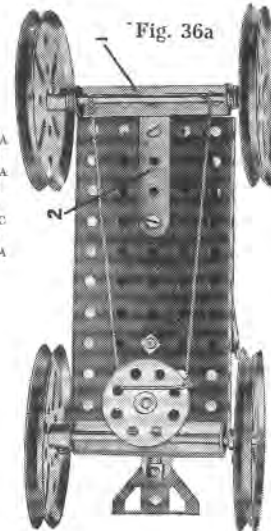

### Model No. 37 Travelling Crane

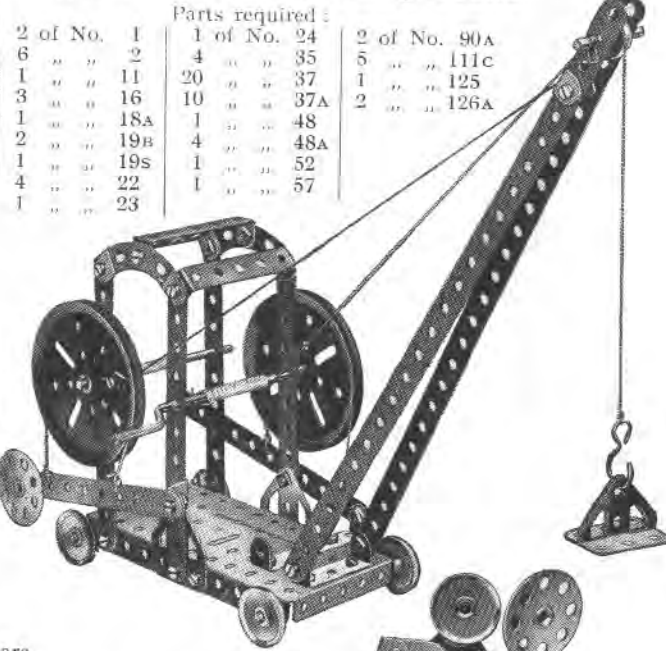

Parts required:

2 of No. 1	1 of No. 24	2 of No. 90A
6 " " 2	4 " " 35	5 " " 111c
1 " " 11	20 " " 37	1 " " 125
3 " " 16	10 " " 37A	2 " " 126A
1 " " 18A	1 " " 48	
2 " " 19B	4 " " 48A	
1 " " 19S	1 " " 52	
4 " " 22	1 " " 57	
1 " " 23		

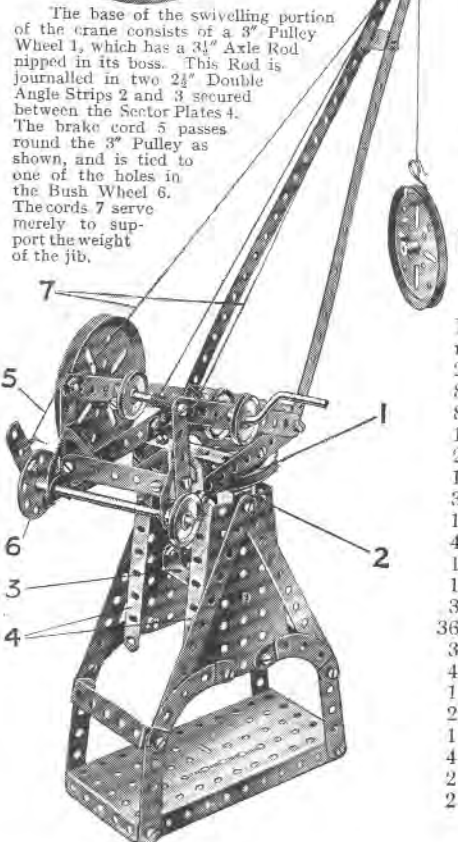

The base of the swivelling portion of the crane consists of a 3" Pulley Wheel 1, which has a  $3\frac{1}{2}$ " Axle Rod slipped in its boss. This Rod is journaled in two  $2\frac{1}{2}$ " Double Angle Strips 2 and 3 secured between the Sector Plates 4. The brake cord 5 passes around the 3" Pulley as shown, and is tied to one of the holes in the Bush Wheel 6. The cords 7 serve merely to support the weight of the jib.

### Model No. 38 Elevated Crane

Parts required:

2 of No. 1
8 " " 2
8 " " 5
1 " " 11
2 " " 16
1 " " 18A
3 " " 19B
1 " " 19S
4 " " 22
1 " " 23
1 " " 24
3 " " 35
36 " " 37
3 " " 38
4 " " 48A
1 " " 52
2 " " 54
1 " " 57
4 " " 90A
2 " " 126
2 " " 126A

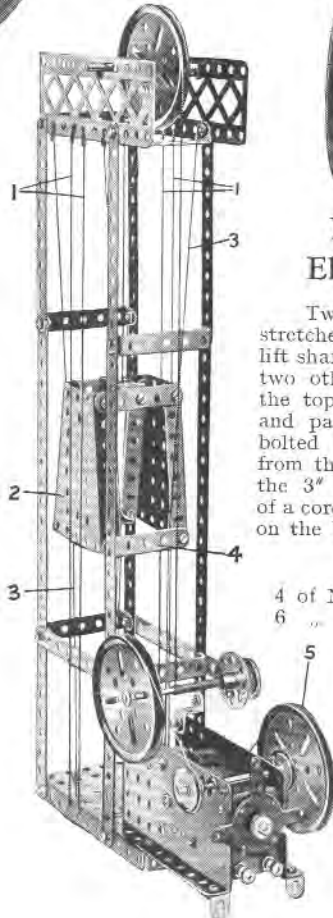

### Model No. 39 Electric Elevator

Two pairs of cords 1 are stretched tightly on each side of the lift shaft to guide the cage 2 and two other cords 3 are secured at the top and bottom of the shaft and passed behind  $2\frac{1}{2}$ " Strips 4 bolted to the cage. The drive from the Motor is transmitted to the 3" Pulley Wheel 5 by means of a cord passed round a  $\frac{1}{2}$ " Pulley on the Motor armature.

Parts required:

4 of No. 1	4 of No. 5
6 " " 2	2 " " 12
	3 " " 16
	3 " " 19B
	4 " " 22
	1 " " 24
	3 " " 35
	34 " " 37
	1 " " 38
	1 " " 48
	6 " " 48A
	1 " " 52
	2 " " 54
	2 " " 100
	2 " " 125

### Model No. 40 Man and Boy



Parts required:

4 of No. 2
1 " " 3
1 " " 5
5 " " 10
1 " " 11
8 " " 12
1 " " 22
1 " " 24
26 " " 37
1 " " 52
2 " " 54
1 " " 90A
2 " " 125
1 " " 126A

New Meccano models appear every month in the "Meccano Magazine." See back of cover.



### Model No. 41 Twin-Engine Biplane

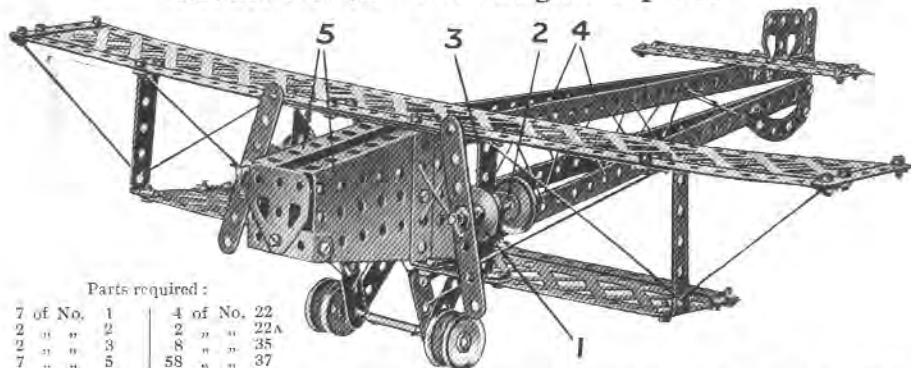

Parts required:

7 of No. 1	4 of No. 22
2 " " 2	2 " " 22A
2 " " 3	8 " " 35
7 " " 5	58 " " 37
2 " " 6A	6 " " 38
8 " " 10	1 " " 48
2 " " 11	6 " " 48A
8 " " 12	2 " " 54
1 " " 16	1 " " 90A
2 " " 17	2 " " 126A
2 " " 20	

Each engine is represented by a  $\frac{1}{2}$ " Flanged Wheel 1 and a 1" fast Pulley Wheel secured to a 2" Rod-journalled in a Double Bracket 2, which is bolted to the  $2\frac{1}{4}$ " x  $\frac{1}{2}$ " vertical Double Angle Strip 3. The  $12\frac{1}{4}$ " Strips 4 of the fuselage proper are bolted to the two Sector Plates 5, and also by means of Angle Brackets to the wings. The tail plane consists of two  $5\frac{1}{2}$ " Strips to which a similar Strip, representing the movable portion of the plane, is attached by means of Flat Brackets.

### Model No. 42 Gondola

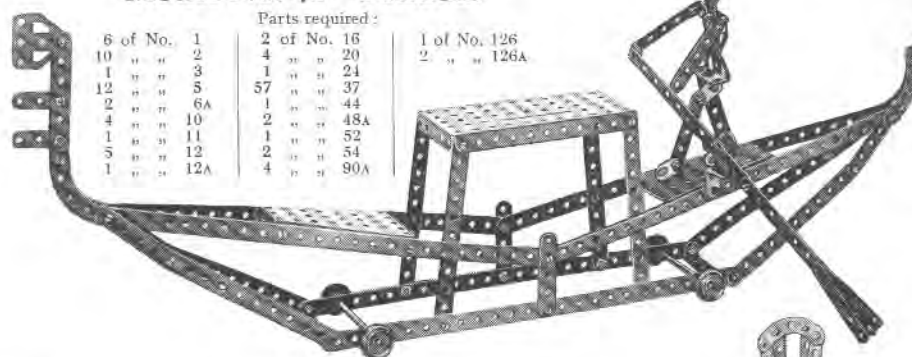

Parts required:

6 of No. 1	2 of No. 16	1 of No. 126
10 " " 2	4 " " 20	2 " " 126A
1 " " 3	1 " " 24	
12 " " 5	57 " " 37	
2 " " 6A	1 " " 44	
4 " " 10	2 " " 48A	
1 " " 11	1 " " 52	
5 " " 12	2 " " 54	
1 " " 12A	4 " " 90A	

### Model No. 44 Try-Your-Strength Machine

The Bush Wheel 1 is secured to a short Axle Rod 2, the lower end of which rests on a pair of Angle Brackets 3 bolted to the ends of four  $5\frac{1}{2}$ " Strips 4. The Strips 4 are pivoted as shown (Fig. 44b) on a  $1\frac{1}{2}$ " Rod 5, and on their opposite ends rests a  $\frac{1}{2}$ " loose Pulley Wheel 6. When the Bush Wheel 1 is struck, the  $5\frac{1}{2}$ " Strips fling the Pulley Wheel 6 upward, but the wheel is guided by the vertical  $12\frac{1}{4}$ " Strips 7. The weight of the Strips 4 then causes the Bush Wheel to resume its original position.

### Model No. 43 Anti-Aircraft Gun

The general construction of the model will be made clear by reference to Figures 43a and 43b. Rotation of the handle 1 causes the gun to revolve on the 3" Pulley Wheel 2. The barrel of the gun is so balanced on the Axle Rod 3 that it tends to fall by its own weight, but is prevented from doing so by a cord 4 tied to the gun close to the breech and wound on the  $3\frac{1}{2}$ " Rod 5. By turning the Pulley Wheels 6 the muzzle is raised or allowed to fall.



Parts required:

9 of No. 2	8 of No. 35
1 " " 6A	57 " " 37
1 " " 8	6 " " 38
4 " " 10	1 " " 45
3 " " 11	4 " " 48A
5 " " 12	1 " " 52
4 " " 16	2 " " 54
2 " " 17	4 " " 90A
1 " " 19B	1 " " 115
4 " " 20	2 " " 126
4 " " 22	2 " " 126A
1 " " 24	

Fig. 43a

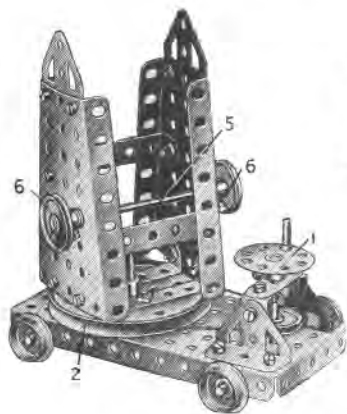

Fig. 43b

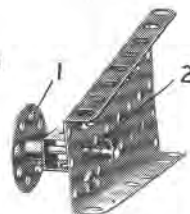

Fig. 44a

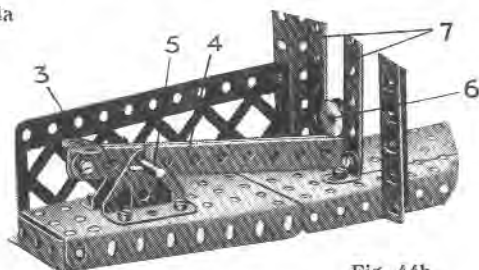
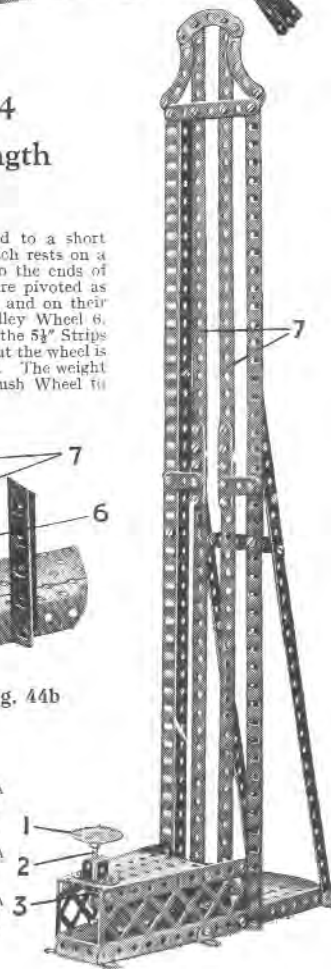

Fig. 44b

Parts required:

6 of No. 1	60 of No. 37
6 " " 2	6 " " 37A
1 " " 3	4 " " 38
2 " " 5	1 " " 45
2 " " 6A	1 " " 48
4 " " 8	1 " " 48A
2 " " 10	1 " " 52
10 " " 12	2 " " 54
2 " " 18A	3 " " 90A
1 " " 23	2 " " 100
1 " " 24	2 " " 126
3 " " 35	



Model No. 45 Fire Escape

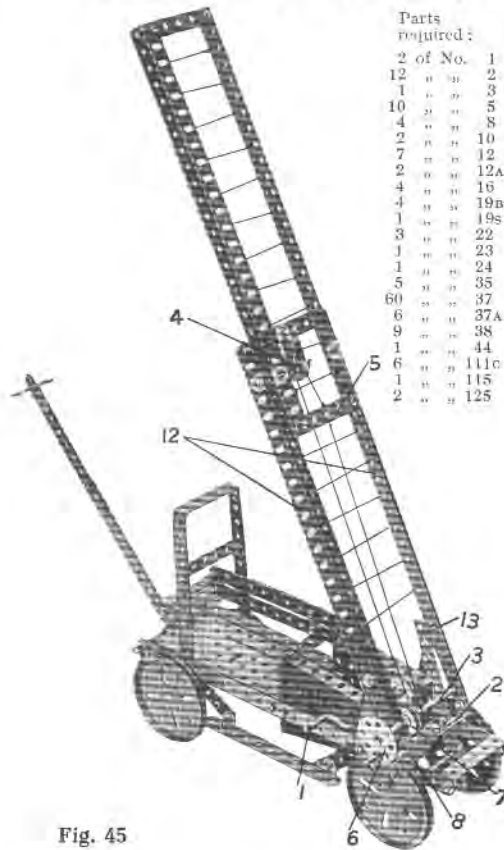

Parts required:

2 of No.	1
12 "	2
1 "	3
10 "	5
4 "	8
2 "	10
7 "	12
2 "	12A
4 "	16
4 "	19B
1 "	19S
3 "	22
J "	23
1 "	24
5 "	35
6 "	37
9 "	37A
1 "	38
6 "	44
1 "	111C
1 "	115
2 "	125

Fig. 45

The ladder is elevated on operation of the Crank Handle 1, which winds in a cord tied to the Double Angle Strip 2. Angle Brackets bolted to the 12 1/2" Angle Girders 12 are attached pivotally to the 5 1/2" Strips 13 by means of bolts and nuts (S.M. 262), and the action of winding in the cord thus causes the ladder to swing upward. It is prevented from falling by the friction of the 1" Pulley Wheels 10 (Fig. 45a), which press against the two Sector Plates. When the ladder is fully elevated, its lower ends act as brakes to prevent the road wheels from revolving.

A second cord is wound upon the Rod 3. One end is then carried over the 1/2" loose Pulley Wheel 4 and tied to the 2 1/2" Strip 5, the opposite end being carried directly to the same Strip 5, the opposite end being carried directly to the same Strip and secured to it. When the handle 6 is turned, the two ends of the cord are wound and unwound simultaneously, and the ladder is extended or shortened as required. A permanent brake is provided by a cord passing over the 1" Pulley Wheel 7 and having both its ends secured to the 2 1/2" Strip 8. The Strip 8 is bolted firmly to the Angle Bracket 9 (Fig. 45a) and keeps the brake continuously in action.

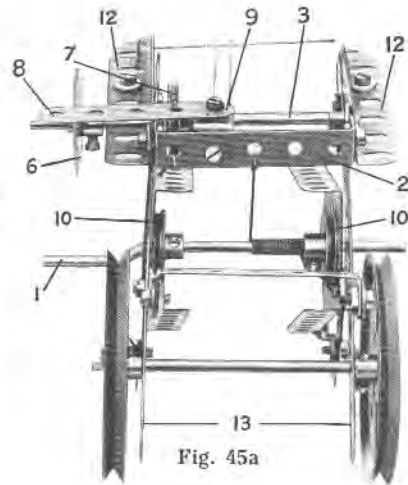
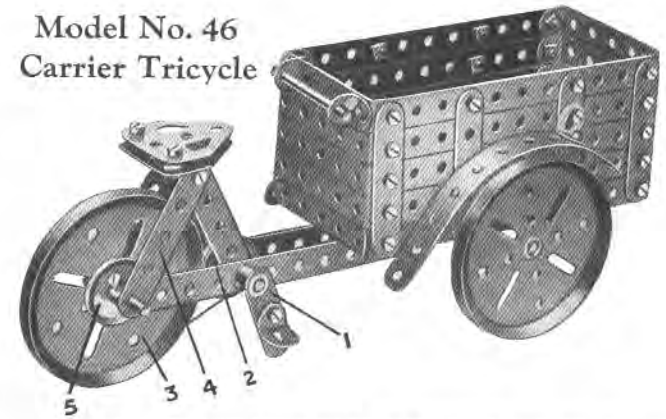

Fig. 45a

Model No. 46 Carrier Tricycle



Parts required:

12 of No.	2
2 "	5
2 "	11
6 "	12
1 "	16
1 "	17
2 "	18A
3 "	19B
2 "	22
15 "	37
6 "	37A
8 "	48A
1 "	52
1 "	62
2 "	90A
3 "	111C
2 "	126

Each pedal of the tricycle consists of an Angle Bracket pivotally attached to a Crank 1 by means of a bolt and two nuts (see S.M. No. 262). The Cranks are secured to a 1 1/2" Axle Rod carrying a 1" fast Pulley Wheel 2. A cord passes round this Pulley and around the 3" Pulley Wheel 3, which is spaced away from the 2 1/2" Strips 4 by a 1" fast Pulley Wheel 5. The Double Bracket 6 (Fig. 46a) is attached pivotally to the lower framework by a bolt and lock-nuts (S.M. 263).

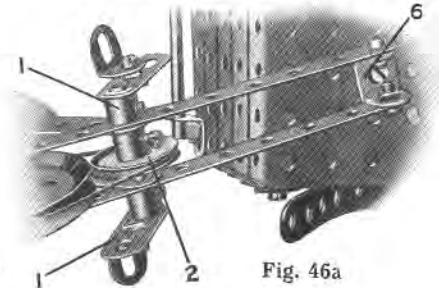

Fig. 46a

Model No. 47 Derrick

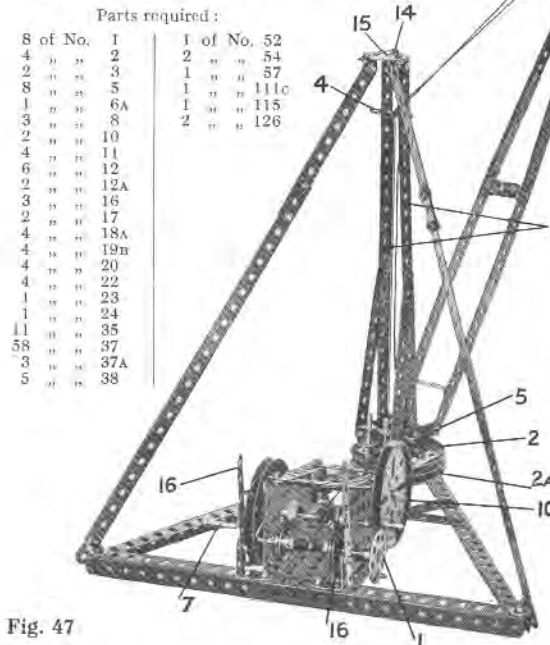

Fig. 47

Parts required:

8 of No.	1	1 of No.	52
4 "	2	2 "	54
2 "	3	1 "	57
8 "	5	1 "	111C
1 "	6A	1 "	115
3 "	8	2 "	126
2 "	10		
4 "	11		
6 "	12		
2 "	12A		
3 "	16		
4 "	17		
4 "	18A		
4 "	19B		
4 "	20		
4 "	22		
1 "	23		
1 "	24		
11 "	35		
58 "	37		
3 "	37A		
5 "	38		

Model No. 47—Instructions

The 3" Pulley Wheel 2, which supports the jib, is free to turn on a short Axle Rod secured in the boss of the lower 3" Pulley Wheel 2a. The vertical 12 1/2" Strips 13 are bolted at their tops to a Double Bracket, to the centre hole of which is secured a bolt 14 that is free to turn in the Flat Trunnion 15.

The swivelling movement of the crane is carried out by turning the handle 1, which simultaneously winds and unwinds the ends of a cord passing round the 3" Pulley Wheel 2 (see Fig. 47a). The cord 12, which is tied to the Flat Bracket 3 at the head of the jib, passes over the 2" Rod 4, under a similar Rod 5, and between two vertical 2" Rods 6, which act as guides, and is finally wound on to the Crank Handle 7. Hence on operation of the latter the jib is raised or lowered. The cord 8 also passes round the Rods 4, 5, and 6, and is wound on to the Rod 9. Operation of the handle 10 raises and lowers the Hook. The cords 8 and 12 are prevented from unwinding by band-and-pulley brakes 16.

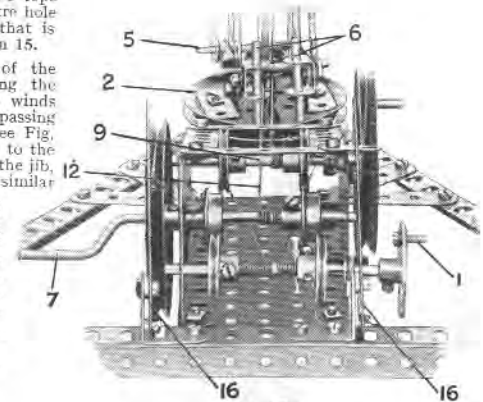

Fig. 47a



### Model No. 48 Travelling Jib Crane

The swivelling structure is bolted to the 3" Pulley Wheel 1, which rests on a second 3" Pulley bolted to the travelling base. A short Rod secured in the boss of the upper Pulley is free to rotate in the boss of the lower one. The Electric Motor 2 controls the hoisting gear and the arrangement of the drive will be clear from the photograph. The jib is luffed on operation of the Crank Handle 3, the cord of which passes round the Axle Rod 4 in the jib, then round the Rod 5 in the base, back round the Rod 4 and is finally secured to a Flat Bracket on the Rod 5.

Parts required:	
10 of No. 1	14 of No. 35
9 " " 2	60 " " 37
2 " " 3	6 " " 37A
2 " " 5	14 " " 38
2 " " 6A	1 " " 48
4 " " 8	7 " " 48A
1 " " 10	1 " " 52
1 " " 11	1 " " 57
2 " " 12	
2 " " 15	
1 " " 15A	
1 " " 16	
1 " " 17	
2 " " 18A	
1 " " 19	
4 " " 19B	
4 " " 20	
4 " " 22	
1 " " 23	
1 " " 24	

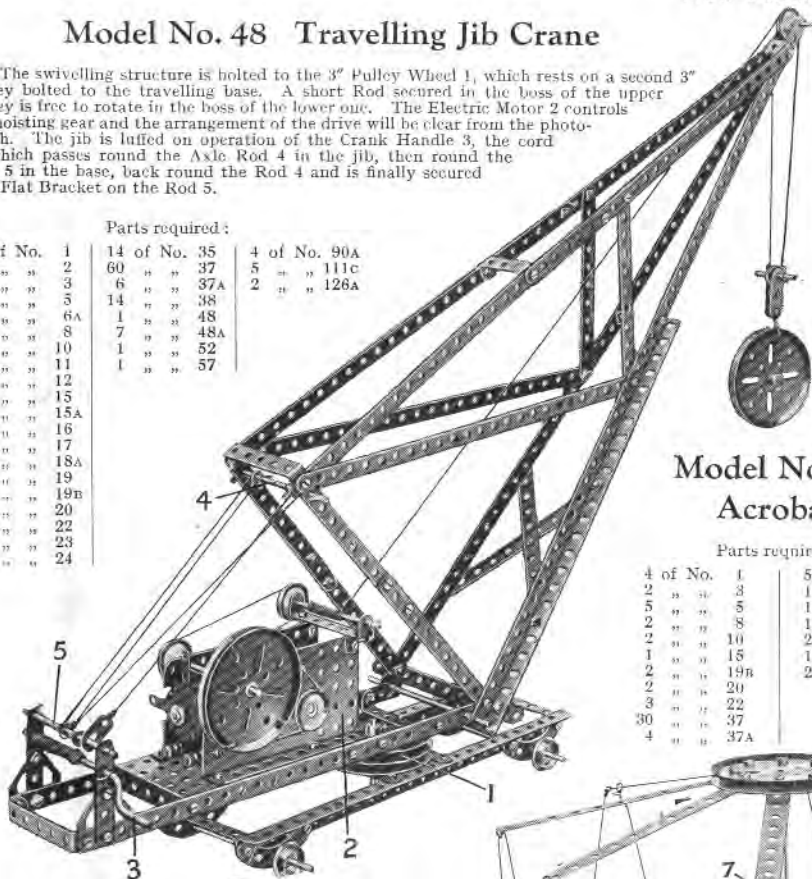

### Model No. 49 Acrobat

Parts required:	
4 of No. 1	5 of No. 38
2 " " 3	1 " " 45
5 " " 5	1 " " 52
2 " " 8	1 " " 54
10 " " 10	2 " " 62
2 " " 15	1 " " 115
1 " " 19B	2 " " 126
2 " " 20	
3 " " 22	
30 " " 37	
4 " " 37A	

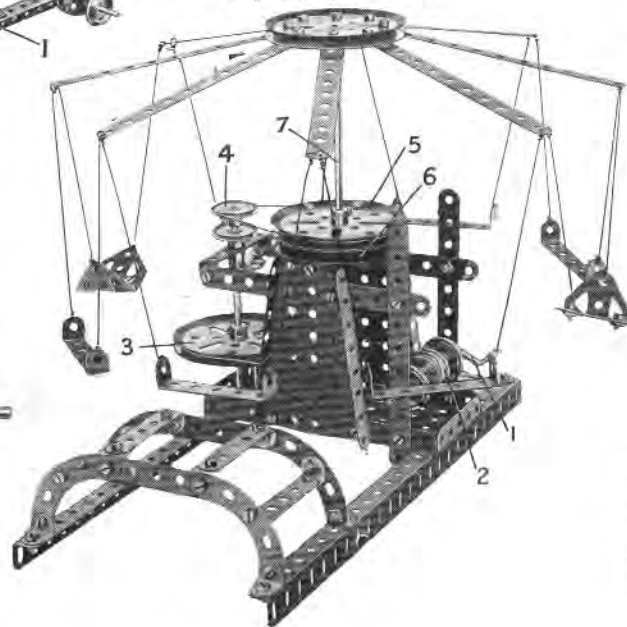
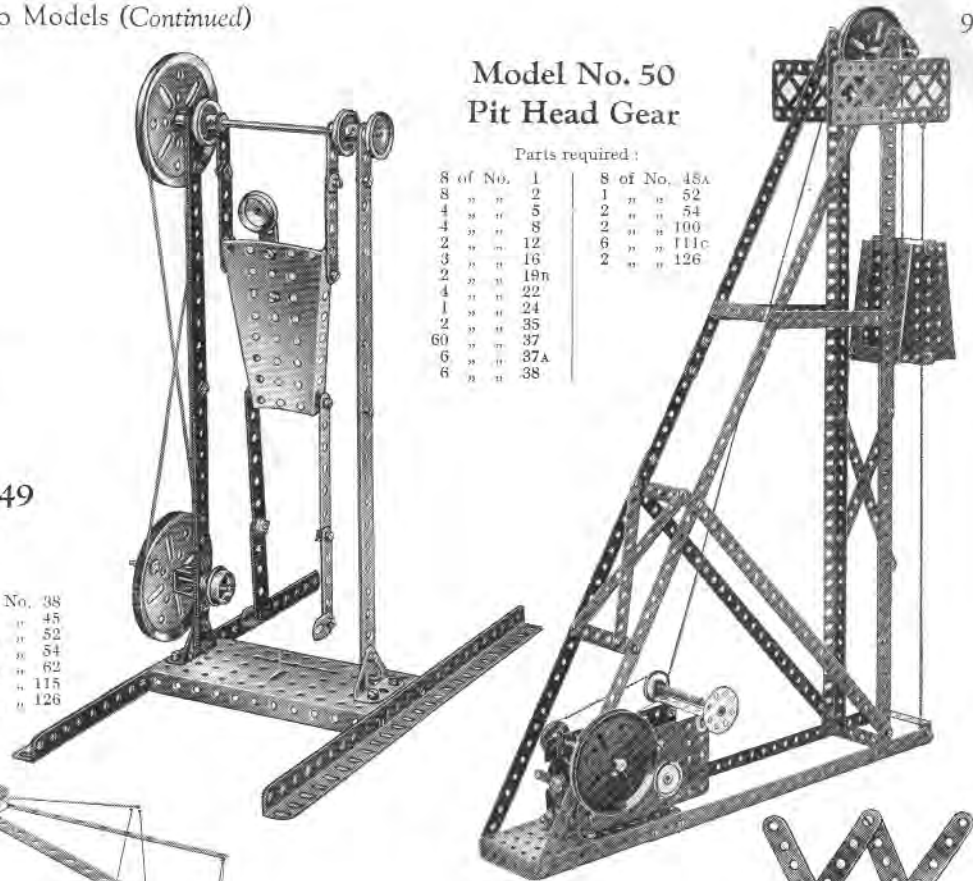

Fig. 51a

### Model No. 50 Pit Head Gear

Parts required:	
8 of No. 1	8 of No. 48A
8 " " 2	1 " " 52
4 " " 5	2 " " 54
4 " " 8	2 " " 100
2 " " 12	6 " " 111c
3 " " 16	2 " " 126
2 " " 19B	
4 " " 22	
1 " " 24	
2 " " 35	
60 " " 37	
6 " " 37A	
6 " " 38	



### Model No. 51 Roundabout

Parts required:	
13 of No. 2	4 of No. 22
6 " " 5	1 " " 24
2 " " 8	48 " " 37
12 " " 12	7 " " 48A
2 " " 12A	1 " " 52
2 " " 15	2 " " 54
1 " " 19	4 " " 90A
4 " " 19B	2 " " 126
2 " " 20	2 " " 126A

When the Crank Handle 1 is turned, the drum 2 (formed by butting together two 3" Flanged Wheels) turns the 3" Pulley Wheel 3 by means of an endless cord. The 1" fast Pulley Wheel 4 similarly turns a second 3" Pulley Wheel 5 resting on another 3" Pulley Wheel 6 (see Fig. 51a). The end of the Axle Rod 7 is quite free to revolve in the boss of the lower 3" Pulley Wheel 6.

### Model No. 52 Music Stand

Parts required:	
1 of No. 2	
8 " " 5	
3 " " 12	
12 " " 37	
2 " " 48A	
1 " " 126	

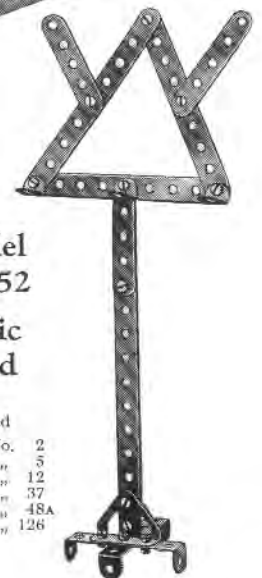

Model No. 53 Steam Wagon

Parts required :	
14 of No. 2	4 of No. 19a
6 " " 3	3 " " 20
6 " " 5	1 " " 21
2 " " 6A	4 " " 22
6 " " 8	1 " " 23
8 " " 10	1 " " 24
3 " " 11	1 " " 26
19 " " 12	79 " " 37
2 " " 12A	10 " " 38
1 " " 15	2 " " 48b
3 " " 16	2 " " 52
2 " " 18A	3 " " 53

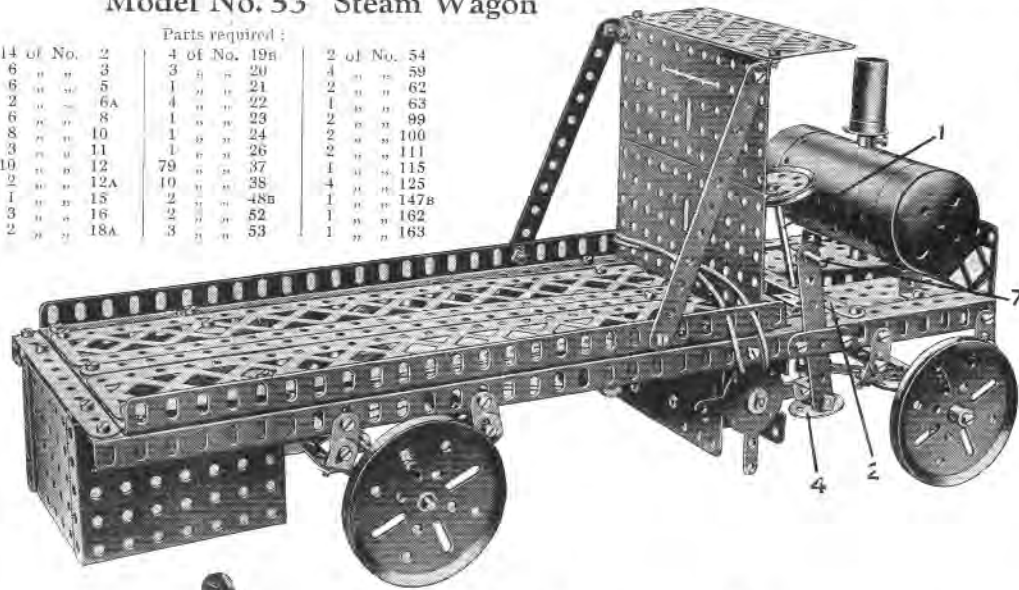

The steering column 1 is journaled in bearings consisting of a 5 1/4" Strip 2 and two 2 1/2" Strips 3 (Fig. 53a), and carries the Bush Wheel 4, which is secured rigidly to it. A 3/4" Flanged Wheel 5 supports the weight of the steering column 1. The stub axles of the front road wheels consist of 3/8" Bolts, on which the road wheels are spaced by Washers 14. These bolts serve in the place of set-screws to secure two Collars to the 1" Rods 8. A pair of Cranks 9, 9a secured to the Rods 8 are joined by two 5 1/2" Strips 15 overlapped eight holes. A 1 1/2" Strip 10, bolted to the face of the Bush Wheel 4, is connected pivotally by a composite 4 1/2" Strip 11 (a 3 1/2" Strip and a 2 1/2" Strip overlapped three holes) to the end of the Crank 9. When the steering wheel is turned, the Strip 11 moves the Cranks 9, 9a, thereby deflecting the front road wheels.

The Electric Motor 6 is controlled by raising and depressing the handle 7. Duplicate drive transmission belts 12 and 13 are used in order to secure a more dependable drive to the rear axle.

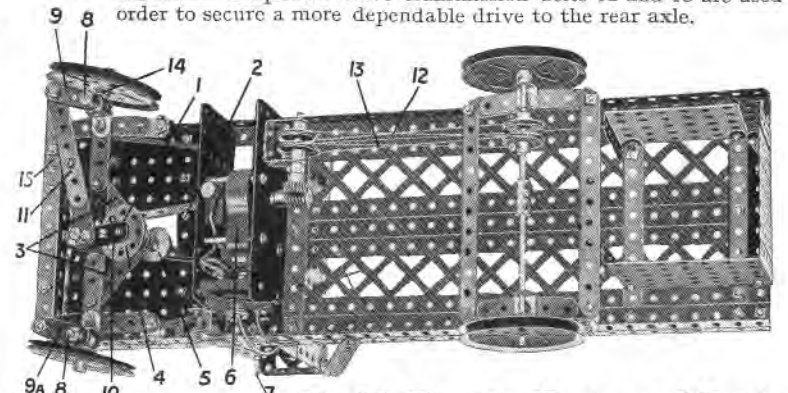
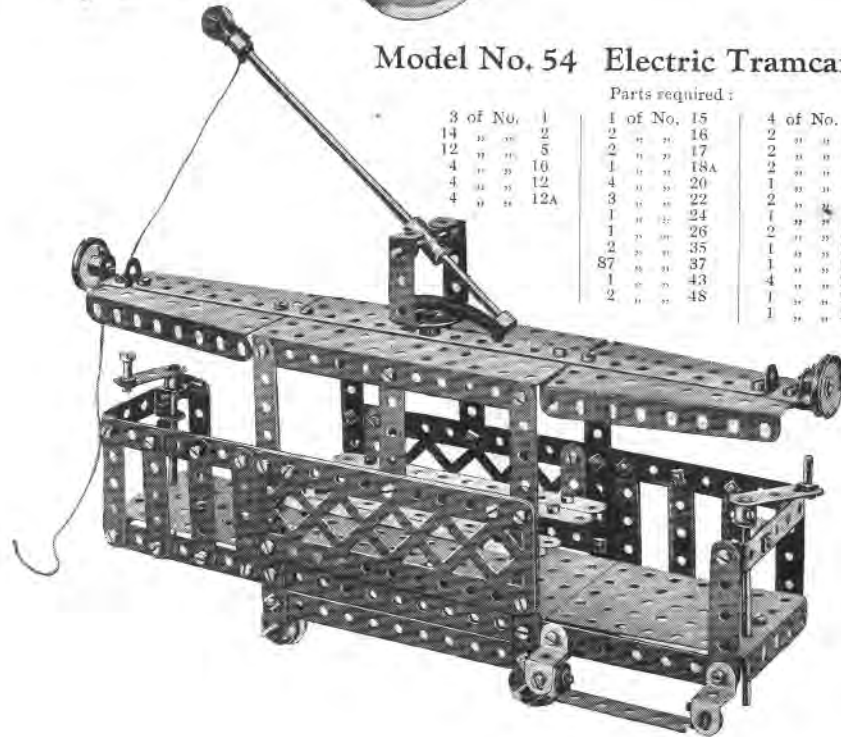

Fig. 53a

Model No. 54 Electric Tramcar

Parts required :		
3 of No. 1	1 of No. 15	4 of No. 48A
14 " " 2	2 " " 16	2 " " 52
12 " " 5	2 " " 17	2 " " 54
4 " " 10	1 " " 18A	2 " " 54
4 " " 12	4 " " 20	1 " " 59
4 " " 12A	3 " " 22	2 " " 62
	1 " " 24	1 " " 63
	1 " " 26	2 " " 100
	2 " " 35	1 " " 111c
	87 " " 37	1 " " 115
	1 " " 43	4 " " 125
	2 " " 48	1 " " 116A
		1 " " 147B



Model No. 55 Horizontal Engine

This model forms an interesting example of the use of the Meccano Boiler, Sleeve Piece and other new parts. The 2 1/2" Strip 1, forming the connecting rod, is attached to the 1 1/2" Pulley Wheel by means of a Threaded Pin. The latter is fastened in one hole of the 1 1/2" Pulley Wheel, and two Washers are placed upon it between the Strip 1 and the Wheel. The connecting rod is held in place by a Collar locked to the end of the Threaded Pin.

The boiler is attached to the framework by means of two 2 1/2" x 1/2" Double Angle Strips attached by their centre holes to the side of the boiler opposite the chimney. When the boiler is placed in the position shown, the whole is secured by bolting the Double Angle Strips to the side Flanged Plates.

Parts required :	
5 of No. 5	1 of No. 48
2 " " 8	3 " " 48A
2 " " 12	2 " " 48B
3 " " 15	2 " " 52
1 " " 19	3 " " 53
2 " " 19b	3 " " 59
4 " " 20	1 " " 116
1 " " 21	2 " " 126
1 " " 22	1 " " 162
2 " " 35	1 " " 163
37 " " 37	1 " " 165

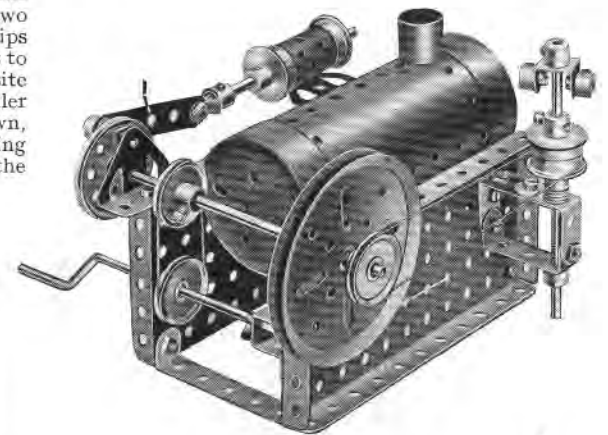



### Model No. 56 Paddle Boat

Parts required:

6 of No. 1	1 of No. 24	1 of No. 59
4 " " 2	1 " " 27A	2 " " 62
6 " " 3	4 " " 35	1 " " 63
2 " " 4	94 " " 37	2 " " 99
10 " " 5	3 " " 37A	2 " " 100
2 " " 6A	3 " " 38	1 " " 111
14 " " 12	2 " " 45	1 " " 116A
2 " " 15	1 " " 46	1 " " 126A
2 " " 15A	10 " " 48	1 " " 138A
4 " " 16	10 " " 48A	2 " " 52
2 " " 18A	2 " " 53	1 " " 166
4 " " 19B		
4 " " 20		
4 " " 22		

Why not join the Meccano Guild and keep in touch with your fellow Meccano boys? Write to the Secretary, Meccano Guild Headquarters, Binns Road, Liverpool, for particulars and rules of membership.

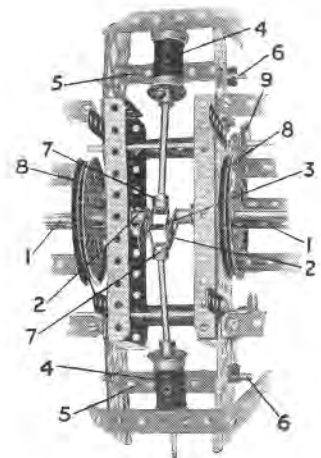
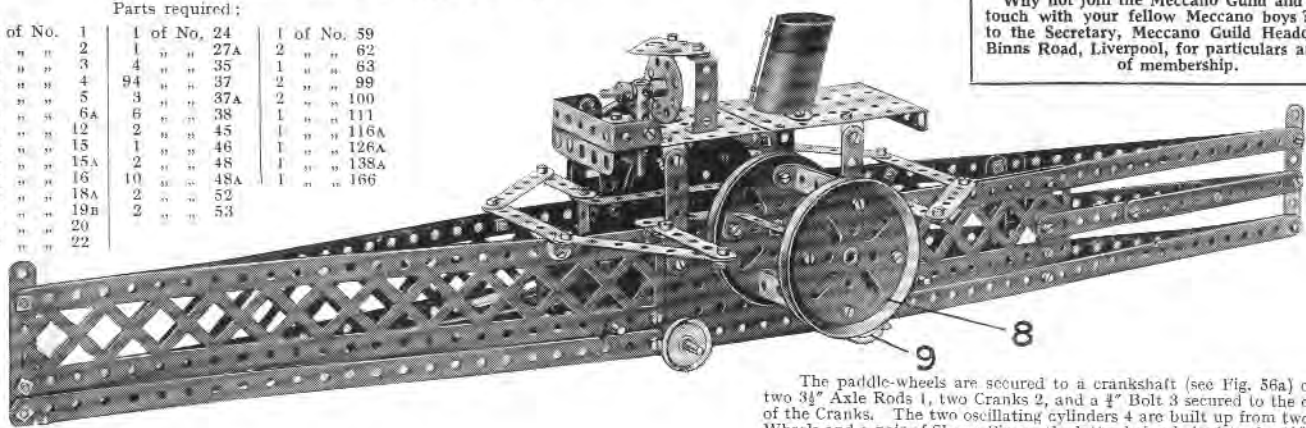

Fig. 56a

The paddle-wheels are secured to a crankshaft (see Fig. 56a) consisting of two 3/4" Axle Rods 1, two Cranks 2, and a 1/2" Bolt 3 secured to the central holes of the Cranks. The two oscillating cylinders 4 are built up from two 3/4" Flanged Wheels and a pair of Sleeve Pieces, the latter being bolted to the 2 1/2" x 1/4" Double Angle Strips 5, which are free to turn on Rods 6. The ends of the 5" Piston Rods are secured in the bosses of two small Fork Pieces 7, which pivot about the 1/2" Bolt 3 of the crankshaft. As the model runs along the ground, the 3" Pulley Wheels 8 secured to the rods 1 are rotated by endless cords from the 1" fast Pulley Wheels 9, while the cylinders 4 oscillate and appear to be actually operating the paddle-wheels.

### Model No. 57 Tower Wagon

When operated the handle 1 winds in the cord 2, which passes over a 1" fast Pulley Wheel 3 and is tied to the Rod 4. The upper part of the tower is thus raised or lowered as required, being guided by the 3/4" Flanged Wheels 5 and two pairs of Reversed Angle Brackets 6. The steering cords 7 are tied to the 57-teeth Gear Wheel 8 and to the end of a 2 1/4" x 1/4" Double Angle Strip bolted to a Double Bent Strip, which is pivoted to the Sector Plate 9. The front axle is journalled through the ends of the Double Angle Strip.

Parts required:

4 of No. 1
2 " " 4
6 " " 5
2 " " 6A
8 " " 8
8 " " 12
1 " " 15
3 " " 15A
4 " " 16
1 " " 17
4 " " 19B

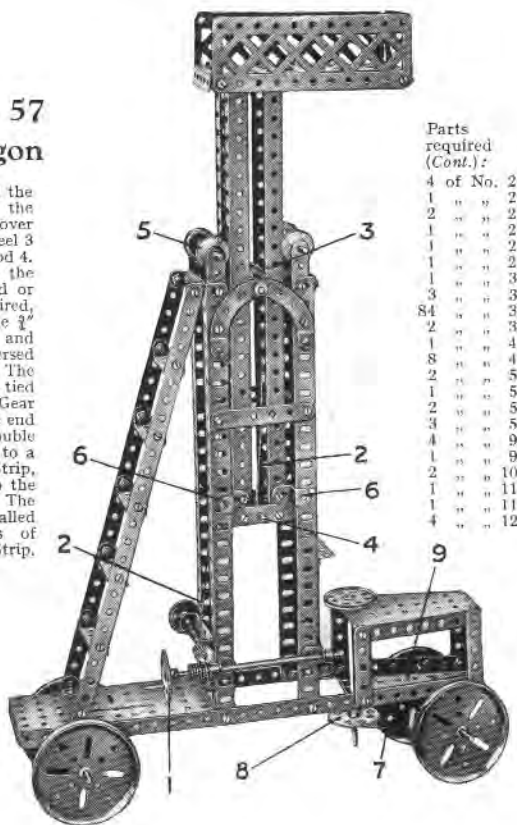

Parts required (Cont.):

4 of No. 20	21
1 " " 22	22
1 " " 24	24
1 " " 26	26
1 " " 27A	27A
1 " " 32	32
3 " " 35	35
84 " " 37	37
2 " " 37A	37A
1 " " 45	45
8 " " 48A	48A
2 " " 52	52
1 " " 53	53
2 " " 54	54
3 " " 59	59
4 " " 90A	90A
1 " " 98	98
2 " " 100	100
1 " " 111C	111C
1 " " 115	115
4 " " 125	125

### Model No. 58 Railway Breakdown Crane

The pivotal arm 1 consists of a 5" Rod, to the ends of which are secured a small and a large Fork Piece, the latter being pivoted to the Double Bracket 2 by means of a 1/2" Bolt. The hoisting cord attached to the Hook 3 passes under a 3 1/2" Rod 4 and is wound on a Crank Handle 5. The cord 6, which raises the jib, is operated by a second Crank Handle 7. It passes over the 1" loose Pulley Wheel 8, round the 1/2" loose Pulley 9 (which is mounted on a Pivot Bolt), and is then led back again and tied to a Flat Bracket on the 1 1/4" Rod that carries the Pulley 8. Each Crank Handle 5, 7 is provided with a permanent band-and-pulley brake to prevent the jib from falling when the handles are released. The method of rotating the crane will be clear from the illustration.

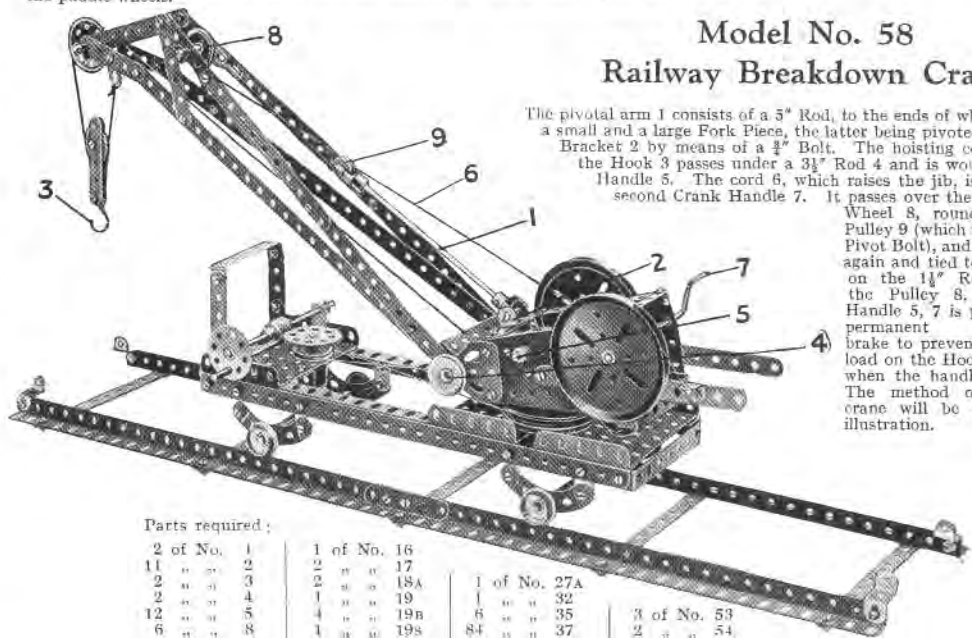

Parts required:

2 of No. 1	1 of No. 16
11 " " 2	2 " " 17
2 " " 3	2 " " 18A
2 " " 4	1 " " 19
12 " " 5	4 " " 19B
6 " " 8	1 " " 19S
2 " " 10	4 " " 20
2 " " 11	1 " " 21
3 " " 12	4 " " 22
2 " " 12A	2 " " 22A
1 " " 15	1 " " 23
3 " " 15A	1 " " 24

1 of No. 27A	3 of No. 53	1 of No. 116
1 " " 32	2 " " 54	1 " " 116A
6 " " 35	1 " " 57	4 " " 125
84 " " 37	3 " " 59	2 " " 126A
1 " " 37A	4 " " 90A	1 " " 147B
1 " " 45		
1 " " 46		
3 " " 48A		
2 " " 48B		

**Model No. 59 Pile Driver**

On moving the hand lever 6 to the right a  $\frac{1}{2}$ " Pinion on the hoisting shaft is brought into engagement with the 57-teeth Gear Wheel 1 on the driving shaft and the ram 4 is raised. The hoisting cord 2 is tied to an Angle Bracket 3, which lodges under another Angle Bracket 3, which lodges under another Angle Bracket bolted to the ram. The latter may be dropped whenever required by jerking the cord 5, thereby releasing the Brackets 3. The Strips 7 are duplicated, and the Girders 8 slide between their ends.

Parts required:		Parts required:	
6 of No. 1	3 of No. 16	60 of No. 37	1 of No. 111c
3 " " 2	1 " " 19b	1 " " 38	1 " " 115
2 " " 3	3 " " 20	2 " " 45	2 " " 126
6 " " 5	1 " " 21	1 " " 46	2 " " 126A
2 " " 6A	2 " " 22	1 " " 48A	
7 " " 8	2 " " 26	1 " " 48B	
8 " " 12	1 " " 27A	2 " " 52	
1 " " 15A	1 " " 32	2 " " 53	
	2 " " 35	4 " " 59	
	2 " " 37A	1 " " 90A	
	1 " " 38	1 " " 115	
	1 " " 45	2 " " 126	
	1 " " 46	2 " " 126A	
	1 " " 48A		
	2 " " 48B		
	2 " " 52		
	2 " " 53		
	4 " " 59		
	1 " " 90A		
	1 " " 111c		
	1 " " 115		
	2 " " 126		
	2 " " 126A		

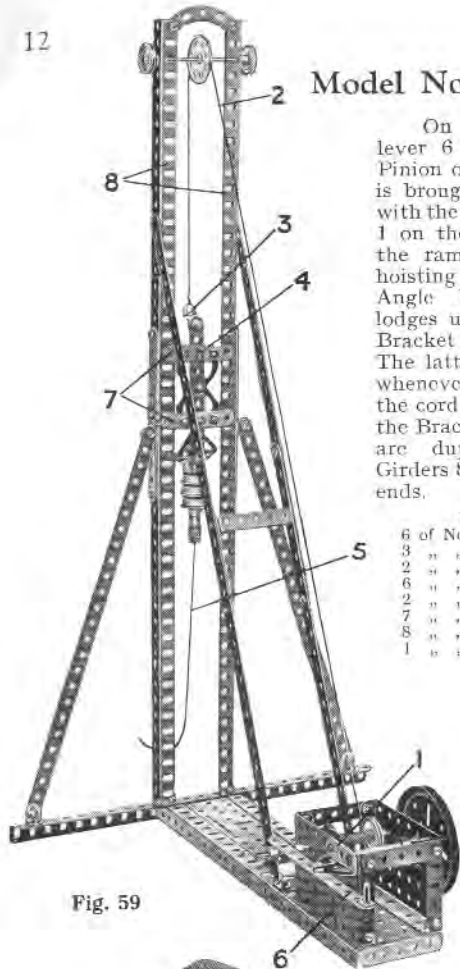

Fig. 59

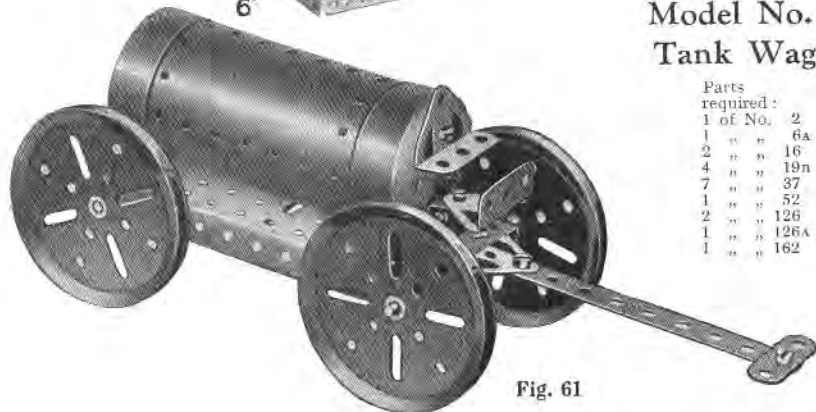

Fig. 61

**Model No. 61 Tank Wagon**

Parts required:	
1 of No. 2	
1 " " 6A	
2 " " 16	
4 " " 19n	
7 " " 37	
1 " " 52	
2 " " 126	
1 " " 126A	
1 " " 162	

**Model No. 60 Tank Lorry**

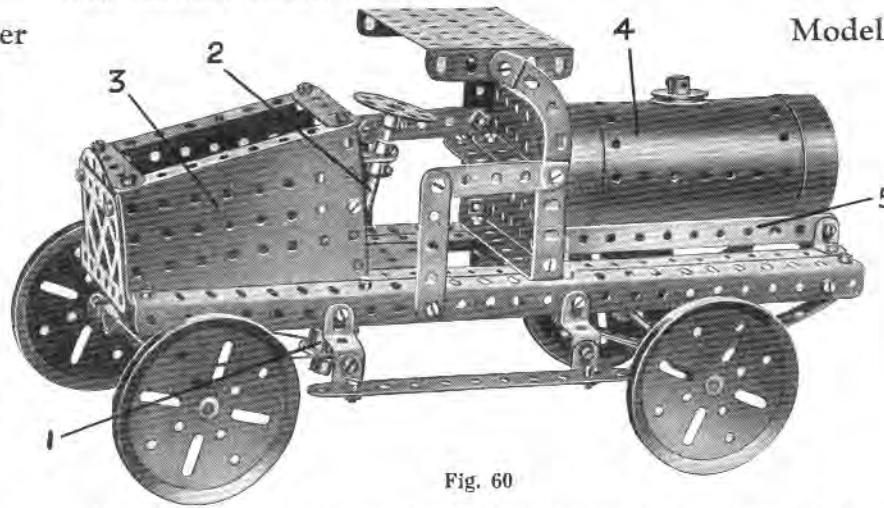

Fig. 60

Parts required:

Parts required:		Parts required:	
2 of No. 1	75 of No. 37	3 " " 37A	
7 " " 2	3 " " 38	4 " " 48	
6 " " 3	1 " " 48A	1 " " 48B	
10 " " 5	1 " " 52	2 " " 53	
1 " " 6A	1 " " 54	2 " " 59	
2 " " 8	1 " " 90A	3 " " 98	
2 " " 11	1 " " 111c	2 " " 125	
12 " " 12	4 " " 126	2 " " 162	
2 " " 12A			
2 " " 15			
1 " " 15A			
4 " " 19b			
2 " " 20			
1 " " 19b			
1 " " 22			
1 " " 24			
4 " " 35			

It should be noted that the steering cord is given a complete turn around the two  $\frac{3}{4}$ " Flanged Wheels 1 to prevent slipping. The steering column 2 is journalled in the end of a  $1\frac{1}{2}$ " Strip, the other end of which is bolted to a  $2\frac{1}{2}$ " x  $\frac{1}{2}$ " Double Angle Strip secured between the two Sector Plates 3. The front road wheels are secured to a 5" Rod that is journalled in the end holes of a  $3\frac{1}{2}$ " x  $\frac{1}{2}$ " Double Angle Strip. The ends of the steering cord are tied to this strip, which is pivoted by means of a bolt and lock-nuts (S.M. 263) to the central hole of a  $1\frac{1}{2}$ " x  $\frac{1}{2}$ " Double Angle Strip. The latter is bolted between a pair of Trunnions attached to the underside of the  $5\frac{1}{2}$ " x  $2\frac{1}{2}$ " Flanged Plate. The tank 4 merely rests on the  $5\frac{1}{2}$ " Strips 5.

The "Meccano Magazine" contains all-important news for Meccano boys, such as particulars of new parts, descriptions of new models, and criticisms of entries in the Model-building Competitions, as well as announcements of new contests. The "M.M." appears on the first of every month (see page 4 of cover of this Manual).

**Model No. 62 Steam Road Roller**

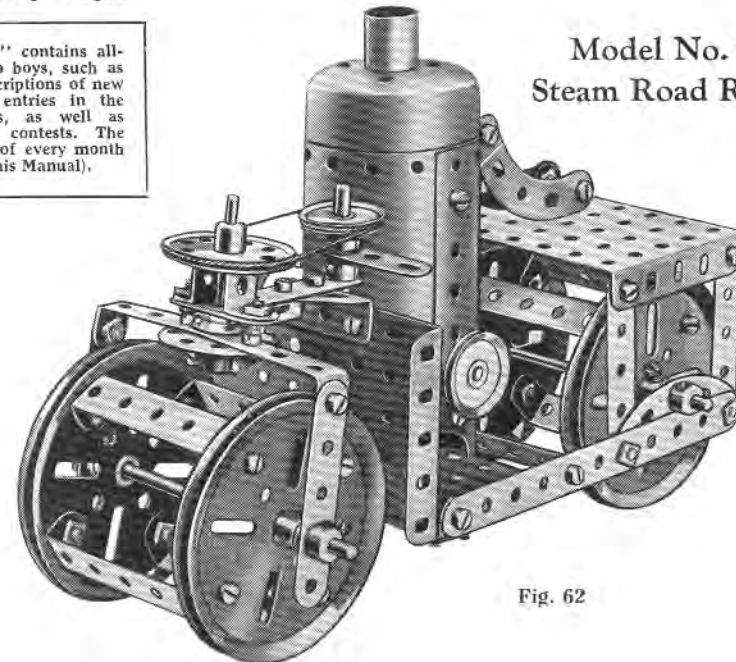

Fig. 62

Parts required:	
2 of No. 2	5
7 " " 5	11
2 " " 11	12
1 " " 12	12A
2 " " 16	16
3 " " 17	19b
1 " " 21	21
4 " " 19b	22
1 " " 23	23
1 " " 24	37
57 " " 37	38
11 " " 45	48A
1 " " 48B	48B
3 " " 53	53
4 " " 59	59
1 " " 62	62
4 " " 90A	90A
1 " " 126	126
1 " " 126A	126A
1 " " 162	162
1 " " 164	164



### Model No. 63 Submarine

This model represents a large submarine of the latest type. It is equipped with wireless mast, periscope, quick-firing gun, and a workable steering gear controlled from the conning-tower.

Figure 63a is a sectional view of the conning-tower, and shows the helm. The cord 1, after passing over the 1" fast Pulley 7, is carried round a pair of 1" loose Pulley Wheels on the 5" Rod 2 (Fig. 63), and is given a complete turn round the 1" fixed Pulley Wheel 3 secured to the rudder head. The rudder consists of two 2½" Flat Girders, which are bolted by means of Angle Brackets to a pair of Cranks mounted on the Rod 4. The short Rod carrying the Pulley 7 is journalled in a 2½" x ½" Double Angle Strip 8, and is held in place by a Collar and set-screw on its end. Washers should be placed between the Pulley 7 and Strip 8.

The 5½" x 2½" Flanged Plates that form the deck of the submarine are bolted together by means of 5½" Angle Girders, which, in turn, are bolted to 3½" x ½" Double Angle Strips secured transversely in the hull of the vessel. The hull itself is strengthened by vertical 3" Strips 5. The sides of the conning-tower are represented by two 3½" x 2½" Flanged Plates, the forward part being composed of a 2½" small radius Curved Strip and five 2½" x ½" Double Angle Strips. The periscope consists of a Coupling and a 5" Rod, which is supported in a further 2½" x ½" Double Angle Strip 6.

The vertical Rod supporting the quick-firing gun is free to turn in a Bush Wheel bolted to the deck. Two Collars should be placed on the Rod, one on each side of the Bush Wheel, to maintain the gun in position. The model is arranged to travel on two pairs of ¾" Flanged Wheels secured to 3½" Axle Rods.

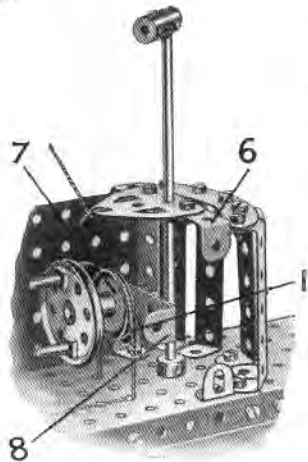
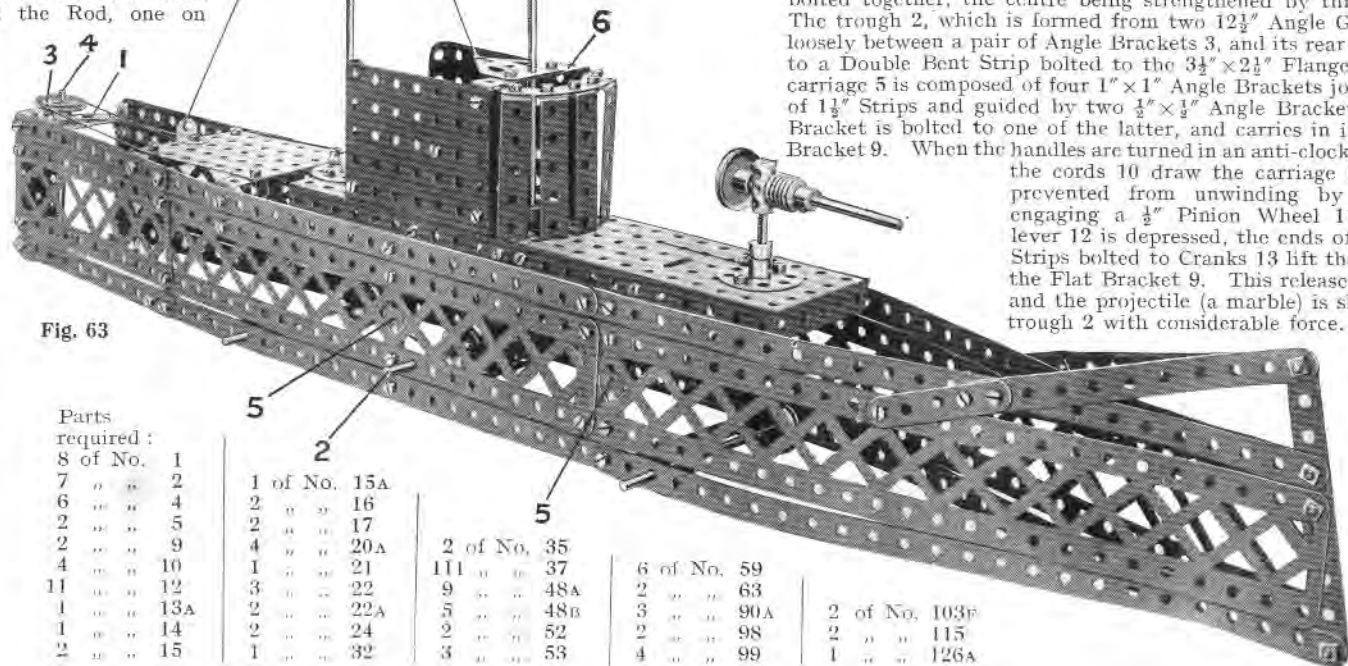

Fig. 63a

Fig. 63

Parts required:	
8 of No.	1
7 " "	2
6 " "	4
2 " "	5
2 " "	9
4 " "	10
11 " "	12
1 " "	13A
1 " "	14
2 " "	15

Parts required:			
6 of No.	1	1 of No.	15
7 " "	5	3 " "	15A
2 " "	6A	4 " "	16
4 " "	8	4 " "	17
2 " "	9	2 " "	19B
1 " "	10	4 " "	22
1 " "	11	2 " "	24
4 " "	12	1 " "	26
4 " "	12A		



1 of No.	15A
2 " "	16
2 " "	17
4 " "	20A
1 " "	21
3 " "	22
2 " "	22A
2 " "	24
1 " "	32

2 of No.	35
111 " "	37
9 " "	48A
5 " "	48B
2 " "	52
3 " "	53

6 of No.	59
2 " "	63
3 " "	90A
2 " "	98
4 " "	99

2 of No.	103F
2 " "	115
1 " "	126A

Parts required (Cont.):			
53 of No.	37	4 of No.	59
2 " "	37A	2 " "	62
5 " "	38	3 " "	63
1 " "	45	2 " "	108
1 " "	48	2 " "	111
1 " "	48B	1 " "	115
3 " "	53	2 " "	126
		1 " "	126A
		1 " "	147A
		1 " "	147B

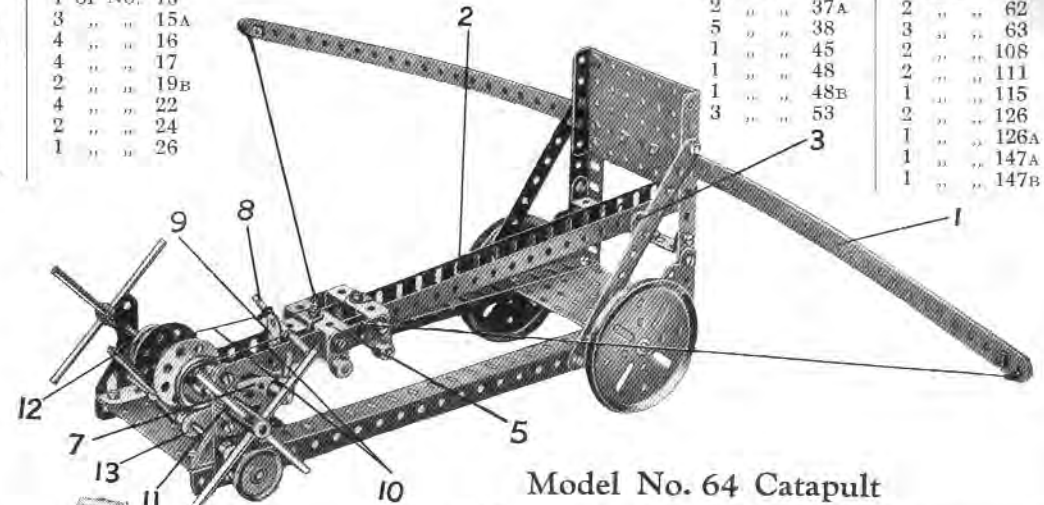

### Model No. 64 Catapult

This model represents a large military weapon of the type used before the invention of gunpowder. It is built on the principle of the crossbow. Each side of the bow 1 is composed of three 12½" Strips bolted together, the centre being strengthened by three 2½" Strips. The trough 2, which is formed from two 12½" Angle Girders, is held loosely between a pair of Angle Brackets 3, and its rear end is secured to a Double Bent Strip bolted to the 3½" x 2½" Flanged Plate. The carriage 5 is composed of four 1" x 1" Angle Brackets joined by a pair of 1½" Strips and guided by two ½" x ½" Angle Brackets. A Double Bracket is bolted to one of the latter, and carries in its turn a Flat Bracket 9. When the handles are turned in an anti-clockwise direction, the cords 10 draw the carriage back, and are prevented from unwinding by the Pawl 7 engaging a ½" Pinion Wheel 11. When the lever 12 is depressed, the ends of a pair of 2½" Strips bolted to Cranks 13 lift the 2" Rod 8 off the Flat Bracket 9. This releases the carriage, and the projectile (a marble) is shot out of the trough 2 with considerable force.

Model No. 65 Tipping Motor Lorry

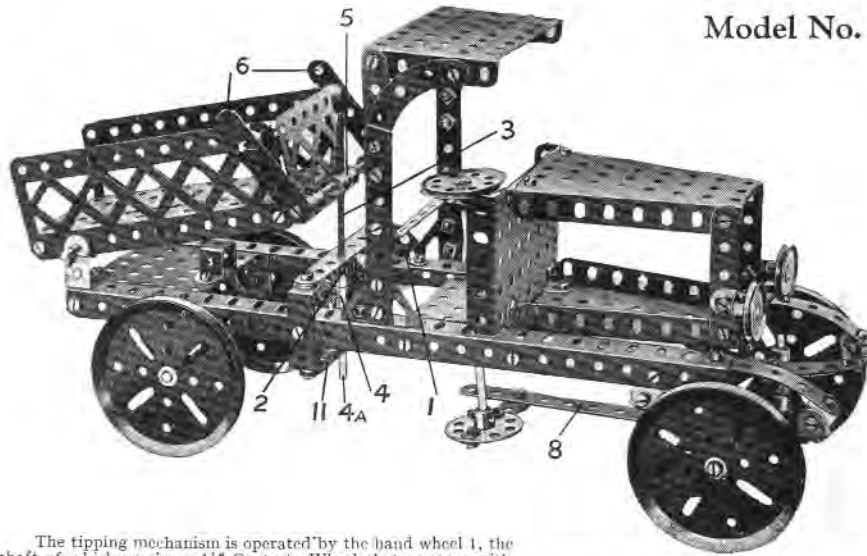

Parts required :

2 of No. 2	4 of No. 37A
2 " " 2A	14 " " 38
6 " " 3	2 " " 45
12 " " 5	2 " " 48
2 " " 6A	1 " " 48B
5 " " 8	1 " " 52
2 " " 10	2 " " 53
15 " " 12	2 " " 54
2 " " 12A	10 " " 59
4 " " 15A	2 " " 62
1 " " 17	4 " " 63
5 " " 18A	1 " " 80A
4 " " 19m	2 " " 90A
1 " " 21	1 " " 98
2 " " 22	2 " " 100
1 " " 24	4 " " 111c
1 " " 26	1 " " 115
1 " " 28	2 " " 125
8 " " 35	2 " " 126
89 " " 37	2 " " 126A

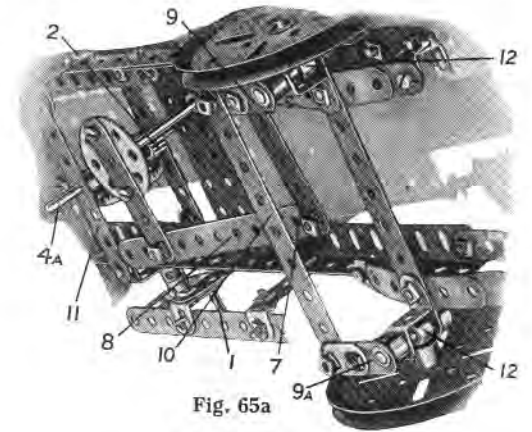
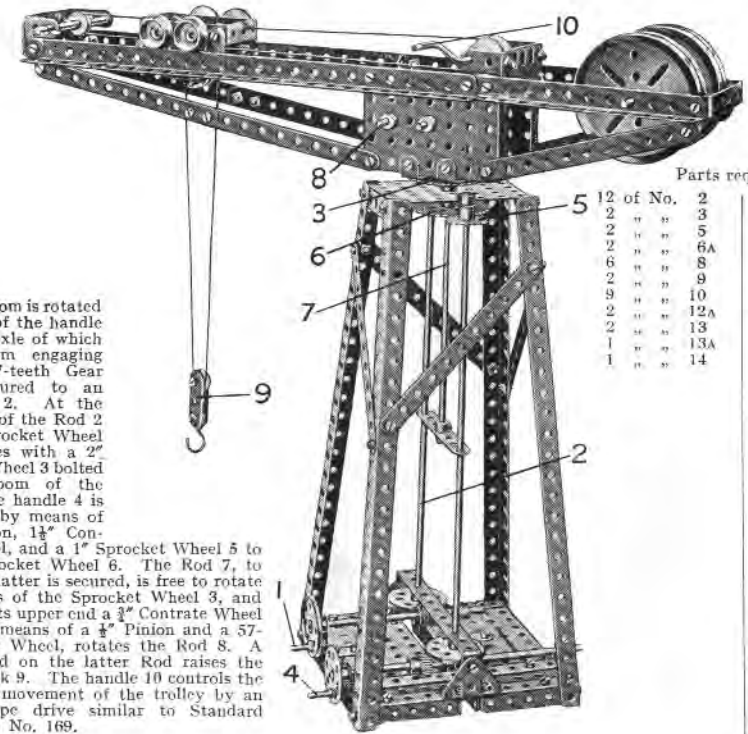

Fig. 65a

The tipping mechanism is operated by the hand wheel 1, the shaft of which carries a  $1\frac{1}{2}$ " Contrate Wheel that engages with the  $\frac{1}{2}$ " Pinion 2. The  $3\frac{1}{2}$ " Threaded Rod 3, to which the Pinion 2 is secured, is journaled in one end of a Coupling 4 and passes through the central threaded bore of a second Coupling 5, which is mounted between the ends of two short Rods that are free to turn on bolts passed through  $2\frac{1}{2}$ " Strips 6. These Strips 6 are attached pivotally to the body of the lorry. The short Rod 4a passes through the  $3\frac{1}{2}$ " Strip 11 and is secured in the lower end of the Coupling 4, the centre transverse hole of which forms a bearing for the Rod of the hand wheel 1.

The steering gear is shown in Fig. 65a. The  $2\frac{1}{2}$ " Strip 7 is pivoted to the Strip 8, but is secured rigidly at right angles to the Crank 9. The Crank 9a is made to move simultaneously with the Crank 9 by means of the tie-rod 10. The front road wheels are mounted on  $\frac{1}{2}$ " Bolts secured in Collars 12.

Model No. 67 Girder Crane



Parts required :

12 of No. 2	1 of No. 15A
2 " " 3	4 " " 16
2 " " 5	3 " " 17
2 " " 6A	1 " " 19
6 " " 8	4 " " 19m
2 " " 9	6 " " 20
2 " " 10	1 " " 21
2 " " 12A	3 " " 22
2 " " 13	2 " " 23
2 " " 13A	2 " " 24
1 " " 14	2 " " 26
	2 " " 27A
	1 " " 28
	1 " " 29
	1 " " 32
	8 " " 35
	76 " " 37
	5 " " 37A
	2 " " 38
	2 " " 46
	2 " " 48
	4 " " 48A
	2 " " 48D
	2 " " 52
	3 " " 53
	1 " " 57
	9 " " 59
	2 " " 90A
	2 " " 95
	2 " " 96
	2 " " 103+
	4 " " 111c
	2 " " 115
	2 " " 126

The boom is rotated by means of the handle 1, on the axle of which is a Worm engaging with a 57-teeth Gear Wheel secured to an  $11\frac{1}{2}$ " Rod 2. At the upper end of the Rod 2 is a 1" Sprocket Wheel that meshes with a 2" Sprocket Wheel 3 bolted to the boom of the crane. The handle 4 is connected by means of a  $\frac{1}{2}$ " Pinion,  $1\frac{1}{2}$ " Contrate Wheel, and a 1" Sprocket Wheel 5 to the 2" Sprocket Wheel 6. The Rod 7, to which the latter is secured, is free to rotate in the boss of the Sprocket Wheel 3, and carries at its upper end a  $\frac{1}{2}$ " Contrate Wheel which, by means of a  $\frac{1}{2}$ " Pinion and a 57-teeth Gear Wheel, rotates the Rod 8. A cord wound on the latter Rod raises the pulley block 9. The handle 10 controls the traversing movement of the trolley by an endless rope drive similar to Standard Mechanism No. 169.

Model No. 66  
Vertical  
Steam Engine

Parts required :

2 of No. 12	1 of No. 45
1 " " 16	1 " " 52
1 " " 17	1 " " 59
1 " " 19m	1 " " 115
2 " " 20m	1 " " 162
3 " " 22	1 " " 163
1 " " 24	1 " " 164
9 " " 37	1 " " 166
2 " " 38	

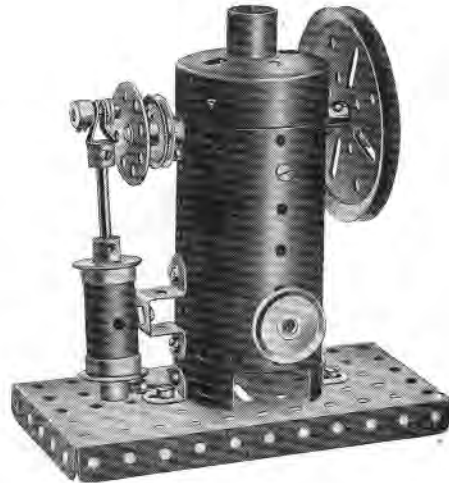

### Model No. 68 Revolving Crane

The jib of the crane is raised or lowered by means of the cord 1, one end of which is tied to a Flat Bracket 2 mounted on the Rod 4 in the gear box. The cord is led over the Rod 3, round Rod 4, again over Rod 3, and then is wound on the Rod 5. One end of the cord 6, which raises the hook 7, is tied to the jib of the crane and the other end is wound on the Rod 8. Each of the Rods 5, 8 carries a 57-teeth Gear Wheel (see Fig. 68a) that meshes with a Worm secured to a sliding 5" Rod 14, 15, to the opposite end of which is secured a  $\frac{3}{4}$ " Contrate Wheel. Two  $6\frac{1}{2}$ " Rods 9, 10 are connected to the Rods 14, 15 by means of Cranks, so that by operating their respective handles, the  $\frac{3}{4}$ " Contrate Wheels may be brought into engagement with  $\frac{1}{2}$ " Pinions 11, 12 secured one on each end of the armature of the Electric Motor.

A Spring 13, secured to the clutch Rod 9 by means of a Collar, ensures that the load is raised or lowered only while the clutch is held in position by the hand, but the clutch for raising and lowering the jib may be left in operation as long as desired.

All kinds of models, ranging from the most intricate to the simplest "00" structures, will appear in future issues of the "Meccano Magazine."

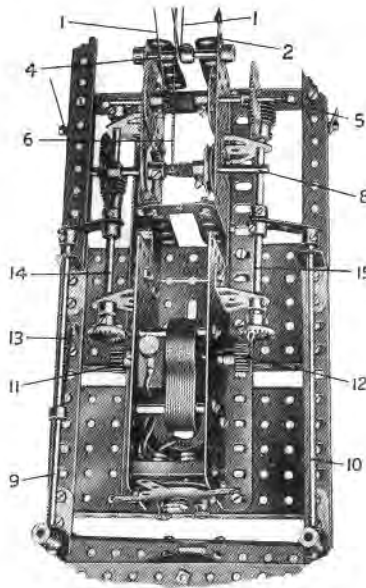
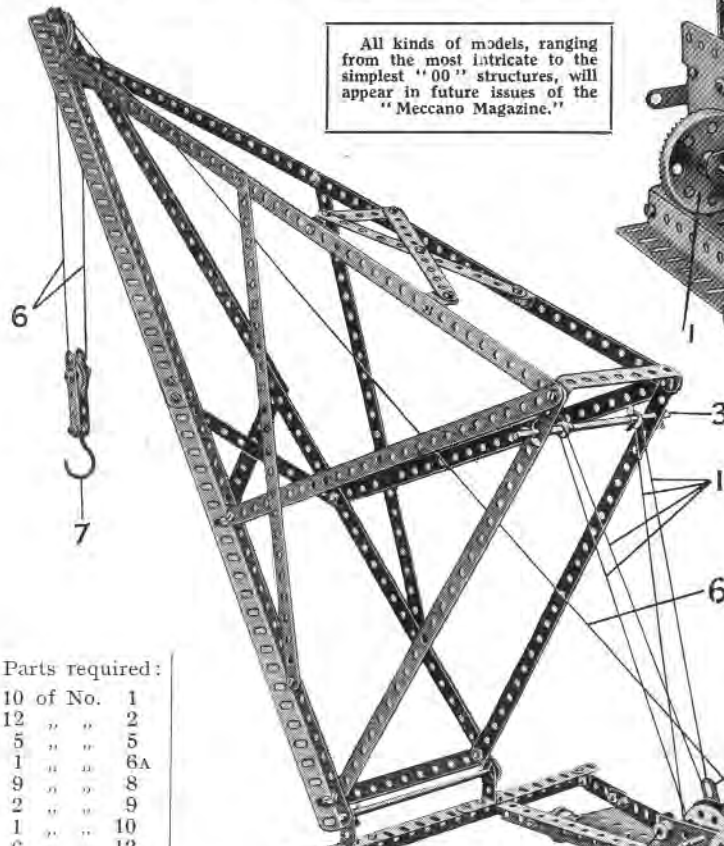

Fig. 68a

Parts required:

10	of No.	1
12	" "	2
5	" "	5
1	" "	6A
9	" "	8
2	" "	9
1	" "	10
6	" "	12
6	" "	12A
2	" "	14
4	" "	15
2	" "	15A
2	" "	16
2	" "	17
2	" "	19E
2	" "	20
2	" "	22
2	" "	22A
2	" "	24
2	" "	26
2	" "	27A
2	" "	29
2	" "	32

8	of No.	35
107	" "	37
6	" "	37A
10	" "	38
1	" "	43
2	" "	48A
1	" "	48B
2	" "	52
4	" "	53

2	of No.	54
1	" "	57
10	" "	59
2	" "	62
2	" "	63
2	" "	68
2	" "	111

4	of No.	111c
4	" "	126
2	" "	147B

### Model No. 69 Steam Winch

Parts required:

1	of No.	5	4	of No.	20
2	" "	8	2	" "	22
2	" "	9	1	" "	24
5	" "	10	1	" "	26
2	" "	12	1	" "	28
1	" "	12A	1	" "	32
1	" "	13A	30	" "	37
1	" "	15	9	" "	38
1	" "	16	1	" "	48A
			1	" "	52
			1	" "	59
			1	" "	103F
			1	" "	162
			1	" "	163

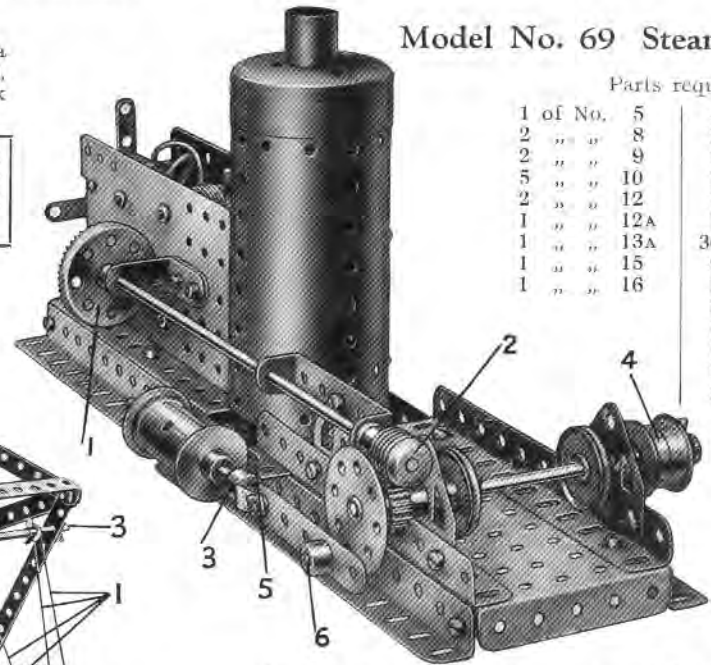

A  $\frac{1}{2}$ " Pinion secured to the armature of the Electric Motor turns a  $1\frac{1}{2}$ " Contrate Wheel 1 mounted on an 8" Axle Rod, to the opposite end of which is secured a Worm Wheel 2. The drum 4 of the winch consists of two  $\frac{3}{4}$ " Flanged Wheels and is secured to the end of a  $3\frac{1}{2}$ " Rod, which carries a  $\frac{1}{2}$ " Pinion that is driven by the Worm 2. The cylinder is composed of a Sleeve Piece, secured by two nuts and bolts to the end of a  $2\frac{1}{2}$ " Flat Girder 5, and two  $\frac{3}{4}$ " Flanged Wheels. The piston rod is attached pivotally to the connecting rod by means of an End Bearing 3, and the crank pin 6 is formed by a Threaded Pin secured to the Bush Wheel. The Boiler is secured in place by two Angle Brackets bolted to its base and to the  $5\frac{1}{2}$ " x  $2\frac{1}{2}$ " Flanged Plates forming part of the engine bed.

It will be noted that the 1" x 1" Angle Bracket supporting one end of the 8" Rod is spaced away from the Motor by a Flat Bracket, in order to obtain proper clearance for the Contrate Wheel 1.

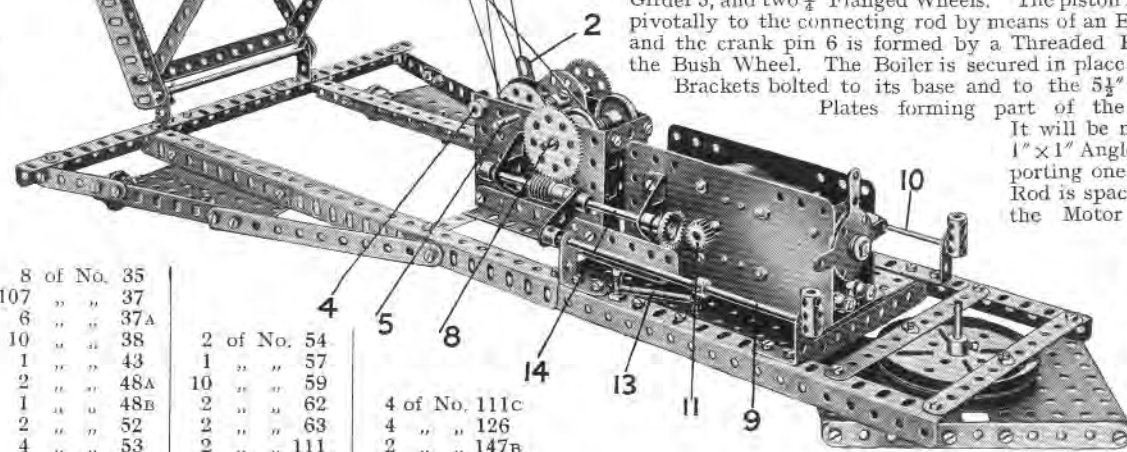



## Model No. 70 A Meccano Orrery

An orrery is a mechanical model that illustrates the motion of the planets and their moons about the Sun. It is impossible to represent the solar system mechanically with absolute accuracy, of course, the great difficulty being the correct reproduction of the sizes and distances apart of the planets. If the Earth, for instance, in such a model is represented by a sphere of the diameter and weight of a halfpenny, the Sun would have to be a huge globe weighing considerably more than a ton and the distance between their centres would require to be more than a quarter of a mile. On the same scale Neptune, the outermost planet, would be represented as a sphere more than five miles away from the Sun!

Nevertheless, it is possible to reproduce the movements of the planets with considerable accuracy in a Meccano model. The model depicted on this page demonstrates the annual journey of the Earth and its satellite, the Moon, round the Sun, and is yet another interesting illustration of the practical value of Meccano.

The movements to be represented are three in number. The Earth rotates round the Sun in the same time that it takes to rotate upon its own axis 365 times, while the Moon makes 13 revolutions round the Earth in the same period. The Moon always presents the same face to the Earth, and the axis of the latter body is so inclined that there is an angle between the plane of the equator and that of the Earth's orbit of  $23\frac{1}{2}$  degrees. These movements and positions are reproduced approximately in the model.

The Sun is indicated at 1, the Earth at 2, and the Moon at 3 (Fig. 70). Suitable spheres or balls to represent these bodies may be obtained quite easily, and no trouble should be found in securing them to their respective shafts. The appearance of the model will be enhanced if the globes are painted to represent the markings on the surfaces of the Earth and Moon, etc.

The Motor is mounted at the end of the revolving portion, or arm, of the model and its weight, together with that of the Meccano 8 ampere-hour Accumulator slung in a suitable frame beneath the Motor, serves to counter-balance the weight of the Earth and Moon, etc., on the other end of the arm.

The drive is led first to the Earth spindle 2a by way of two 3:1 reduction gears mounted on the Motor, and Bevel Wheel 4. The latter engages with a similar wheel secured to the shaft 5, which consists of two 8" Rods secured together by a Coupling. The other end of this shaft 5 carries a  $\frac{1}{2}$ " Pinion gearing with a  $1\frac{1}{2}$ " Contrate Wheel 6 secured to a vertical Rod that is connected to the Earth spindle 2a by means of a Universal Coupling 7. This allows the Rod 2a to be placed at an angle corresponding to the "tilt" of the Earth's axis.

The motion of the spindle 2a is conveyed to a short Rod 8 by means of a length of Sprocket Chain and two  $1\frac{1}{2}$ " Sprocket Wheels, and a  $\frac{3}{4}$ " Pinion secured to this Rod 8 drives a 50-teeth Gear Wheel

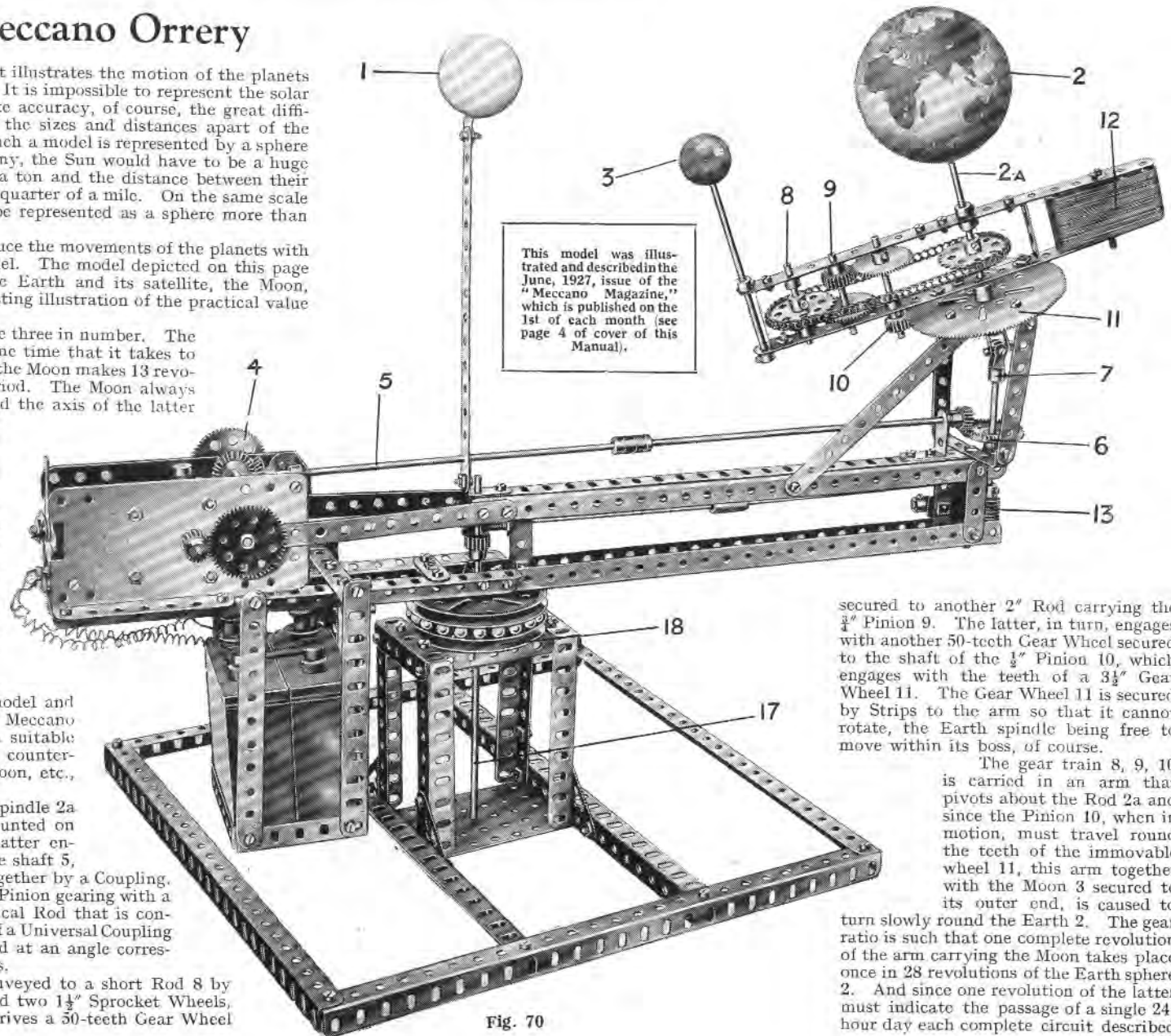

Fig. 70

secured to another 2" Rod carrying the  $\frac{3}{4}$ " Pinion 9. The latter, in turn, engages with another 50-teeth Gear Wheel secured to the shaft of the  $\frac{1}{2}$ " Pinion 10, which engages with the teeth of a  $3\frac{1}{2}$ " Gear Wheel 11. The Gear Wheel 11 is secured by Strips to the arm so that it cannot rotate, the Earth spindle being free to move within its boss, of course.

The gear train 8, 9, 10 is carried in an arm that pivots about the Rod 2a and since the Pinion 10, when in motion, must travel round the teeth of the immovable wheel 11, this arm together with the Moon 3 secured to its outer end, is caused to turn slowly round the Earth 2. The gear ratio is such that one complete revolution of the arm carrying the Moon takes place once in 28 revolutions of the Earth sphere 2. And since one revolution of the latter must indicate the passage of a single 24-hour day each complete circuit described

Meccano Orrery (Continued)

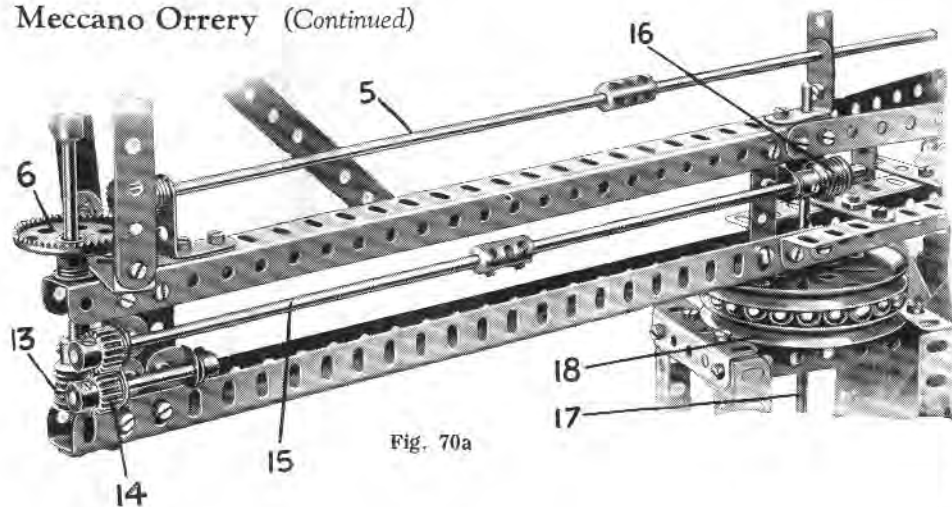

Fig. 70a

by the sphere 2 corresponds to the 28-day lunar month. The phenomenon of night, or the transit from daylight to darkness that takes place over the greater portion of the earth's surface once in every 24 hours, may easily be illustrated by adding a small electric light in place of, or in addition to, the Sun globe 1. In order to secure smooth working, the weight of the Moon and its gear train is counterbalanced by a series of 2 1/2" Strips 12 mounted on the opposite end of the revolving arm. Fig. 70a is a detail view of the model and shows the opposite side of the main revolving arm. From this illustration it will be seen that the lower portion of the Earth spindle carries a Worm 13 engaging with a 1/2" Pinion 14 that is secured to a short Rod journalled in the end of the arm. This Pinion 14 gears with a similar Pinion mounted on the end of a shaft 15, consisting of two 6 1/2" Rods secured end to end by a Coupling, on the other end of which is a second Worm 16 engaging with the teeth of a 1/2" Pinion secured to a vertical Rod 17. This Rod 17 is gripped by the set-screw of the 3" Pulley 18, which is bolted to the base and forms the fixed race of the ball bearings on which the movable portion of the model rests. The construction of the ball bearing unit is identical to that described under Meccano Standard Mechanism No. 104/5, the upper 3" Pulley of the unit being secured to the rotating superstructure. The Worm 16 is driven very slowly from the motion of the Earth spindle and because the 1/2" Pinion with which it gears is quite rigid, it has the effect of turning the whole superstructure about the Rod 17. Thus the Earth 2 and Moon 3 are carried round the Sun 1.

The two separate worm gears incorporated in the drive transmission reduce the speed of rotation to such an extent that the Rod 2a must rotate 361 times before the superstructure completes one revolution. This closely approximates to the actual number required, for the Earth revolves 365 times about its own axis while journeying once round the Sun. The sum of these 365 turns, or days, makes what we term a year.

Parts required:		Parts required:		Parts required:	
2 of No. 1A	2 of No. 9	3 of No. 15A	2 of No. 27A	2 of No. 53	
1 " " 1B	4 " " 9A	2 " " 18A	2 " " 30	10 " " 59	
5 " " 2	2 " " 9B	4 " " 17	3 " " 32	2 " " 63	
24 " " 5	4 " " 9C	2 " " 19A	154 " " 37	24 " " 117	
4 " " 6	2 " " 12A	2 " " 25	2 " " 48	1 " " 140	
1 " " 6A	3 " " 13A	8 " " 26	1 " " 48A	4 " " 151	
12 " " 8	3 " " 14	2 " " 27	3 " " 48B		

4-volt Electric Motor

Model No. 71 Heald-Making Machine

This model converts thin lengths of wire into healds for use in Meccano looms. Two typical specimens of healds made with the machine are shown in Fig. 71a. Two pairs of 2 1/2" x 2 1/2" Flat Plates form bearings for two 4 1/2" Axle Rods placed longitudinally in the model. One of these Rods carries a handle, composed of a Threaded Pin and Bush Wheel 1, and a 1/2" Pinion that engages with a 57-teeth Gear Wheel secured to an 8" Rod 3.

The other 4 1/2" Rod 2 revolves in the opposite direction to the handle 1, the reverse motion being obtained in the following manner. The inner end of the 8" Rod 3 is journalled in one end of a Coupling, through the centre hole of which passes the vertical 2 1/2" Rod 7. The latter carries a 3/4" Pinion and is journalled in the centre holes of two 2 1/2" x 1" Double Angle Strips bolted to the base Angle Girders. Another 8" Rod 4 is journalled in the opposite end of the Coupling, and this Rod is fitted with a 57-teeth Gear Wheel meshing with a 1/2" Pinion on the Rod 2. Rods 3 and 4 are both free to revolve in the ends of the Coupling, but the drive is transmitted from Rod 3 to Rod 4 via two 3/4" Contrate Wheels 5 and 6 and the Pinion on Rod 7; hence the direction of rotation of Rod 4 is reversed.

Each of the two 4 1/2" Rods is fitted with a Coupling carrying a Threaded Pin 8, 9 secured at right-angles to its end; these Pins form hooks over which is slipped the loop of wire from which the heald is formed. Each Rod is also equipped with a Compression Spring that is mounted between the inner 2 1/2" x 2 1/2" Flat Plate and a Collar on the Rod in such a way that it tends to hold the Coupling carrying the Threaded Pin against the Plate. Two Threaded Pins 10 and 11 are bolted to the side of the machine to form a gauge by which the correct length of wire may be ascertained.

The healds are manufactured as follows: A piece of suitable wire, about 13" in length, is passed round the Pins 10 and 11 and the ends twisted together with a pair of pliers to form a loop. A convenient size of wire is 26 S.W.G. (.018" in diameter).

Next the loop of wire is removed and passed over the Rod 7, and its ends slipped over the Pins 8 and 9. The hand wheel is now rotated and the loop of wire is twisted into the form of a heald, the Rod 7 forming the hole through which will pass the warp threads of the loom. As the loop of wire is twisted the 4 1/2" Rods carrying the Threaded Pins 8 and 9 are drawn slightly towards the Rod 7. This movement is allowed for by the small Compression Springs already mentioned.

Parts required:

2 of No. 6A	1 of No. 16A	2 of No. 29	2 of No. 59
2 " " 8	1 " " 25	46 " " 37	2 " " 63
2 " " 14	2 " " 26	2 " " 52	4 " " 72
2 " " 15A	2 " " 27A	4 " " 53	3 " " 115

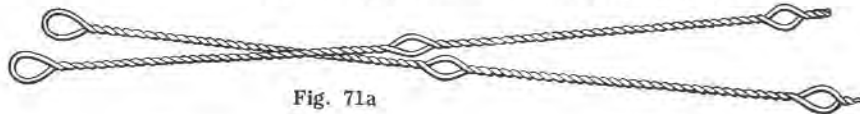

Fig. 71a

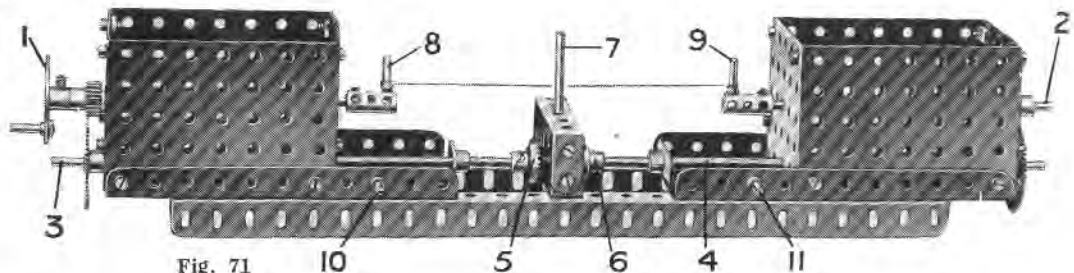

Fig. 71

### Model No. 73 Meccano Vernier Condenser

Radio enthusiasts should find the vernier condenser shown in Fig. 73 useful, for it provides extremely fine tuning facilities. The condenser plates 1 and 2 are formed from two Face Plates. Plate 1 is immovable and is secured to a 1" Axle Rod held in the Collar 3, the set-screw of which is replaced by a 2" Threaded Rod fixed in a vertical position in the boss of a Threaded Crank 4.

This Crank 4 is secured by two Meccano 6 B.A. Bolts to the base plate, and is insulated therefrom by Insulating Bushes and Washers placed upon the bolts above and below the Crank. Another Insulating Bush must be placed on each bolt below the base plate. The terminal 5 is attached to a 1 1/4" Strip forming an extension of the Crank 4.

The movable condenser plate 2 is secured to a 2" Threaded Rod engaging the longitudinal bore of the Threaded Boss 6. The boss is supported on another vertical Rod secured in a second Threaded Crank bolted to and insulated from the base plate in the same manner as the Crank 4. The set-screw 7 serves to reduce play in the horizontal Rod.

An insulated handle must be used in place of the Threaded Pin unless the terminal 8 can be connected to earth or to the positive terminal of the H.T. battery.

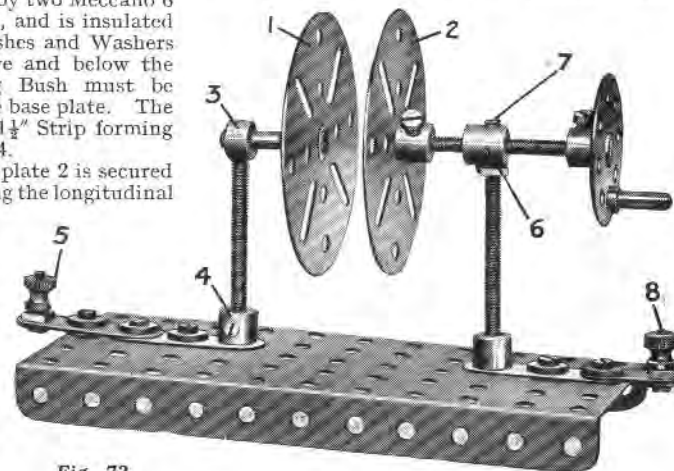

Fig. 73

Parts required:	1 of No. 18B	1 of No. 59	2 of No. 109	7 of No. 304
	1 " " 24	2 " " 62A	1 " " 115	7 " " 305
1 of No. 6A	1 " " 37A	1 " " 64	5 " " 302	2 " " 306
1 " " 10	1 " " 52	3 " " 81	5 " " 303	

### Model No. 74 The Meccangaroo

When placed upon an incline the "Meccangaroo" will "walk" with a quaint action. The positions of the various strips in relation to the body should be reproduced as accurately as possible, for the successful working of the model depends upon them.

The animal rocks about a short Rod secured between the rocker-frame which does duty as "legs." This frame consists of two 3 1/2" Strips 3 bolted at their upper ends to Cranks in which the short Rod is secured, and at their lower ends to two 2 1/2" large radius Curved Strips 4, which are connected together at their ends by 1 1/2" Strips 5 and braced to the Strips 3 by 2 1/2" Strips.

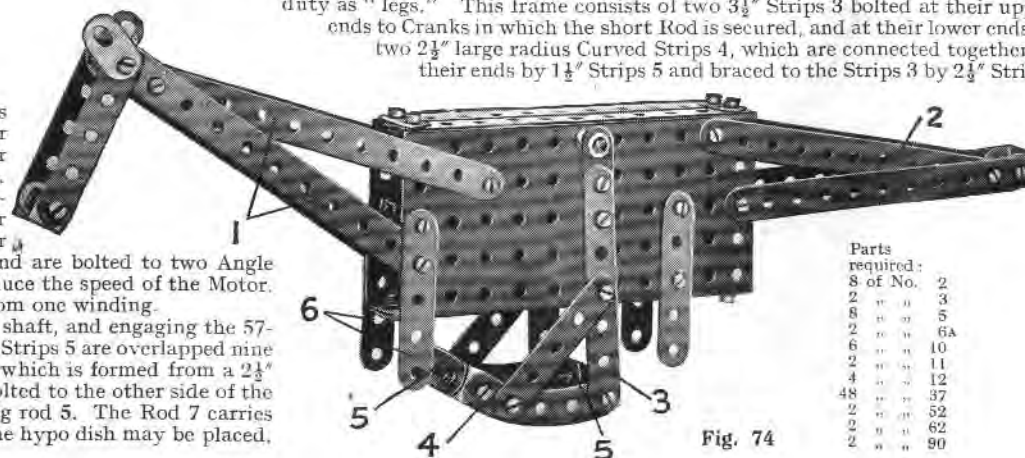

Fig. 74

Parts required:	
8 of No.	2
2 " "	3
2 " "	5
2 " "	6A
6 " "	10
2 " "	11
4 " "	12
48 " "	37
2 " "	52
2 " "	62
2 " "	90

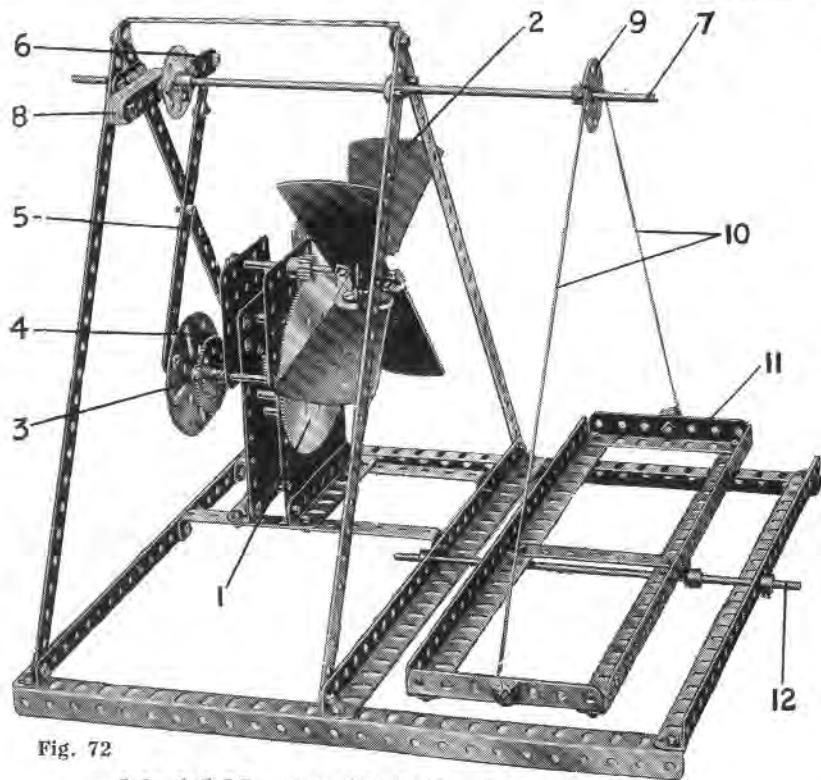

Fig. 72

### Model No. 72 Dish-Rocking Device

Parts required:					
4 of No. 1	7 of No. 8	2 of No. 16	52 of No. 37	2 of No. 72	
1 " " 2	4 " " 9B	3 " " 24	2 " " 37A	1 " " 109	
2 " " 3	12 " " 12	2 " " 26	1 " " 40	2 " " 111	
12 " " 5	1 " " 13	1 " " 27A	3 " " 48D	1 Clockwork Motor	
2 " " 6A	1 " " 13A	1 " " 27B	7 " " 59		

Those of our readers who are interested in photography will find the apparatus shown in Fig. 72 of considerable value. Its object is to impart a slight but regular rocking motion to the developing dish or hypo bath while developing negatives or fixing prints, thus ensuring that the contents of the dish are continually in motion.

The driving shaft of the Clockwork Motor carries a 3 1/2" Gear Wheel 1 that engages with a 1/2" Pinion on the shaft of the fan-wheel 2. The latter comprises four blades shaped from stout cardboard, each about 3" long and 2" wide at the outer end. The blades are slotted to fit over a Bush Wheel secured to the shaft and are bolted to two Angle Brackets, one on each side of the Bush Wheel. The object of the fan is to reduce the speed of the Motor. With the gearing shown the model will be found to run for fully ten minutes from one winding.

The model is driven from a 1/2" Pinion secured to the other end of the Motor shaft, and engaging the 57-teeth Gear Wheel 3 mounted on a 2" Axle Rod carrying a Face Plate 4. Two 5 1/2" Strips 5 are overlapped nine holes and attached pivotally to the Face Plate 4 and at the other end to a crank 6, which is formed from a 2 1/2" Strip bolted to a Bush Wheel secured to the 11 1/2" Rod 7. Eleven 2 1/2" Strips 8 bolted to the other side of the Bush Wheel form a counterbalance to the weight of the crank 6 and connecting rod 5. The Rod 7 carries another Bush Wheel 9 that is connected by cords 10 to the frame 11, on which the hypo dish may be placed,



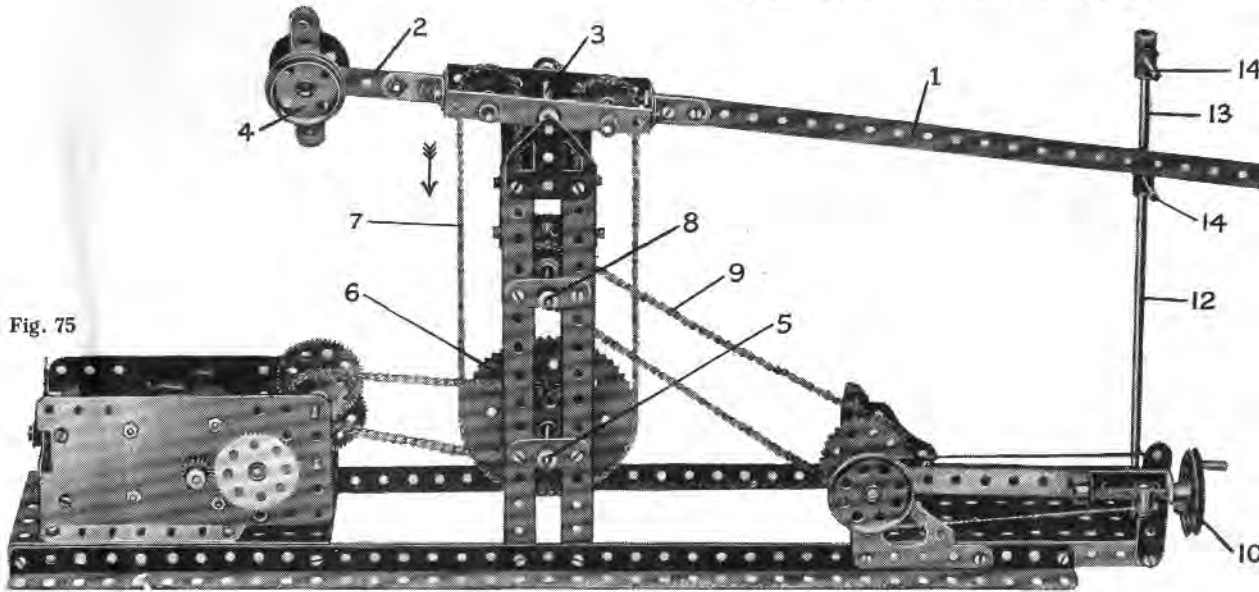

Fig. 75

### Model No. 75 Tatham Transmission Dynamometer

A transmission dynamometer is an instrument designed to measure the force of an engine while transmitting the power without other loss than that caused by friction in the apparatus.

The construction of the framework is quite simple. The upright member is built up from four  $7\frac{1}{2}$ " Angle Girders connected near the top by two  $2\frac{1}{2}$ " Strips and two Flat Trunnions. The movable arm, or steelyard 1, consists of a  $12\frac{1}{2}$ " Strip connected by means of two  $1" \times \frac{1}{2}"$  Angle Brackets to two  $3\frac{1}{2}" \times \frac{1}{2}"$  Double Angle Strips, and the other ends of the latter are connected by two further  $1" \times \frac{1}{2}"$  Angle Brackets to a  $2\frac{1}{2}"$  Strip 2.

The arm pivots about a  $3\frac{1}{2}"$  Rod 3, and suitable weights should be added at 4 so that it is exactly balanced about this point.

The drive from the Motor is led on to a 2" Sprocket Wheel secured to a  $3\frac{1}{2}"$  Rod 5, which carries also a 3" Sprocket Wheel 6. A length of Sprocket Chain 7 passes round this Sprocket 6, over two 1" Sprocket Wheels secured to 2" Rods journalled in the arm 1, one on each side of the fulcrum 3, and round a third 1" Sprocket Wheel secured to another  $3\frac{1}{2}"$  Rod 8. The drive is finally transmitted to the machinery that the Motor is required to operate by another length of Sprocket Chain 9, which passes over a second 1" Sprocket Wheel on the Rod 8.

For testing purposes the Rod driven by the Chain 9 must have varying degrees of

resistance, and the necessary adjustments are effected by a strap and screw brake 10, which is identical to Standard Mechanism No. 85. The Motor must be started in such a direction that the Chain 7 travels in the direction indicated by the arrow. The chain tends to pull down the shorter end of the arm 1 and the power of the Motor is gauged by the extent of this pull, which may be ascertained by placing a Scientific Hook (in different positions) on the arm. Different speed ratios should be arranged by changing the gears on the Motor, and the variation in the pull on the Chain 7 should be ascertained for each ratio.

The movement of the arm 1 is kept within certain limits by the stops 14. These consist of  $1\frac{1}{2}"$  Rods secured in Couplings and supported by a  $6\frac{1}{2}"$  Rod 12, which is gripped in the boss of a Crank bolted to the

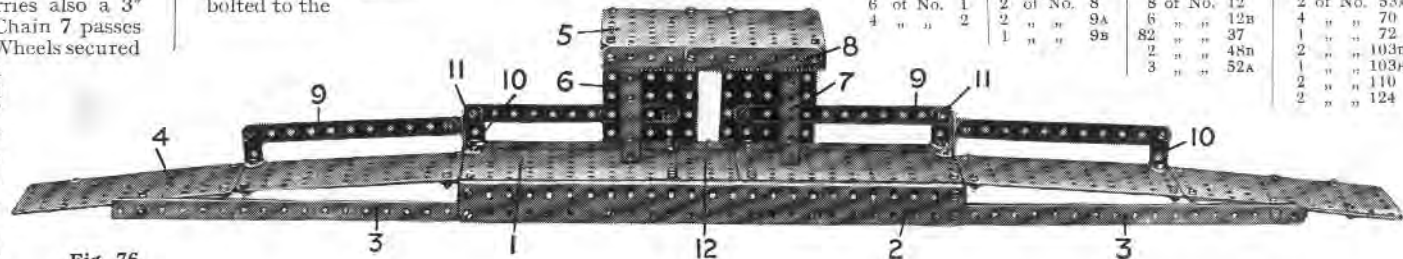

Fig. 76

base of the model. The  $6\frac{1}{2}"$  Rod is extended at the top by a 2" Rod 13.

Parts required:		
1 of No. 1	2 of No. 2	1 of No. 64
1 " " 2	3 " " 26	2 " " 66
11 " " 5	3 " " 27A	1 " " 81
4 " " 7A	46 " " 37	80" " " 94
2 " " 7A	2 " " 37A	2 " " 95
4 " " 8B	6 " " 38	1 " " 95B
4 " " 12n	1 " " 48	5 " " 96
1 " " 14	2 " " 48n	2 " " 108
4 " " 16	2 " " 52	1 " " 111c
3 " " 16A	1 " " 57A	1 " " 115
1 " " 17	14 " " 59	2 " " 126A
5 " " 18A	1 " " 62	14-volt Motor
2 " " 21	2 " " 63	

### Model No. 76 Wayside Station

The main platform is composed of  $5\frac{1}{2}" \times 3\frac{1}{2}"$  Flat Plates 1 and a  $5\frac{1}{2}" \times 2\frac{1}{2}"$  Flat Plate 12, bolted to  $12\frac{1}{2}"$  Angle Girders and supported by  $12\frac{1}{2}"$  Flat Girders 2. The approaches 4 are secured to Angle Brackets bolted near the ends of  $12\frac{1}{2}"$  Strips 3. The roof of the shelter is formed by a  $5\frac{1}{2}" \times 3\frac{1}{2}"$  Flat Plate 5 supported by two  $4\frac{1}{2}" \times 2\frac{1}{2}"$  Flat Plates 6 and  $3\frac{1}{2}" \times \frac{1}{2}"$  Double Angle Strips 7. Two Rack Strips 8 are added to complete the roof. The rails enclosing the platform are constructed from  $5\frac{1}{2}"$  Strips 9 supported by  $1" \times \frac{1}{2}"$  Angle Brackets 10. The corners of the main platform are negotiated by 1" Reversed Angle Brackets 11. A  $1\frac{1}{2}"$  Flat Girder should be bolted

*These models appeared recently in the "Meccano Magazine," and the article on the Dynamometer included particulars of experiments made with the machine. Naturally models can be described more fully in the Magazine than in the Instruction Manuals—that is why the "M.M." is read by every model-builder who is determined to derive maximum entertainment and instruction from his work.*

across the top of the opening at the back of the shelter, and in order to add further to the appearance of the model, steps, constructed from Angle Girders, may be added leading down from the opening to ground level.

Parts Required:		
6 of No. 1	2 of No. 8	8 of No. 12
4 " " 2	2 " " 9A	6 " " 12n
	1 " " 9B	82 " " 37
		2 " " 48n
		3 " " 52A
		2 of No. 53A
		4 " " 70
		1 " " 72
		2 " " 103n
		1 " " 103H
		2 " " 110
		2 " " 124

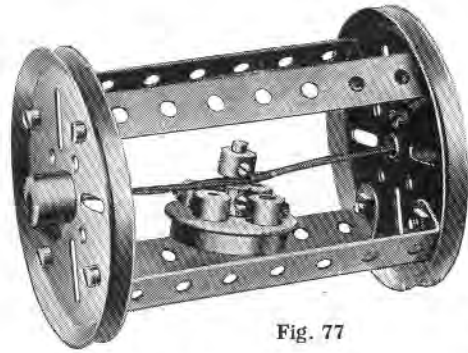

Fig. 77

### Model No. 77 The "Cum Bak"

The "Cum Bak"—shown in Fig. 77—should be rolled along the table or floor, when it will be found to return always to its starting point, although no outside influence of any kind is directed upon it. On its return journey it will sometimes overstep its commencing mark, but after a few oscillatory movements it will finally come to rest practically on the spot from which it started. If used on the floor a smooth surface must be found, such as wood or linoleum, for it will not work on carpets. The sides of the model should be covered by thin cardboard, or paper, to conceal the inner details, when its movements will puzzle even the "brainiest" Meccano boys.

It will be seen that the "Cum Bak" consists of a small drum built up from two 3" Pulley Wheels joined by four  $3\frac{1}{2} \times \frac{1}{2}$ " Double Angle Strips. Its mysterious antics depend entirely upon a short length of elastic and a suspended weight. The elastic is doubled and secured between the 3" Pulley Wheels, from centre to centre, and the weight, consisting of any suitable Meccano parts, is attached to it in the middle of the drum. The weight illustrated comprises a Flanged Wheel carrying four Collars, the set-screws of which grip the shanks of bolts passed through the Flanged Wheel.

As the drum rolls along, the weight tends to remain in its original position and the elastic therefore becomes twisted. The resistance in the elastic retards the drum to an increasing extent and finally stops it. The effort of the elastic to return to its former state then causes the drum to roll in the opposite direction. By the time the elastic has regained its normal position the drum has gathered a certain momentum, which usually carries it a little way past its starting point. It soon returns, however, and after a few short oscillations, it finally comes to rest practically at the spot from which it started its rolling movement.

The "Cum Bak" formed the subject of a popular competition in the "Meccano Magazine" a short time ago. Competitors were asked to explain how the movements described above were produced and some very ingenious solutions were submitted.

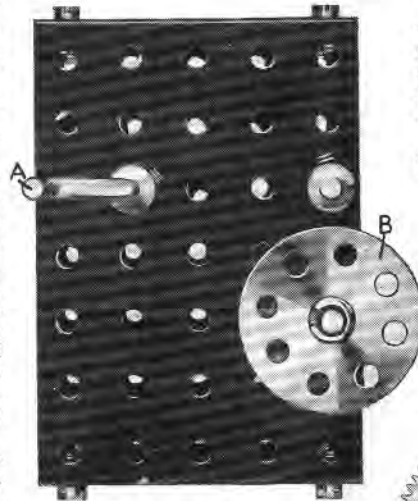

Fig. 78

The models illustrated on this page appeared at different times in the "Meccano Magazine" and each aroused extraordinary interest. They are reproduced here on account of the immense amount of fun that may be obtained with their aid. You should show the models to your chums, first taking care that the mechanisms are concealed completely, and then ask them to explain the methods of operation. If several people are present, prizes may be offered for the best solutions or suggestions.

### Model No. 78 The Mysterious Reversing Gear

Rotation of the handle A (Fig. 78) imparts motion to the shaft carrying the wheel B, but it produces the unusual result that the latter shaft persists in turning in a clockwise direction, no matter whether the movement of the handle A is clockwise or anticlockwise. Without a great deal of thought, even long-experienced model-builders find it difficult to suggest a means whereby this result may be produced.

Fig. 78a shows the reverse side of the model and, incidentally, solves the mystery. The end of the Crank Handle ("A" in Fig. 78) may be seen at 3, while 9 is the driven rod carrying the Bush Wheel B. The lever 1 and Simple Bell Crank 2 are free to turn about the Crank Handle 3, but are held in place by the Collar 4. Pivot Bolts 5 and 6 are passed through the Bell Crank and secured by the set screws of  $\frac{1}{2}$ " Pinions, sufficient play being allowed to permit the bolts to turn freely. The Pinions remain constantly in mesh with a 57-teeth Gear Wheel 7 secured to shaft 3. If the Crank Handle is rotated in a clockwise direction, when viewed as in Fig. 78a, the lever 1 and Bell Crank 2 swing about the point 3 until the Pinion on bolt 6 is brought into engagement with another 57-teeth Gear 8 on the driven shaft 9. In this position shaft 9 rotates in the same direction as the Handle 3.

If the rotation of the Crank Handle is reversed the lever unit moves round in an anticlockwise direction, throwing the lower Pinion out of gear with the wheel 8 and engaging the Pinion on bolt 5 with a further  $\frac{1}{2}$ " Pinion 10, and shaft 9 continues to rotate clockwise.

The Pulley 11 bolted to the lever 1 acts as a counterbalance and  $1 \times \frac{1}{2}$ " Angle Brackets 12 serve to restrict the movement of the lever.

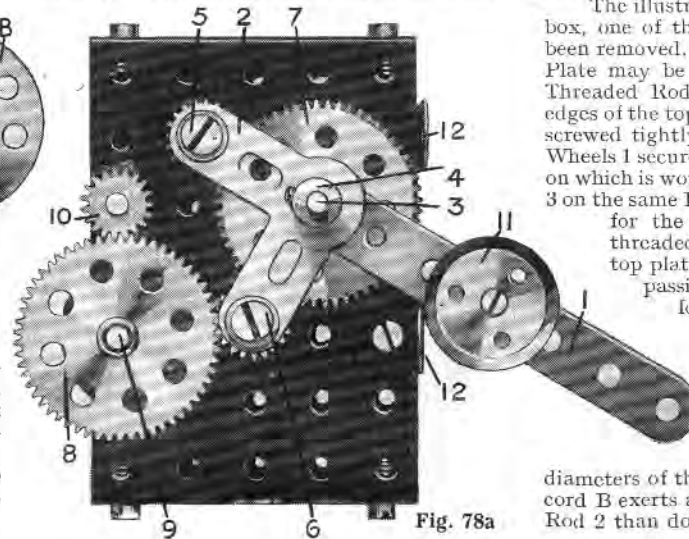

Fig. 78a

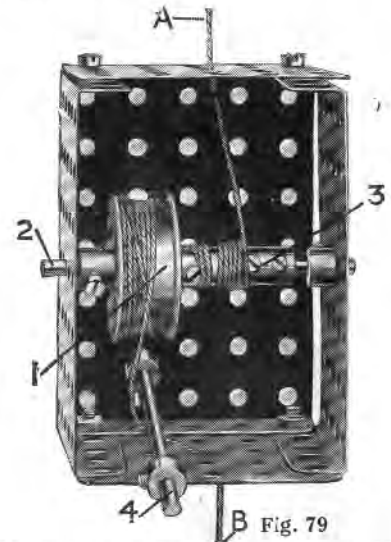

Fig. 79

### Model No. 79 The Magic Box

If the cords A and B of the Magic Box (Fig. 79) are held vertically in line and a slight pull applied to both, the box will remain stationary in mid-air. If the strain on the cords is increased, however, the box will climb the cord A, and if decreased the box will descend.

The illustration shows the interior of the box, one of the side Flanged Plates having been removed. When replaced, this Flanged Plate may be secured in position by a  $4\frac{1}{2}$ " Threaded Rod passed through holes in the edges of the top and bottom plates, with a nut screwed tightly against each. Two Flanged Wheels 1 secured on the 3" Rod 2 form a drum on which is wound the cord B, and a Coupling 3 on the same Rod performs a similar function for the cord A. The latter cord is threaded through the centre hole of the top plate of the box, and cord B, after passing round the 3" Rod 4, which forms a guide to keep the cord in line with the drum 1, passes through the central hole in the bottom of the box.

The movements of the box are explained, of course, by the difference in the diameters of the drums 1 and 3, for a pull on cord B exerts a much greater leverage on the Rod 2 than does a pull on cord A.

The Meccano movements shown on this and the following three pages have been selected from the "Suggestions Section" of various issues of the "Meccano Magazine." They are shown here because each movement is adaptable to a large number of models, and each should suggest to the keen Meccano boy quite a number of new models. The free-wheel device illustrated below, for example, could be adapted to Meccano roundabouts and similar rotating models, so that when power is shut off, the model continues to revolve by its own impetus for a short period before slowing down and finally stopping.

### No. 1 Free-Wheel Device

Fig. 1 shows a Meccano free-wheel mechanism attached to a 3" Sprocket Wheel. (If desired, the latter may be replaced by a 3½" Gear Wheel, large Pulley Wheel, or Face Plate, etc.) The Sprocket revolves by the Ratchet Wheel secured to the axle on one side and a Collar with set-screw on the other side.

Two Pawls are mounted pivotally on the face of the Wheel by means of Pivot Bolts and lock-nuts and are held in engagement with the teeth of the Ratchet by pieces of Spring Cord attached to set-screws in the bosses of the Pawls and to nuts and bolts secured to the face of the wheel. It will be evident that the axle and Sprocket Wheel can each move independently in one direction only. The driving power may be imparted primarily to either the axle or the wheel, to suit requirements.

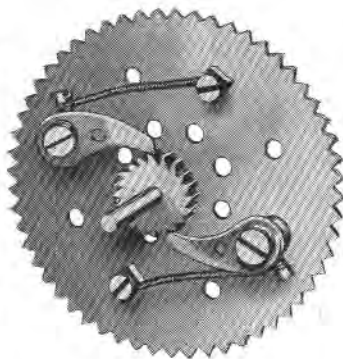

Fig. 1

### No. 2 Friction Grip Tong

Fig. 2 shows a friction grip, or lever grip-tongs, for use with block-setting cranes. The 3½" Strips 1, 5½" Strips 2, and 1½" Strips 3 are in duplicate, and the two sides of the frame so formed are spaced apart by Washers. Two 3½" Strips 4 secured to a Hook 5 slide between the Strips 3 and are guided by two ½" Loose Pulleys 6 held in place—one on either side of the Strips—by Collars 7. The ends of two 2½" Strips 8 are mounted pivotally on the axle of the Pulleys, and are connected at their outer ends by bolts and lock-nuts to 4½" Strips 9, which are free to move about bolts in the Strips 2. A cord 10 passes round one of the ½" Pulleys 6, and is secured to Strips 2.

Upon pulling the cord, the jaws of the grip are opened so that they fall on either side of the block that is to be raised. The dimensions of the blocks that

may be picked up are confined within certain limits, but these limits may be varied to some extent by moving the pivots of the Strips 9 to some other position in the transverse Strips 2.

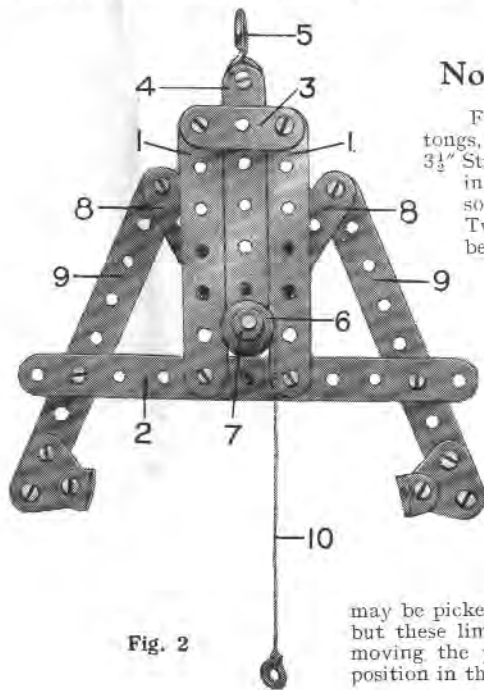

Fig. 2

### No. 3 Automatic Reversing Gear

A Reversing Gear that at regular pre-arranged intervals will automatically change the direction of rotation of a driven rod is shown in Fig. 3.

The power from the Motor may be led through any convenient gearing to the driven shaft 1 via the intermediate shaft 2. This shaft 2 carries a ¾" Pinion 3, in constant engagement with a 1½" Contrate Wheel 5, and a section of a Dog Clutch 4.

A short Threaded Rod 6 is inserted in the centre of the driven shaft and is secured between Couplings mounted on the short Rods 1 and 1a. The whole driven unit 1, 6, 1a is slidable in its bearings and carries a ¾" Pinion 7 and a Dog Clutch section 8. These are so arranged that when the clutch segments 8 and 4 are in engagement the Pinion 7 is out of mesh with the Contrate Wheel 5. In this position the shafts 1 and 2 rotate as one unit and the Contrate Wheel revolves idly. In the second position of the driven shaft the clutch is disengaged and the Pinion 7 engages the Contrate Wheel 5, with the result that Rod 1 is driven in a direction opposite to that of Rod 2, the drive now being transmitted by way of the Contrate 5.

The automatic reverse motion is effected as follows: A coupling 9 is free to turn about the Pivot Bolt 10 secured to the base of the model and carries a 2" Rod that is free to slide in a Double Bracket pivotally attached to a Threaded Boss 11 mounted on the Rod 6. A Spring 12 is connected to a point 13, 2½" from the bolt 10, and its other end is attached to a ¾" Bolt that serves to secure the Collar 14 on the 2" Rod.

The Motor must be started in a certain direction so that when the clutch segments 8 and 4 are engaged the Threaded Boss 11 advances towards the Rod 1. The clutch is held in engagement meanwhile by the Spring 12, but the Boss 11, moving slowly along the Rod 6, presently carries the Spring over the bolt 10. The Spring now tends to pull the Threaded Boss in the opposite direction and the driven unit slides over to the reverse position, wherein the Pinion 7 is engaged by the Contrate Wheel 5. The motion of the driven shaft is now reversed; hence the Boss 11 returns towards the Rod 1a until it again passes the centre point, when the driven shaft is pulled back to its original position and the cycle of operations is repeated.

The frequency at which the change-over movement occurs may be varied by (a) decreasing or increasing the speed of the shaft 2 in proportion to that of the Motor, or (b) increasing or decreasing the longitudinal sliding movement of the driven shaft and thereby varying the period required for the Threaded Boss 11 to reach the central position, where it effects the change-over.

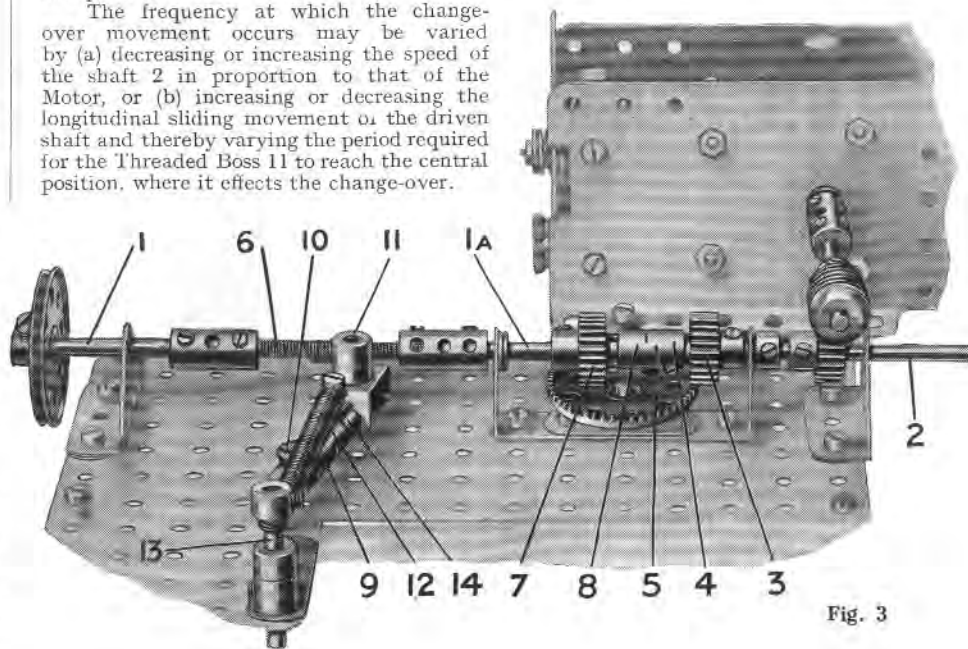

Fig. 3



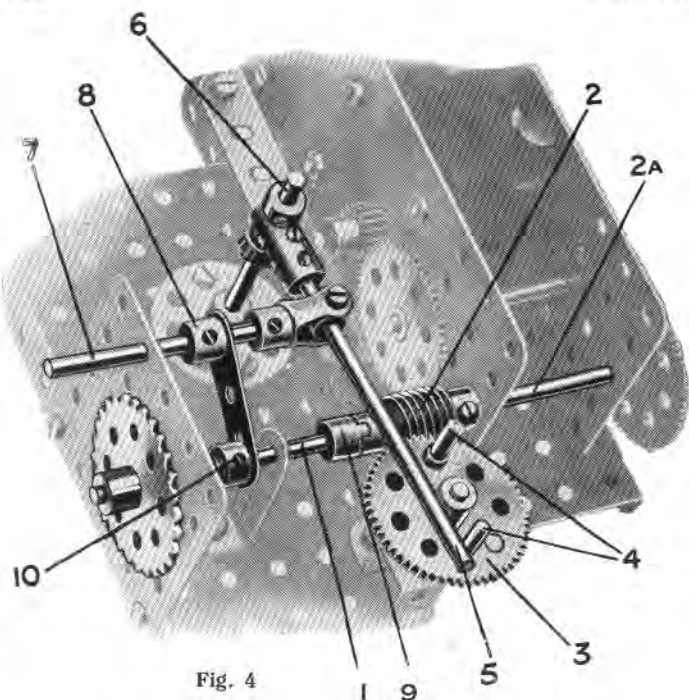

Fig. 4

#### No. 4 Intermittent Rotary Motion

The device shown in Fig. 4 is designed to convert continuous rotary motion to intermittent rotary motion. Rod 1 is the driven shaft. The drive from the Motor is led by any suitable means to a Worm Wheel 2 that meshes with a 57-teeth Gear Wheel 3, in the face of which two Threaded Pins 4 are secured.

As the Gear Wheel 3 slowly rotates the Threaded Pins 4 alternately press against the end of a  $3\frac{1}{2}$ " Rod 5, which is secured in a Coupling mounted on any suitable pivot 6. A Swivel Bearing forms a pivotal connection between the Rod 5 and a  $2\frac{1}{2}$ " Rod 7. This Rod 7 carries a Crank 8, through the end hole of which is journaled the driven shaft 1. The latter slides in its bearings and carries on its inner end a Dog Clutch section 9, the corresponding clutch section being secured to the driving Rod 2a. The clutch is normally held in engagement by means of a Compression Spring mounted on the driven shaft and pressing against a Collar 10.

When one of the Pins 4 strikes the lever 5, the Rod 7 is pushed back in its bearings, the Spring on the Rod 1 is compressed and the clutch members 8 disengaged. The Motor then rotates independently until the Gear Wheel 3 has carried the Threaded Pin far enough to allow the Rod 5, through the action of the spring on Rod 1, to slip back to normal position, when the Clutch is re-engaged. The cycle of operations is repeated when the second Threaded Pin strikes the Rod 5.

#### No. 5 Automatic Safety Device for Lifts

Fig. 5 shows an automatic locking device designed to prevent serious damage in the event of breakage of a lift hoisting cable. If such an accident occurs, the device promptly wedges the lift cage fast in the shaft, where it remains until the necessary repairs are effected. A similar arrangement is employed on many lifts in actual practice.

The special demonstration frame shown consists of two vertical  $18\frac{1}{2}$ " Angle Girders bolted to any suitable base and connected together at their upper ends by a  $3\frac{1}{2}$ " Double Angle Strip 2. (Three Washers are inserted between one end of the Strip 2 and the Angle Girder to obtain the necessary spacing). The cage itself is built up from  $3\frac{1}{2}$ "  $\times$   $5\frac{1}{2}$ " Flat Plates 5, which form the sides, and  $3\frac{1}{2}$ "  $\times$   $2\frac{1}{2}$ " Flanged Plates and  $3\frac{1}{2}$ " Double Angle Strips, representing the roof and floor. Spring Buffers 3 provided at the base of the shaft act as "cushions" for the descending cage.

The cage is retained in position between the vertical guides by means of  $5\frac{1}{2}$ " Flat Girders 6. Each Girder 6 is spaced away from the side of the lift by two  $5\frac{1}{2}$ " Strips, and the Girders 1 slide in the slots so provided. It will be noted that the guides are arranged in opposite positions; this prevents any movement of the cage except in a vertical direction.

The safety device is shown in detail in Fig. 5a. Two Pawls 7 are secured to 2" Axle Rods, which are journaled in the ends of two pairs of 1"  $\times$  1" Angle Brackets 8. These Brackets are bolted together in the manner shown and secured to the top of the lift by four 1"  $\times$   $\frac{1}{2}$ " Angle Brackets 9. The same bolts that secure the latter carry Double Brackets 10, which serve to strengthen the whole construction. This arrangement of the bearings for the 2" Rods is necessary in order to space the Pawls at the exact distance required from the vertical guides 1.

The hoisting cord 4, which may be controlled by any suitable machinery, is divided in two and connected to the set-screw of each Pawl 7. A piece of Spring Cord 11 secured between the Pawls tends to retain them in a horizontal position. When the cord 4 takes the

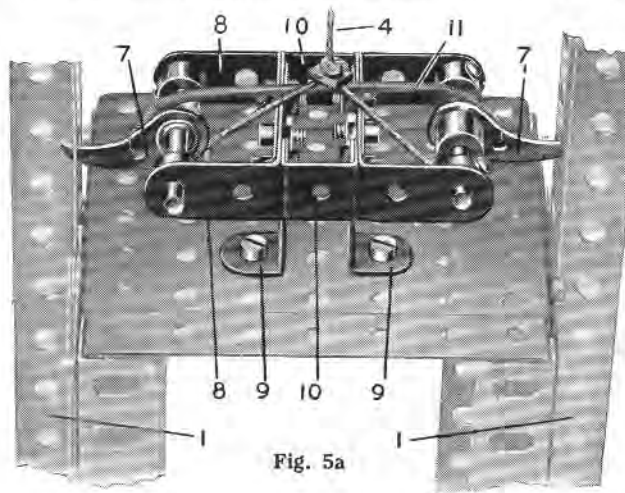

Fig. 5a

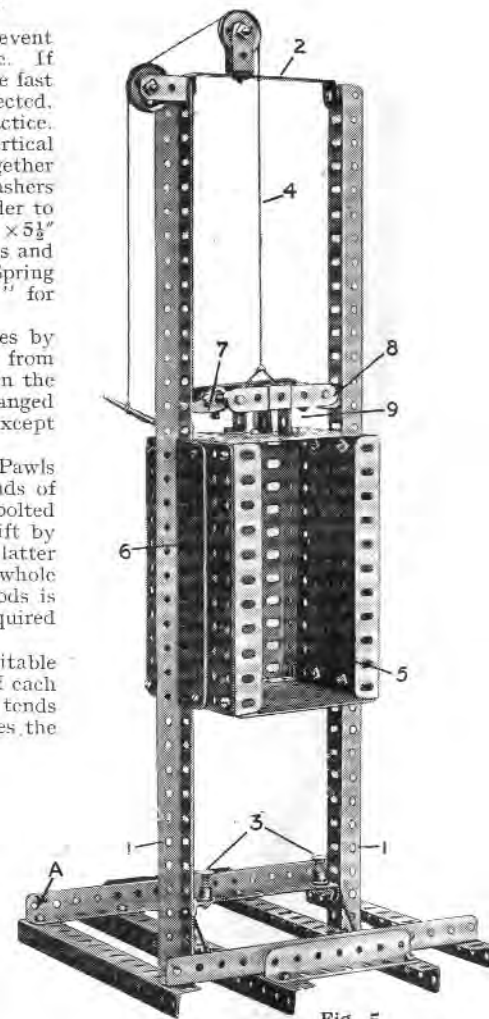

Fig. 5

weight of the lift, however, the Pawls are pulled downward and their ends brought clear of the Angle Girders 1. The cage is now free to move up or down. If the hoisting rope breaks the Spring 11 returns the Pawls to their original position, with the result that their ends engage the holes in the Girders 1 and the cage becomes firmly locked in position.

## No. 6 Radius Indicator for Meccano Cranes

The load capacity of a crane varies according to the particular angle of the jib, for the nearer the latter approaches the horizontal position the greater will be the strains upon it in proportion to the load.

This statement may be verified quite easily by applying the principle of the triangle of forces, which is summarised on page 202 of the complete Manual of Instructions as follows: If three forces meet at a point and are in equilibrium, and we know one of the forces, we may determine the other two by drawing a triangle, making each side parallel to the direction of one of the forces, and comparing the dimensions of the three sides. It will be found that these dimensions

are in the same proportion as the three forces.

In the case of a crane the three forces are (a) the load suspended from the head of the jib, (b) the tension member, or tie, which supports the jib (in luffing cranes the operating cable or chains, etc., with which the jib is raised or lowered correspond to the tie members), and (c) the jib, which acts as a strut to withstand the compressive force exerted by the combination of (a) and (b). All three forces meet in the head of the jib and counterbalance each other; that is to say, they are in equilibrium.

By drawing one or two triangles and showing the side that is parallel to the jib in a different position in each triangle,

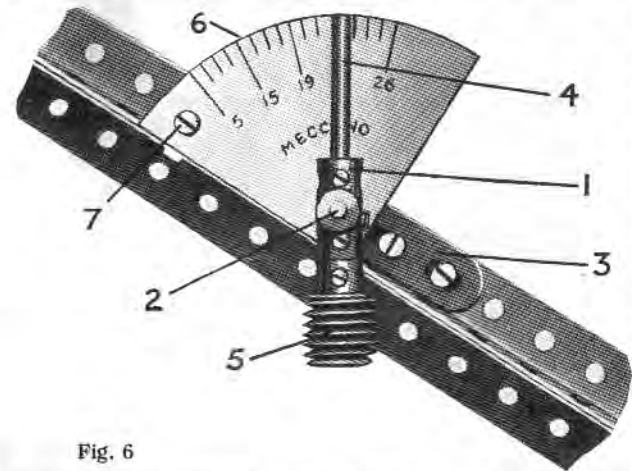

Fig. 6

it will be found that the strains that the crane structure must withstand increase as the jib approaches more nearly the horizontal position, as stated in our opening paragraph.

Therefore, when lifting a heavy load with a crane of this type, care must be taken to see that the jib is at the proper angle to cope with that load. A margin of safety is allowed, of course, for each of the various positions of the jib, but if this margin is overstepped, excessive strains may be set up in the structure and machinery. It is to minimise the possibility of such a mistake being made that a radius indicator is fitted to the majority of luffing cranes. A glance at this indicator tells the operator the position of the jib and the maximum load that he can handle safely without increasing the angle of the jib.

Fig. 6 shows a Meccano radius indicator attached to the side of the jib in the Meccano Stiff Leg Derrick (Model No. 709) and the actual position of the device in relation to the remainder of the model is indicated by the arrow in Fig. 6a. The Coupling 1 is free to turn about the  $1\frac{1}{2}$ " Axle Rod 2, which is gripped in the boss of a Crank 3 bolted to the upturned flanges of the jib girders. It carries in its upper end a further  $1\frac{1}{2}$ " Rod 4 and in its lower end a 1" Rod on which is secured the Worm 5. The weight of the latter serves to keep the Rod 4 always vertical, no matter in what position the jib is placed. A dial 6, shaped from a piece of stout cardboard, is bolted at 7 to an Angle Bracket attached to the jib. The Rod 2 passes through a hole in the dial and carries two or three Washers to space the Coupling 1 away from the card so that the Worm 4 will clear the edges of the girders forming the jib.

The dial moves with the crane, and the Rod 4, remaining vertical, acts as a pointer and registers the variations in the angle of the jib. It is a simple matter to set the jib in different positions, and to mark on the card the radius of the area covered by the load hook for each position of the pointer. The indicator may be fitted to most luffing cranes.

Fig. 6a

## No. 7 Automatic Reversing Hoist

This is a simple device by means of which a lift or similar model may be made to work for an indefinite period without attention.

The drive is taken from the Motor armature via a  $\frac{1}{2}$ " Pinion engaging with the 57-teeth Gear Wheel 1, and a  $\frac{1}{2}$ " Pinion on the opposite end of the rod carrying the Gear 1 meshes with another 57-teeth Gear on the 2" Rod 2. On the Rod 2 is a Worm 3 meshing with a  $\frac{1}{2}$ " Pinion secured to a vertical 3" Rod 4, which carries at its upper extremity a second Worm meshing with a  $\frac{1}{2}$ " Pinion on the  $3\frac{1}{2}$ " Rod 5. This Rod 5 carries a rotating arm 6, built up from  $5\frac{1}{2}$ " Strips secured rigidly to the Rod 5 by means of Bush Wheels. Two 1" loose Pulleys 7 are free to turn on a 2" Rod journalled in the arm 6 and two similar Pulleys 7a are mounted on a  $4\frac{1}{2}$ " Rod attached to the Motor.

The spindle of the Pulleys 7 follows the circular path traced out by the end of the arm 6, while the spindle of the Pulleys 7a is fixed. The cord 9, which is attached to the lift, is led down and over one of the 1" loose Pulleys 7a, round one of the Pulleys 7, back to the remaining Pulley 7a and thence to the second 1" Pulley 7. After passing round the latter, it is secured to the Flat Bracket 8. As the arm 6 rotates, the cord 9 is alternately drawn in and paid out, thus working the cage up and down the shaft.

In order to counterbalance the weight of the cage, a 50-gramme weight 10 should be attached to a cord that is led over the 1" Pulleys at the lift shaft head and secured to the top of the cage. The extent of the travel of the cage may be varied considerably by altering the distance between the Rod carrying the 1" loose Pulleys 7 and the Rod 5, adding to it to increase the travel of the cage and vice versa.

The "Suggestions Section," which appears in the "Meccano Magazine" every month, is a feature that no keen Meccano boy should miss, for it will keep him informed of the very latest developments in the Meccano world. Every idea published in it will suggest several new models to him, or will help him to perfect others he may have in mind.

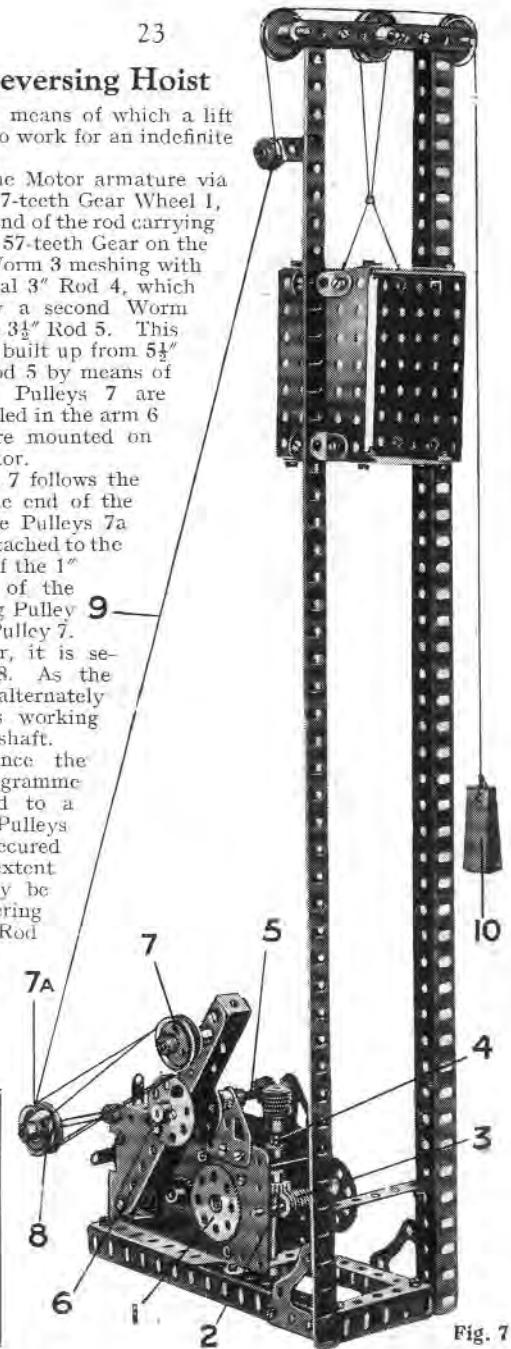

Fig. 7

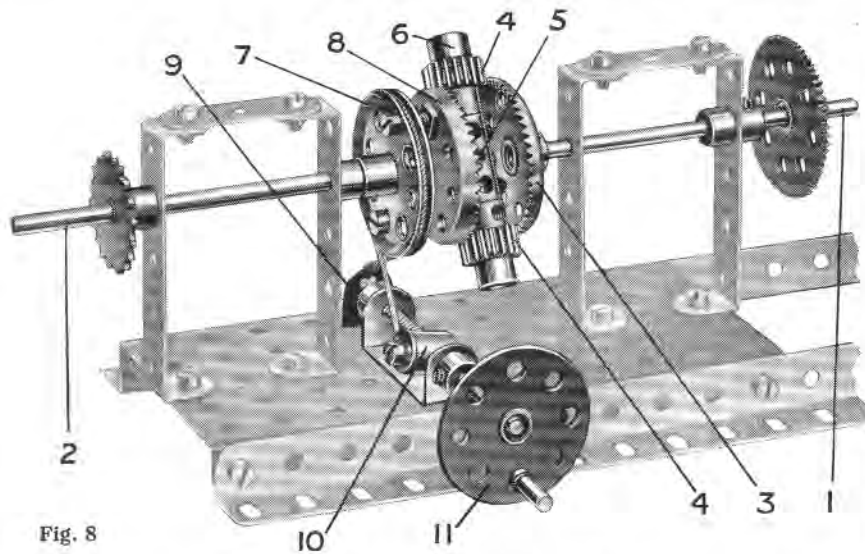

Fig. 8

### No. 9 Two-Speed and Reverse Planetary Gear Box

Fig. 9 shows a very compact Meccano gear box designed on the "planetary" principle. The drive from the Motor is directed to the Rod 1, and the motion is transmitted through the gear box to the driven Rod 2. A  $\frac{3}{8}$ " Pinion on the driving Rod engages with the  $3\frac{1}{2}$ " Gear Wheel 3, which is free to rotate independently about the Rod 2. The  $2\frac{1}{2}$ " Rod 4 is journalled in one of the holes in the face of the Gear Wheel 3 and carries a  $\frac{3}{4}$ " Pinion 5, 1" Gear Wheel 6 and  $\frac{1}{2}$ " Pinion 7, all fixed to the Rod. Its other end is supported in a  $2\frac{1}{2}$ " Strip 8 that is free to turn on the Rod 9.

The  $\frac{3}{4}$ " Pinion 10 is immovable, being gripped by its set-screw to a 2" Threaded Rod secured to the Gear Wheel 3 in a hole opposite to the Rod 4. Two nuts, one placed behind the  $3\frac{1}{2}$ " Gear Wheel and the other on the Threaded Rod immediately against the boss of the Pinion 10, are screwed up very tightly to secure the Pinion and the Threaded Rod rigidly to the wheel 3. Two Washers are placed between the Pinion and the  $3\frac{1}{2}$ " Gear Wheel.

The other end of the Threaded Rod enters a Threaded Boss 11 secured to the Strip 8 by a  $\frac{3}{8}$ " Bolt. The Coupling 12 is added to assist in balancing the weight of the Rod 4 and its components. The 50-teeth Gear Wheel 13, which forms the sun wheel, is secured to the driven Rod 2, and a Compression Spring is placed between it and the wheel 3. The spring normally holds the wheel 13 in gear with the  $\frac{3}{4}$ " Pinion 5.

The Rod 9 is slidable in its bearings but is prevented from rotating. It carries a 1" Gear Wheel 14 and 57-teeth Gear Wheel 15, both secured in position by their set-screws. The Rod protrudes about  $\frac{1}{8}$ " beyond the Gear Wheel 14. The operating lever 16, which pivots about a point 17, carries a Double Bracket fitted with a bolt that enters a Coupling 18 secured to the Rod 9.

The mechanism is shown in reverse gear with Gear Wheel 15 engaging Pinion 7. In this position Rod 2 rotates in the same direction as the driving Rod. "Neutral" is obtained by pushing the lever 16 forward so that the Gear Wheel 15 is disengaged from the Pinion 7; in this position the mechanism rotates bodily round the Rod 2 without turning the sun wheel 13. Additional movement of the lever brings Gear 14 into engagement with the corresponding Gear 6, thereby causing Rod 2 to turn slowly in an opposite direction to the driving Rod. This corresponds to a slow forward speed.

Further movement of the lever presses the protruding end of Rod 9 against the end of Rod 2 and throws the wheel 13 out of gear with the Pinion 5 and into engagement with the fixed Pinion 10. This locks the wheel 13 to wheel 3 and the two rotate as a single unit, thus producing, in effect, a straight-through drive. Rod 2 now rotates at maximum speed.

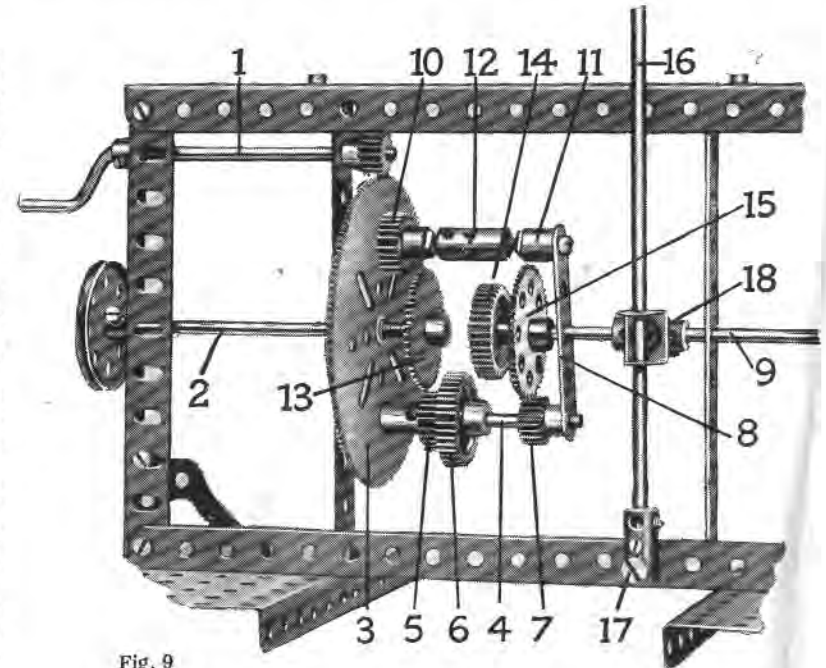

Fig. 9

### No. 8 Epicyclic Gear Clutch

Rod 1 is the primary, or driving shaft and Rod 2 is the secondary, or driven shaft. The former carries a  $1\frac{1}{2}$ " Contrace Wheel 3, which engages with  $\frac{1}{2}$ " Pinions 4 mounted on 1" Axle Rods secured in the ends of a Coupling 5. The Pinions are free to revolve on their axles, but are held in place by Collars 6. Rod 2 passes through the bosses of a Pulley 7 and the second  $1\frac{1}{2}$ " Contrace Wheel 8, and its inner end is secured in the centre of the Coupling 5. The Pulley 7 and Contrace Wheel 8 are free to turn independently of the Rod 2, but they are secured together by two  $\frac{1}{2}$ " Bolts, each of which is equipped with three nuts, one immediately behind Pulley 7 and one on each side of the Contrace Wheel 8.

The Wheel 7 is controlled by a friction brake consisting of a length of cord, one end of which is tied to an Angle Bracket 9 and the other end to a Threaded Boss 10 mounted on a Threaded Rod that carries a hand wheel 11.

If the brake is in the "off" position, that is with cord slack, the unit 7 and 8 is free to revolve about the Rod 2. Hence if power is applied to the Contrace Wheel 3 the Pinions 4 commence to turn upon their axles, driving the Contrace Wheel 8 in an opposite direction, and no movement is imparted to the Rod 2. If the hand wheel 11 is rotated, so gradually applying the brake, the Contrace Wheel 8 becomes increasingly difficult to turn, and the Pinions 4 commence to climb round its teeth, thereby rotating the Coupling 5 and the Rod 2.

It will be seen that by means of this clutch the power can be applied to the load very smoothly and without shock, for the Rod 2 commences to rotate immediately the resistance on the Pulley 7 becomes greater than the load (that is the resistance on Rod 2). The speed of the latter Rod increases in proportion to the increase in the resistance on Pulley 7 and the maximum speed is reached when the movement of the Pulley ceases altogether. It should be noted that the gear ratio is one in two when the unit 7, 8 is immovable—that is, Rod 2 rotates only once in every two revolutions of Rod 1.



# NEW MECCANO ACCESSORY PARTS

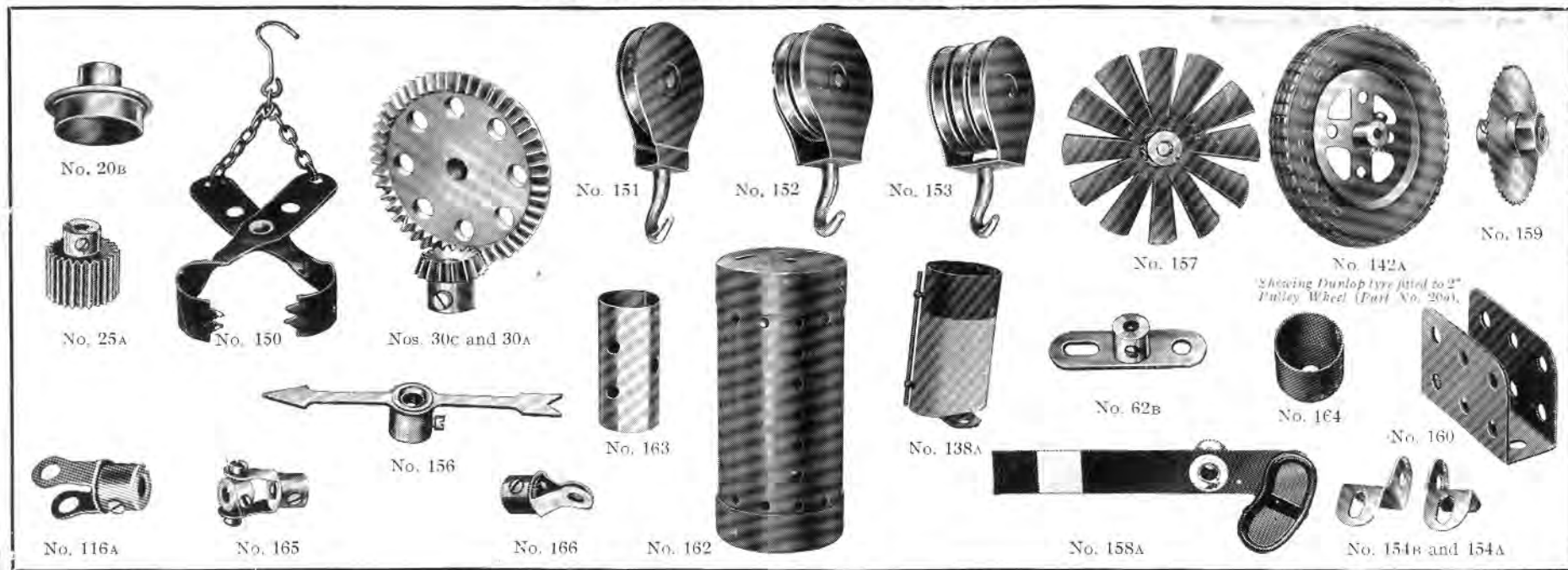

Part No.	s.	d.	Part No.	s.	d.	Part No.	s.	d.	
20b.	Flanged Wheels, $\frac{3}{8}$ " diameter ...	each	0	6	116a.	Fork Piece, small ...	each	0	5
	Designed to fit over the ends of the Sleeve Piece to form a complete cylinder unit; may also be used as travelling wheels in all models that are required to run on rails.					Designed for pivotal connections between Rods and Strips, etc. Forms an excellent bearing for $\frac{1}{2}$ " loose Pulleys, which may be mounted on a bolt passed through the arms of the Fork Piece.			
25a.	Pinion, $\frac{3}{8}$ " diam., Double-width Face	each	0	11	120b.	Compression Spring ...	each	0	2
26a.	Pinion, $\frac{1}{2}$ " diam., Double-width Face	each	0	8		Will fit over Axle Rods and may be used for innumerable purposes.			
	These should prove extremely useful in connection with Meccano gear boxes and toothed driving mechanism, etc. They engage respectively with the 50- and 57-teeth Gear Wheels.				138a.	Ship's Funnel, Cunard type ...	each	1	2
30c.	Bevel Gear, $\frac{1}{2}$ " diam., 16 teeth ...	each	0	8		Oval in shape, raked, and fitted with a miniature steam pipe. Enamelled red with black band at top.			
	These are designed to provide a 1:3 ratio right-angle drive and should only be used together. Two of 30a or two of 30c should not be mounted together to produce a 1:1 ratio. When such a ratio is required, two $\frac{1}{2}$ " Bevel Wheels (part No. 30) should be employed.				142a.	Dunlop Tyres, 2" inside diameter	each	0	6
52.	Flanged Plate, $5\frac{1}{2}$ " x $2\frac{1}{2}$ " ...	each	0	7	142b.	Dunlop Tyres, 3" inside diameter ...	each	0	9
	Improved design. Fitted with flanges on all four sides and provided with a slot to receive the blade of the Meccano Circular Saw and an elongated hole for adjusting purposes.					Designed to fit Meccano 2" and 3" Pulley Wheels respectively. Will add an excellent finish to Meccano model motor cars, etc.			
54.	Sector Plate ...	each	0	5	150.	Crane Grab ...	each	0	10
	Improved design. Provided with three parallel rows of holes at centre of plate.					For use in place of the ordinary crane hook. Miniature stone blocks, boxes, etc., may be gripped in its jaws and lifted without other aid.			
62b.	Double Arm Crank ...	each	0	4	151.	Pulley Block, single sheave ...	each	1	0
	In addition to its uses as a crank or lever, this may be used as a reinforced bearing for shafts or as a method of securing Rods to Strips.				152.	Pulley Block, two sheaves ...	each	1	2
					153.	Pulley Block, three sheaves ...	each	1	5
						For use in model cranes, derricks, boat davits, etc. Very compact and of realistic appearance.			
					154a.	Corner Angle Bracket, right-hand ...	$\frac{1}{2}$ doz.	0	8
					154b.	Corner Angle Bracket, left hand ...	$\frac{1}{2}$ doz.	0	8
						For use in cases where two $\frac{1}{2}$ " x $\frac{1}{2}$ " Angle Brackets bolted together would prove either too cumbersome or insufficiently rigid.			
					156.	Pointer, with boss and set-screw ...	each	0	6
						For all indicating appliances, revolution counters, etc.			
					157.	Fan, 2" diameter, with boss and set-screw	each	0	6
						Specially suited for use as a radiator cooling fan in Meccano motor cars, etc.			
					158a.	Signal Arm, "Home" type ...	each	0	8
					158b.	Signal Arm, "Distant" type ...	each	0	8
						May be used in Meccano signal gantries, etc., in conjunction with miniature railways.			
					159.	Circular Saw ...	each	1	5
						Of specially fine steel, teeth tempered and ground. When driven at a high speed, the saw will cut thin pieces of wood, etc.			
					160.	Channel Bearing ...	each	0	3
						Designed to form rigid bearings for Axle Rods, etc., where space is restricted.			
					162.	Boiler, with ends ...	each	1	5
					162a.	Boiler Ends ...	each	0	5
						May be incorporated in Meccano locomotives, stationary engines, and numerous other models of a similar type.			
					163.	Sleeve Piece, $1\frac{3}{8}$ " x $\frac{5}{8}$ " ...	per pair	0	8
						When fitted with a $\frac{1}{2}$ " Flanged Wheel at each end, this part forms an excellent cylinder.			
					164.	Chimney Adaptor ...	each	0	3
						Forms a suitable chimney for model locomotives, etc.			
					165.	Swivel Bearing ...	each	0	9
						Intended for coupling two Rods together end to end, so that one may move radially about the end of the other.			
					166.	End Bearing ...	each	0	5
						May be used as an End Bearing for connecting rods, or as a method of pivotally coupling a Rod and a Strip end to end.			



# MECCANO



Price 6d.



# MAGAZINE

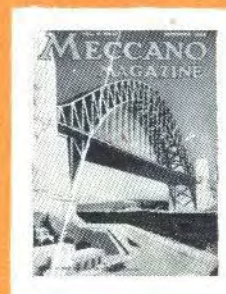

Price 6d.

## A Fine Engineering Monthly for Boys

The "Meccano Magazine" is the Meccano boy's newspaper. He reads it regularly and corresponds with his friend the Editor when he feels inclined.

The Magazine tells him of the latest Meccano models ; what Meccano Clubs are doing ; how to correspond with other Meccano boys ; the Competitions that are running. It contains splendid articles on such subjects as Railways, Famous Engineers and Inventors, Electricity, Bridges, Cranes, Wonderful Machinery, Aeroplanes, Latest Patents, Radio, Stamps, Photography, Books and other topics of interest to boys, including suggestions for new Meccano

parts and correspondence columns in which the Editor replies to his readers' enquiries. The publishing date is the 1st of each month.

Write to the Editor, "Meccano Magazine," Binns Road, Liverpool, enclosing 6d. in stamps. He will then forward a specimen copy of the "M.M.," post free. If you wish to become a regular subscriber the rates are 4/- for six issues or 8/- for twelve issues, post free.

If you prefer to do so, you may order the Magazine from your Meccano dealer or from any newsagent or bookstall, price 6d. Order early to avoid disappointment.

*Meccano and Hornby Train Agents for New Zealand and Fiji:*

**MODELS LTD., Kingston Street, AUCKLAND (P.O. BOX 129)**

*Published by:*

**MECCANO LIMITED, LIVERPOOL, ENGLAND**