

# METALING®

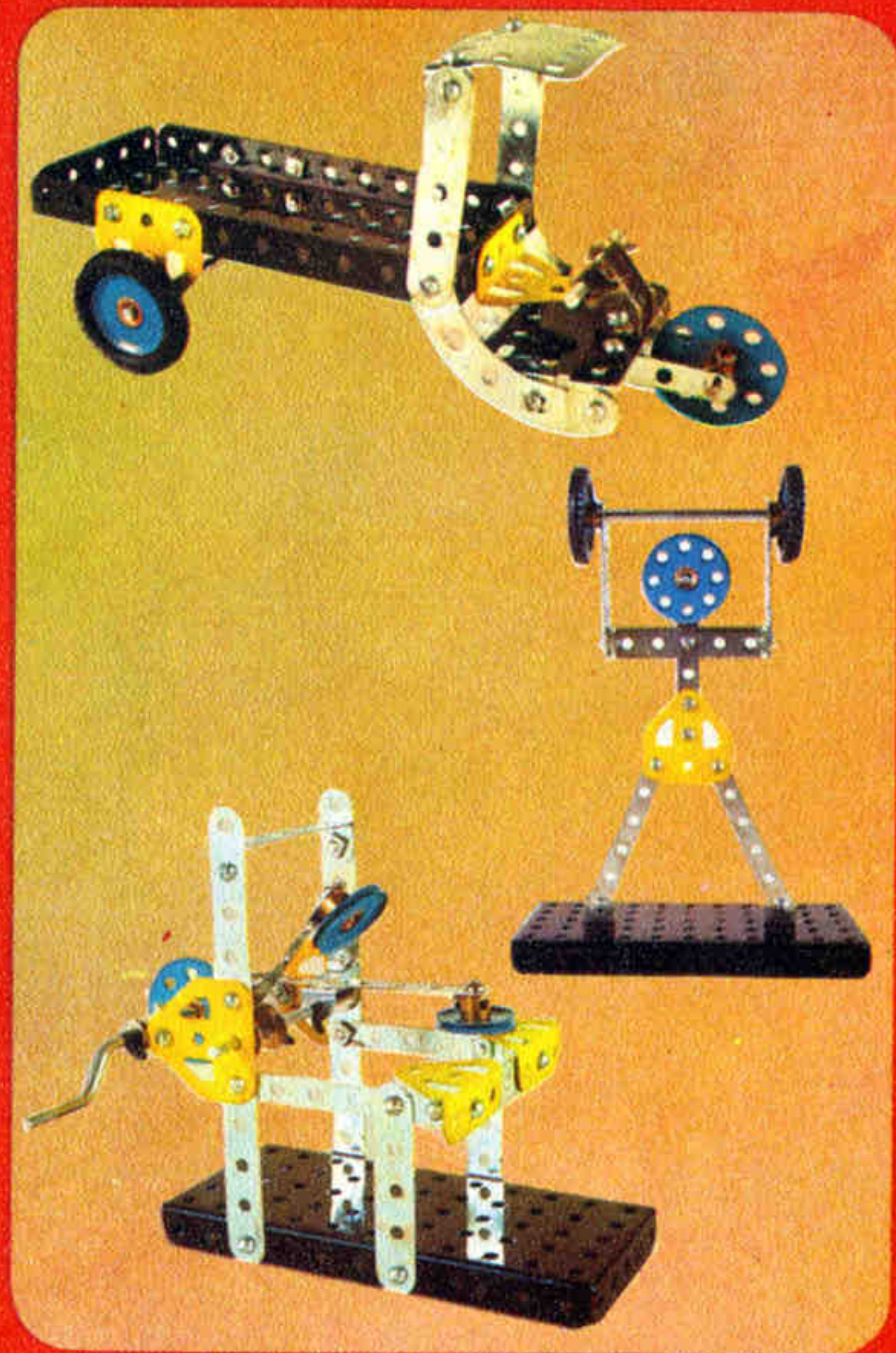

# ÍNDICE GENERAL DE PIEZAS



## TIRAS

- |                       |                     |
|-----------------------|---------------------|
| 1 - 25 aguj. 32 cm.   | 3 - 7 aguj. 9 cm.   |
| 1a - 19 aguj. 24 cm.  | 4 - 6 aguj. 7,5 cm. |
| 1b - 15 aguj. 19 cm.  | 5 - 5 aguj. 6 cm.   |
| 2 - 11 aguj. 14 cm.   | 6 - 4 aguj. 5 cm.   |
| 2a - 9 aguj. 11,5 cm. | 6a - 3 aguj. 4 cm.  |

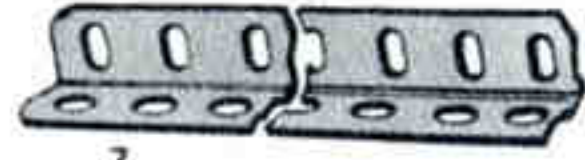

## VIGUETAS

- |                      |                       |
|----------------------|-----------------------|
| 7 - 49 aguj. 62 cm.  | 9a - 9 aguj. 11,5 cm. |
| 7a - 37 aguj. 47 cm. | 9b - 7 aguj. 9 cm.    |
| 8 - 25 aguj. 32 cm.  | 9c - 6 aguj. 7,5 cm.  |
| 8a - 19 aguj. 24 cm. | 9d - 5 aguj. 6 cm.    |
| 8b - 15 aguj. 19 cm. | 9e - 4 aguj. 5 cm.    |
| 9 - 11 aguj. 14 cm.  | 9f - 3 aguj. 4 cm.    |

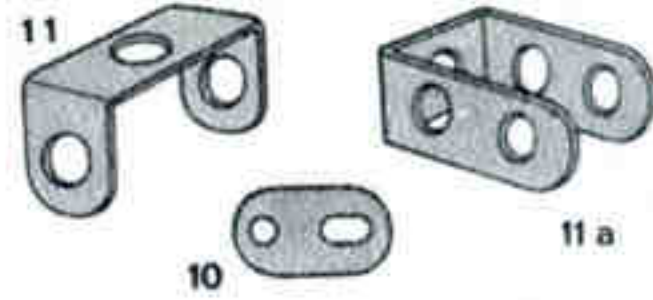

- 10 - Soporte plano
- 11 - Soporte doble
- 11a - Soporte doble 2x1 aguj.

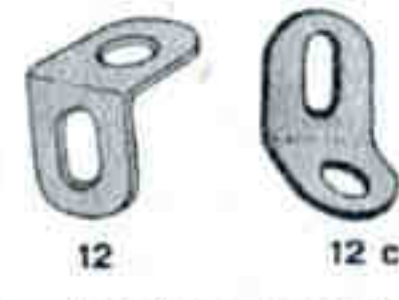

- 12 - Soporte angular 1x1 aguj.
- 12a - Soporte angular 2x2 aguj.
- 12b - Soporte angular 2x1 aguj.
- 12c - Soporte angular obtuso



## EJES

- |                |               |
|----------------|---------------|
| 13 - 29 cm.    | 16 - 9 cm.    |
| 13a - 20 cm.   | 16a - 6 cm.   |
| 14 - 16,5 cm.  | 16b - 7,5 cm. |
| 14a - 14 cm.   | 17 - 5 cm.    |
| 15 - 13 cm.    | 18a - 38 mm.  |
| 15a - 11,5 cm. | 18b - 25 mm.  |
| 15b - 10 cm.   |               |

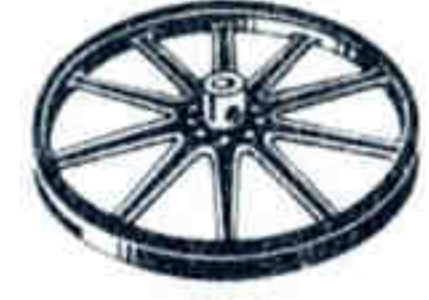

19a - Rueda radial 75 mm. Ø



19b

- 19b - Polea 75 mm. Ø con buje
- 20a - Polea 50 mm. Ø con buje



20a

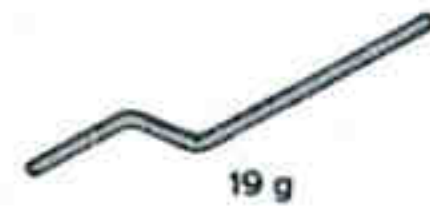

19g

- 19g - Manivela 90 mm.
- 19h - Manivela 125 mm.



20b

- 20 - Rueda rebordeada 28 mm. Ø
- 20b - Rueda rebordeada 19 mm. Ø

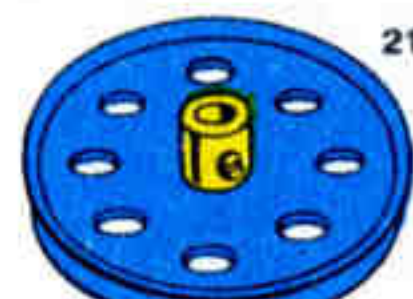

21

- 21 - Polea 38 mm. Ø con buje
- 22 - Polea 25 mm. Ø con buje
- 22a - Polea 25 mm. Ø sin buje

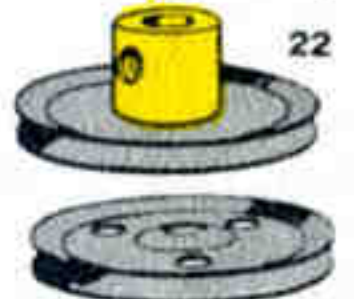

22

22a



23

- 23 - Polea 12 mm. Ø
- 23a - Polea 12 mm. Ø con buje



23a



24

- 24 - Rueda 34 mm. Ø 8 aguj.
- 24a - Disco 34 mm. Ø 8 aguj.
- 24b - Rueda 34 mm. Ø 6 aguj.
- 24c - Disco 34 mm. Ø 6 aguj.



24c



26

- 25 - Piñon 25 dientes 19x6 mm.
- 26 - Piñon 19 dientes 13x6 mm.

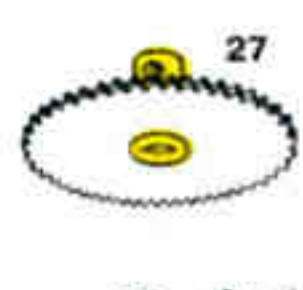

27



27a

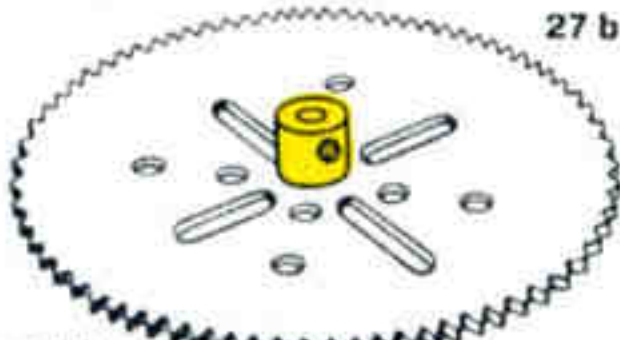

27b

- 27 - Rueda 50 dent. (Engrana piñón n°. 25)
- 27a - Rueda 57 dent. (Engrana piñón n°. 26)
- 27b - Rueda 133 dent. (Engrana piñón n°. 26)
- 27c - Rueda 95 dent. (Engrana piñón n°. 26)



28

- 28 - Rueda catalina 38 mm. Ø 50 dent.
- 29 - Rueda catalina 19 mm. Ø 25 dent.



30

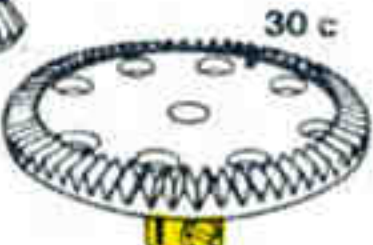

30a

- 30 - Rueda cónica 22 mm. Ø 26 dientes
- 30a - Rueda cónica 12 mm. Ø 16 dientes
- 30c - Rueda cónica 38 mm. Ø 48 dientes

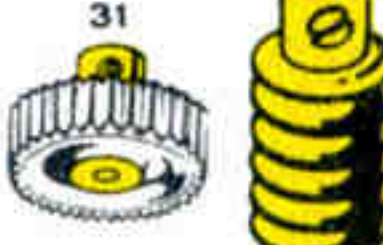

31

- 31 - Rueda 25 mm. 38 dientes
- 32 - Engranaje sin fin
- 33 - Engranaje universal 45 mm. Ø



32



33

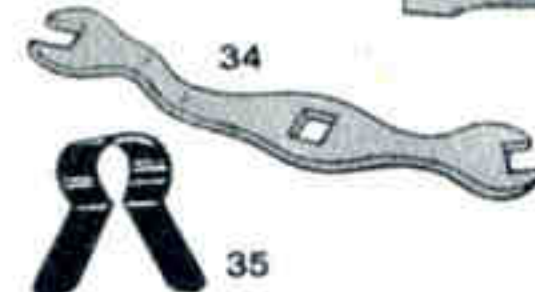

34



35

- 34 - Llave
- 35 - Abrazadera de resorte

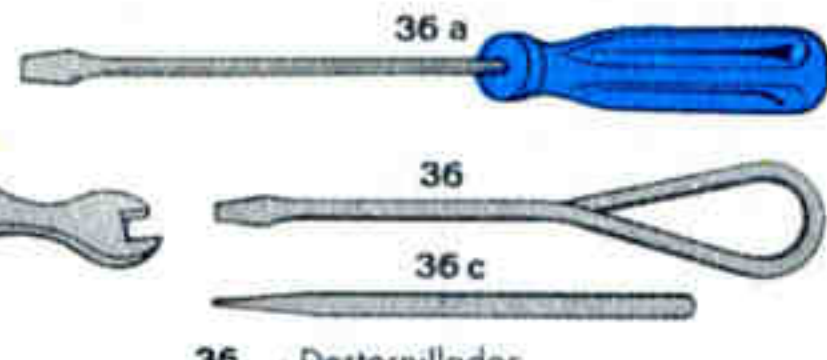

36a

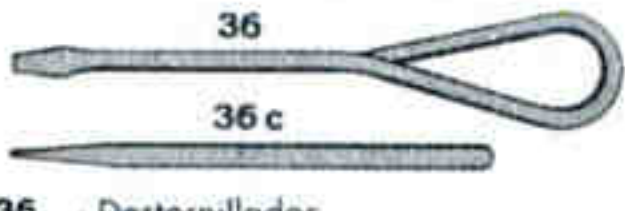

36c

- 36 - Destornillador
- 36a - Destornillador con puño plast.
- 36c - Varilla afilada (puzón).



37a

37b

37c

37d

- 37a - Tuerca
- 37b - Tornillo 6 mm.
- 37c - Tornillo 5 mm.
- 38 - Arandela 10 mm. Ø
- 38d - Arandela 19 mm. Ø

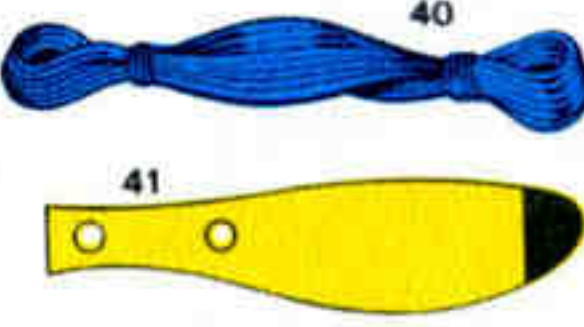

40

- 40 - Ovillo cuerda Metaling
- 41 - Pala de hélice

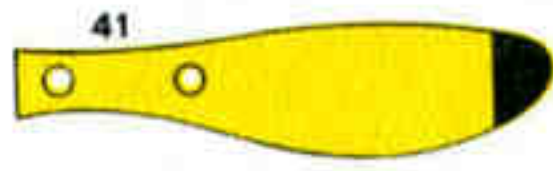

41

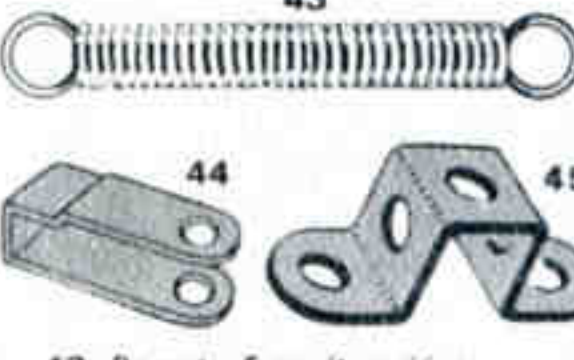

43

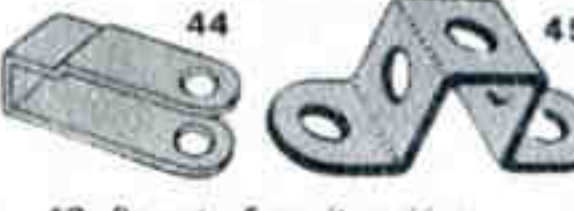

44

- 43 - Resorte 5 cm (tracción).
- 44 - Tira doblada sin horquilla
- 45 - Tira doble encorvadura



46

- 46 - 5 x 2 aguj. 60 x 25 mm.
- 47 - 5 x 3 aguj. 60 x 38 mm.
- 47a - 6 x 3 aguj. 75 x 38 mm.
- 48 - 3 x 1 aguj. 38 x 12 mm.



48a

- ### TIRAS DOBLADAS
- 48a - 5 x 1 aguj. 60 x 12 mm.
  - 48b - 7 x 1 aguj. 90 x 12 mm.
  - 48c - 9 x 1 aguj. 115 x 12 mm.
  - 48d - 11 x 1 aguj. 140 x 12 mm.



50

- 50 - Soporte tira (Deslizante)
- 51 - Placa rebordeada 3x5 aguj. 6x4 cm.

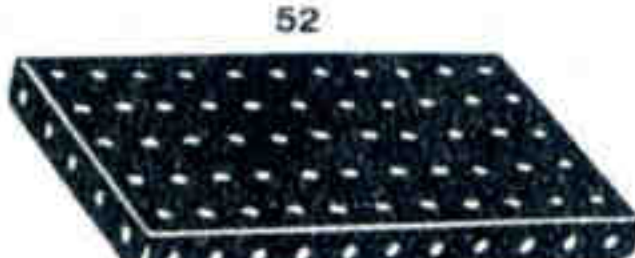

52

- 52 - Placa rebordeada 11x5 aguj. 14x6 cm.
- 53 - Placa rebordeada 7x5 aguj. 9x6 cm.

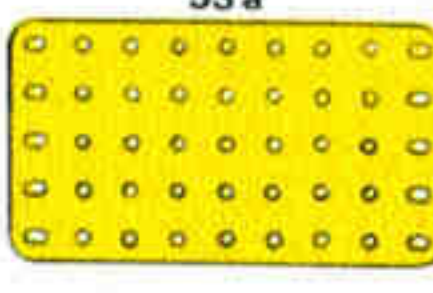

53a

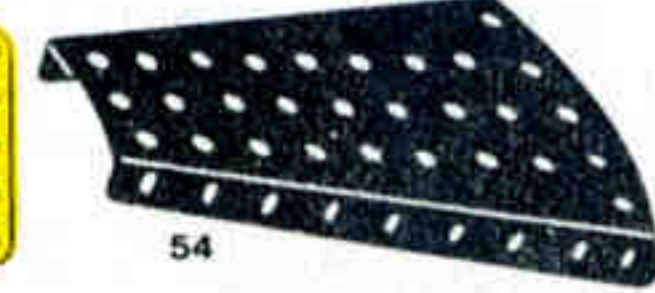

54

- 52a - Placa plana 11 x 7 aguj. 14 x 9 cm.
- 53a - Placa plana 9 x 5 aguj. 11,5 x 6 cm.
- 54 - Placa rebordeada sector 11,5 cm.
- 55a - Tira con muesca 5 cm.

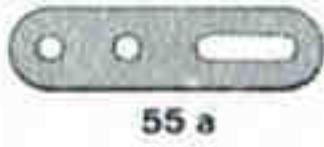

55a

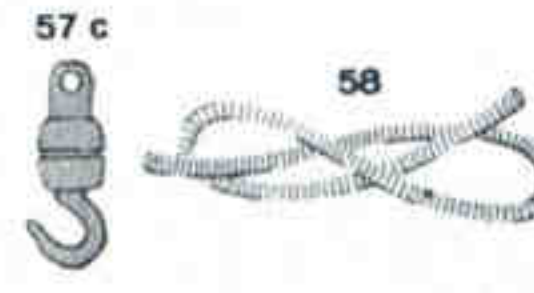

57c



58



59

- 57c - Gancho cargado
- 57d - Gancho
- 58 - Cuerda resorte (1 metro)
- 59 - Collar de fijación (bujé)

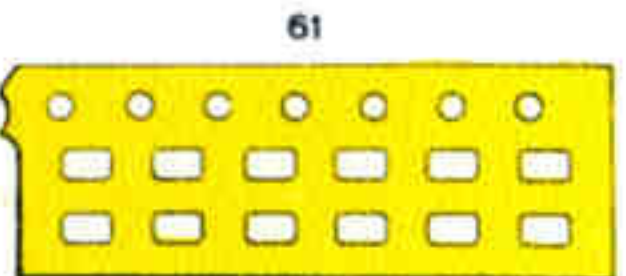

61

61 - Aspa molino

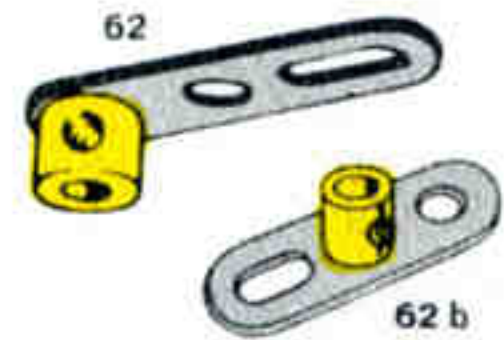

62

- 62 - Cigüeña
- 62a - Cigüeña roscada
- 62b - Cigüeña con buje central

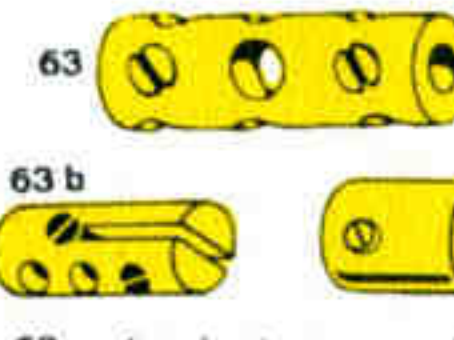

63b

- 63 - Acoplamiento para ejes
- 63b - Acoplamiento ejes y tiras
- 63c - Acoplamiento roscado
- 64 - Bujé roscado



65

- 65 - Horquilla centrajé
- 69 - Tornillo invisible

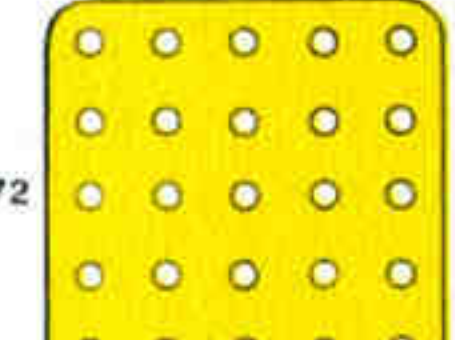

70

- 70 - Placa plana 11x5 aguj. 14x6 cm.
- 72 - Placa plana 5x5 aguj. 6x6 cm.

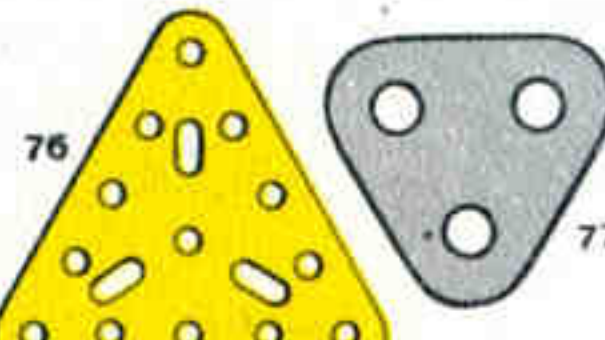

76

- 76 - Placa triangular 5 aguj. 6 cm.
- 77 - Placa triangular 2 aguj. 2,5 cm.



78

- ### VARILLA ROSCADA
- 78 - 29 cm.
  - 79 - 20 cm.
  - 79a - 15 cm.
  - 80 - 12,5 cm.
  - 80a - 9 cm.
  - 80b - 11,5 cm.
  - 80c - 7,5 cm.
  - 81 - 5 cm.
  - 82 - 2,5 cm.

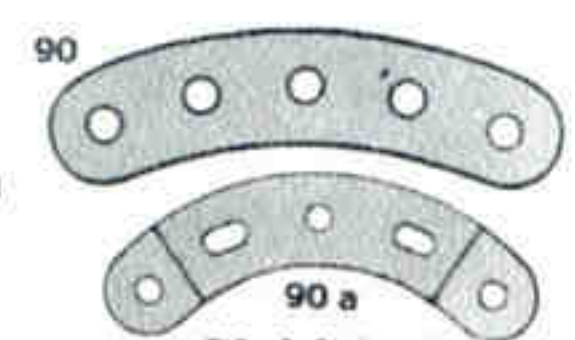

90a

- ### TIRAS CURVAS
- 89 - 11 agujeros
  - 90 - 5 agujeros (gran radio)
  - 90a - 5 agujeros (peq. radio)

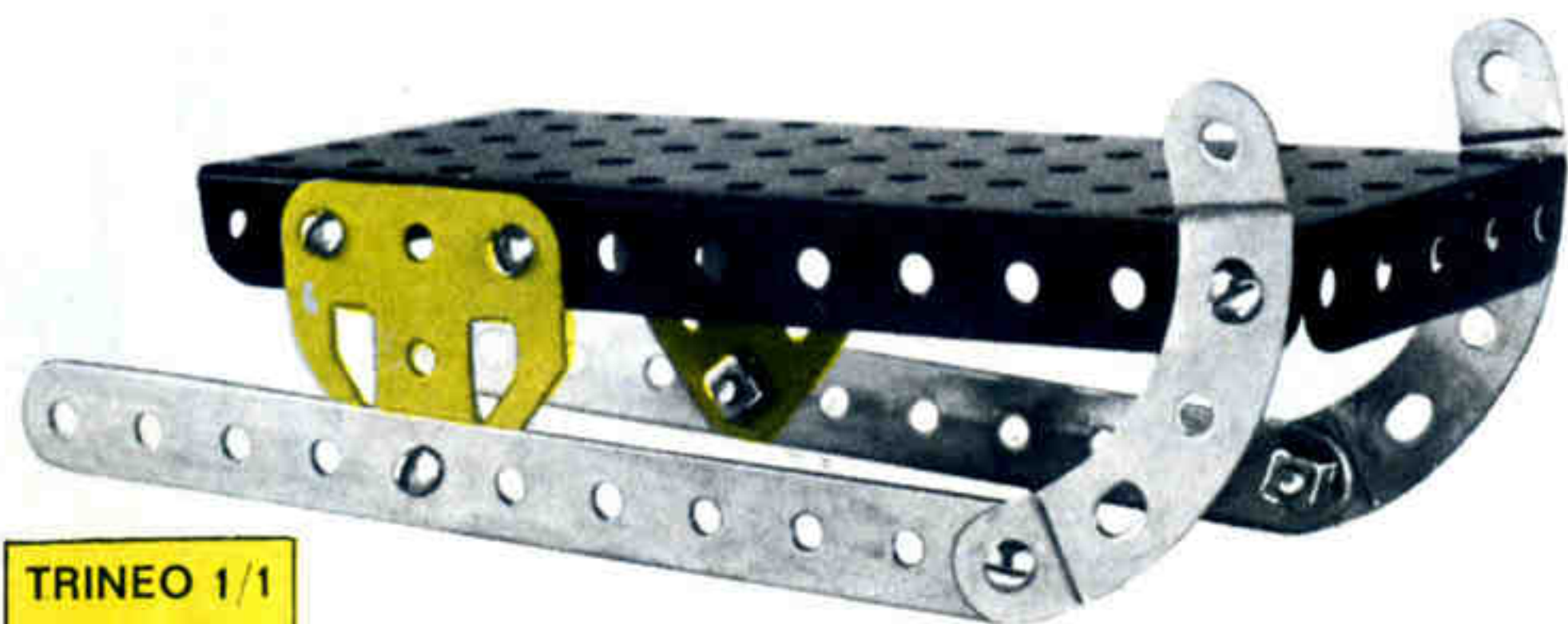

**TRINEO 1/1**  
 2 - 2  
 10 - 37B  
 10 - 37A  
 1 - 52  
 2 - 90A  
 2 - 126A

1  
 Sledge  
 Traîneau  
 Slitta  
 Schitten  
 Trenó

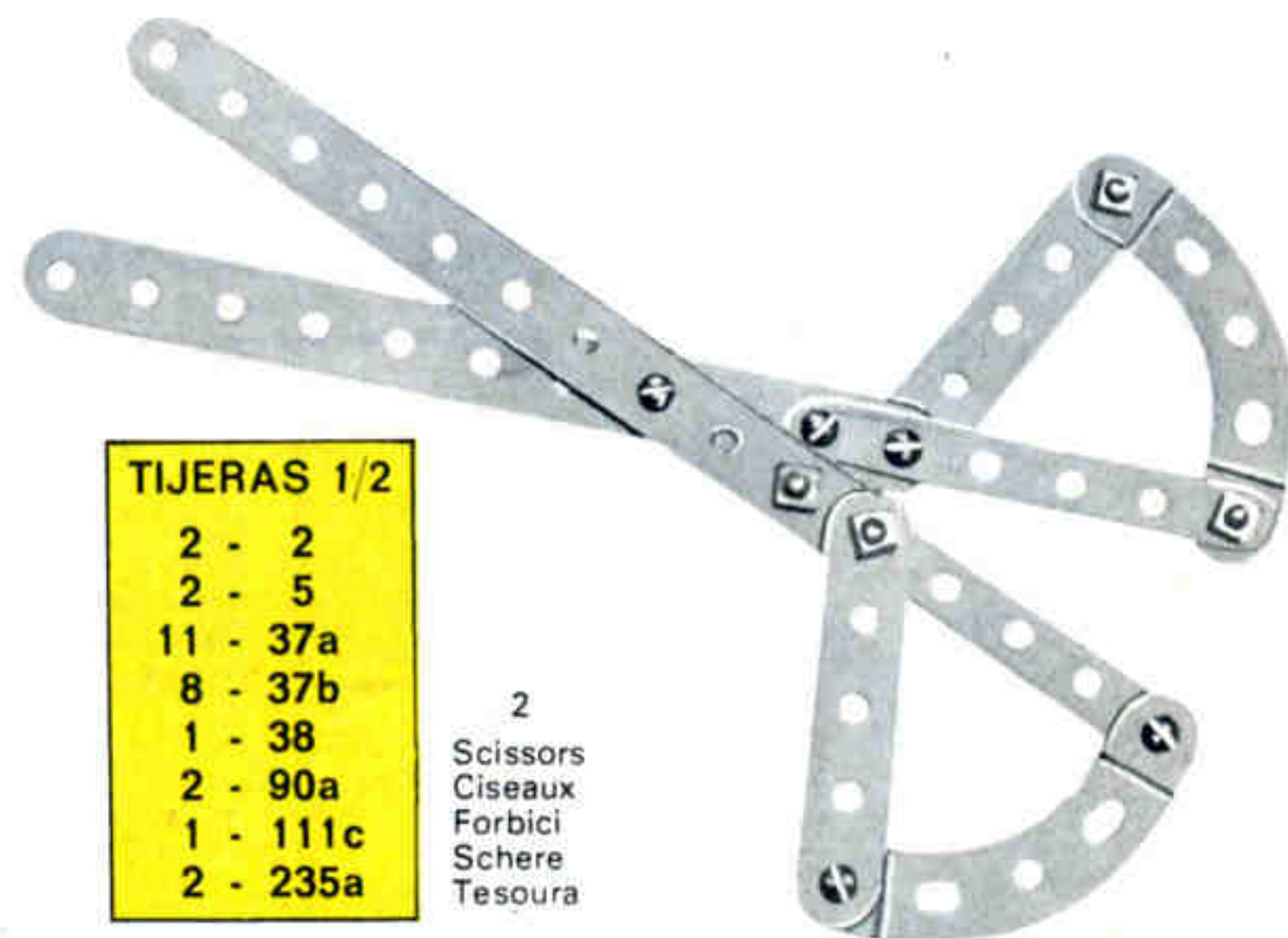

**TIJERAS 1/2**  
 2 - 2  
 2 - 5  
 11 - 37a  
 8 - 37b  
 1 - 38  
 2 - 90a  
 1 - 111c  
 2 - 235a

2  
 Scissors  
 Ciseaux  
 Forbici  
 Schere  
 Tesoura

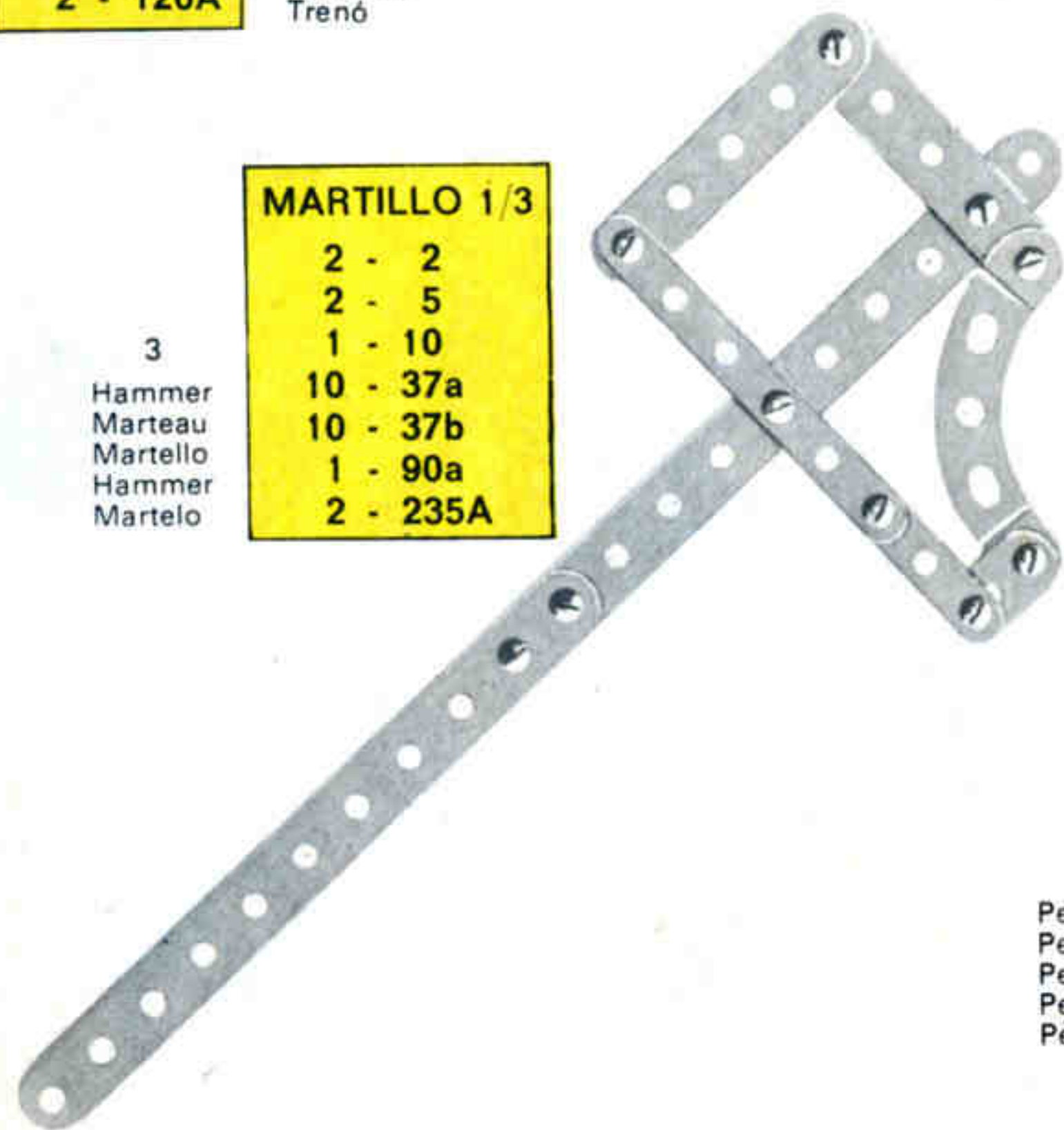

**MARTILLO 1/3**  
 2 - 2  
 2 - 5  
 1 - 10  
 10 - 37a  
 10 - 37b  
 1 - 90a  
 2 - 235A

3  
 Hammer  
 Marteau  
 Martello  
 Hammer  
 Martelo



**PENDULO 1/4**  
 1 - 2  
 1 - 10  
 2 - 12  
 2 - 22  
 1 - 18B  
 9 - 37a  
 7 - 37b  
 1 - 52  
 1 - 111c  
 1 - 126a  
 1 - 235a

Pendulum  
 Pendule  
 Pendolo  
 Pendel  
 Pêndulo



**SILLA 1/5**  
 2 - 2  
 2 - 5  
 2 - 12  
 16 - 37a  
 16 - 37b  
 2 - 48a  
 2 - 194  
 2 - 235a

5  
 Chair  
 Chaise  
 Sedia  
 Stuhl  
 Cadeira



**PARRILLA 1/6**  
 1 - 2  
 6 - 37a  
 6 - 37b  
 2 - 48a  
 3 - 235a

6  
 Grill  
 Grill  
 Graticola  
 Ofenrost  
 Grelha



**HACHA 1/7**  
 8 - 37b  
 8 - 37a  
 2 - 2  
 2 - 235a  
 1 - 9a  
 1 - 10

7  
 Axe  
 Hâche  
 Accetta  
 Axt  
 Machado

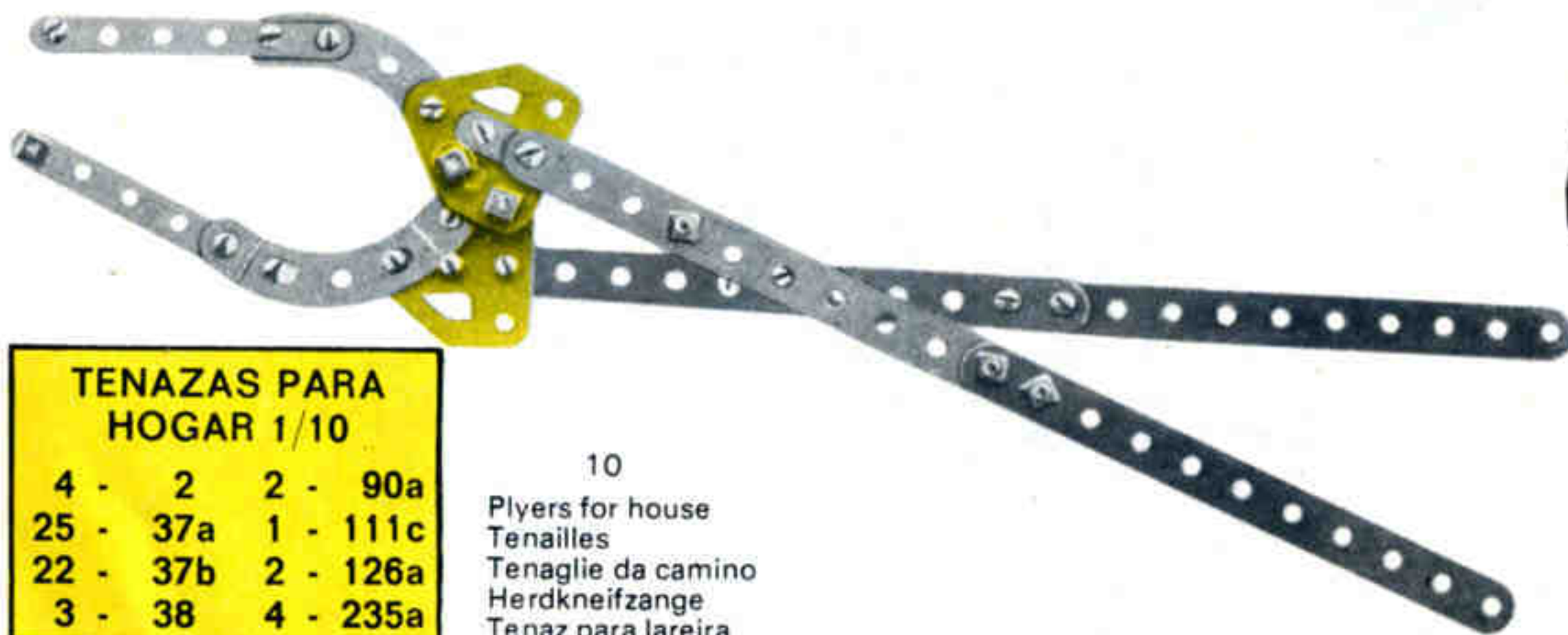

**TENAZAS PARA HOGAR 1/10**  
 4 - 2    2 - 90a  
 25 - 37a    1 - 111c  
 22 - 37b    2 - 126a  
 3 - 38    4 - 235a

10  
 Pliers for house  
 Tenailles  
 Tenaglie da camino  
 Herdkneifzange  
 Tenaz para lareira

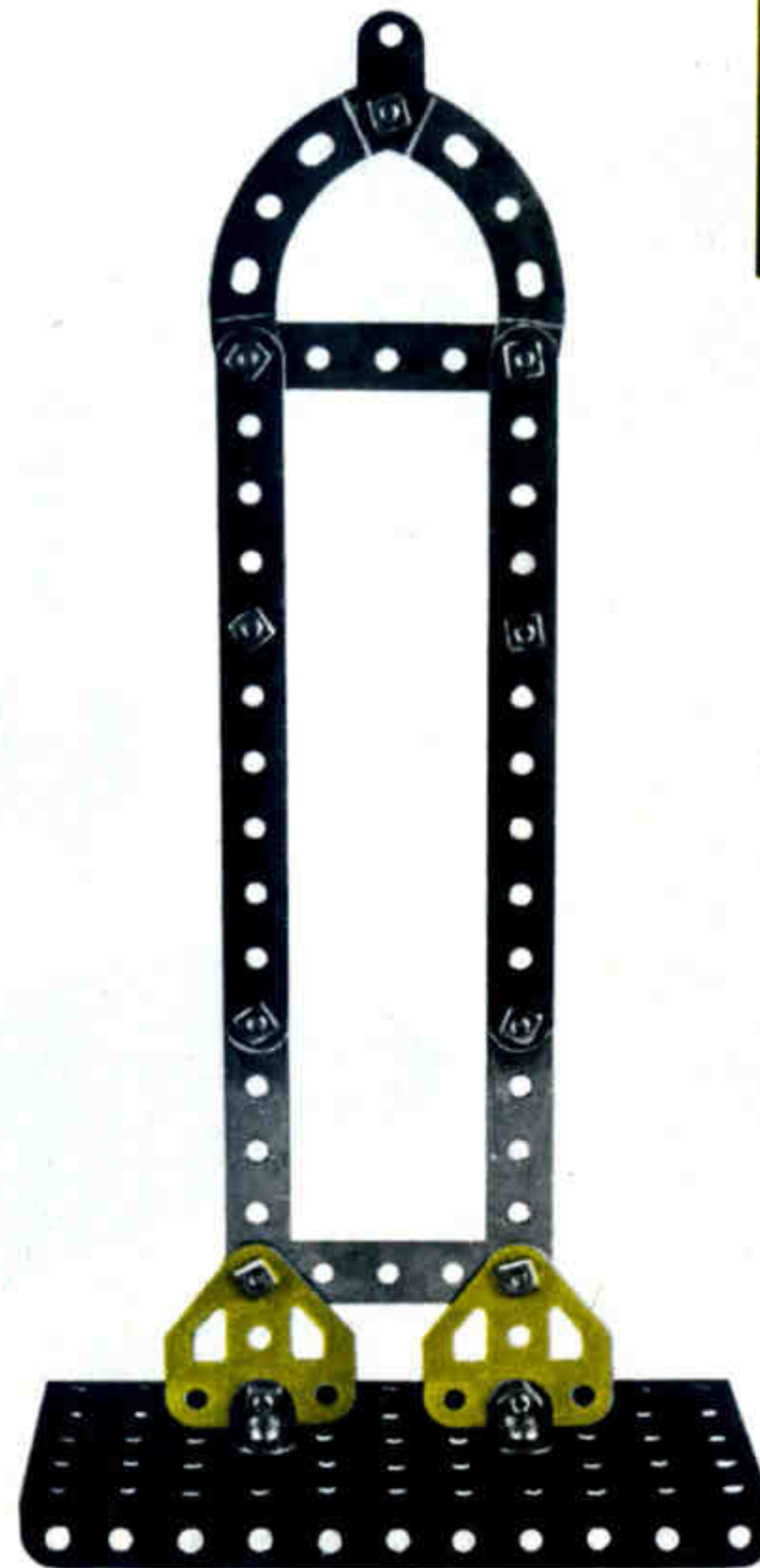

**PERFIL DE COHETE /8**  
 4 - 2    13 - 37b  
 2 - 5    1 - 52  
 1 - 10    2 - 90a  
 2 - 12    2 - 126a  
 13 - 37a

8  
 Profile of a rocket  
 Profil de fusée  
 Profilo di razzo  
 Raketenprofil  
 Perfil de foguete

**LAMPARA 1/9**  
 2 - 2  
 1 - 11  
 2 - 12  
 14 - 37a  
 14 - 37b  
 1 - 48a  
 2 - 126  
 2 - 193  
 2 - 194

9  
 Lamp  
 Lampe  
 Lampada  
 Lampe  
 Candeeiro

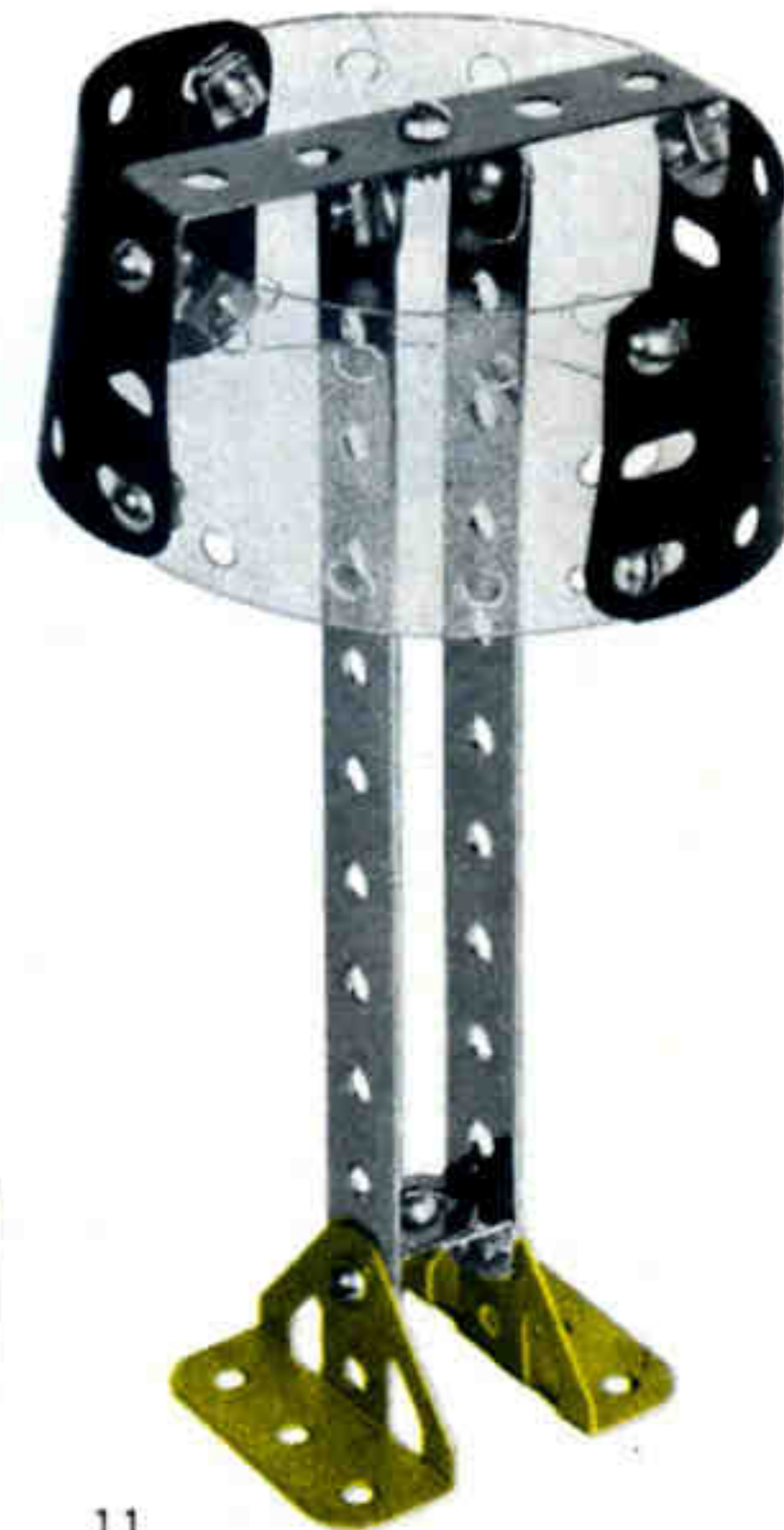

**ANCLA 1/11**  
 1 - 2  
 1 - 5  
 1 - 22  
 4 - 37a  
 4 - 37b  
 2 - 90a  
 1 - 111c  
 2 - 126a

11  
 Anchor  
 Ancre  
 Ancora  
 Anker  
 Ancora



**HORCA /12**  
 2 - 2  
 2 - 5  
 7 - 37a  
 7 - 37b  
 2 - 90a  
 2 - 235a

12  
 Fork  
 Fourche  
 Forca  
 Gabel  
 Forquilha

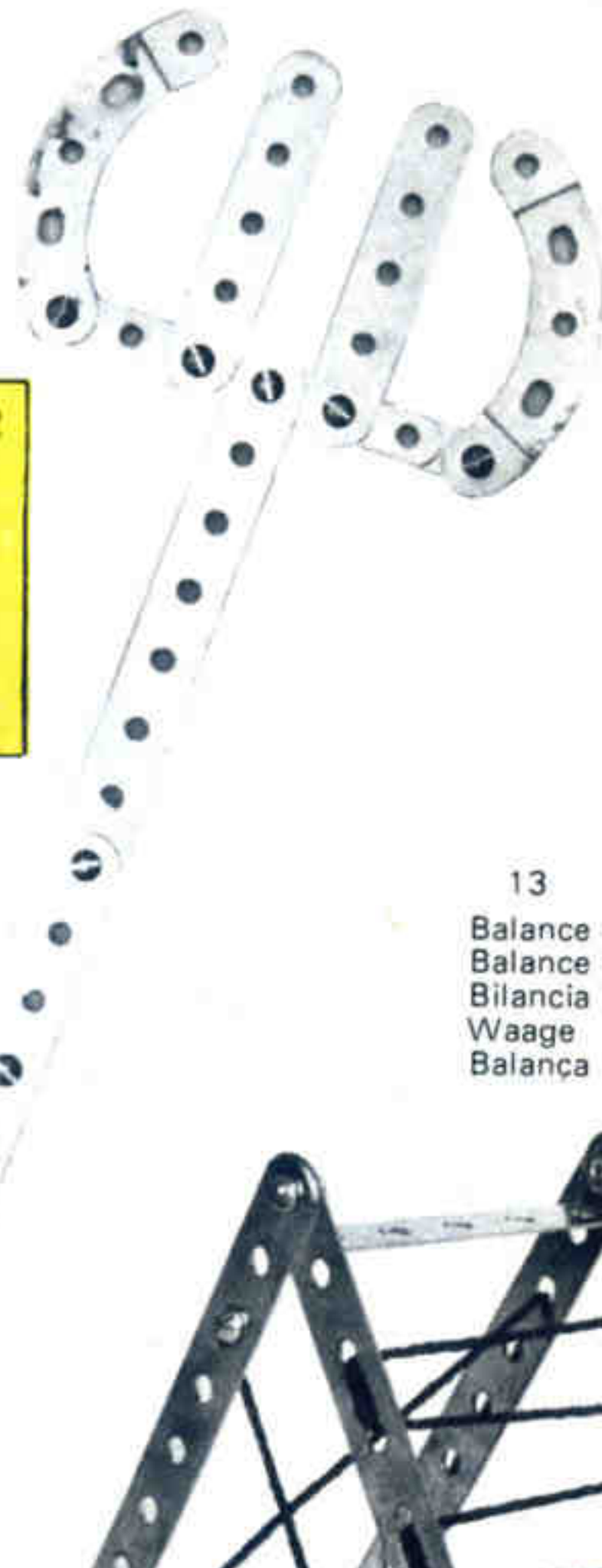

**BALANZA 1/13**  
 4 - 2  
 1 - 18b  
 2 - 35  
 16 - 37b  
 20 - 37a  
 4 - 38  
 1 - 52  
 2 - 90a  
 2 - 111c  
 2 - 126  
 2 - 235a

13  
 Balance  
 Balance  
 Bilancia  
 Waage  
 Balança

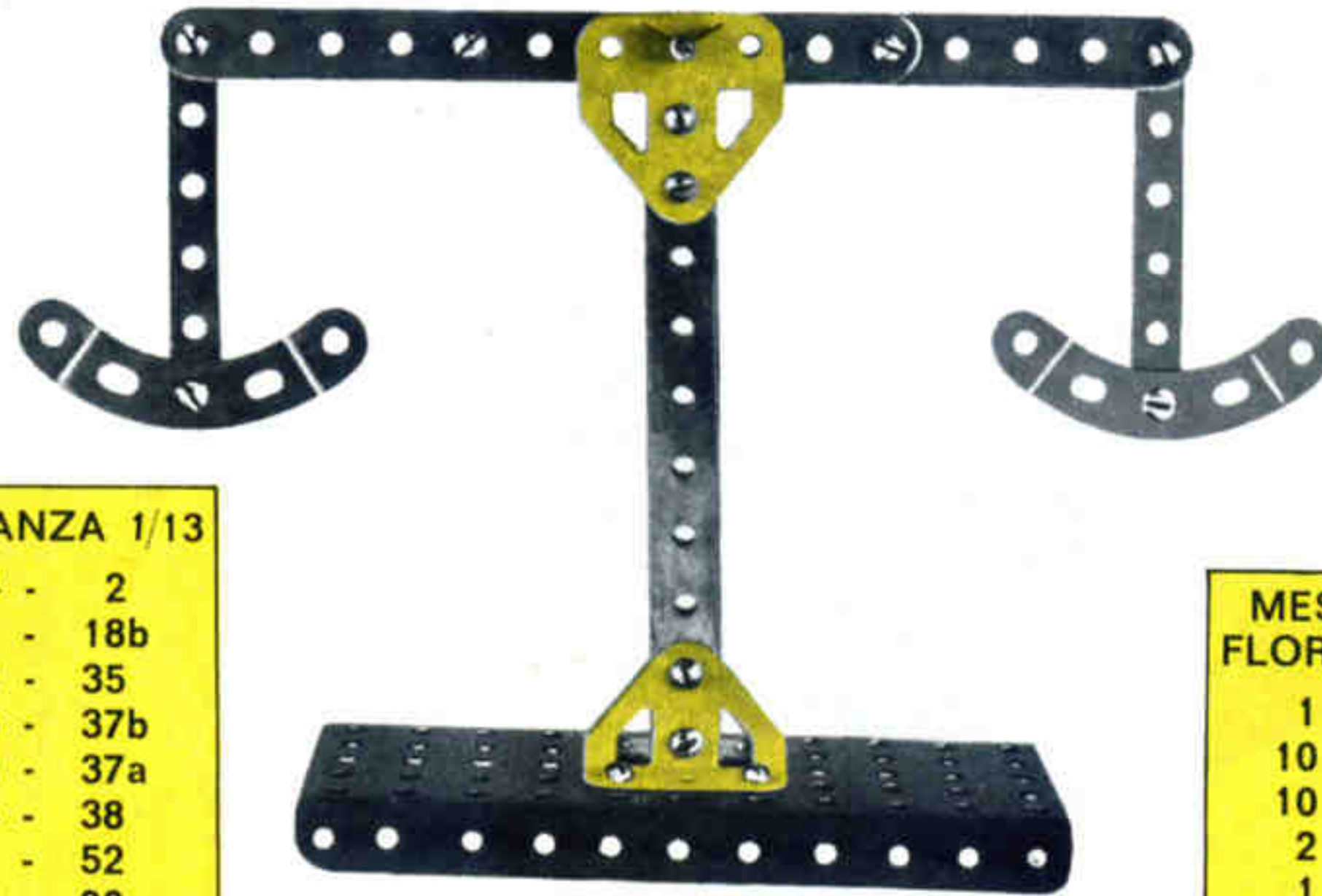

**MESA CON FLOREIRO 1/14**  
 1 - 24  
 10 - 37a  
 10 - 37b  
 2 - 48a  
 1 - 52  
 1 - 111c

14  
 Table with flower-pot  
 Table avec pot de fleurs  
 Tavolo con vaso da fiori  
 Tisch mit Vase  
 Mesa com floreira



**ESCALERA /15**  
 4 - 2  
 1 - 5  
 2 - 12  
 12 - 37a  
 12 - 37b  
 2 - 48a

15  
 Ladder  
 Echelle  
 Scala  
 Treppe  
 Escada



16  
 Boat  
 Bateau  
 Barca  
 Faehre  
 Barca

**BARCA 1/16**  
 4 - 2  
 1 - 10  
 1 - 19s  
 1 - 24  
 2 - 35  
 17 - 37a  
 17 - 37b  
 1 - 38  
 2 - 48a  
 1 - 90a  
 1 - 194  
 3 - 235a

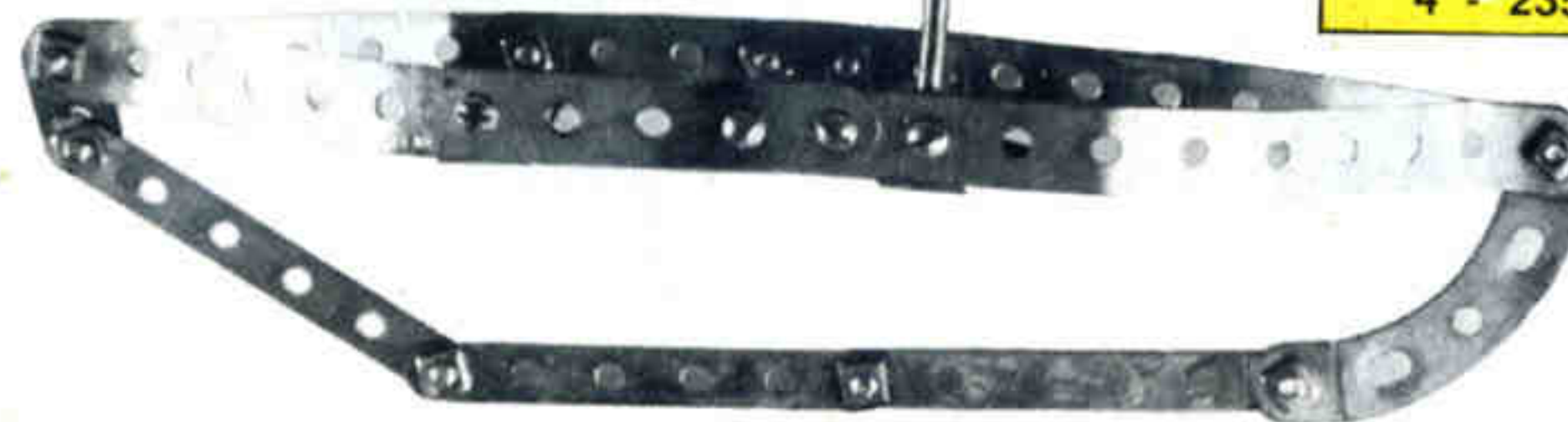

17  
 Windmill  
 Moulin à vent  
 Mulino  
 Muehle  
 Moinho

**MOLINO 1/17**  
 4 - 2  
 2 - 5  
 2 - 10  
 2 - 12  
 1 - 24  
 23 - 37b  
 25 - 37a  
 2 - 48a  
 2 - 111c  
 2 - 126  
 2 - 126a  
 2 - 193  
 1 - 194  
 4 - 235a





**POSTE TENDIDO ELECTRICO 1/18**  
 4 - 2  
 1 - 11  
 2 - 12  
 25 - 37a  
 25 - 37b  
 1 - 48a  
 2 - 90a  
 2 - 126  
 2 - 235a

18  
 Electric pole  
 Poteau électrique  
 Palo rete elettrica  
 Telegraphenmast  
 Poste eléctrico



**CAMA 1/19**  
 2 - 5  
 8 - 37a  
 8 - 37b  
 1 - 52  
 2 - 90a  
 3 - 235a

19  
 Bed  
 Lit  
 Letto  
 Bett  
 Cama



**BALANCIN 1/21**  
 2 - 2  
 1 - 11  
 2 - 12  
 1 - 18b  
 2 - 35  
 11 - 37a  
 11 - 37b  
 1 - 52  
 2 - 126  
 2 - 126a

21  
 Swing  
 Balançoire  
 Dondolona  
 Wippe  
 Balancé

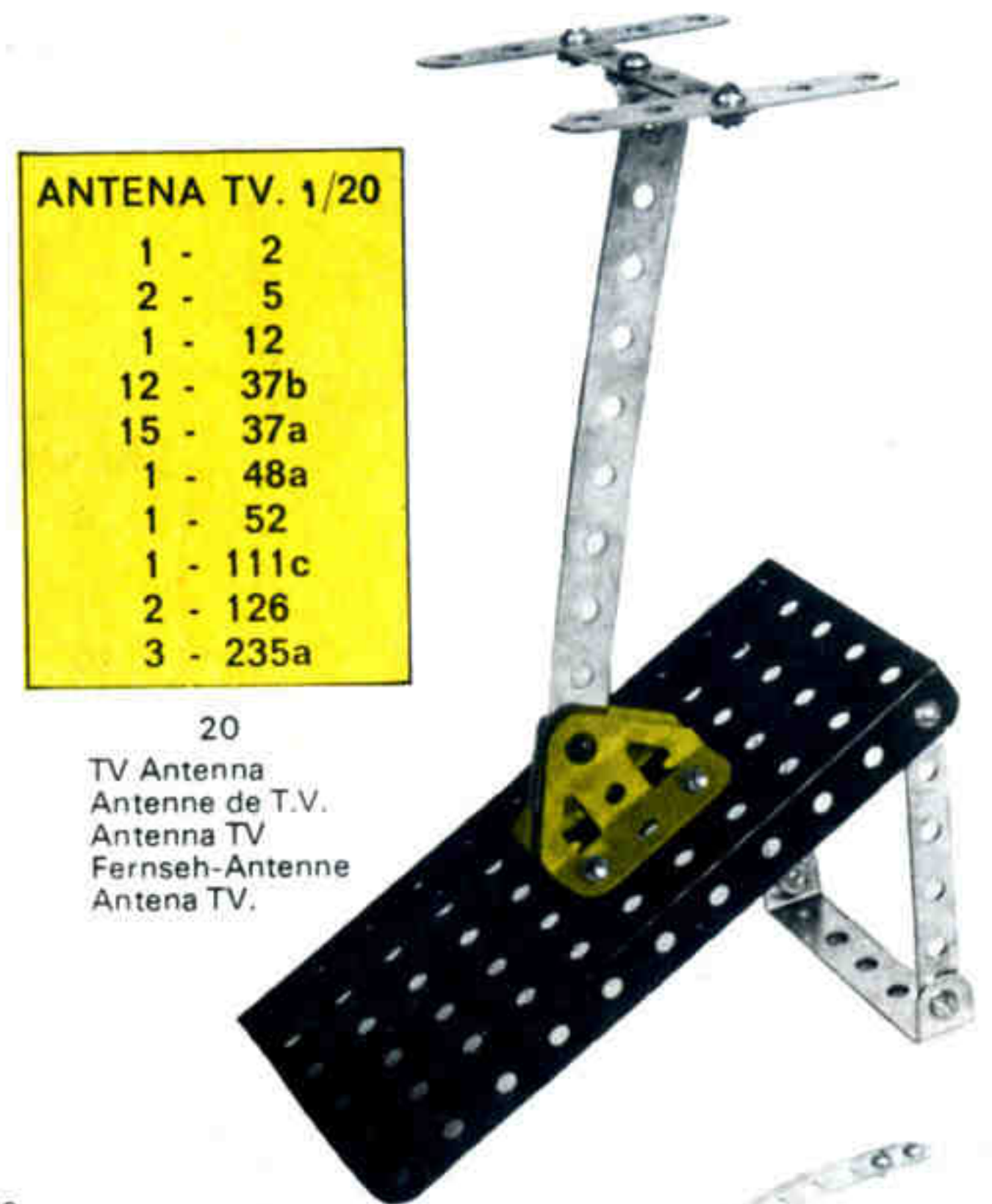

**ANTENA TV. 1/20**  
 1 - 2  
 2 - 5  
 1 - 12  
 12 - 37b  
 15 - 37a  
 1 - 48a  
 1 - 52  
 1 - 111c  
 2 - 126  
 3 - 235a

20  
 TV Antenna  
 Antenne de T.V.  
 Antenna TV  
 Fernseh-Antenne  
 Antena TV.

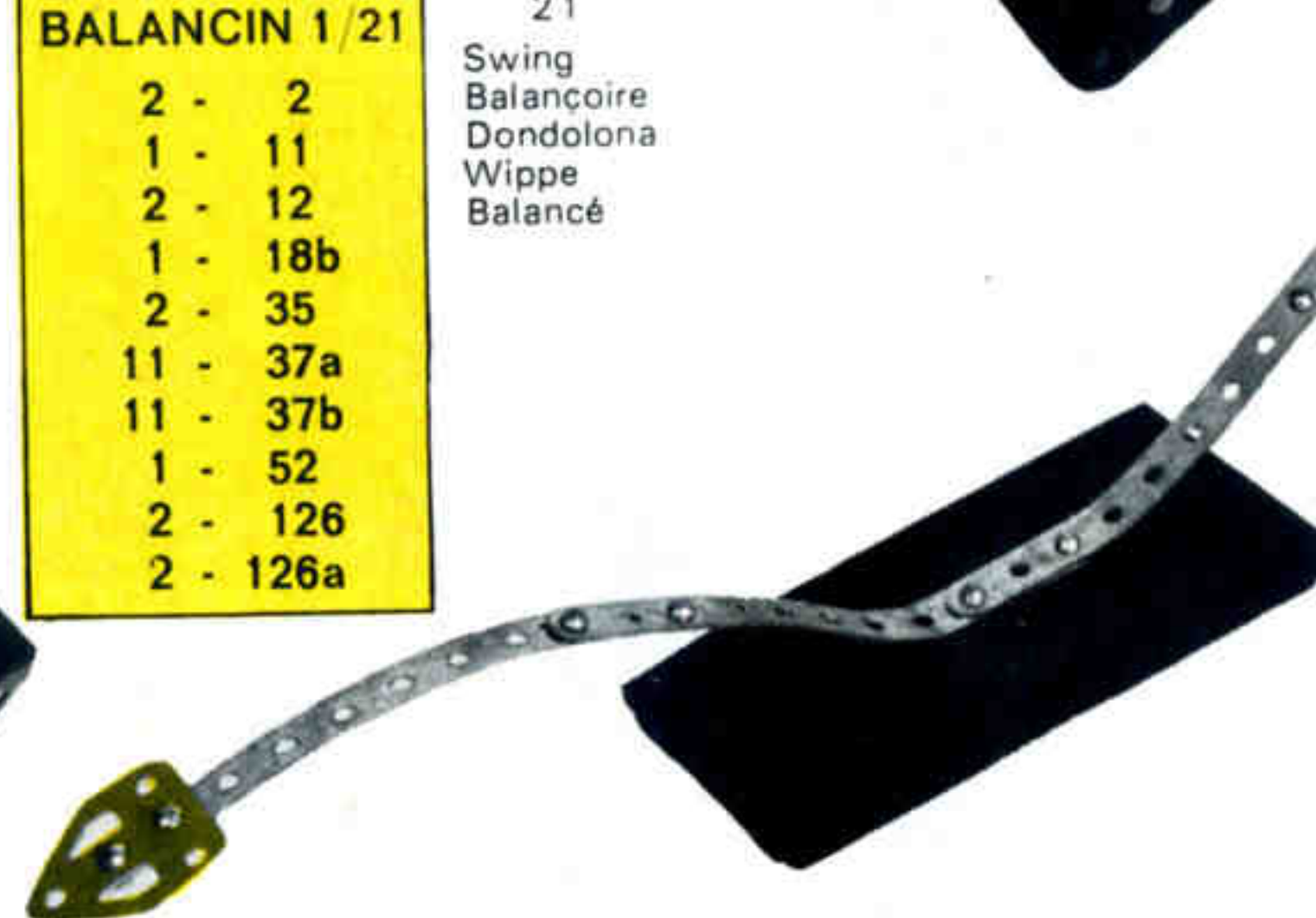

**SERPIENTE 1/22**  
 4 - 2  
 10 - 37a  
 10 - 37b  
 1 - 52  
 1 - 126a

22  
 Snake  
 Serpent  
 Serpente  
 Schlange  
 Serpente

**COLUMPIO 1/23**

- 4 - 2
- 2 - 5
- 19 - 37a
- 19 - 37b
- 1 - 40
- 2 - 48a
- 1 - 52
- 1 - 90a
- 2 - 126
- 4 - 235a

23

Seesaw  
Balancoire  
Altalena  
Schaukel  
Baloço



24  
Weight-lifter  
Haltérophile  
Forzuto  
Geruest  
Forçudo

**FORZUDO 1/24**

- 2 - 5
- 2 - 12
- 1 - 16
- 2 - 22
- 1 - 24
- 11 - 37a
- 11 - 37b
- 1 - 48a
- 1 - 52
- 1 - 111c
- 1 - 126a
- 2 - 142c
- 3 - 235a

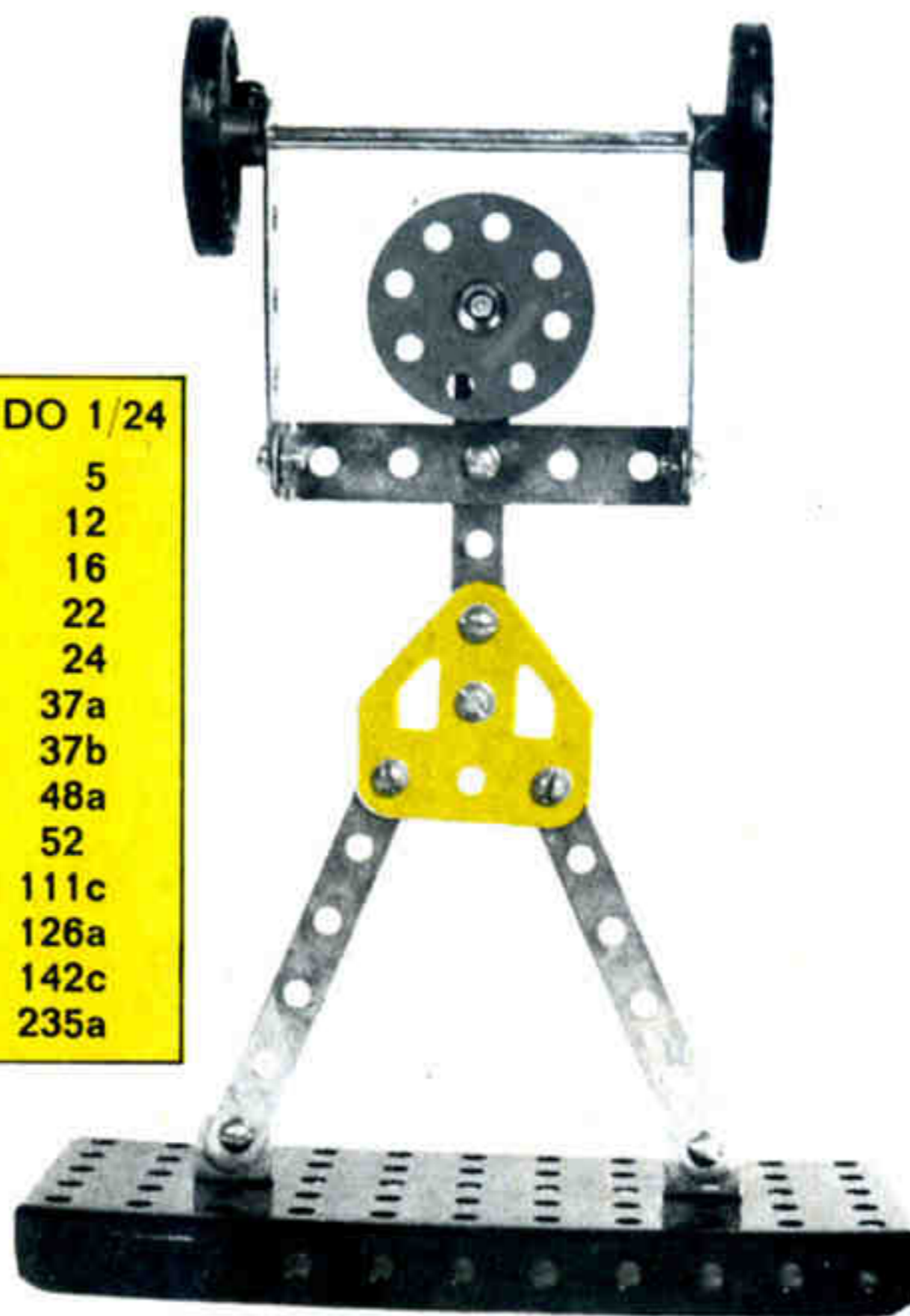

25

Tennis chair  
Siège tennis  
Sedia da tennis  
Tennis stuhl  
Cadeira de ténis

**SILLA DE TENIS 1/25**

- 4 - 2
- 2 - 5
- 4 - 12
- 1 - 16
- 2 - 35
- 24 - 37a
- 24 - 37b
- 2 - 38
- 2 - 48a
- 1 - 52
- 2 - 90a
- 2 - 126
- 2 - 194
- 2 - 235



**RELOJ 1/26**

- 2 - 12
- 23 - 37a
- 19 - 37b
- 1 - 38
- 1 - 52
- 2 - 111c
- 4 - 235a

26

Clock  
Pendule  
Orologio  
Uhr  
Relógio

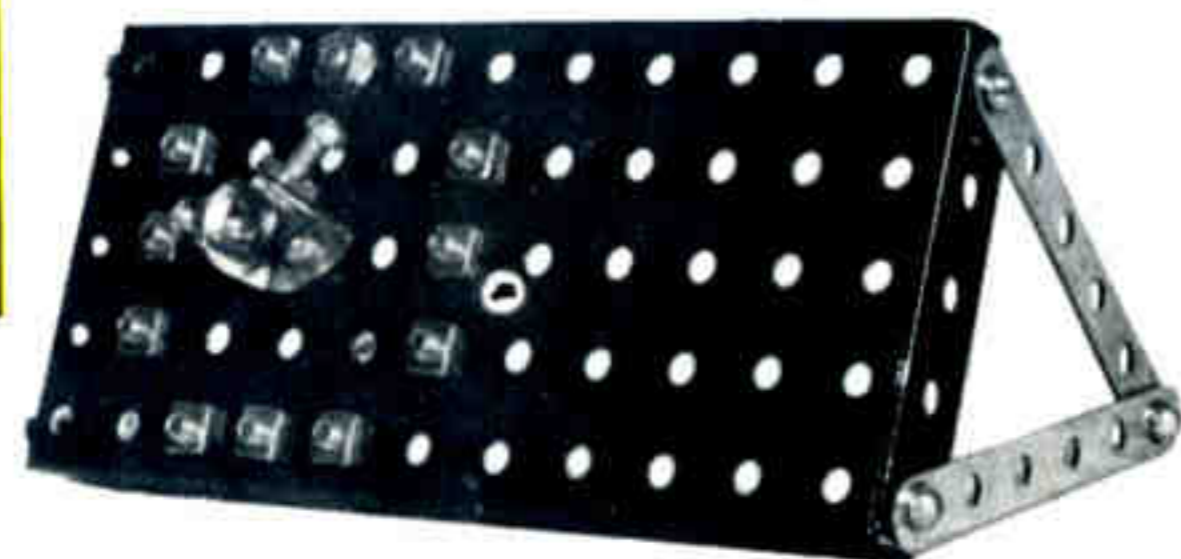

27

Small cannon  
Petit canon  
Cannoncino  
Kleine Kanone  
Canhaozinho

**CAÑONCITO 1/27**

- 2 - 2
- 2 - 35
- 2 - 10
- 8 - 37a
- 1 - 12
- 8 - 37b
- 1 - 16
- 6 - 38
- 2 - 22
- 1 - 48a
- 1 - 195
- 2 - 142c



**PUENTE /29**  
 2 - 2  
 18 - 37a  
 18 - 37b  
 2 - 48a  
 1 - 52  
 2 - 126  
 2 - 126a  
 4 - 235a

29  
 Bridge  
 Pont  
 Ponte  
 Bruecke  
 Ponte

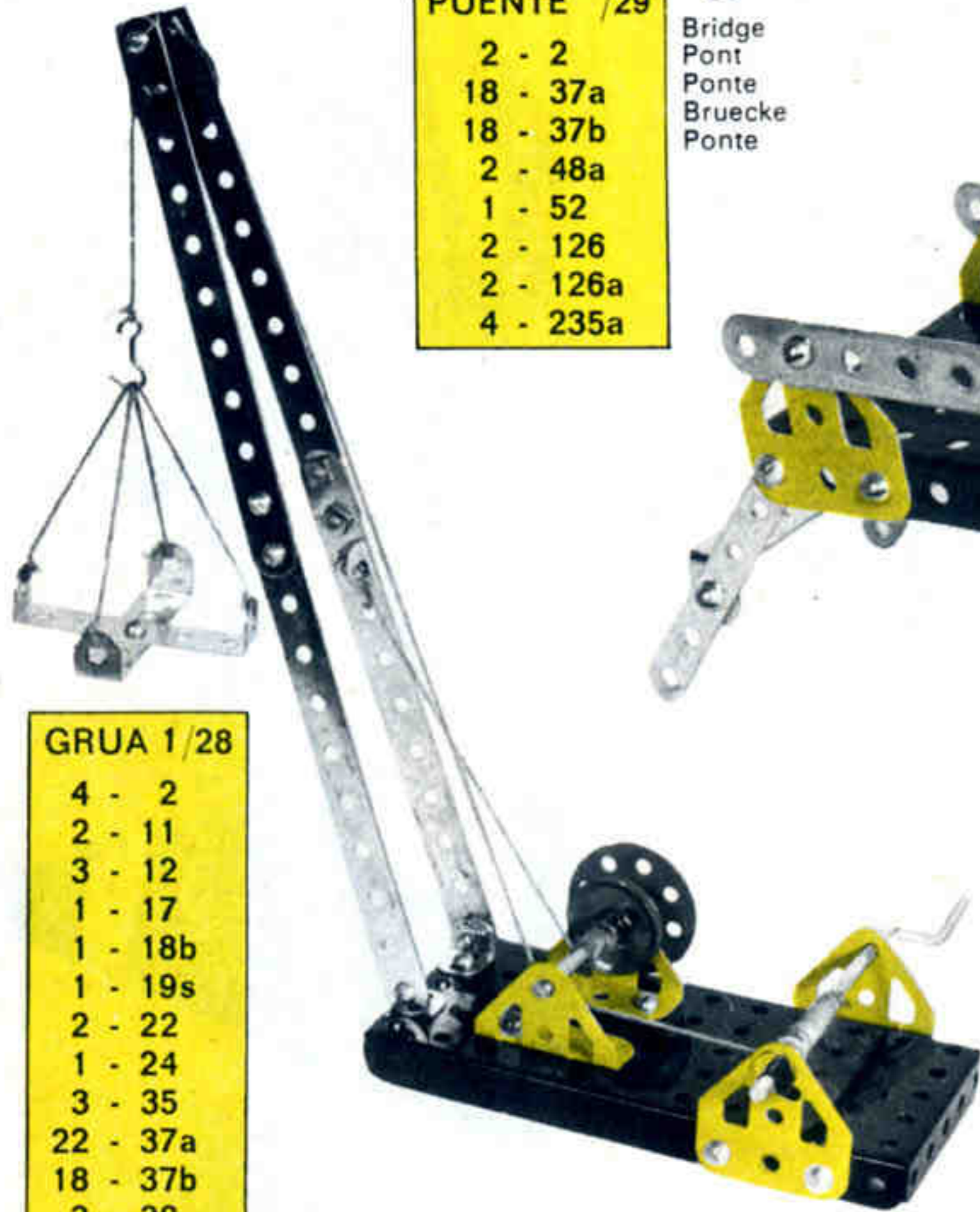

**GRUA 1/28**  
 4 - 2  
 2 - 11  
 3 - 12  
 1 - 17  
 1 - 18b  
 1 - 19s  
 2 - 22  
 1 - 24  
 3 - 35  
 22 - 37a  
 18 - 37b  
 3 - 38  
 2 - 48a  
 1 - 52  
 1 - 57b  
 2 - 111c  
 2 - 126  
 2 - 126a

28  
 Crane  
 Grue  
 Gru  
 Kran  
 Grue

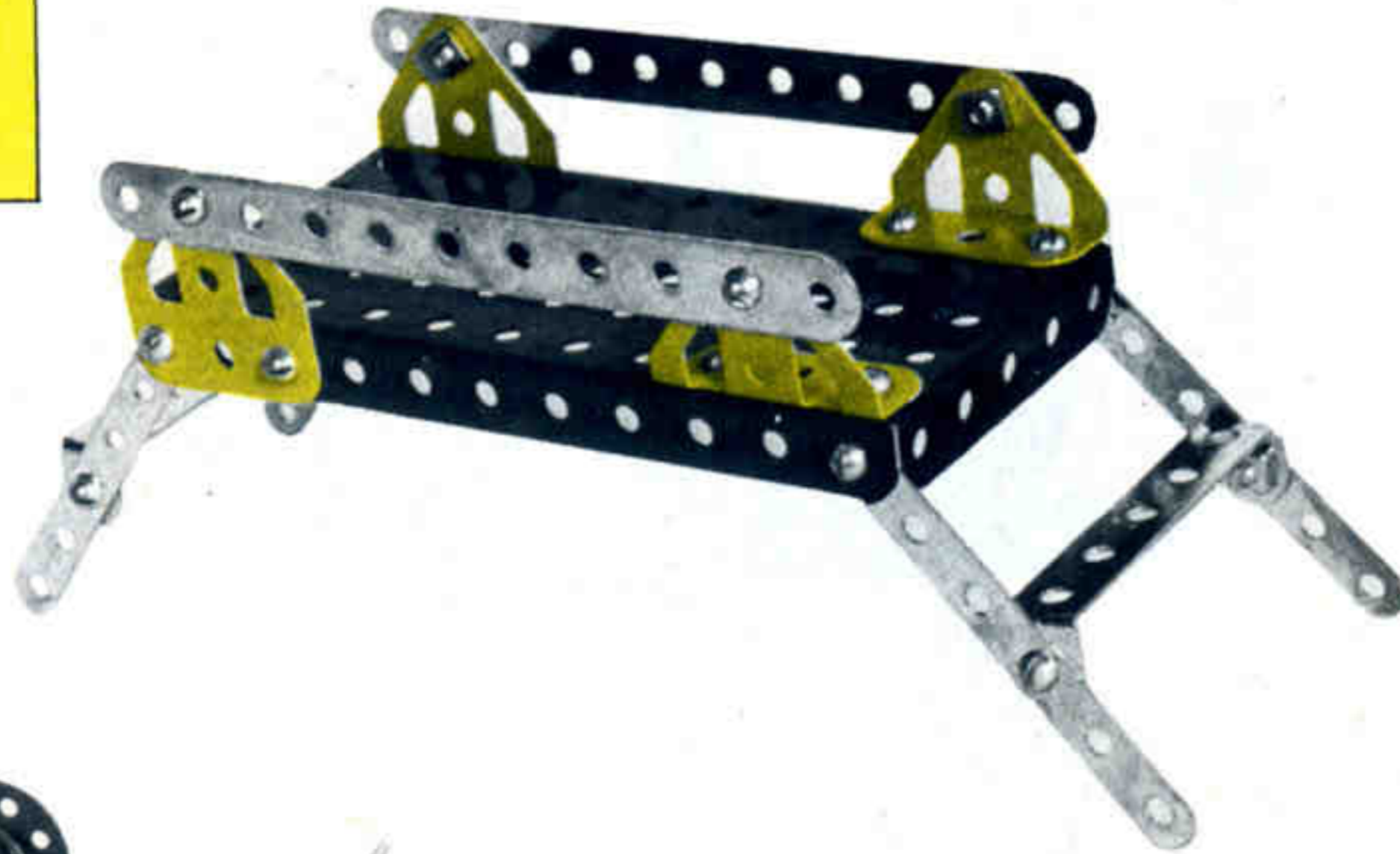

**CARRETILLA 1/31**  
 2 - 10    2 - 126  
 1 - 16    2 - 126a  
 2 - 22    2 - 142c  
 12 - 37a    1 - 194  
 12 - 37b    2 - 235a  
 1 - 52

31  
 Wheel-barrow  
 Brouette  
 Cariola  
 Karren  
 Carretilha

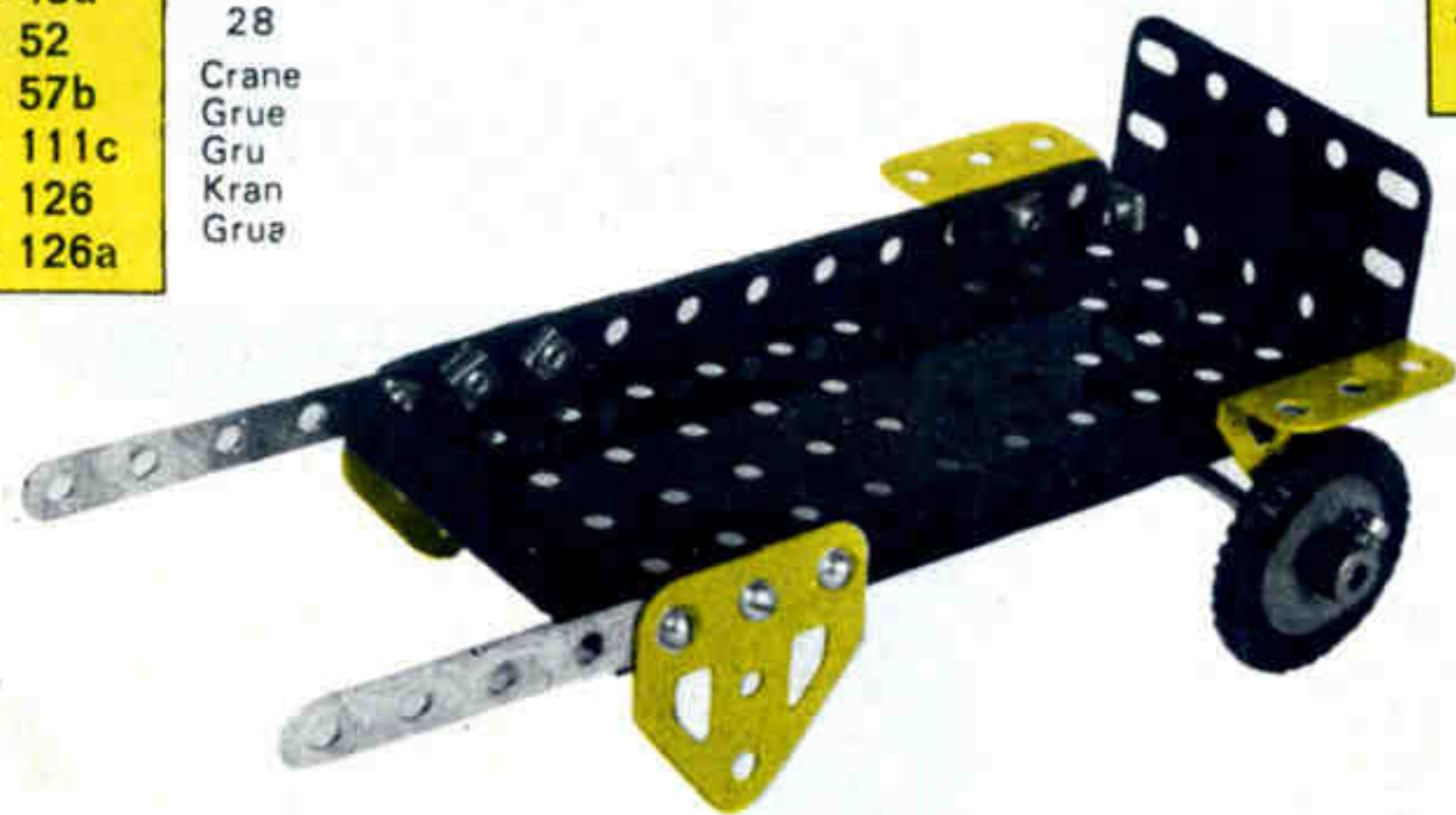

**TRINEO 1/32**  
 4 - 2    2 - 48a  
 1 - 5    1 - 52  
 1 - 10    2 - 90a  
 2 - 12    2 - 111c  
 1 - 22    1 - 193  
 25 - 37a    2 - 194  
 24 - 37b    4 - 235a

32  
 Sledge  
 Traîneau  
 Slitta  
 Schlitten  
 Trenó

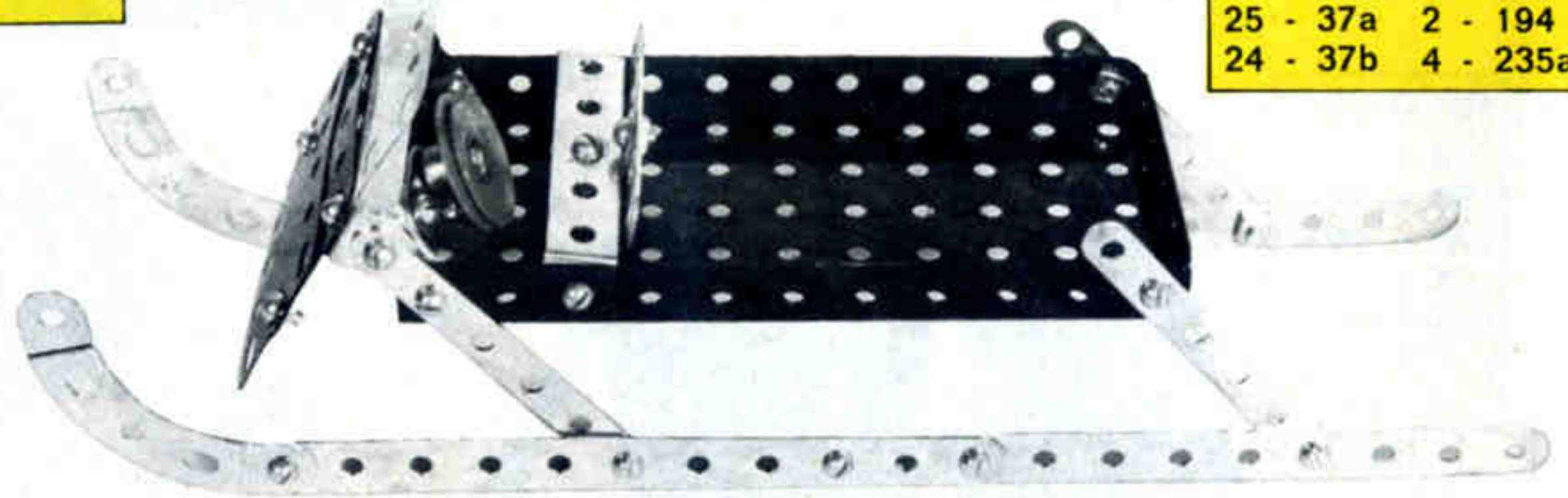

**BANCO DE JARDIN 1/30**  
 2 - 2  
 2 - 5  
 12 - 37a  
 12 - 37b  
 2 - 48a  
 1 - 52  
 4 - 235a

30  
 Park bench  
 Banc de jardin  
 Banco di giardino  
 Gartenbank  
 Banco de jardim







**GRUA 1/33**

|          |          |
|----------|----------|
| 4 - 2    | 20 - 37b |
| 1 - 10   | 4 - 38   |
| 2 - 12   | 1 - 40   |
| 1 - 17   | 2 - 48a  |
| 1 - 18b  | 1 - 52   |
| 1 - 19s  | 1 - 57d  |
| 2 - 22   | 1 - 111c |
| 1 - 24   | 2 - 126  |
| 4 - 35   | 2 - 126a |
| 22 - 37a | 4 - 235a |

33  
Crane  
Grue  
Gru  
Kran  
Grua

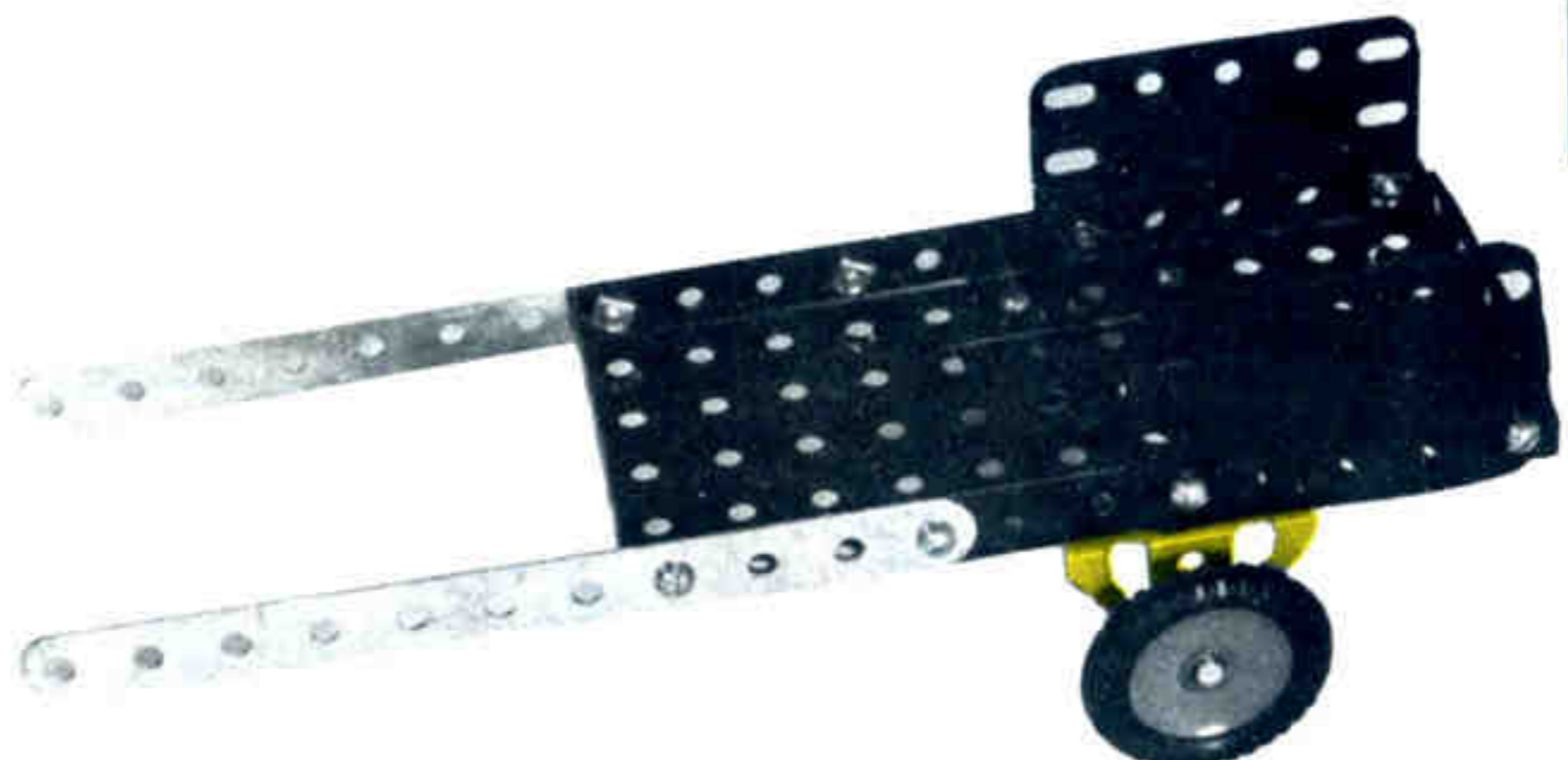

**CARRO 1/34**

|          |
|----------|
| 2 - 2    |
| 1 - 16   |
| 2 - 22   |
| 12 - 37a |
| 12 - 37b |
| 1 - 52   |
| 2 - 126  |
| 2 - 142c |
| 2 - 194  |

34  
Barrow  
Chariot  
Carrello  
Karren  
Carroca

**BALANZA 1/36**

|          |          |
|----------|----------|
| 2 - 2    | 6 - 38   |
| 1 - 11   | 2 - 48a  |
| 4 - 12   | 1 - 52   |
| 1 - 17   | 1 - 90a  |
| 2 - 22   | 1 - 111c |
| 1 - 24   | 2 - 126  |
| 1 - 35   | 2 - 194  |
| 19 - 37a | 2 - 235a |
| 19 - 37b |          |

36  
Scale  
Balance  
Bilancia  
Waage  
Balanza

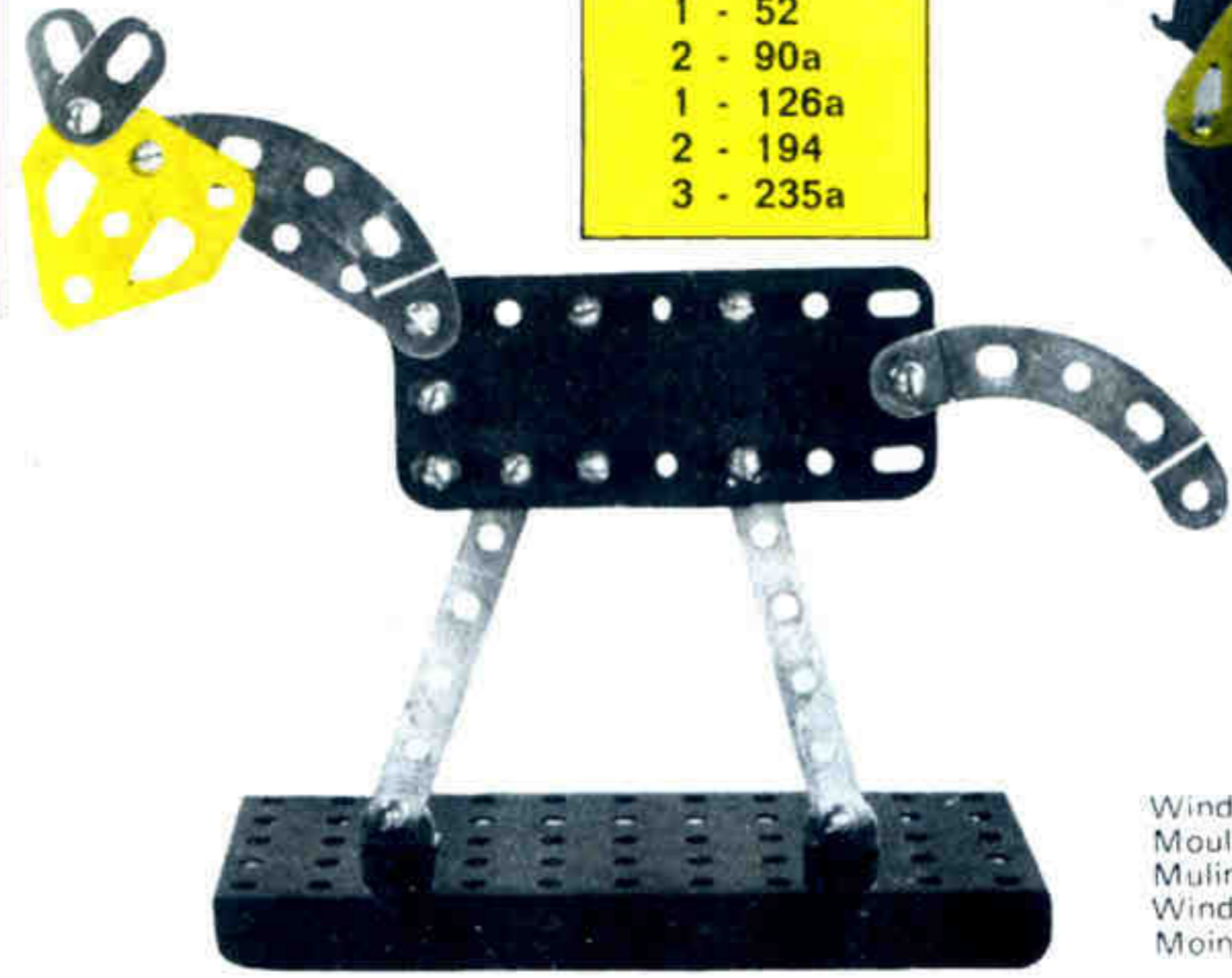
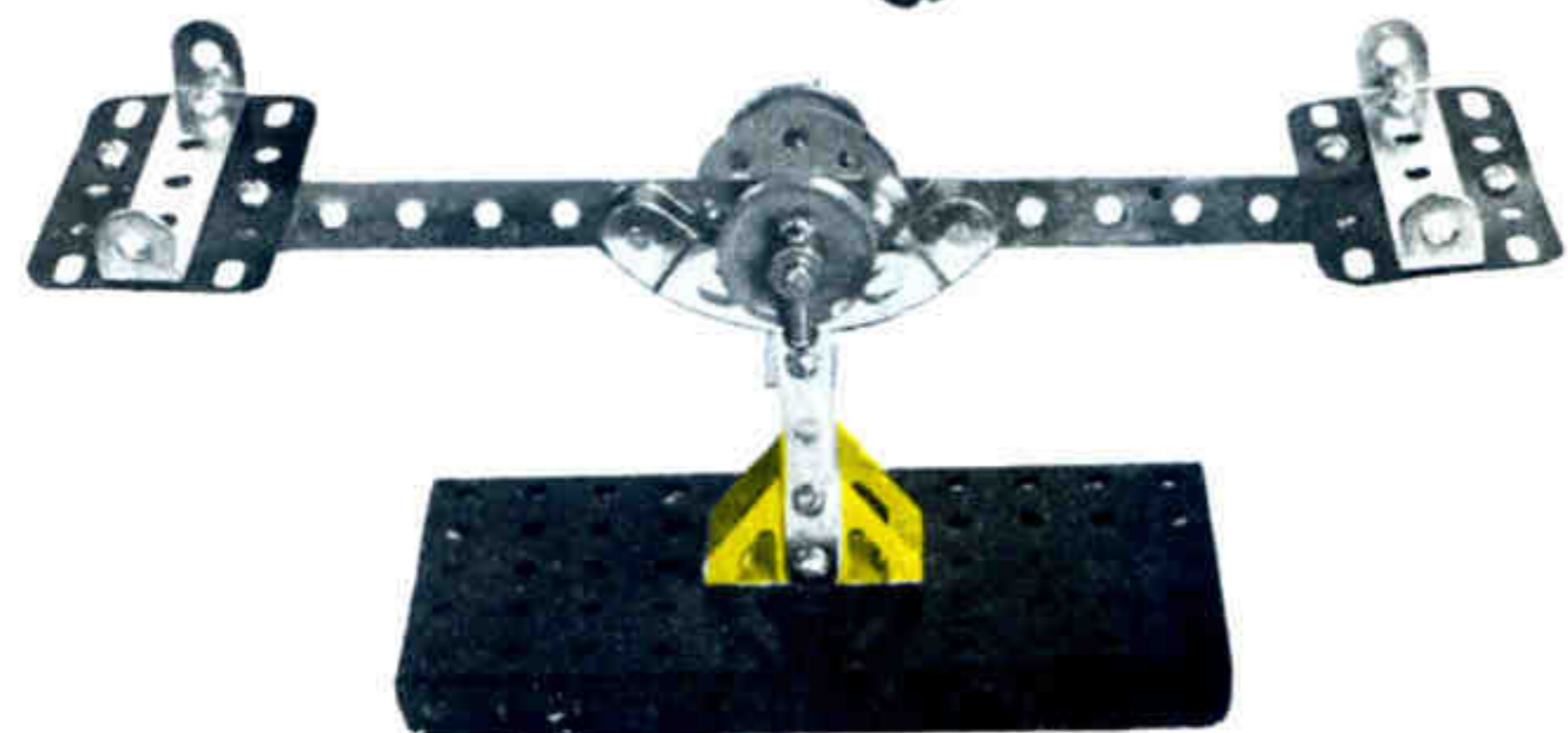

**CABALLO 1/37**

|          |
|----------|
| 1 - 5    |
| 4 - 10   |
| 2 - 12   |
| 15 - 37a |
| 15 - 37b |
| 1 - 52   |
| 2 - 90a  |
| 1 - 126a |
| 2 - 194  |
| 3 - 235a |

37  
Horse  
Cheval  
Cavallo  
Pferd  
Cavalo



**MOLINO DE VIENTO 1/35**

|          |          |
|----------|----------|
| 4 - 2    | 24 - 37b |
| 2 - 5    | 1 - 40   |
| 1 - 16   | 2 - 48a  |
| 1 - 19s  | 1 - 52   |
| 2 - 22   | 2 - 90a  |
| 1 - 24   | 2 - 126  |
| 1 - 35   | 2 - 126a |
| 24 - 37a | 4 - 235a |

35  
Windmill  
Moulin à vent  
Mulino a vento  
Windmuehle  
Moinho de vento

**ESCALERA DE RUEDAS 1/38**

- 4 - 2
- 2 - 5
- 1 - 16
- 2 - 22
- 18 - 37a
- 18 - 37b
- 1 - 40
- 2 - 48a
- 1 - 52
- 2 - 155
- 2 - 126
- 4 - 235a



38

Ladder with wheels  
Echelle sur roues  
Scala a ruote  
Leiter mit Raedern  
Escada de rodas



40

Catapult  
Catapulte  
Catapulta  
Katapult  
Catapulta

**CATAPULTA 1/40**

- 3 - 2
- 2 - 5
- 1 - 11
- 1 - 22
- 1 - 17
- 4 - 35
- 11 - 37b
- 11 - 37a
- 1 - 52
- 1 - 57b
- 1 - 111c
- 2 - 126
- 1 - 142c

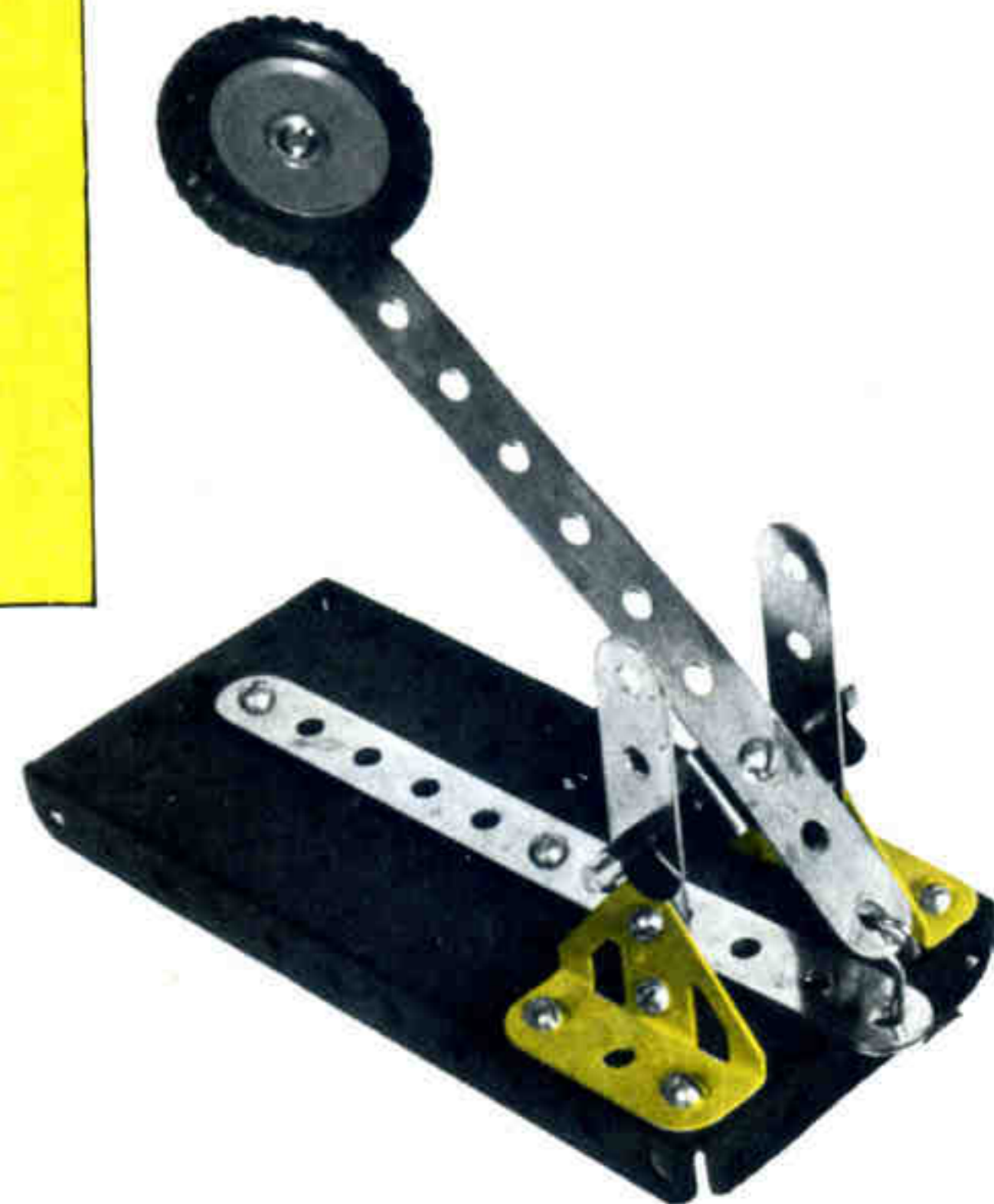

**TOBOGAN 1/41**

- 4 - 2
- 2 - 5
- 1 - 11
- 4 - 12
- 1 - 18b
- 2 - 22
- 19 - 37a
- 17 - 37b
- 2 - 38
- 2 - 90a
- 2 - 111c
- 2 - 126
- 2 - 126a
- 2 - 235a



41

Toboga  
Toboggan  
Toboga  
Rutsche  
Tobogán

**ESQUIADOR 1/39**

- 2 - 2
- 1 - 5
- 4 - 12
- 10 - 37a
- 10 - 37b
- 1 - 22
- 2 - 90a
- 1 - 111c
- 1 - 126a
- 4 - 235a

39

Skier  
Skieur  
Sciatore  
Skilaeufer  
Esquiador

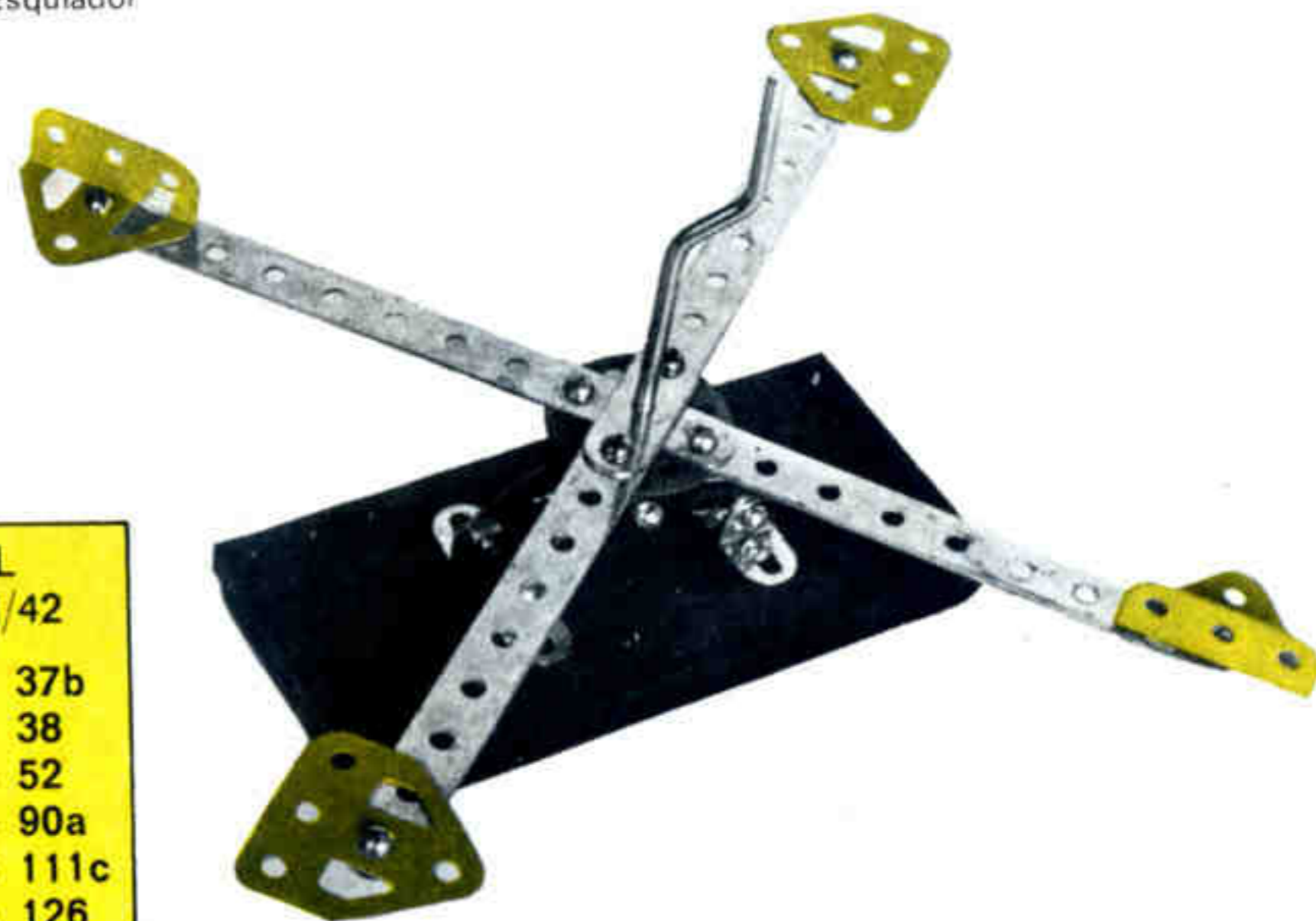

42

Round-about  
Tourniquet  
Girasole infantile  
Drehschaukel  
Girassol infantil

**GIRASOL INFANTIL 1/42**

- 4 - 2
- 1 - 11
- 4 - 12
- 1 - 19s
- 1 - 22
- 1 - 24
- 18 - 37a
- 16 - 37b
- 4 - 38
- 1 - 52
- 2 - 90a
- 2 - 111c
- 2 - 126
- 2 - 126a



**CARRO  
SERVICIO 1/43**

2 - 5  
1 - 16  
2 - 22  
8 - 37a  
8 - 37b  
1 - 48a  
1 - 52  
2 - 90a  
2 - 126a  
2 - 142c

43  
Barrow  
Chariot de service  
Carrello servizio  
Dienstleistungskarren  
Carro de servicio

45  
Motor vespa  
Moto vespa  
Moto vespa  
Vespa-Motorroller  
Moto vespa

**MOTO VESPA  
1/45**

2 - 5    21 - 37b  
4 - 10    6 - 38  
1 - 11    2 - 48a  
4 - 12    2 - 90a  
1 - 16    2 - 126  
1 - 17    2 - 126a  
1 - 18b    2 - 142c  
2 - 22    1 - 193  
4 - 35    2 - 194  
22 - 37a



46  
Greyhound  
Lévrier  
Levriere  
Windhund  
Galgo

**GALGO 1/46**

2 - 2  
2 - 10  
1 - 11  
2 - 12  
1 - 17  
2 - 35  
13 - 37a  
13 - 37b  
2 - 38  
2 - 126a  
4 - 235a

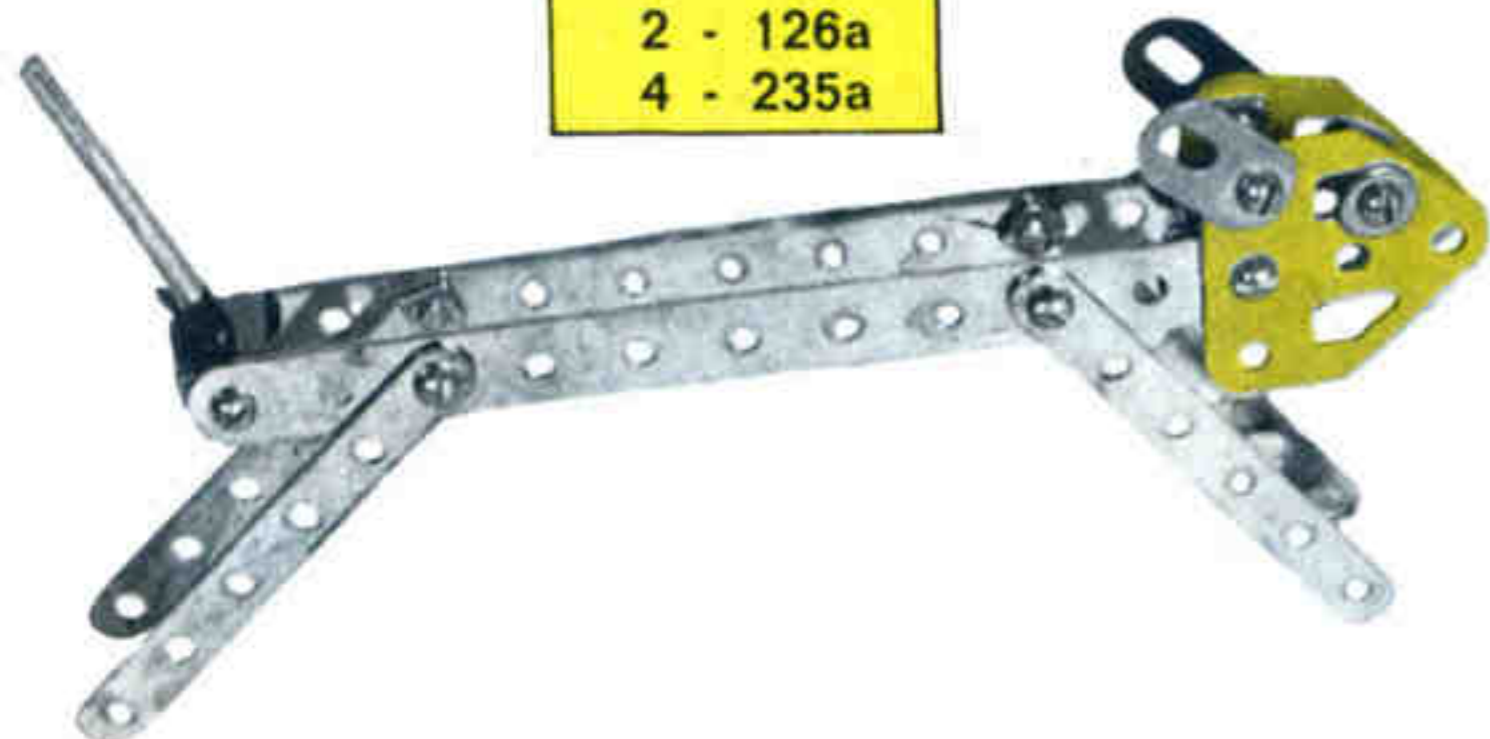

44  
Swing  
Balancoire  
Altalena  
Schaukel  
Baloço

**COLUMPIO 1/44**

4 - 2    6 - 38  
2 - 5    2 - 48a  
4 - 10    1 - 52  
1 - 11    2 - 90a  
4 - 12    1 - 111c  
1 - 16    2 - 126  
1 - 22    2 - 126a  
4 - 35    2 - 194  
24 - 37a    4 - 235a  
24 - 37b



**BALANZA 1/47**

4 - 2  
2 - 5  
1 - 11  
4 - 12  
1 - 18b  
2 - 35  
28 - 37a  
24 - 37b  
6 - 38b  
2 - 48a  
1 - 52  
2 - 126  
2 - 126a  
1 - 194

47  
Balance  
Balance  
Bilancia  
Waage  
Balança





**GIMNASTA 1/48**

|    |   |      |
|----|---|------|
| 4  | - | 2    |
| 1  | - | 5    |
| 4  | - | 10   |
| 1  | - | 17   |
| 1  | - | 18b  |
| 1  | - | 19s  |
| 2  | - | 22   |
| 1  | - | 24   |
| 4  | - | 35   |
| 23 | - | 37a  |
| 23 | - | 37b  |
| 6  | - | 38   |
| 1  | - | 48a  |
| 1  | - | 52   |
| 2  | - | 90a  |
| 1  | - | 111c |
| 2  | - | 126  |
| 2  | - | 126a |
| 4  | - | 235a |

48  
Gymnast  
Gymnaste  
Ginnasta  
Turner  
Ginasta



49  
Fair swing  
Balancoire de foire  
Altalena fiera  
Jahrmarktschaukel  
Balancé de feira

**COLUMPIO FERIA 1/49**

|    |   |      |
|----|---|------|
| 4  | - | 2    |
| 2  | - | 5    |
| 4  | - | 12   |
| 1  | - | 16   |
| 4  | - | 35   |
| 26 | - | 37a  |
| 24 | - | 37b  |
| 4  | - | 38   |
| 1  | - | 48a  |
| 1  | - | 52   |
| 2  | - | 90a  |
| 2  | - | 111c |
| 2  | - | 126  |
| 2  | - | 126a |
| 2  | - | 194  |
| 4  | - | 235a |

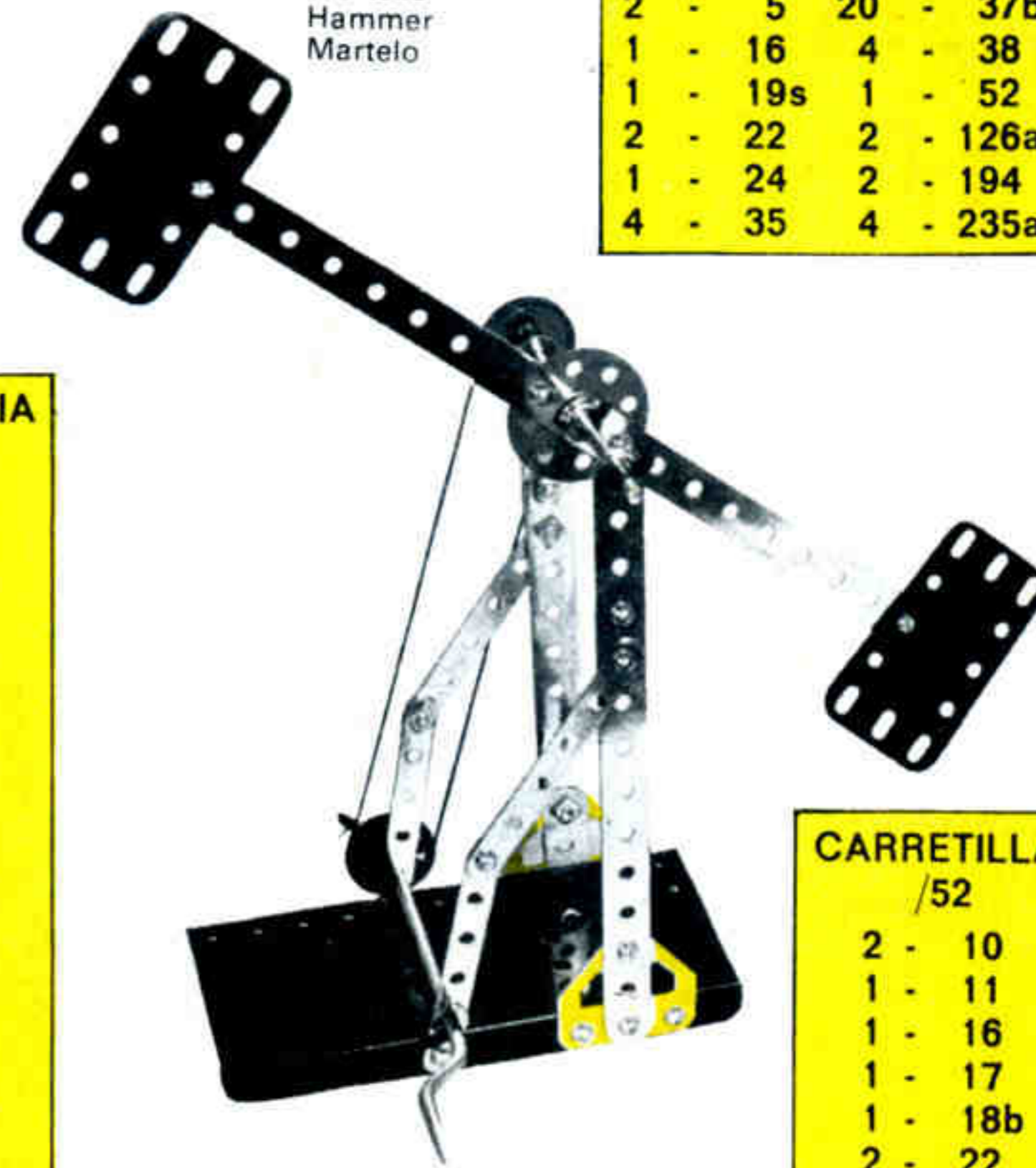

50  
Hammer  
Marteau balancier  
Martello  
Hammer  
Martelo

**« MARTILLO » 1/50**

|   |   |     |    |   |      |
|---|---|-----|----|---|------|
| 4 | - | 2   | 20 | - | 37a  |
| 2 | - | 5   | 20 | - | 37b  |
| 1 | - | 16  | 4  | - | 38   |
| 1 | - | 19s | 1  | - | 52   |
| 2 | - | 22  | 2  | - | 126a |
| 1 | - | 24  | 2  | - | 194  |
| 4 | - | 35  | 4  | - | 235a |

51  
Stretcher  
Séchoir transportable  
Stenditoio  
Waescheaufhaenger  
Estendedor

**TENDERERO 1/51**

|    |   |     |    |   |      |
|----|---|-----|----|---|------|
| 4  | - | 2   | 16 | - | 37b  |
| 2  | - | 5   | 5  | - | 38   |
| 1  | - | 10  | 1  | - | 40   |
| 2  | - | 12  | 2  | - | 48a  |
| 1  | - | 16  | 2  | - | 90a  |
| 2  | - | 35  | 2  | - | 111c |
| 22 | - | 37a | 4  | - | 235a |

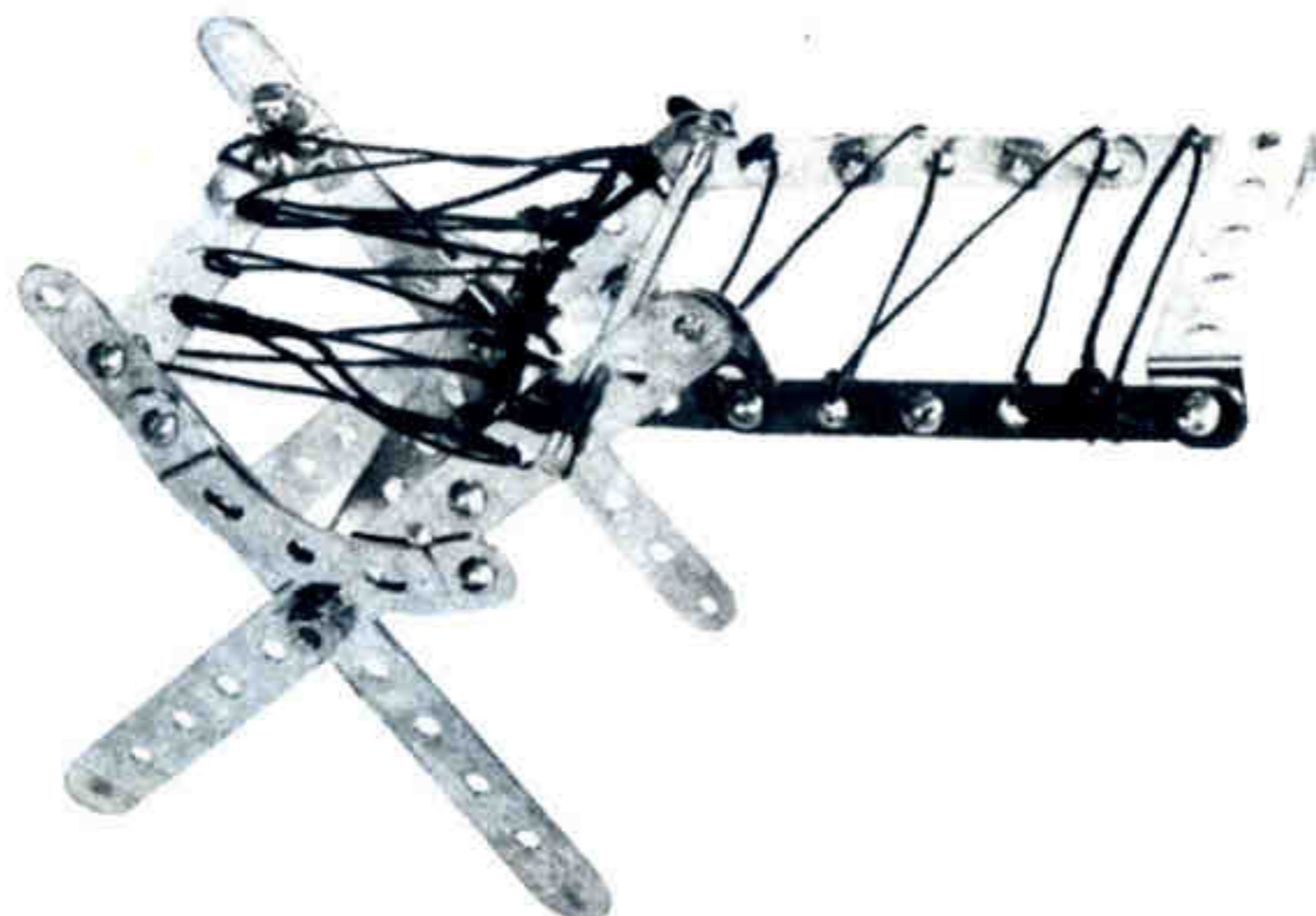

52  
Small barrow  
Chariot-remorque  
Cariola  
Handkarren  
Carretilha

**CARRETILLA /52**

|    |   |      |
|----|---|------|
| 2  | - | 10   |
| 1  | - | 11   |
| 1  | - | 16   |
| 1  | - | 17   |
| 1  | - | 18b  |
| 2  | - | 22   |
| 1  | - | 24   |
| 2  | - | 35   |
| 15 | - | 37a  |
| 12 | - | 37b  |
| 6  | - | 38   |
| 1  | - | 52   |
| 1  | - | 111c |
| 2  | - | 126  |
| 2  | - | 126a |
| 2  | - | 155  |
| 2  | - | 235a |



**PERFORADORA POR PERCUSION 1/53**

|         |          |          |
|---------|----------|----------|
| 4 - 2   | 2 - 22   | 1 - 40   |
| 2 - 5   | 1 - 24   | 2 - 90a  |
| 2 - 10  | 3 - 35   | 1 - 111c |
| 1 - 11  | 27 - 37a | 1 - 126  |
| 4 - 12  | 26 - 37b | 2 - 126a |
| 1 - 16  | 5 - 38   | 2 - 194  |
| 1 - 17  | 2 - 48a  | 3 - 235a |
| 2 - 19s | 1 - 52   |          |

53  
 Perforator for  
 percussion  
 Perforatrice à  
 percussion  
 Perforatrice da  
 percussione  
 Stossbohrmaschine  
 Perfuradora por  
 percussao

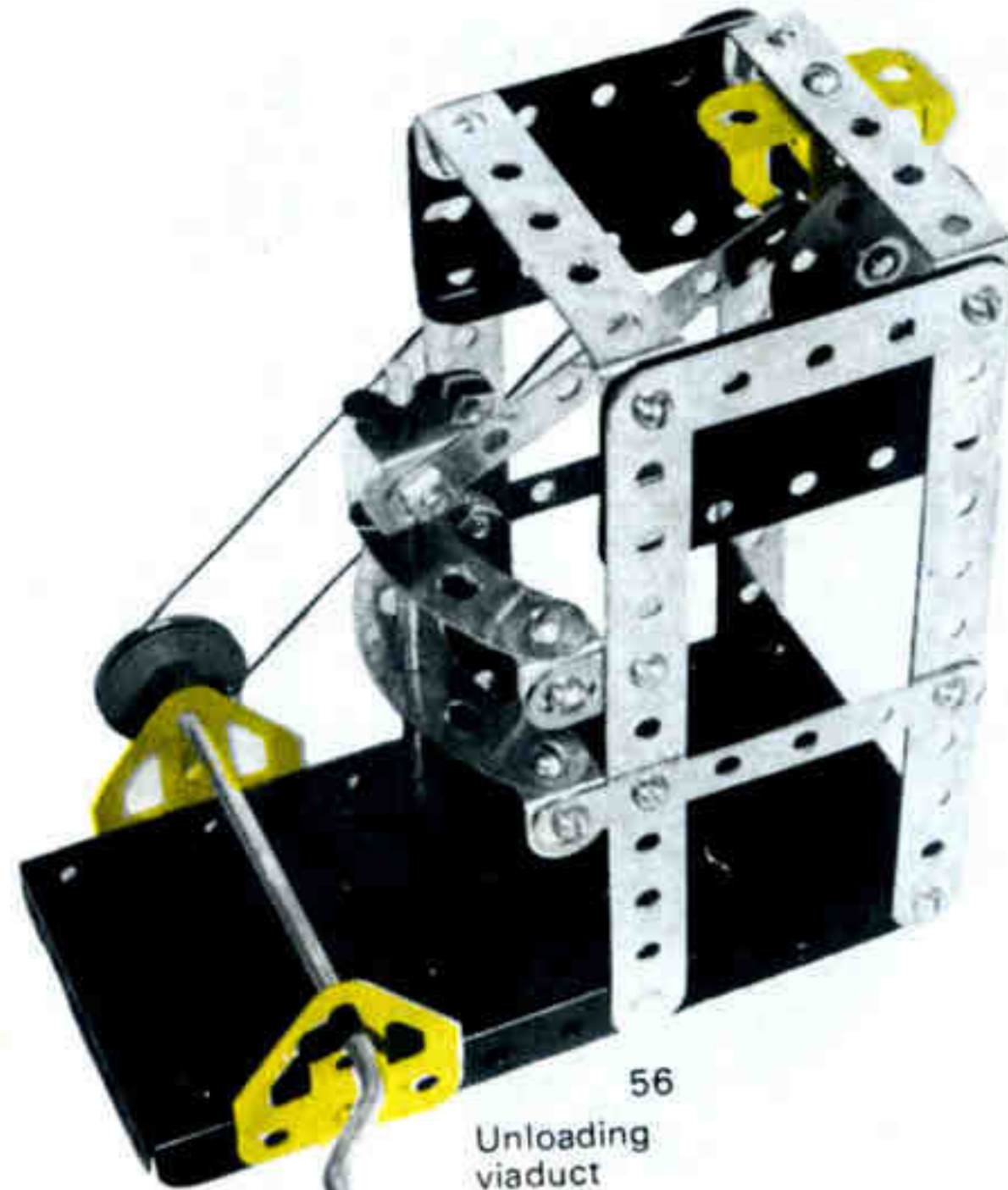

56  
 Unloading  
 viaduct  
 Téléphérique  
 de déchargement  
 Viadotto scarico  
 Abladeviadukt  
 Viaduto de descarga



**MOLINO DE VIENTO 1/54**

|          |          |
|----------|----------|
| 4 - 2    | 20 - 37b |
| 2 - 5    | 4 - 38   |
| 2 - 12   | 2 - 48a  |
| 1 - 16   | 1 - 52   |
| 2 - 22   | 2 - 126a |
| 1 - 24   | 2 - 194  |
| 4 - 35   | 4 - 235a |
| 20 - 37a |          |

54  
 Windmill  
 Moulin à vent  
 Mulino a vento  
 Windmuehle  
 Moinho de vento

55  
 Tricycle  
 Triciclo  
 Dreirad  
 Triciclo

**TRICICLO 1/55**

|          |          |
|----------|----------|
| 1 - 11   | 6 - 38   |
| 4 - 12   | 2 - 48a  |
| 1 - 16   | 1 - 52   |
| 1 - 17   | 2 - 90a  |
| 1 - 18b  | 1 - 111c |
| 2 - 22   | 2 - 126  |
| 1 - 24   | 2 - 142c |
| 4 - 35   | 1 - 193  |
| 25 - 37a | 2 - 194  |
| 24 - 37b | 4 - 235a |



**BICICLETA DE 3 RUEDAS 1/57**

|          |          |
|----------|----------|
| 1 - 2    | 10 - 37b |
| 1 - 11   | 2 - 38   |
| 4 - 12   | 1 - 48a  |
| 1 - 17   | 2 - 90a  |
| 1 - 18b  | 1 - 111c |
| 2 - 22   | 1 - 126a |
| 1 - 24   | 2 - 142c |
| 12 - 37a | 2 - 235a |

57  
 Three wheels bicycle  
 Bicyclette a trois roues  
 Bicicletta a 3 ruote  
 Dreiradfahrrad  
 Bicicleta de 3 rodas



**VIADUCTO DESCARGA /56**

|        |          |
|--------|----------|
| 4 - 2  | 22 - 37a |
| 2 - 5  | 22 - 37b |
| 2 - 10 | 2 - 48a  |
| 1 - 11 | 1 - 52   |
| 1 - 16 | 2 - 126  |
| 2 - 22 | 2 - 126a |
| 2 - 35 | 4 - 235a |





60  
Truck  
Chariot à moteur  
Motocarro  
Motorradlieferwagen  
Motocarro

| MOTOCARRO<br>1/60 |          |
|-------------------|----------|
| 2 - 5             | 23 - 37a |
| 2 - 10            | 23 - 37b |
| 1 - 11            | 6 - 38   |
| 4 - 12            | 2 - 48a  |
| 1 - 16            | 1 - 52   |
| 1 - 17            | 2 - 90a  |
| 1 - 18b           | 2 - 126a |
| 2 - 22            | 1 - 126  |
| 1 - 24            | 2 - 155  |
| 2 - 35            | 2 - 235a |



59  
Rotating crane  
Grue sur pivot  
Gru girevole  
Drehkran  
Grua giratória

| GRUA GIRATORIA<br>1/59 |          |
|------------------------|----------|
| 4 - 2                  | 6 - 38   |
| 2 - 5                  | 2 - 48a  |
| 4 - 12                 | 1 - 52   |
| 1 - 16                 | 1 - 57d  |
| 1 - 17                 | 1 - 40   |
| 1 - 19s                | 2 - 90a  |
| 2 - 22                 | 2 - 111c |
| 1 - 24                 | 2 - 126  |
| 4 - 35                 | 2 - 126a |
| 27 - 37a               | 4 - 235a |
| 22 - 37b               |          |



61  
Man  
Homme  
Uomo  
Mensch  
Homem

| HOMBRE 1/61 |  |
|-------------|--|
| 1 - 52      |  |
| 1 - 126a    |  |
| 2 - 12      |  |
| 2 - 90a     |  |
| 2 - 235a    |  |
| 1 - 22      |  |
| 1 - 111c    |  |
| 6 - 37b     |  |
| 6 - 37a     |  |



| REMOLQUE 1/58 |          |
|---------------|----------|
| 1 - 11        | 3 - 38   |
| 1 - 17        | 1 - 52   |
| 1 - 18b       | 2 - 90a  |
| 2 - 22        | 2 - 111c |
| 1 - 24        | 1 - 126  |
| 4 - 35        | 2 - 142c |
| 11 - 37b      | 2 - 235a |
| 12 - 37a      |          |

58  
Trailer  
Remorque  
Rimorchio  
Anhaenger  
Reboque

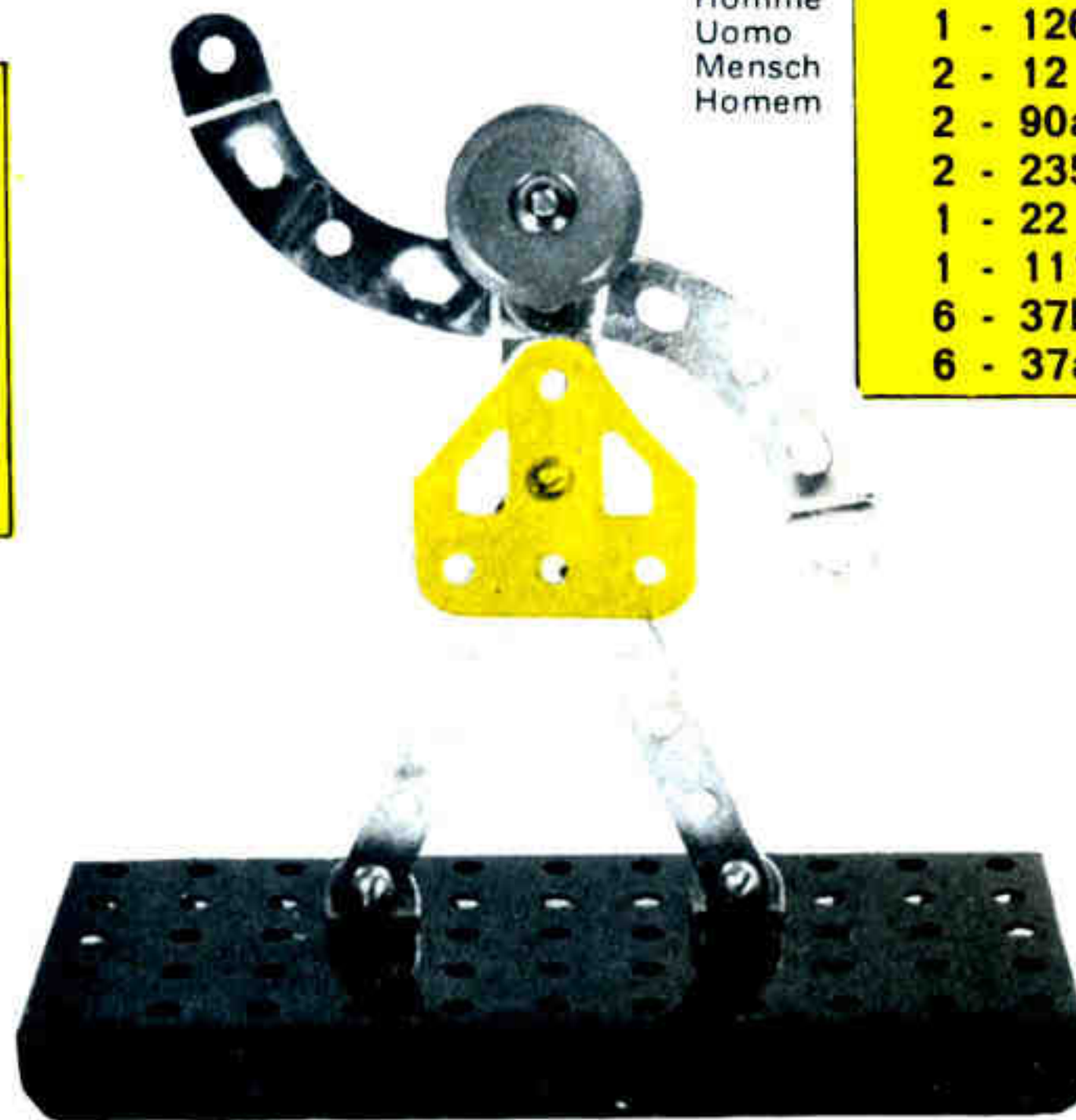

62  
Small barrow  
Diable  
Cariola  
Handkarren  
Carretilha

| CARRETILLA 1/62 |          |
|-----------------|----------|
| 2 - 2           | 2 - 48a  |
| 2 - 5           | 1 - 52   |
| 2 - 12          | 2 - 126  |
| 1 - 16          | 2 - 126a |
| 2 - 22          | 2 - 155  |
| 22 - 37a        | 1 - 194  |
| 22 - 37b        |          |

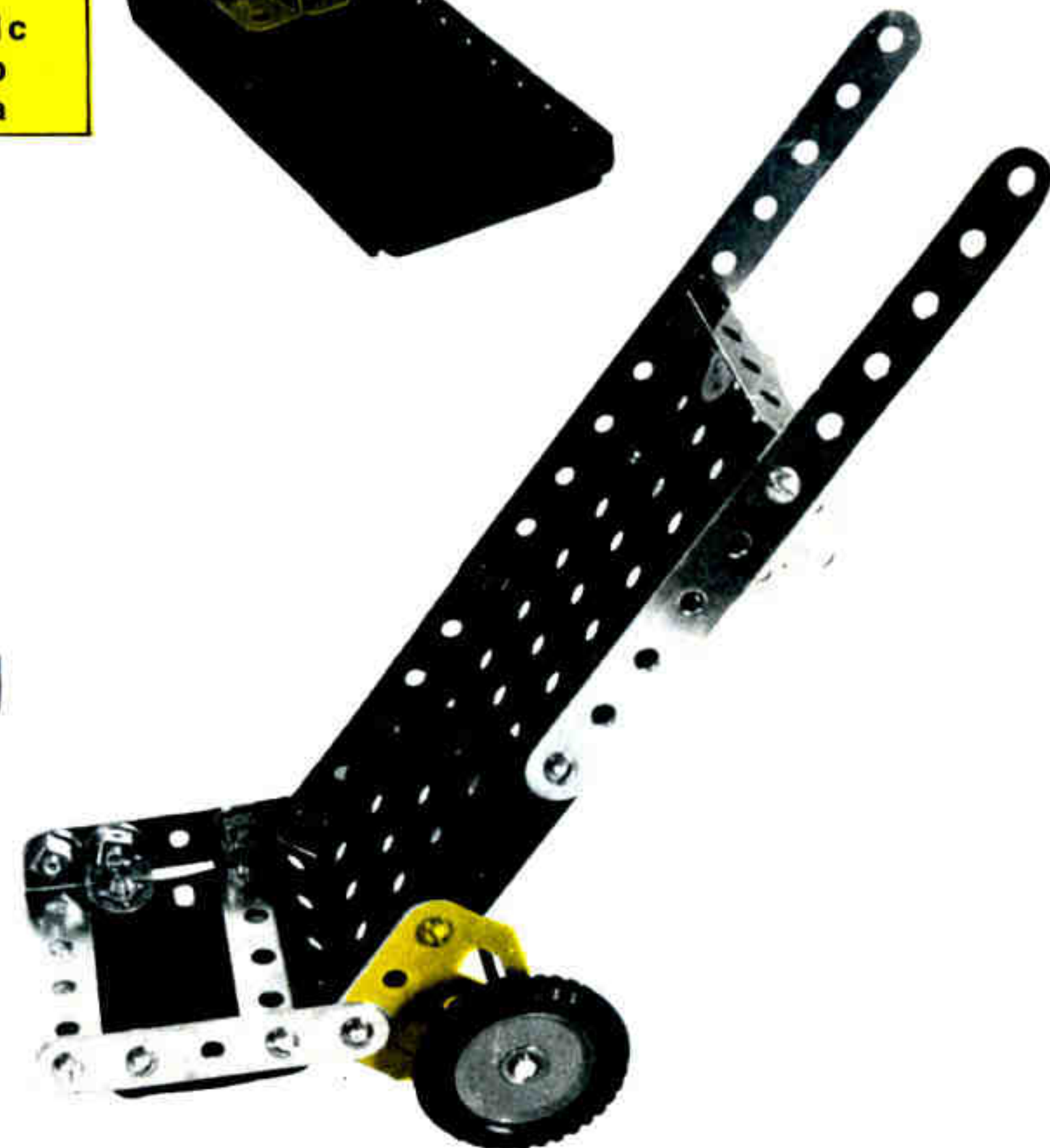

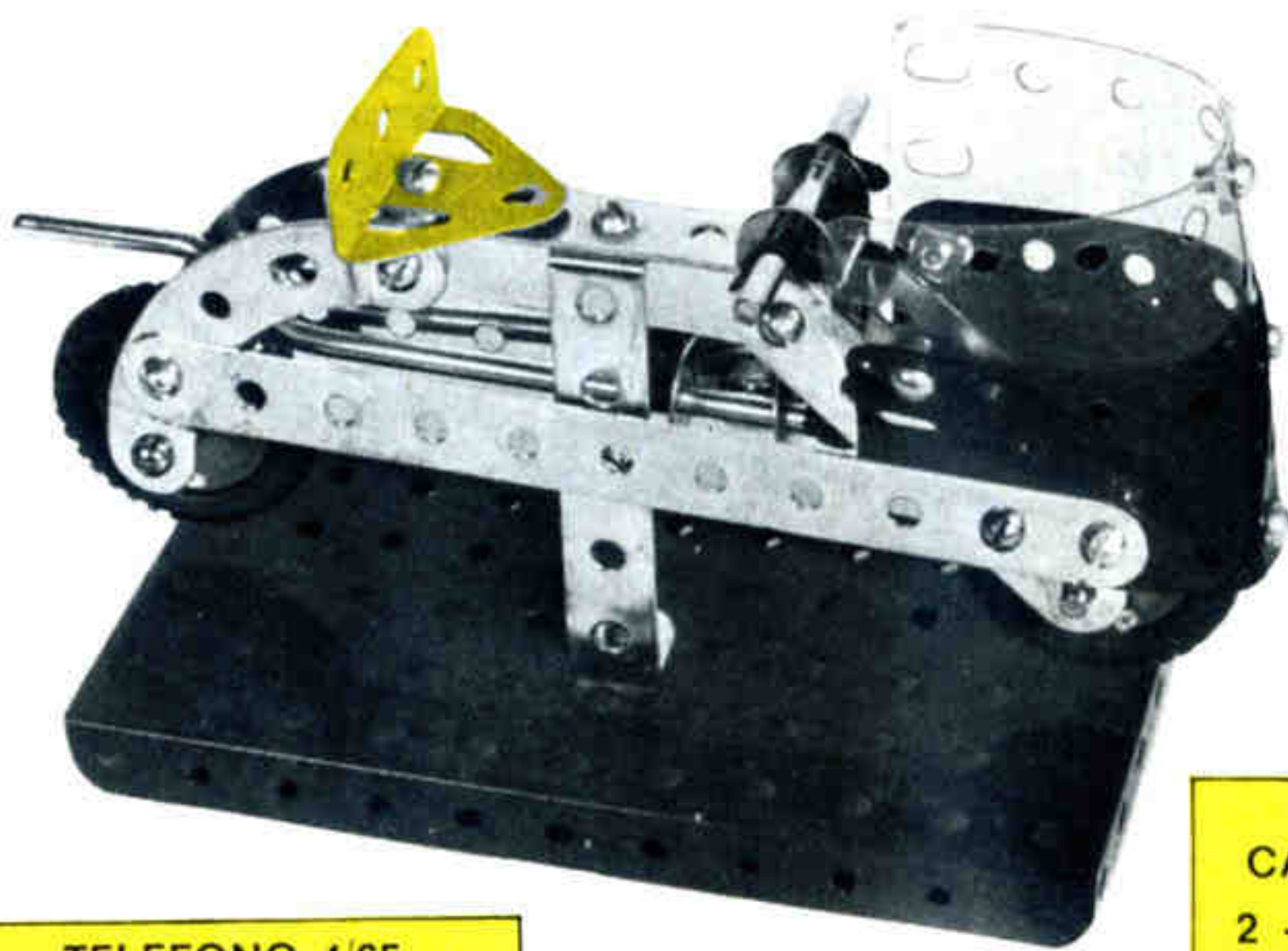

**TELEFONO 1/65**

|        |          |          |
|--------|----------|----------|
| 3 - 2  | 11 - 37a | 1 - 52   |
| 2 - 12 | 11 - 37b | 2 - 111c |
| 1 - 24 | 1 - 40   | 2 - 126  |
| 2 - 22 | 1 - 48a  | 2 - 235a |

65  
Telephone  
Téléphone  
Telefono  
Telephon  
Telefone



**MOTO DE CARRERAS 1/63**

|          |          |
|----------|----------|
| 2 - 2    | 19 - 37b |
| 2 - 5    | 6 - 38   |
| 2 - 10   | 2 - 48a  |
| 1 - 11   | 1 - 52   |
| 4 - 12   | 2 - 90a  |
| 1 - 17   | 2 - 111c |
| 1 - 18b  | 1 - 126  |
| 1 - 19s  | 2 - 155  |
| 2 - 22   | 2 - 193  |
| 2 - 35   | 2 - 194  |
| 21 - 37a |          |

63  
Racing motorbycicle  
Moto de compétition  
Moto de corsa  
Rennmotorrad  
Moto de corridas

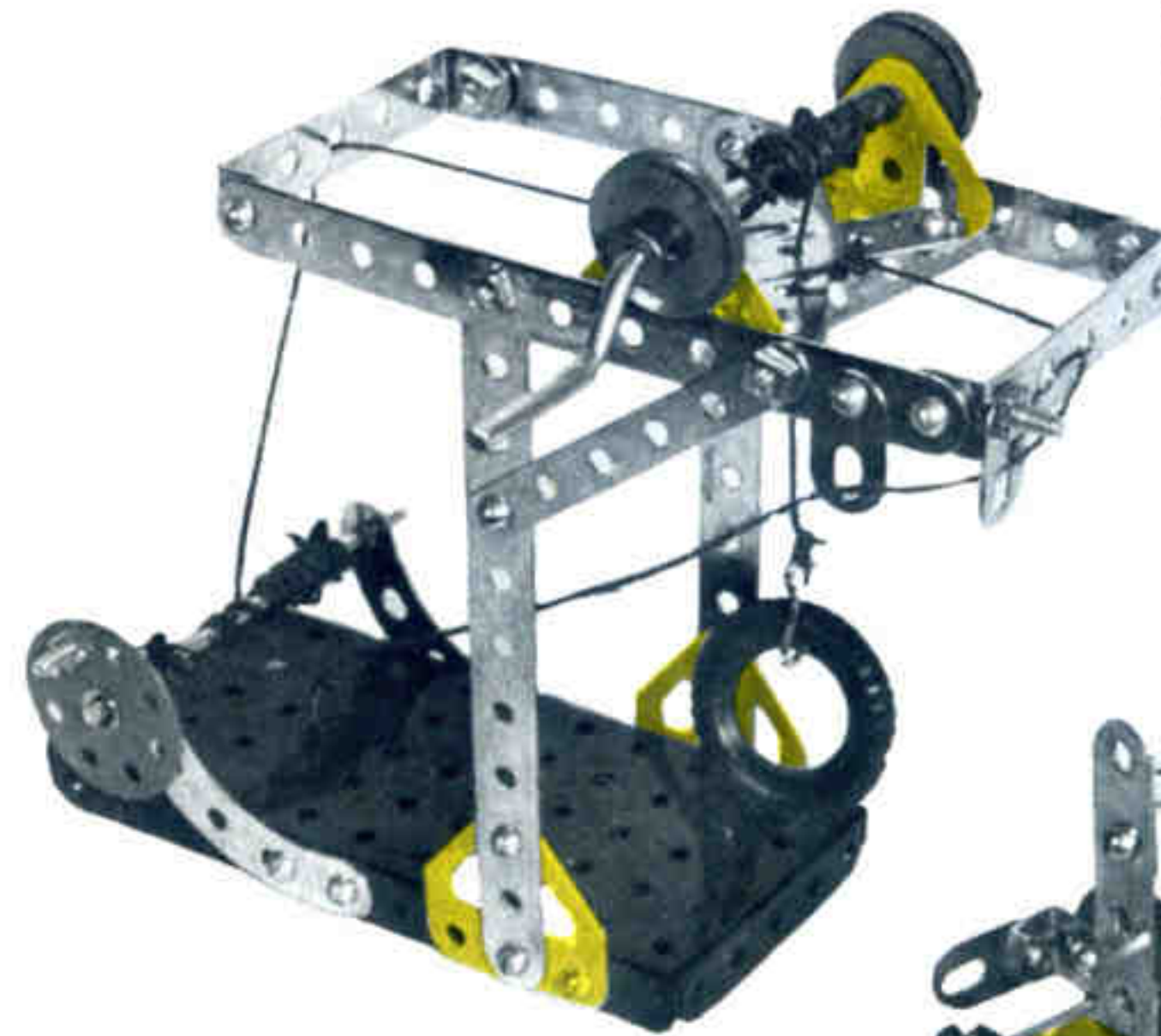

64  
Crane  
Grue  
Gru  
Kran  
Grua

**GRUA 1/64**

|          |          |
|----------|----------|
| 4 - 2    | 1 - 40   |
| 2 - 5    | 2 - 48a  |
| 2 - 10   | 1 - 52   |
| 1 - 16   | 1 - 57d  |
| 1 - 19s  | 2 - 90a  |
| 2 - 22   | 2 - 111c |
| 1 - 24   | 2 - 126  |
| 4 - 35   | 2 - 126a |
| 27 - 37a | 1 - 155  |
| 25 - 37b | 2 - 235a |
| 6 - 38   |          |

**CAÑON 1/66**

|          |          |
|----------|----------|
| 4 - 2    | 16 - 37b |
| 2 - 5    | 1 - 38   |
| 1 - 11   | 1 - 48a  |
| 4 - 12   | 1 - 126  |
| 1 - 16   | 2 - 142c |
| 2 - 22   | 1 - 194  |
| 16 - 37a |          |

66  
Cannon  
Canon  
Cannone  
Kanone  
Canhao

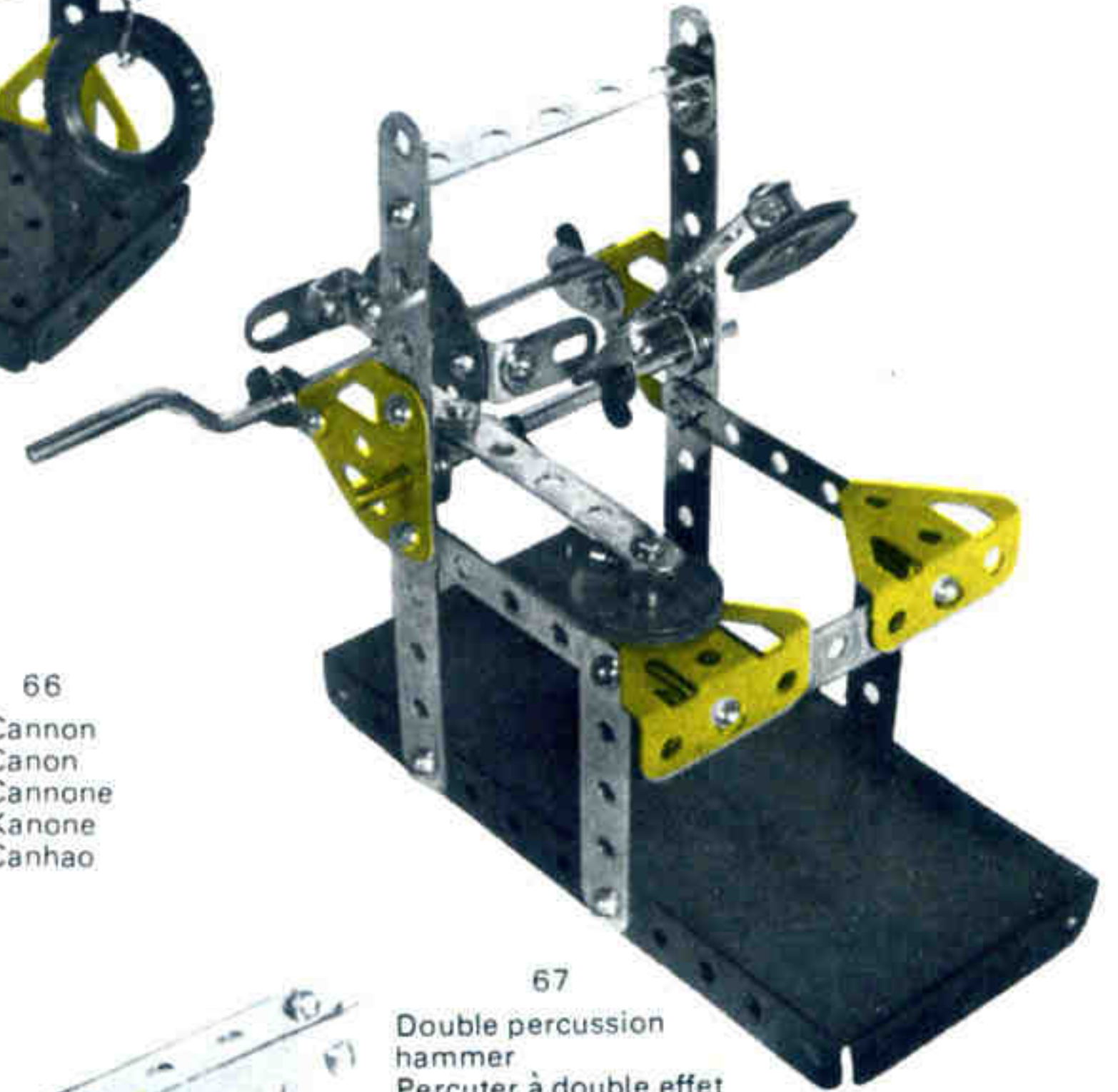

67  
Double percussion  
hammer  
Percuter à double effet  
Doppio percussore  
Doppelschlagbolzen  
Doble percussor

**DOBLE PERCUTOR 1/67**

|         |          |          |
|---------|----------|----------|
| 2 - 2   | 2 - 22   | 1 - 52   |
| 2 - 5   | 1 - 24   | 2 - 111c |
| 4 - 10  | 4 - 35   | 2 - 126  |
| 1 - 11  | 24 - 37a | 2 - 126a |
| 4 - 12  | 24 - 37b | 4 - 235a |
| 1 - 16  | 6 - 38   |          |
| 1 - 19s | 2 - 48a  |          |

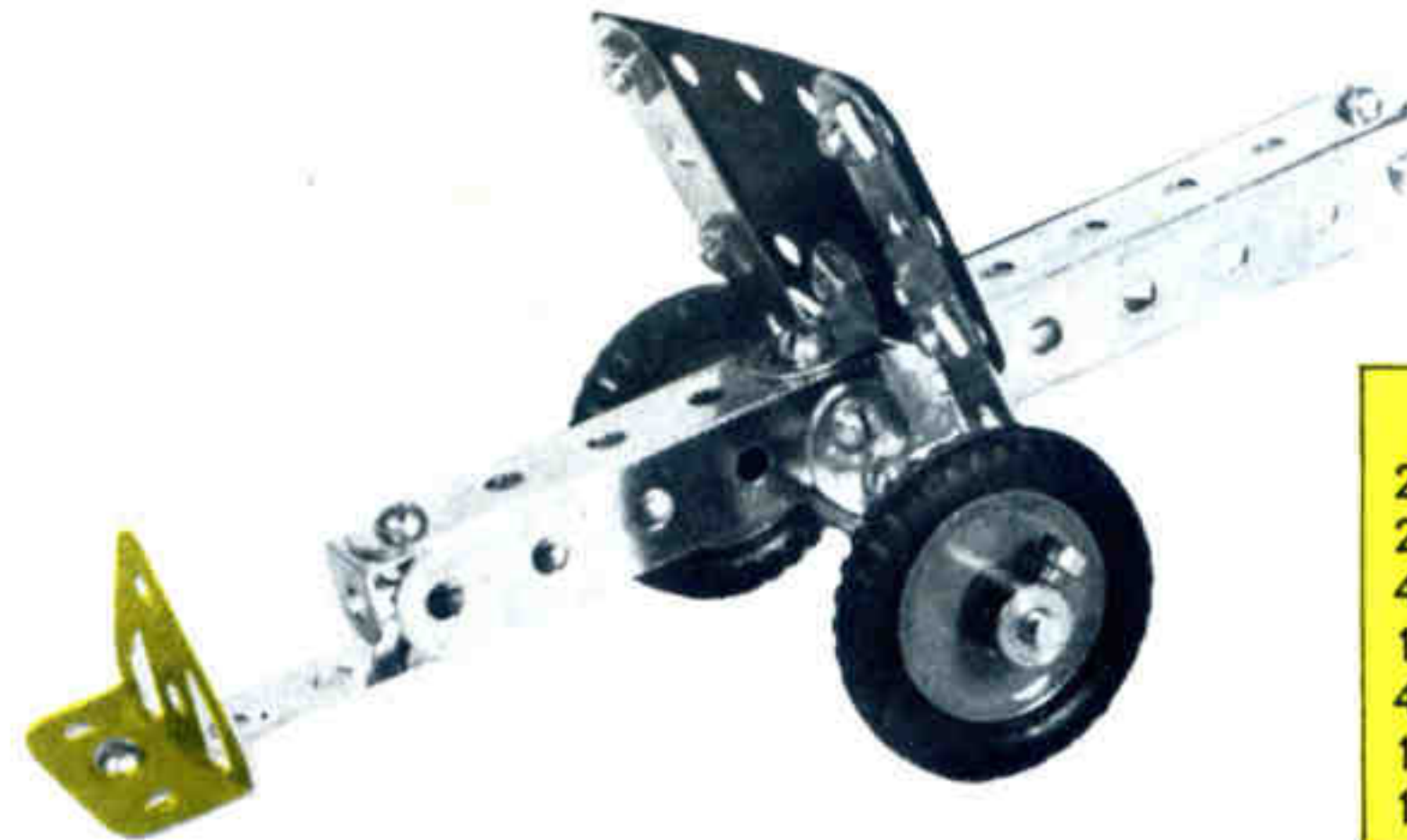

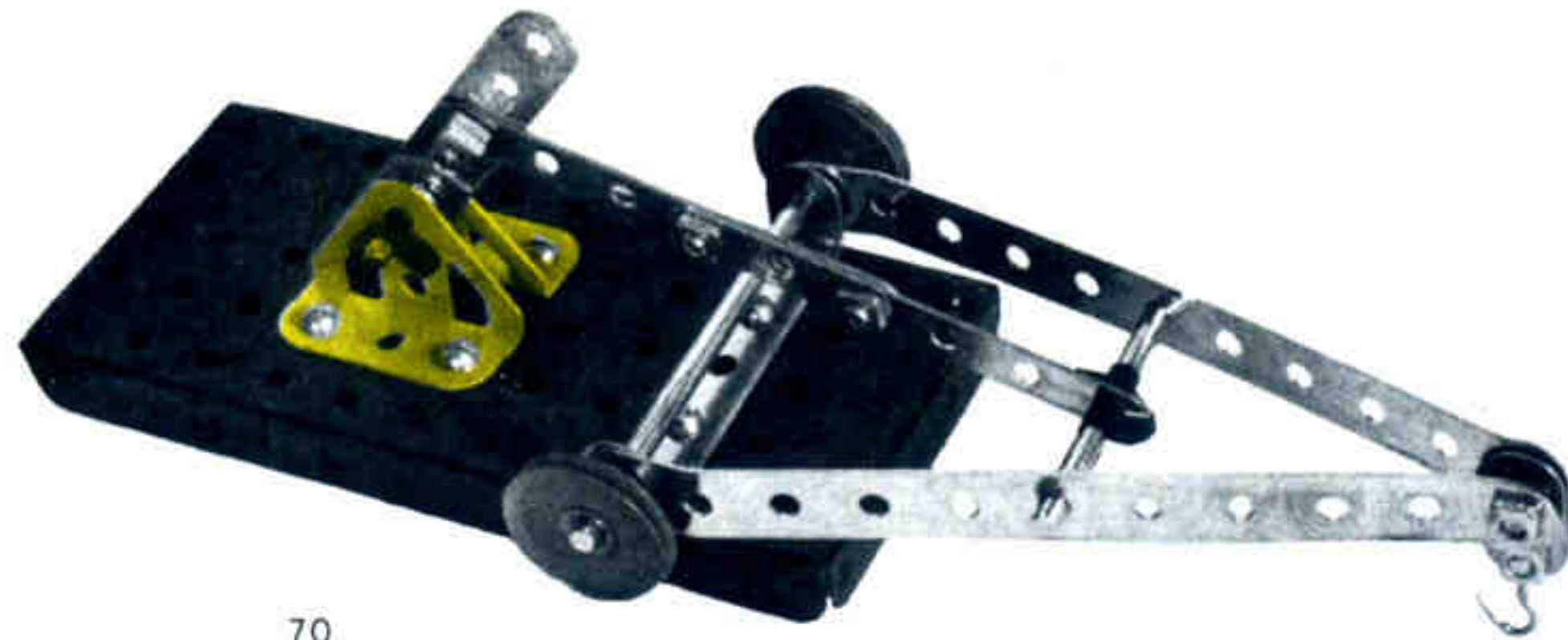

70  
Stone-cutter  
Tailleur de pierres  
Tagliapietre  
Steinklopfer  
Pedreiro

| PICAPEDRERO<br>1/70 |          |
|---------------------|----------|
| 3 - 2               | 21 - 37b |
| 2 - 5               | 6 - 38   |
| 4 - 10              | 2 - 48a  |
| 1 - 11              | 1 - 52   |
| 1 - 18b             | 2 - 90a  |
| 1 - 19s             | 2 - 111c |
| 2 - 22              | 2 - 126  |
| 1 - 24              | 2 - 126a |
| 2 - 35              | 4 - 235a |
| 26 - 37a            |          |

| ELEVADOR<br>DE CARGA 1/68 |          |
|---------------------------|----------|
| 2 - 2                     | 14 - 37a |
| 1 - 5                     | 3 - 38   |
| 2 - 10                    | 1 - 48a  |
| 1 - 16                    | 1 - 52   |
| 1 - 17                    | 1 - 57d  |
| 1 - 18b                   | 1 - 111c |
| 2 - 22                    | 2 - 126  |
| 4 - 35                    | 2 - 235a |
| 10 - 37b                  |          |

68  
Load lifter  
Élévateur  
Elevatore di carico  
Lastaufzug  
Elevador de carga



71  
Door with lock  
Porte avec targette  
Porta con nottolino  
Tuer mit Riegel  
Porta com fecho

| PUERTA CON<br>PESTILLO 1/71 |  |
|-----------------------------|--|
| 2 - 5                       |  |
| 2 - 10                      |  |
| 2 - 12                      |  |
| 16 - 37b                    |  |
| 20 - 37a                    |  |
| 2 - 48a                     |  |
| 1 - 52                      |  |
| 2 - 111c                    |  |
| 2 - 194                     |  |
| 2 - 235a                    |  |

69

Electric trolley  
Chariot électrique  
Cariola elettrica  
Elektrokarren  
Carretilha electrica

| CARRETILLA<br>ELECTRICA 1/69 |          |
|------------------------------|----------|
| 2 - 2                        | 22 - 37b |
| 2 - 5                        | 1 - 52   |
| 4 - 10                       | 1 - 57d  |
| 1 - 11                       | 1 - 90a  |
| 4 - 12                       | 1 - 111c |
| 1 - 16                       | 1 - 126  |
| 1 - 18b                      | 2 - 126a |
| 2 - 22                       | 2 - 155  |
| 1 - 24                       | 2 - 235a |
| 23 - 37a                     |          |



| MONOPLANO<br>1/72 |          |
|-------------------|----------|
| 4 - 2             | 2 - 35   |
| 2 - 5             | 23 - 37a |
| 3 - 10            | 22 - 37b |
| 1 - 11            | 2 - 38   |
| 4 - 12            | 1 - 111c |
| 1 - 17            | 2 - 126  |
| 2 - 22            | 1 - 126a |
| 1 - 24            | 2 - 235a |

72  
Monoplane  
Monoplan  
Monoplano  
Eindecker  
Monoplano

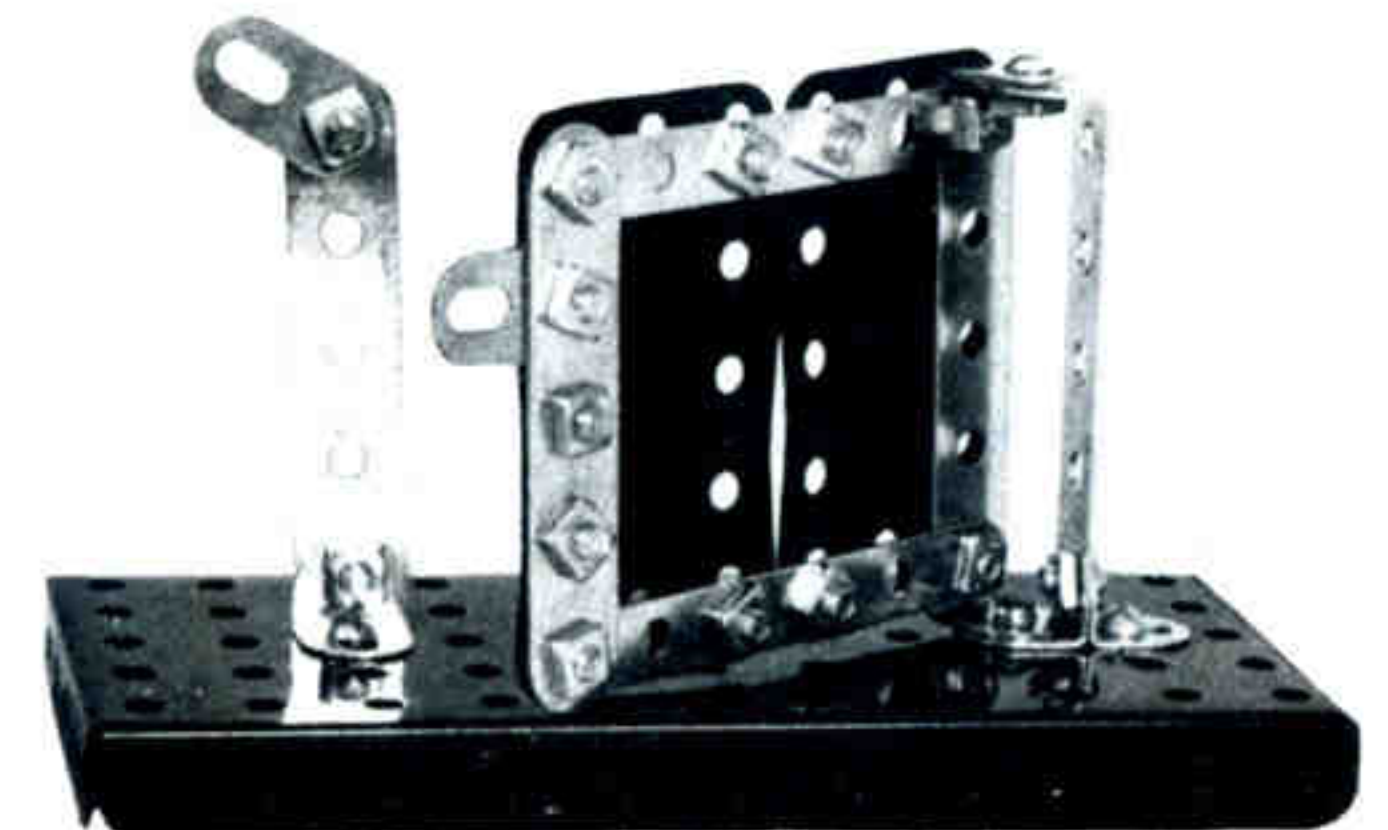





**MOTOCICLETA**

1/73

- 2 - 5
- 4 - 10
- 1 - 11
- 4 - 12
- 2 - 22
- 1 - 17
- 1 - 18b
- 2 - 35
- 25 - 37a
- 23 - 37b
- 6 - 38
- 2 - 48a
- 1 - 52
- 2 - 90a
- 2 - 111c
- 2 - 126
- 2 - 155
- 2 - 194
- 2 - 235a

73

Motorbicycle  
Motocyclette  
Motocicleta  
Kraftrad  
Motocicleta

**AVIONETA 1/76**

- 2 - 2
- 2 - 5
- 2 - 12
- 1 - 18a
- 2 - 22
- 1 - 24
- 16 - 37a
- 16 - 37b
- 1 - 111c
- 2 - 126
- 2 - 126a
- 2 - 193
- 2 - 194
- 1 - 253a



**CAROUSEL 1/74**

- 4 - 2
- 4 - 12
- 1 - 16
- 1 - 19s
- 2 - 22
- 1 - 24
- 3 - 35
- 22 - 37a
- 22 - 37b
- 3 - 38
- 2 - 48a
- 1 - 52
- 2 - 90a
- 2 - 126
- 2 - 126a

74

Carousel  
Manège  
Carroussel  
Karrussel  
Carrocel

76

Small plane  
Petit avion  
Aeroplano  
Sportflugzeug  
Avioneta

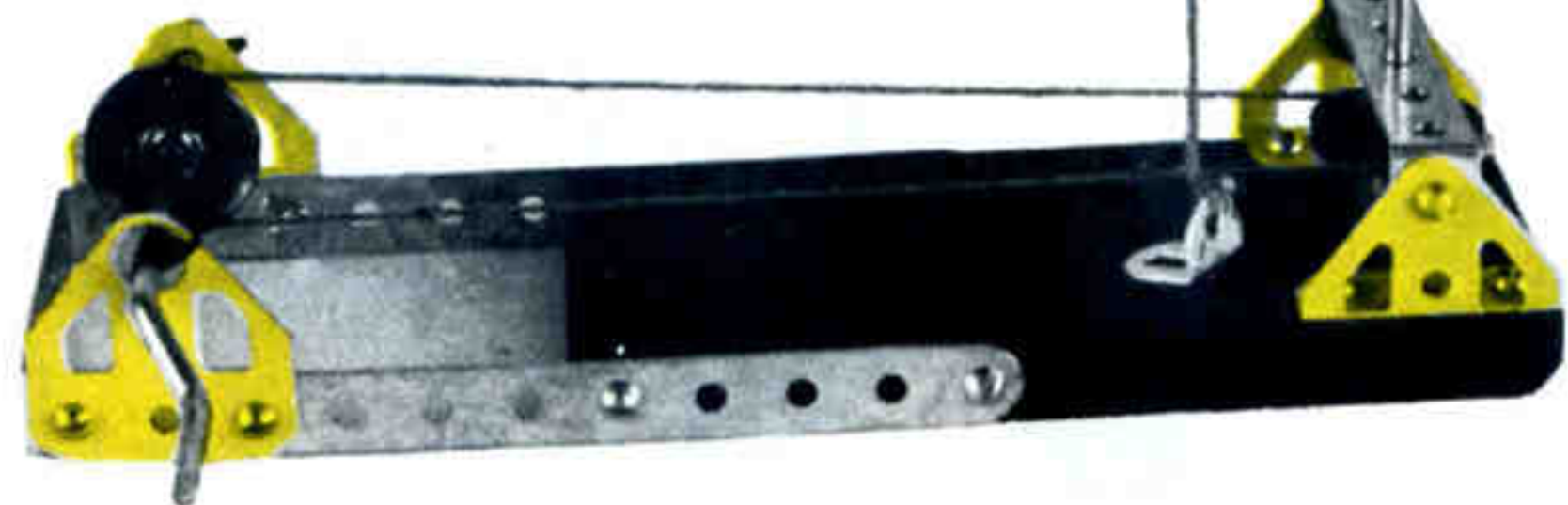

**HELICOPTERO**

1/75

- 4 - 2
- 1 - 5
- 2 - 12
- 1 - 18b
- 2 - 22
- 1 - 24
- 23 - 37a
- 23 - 37b
- 2 - 48a
- 1 - 90a
- 1 - 111c
- 2 - 126
- 1 - 126a
- 1 - 193
- 2 - 194
- 4 - 235a

75

Helicopter  
Hélicoptère  
Elicottero  
Hubscharauber  
Helicóptero



**CARABELA  
ABSTRACTA 0/77  
TODO EL EQUIPO**



77  
Abstract caravel all the  
equipment  
Tout l'equipement  
d'une caravelle  
Caravella astratta (tutto  
il gruppo)  
Karavelle abstrakt  
Caravela abstracta

**GRUA PESADA  
1/78**

|          |          |
|----------|----------|
| 4 - 2    | 5 - 38   |
| 1 - 11   | 1 - 40   |
| 2 - 12   | 2 - 48a  |
| 1 - 16   | 1 - 52   |
| 1 - 17   | 1 - 57d  |
| 1 - 19s  | 2 - 111c |
| 2 - 22   | 1 - 126  |
| 1 - 24   | 2 - 126a |
| 4 - 35   | 1 - 155  |
| 21 - 37a | 2 - 235a |
| 19 - 37b |          |

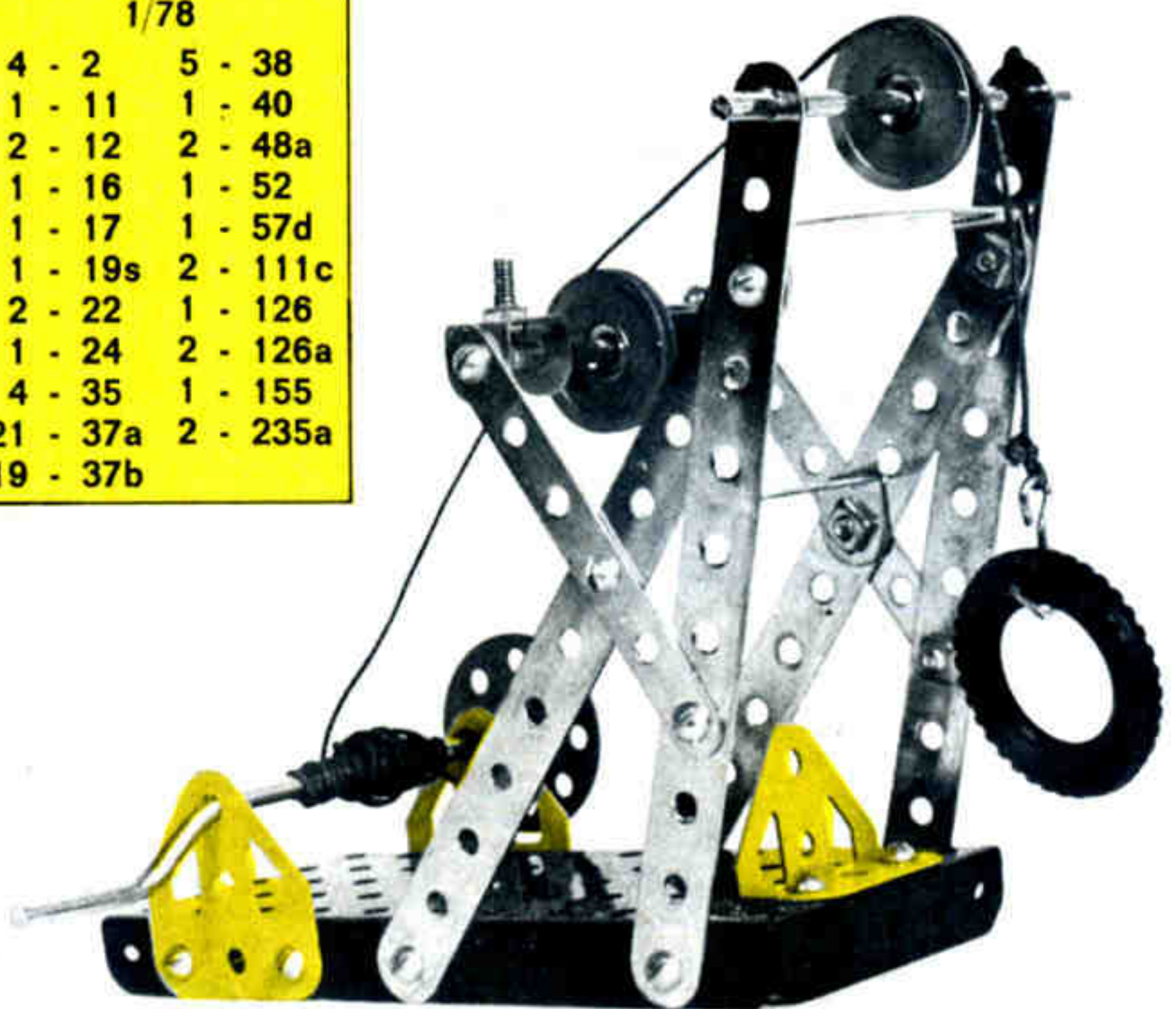

**CABALLO CON  
CARRO 1/79**

|          |          |
|----------|----------|
| 3 - 2    | 24 - 37b |
| 2 - 5    | 2 - 48a  |
| 1 - 10   | 1 - 52   |
| 1 - 11   | 2 - 90a  |
| 1 - 16   | 2 - 126  |
| 1 - 17   | 2 - 126a |
| 2 - 22   | 2 - 155  |
| 3 - 35   | 2 - 194  |
| 24 - 37a | 3 - 235a |

79  
Horse pulling cart  
Cheval avec charrette  
Cavallo con carrello  
Pferd mit Karren  
Carro com cavalo



**PERFORADORA  
/81**

|         |          |
|---------|----------|
| 4 - 2   | 4 - 35   |
| 1 - 5   | 26 - 37a |
| 2 - 10  | 24 - 37b |
| 1 - 11  | 6 - 38   |
| 4 - 12  | 1 - 52   |
| 1 - 16  | 1 - 57d  |
| 1 - 17  | 2 - 111c |
| 1 - 18b | 2 - 126  |
| 1 - 19s | 2 - 126a |
| 2 - 22  | 2 - 235a |
| 1 - 24  |          |

81  
Puncher  
Perforatrice  
Perforatrice  
Bohrmaschine  
Perfuradora



80  
Scooter with support  
Patinette avec support  
Pattino con supporto  
Roller mit Stuetze  
Patinete com suporte

**PATINETE CON SOPORTE 1 80**

|        |          |          |
|--------|----------|----------|
| 4 - 2  | 1 - 18b  | 6 - 38   |
| 2 - 10 | 2 - 22   | 1 - 46   |
| 1 - 11 | 2 - 35   | 2 - 111c |
| 4 - 12 | 20 - 37a | 2 - 155  |
| 1 - 17 | 17 - 37b | 1 - 235a |



|       |                  |
|-------|------------------|
| 82    | <b>LIRA 2/82</b> |
| Lyre  | 4 - 5            |
| Lyre  | 4 - 11           |
| Lira  | 2 - 12           |
| Leier | 2 - 22           |
| Lira  | 23 - 37b         |
|       | 23 - 37a         |
|       | 2 - 48a          |
|       | 2 - 111c         |
|       | 1 - 189          |
|       | 2 - 235a         |

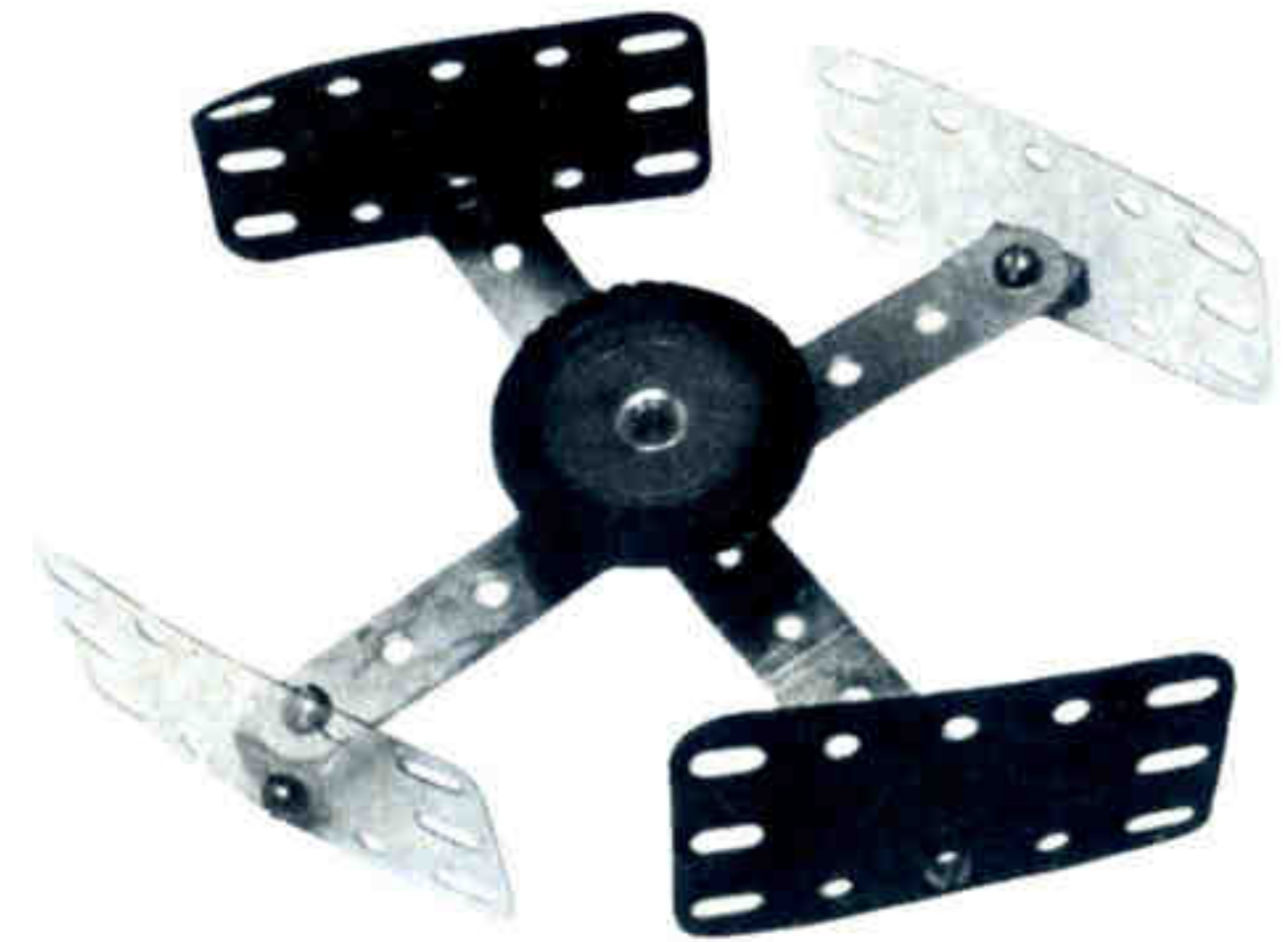

|          |                     |
|----------|---------------------|
| 83       | <b>SPUKNIK 2/83</b> |
| Sputnik  | 4 - 5               |
| Spoutnik | 4 - 12              |
| Sputnik  | 1 - 22              |
| Sputnik  | 8 - 37b             |
| Sputnik  | 9 - 37a             |
|          | 1 - 111c            |
|          | 2 - 193             |
|          | 2 - 194             |
|          | 1 - 142c            |

|                                |
|--------------------------------|
| <b>COLUMPIO DE JARDIN 2/84</b> |
| 4 - 2                          |
| 2 - 5                          |
| 4 - 10                         |
| 1 - 16                         |
| 6 - 35                         |
| 35 - 37a                       |
| 33 - 37b                       |
| 1 - 48a                        |
| 1 - 52                         |
| 2 - 90a                        |
| 2 - 111c                       |
| 2 - 126a                       |
| 2 - 189                        |
| 2 - 194                        |
| 4 - 235a                       |

84  
Garden swing  
Balancoire de jardin  
Altalena di giardino  
Gartenschaukel  
Balouco de jardim

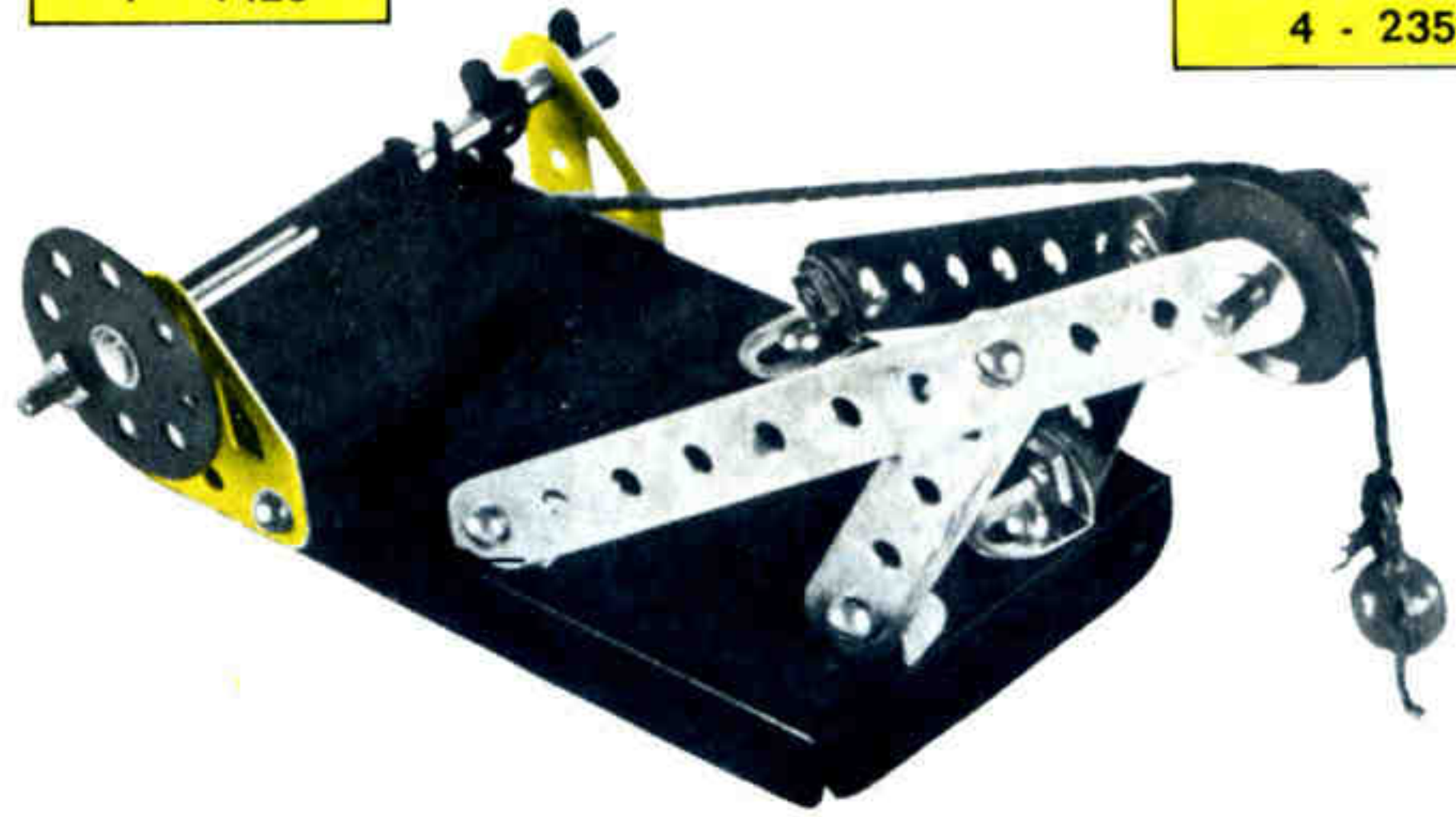

|                       |          |
|-----------------------|----------|
| <b>GRUA FIJA 2/85</b> |          |
| 2 - 2                 | 15 - 37a |
| 2 - 5                 | 16 - 37b |
| 4 - 12                | 4 - 38   |
| 1 - 16                | 1 - 52   |
| 1 - 18b               | 1 - 57c  |
| 1 - 22                | 1 - 111c |
| 1 - 24                | 2 - 126a |
| 2 - 35                |          |

85  
Fixed crane  
Grue fixe  
Gru fissa  
Befestigter Kran  
Grua fixa



86  
Swing  
Escarpolette  
Altalena  
Schaukel  
Balouço

- COLUMPIO 2/86**
- 4 - 2
  - 2 - 5
  - 2 - 12
  - 22 - 37a
  - 22 - 37b
  - 1 - 52
  - 2 - 126a
  - 1 - 194
  - 2 - 235a
  - 2 - 126

**BARCO A VELA  
SOBRE RUEDAS**

2/87

- 4 - 2
- 1 - 5
- 1 - 10
- 6 - 12
- 1 - 16
- 1 - 17
- 4 - 22
- 2 - 35
- 21 - 37a
- 25 - 37b
- 1 - 125
- 1 - 126a
- 4 - 142c
- 1 - 189
- 1 - 194
- 2 - 235a



87  
Sailing boat on wheels  
Bateau à voile sur  
roues  
Nave a vela su ruote  
Segelboot auf Raedern  
Barco à vela sobre  
rodas

**SUBMARINO 2/88**

- 2 - 10
- 4 - 12
- 1 - 186
- 1 - 24
- 14 - 37b
- 15 - 37a
- 1 - 111c
- 2 - 189
- 1 - 193
- 1 - 194

88  
Submarine  
Sous marin  
Sottomarino  
Unterseeboot  
Submarino

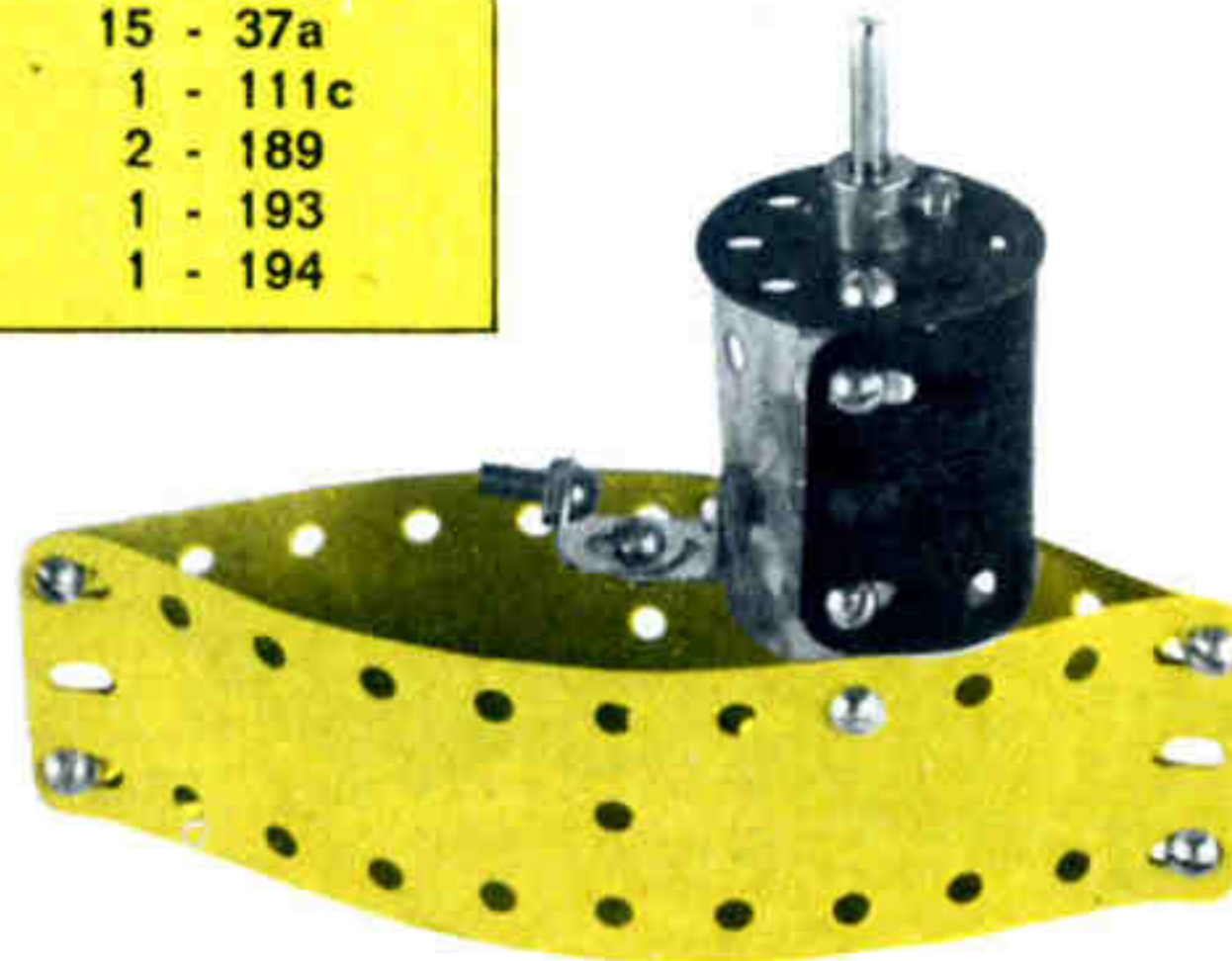

89

Battering ram  
Bélier  
Ariete  
Ramme  
Ariete

**ARIETE 2/89**

- 4 - 2
- 2 - 5
- 3 - 12
- 2 - 16
- 4 - 22
- 1 - 24
- 17 - 37a
- 17 - 37b
- 2 - 48a
- 1 - 52
- 1 - 111c
- 2 - 126
- 4 - 142c
- 2 - 189
- 2 - 194

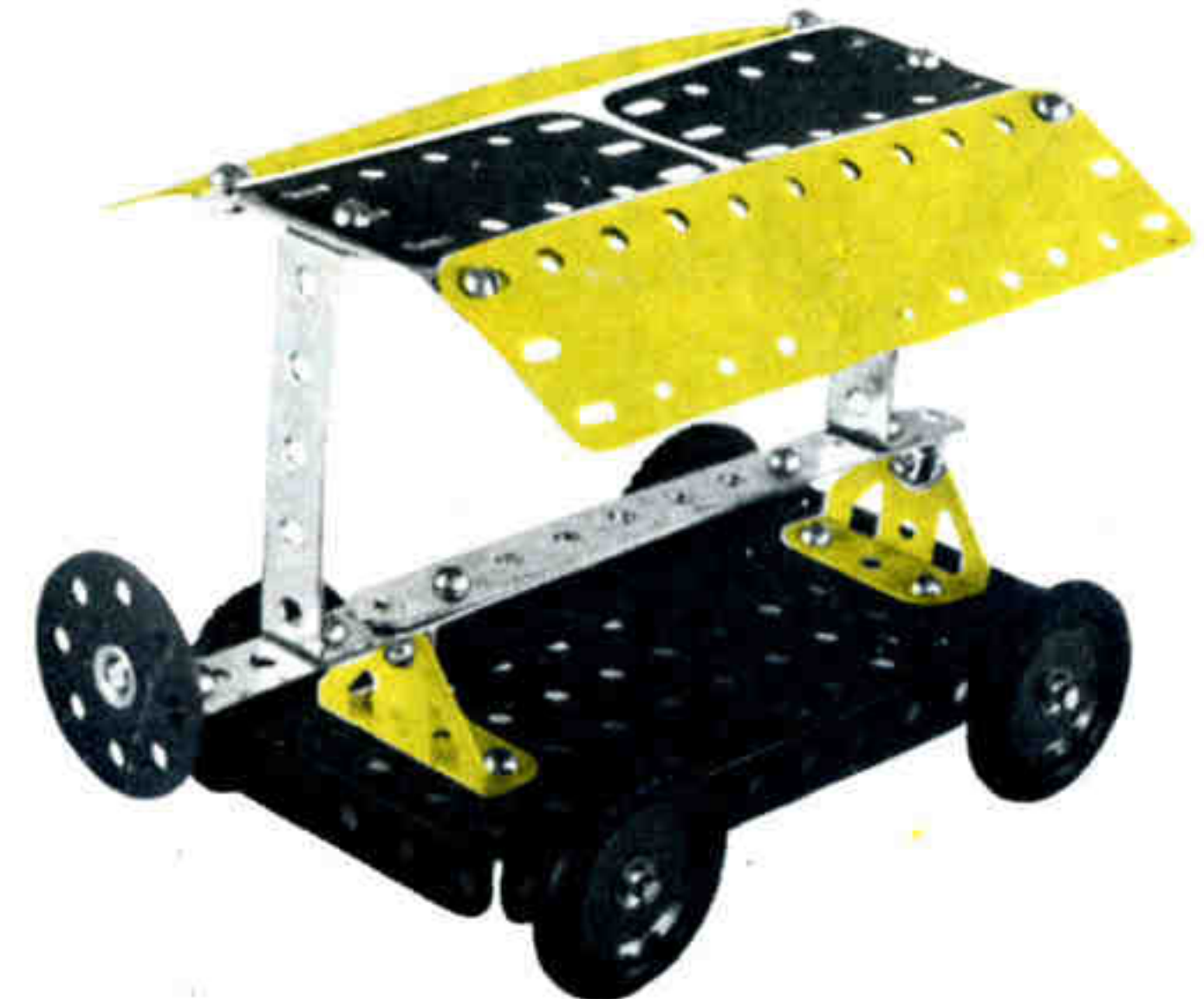

90

Radar screen  
Ecran de radar  
Schermo di radar  
Radarschirm  
Pantalha de radar

**PANTALLA DE RADAR 2/90**

- 2 - 2
- 2 - 12
- 1 - 16
- 1 - 17
- 4 - 35
- 14 - 37a
- 10 - 37b
- 4 - 38
- 1 - 90a
- 2 - 111c
- 2 - 126
- 2 - 189
- 1 - 235a

**MARINER IV 2/91**

- 2 - 2
- 2 - 10
- 2 - 12
- 1 - 22a
- 21 - 37a
- 16 - 37b
- 2 - 111c
- 2 - 126a
- 2 - 189
- 2 - 194
- 4 - 235a

91

Mariner  
Mariner IV  
Mariner IV  
Mariner IV  
Mariner IV

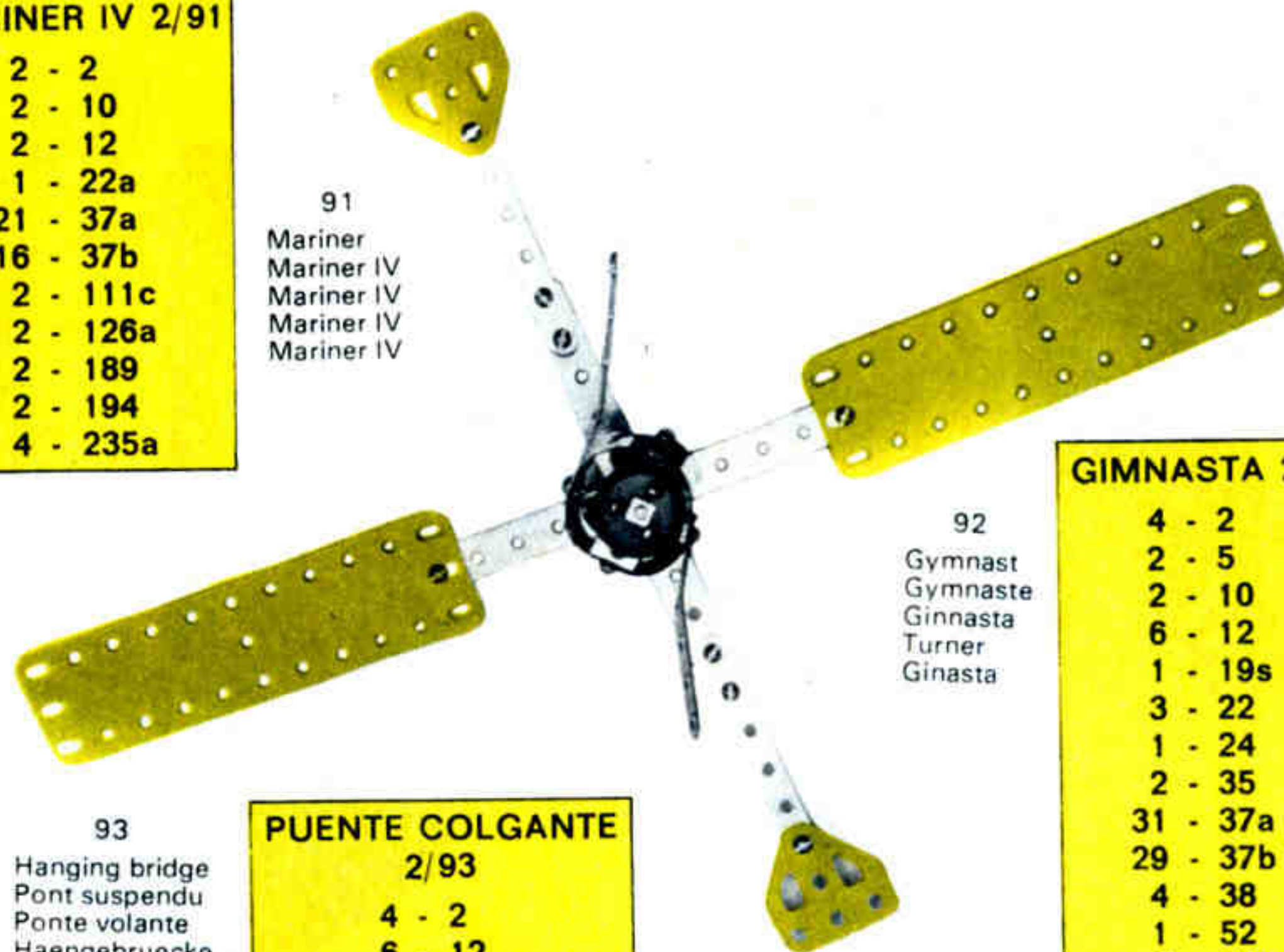

**GIMNASTA 2/92**

92  
Gymnast  
Gymnaste  
Ginnasta  
Turner  
Ginasta

- 4 - 2
- 2 - 5
- 2 - 10
- 6 - 12
- 1 - 19s
- 3 - 22
- 1 - 24
- 2 - 35
- 31 - 37a
- 29 - 37b
- 4 - 38
- 1 - 52
- 2 - 111c
- 2 - 126
- 2 - 126a
- 2 - 235a



93

Hanging bridge  
Pont suspendu  
Ponte volante  
Haengebruecke  
Ponte suspensa

**PUENTE COLGANTE 2/93**

- 4 - 2
- 6 - 12
- 2 - 17
- 4 - 35
- 10 - 37b
- 18 - 37a
- 4 - 111c
- 2 - 189
- 4 - 235a
- 1 - 40

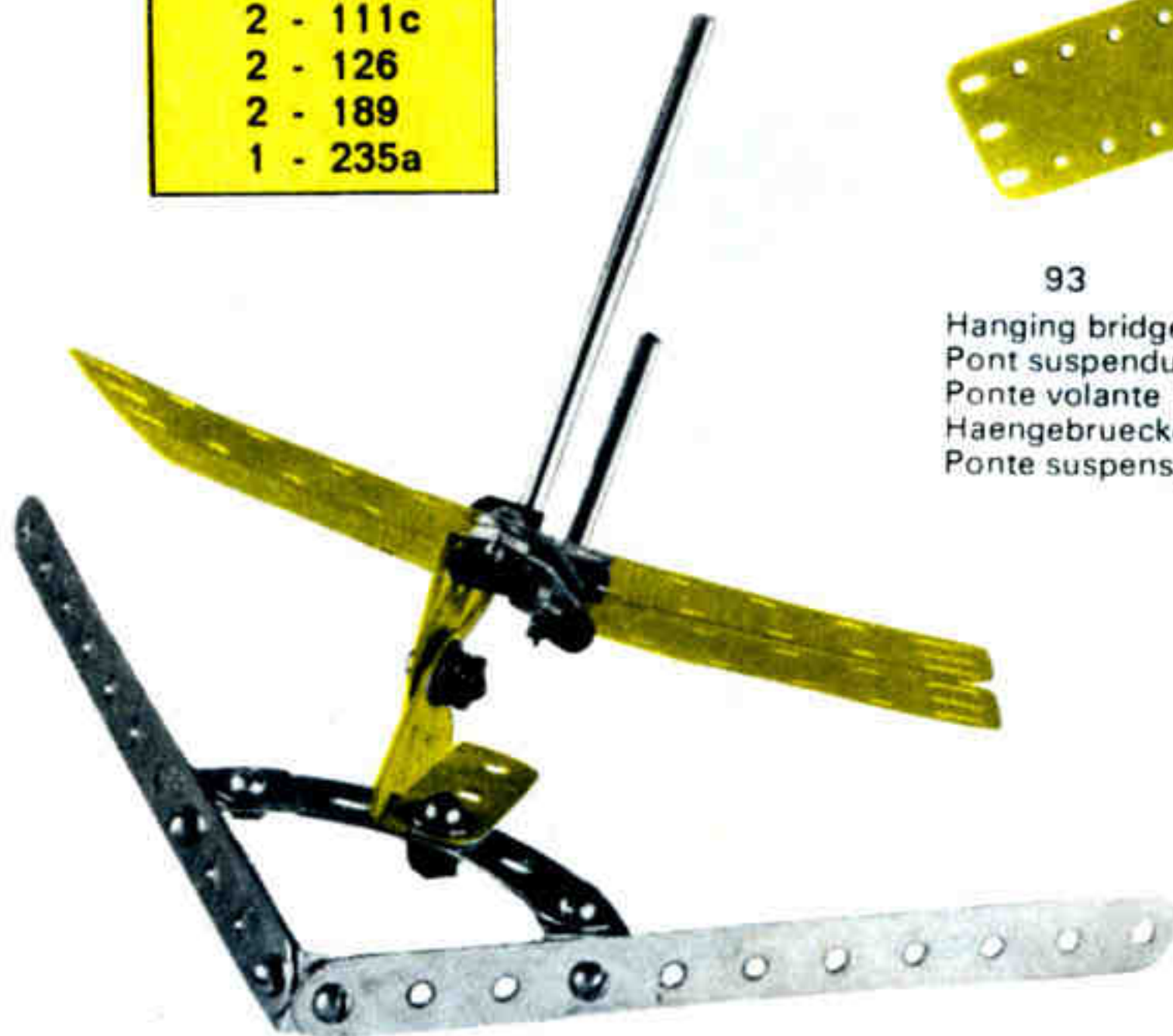



**MESA CAMPING**  
2/94

- 2 - 2
- 4 - 5
- 8 - 12
- 2 - 22a
- 31 - 37b
- 33 - 37a
- 1 - 52
- 2 - 111c
- 2 - 126a
- 2 - 155
- 2 - 189
- 2 - 194
- 4 - 235a

94  
Camping table  
Table de camping  
Tavolo campeggio  
Camping-Tisch  
Mesa campismo



96  
Heavy crane  
Grue lourde  
Gru pesante  
Lastkran  
Grua pesada

**VENTILADOR 2/95**

- 4 - 2
- 2 - 16
- 1 - 19s
- 3 - 22
- 1 - 24
- 2 - 35
- 16 - 37b
- 16 - 37a
- 1 - 52
- 2 - 126
- 2 - 126a

95  
Ventilator  
Ventilateur  
Ventilatore  
Ventilator  
Ventilador



**GRUA PESADA**  
2/96

- 4 - 2
- 1 - 11
- 2 - 17
- 1 - 18b
- 1 - 19s
- 3 - 22
- 2 - 22a
- 6 - 35
- 16 - 37b
- 22 - 37a
- 1 - 52
- 1 - 57c
- 2 - 111c
- 2 - 126
- 2 - 126a
- 3 - 142c
- 2 - 235a
- 1 - 40

**CANDIL 2/97**

- 1 - 2
- 1 - 17
- 2 - 22
- 9 - 37a
- 3 - 37b
- 2 - 111c
- 2 - 142c
- 1 - 189
- 1 - 194
- 1 - 235a

97  
Oil-lamp  
Lampe à gaz  
Lume a mano  
Schnabellampe  
Candeia





- BANDERA 2/98**
- 4 - 2
  - 1 - 12
  - 1 - 22a
  - 1 - 24
  - 16 - 37b
  - 20 - 37a
  - 1 - 52
  - 3 - 111c
  - 2 - 126
  - 2 - 189
  - 2 - 194
  - 1 - 40

98  
 Flag  
 Drapeau  
 Bandiera  
 Falgge  
 Bandeira

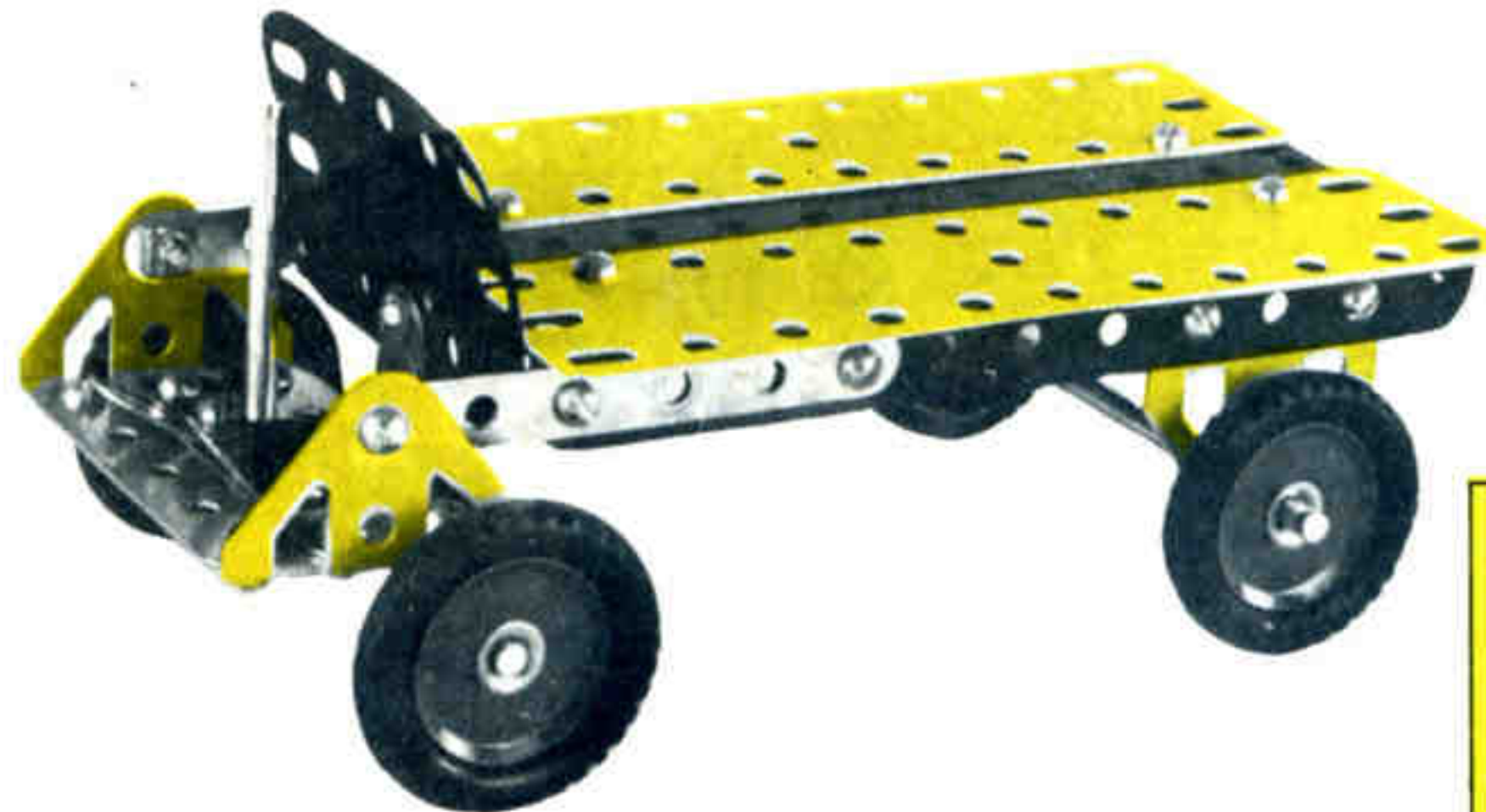

101  
 Station trolley  
 Diable de gare  
 Cariola di stazione  
 Nahnhofskarren  
 Carretilha de estação

- CARRETILLA DE ESTACION 2/101**
- 3 - 5
  - 1 - 10
  - 3 - 12
  - 2 - 16
  - 1 - 17
  - 4 - 22
  - 2 - 35
  - 25 - 37a
  - 25 - 37b
  - 4 - 38
  - 1 - 48a
  - 1 - 52
  - 2 - 126
  - 2 - 126a
  - 4 - 142c
  - 2 - 189
  - 1 - 194
  - 2 - 235a

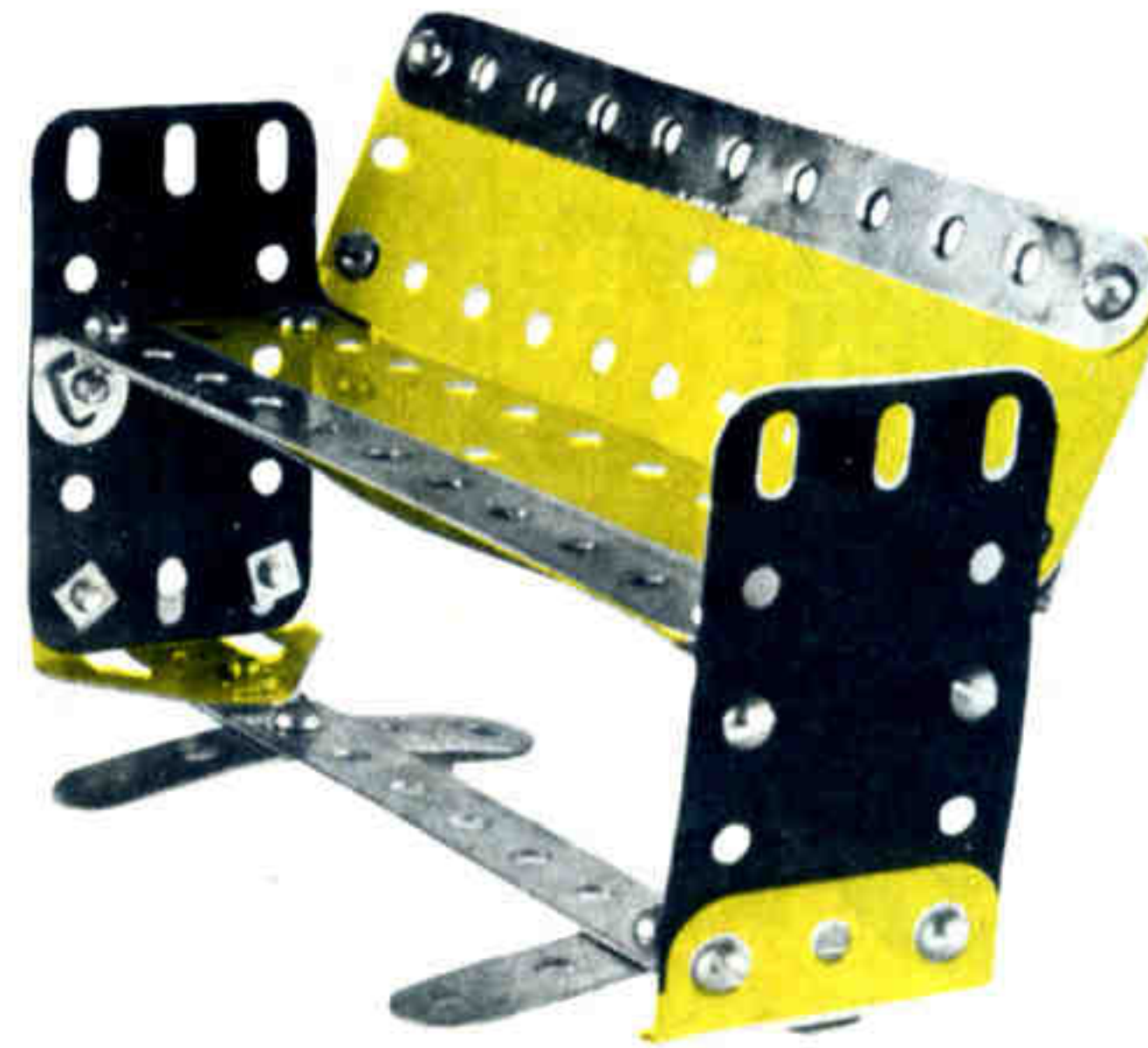

- 99  
 Settee  
 Canapé  
 Divano  
 Scaun  
 Sofá
- SOFA 2/99**
- 3 - 2
  - 2 - 5
  - 6 - 12
  - 20 - 37a
  - 20 - 37b
  - 2 - 126
  - 2 - 189
  - 2 - 194

- ROBOT 2/100**
- 2 - 5
  - 1 - 10
  - 3 - 12
  - 3 - 22
  - 13 - 37a
  - 13 - 37b
  - 2 - 90a
  - 3 - 111c
  - 2 - 126
  - 3 - 142c
  - 1 - 189
  - 2 - 194

100  
 Robot  
 Robot  
 Robot  
 Roboter  
 Robot



**CAÑÓN DE  
CAMPAÑA /102**

- |          |          |
|----------|----------|
| 2 - 5    | 2 - 38   |
| 1 - 10   | 1 - 48a  |
| 1 - 12   | 2 - 111c |
| 2 - 16   | 2 - 126  |
| 3 - 22   | 2 - 142c |
| 1 - 35   | 2 - 194  |
| 20 - 37a | 1 - 213  |
| 21 - 37b | 4 - 235a |

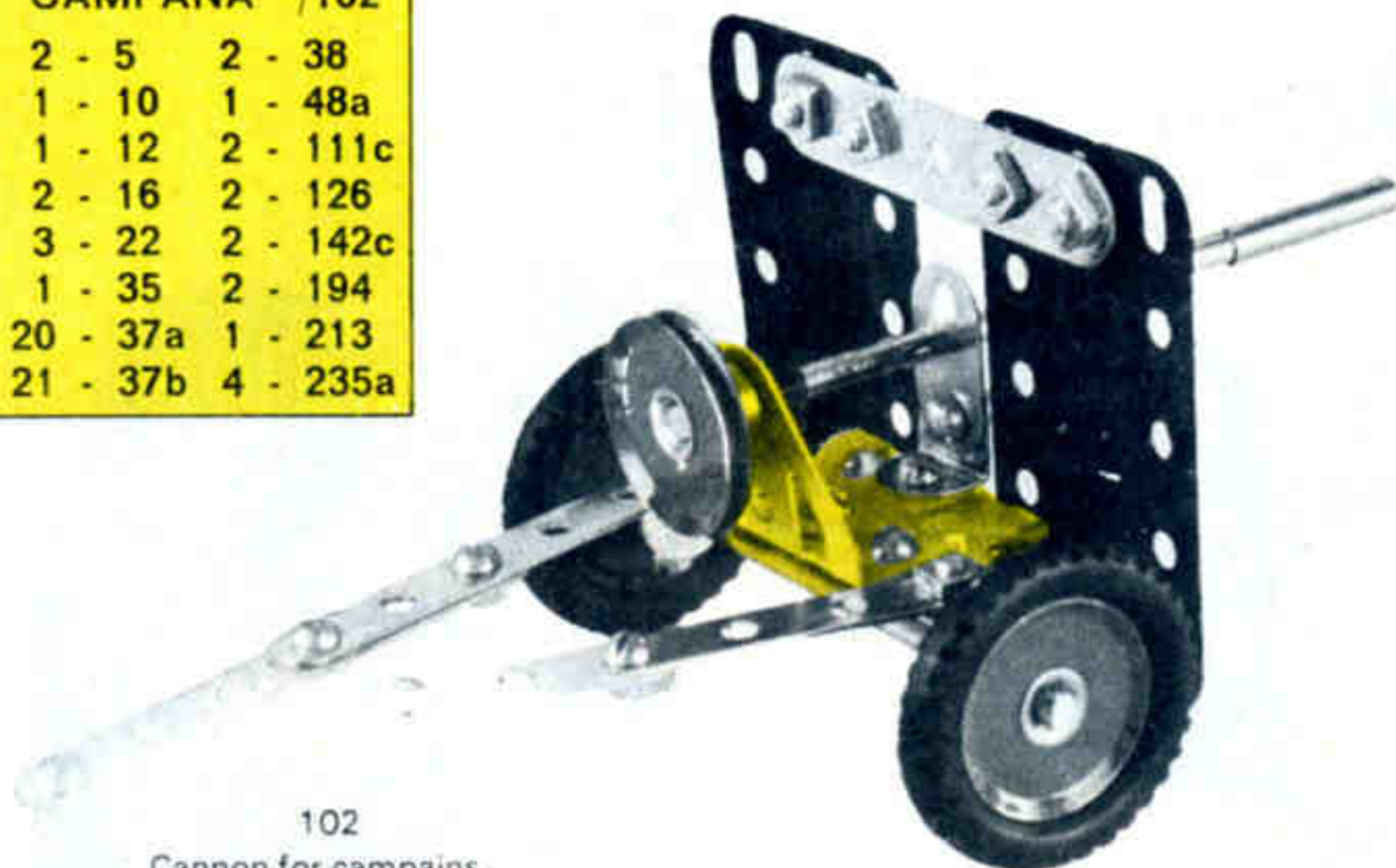

102

Cannon for campaigns  
Canon de campagne  
Cannone di campagna  
Geschuetz  
Canhão de campanha

**BASCULA 2/103**

- |          |
|----------|
| 4 - 2    |
| 3 - 5    |
| 4 - 10   |
| 8 - 12   |
| 2 - 16   |
| 2 - 17   |
| 1 - 19s  |
| 4 - 22   |
| 2 - 22a  |
| 5 - 35   |
| 40 - 37a |
| 38 - 37b |
| 8 - 38   |
| 2 - 48a  |
| 1 - 52   |
| 4 - 111c |
| 2 - 126  |
| 1 - 126a |
| 1 - 189  |
| 1 - 194  |
| 1 - 213  |
| 4 - 235a |

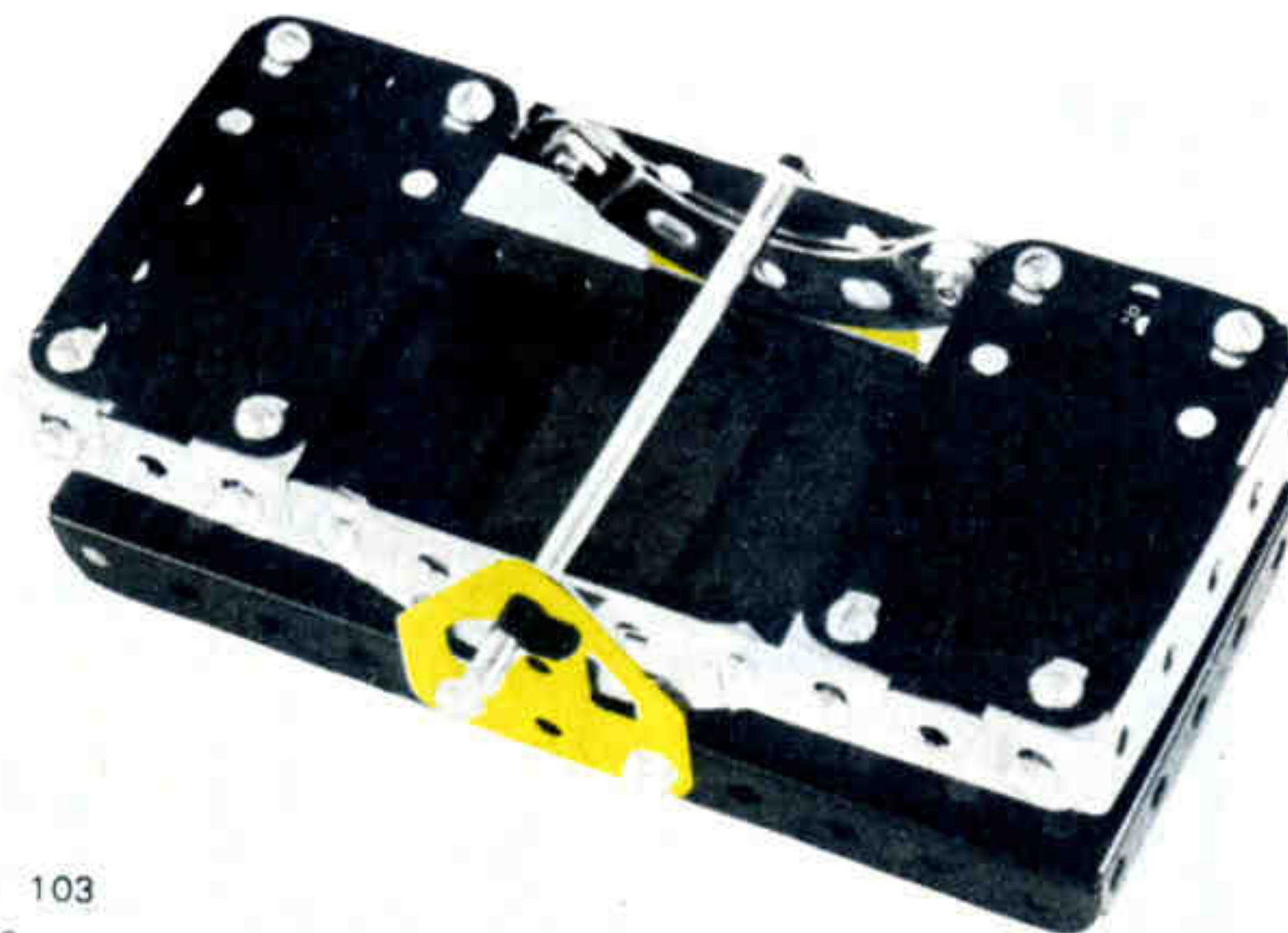

103

Scale  
Bascule  
Basculla  
Personenwaage  
Báscula

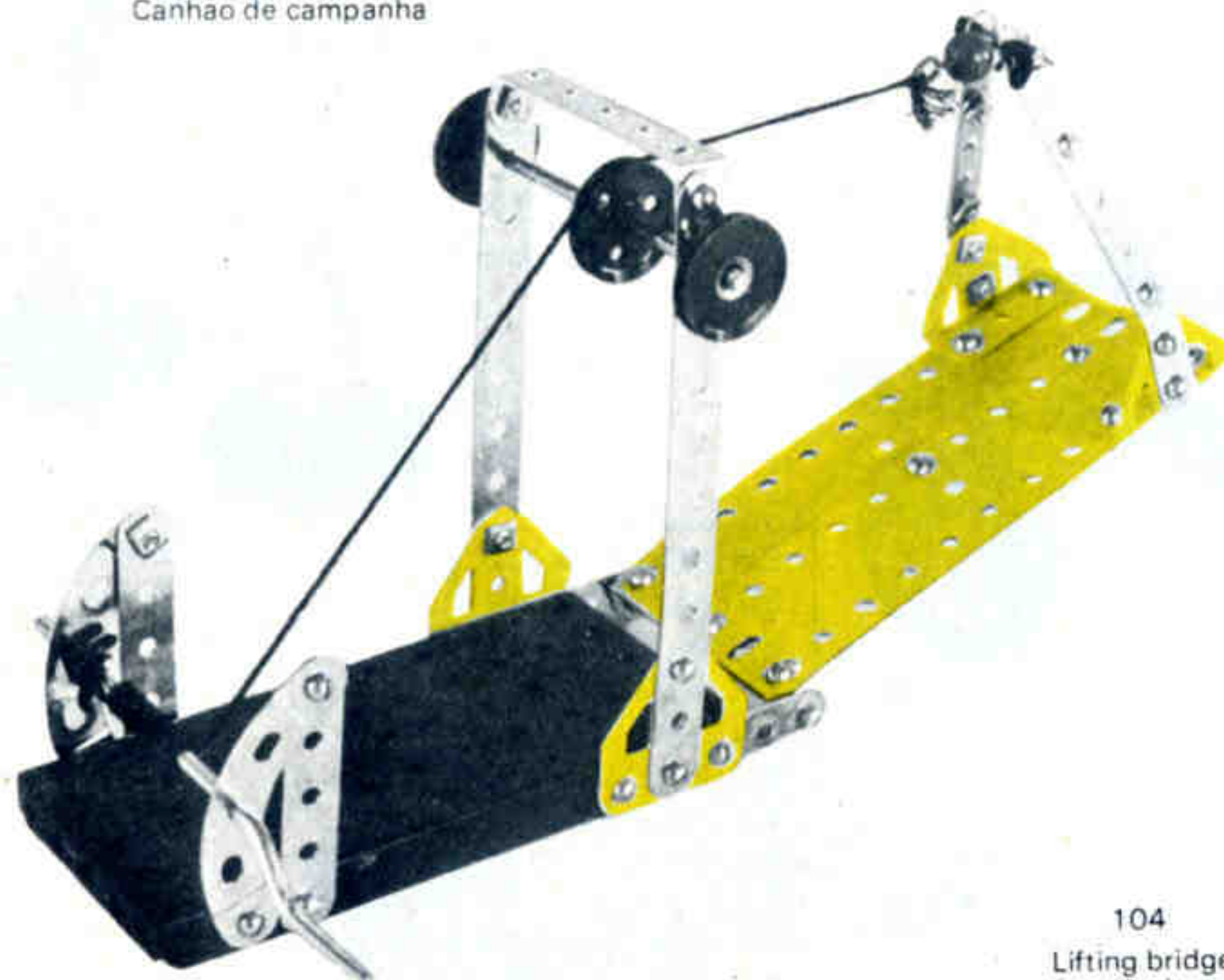

104

Lifting bridge  
Pont levis  
Ponte levatoio  
Zugbruecke  
Ponte levadiça

**PUENTE LEVADIZO  
/104**

- |          |
|----------|
| 4 - 2    |
| 4 - 5    |
| 1 - 16   |
| 1 - 18b  |
| 1 - 19s  |
| 2 - 22   |
| 1 - 22a  |
| 5 - 35   |
| 37 - 37a |
| 33 - 37b |
| 2 - 48a  |
| 1 - 52   |
| 1 - 57c  |
| 2 - 90a  |
| 2 - 111c |
| 2 - 126  |
| 2 - 126a |
| 2 - 199  |
| 4 - 235a |
| 1 - 40   |

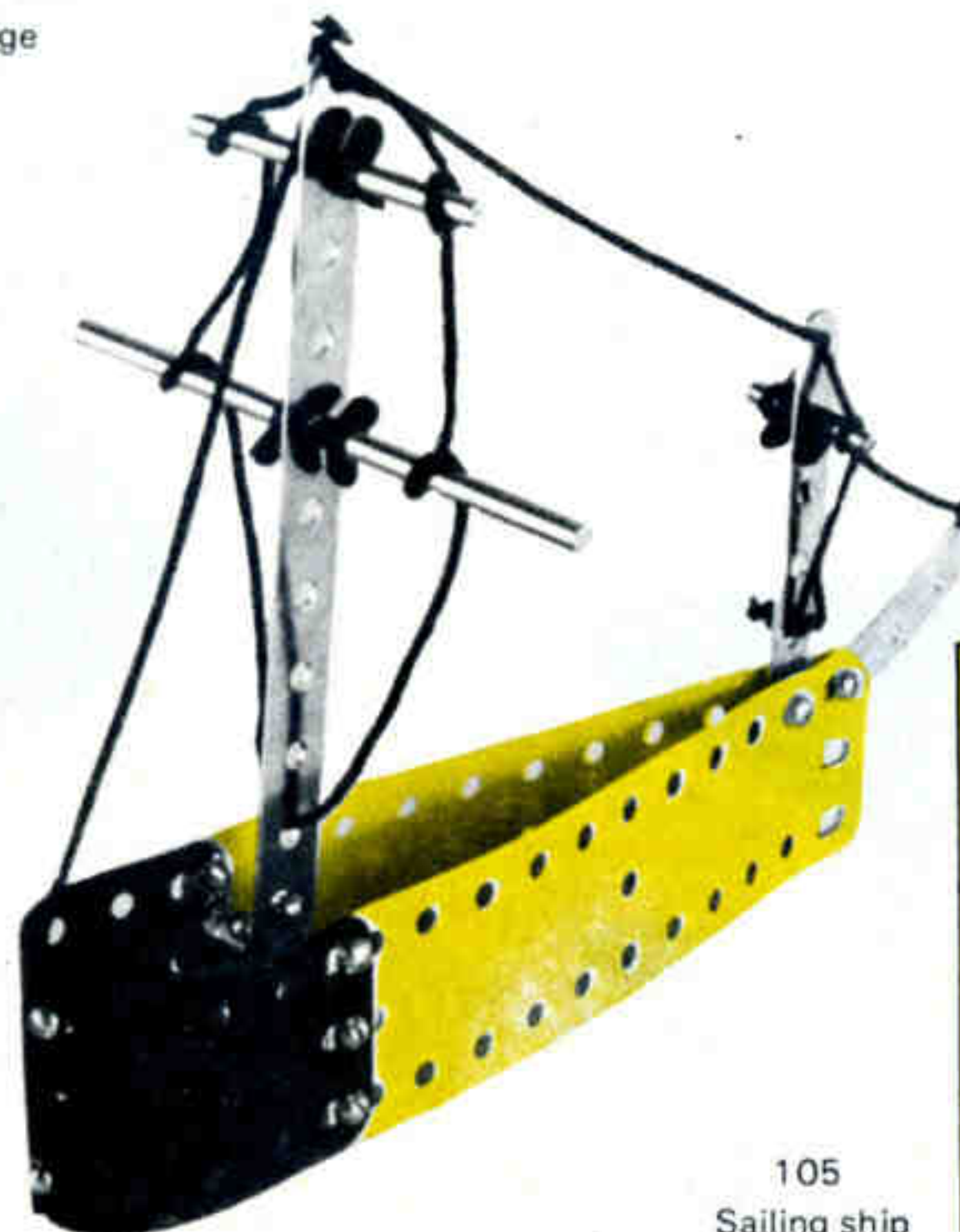

105

Sailing ship  
Voilier  
Veliero  
Klipper  
Veleiro

**VELERO 2/105**

- |          |
|----------|
| 1 - 2    |
| 1 - 10   |
| 2 - 12   |
| 1 - 16   |
| 1 - 17   |
| 1 - 18b  |
| 12 - 37b |
| 15 - 37a |
| 6 - 35   |
| 1 - 111c |
| 2 - 189  |
| 2 - 194  |
| 1 - 40   |



**CILINDRO  
ROTATORIO 2/106**

- 2 - 5
- 1 - 19s
- 3 - 22
- 1 - 24
- 16 - 37a
- 16 - 37b
- 2 - 48a
- 1 - 52
- 2 - 126
- 2 - 189

106

Rotating cylinder  
Cylindre rotatif  
Cilindro rotatorio  
Rotationszylinder  
Cilindro giratório

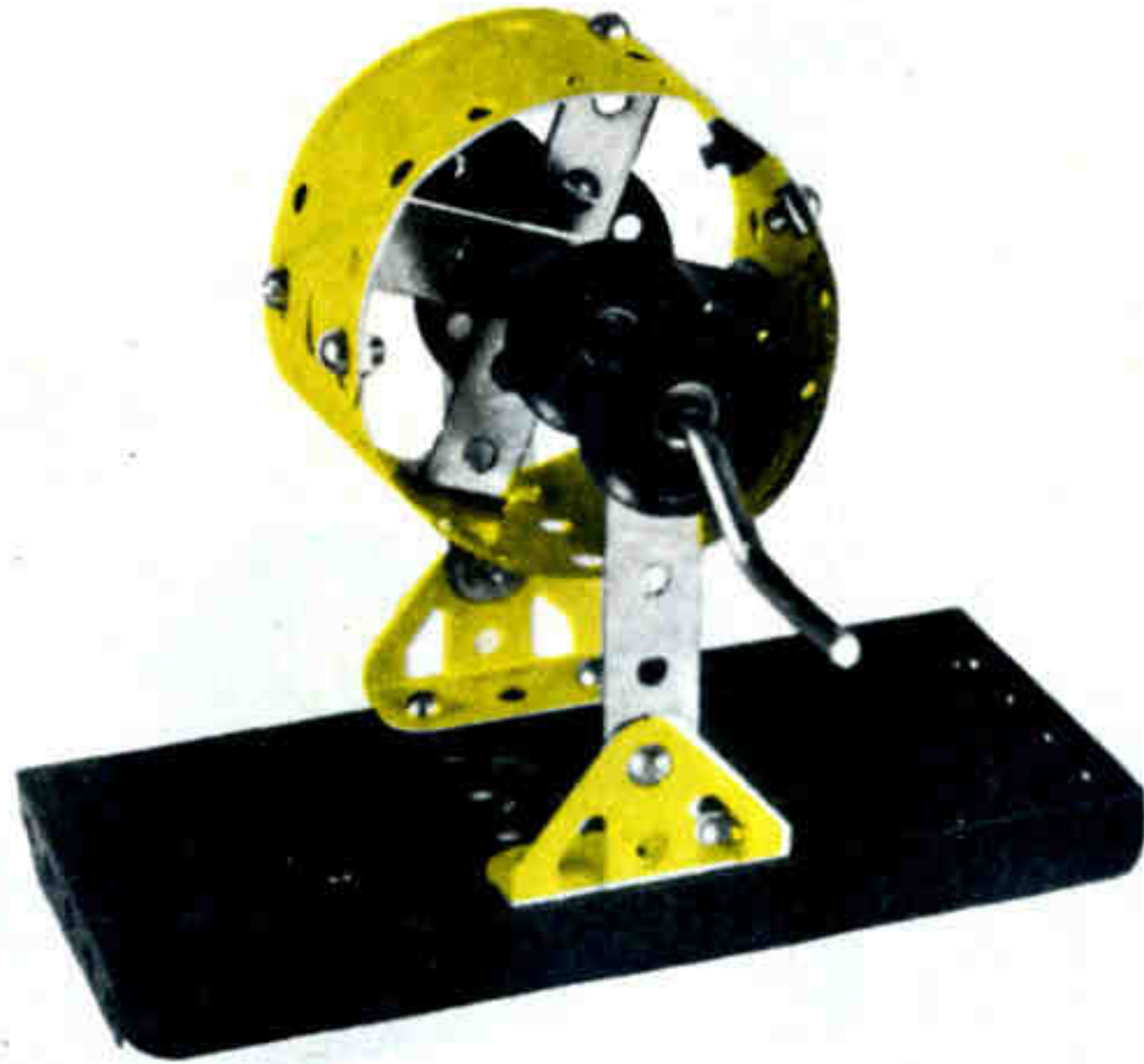

107  
Computer  
Computeur  
Computatrice  
Computer  
Computadora

**COMPUTADORA  
2/107**

- 1 - 16
- 4 - 22
- 1 - 24
- 13 - 37b
- 15 - 37a
- 1 - 48a
- 1 - 52
- 4 - 111c
- 1 - 125
- 2 - 126
- 2 - 142c
- 2 - 189
- 2 - 193
- 1 - 194
- 1 - 40

**TRINEO AUSTRIACO  
2/109**

- 3 - 2
- 4 - 5
- 4 - 10
- 1 - 11
- 4 - 12
- 27 - 37a
- 27 - 37b
- 1 - 48a
- 1 - 52
- 2 - 90a
- 1 - 126
- 2 - 193
- 2 - 194

109

Austrian sledge  
Traineau tyrolien  
Slitta austriaca  
Oesterreichischer  
Schlitten  
Trenó austriaco

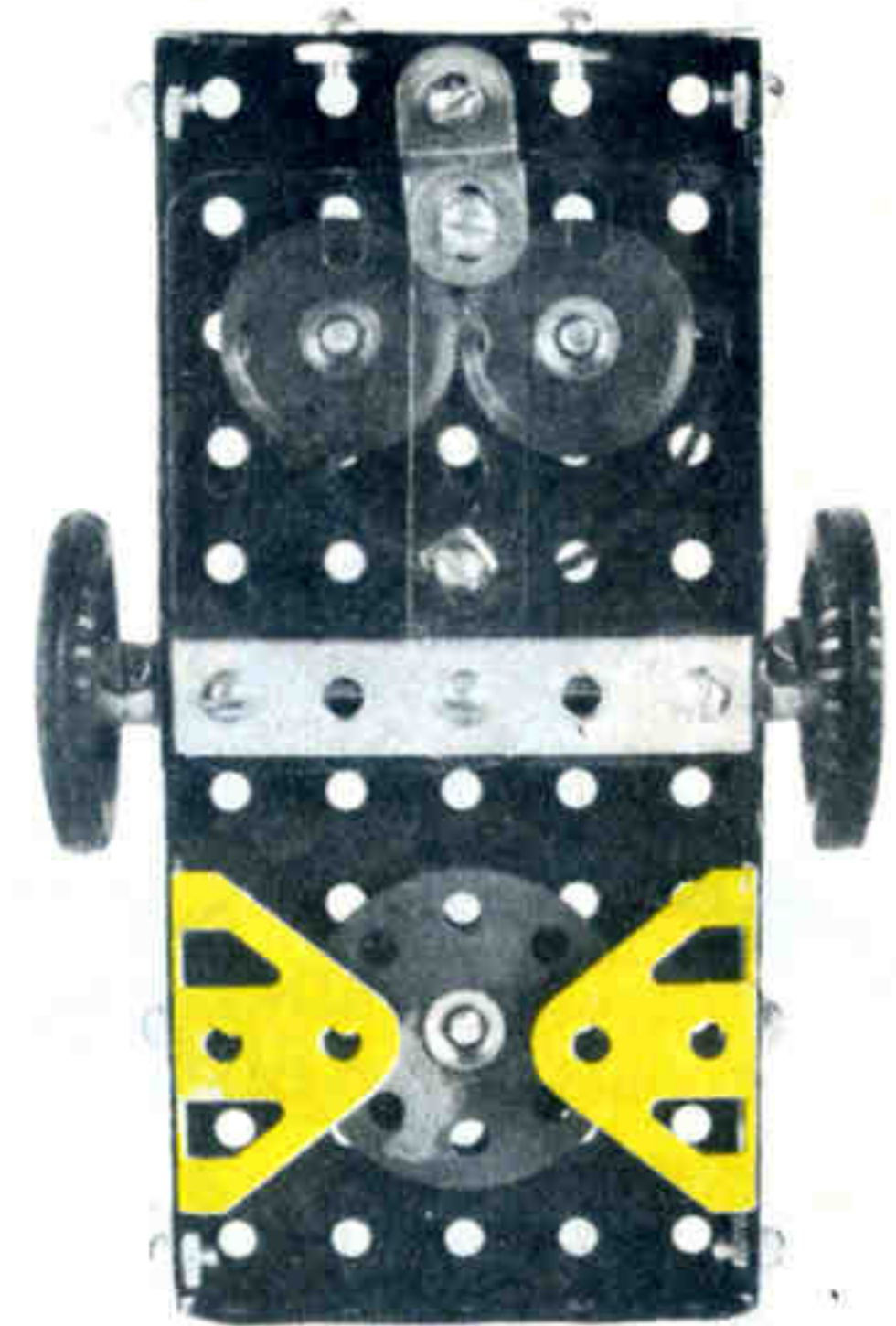

108  
School desk  
Bureau d'écolier  
Scrittoio collegio  
Schulpult  
Carteira colégio

**PUPITRE COLEGIO  
2/108**

- 4 - 5
- 4 - 12
- 1 - 16
- 2 - 35
- 14 - 37a
- 14 - 37b
- 2 - 48a
- 1 - 52
- 2 - 194
- 2 - 235a

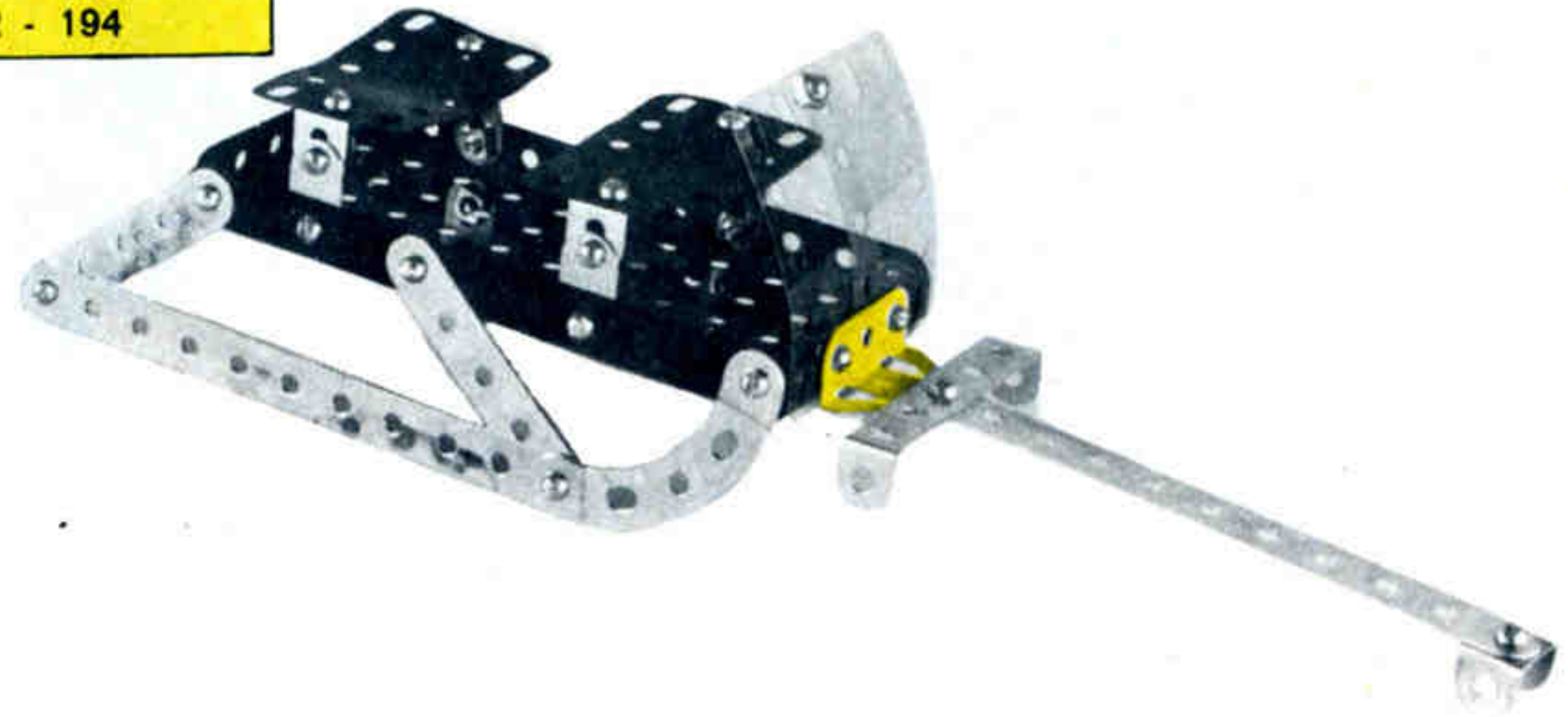
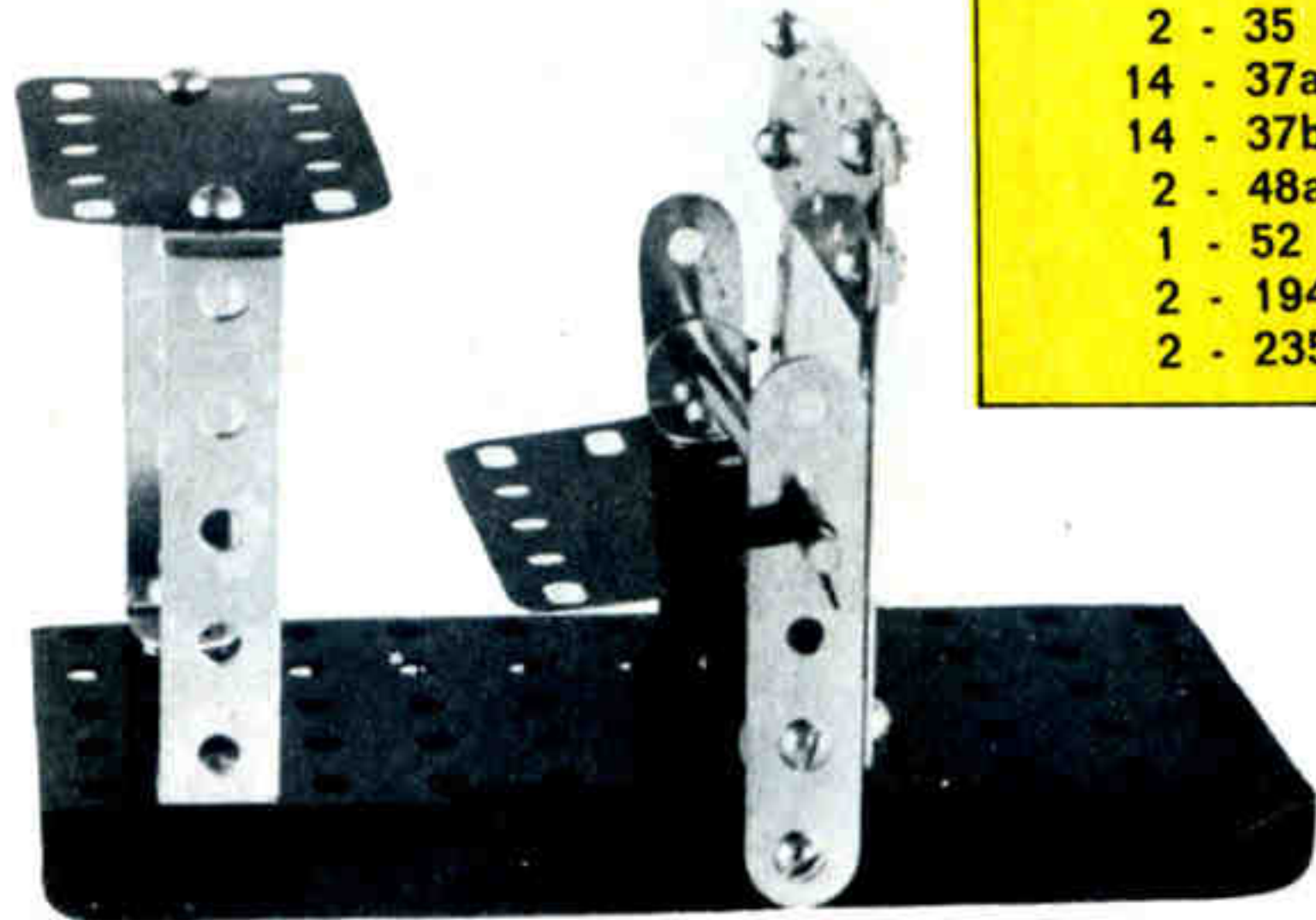

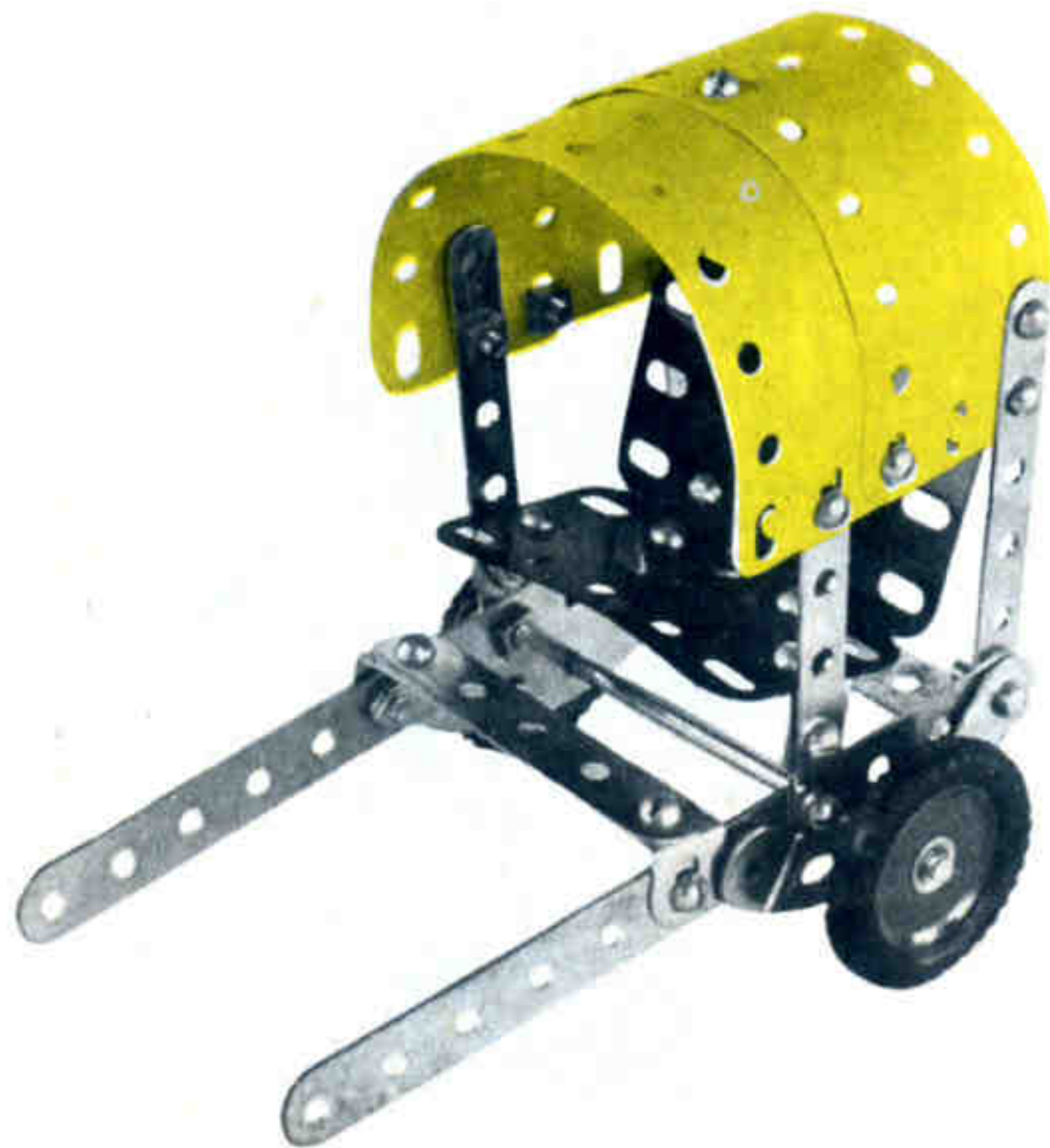

112  
Snow-plow  
Chasse neige  
Spazzaneve  
Schneepflug  
Limpa-neve

**QUITANIEVE 2/112**

- 1 - 10
- 1 - 11
- 6 - 12
- 2 - 16
- 1 - 17
- 2 - 18b
- 4 - 22
- 1 - 22a
- 2 - 35
- 20 - 37a
- 22 - 37b
- 5 - 38
- 1 - 52
- 1 - 111c
- 1 - 126
- 1 - 126a
- 4 - 142
- 1 - 156
- 1 - 189
- 2 - 194
- 2 - 235a

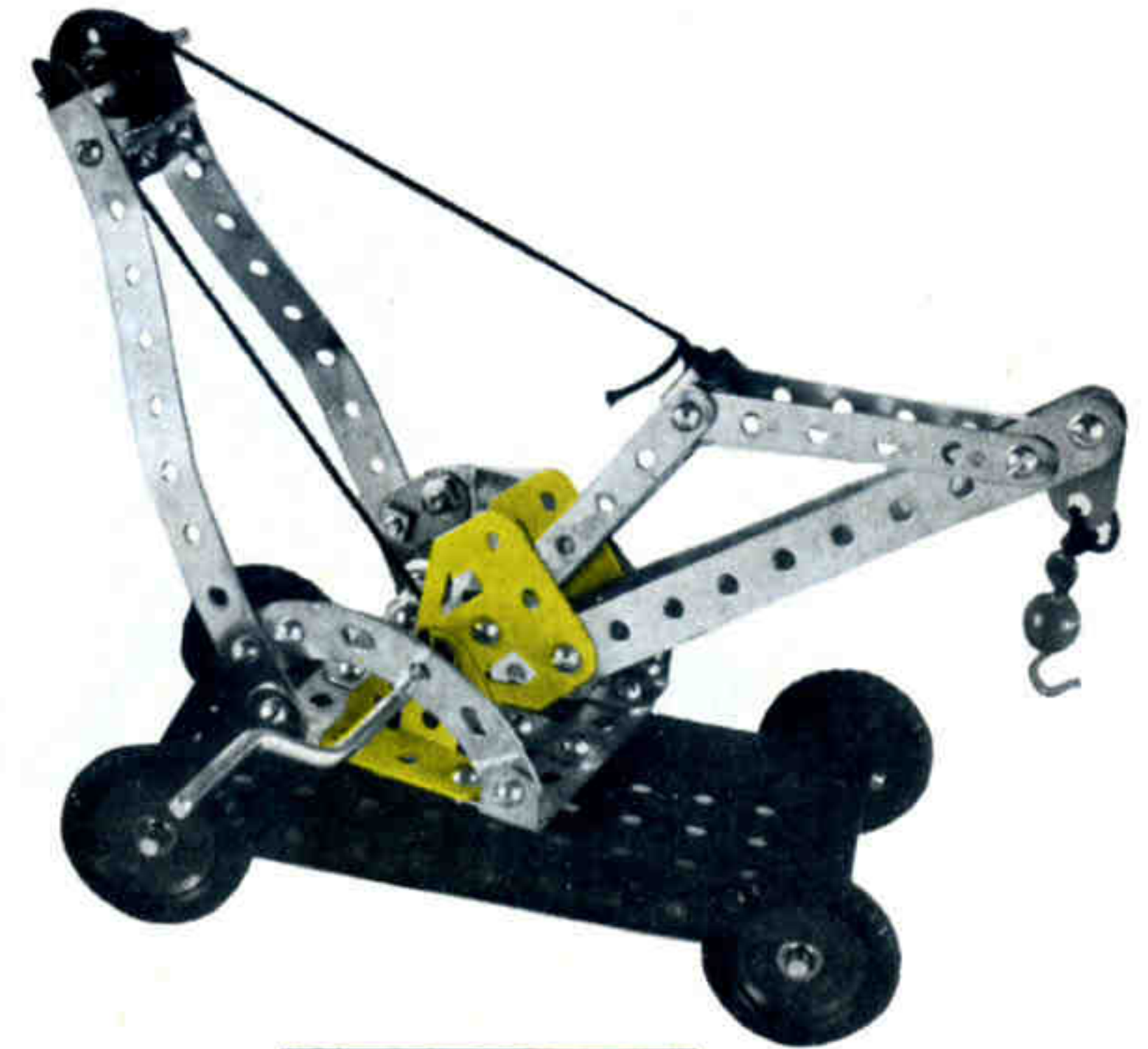

111  
Moveable crane  
Grue mobile  
Gru mobile  
Beweglicher Kran  
Guindaste móvel

**GRUA MOVIL 2/111**

- 4 - 2
- 3 - 5
- 4 - 10
- 1 - 11
- 2 - 12
- 1 - 19s
- 4 - 22
- 1 - 22a
- 1 - 24
- 6 - 35
- 32 - 37b
- 35 - 37a
- 6 - 38
- 2 - 48a
- 1 - 52
- 1 - 57c
- 2 - 90a
- 2 - 111c
- 2 - 126
- 2 - 126a
- 4 - 142c
- 4 - 235a

110  
Covered two-wheels  
carriage  
Cabriolet  
Tartana  
Zweiraedriger  
Planwagen  
Tartana

**TARTANA 2/110**

- 2 - 2
- 1 - 5
- 4 - 12
- 1 - 16
- 2 - 22
- 23 - 37b
- 25 - 37a
- 2 - 90a
- 2 - 111c
- 2 - 142c
- 2 - 189
- 2 - 194
- 4 - 235a

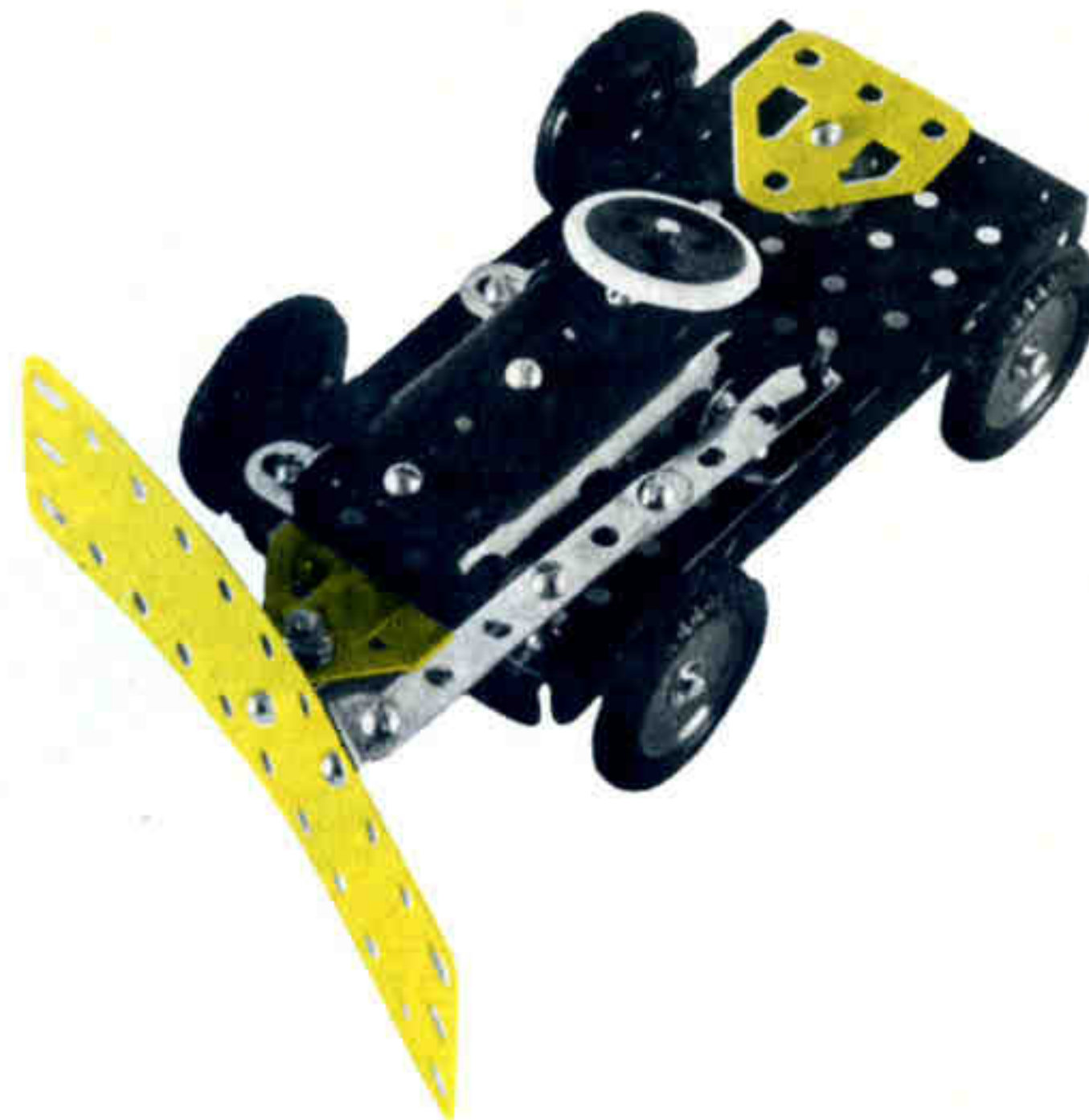

**VEHICULO  
HORQUILLA 2/113**

- 2 - 2
- 2 - 5
- 2 - 10
- 7 - 12
- 2 - 16
- 1 - 17
- 1 - 18b
- 2 - 22
- 1 - 22a
- 1 - 19s
- 6 - 35
- 32 - 37b
- 37 - 37a
- 2 - 48a
- 7 - 38
- 1 - 52
- 2 - 90a
- 4 - 111c
- 1 - 125
- 2 - 126
- 2 - 126a
- 2 - 142
- 2 - 193
- 2 - 194
- 4 - 235a
- 2 - 189

113  
Fork-lift truck  
Véhicule avec plate  
forme élévatrice  
Veicolo forcella  
Gabelstapler  
Veiculo empilhador

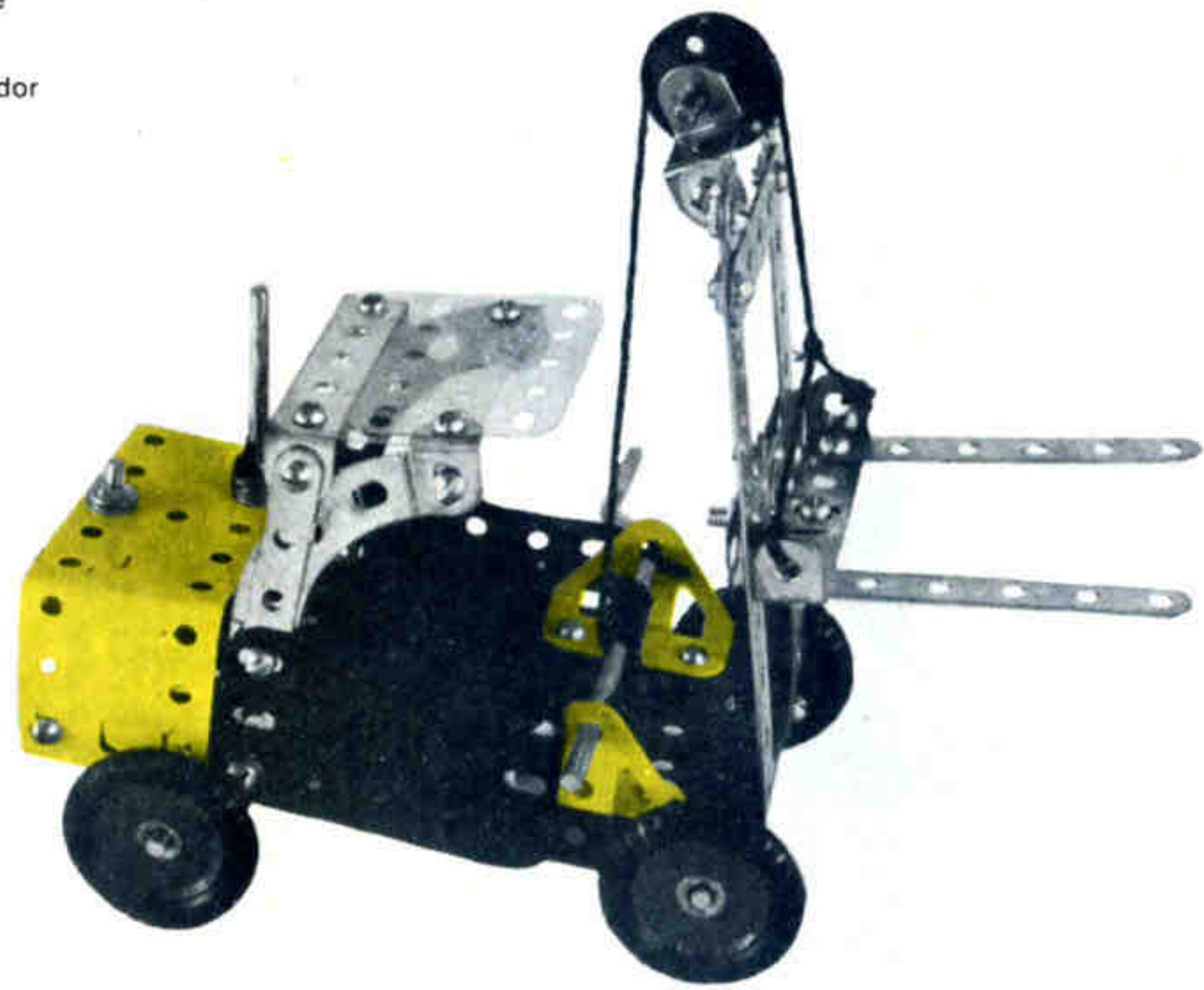

**SIERRA 2/115**

115  
Saw  
Scie mécanique  
Sega  
Blocksäge  
Serra

- 4 - 2
- 2 - 5
- 4 - 12
- 2 - 16
- 1 - 19s
- 2 - 22
- 6 - 35
- 18 - 37b
- 20 - 37a
- 2 - 38
- 2 - 48a
- 1 - 52
- 1 - 111c
- 2 - 126
- 1 - 189
- 1 - 194

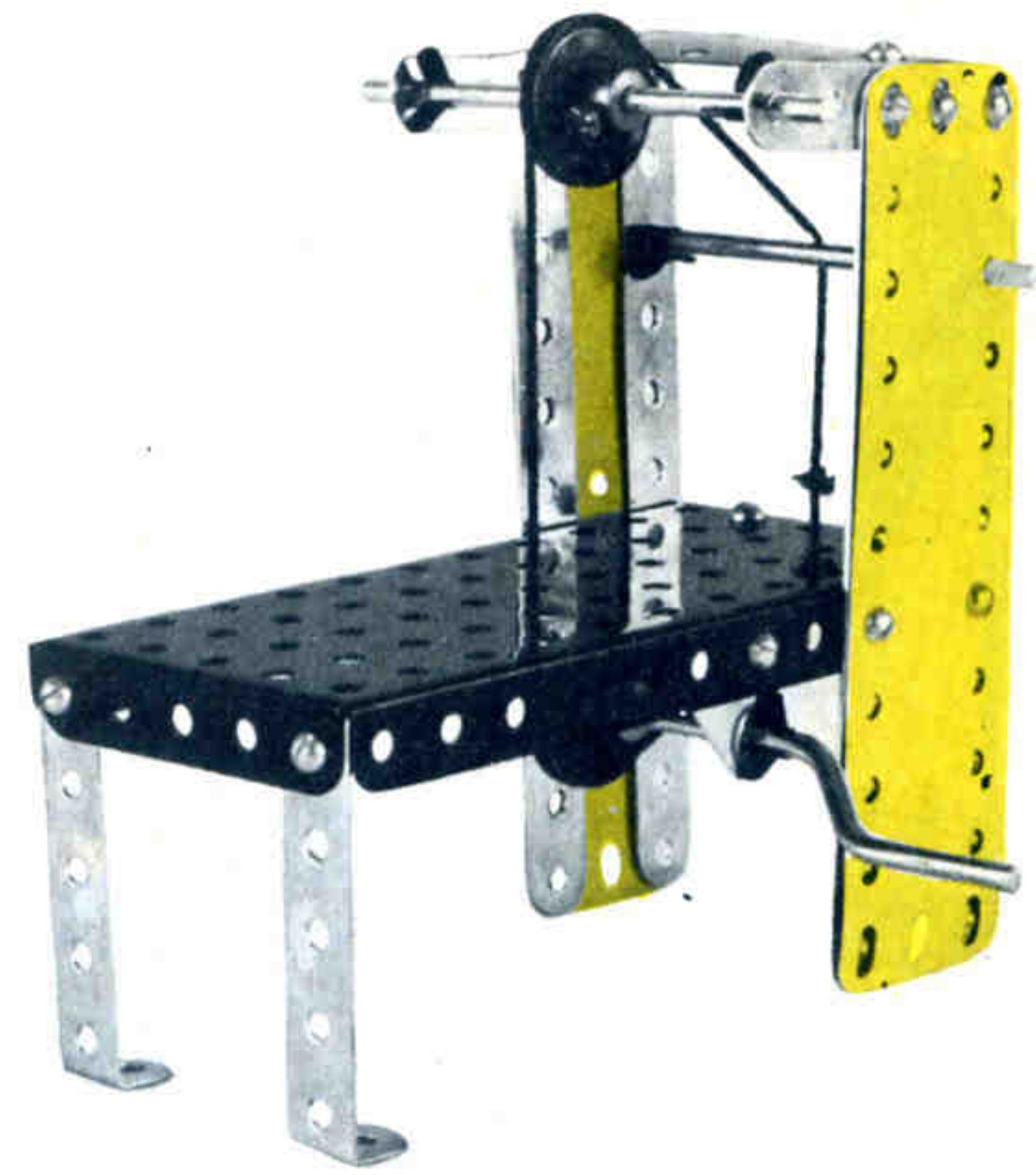

**BATERIA 2/114**

- 2 - 5
- 3 - 12
- 2 - 17
- 3 - 22
- 1 - 22a
- 2 - 35
- 16 - 37b
- 19 - 37a
- 1 - 48a
- 1 - 52
- 2 - 111c
- 2 - 126
- 1 - 126a
- 2 - 142c
- 1 - 155
- 2 - 189
- 2 - 235a

114  
Battery  
Batterie  
Bateria  
Batterie  
Bateria



**GRUA MOVIL**

2/116

- 2 - 2
- 1 - 11
- 2 - 16
- 1 - 18b
- 1 - 19s
- 4 - 22
- 2 - 22a
- 5 - 35
- 8 - 37b
- 11 - 37a
- 2 - 48a
- 1 - 52
- 1 - 57c
- 2 - 90a
- 2 - 111c
- 4 - 142c
- 2 - 155
- 2 - 235a

116  
 Moveable crane  
 Grue mobile  
 Gru Mobile  
 Beweglicher Kran  
 Guindaste móvil

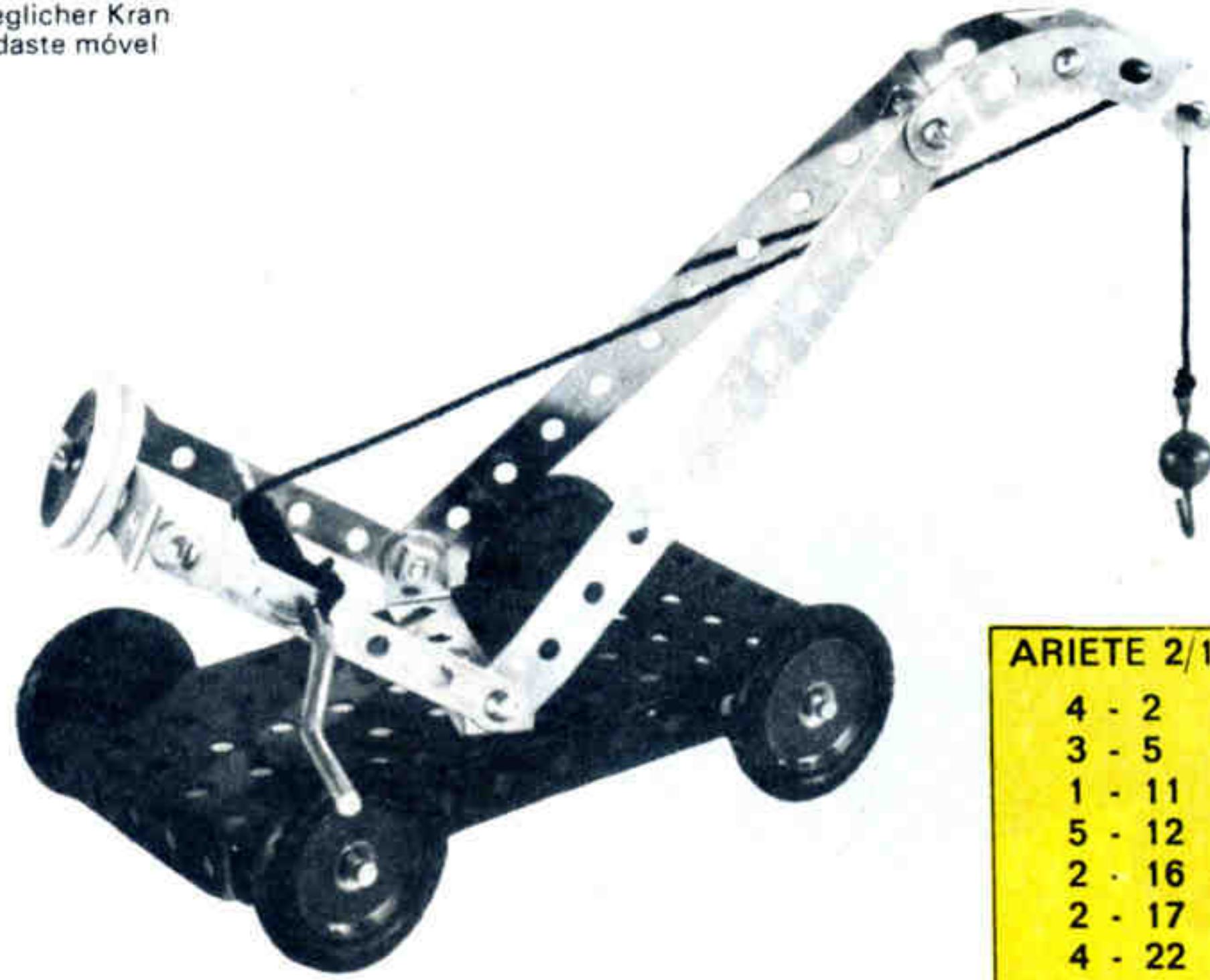

**ARIETE 2/118**

- 4 - 2
- 3 - 5
- 1 - 11
- 5 - 12
- 2 - 16
- 2 - 17
- 4 - 22
- 32 - 37a
- 35 - 37b
- 4 - 38
- 2 - 48a
- 1 - 52
- 2 - 90a
- 1 - 111c
- 2 - 189
- 1 - 194
- 2 - 235a

118  
 Bettering-ram  
 Bêlier  
 Ariete  
 Ramme  
 Ariete

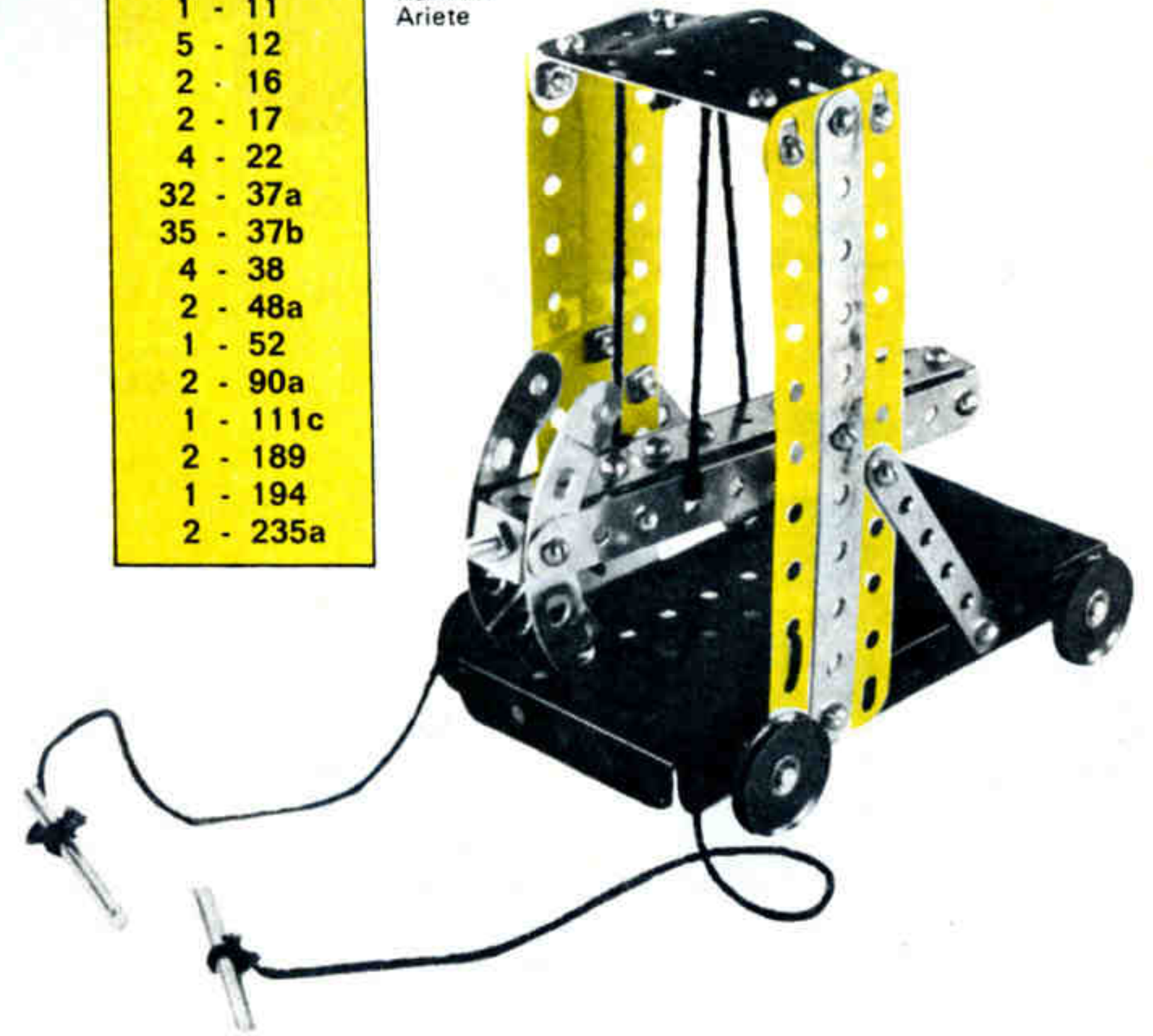

**AVION 2/117**

- 4 - 2
- 4 - 5
- 2 - 12
- 1 - 22
- 1 - 24
- 25 - 37a
- 25 - 37b
- 2 - 48a
- 2 - 126
- 1 - 126a
- 1 - 142c
- 2 - 189
- 2 - 193
- 2 - 194
- 2 - 235a

117  
 Plane  
 Avion  
 Aereo  
 Flugzeug  
 Aviao

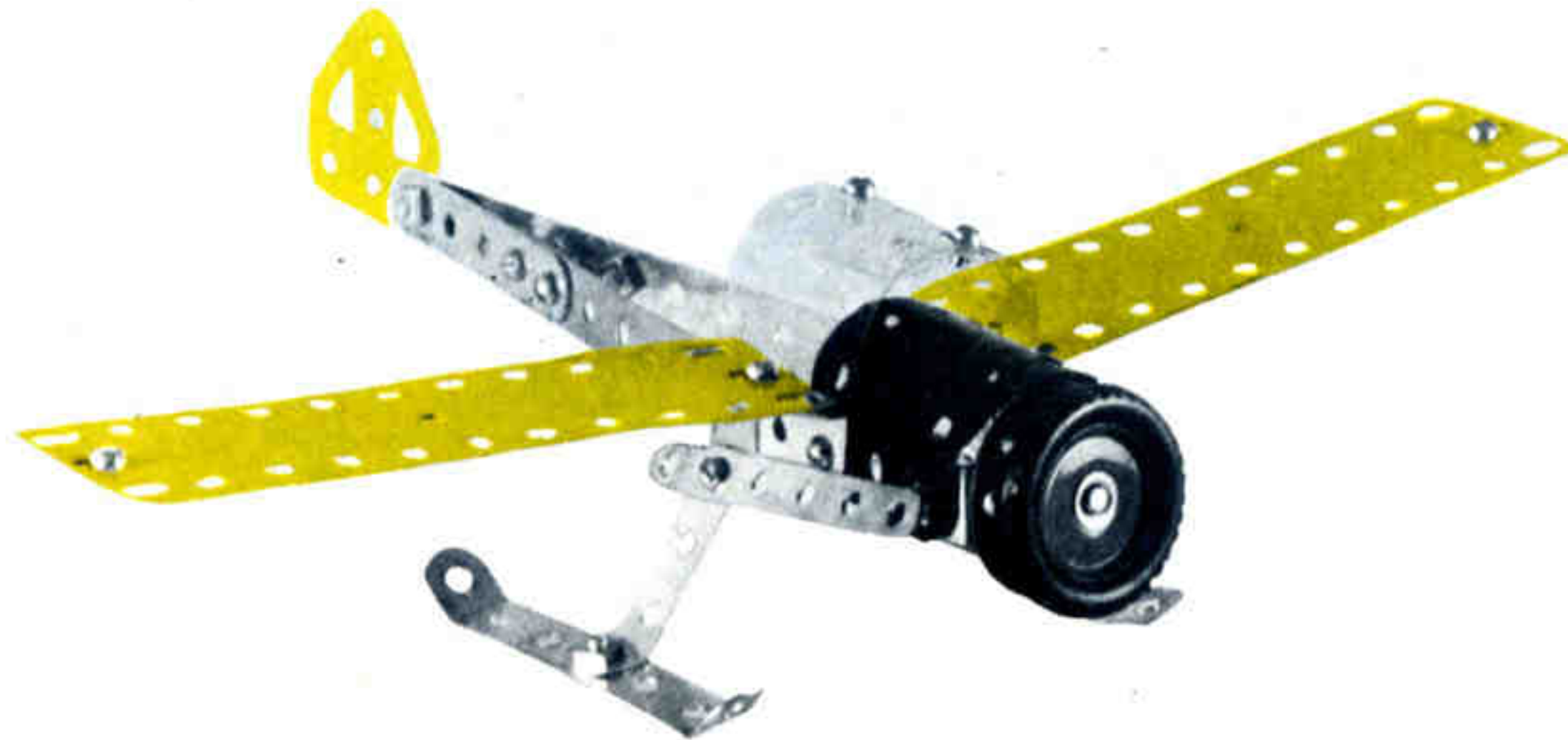

119

Assaulting tower  
Tour d'assaut  
Torre d'assalto  
Angriffsturm  
Torre de assalto

**TORRE DE ASALTO**

2/119

4 - 2  
4 - 5  
8 - 12  
2 - 16  
2 - 17  
4 - 22  
27 - 37a  
31 - 37b  
4 - 38  
2 - 48a  
1 - 52  
2 - 194  
4 - 235a

120

Machine gun  
Mitrailleuse  
Mitragliatrice  
Maschinengewehr  
Metralhadora

**AMETRALLADORA**

2/120

3 - 2  
1 - 11  
8 - 12  
1 - 16  
1 - 17  
1 - 24  
3 - 35  
31 - 37a  
27 - 37b  
7 - 38  
1 - 52  
2 - 90a  
3 - 111c  
1 - 126a  
2 - 194  
1 - 213  
3 - 235a

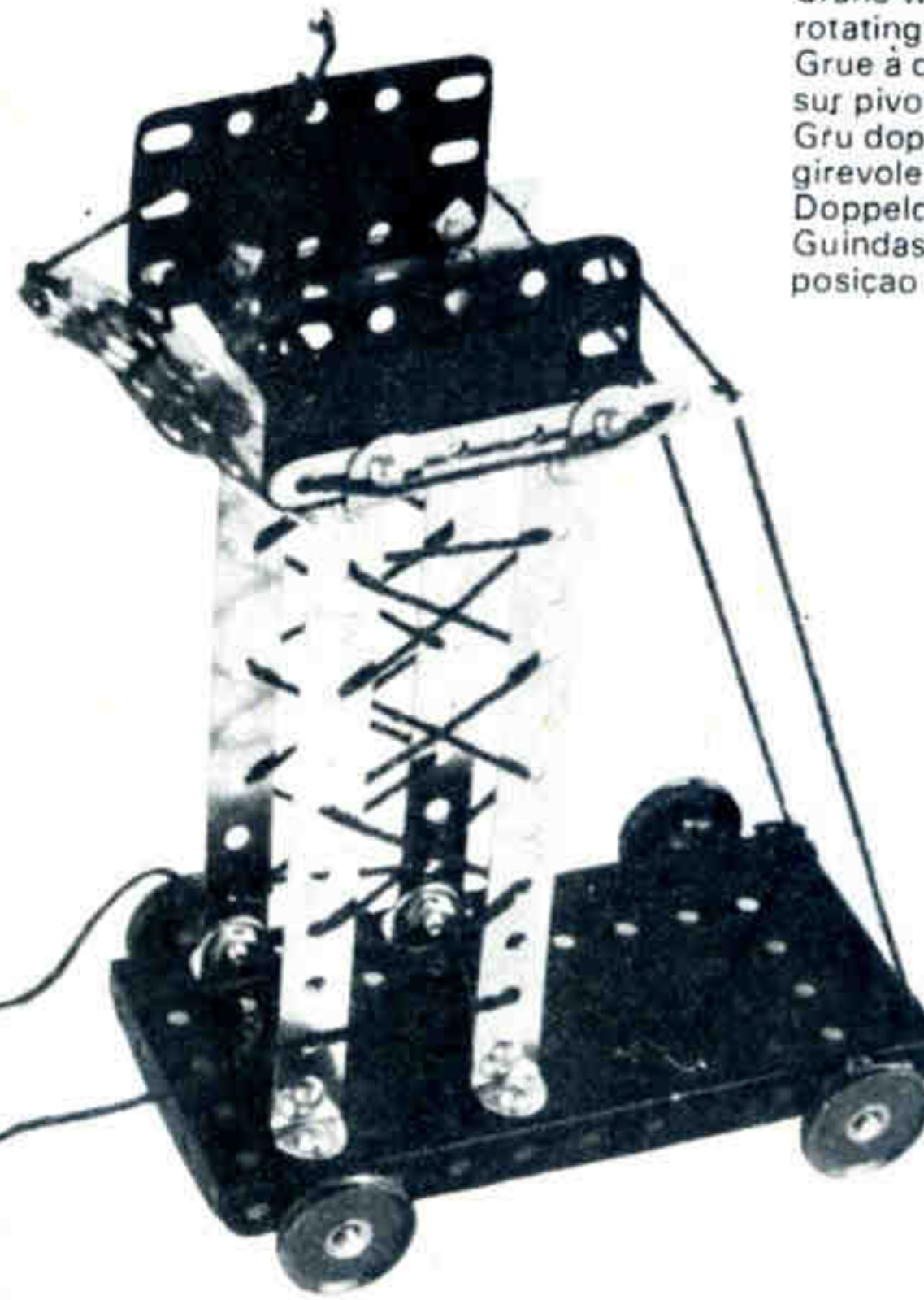

121

Crane with double  
rotating position  
Grue à double position  
sur pivot  
Gru doppia posizione  
girevole  
Doppeldrehkran  
Guindaste doble  
posição giratório

**GRUA  
DOBLE POSICION  
GIRATORIA 2/121**

2 - 2  
3 - 5  
8 - 12  
1 - 16  
2 - 17  
1 - 18b  
1 - 19s  
4 - 22  
1 - 24  
2 - 35  
23 - 37a  
28 - 37b  
8 - 38  
2 - 48a  
1 - 52  
1 - 57c  
1 - 125  
2 - 126  
2 - 126a  
2 - 194  
3 - 235a

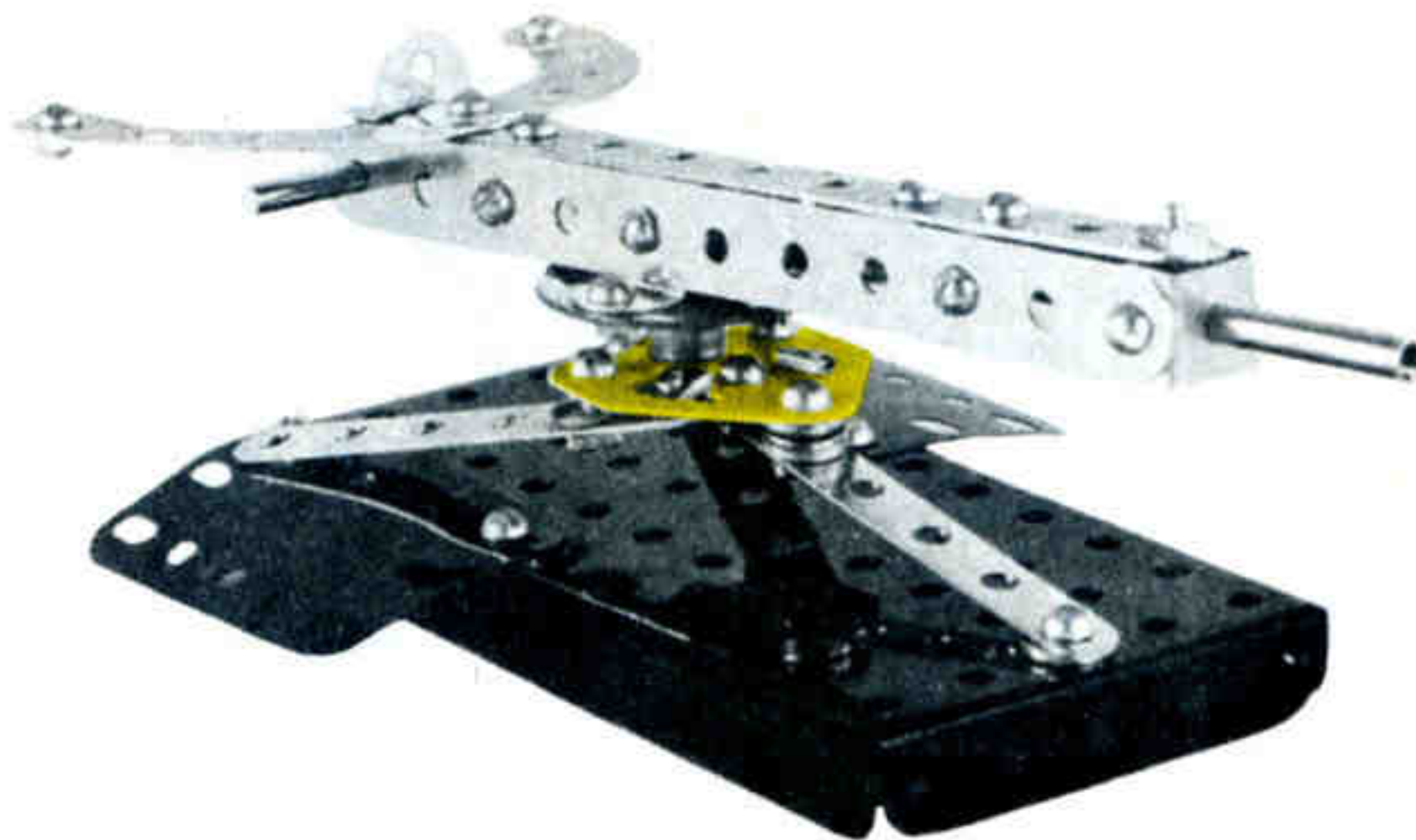
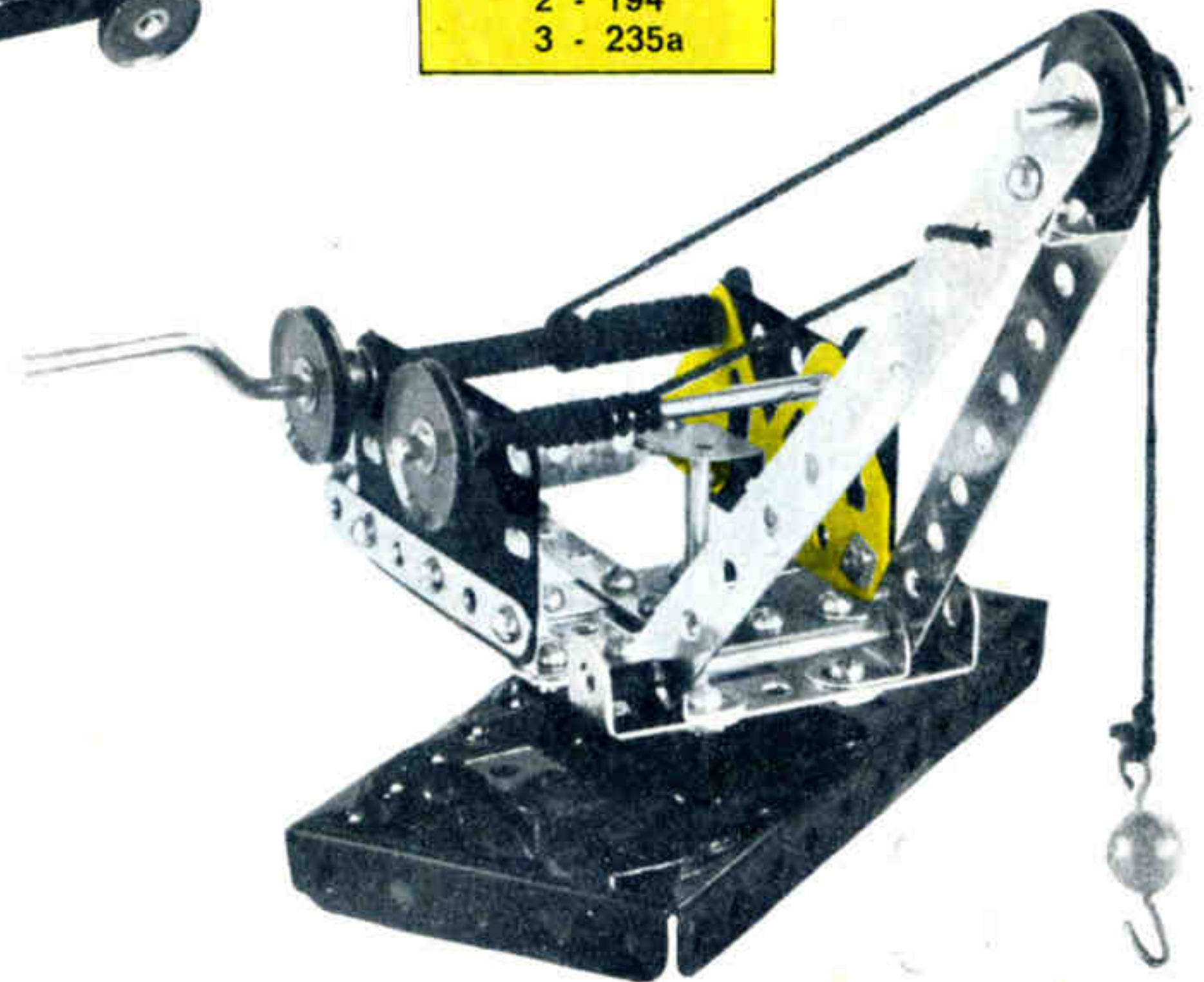

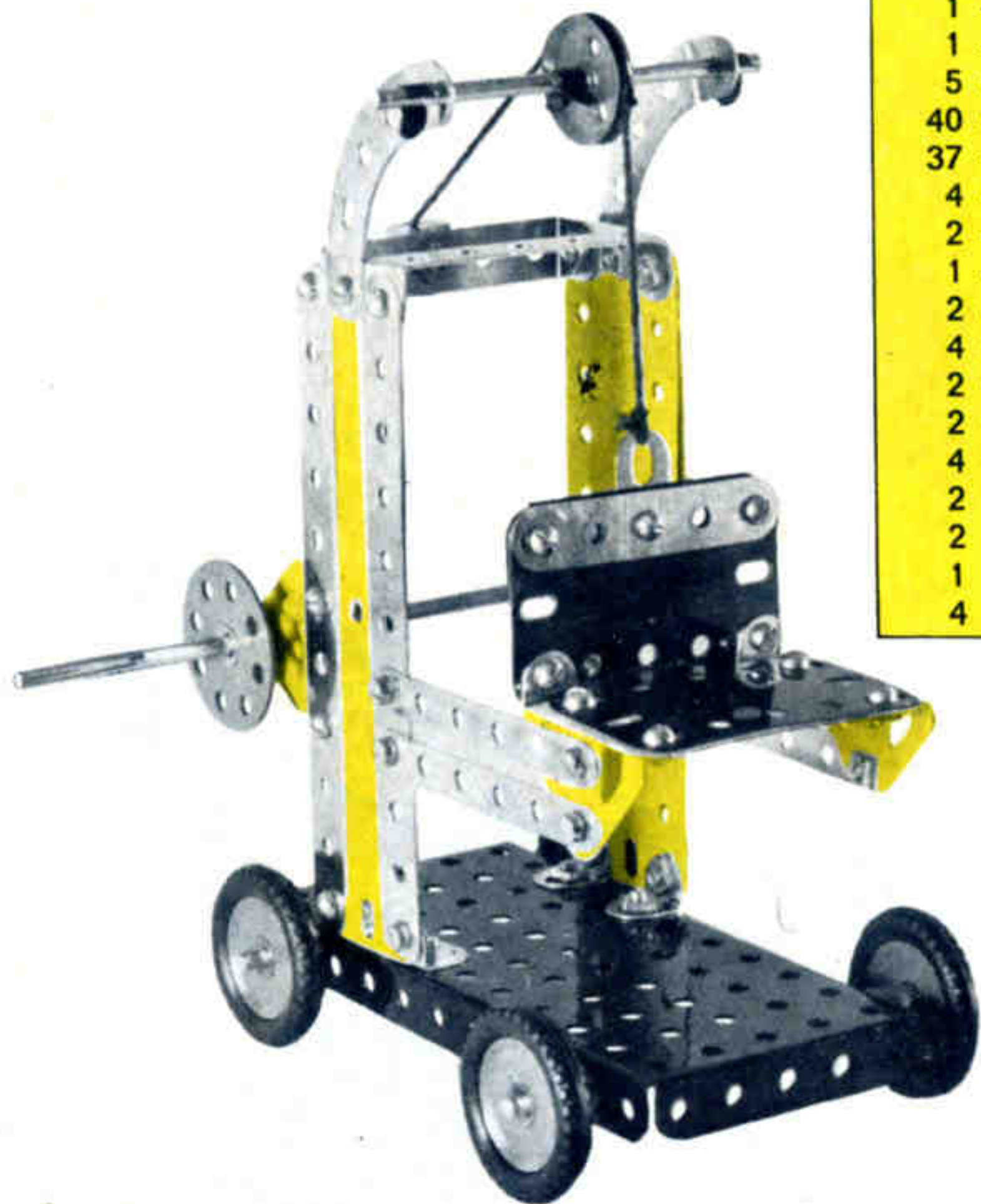

**ELEVADOR DE CARGA 2/122**

- 4 - 2
- 1 - 5
- 1 - 10
- 6 - 12
- 2 - 16
- 2 - 17
- 1 - 19s
- 4 - 22
- 1 - 22a
- 1 - 24
- 5 - 35
- 40 - 37a
- 37 - 37b
- 4 - 38
- 2 - 48a
- 1 - 52
- 2 - 90a
- 4 - 111c
- 2 - 126
- 2 - 126a
- 4 - 142c
- 2 - 193
- 2 - 194
- 1 - 213
- 4 - 235a

122

Load lift  
 Elévateur de charge  
 Elevatore di carico  
 Lastaufzug  
 Elevador de carga

124

Moveable road roller  
 Rouleau  
 Spianatrice stradale  
 mobile  
 Strassenwalze  
 Cilindro compressor

**APISONADORA MOVIL 2/124**

- 3 - 10
- 2 - 12
- 2 - 22
- 2 - 22a
- 1 - 24
- 1 - 16
- 1 - 17
- 5 - 35
- 19 - 37b
- 22 - 37a
- 2 - 90a
- 1 - 111c
- 2 - 126
- 2 - 126a
- 2 - 142
- 2 - 155
- 2 - 189
- 3 - 235a

123

Anti-aircraft  
 Canon anti aérien  
 Antiaereo  
 Flugabwehrgeschuetz  
 Antiaéreo

**ANTIAEREO 2/123**

- 2 - 5
- 2 - 10
- 4 - 12
- 2 - 16
- 1 - 17
- 1 - 18b
- 1 - 19s
- 2 - 22
- 1 - 24
- 5 - 35
- 26 - 37a
- 25 - 37b
- 3 - 38
- 2 - 48a
- 1 - 52
- 2 - 90a
- 2 - 111c
- 1 - 125
- 2 - 126
- 2 - 126a
- 2 - 194
- 1 - 213
- 2 - 235a



**HELICOPTERO**  
2/125

|    |   |      |
|----|---|------|
| 4  | - | 2    |
| 2  | - | 5    |
| 4  | - | 10   |
| 1  | - | 11   |
| 8  | - | 12   |
| 1  | - | 16   |
| 1  | - | 18b  |
| 1  | - | 24   |
| 4  | - | 35   |
| 38 | - | 37a  |
| 35 | - | 37b  |
| 3  | - | 38   |
| 2  | - | 48a  |
| 2  | - | 90a  |
| 4  | - | 111c |
| 1  | - | 125  |
| 1  | - | 126  |
| 2  | - | 126a |
| 2  | - | 194  |
| 4  | - | 235a |

125  
Helicopter  
Helicoptère  
Elicottero  
Hubschrauber  
Helicóptero

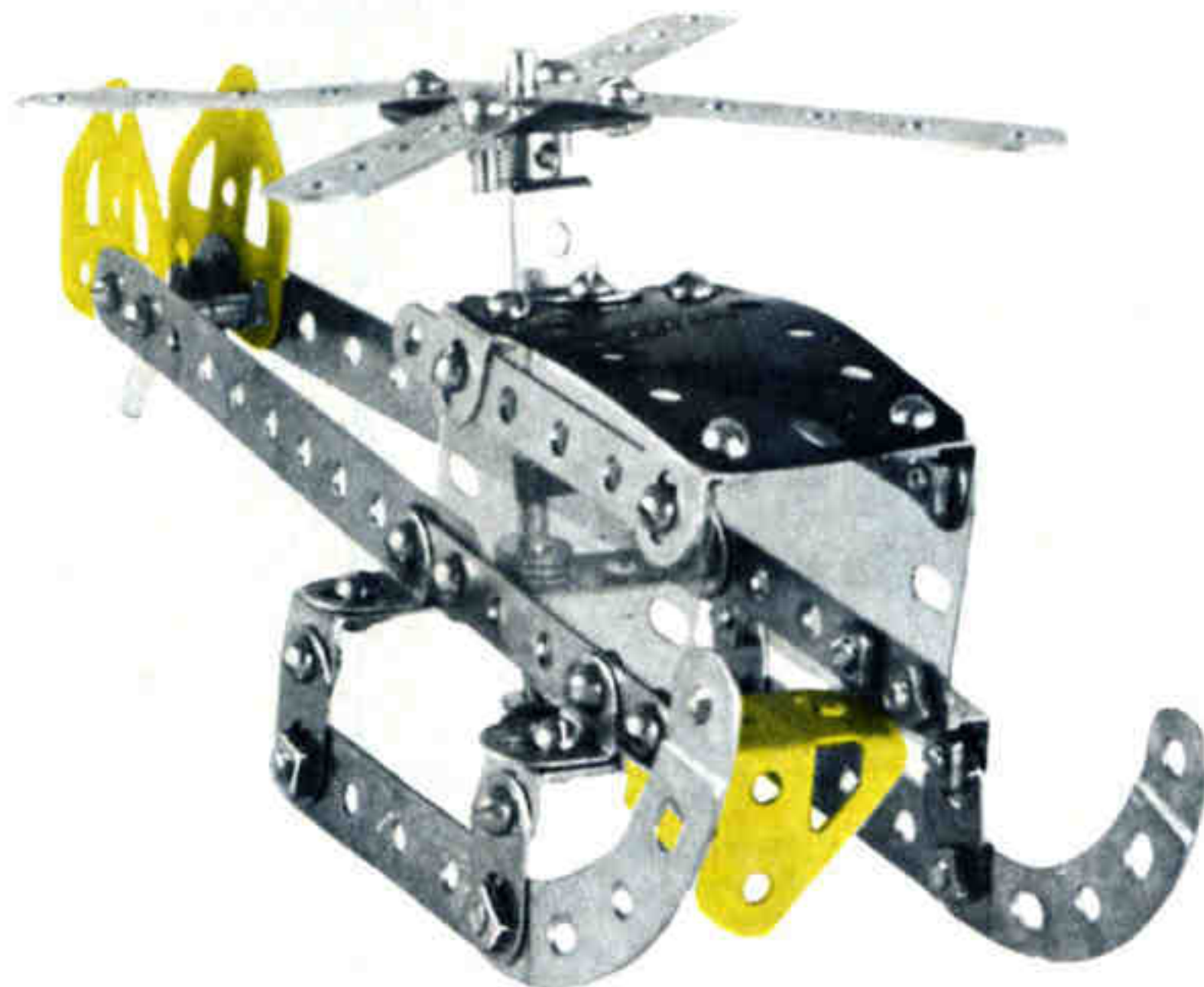
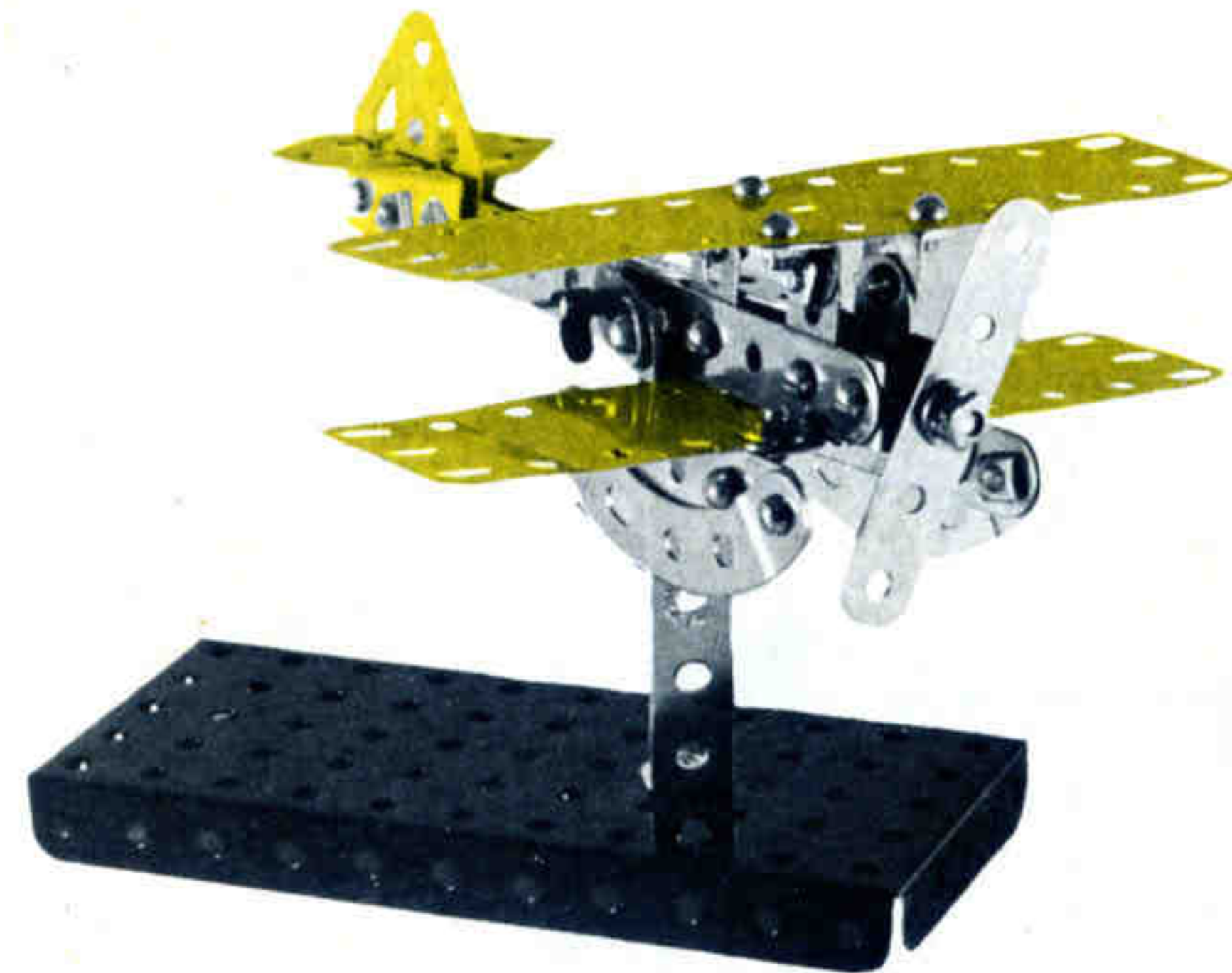

**BIPLANO 2/126**

|    |   |      |
|----|---|------|
| 2  | - | 2    |
| 3  | - | 5    |
| 4  | - | 10   |
| 1  | - | 11   |
| 8  | - | 12   |
| 1  | - | 18b  |
| 2  | - | 35   |
| 32 | - | 37a  |
| 28 | - | 37b  |
| 6  | - | 38   |
| 1  | - | 48a  |
| 1  | - | 52   |
| 2  | - | 90a  |
| 3  | - | 111c |
| 1  | - | 125  |
| 2  | - | 126  |
| 1  | - | 126a |
| 2  | - | 189  |
| 1  | - | 235a |

126  
Byplane  
Biplan  
Biplano  
Doppeldecker  
Biplano

127

Roundabaout  
Manège  
Carosello da fiera  
Schwinge  
Carrocel

**TIOVIVO /127**

- 4 - 2
- 4 - 5
- 8 - 12
- 1 - 16
- 1 - 19s
- 4 - 22
- 2 - 22a
- 1 - 24
- 5 - 35
- 36 - 37a
- 37 - 37b
- 4 - 38
- 2 - 48a
- 1 - 52
- 2 - 90a
- 4 - 111c
- 2 - 126
- 2 - 126a
- 2 - 142c
- 1 - 193
- 2 - 194
- 3 - 235a

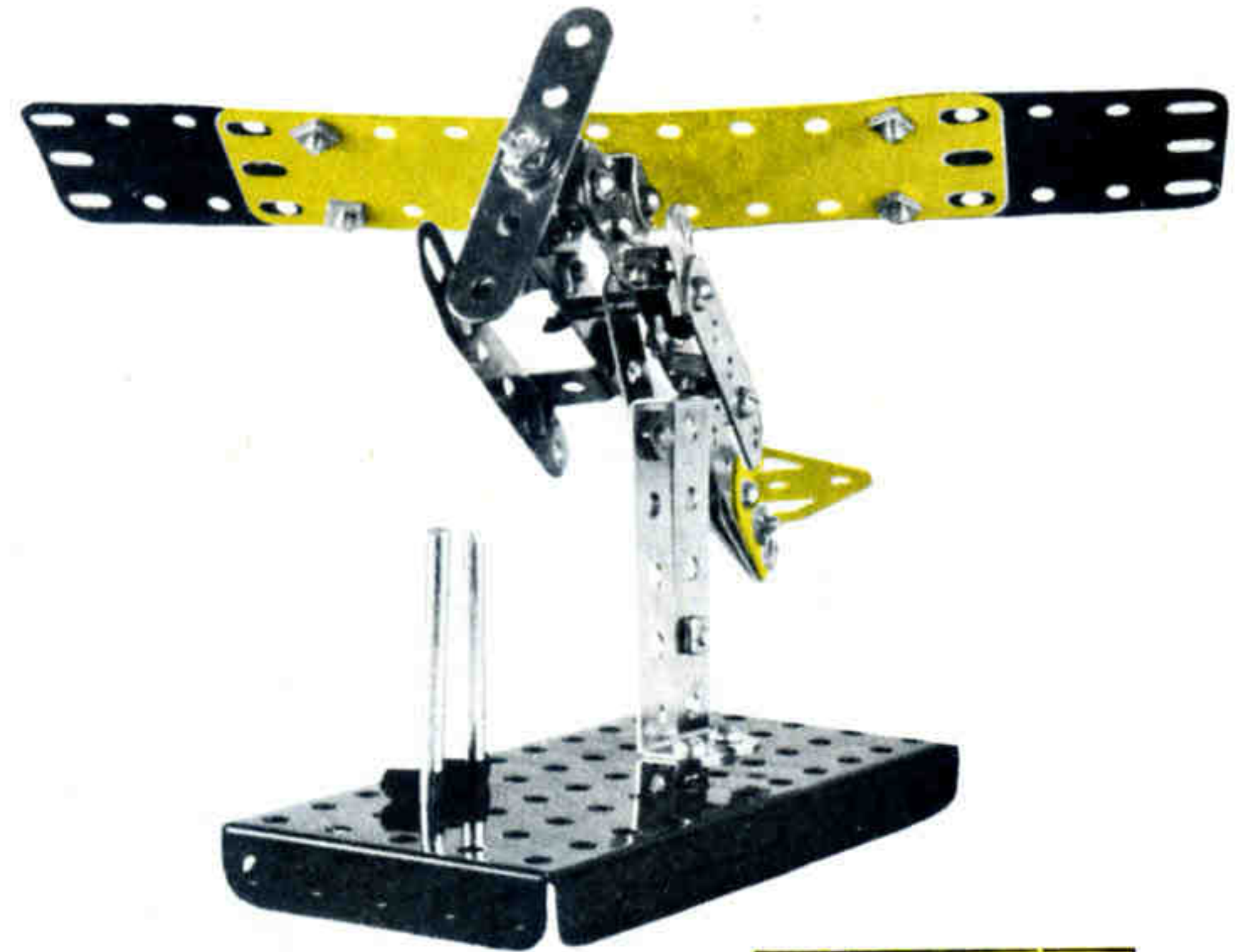

**HIDROAVION 2, 128**

- 2 - 2
- 3 - 5
- 4 - 10
- 2 - 11
- 8 - 12
- 2 - 17
- 1 - 18b
- 6 - 35
- 32 - 37a
- 29 - 37b
- 2 - 38
- 2 - 48a
- 1 - 52
- 1 - 111c
- 1 - 125
- 2 - 126a
- 1 - 189
- 2 - 194
- 1 - 235a

128

Hydroplane  
Hydroavion  
Idrovolante  
Wasserflugzeug  
Hidroaviao



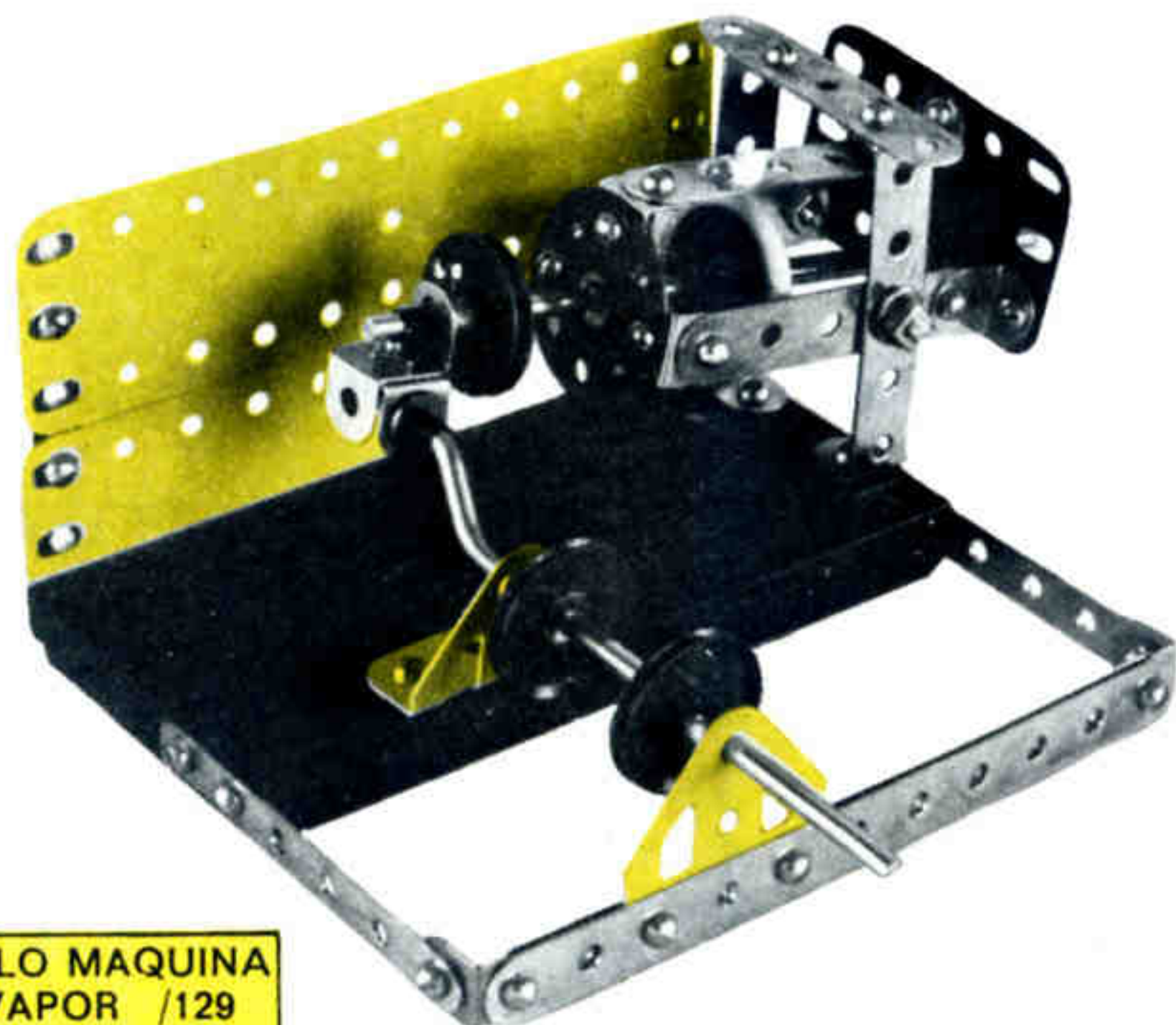

130

Double percussion  
machine  
Appareil à double  
percussion  
Macchina di doppia  
percussione  
Doppelklopfmaschine  
Máquina de doble  
percussao

#### MAQUINA DE DOBLE PERCUSION 2/130

2 - 2  
4 - 12  
1 - 16  
2 - 35  
24 - 37a  
24 - 37b  
2 - 48a  
1 - 52  
2 - 90a  
2 - 126a  
2 - 194

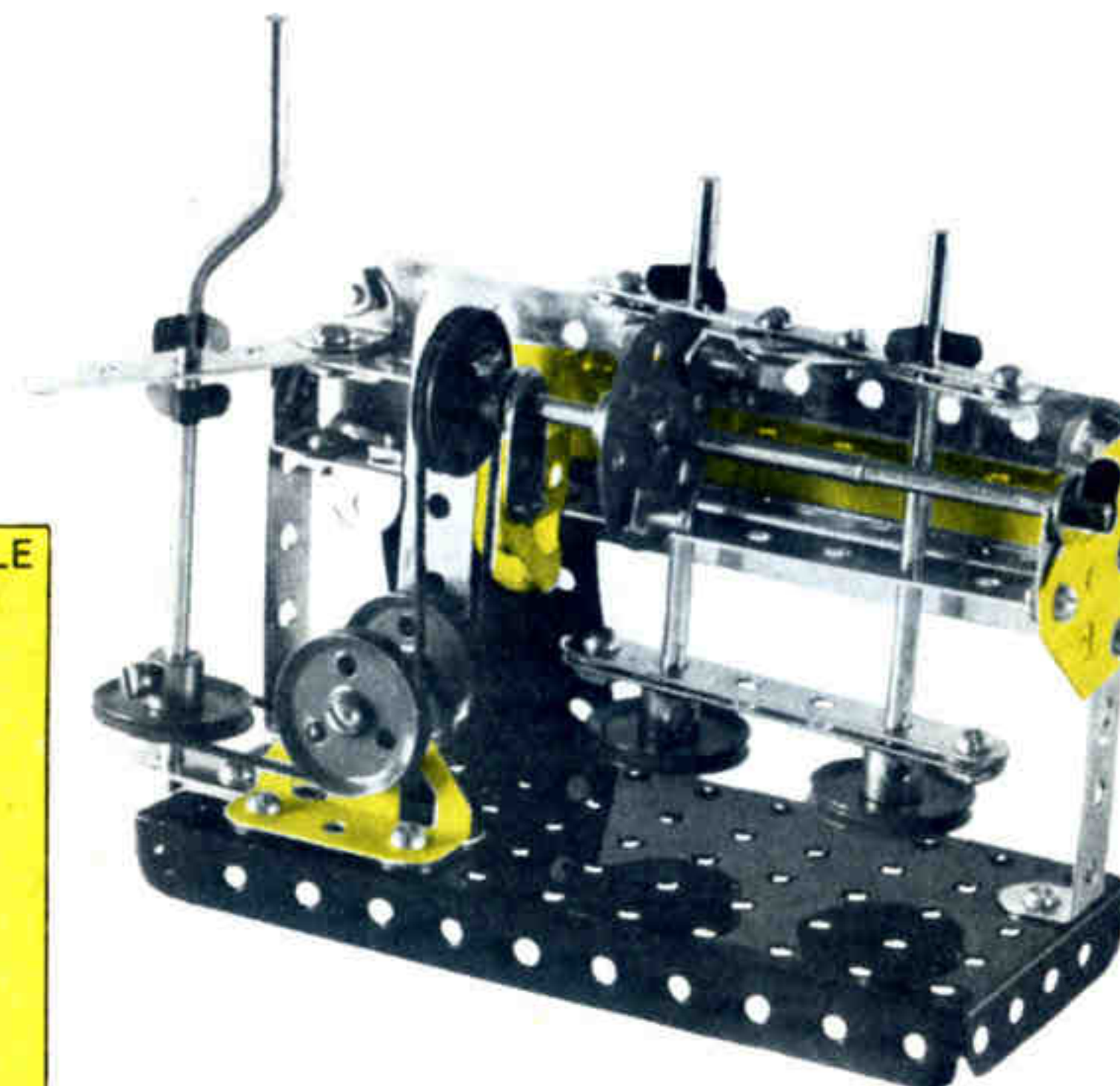

131

Articulated truck  
Camion avec  
plateforme articulée  
Camion snodato  
Sattelschfepper  
Camiao articulado

#### EMBOLO MAQUINA DE VAPOR /129

2 - 2  
4 - 5  
1 - 11  
8 - 12  
1 - 16  
1 - 17  
1 - 19s  
4 - 22  
1 - 24  
2 - 35  
39 - 37a  
39 - 37b  
3 - 38  
2 - 48a  
1 - 52  
2 - 111c  
1 - 125  
1 - 126  
1 - 126a  
1 - 155  
2 - 189  
1 - 194  
1 - 213  
4 - 235a

129

Piston for steam  
machine  
Piston de machine à  
vapeur  
Stantuffo macchina a  
vapore  
Dampfmaschinenkolben

Embolo máquina de  
vapor

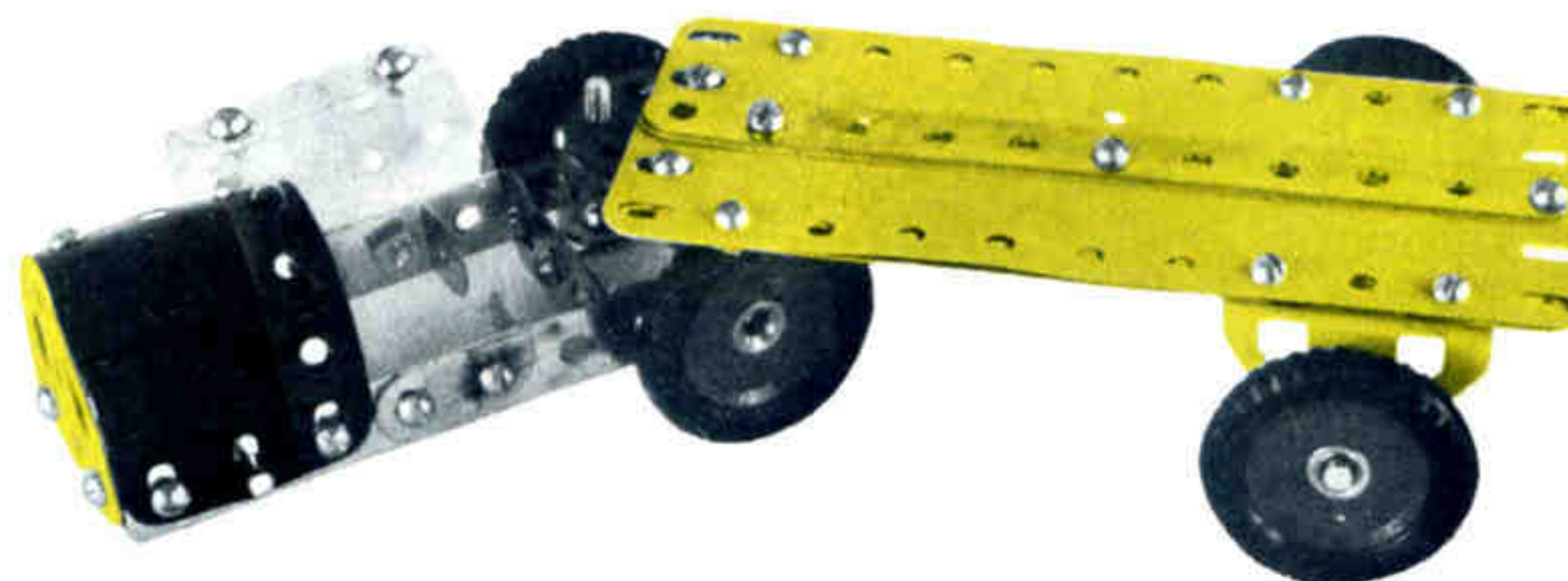

#### CAMION ARTICULADO 2/131

|         |          |
|---------|----------|
| 3 - 2   | 31 - 37b |
| 2 - 5   | 32 - 37a |
| 2 - 10  | 2 - 48a  |
| 1 - 11  | 1 - 111c |
| 3 - 12  | 1 - 126a |
| 1 - 16  | 3 - 126  |
| 2 - 17  | 4 - 142c |
| 4 - 22  | 1 - 155  |
| 1 - 22a | 2 - 189  |
| 1 - 24  | 2 - 193  |
| 4 - 35  | 2 - 194  |

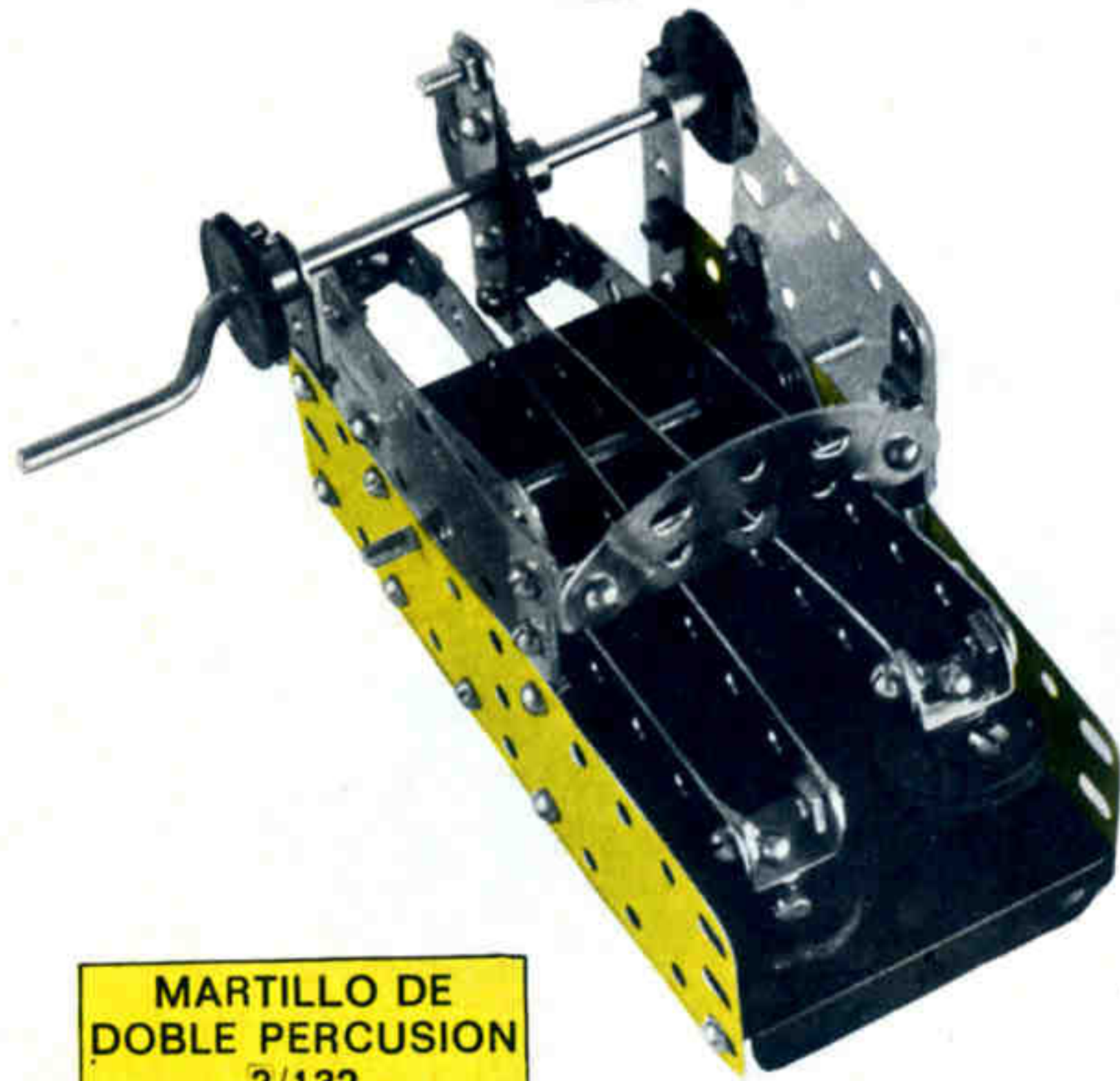

**MARTILLO DE DOBLE PERCUSION**

2/132

- 4 - 2
- 3 - 5
- 2 - 10
- 1 - 11
- 6 - 12
- 1 - 16
- 1 - 19s
- 4 - 22
- 1 - 24
- 4 - 35
- 39 - 37a
- 40 - 37b
- 6 - 38
- 1 - 48a
- 1 - 52
- 1 - 90a
- 4 - 111c
- 2 - 126a
- 2 - 189
- 2 - 193
- 2 - 235a

132

Double percussion hammer  
 Marteau pilon à double percussion  
 Martello di doppia percussione  
 Doppelschlaghammer  
 Martelo de doble percussao

**CENTRIFUGA GRAN VELOCIDAD**

2/133

- 3 - 2
- 2 - 5
- 1 - 11
- 8 - 12
- 1 - 16
- 1 - 19s
- 1 - 22
- 2 - 22a
- 4 - 35
- 40 - 37a
- 40 - 37b
- 7 - 38
- 2 - 48a
- 2 - 90a
- 3 - 111c
- 2 - 126
- 2 - 126a
- 2 - 189
- 4 - 235a

133

High speed centrifuge  
 Centrifugeuse rapide  
 Centrifugo grande velocità  
 Schnellkeitszentrifuge

Centrifuga grande velocidade

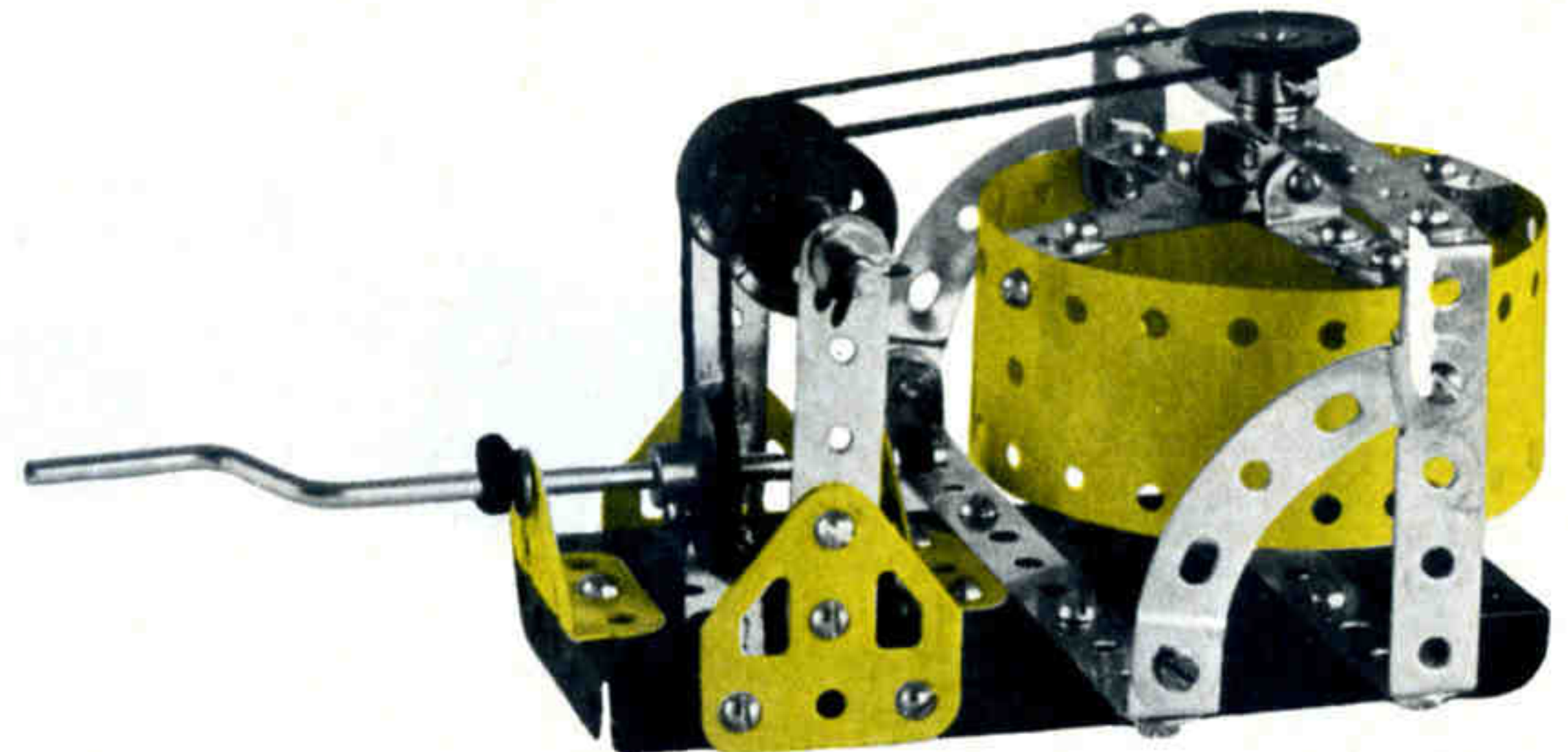



| CESTA DE BALONCESTO<br>3/136 |          |
|------------------------------|----------|
| 4 - 2                        | 1 - 48a  |
| 4 - 5                        | 1 - 52   |
| 1 - 11                       | 2 - 126  |
| 1 - 18b                      | 2 - 142c |
| 2 - 22                       | 2 - 190  |
| 28 - 37a                     | 4 - 235a |
| 30 - 37b                     |          |

136  
Basket for basket-ball game  
Panneau pour Basket ball  
Castello di pallacanestro  
Korbballnetz  
Cesto de basquetebol

| TRINEO 3/134 |          |
|--------------|----------|
| 2 - 2        | 4 - 37b  |
| 6 - 5        | 1 - 38   |
| 4 - 10       | 1 - 48a  |
| 1 - 11       | 2 - 90a  |
| 8 - 12       | 1 - 111c |
| 1 - 22       | 1 - 155  |
| 2 - 34       | 1 - 188  |
| 1 - 36       | 1 - 191  |
| 24 - 37a     | 1 - 199  |

134  
Sledge  
Traineau  
Slitta  
Schlitten  
Trenó



| PLANCHA 3/135 |  |
|---------------|--|
| 1 - 2         |  |
| 2 - 12        |  |
| 16 - 37a      |  |
| 16 - 37b      |  |
| 1 - 126a      |  |
| 1 - 188       |  |
| 2 - 189       |  |
| 1 - 190       |  |

135  
Iron  
Fer à repasser  
Ferro da stiro  
Buegekeisen  
Ferro de engomar



| CAMION 3/137 |          |
|--------------|----------|
| 3 - 2        | 2 - 90a  |
| 1 - 5        | 2 - 126  |
| 2 - 16       | 4 - 142c |
| 4 - 22       | 1 - 189  |
| 23 - 37a     | 1 - 190  |
| 23 - 37b     | 1 - 193  |
| 6 - 38       | 2 - 194  |
| 1 - 48a      | 1 - 199  |
| 1 - 52       |          |

137  
Lorry  
Camion  
Camion  
Lastwagen  
Camião

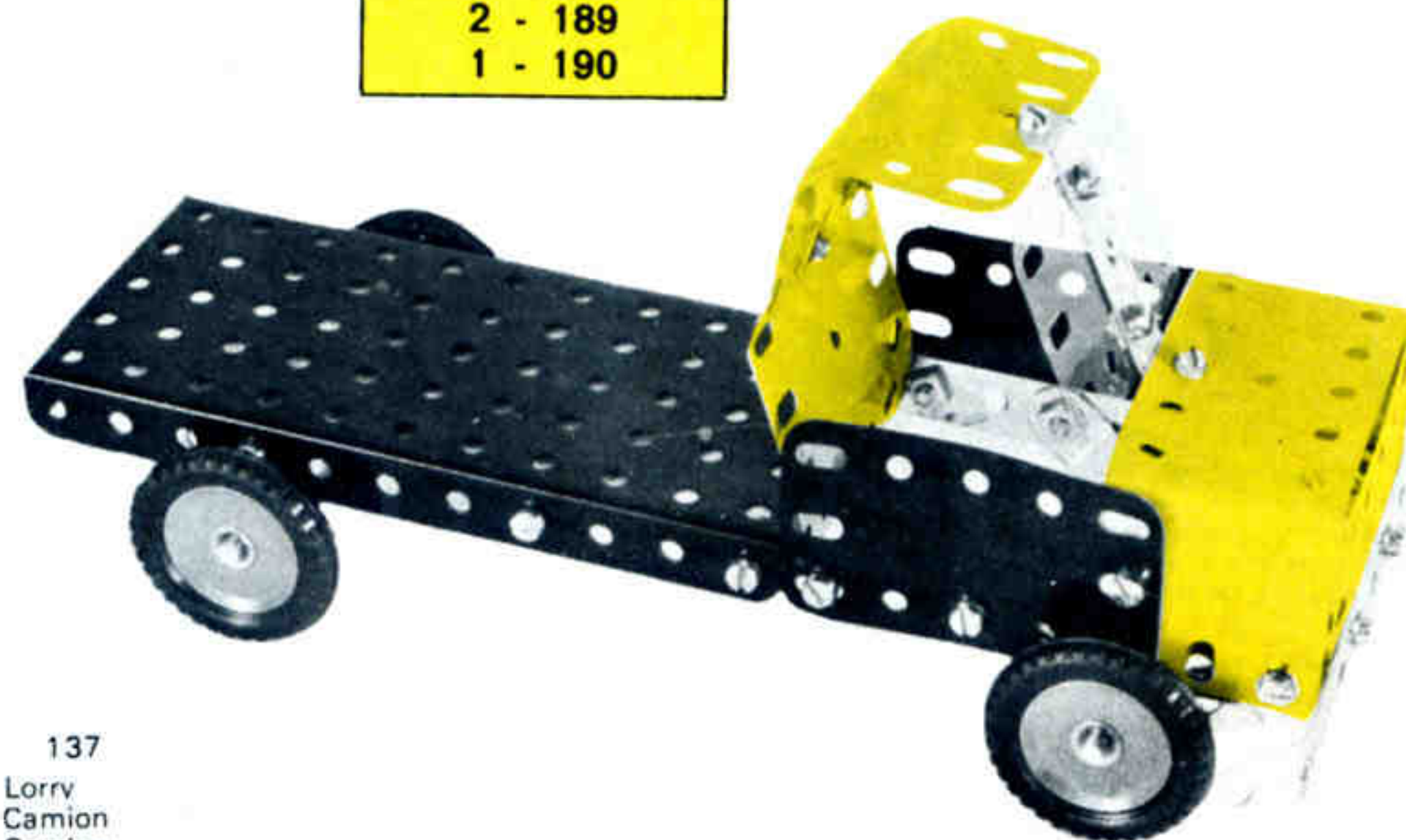

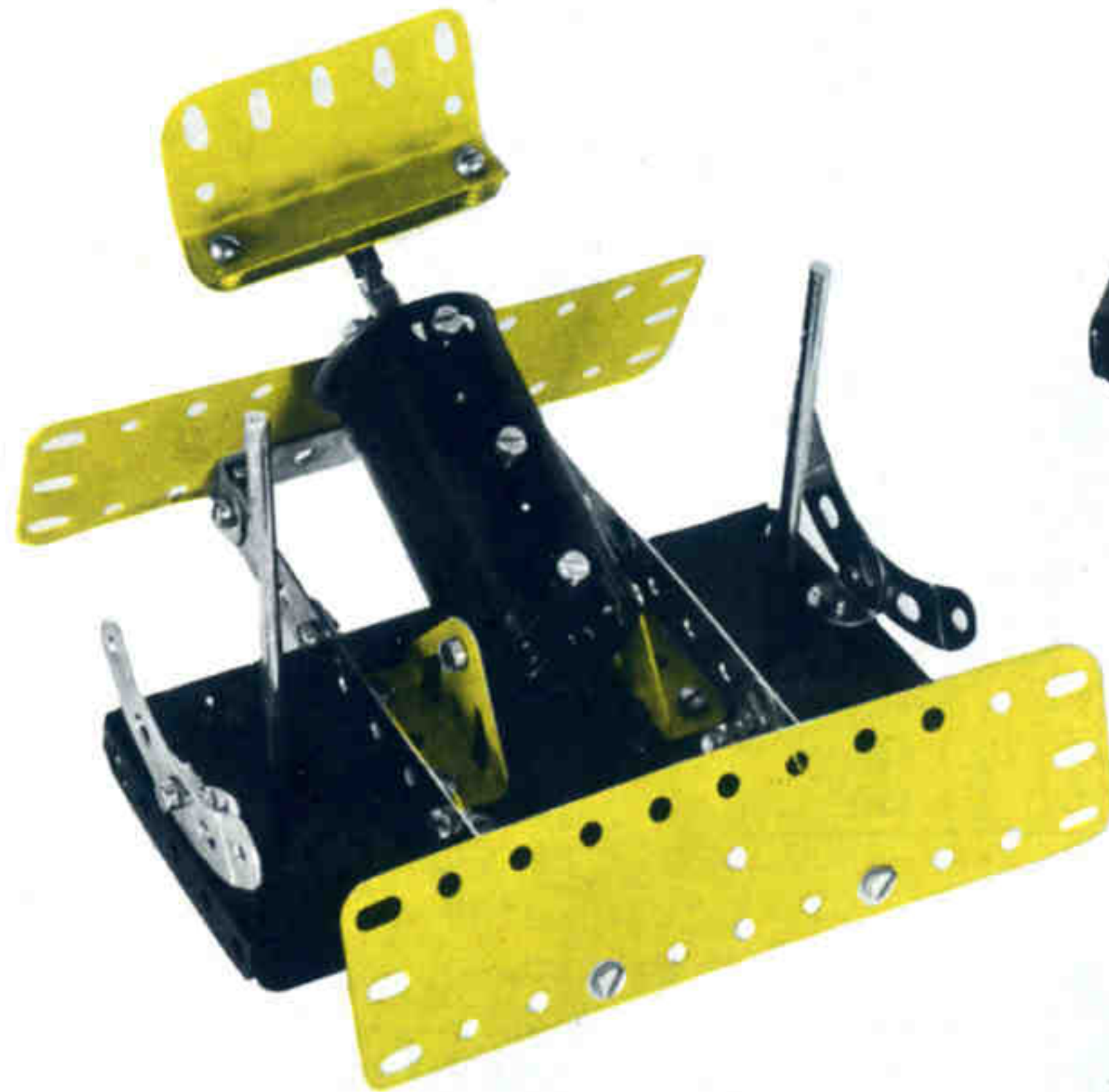

139

Moon seismograph  
Sismographe lunaire  
Sismografo lunare  
Mondeseismograph  
Sismógrafo lunar

| SISMOGRAFO LUNAR 3/139 |          |
|------------------------|----------|
| 2 - 2                  | 2 - 48a  |
| 1 - 5                  | 1 - 52   |
| 6 - 12                 | 2 - 90a  |
| 2 - 16                 | 2 - 111c |
| 1 - 18a                | 2 - 126  |
| 1 - 24                 | 2 - 189  |
| 2 - 35                 | 8 - 199  |
| 34 - 37b               | 2 - 200  |
| 36 - 37a               | 2 - 212  |
| 4 - 38                 |          |

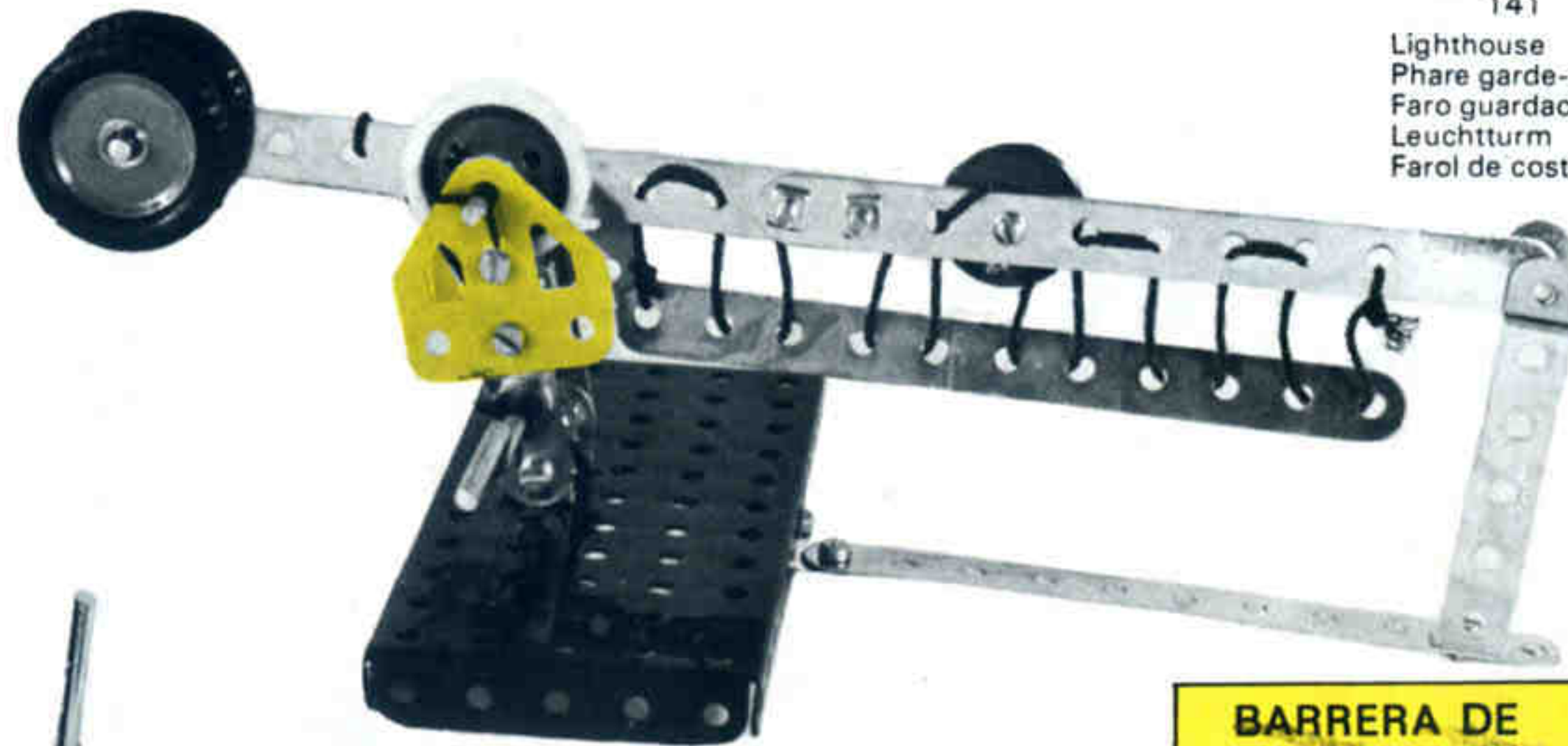

141

Lighthouse  
Phare garde-côtes  
Faro guardacoste  
Leuchtturm  
Farol de costa

| FARO GUARDACOSTAS 3/141 |          |
|-------------------------|----------|
| 4 - 2                   | 38 - 37b |
| 8 - 12                  | 2 - 48a  |
| 1 - 16                  | 1 - 52   |
| 2 - 17                  | 2 - 126  |
| 1 - 20a                 | 2 - 188  |
| 1 - 22                  | 2 - 189  |
| 5 - 35                  | 1 - 190  |
| 36 - 37a                |          |

| MUEBLE BAR 3/140 |          |
|------------------|----------|
| 2 - 2            | 2 - 126  |
| 4 - 5            | 2 - 188  |
| 3 - 12           | 2 - 189  |
| 32 - 37a         | 2 - 190  |
| 32 - 37b         | 1 - 191  |
| 2 - 48a          | 1 - 193  |
| 1 - 52           | 2 - 194a |
| 2 - 90a          |          |

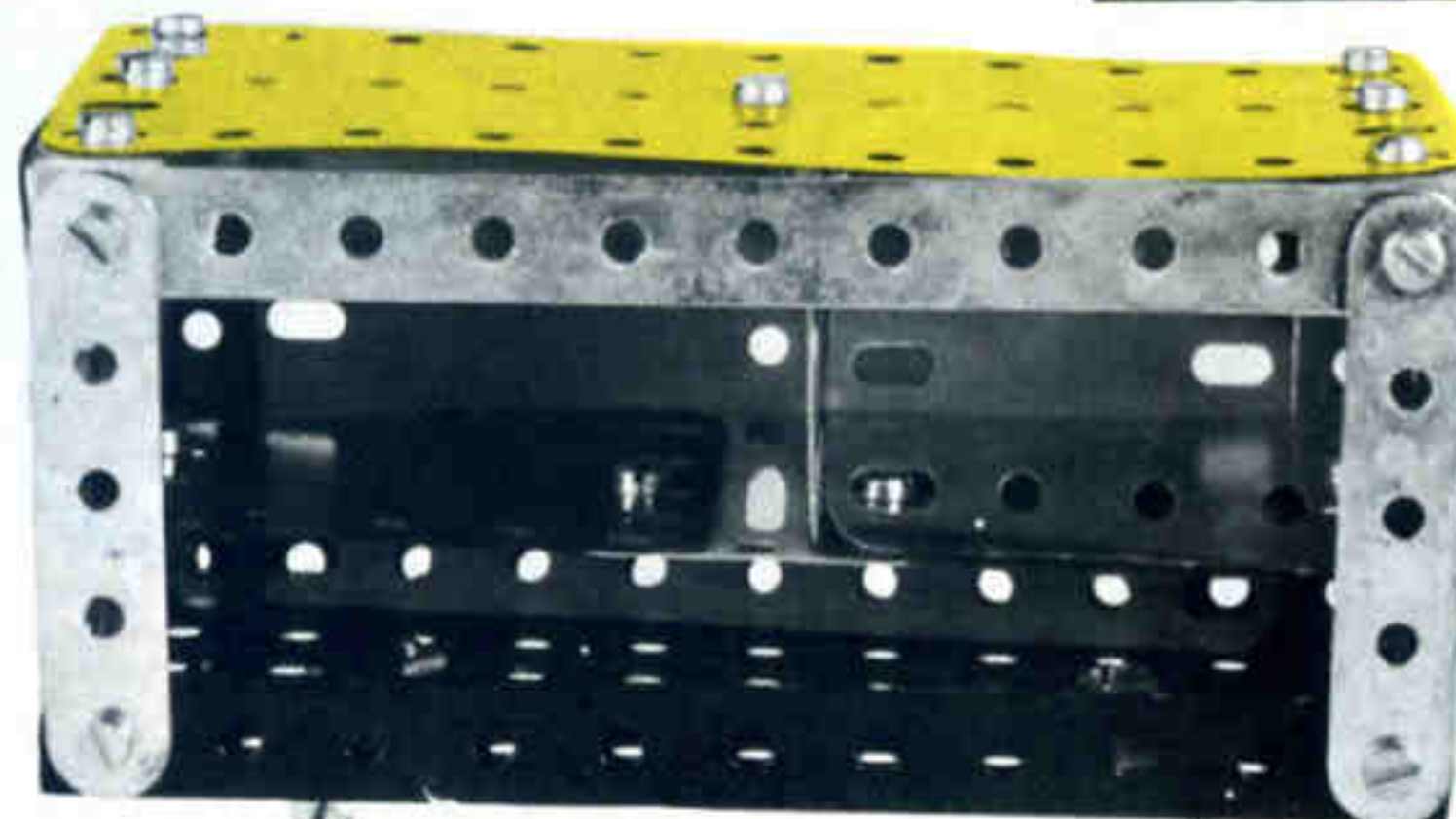

140

Bar fitted in a piece of furniture  
Meuble-bar  
Mobile bar  
Hausbar  
Móvel bar

| BARRERA DE PASO NIVEL 3/138 |          |
|-----------------------------|----------|
| 4 - 2                       | 12 - 37a |
| 2 - 5                       | 15 - 37b |
| 1 - 11                      | 6 - 38   |
| 2 - 12                      | 1 - 48a  |
| 1 - 17                      | 1 - 52   |
| 1 - 18b                     | 1 - 111c |
| 1 - 19s                     | 2 - 126a |
| 3 - 22                      | 2 - 142c |
| 2 - 22a                     | 2 - 155  |
| 7 - 35                      |          |

138

Level barrier  
Barrière de passage à niveau  
Barriera di passaggio a livello  
Bahnschranke  
Cancela de passagem de nível

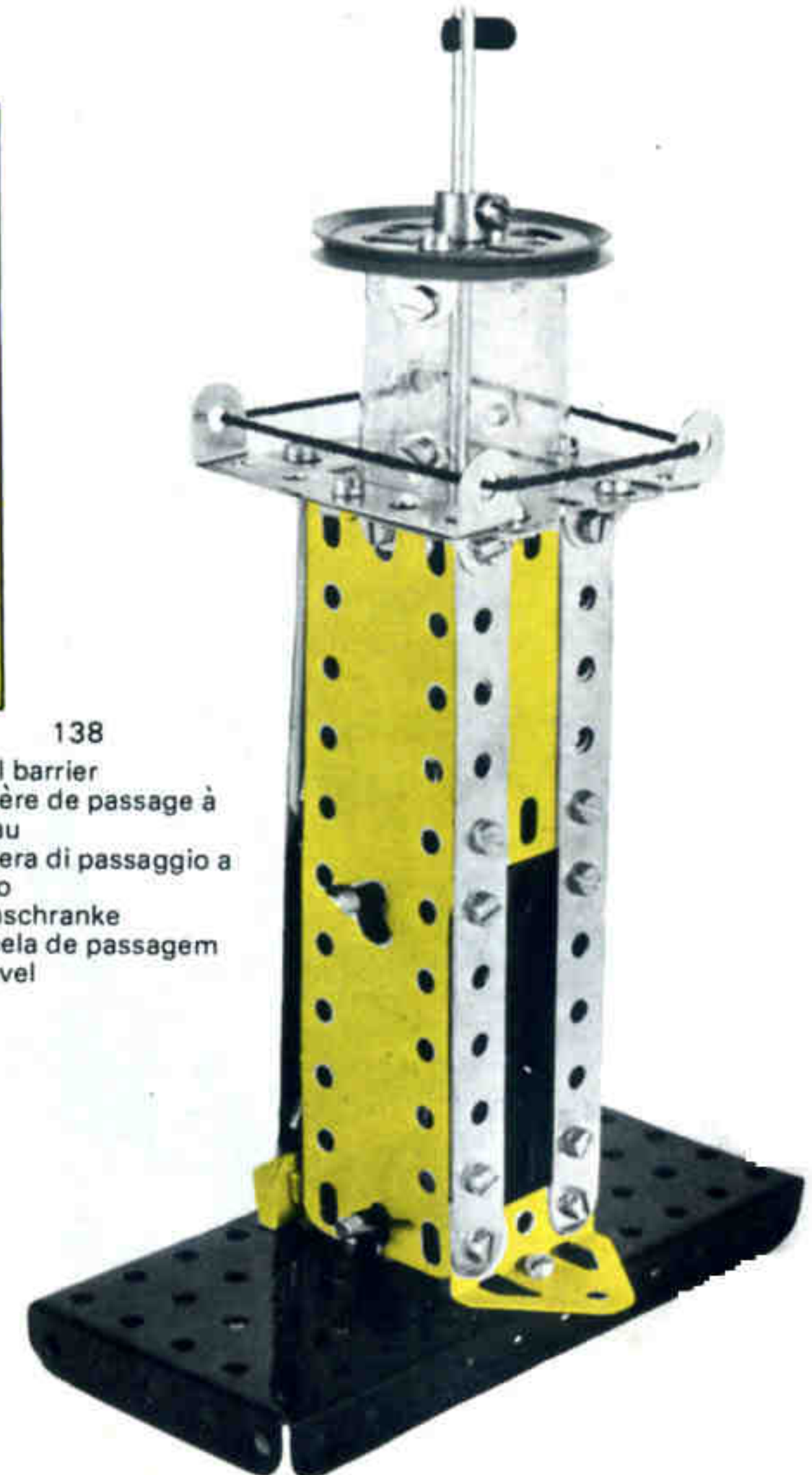

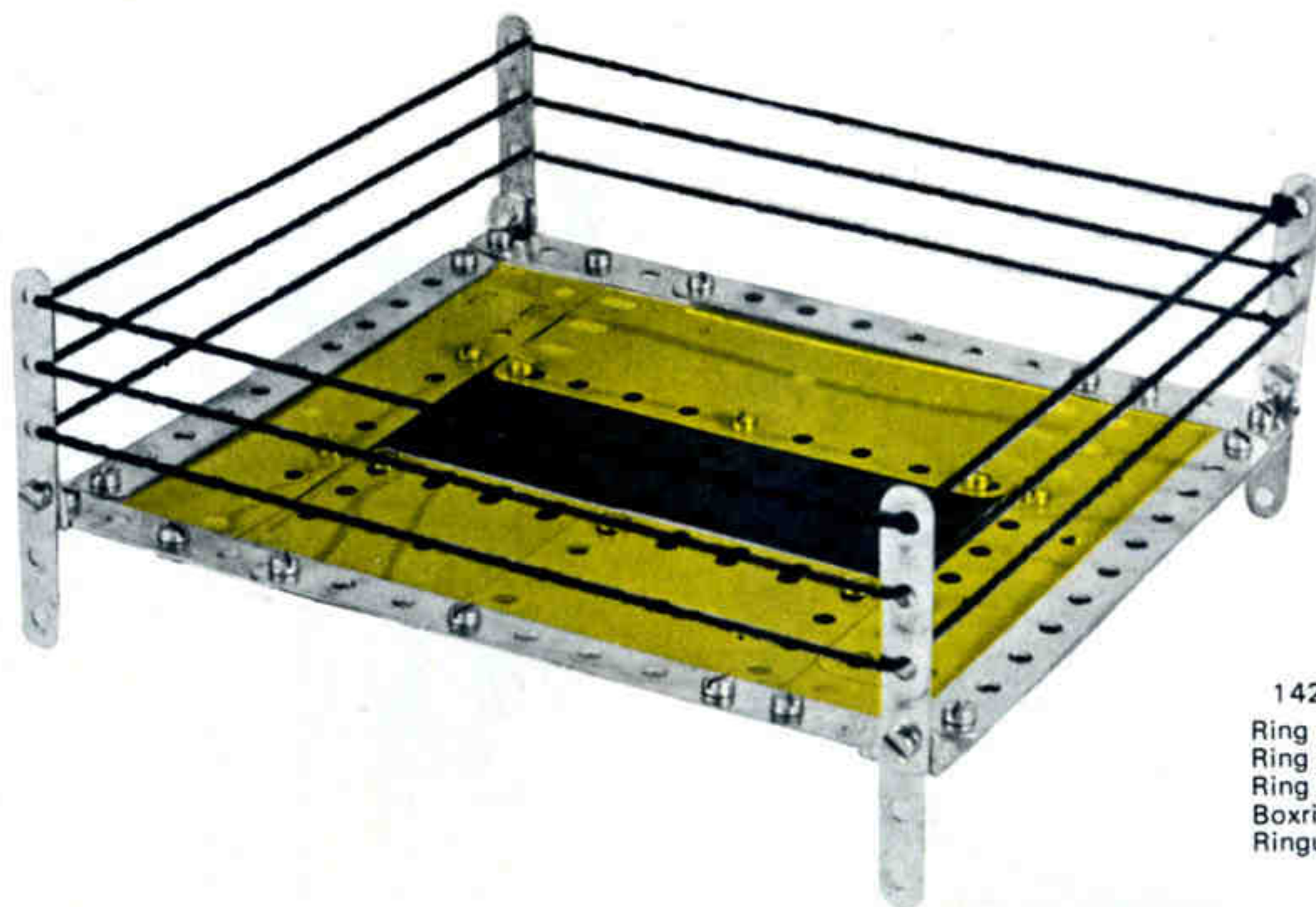

142  
Ring  
Ring  
Ring  
Boxring  
Ringue

| RING 3/142 |        |
|------------|--------|
| 4          | - 2    |
| 2          | - 5    |
| 4          | - 12   |
| 32         | - 37a  |
| 32         | - 37b  |
| 1          | - 52   |
| 1          | - 188  |
| 2          | - 189  |
| 2          | - 190  |
| 1          | - 191  |
| 4          | - 235a |

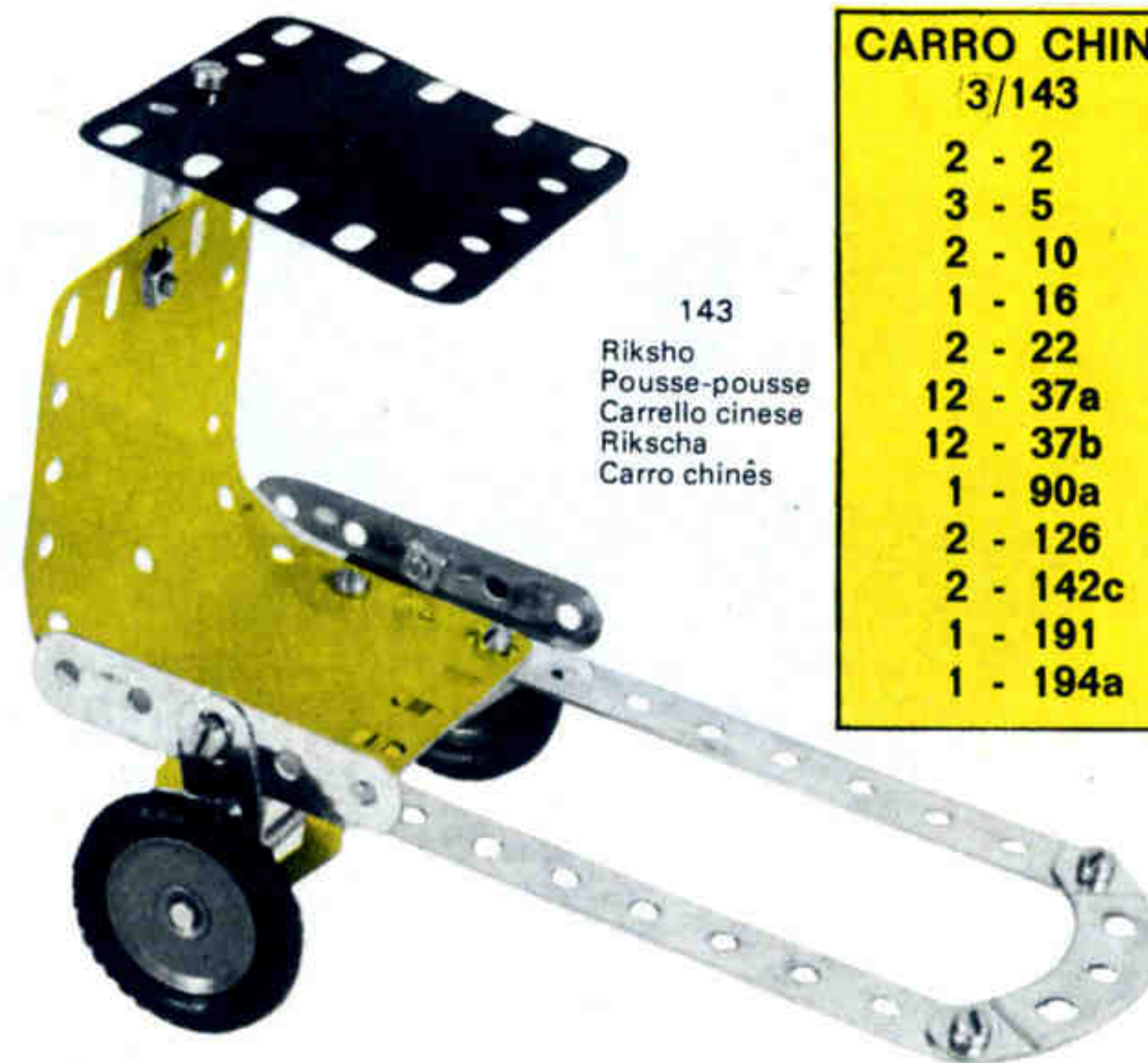

143  
Riksho  
Pousse-pousse  
Carrello cinese  
Riksha  
Carro chinès

| CARRO CHINO 3/143 |        |
|-------------------|--------|
| 2                 | - 2    |
| 3                 | - 5    |
| 2                 | - 10   |
| 1                 | - 16   |
| 2                 | - 22   |
| 12                | - 37a  |
| 12                | - 37b  |
| 1                 | - 90a  |
| 2                 | - 126  |
| 2                 | - 142c |
| 1                 | - 191  |
| 1                 | - 194a |

144  
Armored truck  
Fourgon blindé  
Furgone blindato  
Panzerwagen  
Furgao blindado

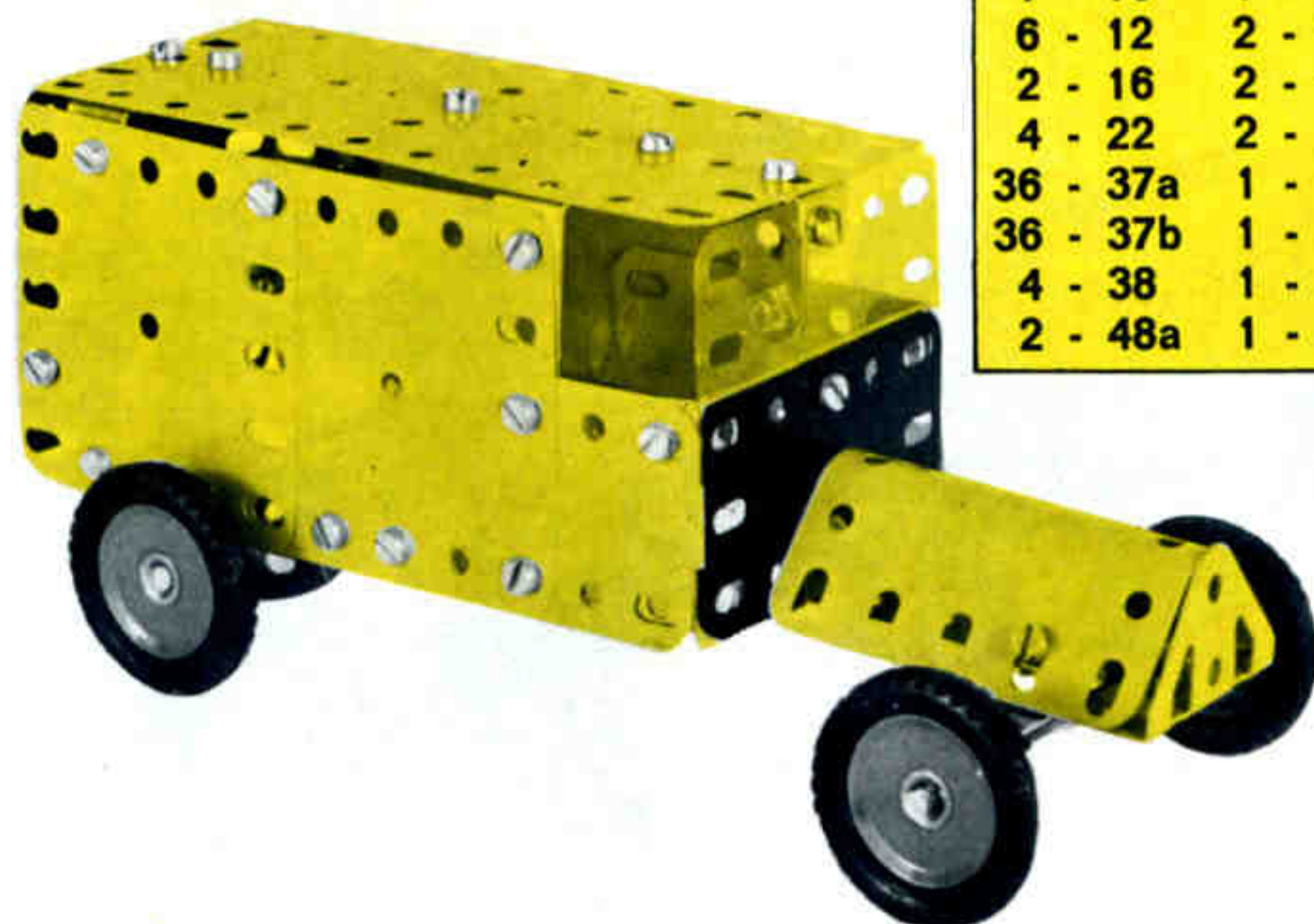

| FURGON BLINDADO 3/144 |       |   |        |
|-----------------------|-------|---|--------|
| 4                     | - 2   | 2 | - 90a  |
| 1                     | - 5   | 4 | - 142c |
| 1                     | - 10  | 1 | - 126  |
| 6                     | - 12  | 2 | - 188  |
| 2                     | - 16  | 2 | - 189  |
| 4                     | - 22  | 2 | - 190  |
| 36                    | - 37a | 1 | - 191  |
| 36                    | - 37b | 1 | - 193  |
| 4                     | - 38  | 1 | - 194  |
| 2                     | - 48a | 1 | - 199  |

| MESA PING-PONG 3/145 |       |
|----------------------|-------|
| 2                    | - 2   |
| 6                    | - 5   |
| 27                   | - 37a |
| 27                   | - 37b |
| 1                    | - 52  |
| 2                    | - 188 |
| 1                    | - 189 |
| 2                    | - 190 |
| 1                    | - 191 |

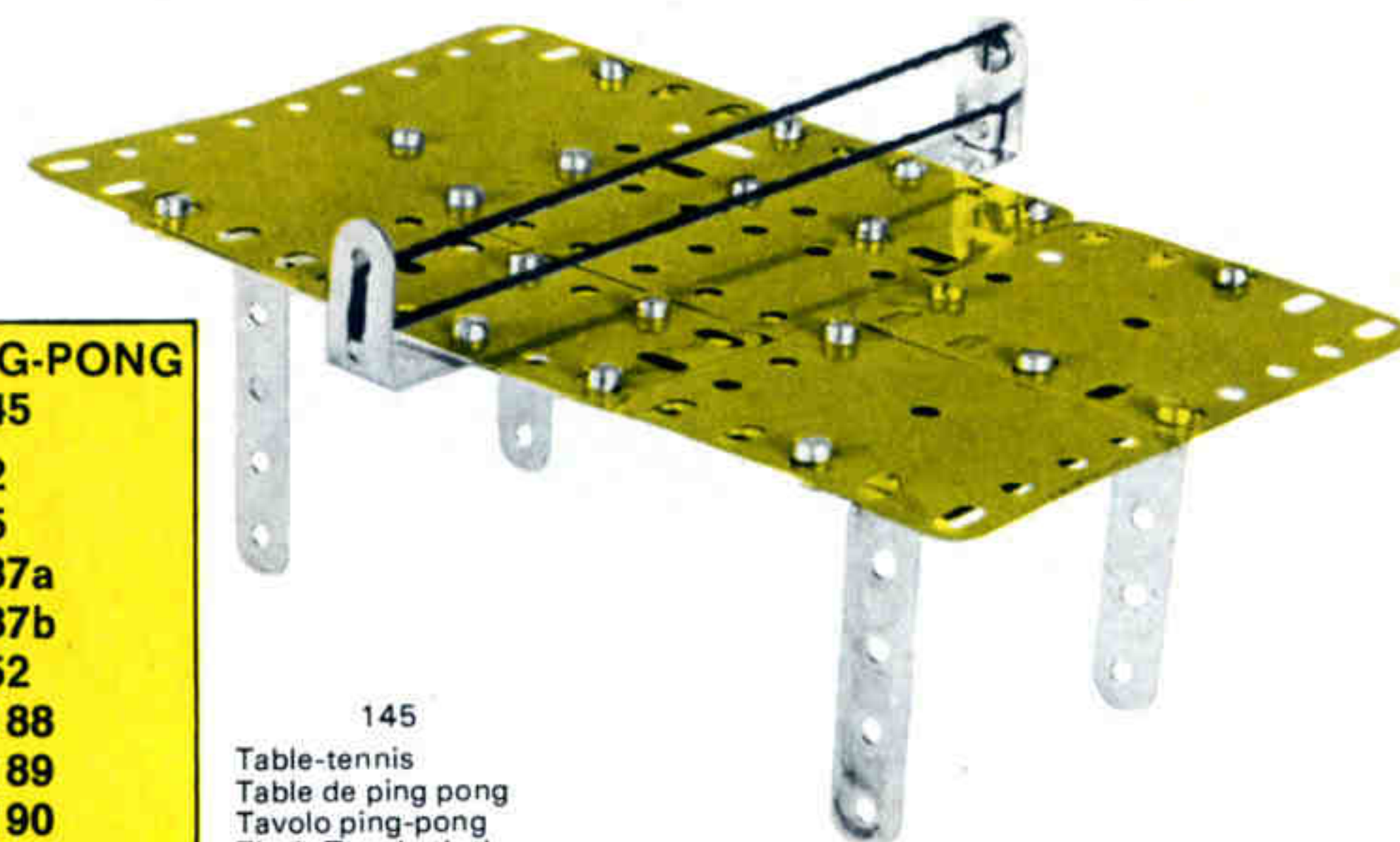

145  
Table-tennis  
Table de ping pong  
Tavolo ping-pong  
Tisch-Tennis-tisch  
Mesa pingue-pongue

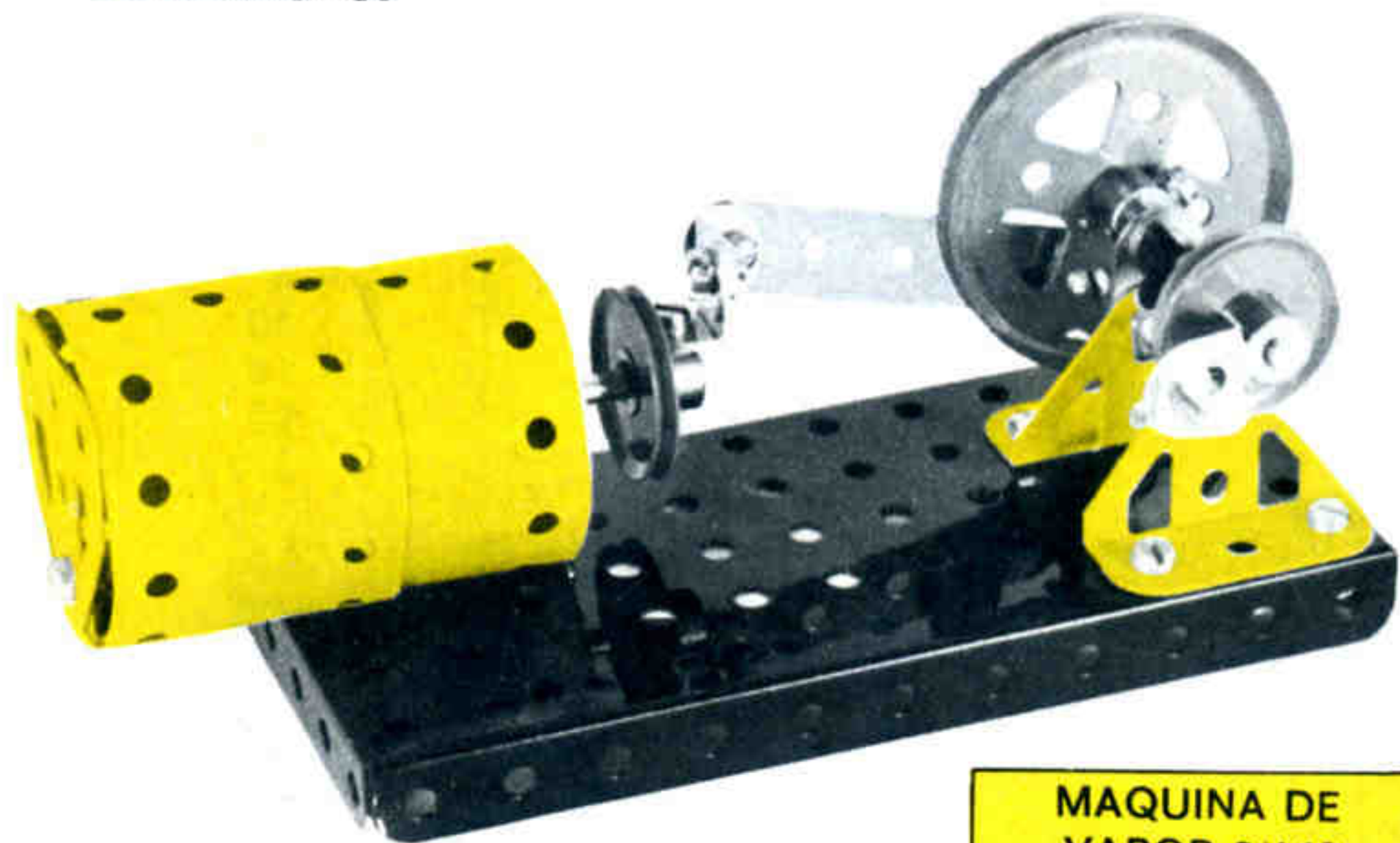

148  
Rocking chair  
Rocking chair  
Seggiolone  
Schaukelstuhl  
Cadeira de balanço

**MECEDORA**  
3/148

|          |
|----------|
| 2 - 2    |
| 6 - 5    |
| 2 - 12   |
| 12 - 37a |
| 12 - 37b |
| 2 - 48a  |
| 1 - 191  |

146  
Steam machine  
Machine à vapeur  
Macchina da vapore  
Dampfmaschine  
Máquina de vapor

**MAQUINA DE VAPOR 3/146**

|          |          |
|----------|----------|
| 1 - 5    | 8 - 37b  |
| 5 - 12   | 5 - 38   |
| 2 - 17   | 1 - 52   |
| 1 - 20a  | 3 - 111c |
| 2 - 22   | 2 - 126  |
| 1 - 24   | 1 - 126a |
| 2 - 35   | 2 - 189  |
| 16 - 37a |          |

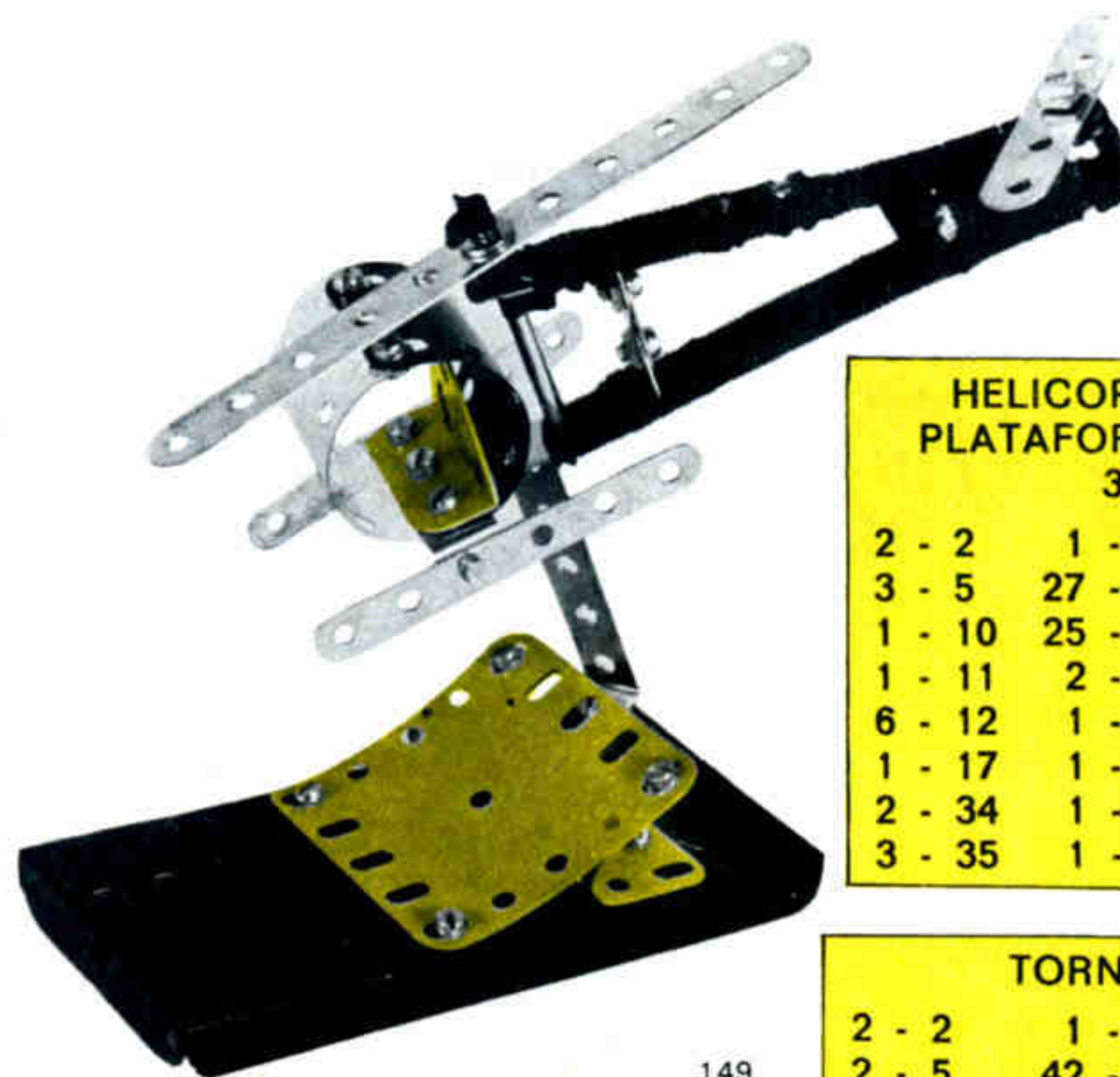

147  
Helicopter with platform  
Hélicoptère avec support  
Elicottero con piattaforma (supporto)  
Hubschrauber mit platform  
Helicóptero com plataforma (suporte)

**HELICOPTERO CON PLATAFORMA (Soporte) 3/147**

|        |          |          |
|--------|----------|----------|
| 2 - 2  | 1 - 36   | 1 - 126  |
| 3 - 5  | 27 - 37a | 1 - 190  |
| 1 - 10 | 25 - 37b | 1 - 193  |
| 1 - 11 | 2 - 38   | 1 - 194  |
| 6 - 12 | 1 - 48a  | 1 - 199  |
| 1 - 17 | 1 - 40   | 2 - 235a |
| 2 - 34 | 1 - 52   |          |
| 3 - 35 | 1 - 111c |          |

**TORNO 3/149**

|         |          |          |
|---------|----------|----------|
| 2 - 2   | 1 - 36   | 2 - 126  |
| 2 - 5   | 42 - 37a | 2 - 126a |
| 8 - 12  | 40 - 37b | 2 - 188  |
| 1 - 16  | 2 - 38   | 2 - 189  |
| 1 - 19s | 2 - 48a  | 2 - 194  |
| 1 - 20a | 1 - 52   | 2 - 194a |
| 2 - 34  | 2 - 90a  | 1 - 199  |
| 3 - 35  | 2 - 111c | 2 - 235a |

149  
Reel  
Treuil  
Tornio  
Derhbank  
Torno

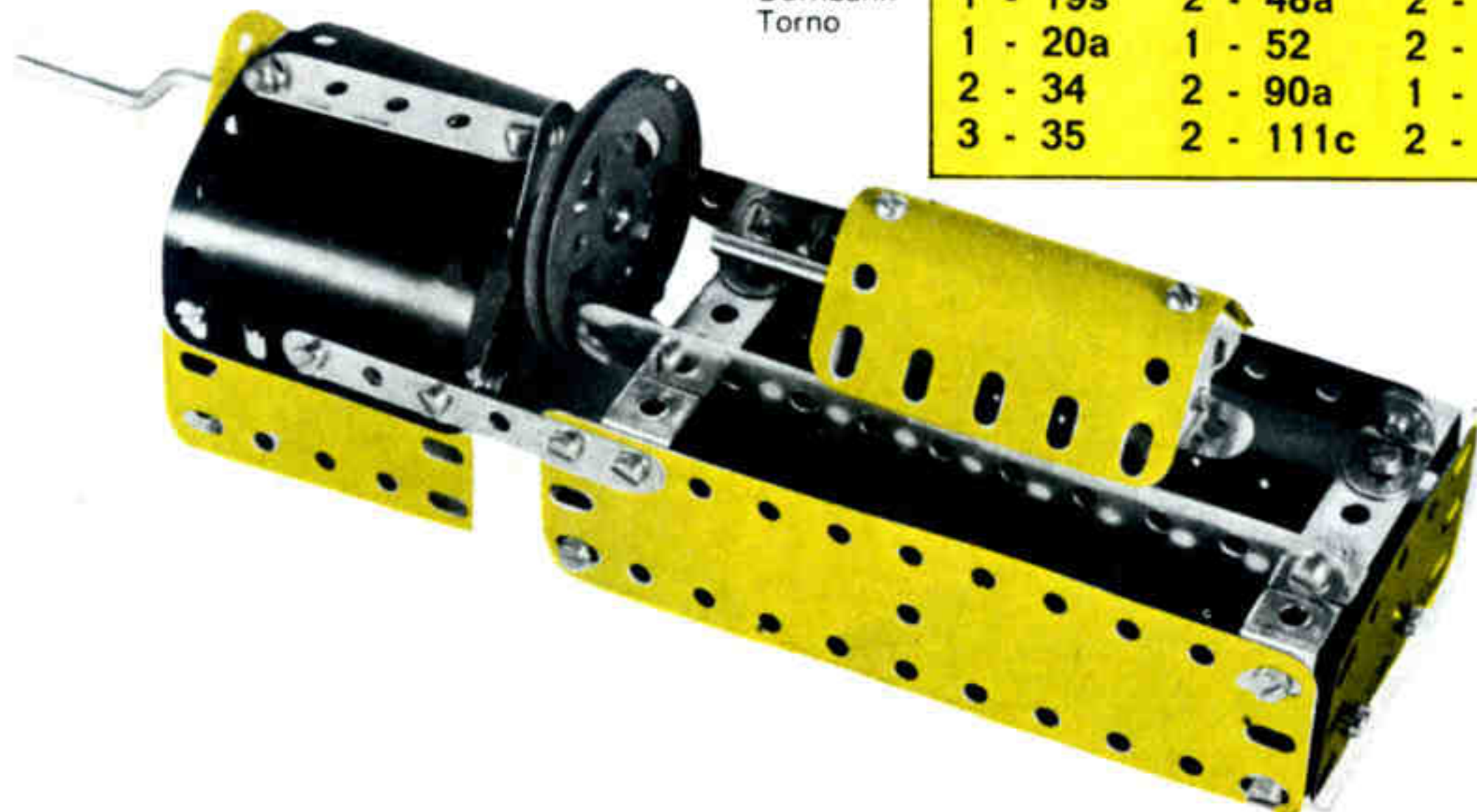



**MODULO LUNAR  
3/150**

|          |          |
|----------|----------|
| 6 - 5    | 2 - 90a  |
| 8 - 12   | 2 - 126a |
| 1 - 17   | 2 - 190  |
| 1 - 24   | 1 - 191  |
| 1 - 34   | 2 - 194a |
| 1 - 36   | 1 - 212  |
| 28 - 37a | 2 - 235a |
| 28 - 37b |          |

150  
Moon module  
Module lunaire  
Modulo lunare  
Mondmodul  
Módulo lunar



**COCHE DE CARRERAS 3/151**

|        |          |          |
|--------|----------|----------|
| 4 - 2  | 50 - 37a | 1 - 188  |
| 6 - 5  | 50 - 37b | 2 - 189  |
| 3 - 10 | 2 - 48a  | 2 - 190  |
| 1 - 11 | 1 - 52   | 1 - 191  |
| 8 - 12 | 1 - 111c | 2 - 193  |
| 2 - 16 | 1 - 125  | 1 - 212  |
| 1 - 17 | 2 - 126  | 1 - 213  |
| 4 - 22 | 4 - 142c | 4 - 235a |

151  
Racing car  
Voiture de course  
Vettura da corsa  
Rennwagen  
Carro de corridas

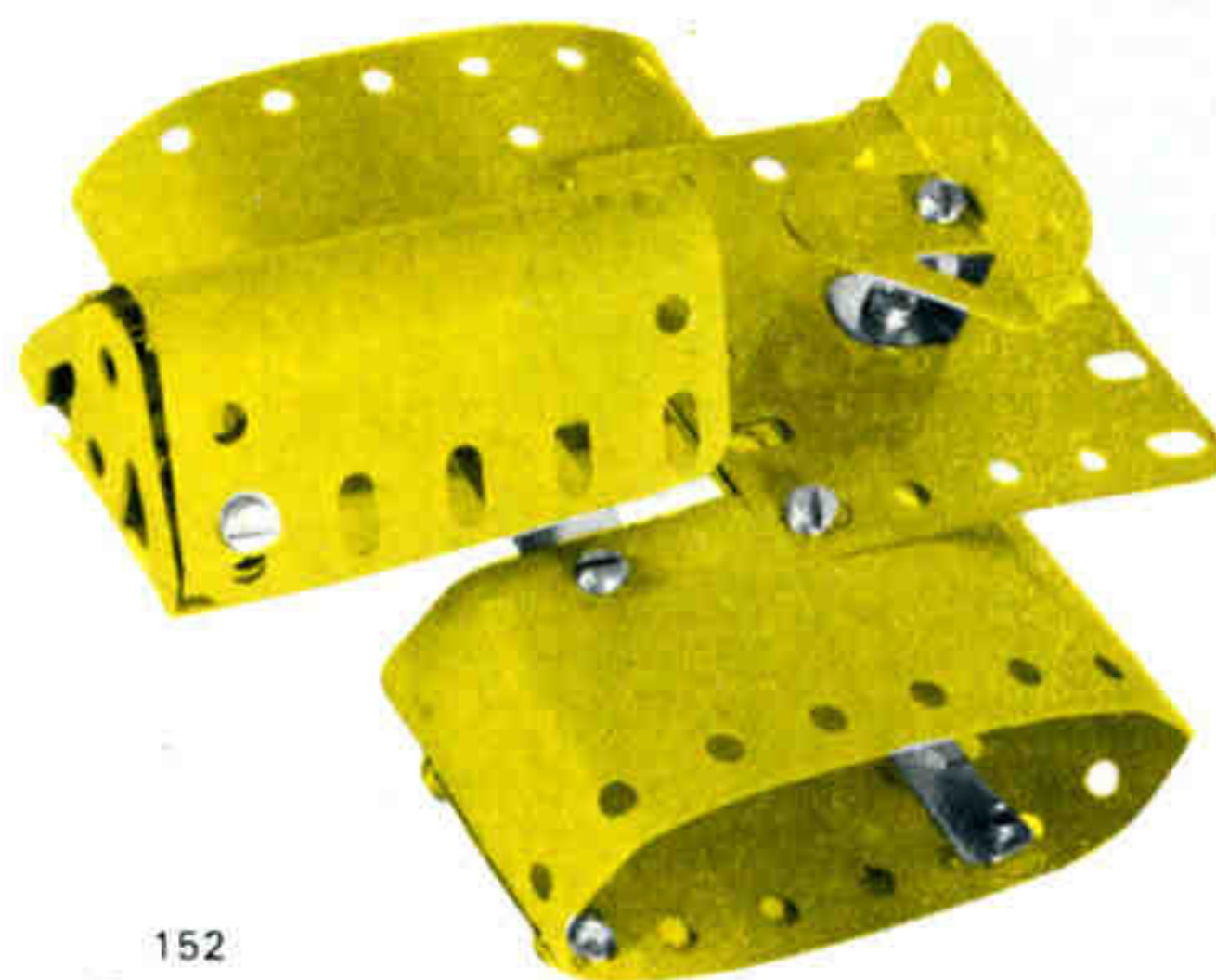

**CARRETA 3/154**

|          |          |
|----------|----------|
| 2 - 2    | 1 - 52   |
| 6 - 5    | 3 - 111c |
| 2 - 10   | 2 - 126  |
| 2 - 16   | 2 - 126a |
| 4 - 22   | 4 - 142c |
| 35 - 37a | 2 - 190  |
| 29 - 37b | 1 - 191  |
| 2 - 48a  | 1 - 194  |

154  
Cart  
Charrette  
Carretta  
Kutsche  
Carroça

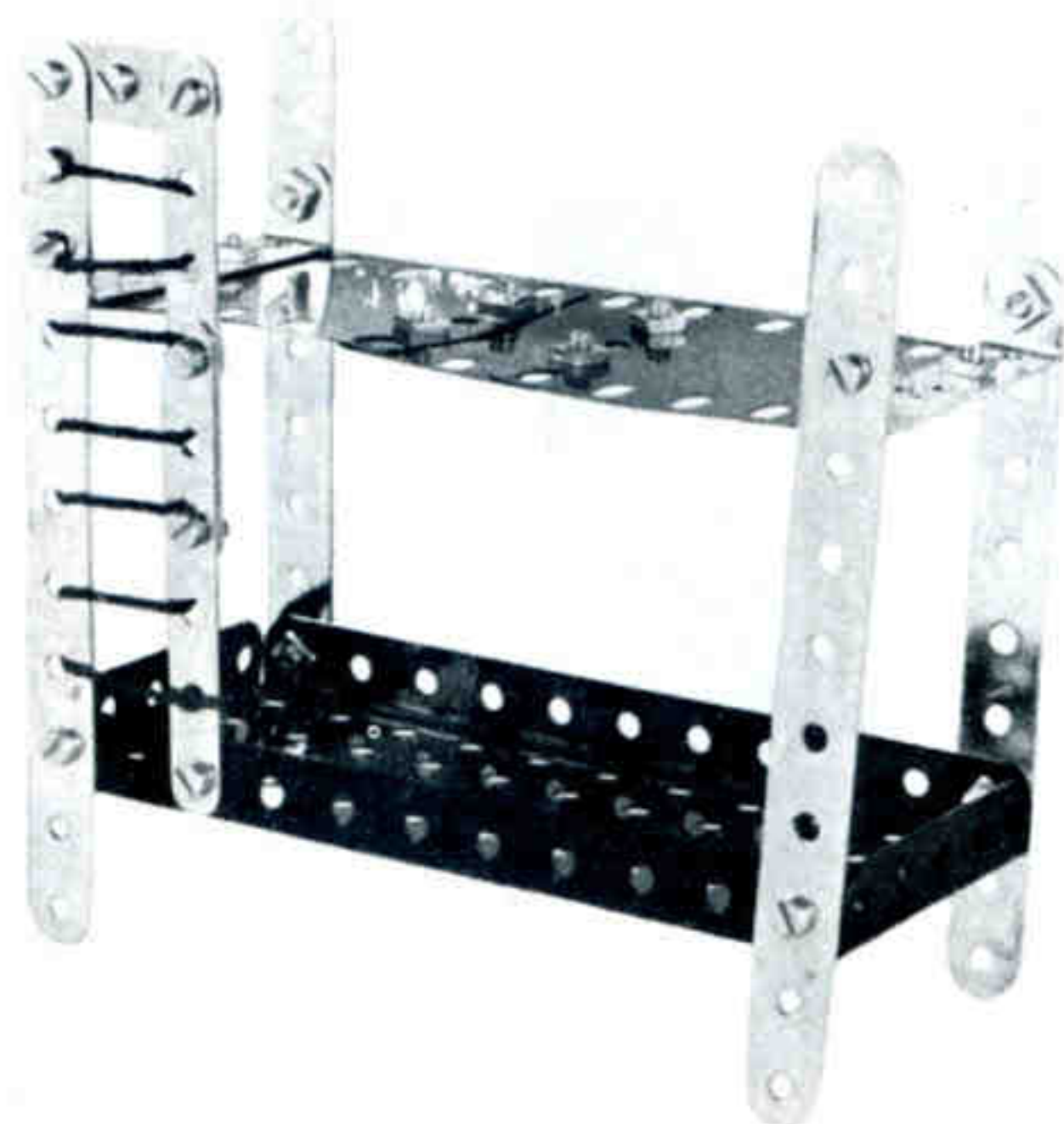

152  
Bunk-beds  
Couchette  
Lettiga  
Schlafkoje  
Beliche

**LITERA 3/152**

|          |
|----------|
| 4 - 2    |
| 2 - 10   |
| 21 - 37a |
| 21 - 37b |
| 2 - 48a  |
| 1 - 52   |
| 1 - 194  |
| 2 - 194a |

153  
Tractor  
Tracteur  
Trattore  
Traktor  
Tractor

**TRACTOR 3/153**

|          |
|----------|
| 2 - 5    |
| 1 - 11   |
| 2 - 12   |
| 21 - 37a |
| 21 - 37b |
| 2 - 126  |
| 1 - 235a |
| 2 - 188  |
| 2 - 189  |
| 1 - 190  |
| 1 - 199  |

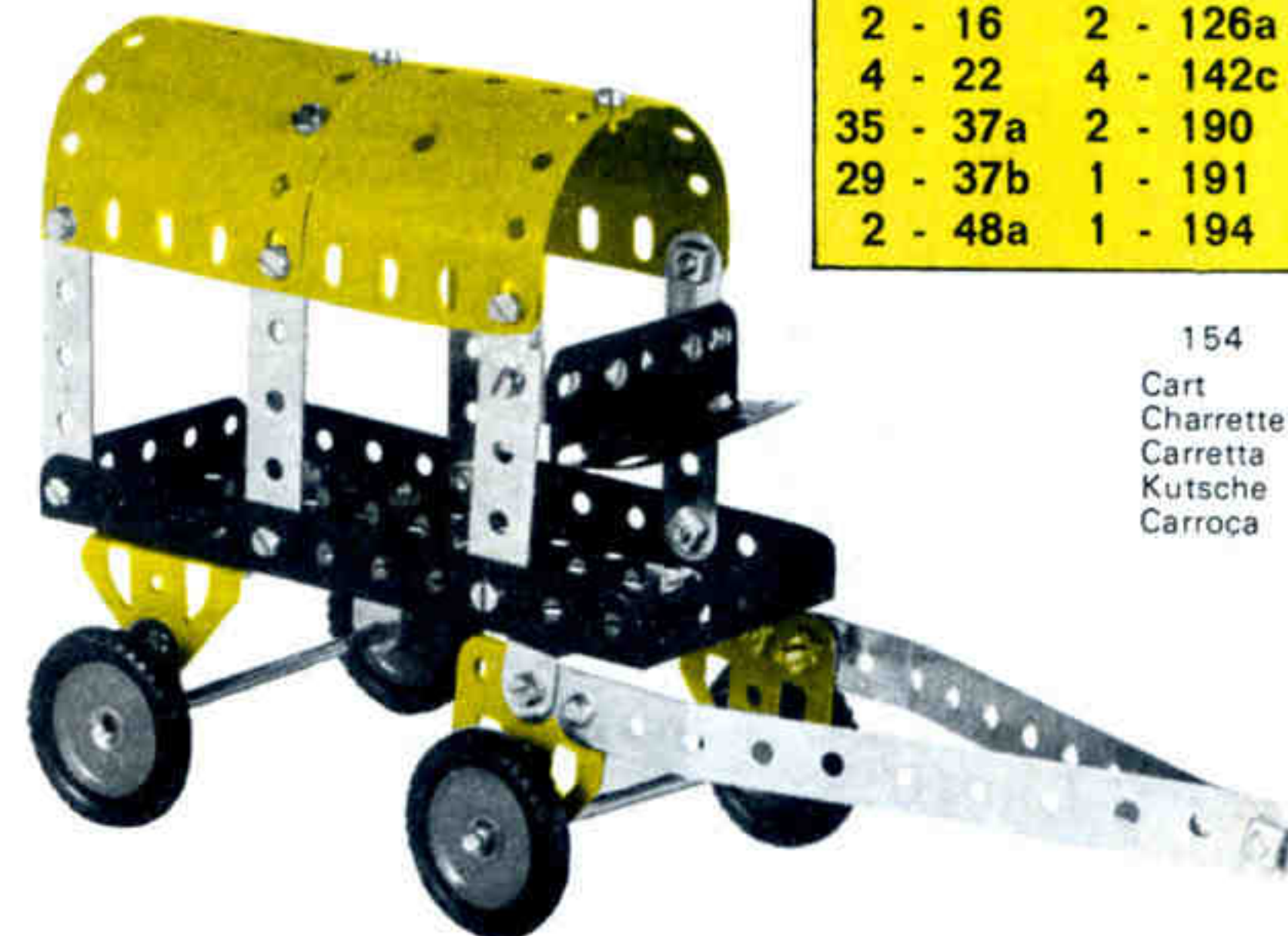

- MEZCLADORA**  
3/155
- 1 - 2
  - 3 - 5
  - 1 - 16
  - 1 - 17
  - 1 - 19s
  - 1 - 20a
  - 4 - 22
  - 2 - 22a
  - 1 - 24
  - 1 - 35

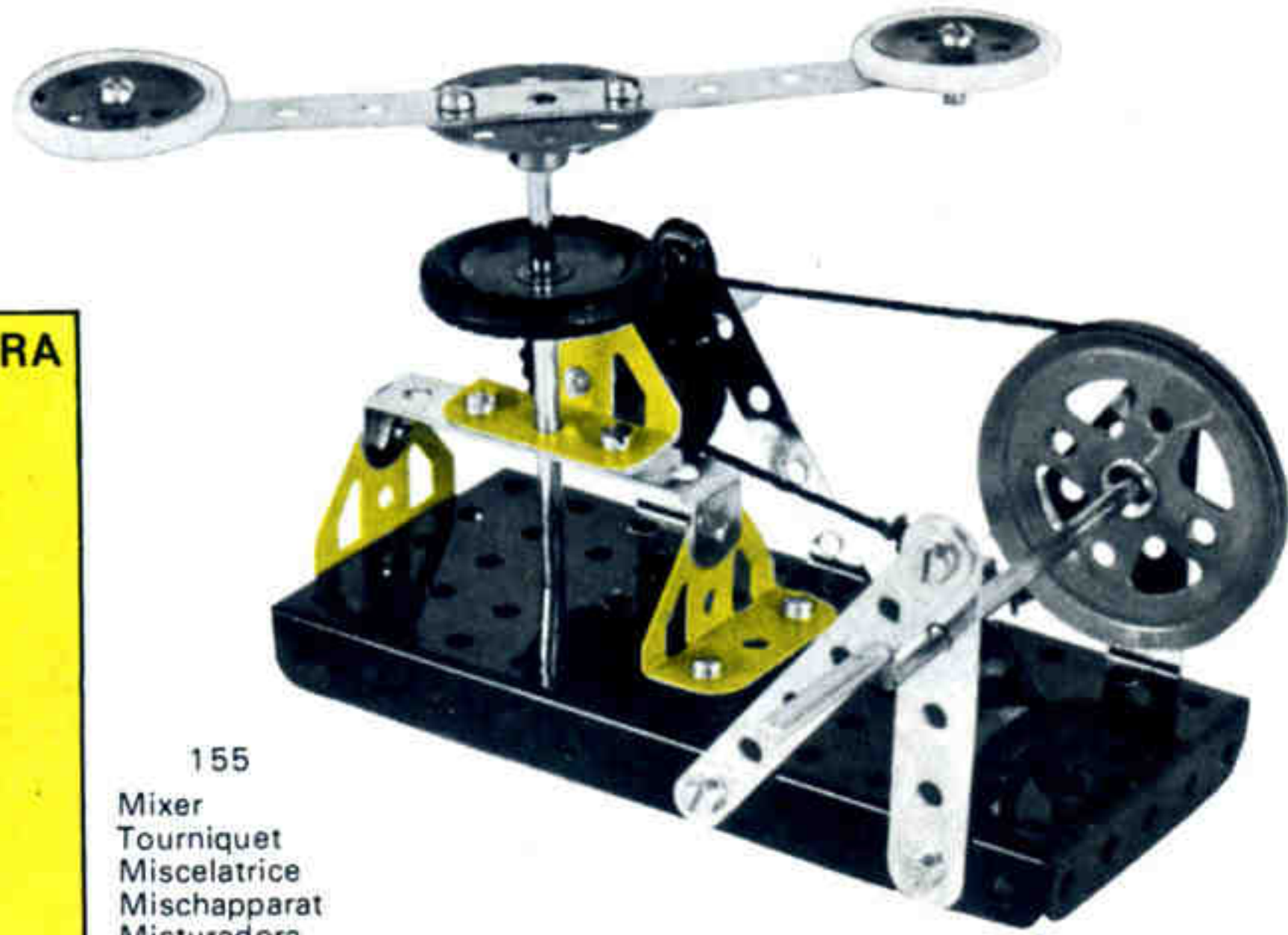

155  
Mixer  
Tourniquet  
Miscelatrice  
Mischapparat  
Misturadora

- GRUA GARAGE**  
3/157
- 4 - 2
  - 2 - 16
  - 4 - 22
  - 2 - 22a
  - 1 - 24
  - 6 - 35
  - 16 - 37a
  - 15 - 37b
  - 3 - 38
  - 2 - 48a
  - 1 - 52
  - 1 - 57c
  - 1 - 11
  - 1 - 18b
  - 1 - 111c
  - 2 - 126a
  - 4 - 235a

157  
Garage crane  
Crochet éleveur pour  
garage  
Gru Garage  
Stehkran  
Grua de garagem

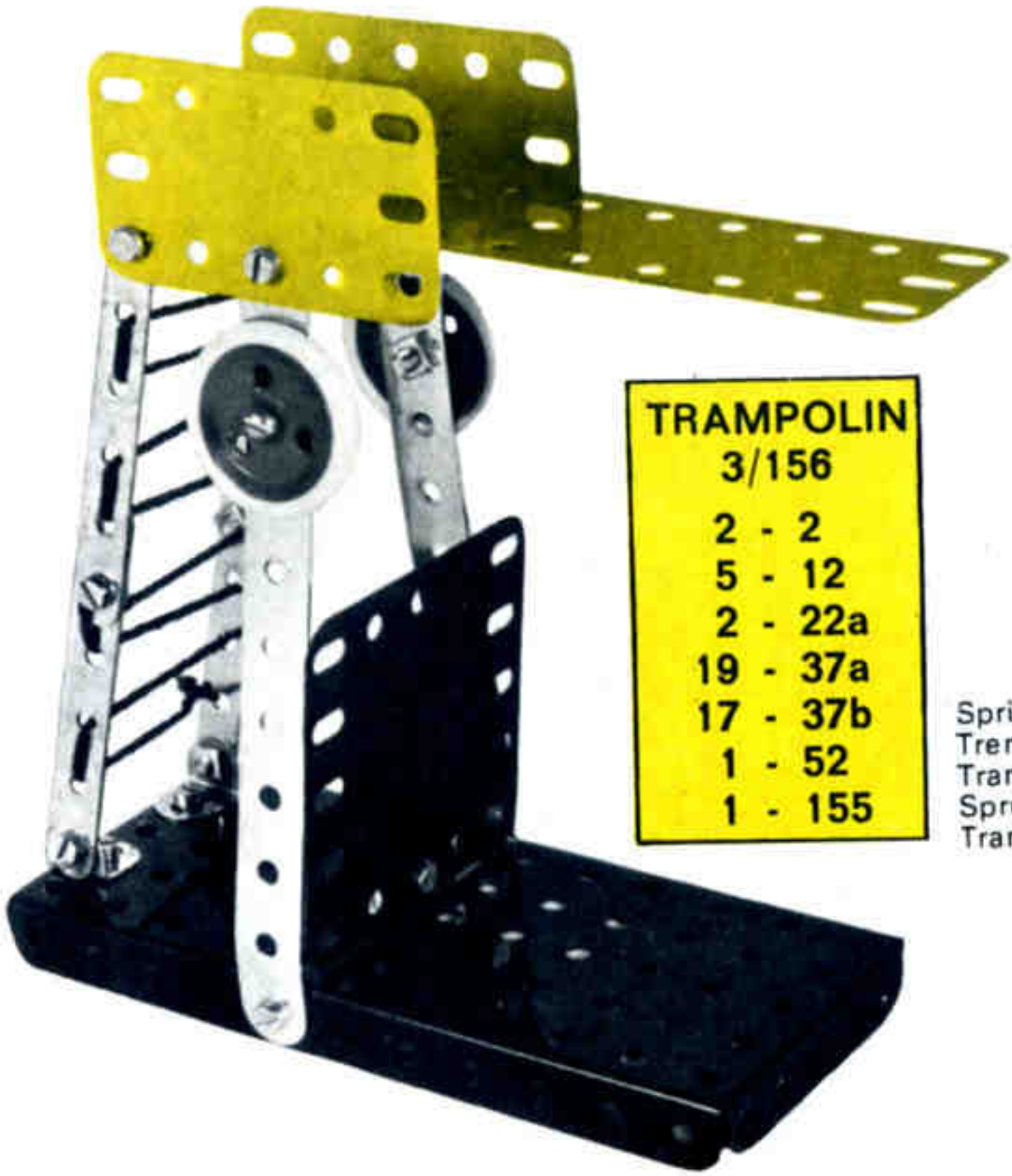
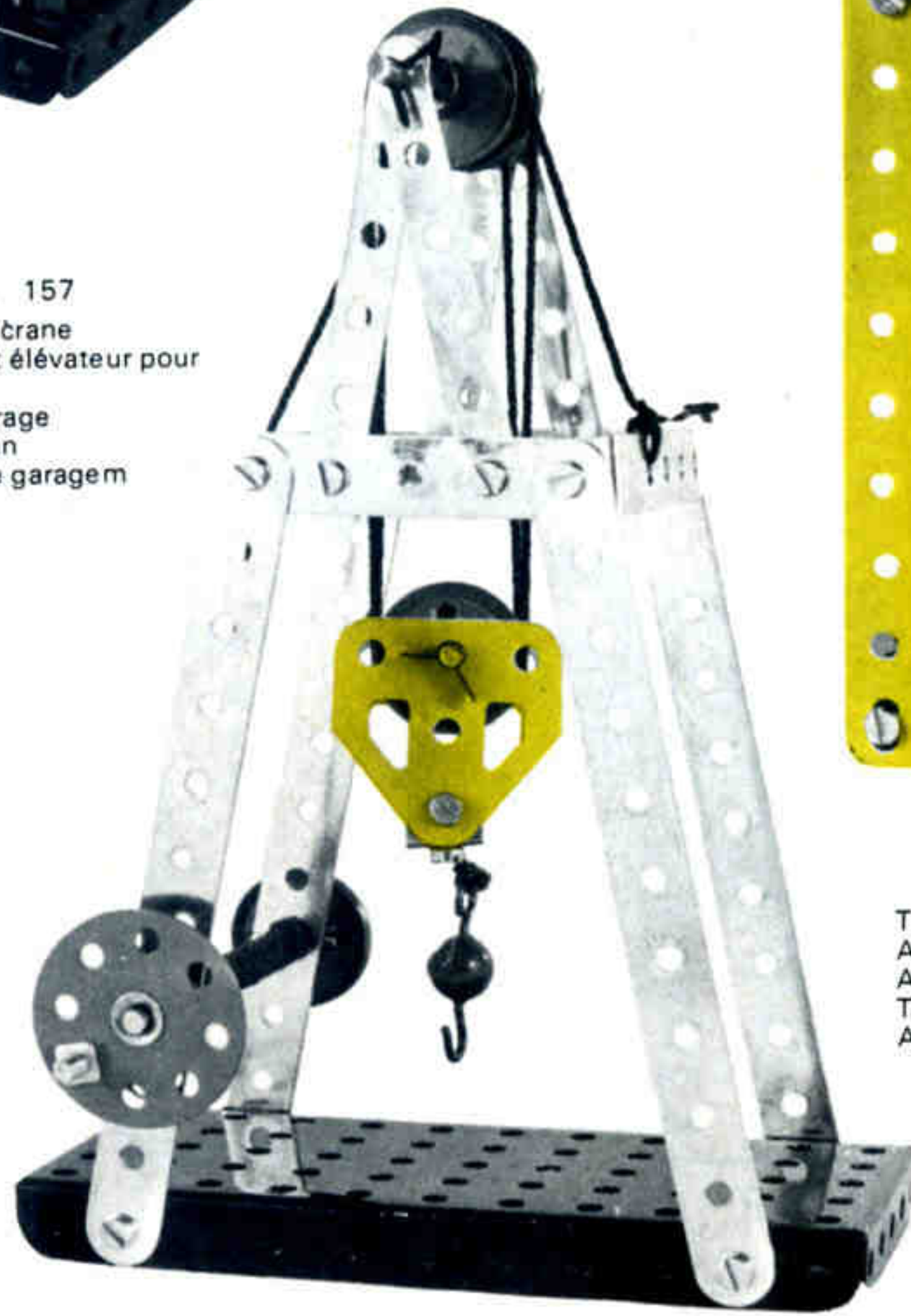

- TRAMPOLIN**  
3/156
- 2 - 2
  - 5 - 12
  - 2 - 22a
  - 19 - 37a
  - 17 - 37b
  - 1 - 52
  - 1 - 155

156  
Spring board  
Tremplin  
Trampolino  
Sprungbrett  
Trampolim

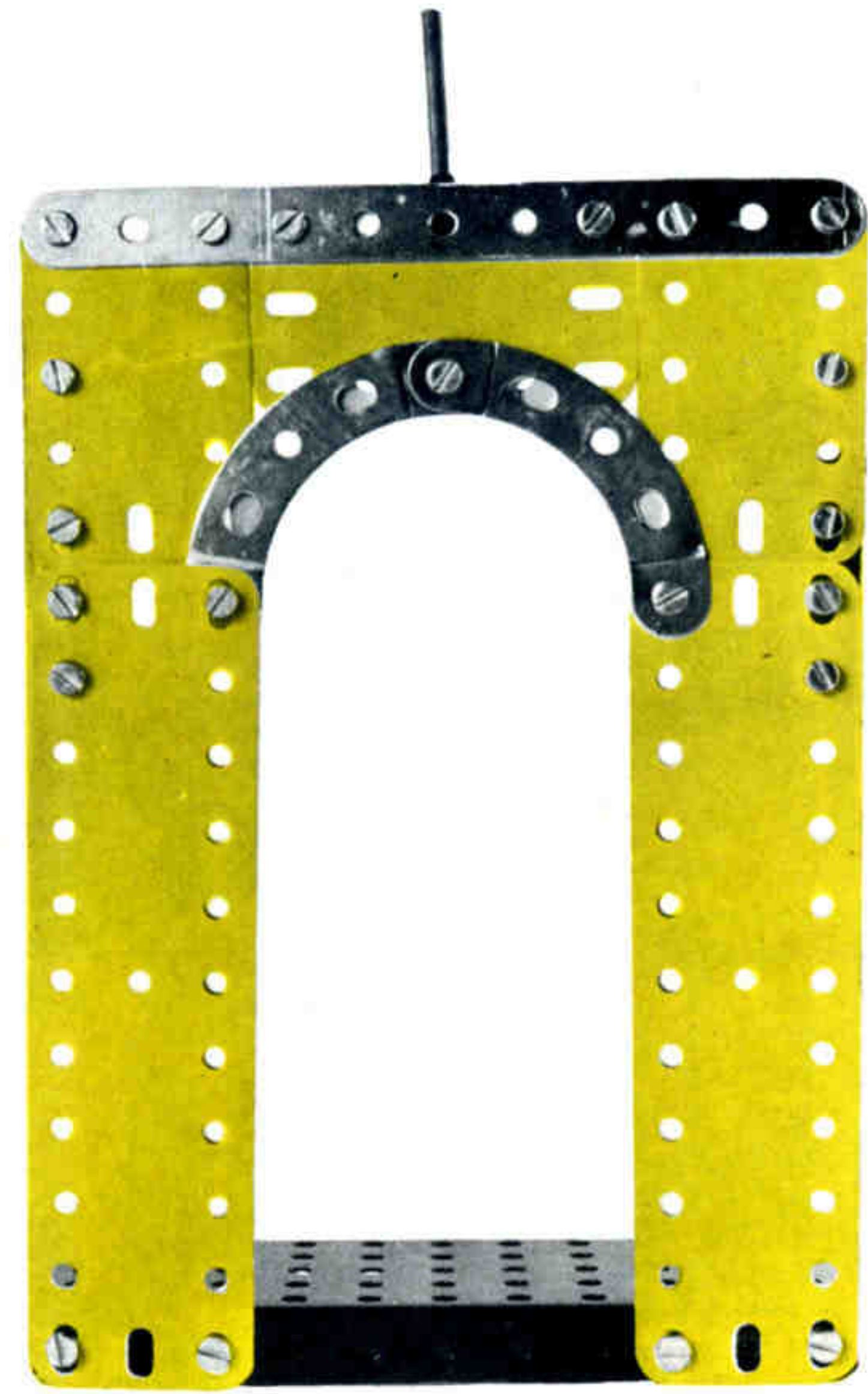

158  
The Arch of triumph  
Arc de triomphe  
Arco trionfo  
Triumpfbogen  
Arco Trunfo

- ARCO TRIUNFO**  
3/158
- 3 - 2
  - 2 - 5
  - 1 - 17
  - 21 - 37a
  - 21 - 37b
  - 2 - 35
  - 1 - 52
  - 2 - 90a
  - 1 - 190
  - 2 - 189
  - 2 - 188



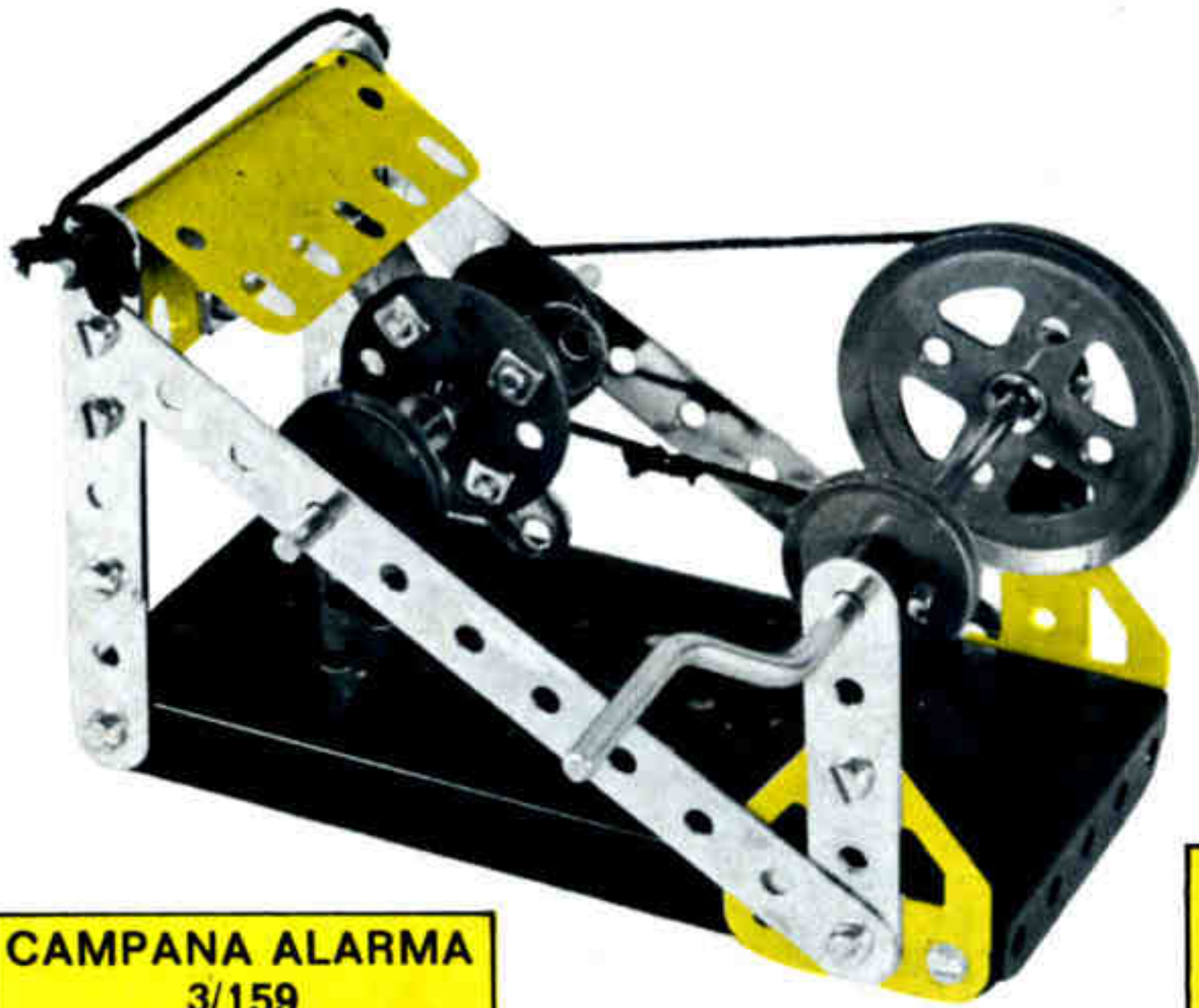

**CAMPANA ALARMA**  
3/159

|         |          |
|---------|----------|
| 2 - 2   | 2 - 35   |
| 6 - 5   | 19 - 37a |
| 4 - 10  | 19 - 37b |
| 2 - 16  | 4 - 38   |
| 1 - 19s | 1 - 52   |
| 1 - 20a | 2 - 126a |
| 3 - 22  | 1 - 199  |
| 1 - 24  |          |

159  
Alarm bell  
Sirène d'alarme  
Campana allarme  
Alarnglocke  
Campainha alarme

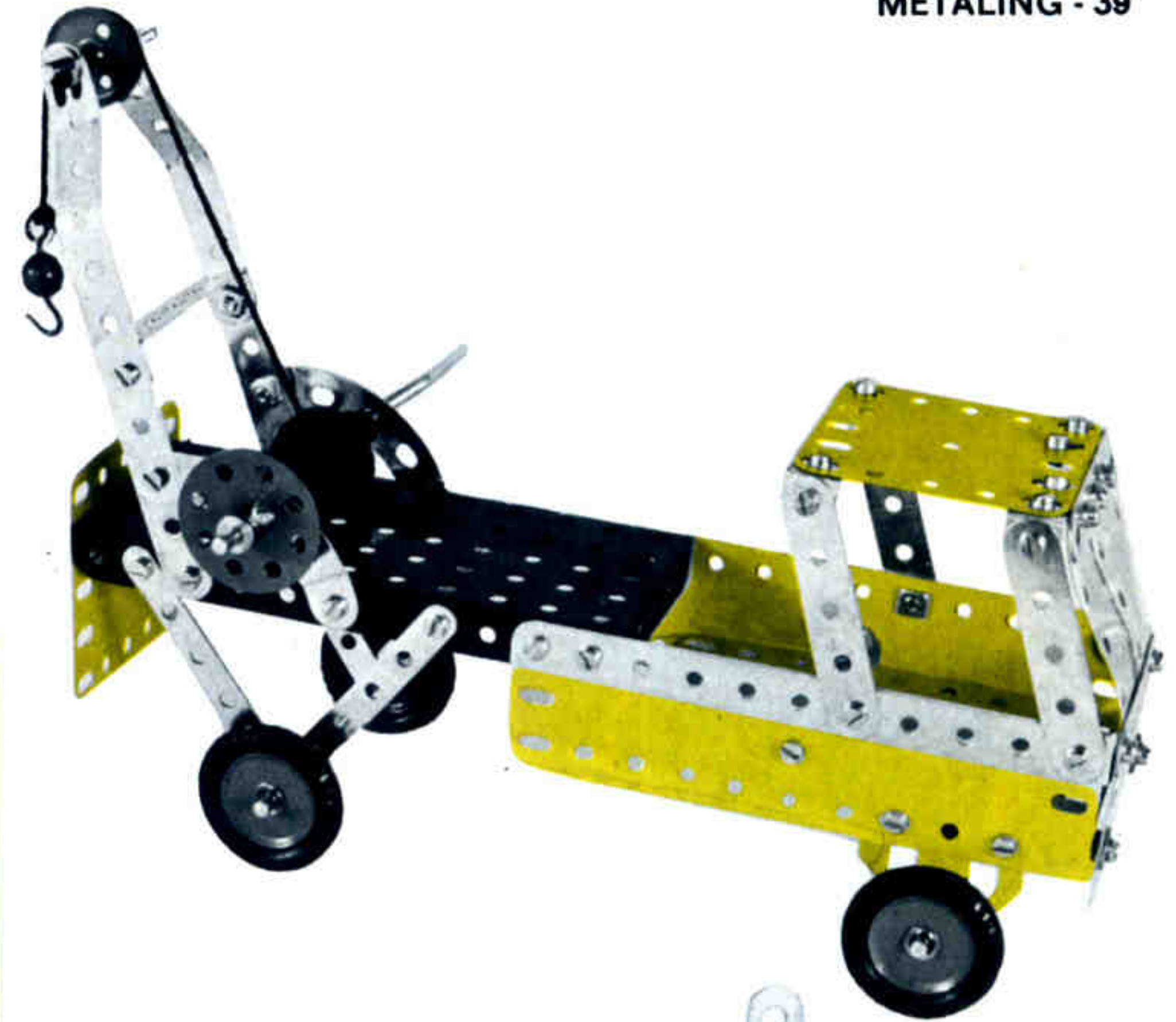

160  
Lorry crane  
Camion grue  
Camion gru  
Kranwagen  
Camiao-grua

**CAMION GRUA 3/160**

|         |          |          |
|---------|----------|----------|
| 4 - 2   | 48 - 37a | 2 - 126a |
| 6 - 5   | 47 - 37b | 4 - 142c |
| 8 - 12  | 4 - 38   | 2 - 188  |
| 1 - 17  | 1 - 40   | 2 - 189  |
| 1 - 19s | 2 - 48a  | 2 - 190  |
| 4 - 22  | 1 - 52   | 1 - 191  |
| 1 - 22a | 1 - 57c  | 2 - 193  |
| 1 - 24  | 2 - 90a  | 4 - 235a |
| 4 - 35  | 1 - 111c | 2 - 16   |

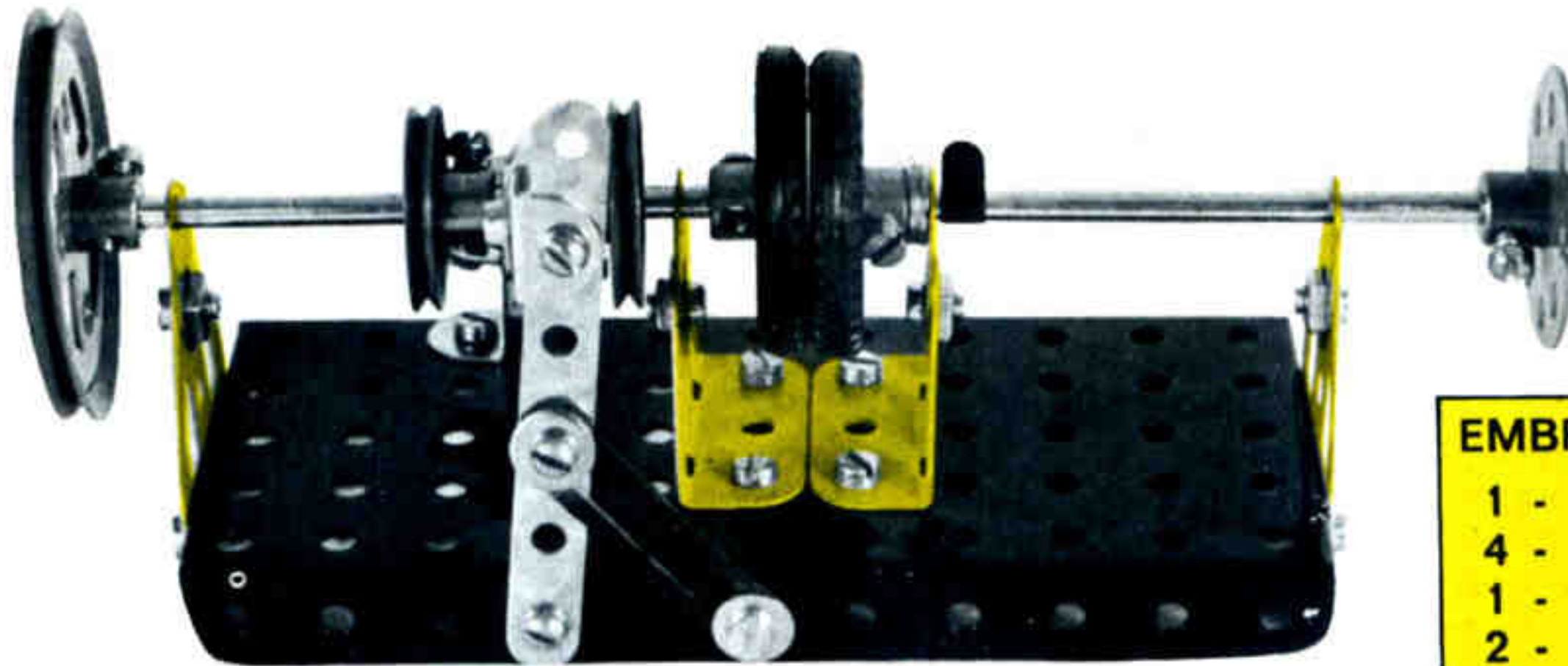

LOS NEUMATICOS 142C  
ACTUAN DE EMBRAGUE.

**EMBRAGUE A FRICCION 3/161**

|         |          |          |
|---------|----------|----------|
| 1 - 5   | 1 - 24   | 2 - 126  |
| 4 - 10  | 1 - 35   | 2 - 126a |
| 1 - 11  | 24 - 37a | 2 - 142c |
| 2 - 12  | 22 - 37b | 1 - 186  |
| 2 - 16  | 8 - 88   | 1 - 235a |
| 1 - 20a | 1 - 52   |          |
| 4 - 22  | 4 - 111c |          |

161  
Friction clutch the  
pneumatics 142C work  
as clutch  
Embrayage à friction  
Frizione  
Reibungskupplung  
Embraagem de friccao

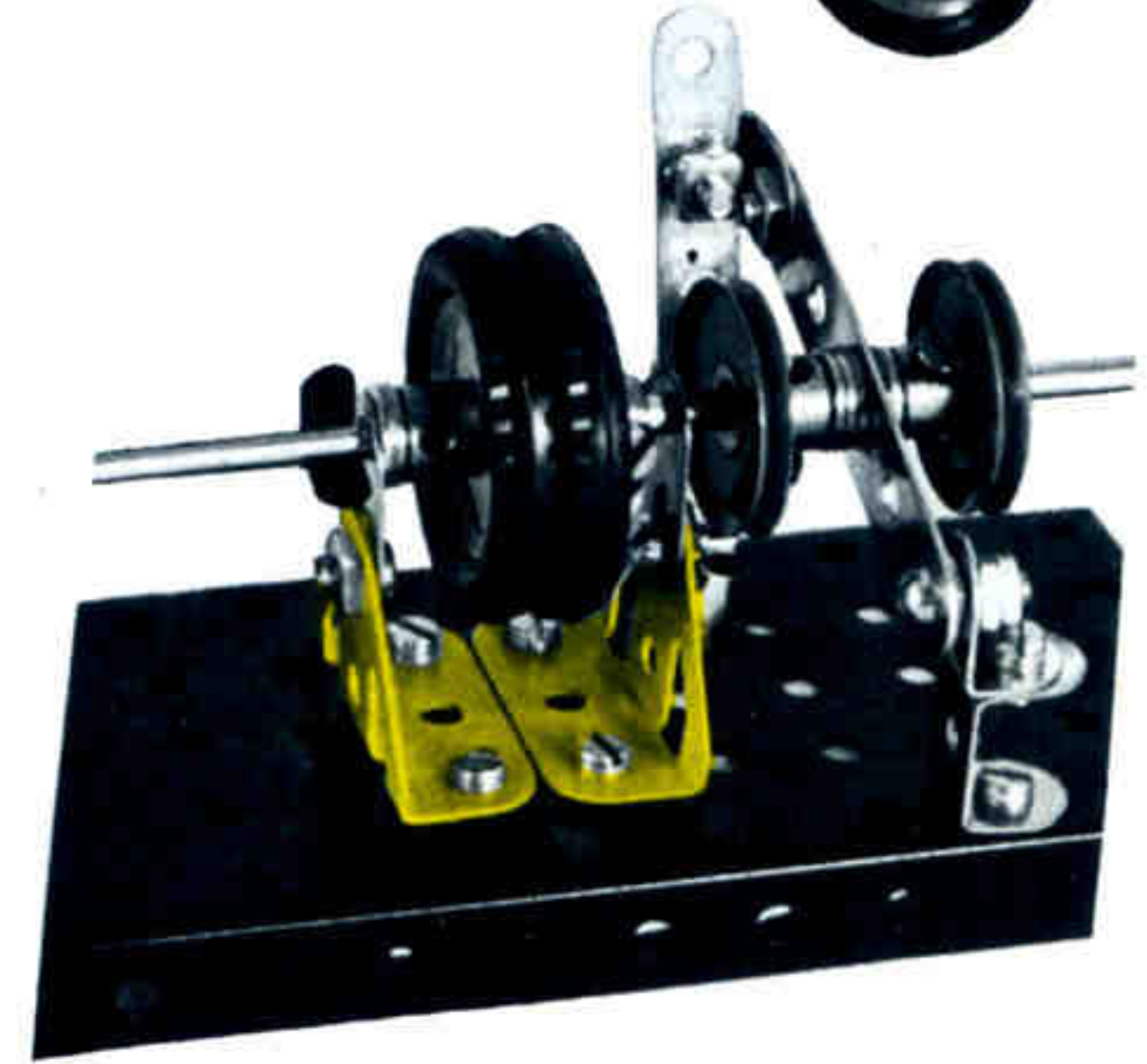

DETALLE POSTERIOR.



**SIERRA VERTICAL DE CARPINTERIA 3/162**

|         |          |          |
|---------|----------|----------|
| 1 - 2   | 2 - 35   | 1 - 90a  |
| 5 - 5   | 1 - 36   | 3 - 111c |
| 6 - 12  | 24 - 37a | 2 - 126  |
| 1 - 18b | 30 - 37b | 2 - 126a |
| 1 - 19s | 3 - 38   | 1 - 190  |
| 4 - 22  | 1 - 40   | 2 - 194a |
| 2 - 22a | 2 - 48a  |          |
| 2 - 34  | 1 - 52   |          |

162  
Vertical saw for carpenter  
Scie verticale pour charpentier  
Sega verticale di carpenteria  
Vertikalholzsäge  
Serra vertical de carpinteria

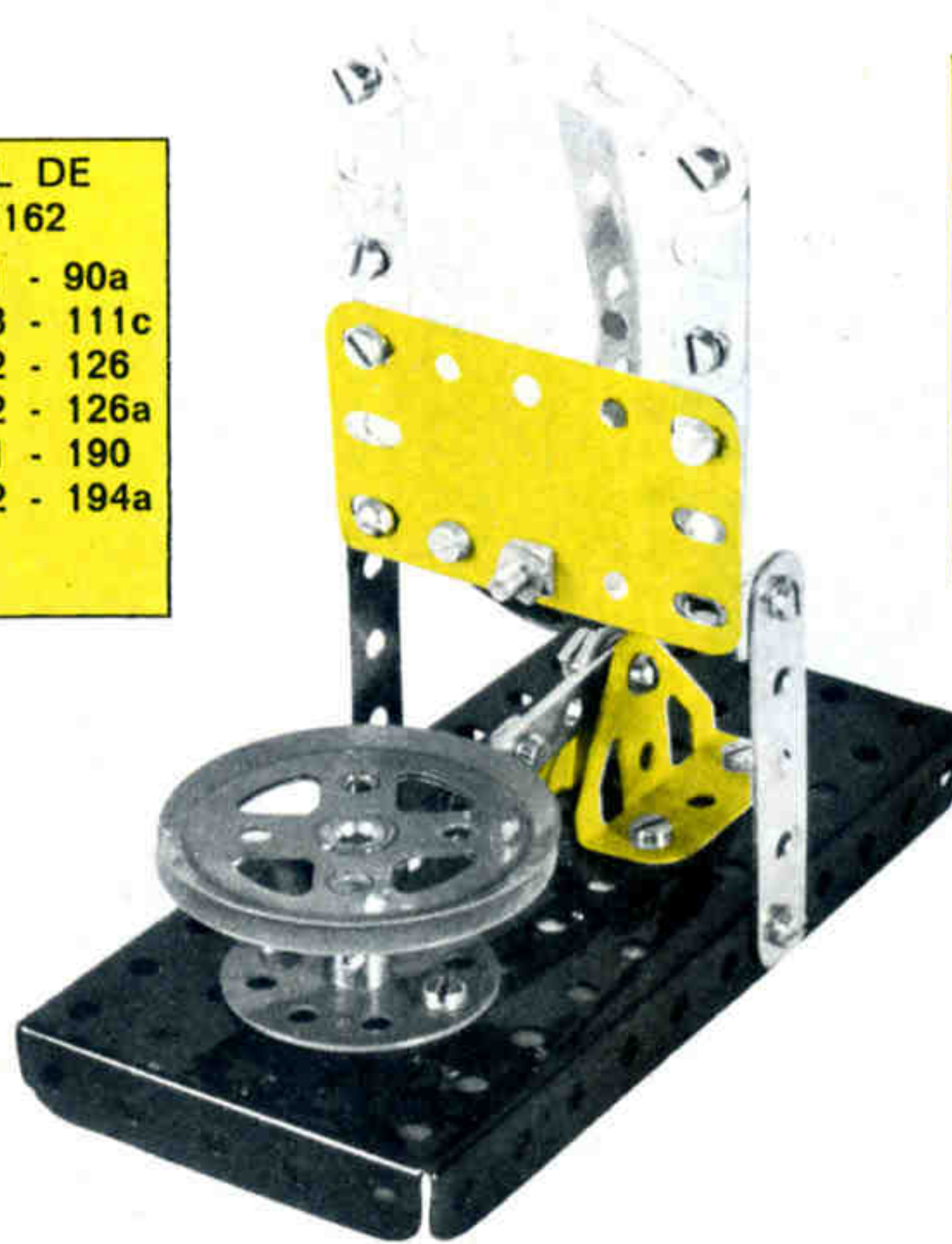

**BASCULA 3/163**

|          |          |
|----------|----------|
| 4 - 5    | 1 - 48a  |
| 1 - 11   | 1 - 52   |
| 1 - 12   | 1 - 90a  |
| 1 - 17   | 3 - 111c |
| 1 - 18b  | 2 - 126  |
| 1 - 20a  | 1 - 188  |
| 1 - 24   | 1 - 193  |
| 28 - 37a | 1 - 212  |
| 21 - 37b | 2 - 235a |
| 2 - 38   |          |

163  
Scale  
Bascule  
Basculla  
Hebelwaage  
Báscula



164  
Car  
Automobile  
Automobile  
Automobil  
Automóvel

**AUTOMOVIL 3/164**

|          |          |
|----------|----------|
| 3 - 2    | 2 - 90a  |
| 2 - 5    | 2 - 126  |
| 1 - 11   | 4 - 142c |
| 3 - 12   | 2 - 188  |
| 2 - 16   | 2 - 189  |
| 4 - 22   | 1 - 190  |
| 43 - 37a | 1 - 191  |
| 47 - 37b | 2 - 193  |
| 4 - 38   | 2 - 194  |
| 2 - 48a  | 2 - 194a |
| 1 - 52   |          |



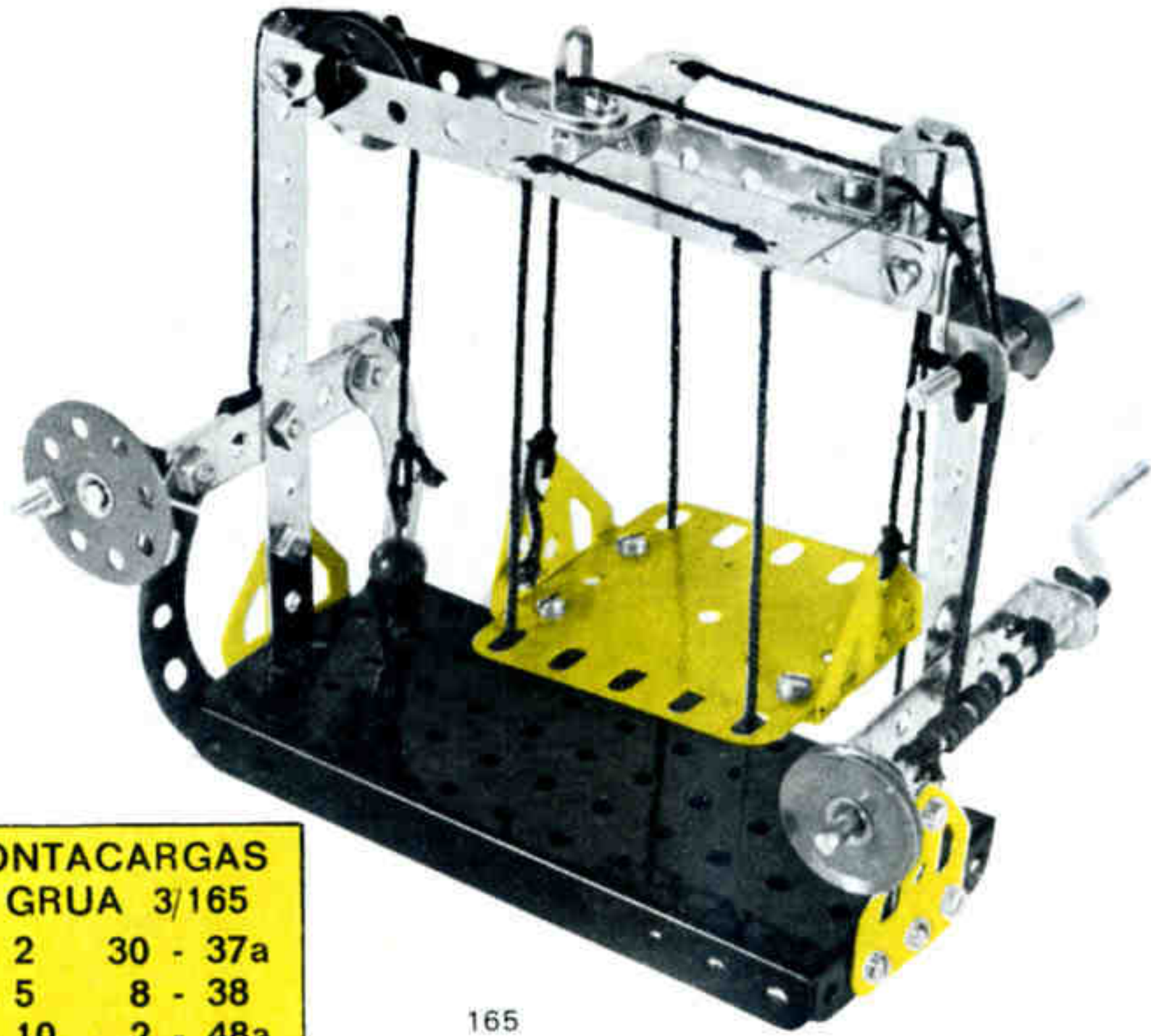

**MONTACARGAS Y GRUA 3/165**

|          |          |
|----------|----------|
| 4 - 2    | 30 - 37a |
| 2 - 5    | 8 - 38   |
| 1 - 10   | 2 - 48a  |
| 1 - 11   | 1 - 52   |
| 5 - 12   | 2 - 90a  |
| 1 - 16   | 1 - 111c |
| 1 - 19s  | 1 - 125  |
| 1 - 22   | 2 - 126  |
| 1 - 24   | 2 - 126a |
| 6 - 35   | 1 - 200  |
| 29 - 37b | 1 - 213  |

165  
Load lift and crane  
Monte-charges et grue  
Montacarichi e gru  
Lastenaufzug und Krank  
Monta-cargas e grua

**BARREDORA 3/166**

|          |          |
|----------|----------|
| 4 - 2    | 2 - 48a  |
| 6 - 5    | 1 - 52   |
| 2 - 10   | 4 - 111c |
| 8 - 12   | 1 - 125  |
| 2 - 16   | 2 - 126  |
| 2 - 17   | 4 - 142c |
| 1 - 19s  | 1 - 176  |
| 1 - 20a  | 2 - 188  |
| 4 - 22   | 2 - 189  |
| 2 - 22a  | 2 - 190  |
| 4 - 35   | 1 - 191  |
| 56 - 37a | 2 - 194  |
| 52 - 37b | 2 - 194a |
| 8 - 38   | 1 - 213  |
| 1 - 40   | 4 - 235a |

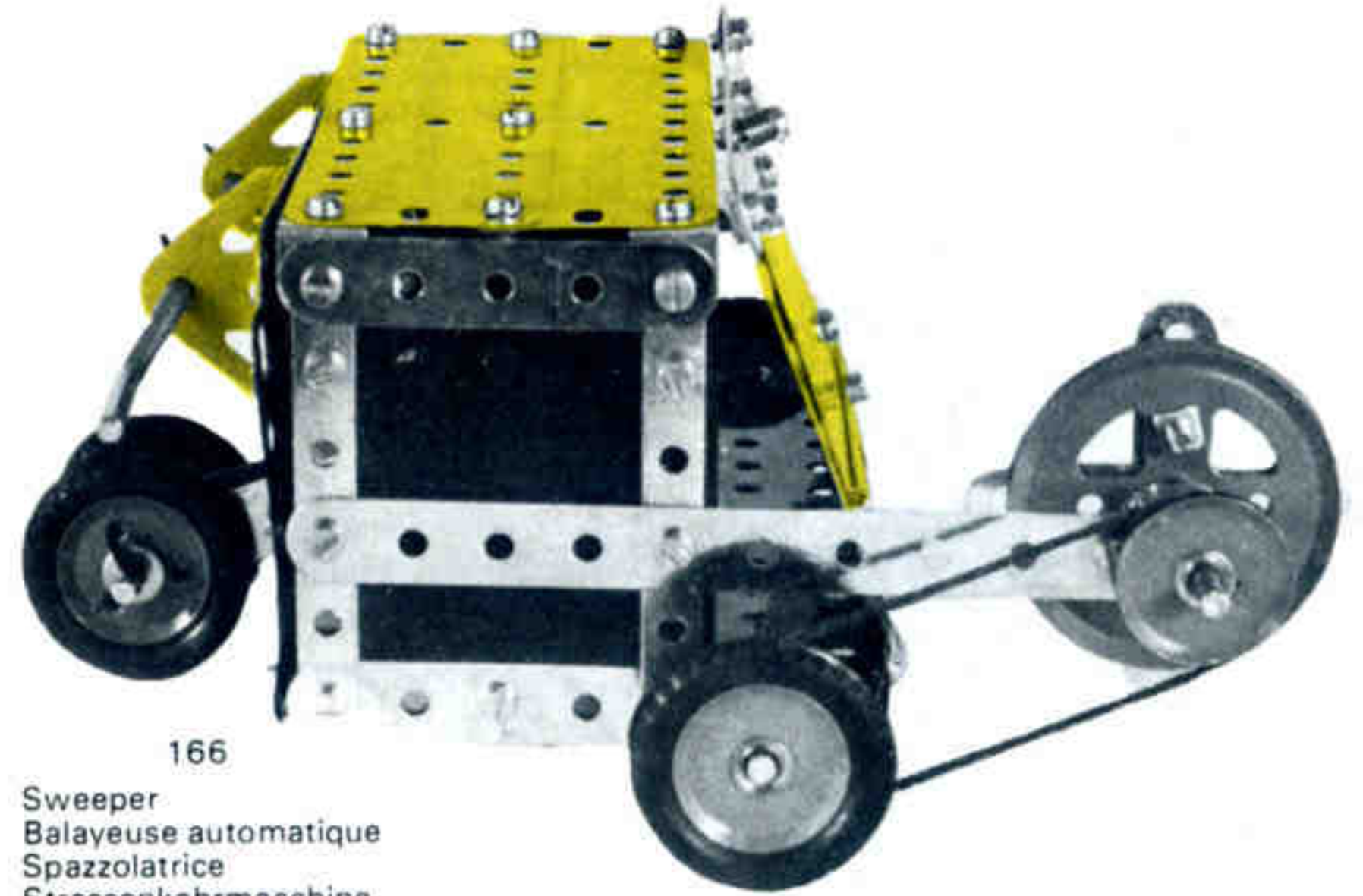

166  
Sweeper  
Balayeuse automatique  
Spazzolatrice  
Strassenkehrmaschine  
Varredora

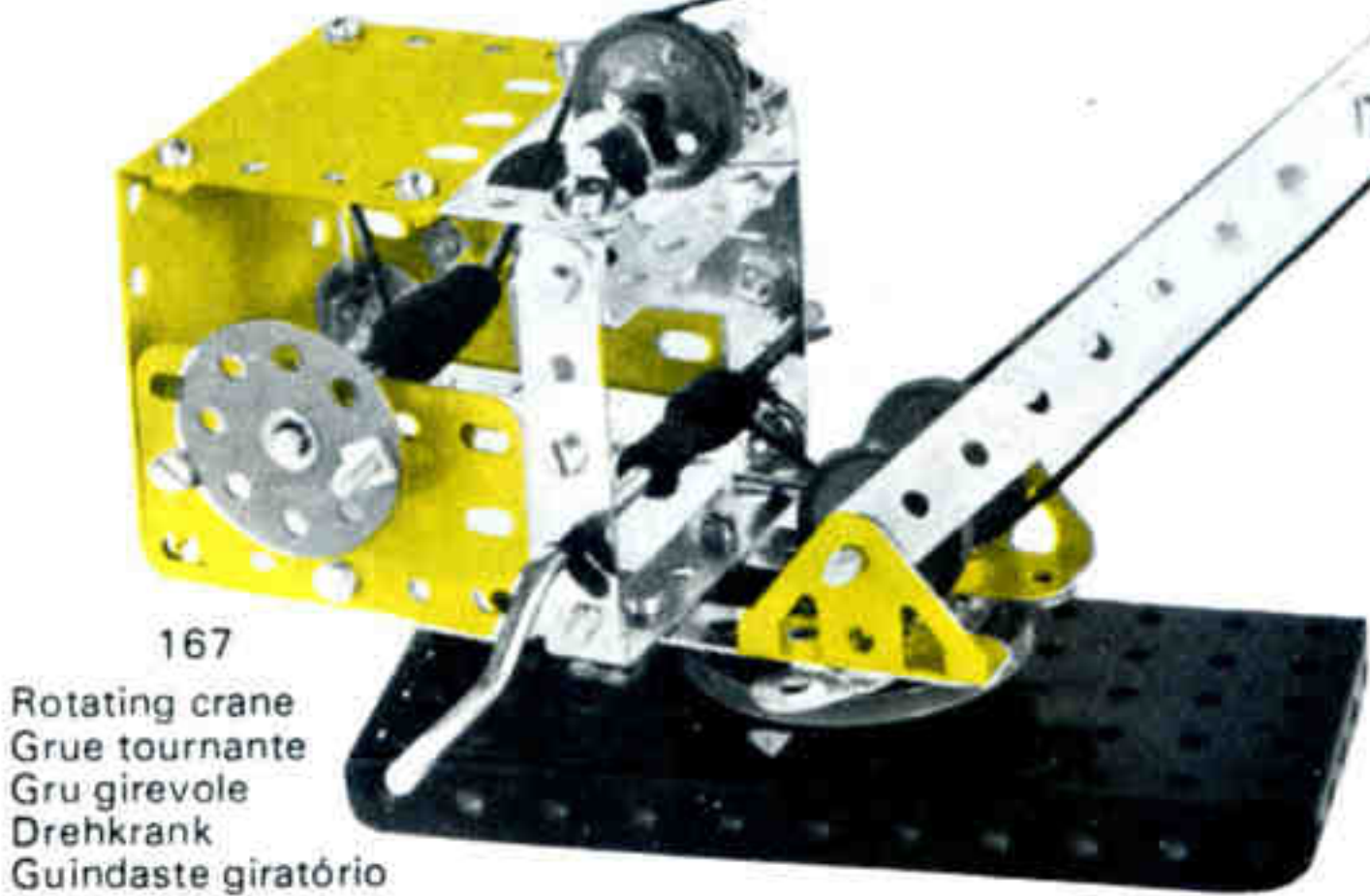

167  
Rotating crane  
Grue tournante  
Gru girevole  
Drehkrank  
Guindaste giratório

**GRUA GIRATORIA 3/167**

|         |
|---------|
| 4 - 2   |
| 6 - 5   |
| 1 - 11  |
| 6 - 12  |
| 1 - 16  |
| 2 - 17  |
| 1 - 18b |
| 1 - 19s |
| 1 - 20a |
| 4 - 22  |

**TALADRO 3/168**

|          |          |
|----------|----------|
| 4 - 2    | 27 - 37b |
| 3 - 5    | 5 - 38   |
| 3 - 12   | 2 - 48a  |
| 2 - 16   | 1 - 52   |
| 1 - 17   | 2 - 111c |
| 1 - 20a  | 2 - 126  |
| 4 - 22   | 1 - 126a |
| 1 - 24   | 1 - 142c |
| 2 - 35   | 2 - 188  |
| 29 - 37a | 2 - 194  |



168  
Drill  
Foreuse  
Trapano  
Bohrmaschine  
Máquina de furar



FRONTAL

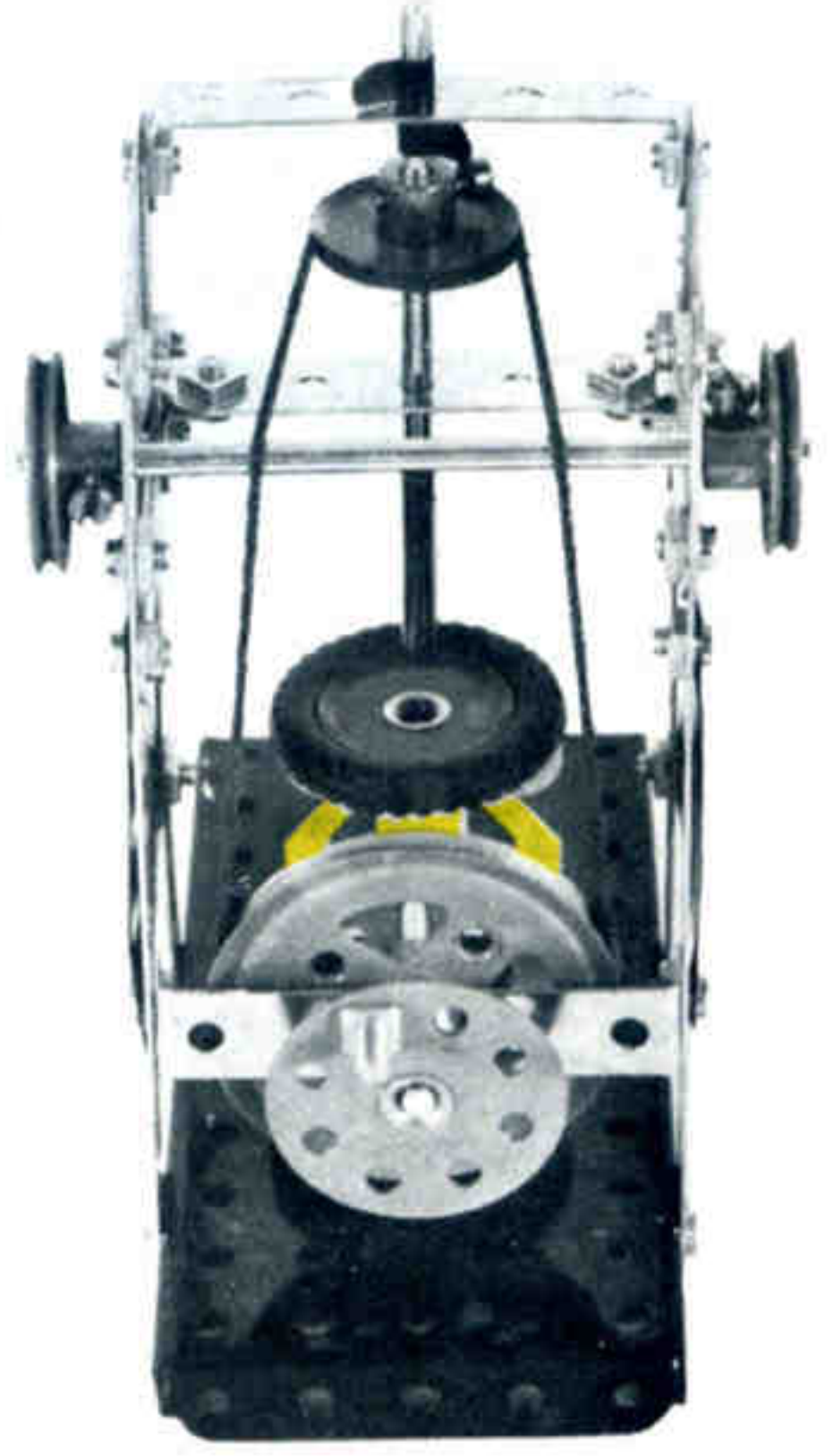

POSTERIOR.

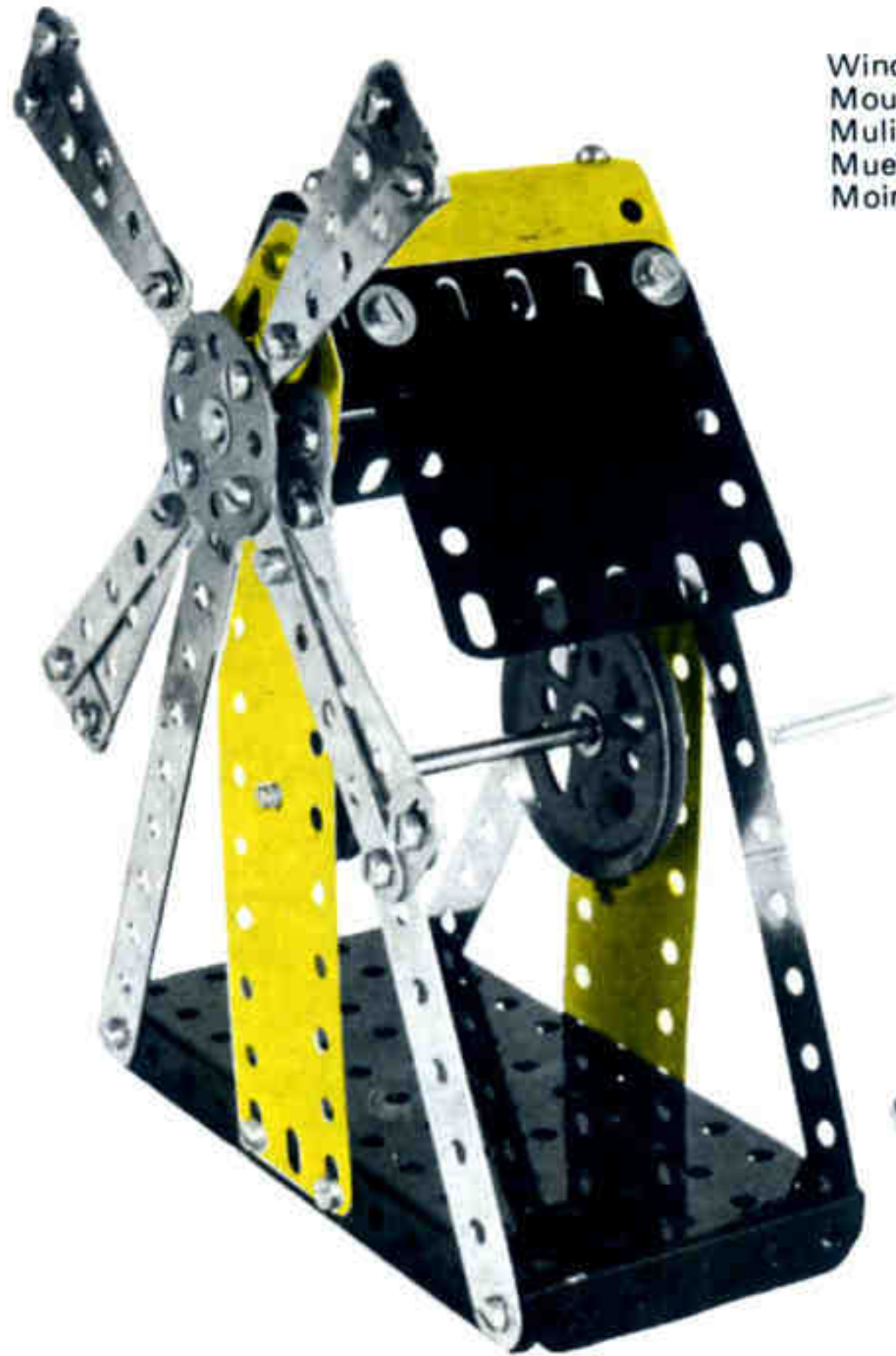

169  
Windmill  
Moulin à vent  
Mulino  
Muehle  
Moinho

| MOLINO 3/169 |          |
|--------------|----------|
| 4 - 2        | 1 - 36   |
| 4 - 5        | 4 - 38   |
| 4 - 10       | 1 - 48a  |
| 1 - 16       | 1 - 52   |
| 1 - 19s      | 2 - 111c |
| 1 - 20a      | 2 - 126a |
| 2 - 22       | 2 - 189  |
| 1 - 24       | 2 - 194a |
| 2 - 34       | 1 - 199  |
| 1 - 35       | 4 - 235a |

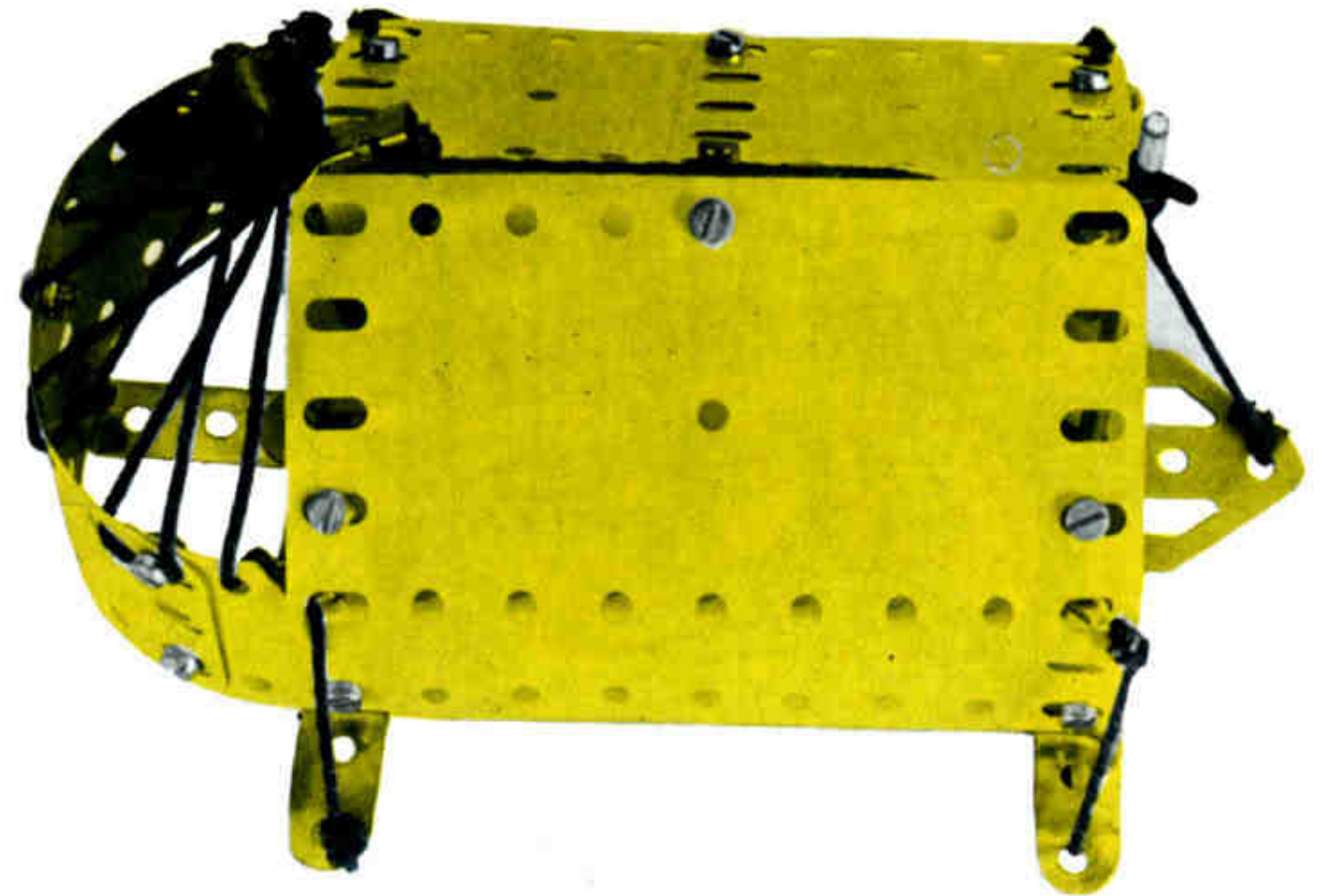

170  
Camping tent  
Tente de campagne  
Tenda de campanha  
Zelt  
Tenda de campanha

| TIENDA DE CAMPAÑA 3/170 |          |
|-------------------------|----------|
| 2 - 2                   | 1 - 125  |
| 4 - 10                  | 1 - 126a |
| 5 - 12                  | 2 - 188  |
| 2 - 16                  | 2 - 189  |
| 5 - 35                  | 2 - 190  |
| 30 - 37a                | 1 - 191  |
| 30 - 37b                | 1 - 212  |
| 1 - 48a                 |          |

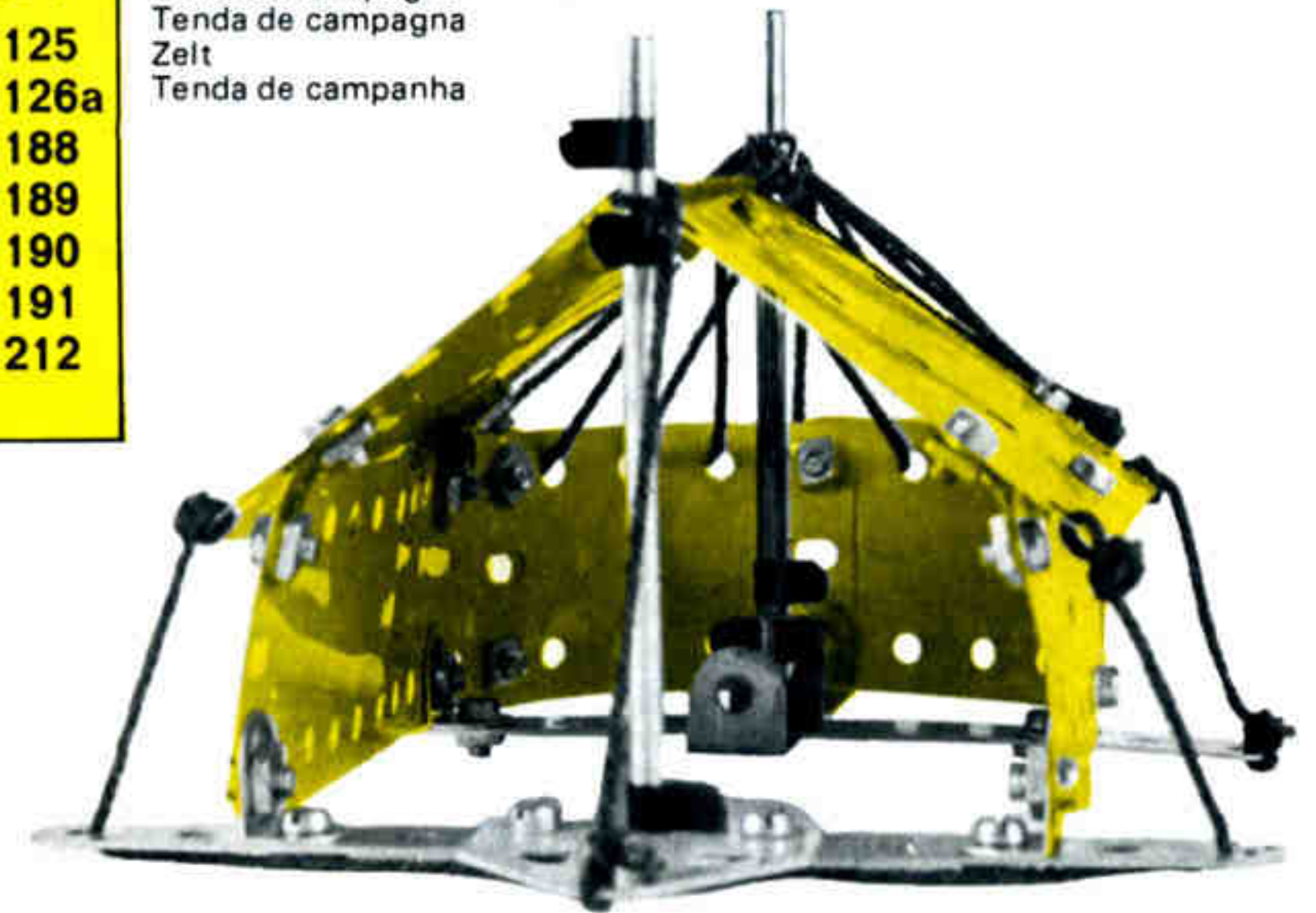

PARA ADQUIRIR VELOCIDAD, LA CUERDA PASA SOBRE EL DIJE DE LA POLEA N.º 22.

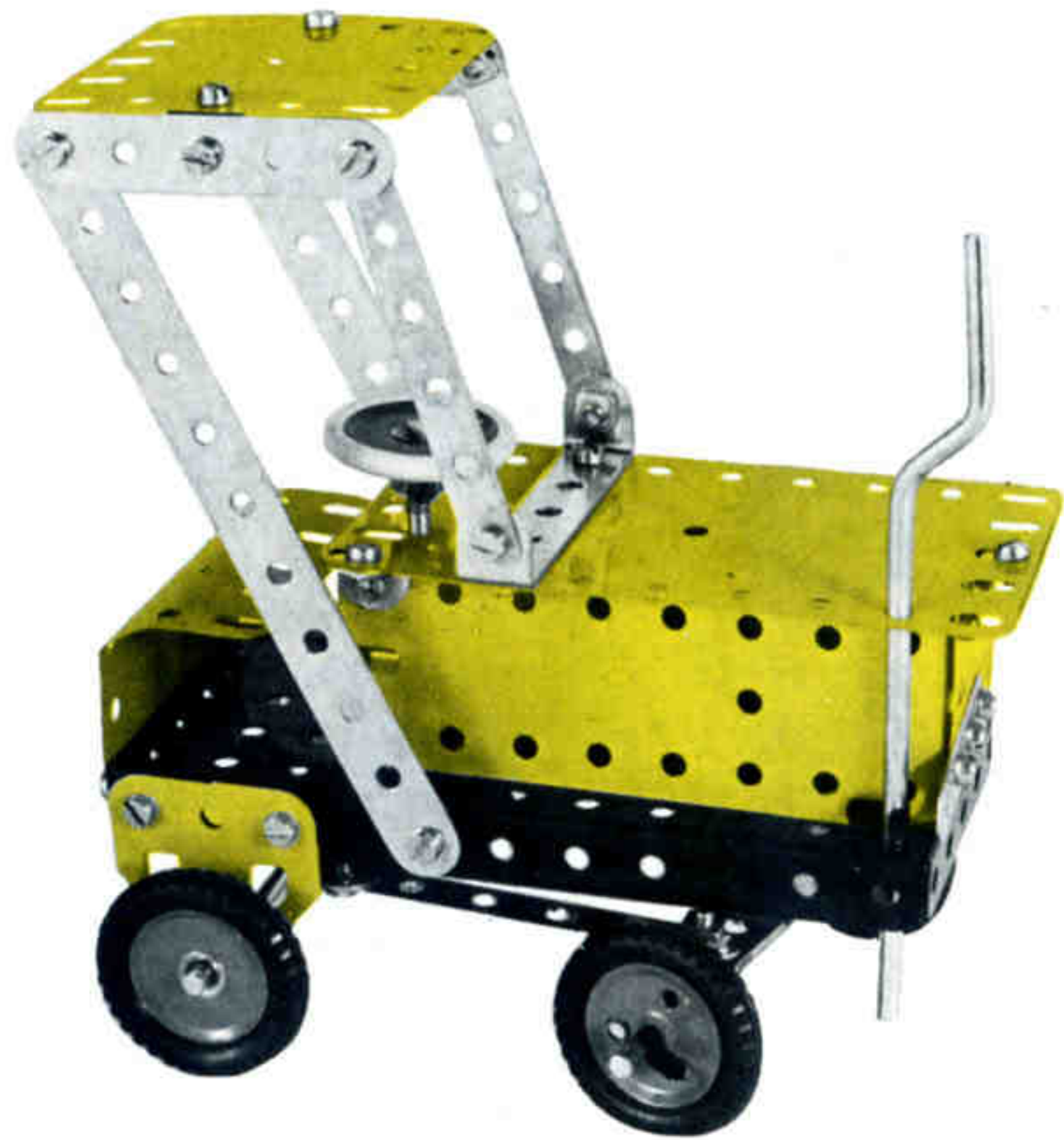

171  
Tractor  
Tracteur  
Trattore  
Traktor  
Tractor

| TRACTOR 3/171 |          |          |  |  |  |
|---------------|----------|----------|--|--|--|
| 2 - 2         | 1 - 24   | 2 - 126a |  |  |  |
| 5 - 5         | 4 - 35   | 4 - 142c |  |  |  |
| 1 - 11        | 48 - 37a | 1 - 155  |  |  |  |
| 8 - 12        | 40 - 37b | 1 - 176  |  |  |  |
| 2 - 16        | 8 - 38   | 2 - 189  |  |  |  |
| 2 - 17        | 2 - 48a  | 2 - 190  |  |  |  |
| 1 - 18b       | 1 - 52   | 1 - 191  |  |  |  |
| 1 - 19s       | 4 - 111c | 1 - 213  |  |  |  |
| 3 - 22        | 1 - 125  | 4 - 235a |  |  |  |
| 2 - 22a       | 2 - 126  |          |  |  |  |

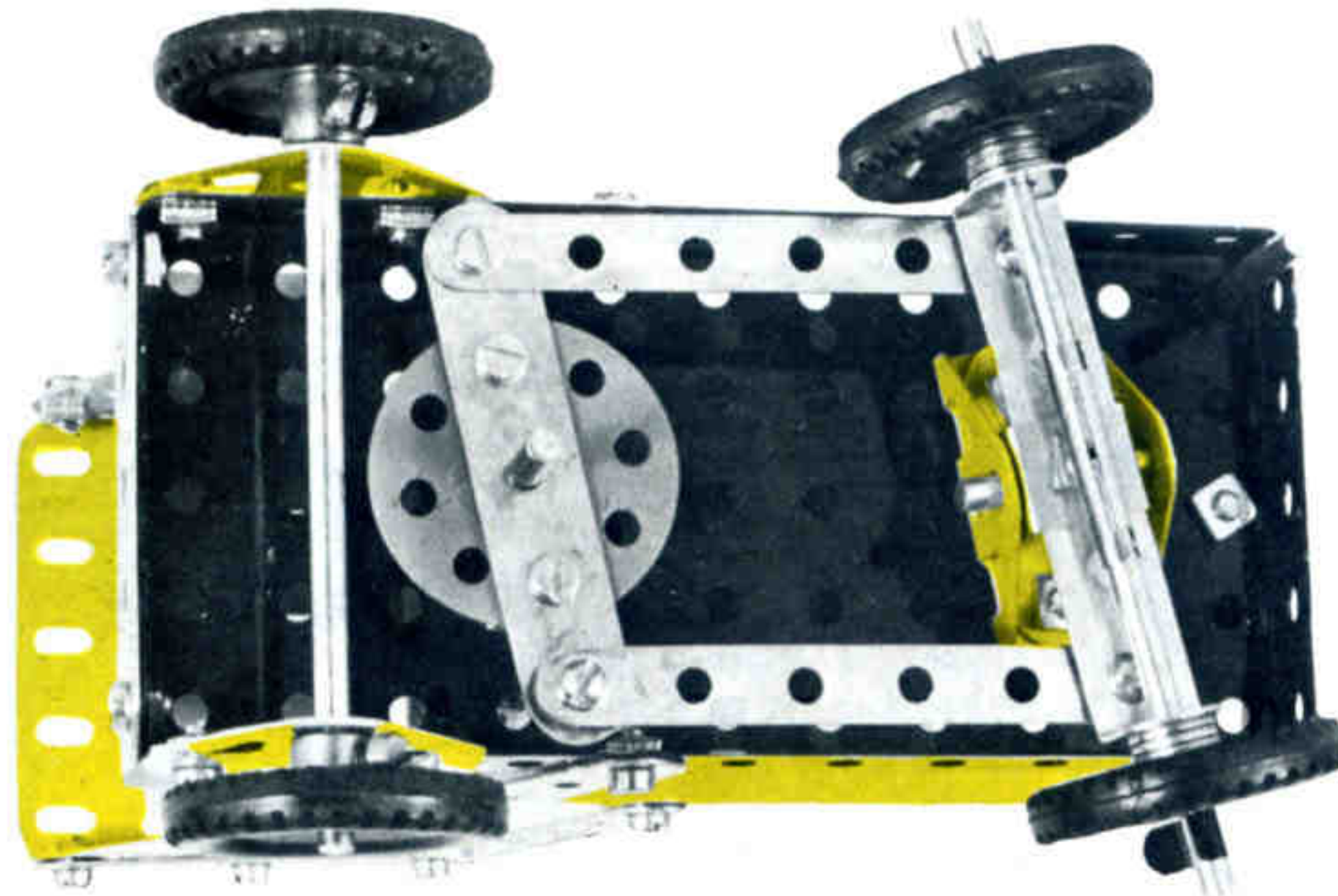

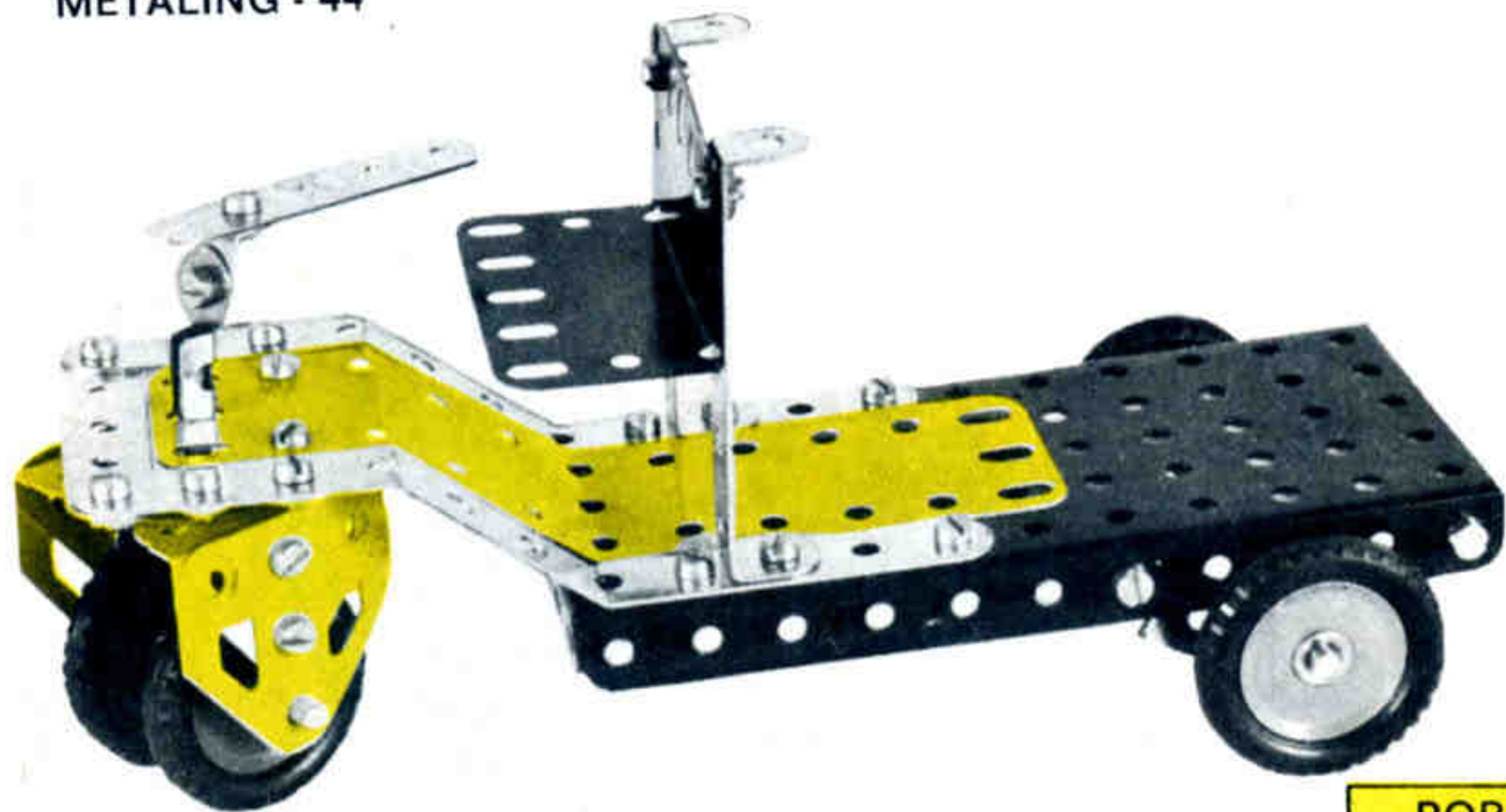

**ESCALERA AEROPUERTO**  
3/174

|         |          |          |
|---------|----------|----------|
| 4 - 2   | 3 - 35   | 2 - 126  |
| 2 - 10  | 32 - 37a | 4 - 142c |
| 7 - 12  | 37 - 37b | 2 - 190  |
| 2 - 16  | 4 - 38   | 1 - 193  |
| 1 - 17  | 1 - 48a  | 2 - 194a |
| 1 - 18b | 1 - 52   | 1 - 199  |
| 4 - 22  | 2 - 90a  | 1 - 212  |
| 1 - 24  | 1 - 125  | 4 - 235a |

**CARRETILLA**  
**SERVICIO 3/172**

|          |          |
|----------|----------|
| 2 - 2    | 5 - 38   |
| 4 - 5    | 2 - 48a  |
| 1 - 12   | 1 - 52   |
| 1 - 16   | 2 - 90a  |
| 1 - 17   | 2 - 126  |
| 1 - 18b  | 1 - 126a |
| 4 - 22   | 4 - 142c |
| 1 - 22a  | 1 - 189  |
| 1 - 24   | 1 - 194a |
| 28 - 37a | 1 - 212  |
| 28 - 37b |          |

172  
Service trolley  
Chariot de service  
Cariola servizio  
Elektrokarren  
Carretilha de servico

**PORTAVIONES**  
3/173

|          |          |
|----------|----------|
| 4 - 2    | 4 - 111c |
| 2 - 10   | 1 - 125  |
| 1 - 11   | 2 - 126  |
| 6 - 12   | 2 - 189  |
| 1 - 17   | 2 - 190  |
| 1 - 18b  | 1 - 191  |
| 2 - 35   | 1 - 194  |
| 40 - 37a | 1 - 212  |
| 34 - 37b |          |

173  
Aircraft carrier  
Porte-avions  
Portaerei  
Flugzeugtraeger  
Porta-avioes

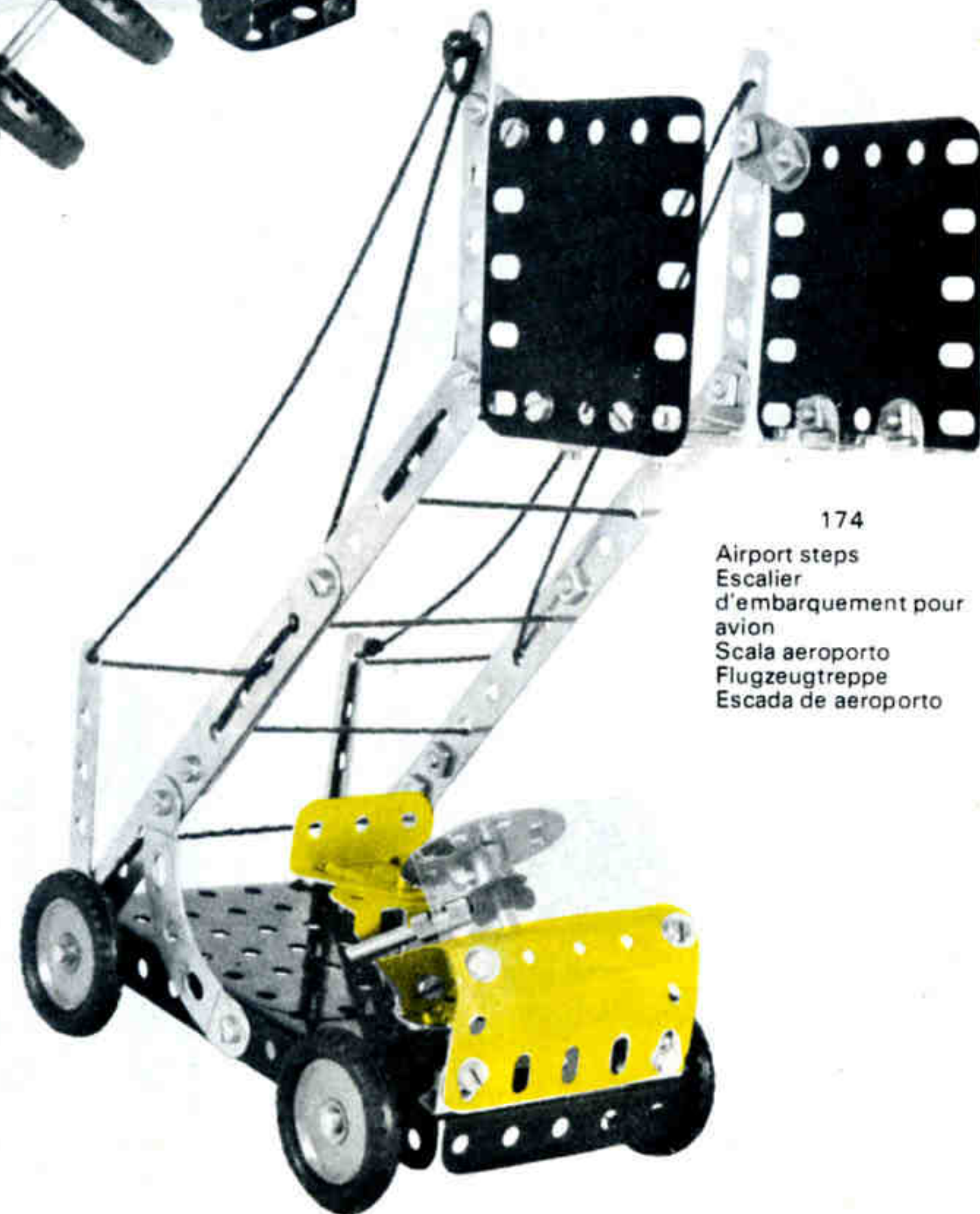
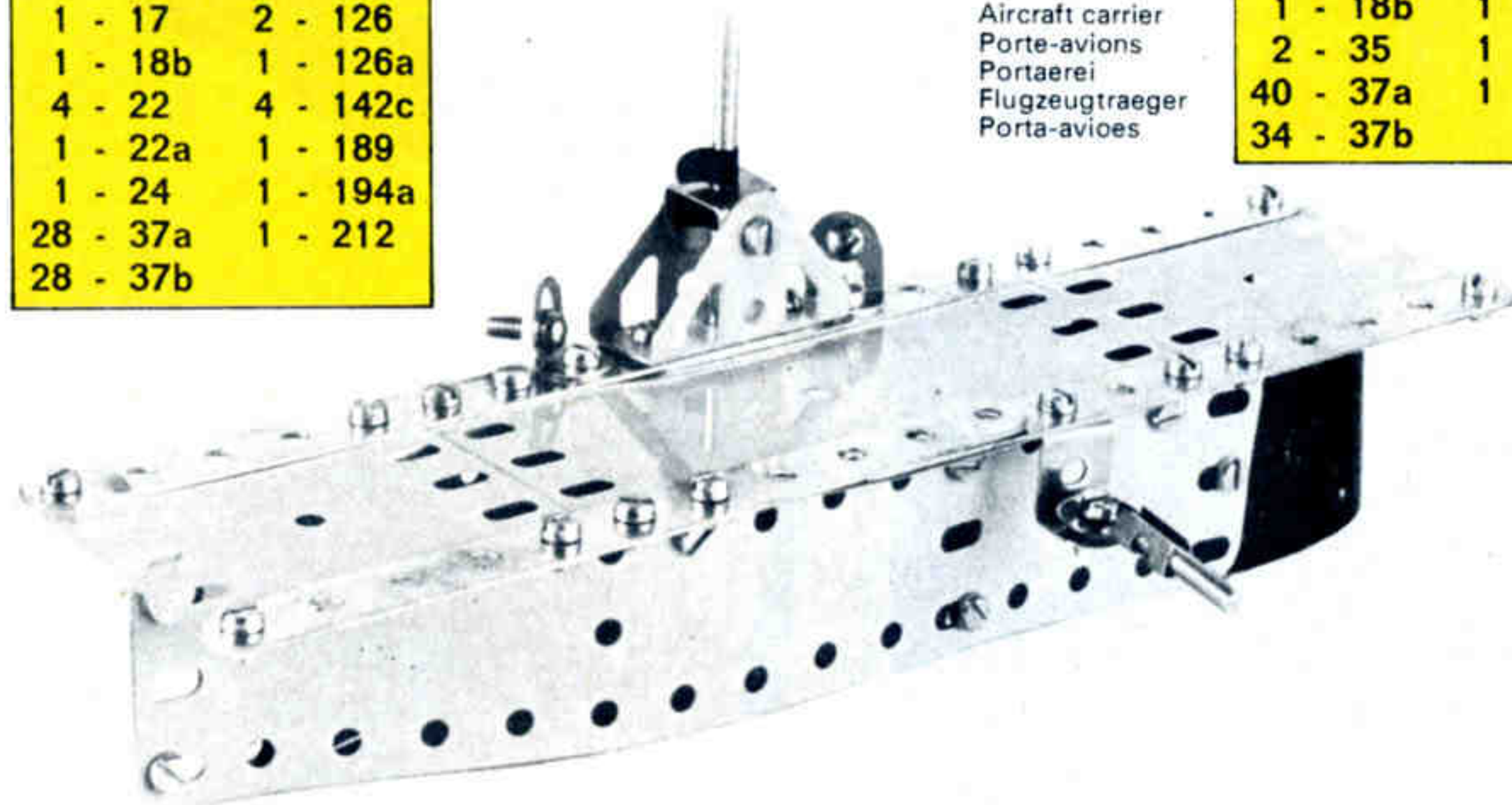

174  
Airport steps  
Escalier  
d'embarquement pour  
avion  
Scala aeroporto  
Flugzeugtreppe  
Escada de aeroporto



175  
Tricycle and cyclist  
Tricycle et son cycliste  
Triciclo e ciclista  
Dreirad mit Radfahrer  
Triciclo e ciclista

| TRICICLO Y CICLISTA<br>3/175 |          |          |  |
|------------------------------|----------|----------|--|
| 2 - 2                        | 1 - 24   | 1 - 125  |  |
| 6 - 5                        | 2 - 34   | 2 - 126  |  |
| 4 - 10                       | 6 - 35   | 2 - 142c |  |
| 1 - 11                       | 1 - 36   | 1 - 155  |  |
| 8 - 12                       | 50 - 37a | 1 - 188  |  |
| 1 - 16                       | 48 - 37b | 2 - 189  |  |
| 2 - 17                       | 6 - 38   | 1 - 190  |  |
| 1 - 20a                      | 1 - 52   | 1 - 193  |  |
| 2 - 22                       | 2 - 90a  | 1 - 199  |  |
| 1 - 22a                      | 2 - 111c | 4 - 235a |  |

176  
Jeep  
Jeep  
Jeep  
Jeep  
Jeep

| JEEP 3/176 |          |  |  |
|------------|----------|--|--|
| 4 - 2      | 1 - 48a  |  |  |
| 4 - 5      | 1 - 52   |  |  |
| 1 - 11     | 3 - 111c |  |  |
| 5 - 12     | 4 - 142c |  |  |
| 2 - 16     | 2 - 155  |  |  |
| 4 - 22     | 2 - 189  |  |  |
| 2 - 22a    | 2 - 194a |  |  |
| 34 - 37a   | 1 - 193  |  |  |
| 27 - 37b   | 2 - 235a |  |  |



178  
Transportable crane  
Grue transportable  
Gru transportabile  
Transportkran  
Grua transportável

| GRUA TRANSPORTABLE 3/178 |          |          |          |
|--------------------------|----------|----------|----------|
| 2 - 2                    | 1 - 20a  | 50 - 37b | 1 - 125  |
| 3 - 5                    | 4 - 22   | 10 - 38  | 2 - 126  |
| 1 - 10                   | 2 - 22a  | 1 - 40   | 4 - 142c |
| 1 - 11                   | 1 - 24   | 2 - 48a  | 1 - 155  |
| 8 - 12                   | 2 - 34   | 1 - 52   | 2 - 188  |
| 2 - 16                   | 4 - 35   | 1 - 57c  | 1 - 190  |
| 1 - 18b                  | 1 - 36   | 2 - 90a  | 1 - 199  |
| 1 - 19s                  | 54 - 37a | 1 - 111c | 2 - 235a |

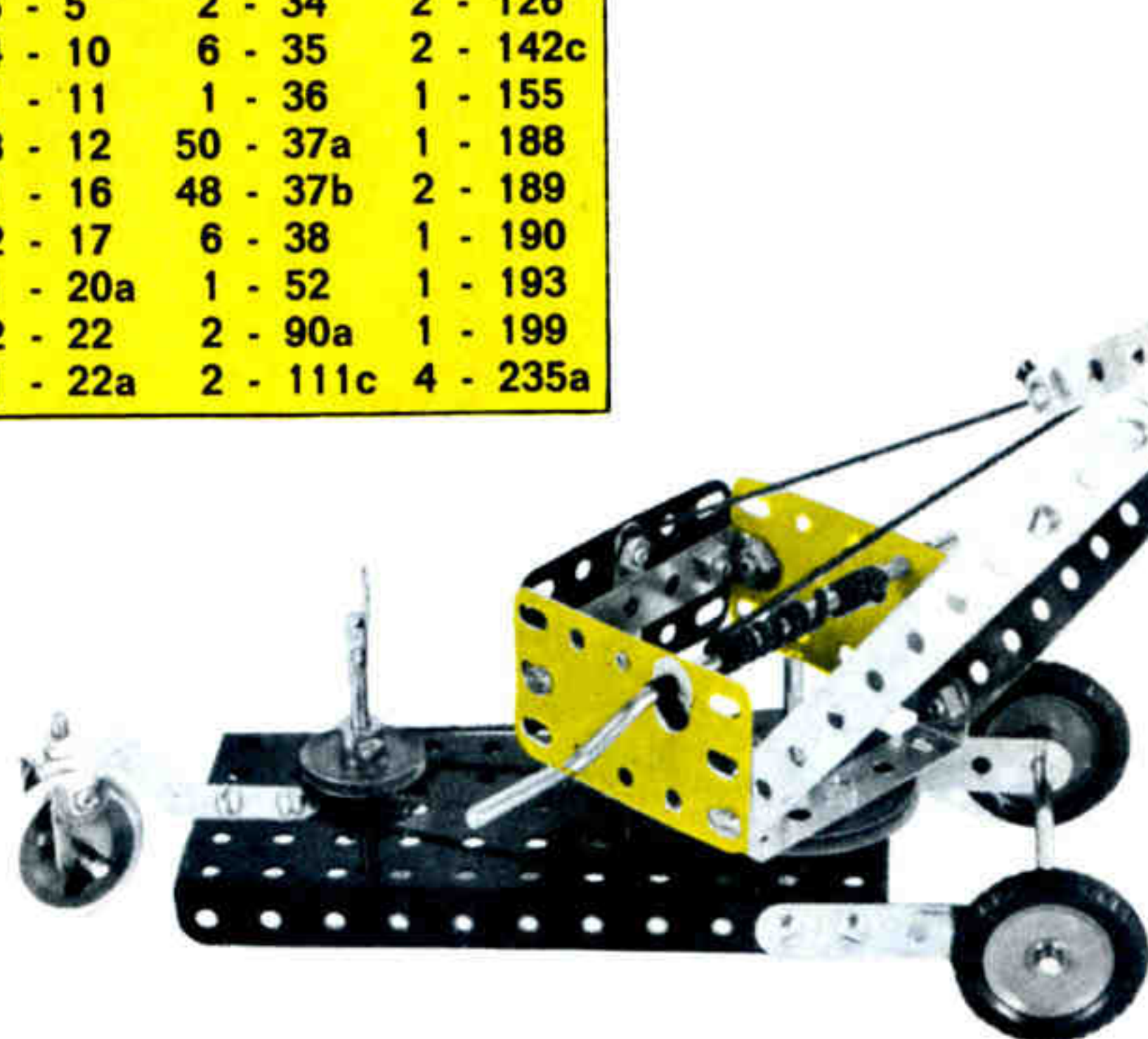

| GRUA MOVIL 3/177 |          |          |
|------------------|----------|----------|
| 4 - 2            | 4 - 22   | 3 - 111c |
| 5 - 5            | 1 - 24   | 2 - 142c |
| 2 - 10           | 4 - 35   | 1 - 155  |
| 1 - 11           | 30 - 37a | 2 - 188  |
| 2 - 12           | 22 - 37b | 1 - 194  |
| 1 - 16           | 6 - 38   | 1 - 212  |
| 2 - 17           | 2 - 48a  | 1 - 235a |
| 1 - 19s          | 1 - 52   | 2 - 22a  |
| 1 - 20a          | 1 - 57c  |          |

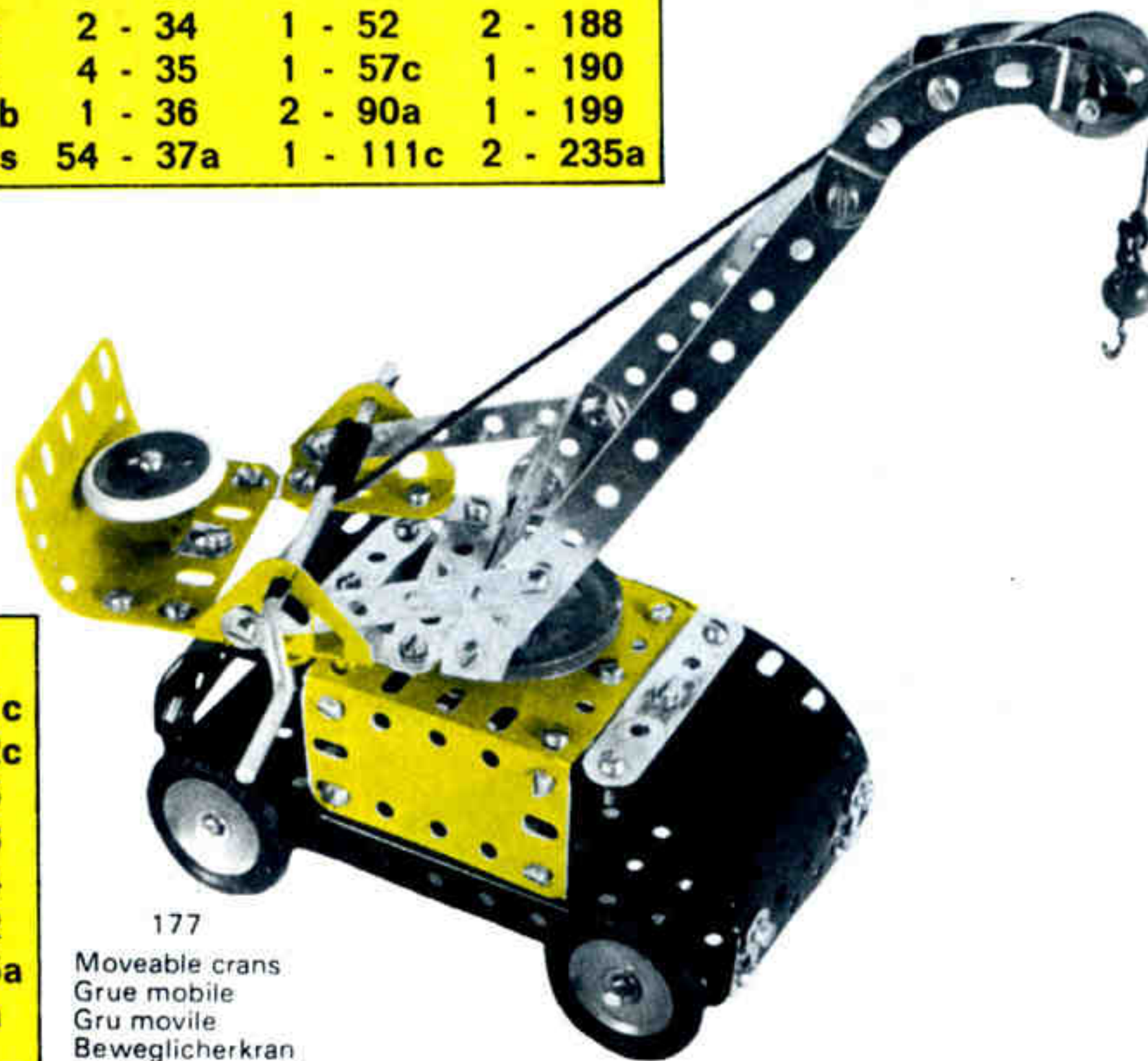

177  
Moveable crans  
Grue mobile  
Gru mobile  
Beweglicherkran  
Guindaste móvel

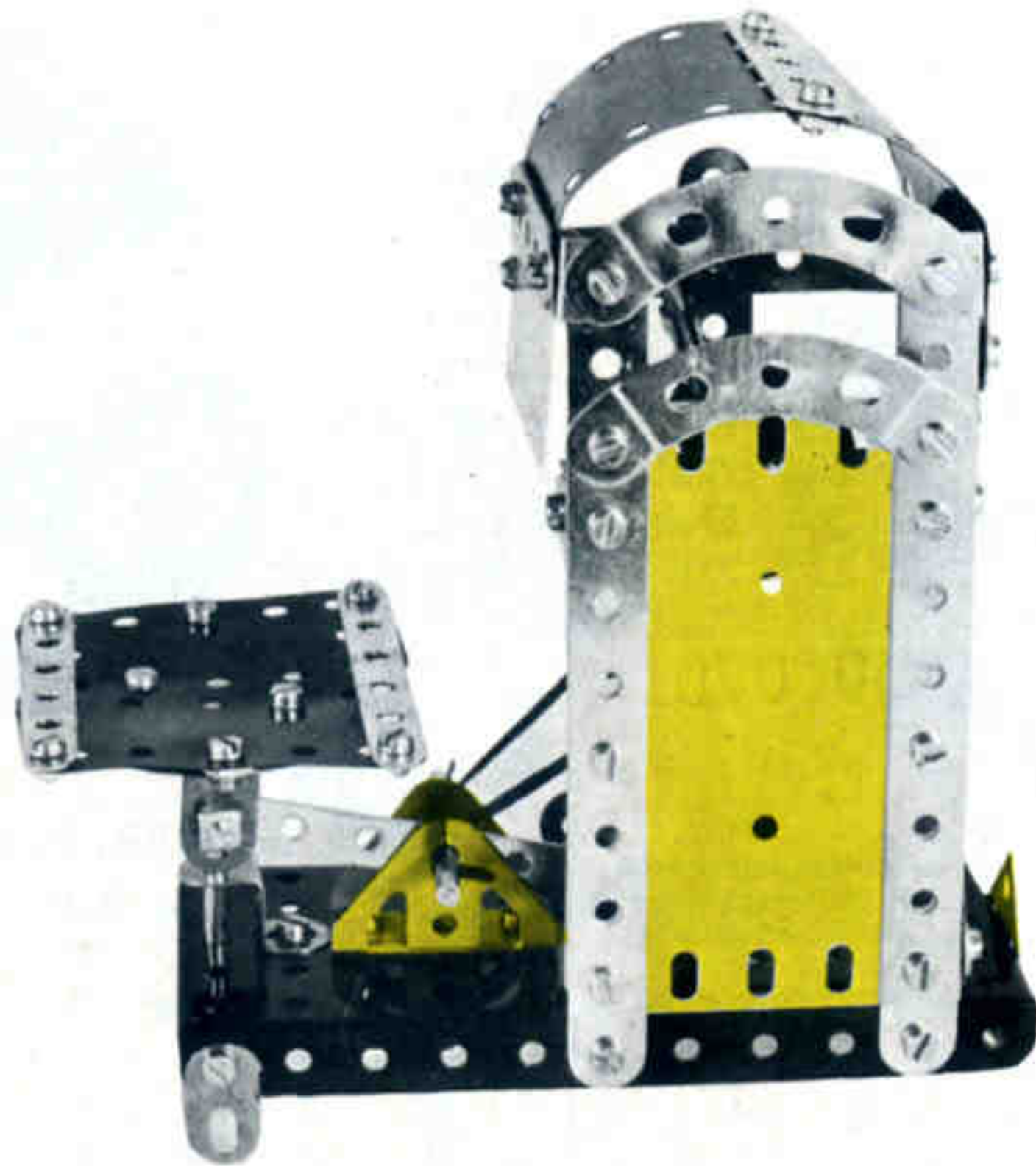
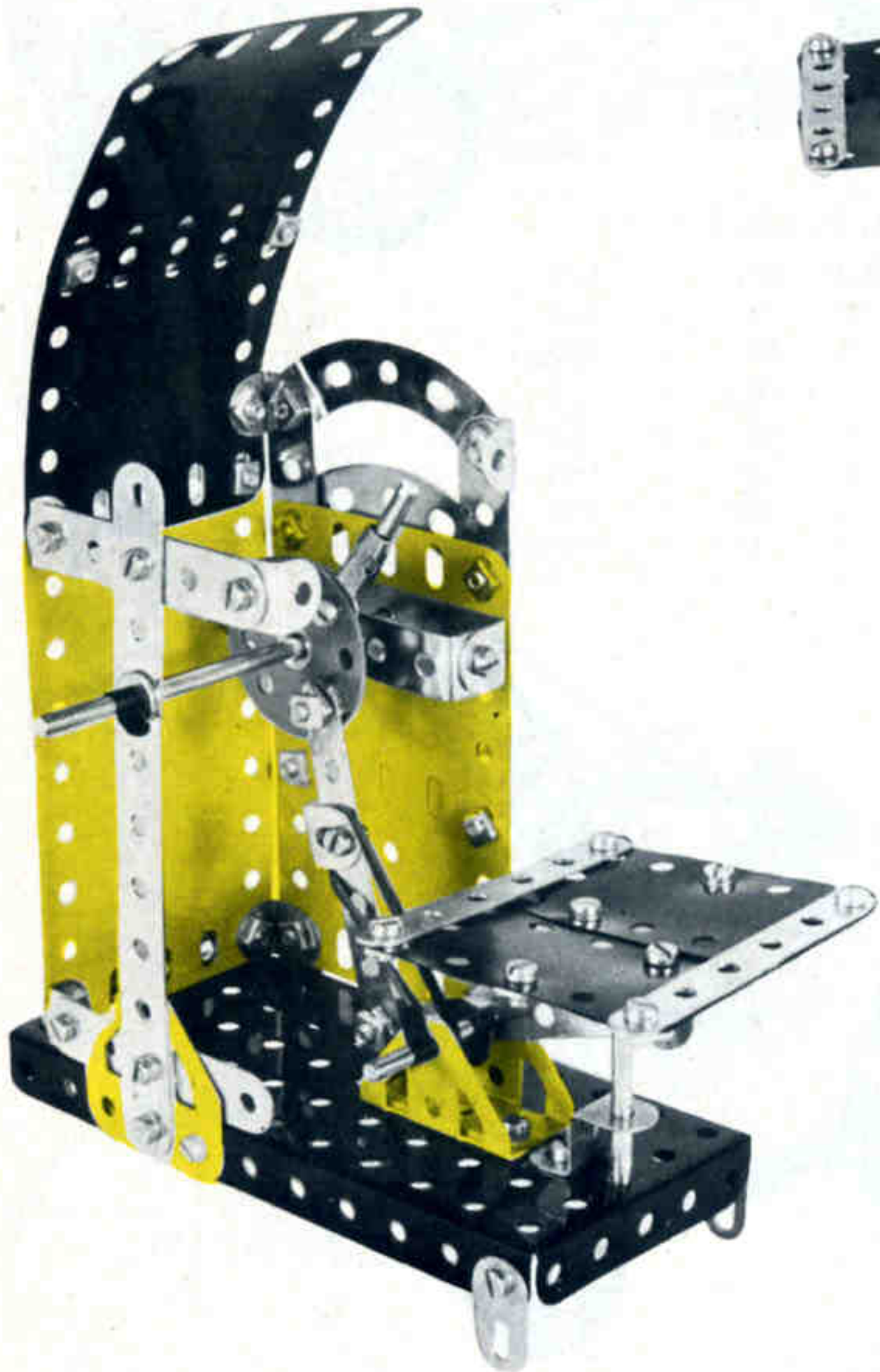

| BALANZA AUTOMATICA 3/179 |          |          |          |
|--------------------------|----------|----------|----------|
| 3 - 2                    | 1 - 20a  | 1 - 52   | 2 - 188  |
| 6 - 5                    | 1 - 24   | 2 - 90a  | 2 - 190  |
| 3 - 10                   | 5 - 35   | 4 - 111c | 1 - 191  |
| 7 - 12                   | 56 - 37a | 1 - 125  | 2 - 194  |
| 1 - 16                   | 47 - 37b | 2 - 126  | 2 - 194a |
| 2 - 17                   | 8 - 38   | 2 - 126a | 1 - 212  |
| 1 - 18b                  | 2 - 48a  | 1 - 186  | 4 - 235a |

179

Automatic scale  
 Balance automatique  
 Bilancia automatica  
 Automatische Waage  
 Balança automática

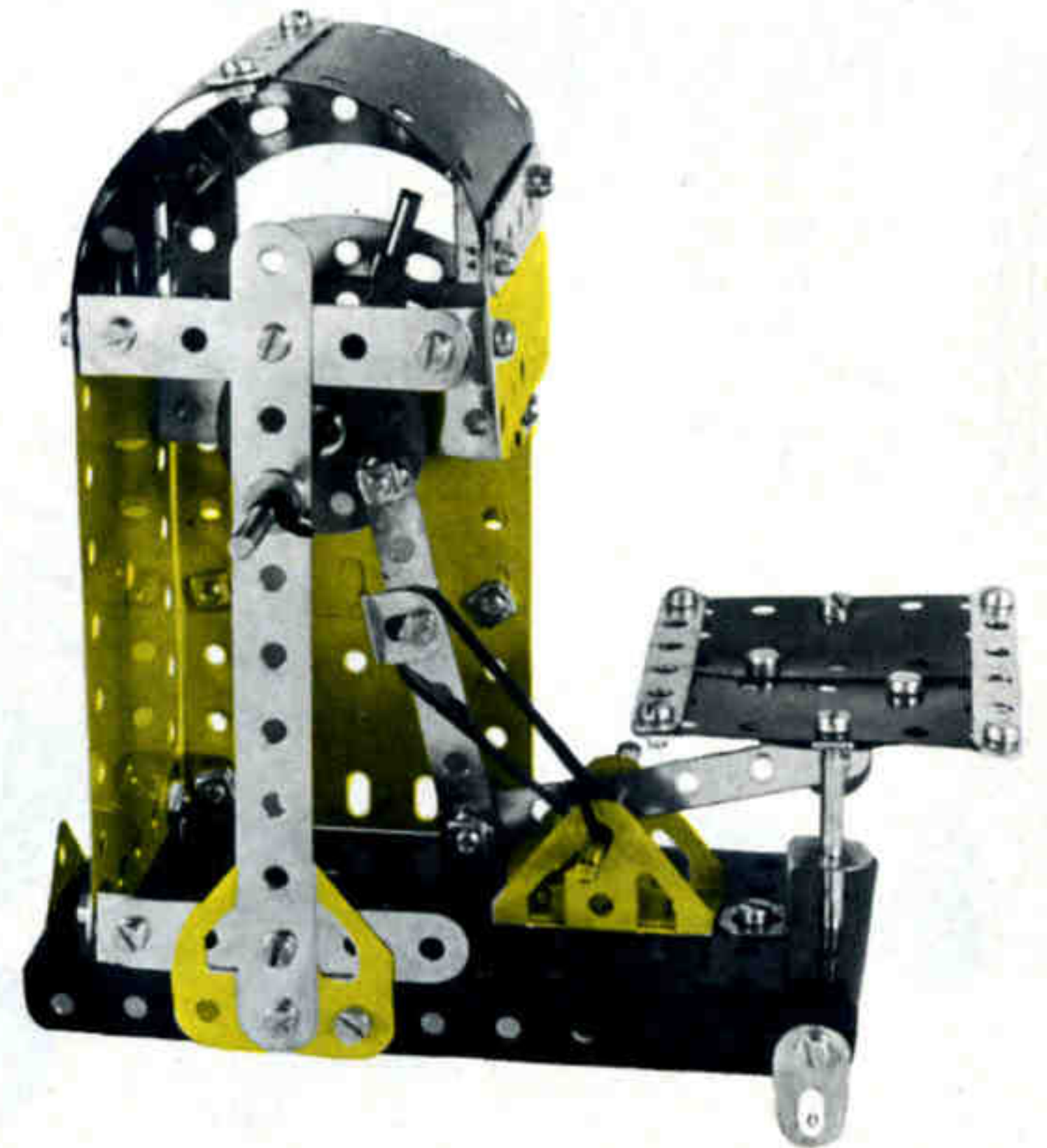



180  
Rotating crane  
Grue tournante  
Gru girevole  
Drehkran  
Guindaste giratório

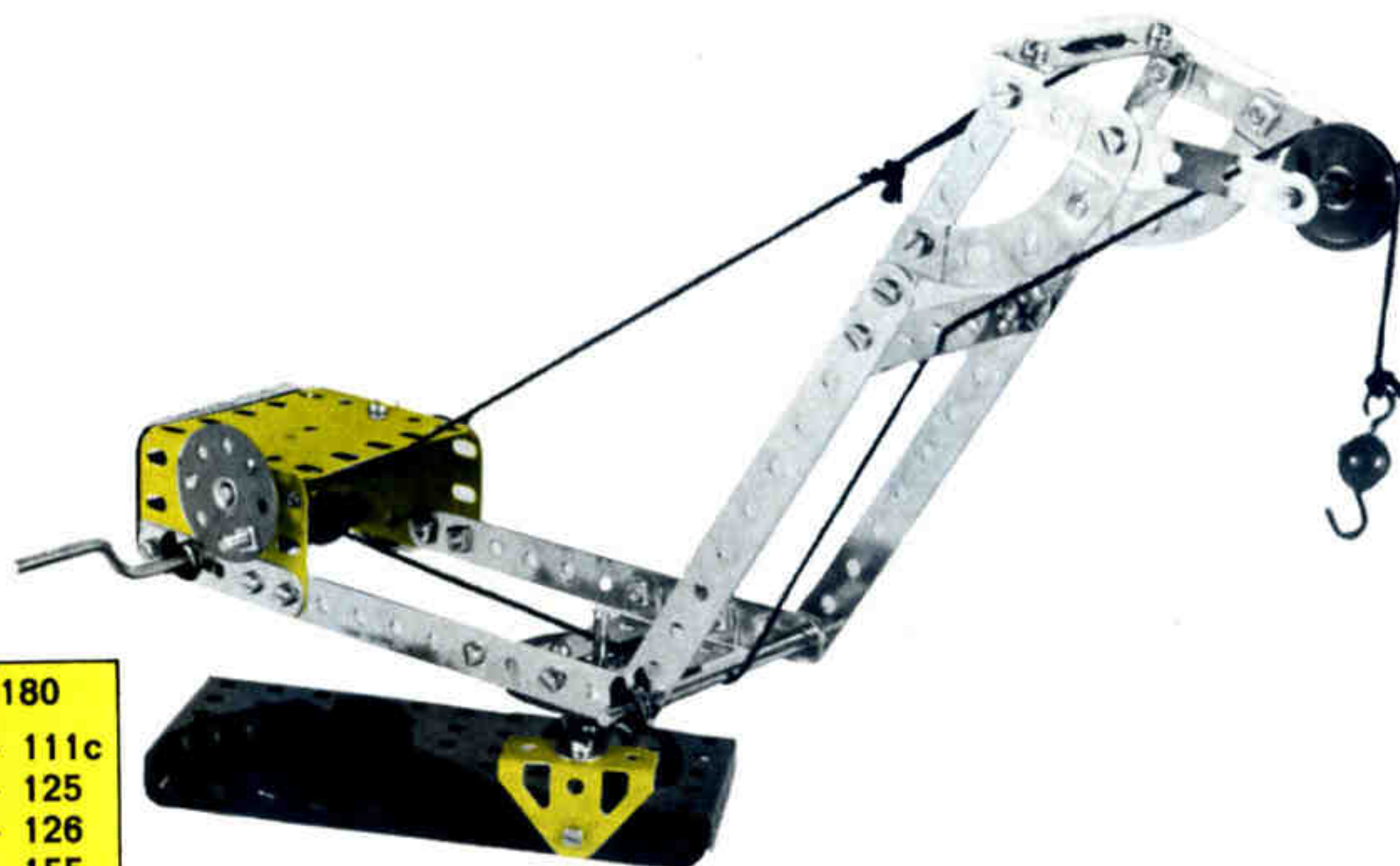

| GRUA GIRATORIA 3/180 |          |          |
|----------------------|----------|----------|
| 4 - 2                | 3 - 22   | 4 - 111c |
| 6 - 5                | 1 - 24   | 1 - 125  |
| 8 - 12               | 6 - 35   | 2 - 126  |
| 2 - 16               | 38 - 37a | 1 - 155  |
| 2 - 17               | 34 - 37b | 2 - 188  |
| 1 - 19s              | 7 - 38   | 1 - 190  |
| 2 - 48a              | 1 - 40   | 1 - 194  |
| 1 - 52               | 1 - 57c  | 4 - 235a |
| 1 - 20a              | 2 - 90a  |          |

182  
Wheat cutting machine  
Batteuse  
Trebbiatrice  
Dreschmaschine  
Debulhadora

| TRILLADORA 3/182 |          |          |          |
|------------------|----------|----------|----------|
| 4 - 2            | 2 - 22   | 50 - 37b | 2 - 142c |
| 6 - 5            | 1 - 22a  | 5 - 38   | 1 - 155  |
| 4 - 10           | 1 - 24   | 2 - 48a  | 2 - 189  |
| 1 - 11           | 2 - 34   | 1 - 52   | 2 - 190  |
| 8 - 12           | 2 - 35   | 2 - 111c | 1 - 191  |
| 2 - 16           | 1 - 36   | 1 - 125  | 1 - 199  |
| 1 - 17           | 52 - 37a | 2 - 126  | 4 - 235a |
| 1 - 20           |          |          |          |



181  
Small truck  
Camionnette  
Camioncino  
Kleinlastwagen  
Camioneta

| CAMIONETA 3/181 |          |          |
|-----------------|----------|----------|
| 4 - 5           | 48 - 37a | 4 - 142c |
| 8 - 12          | 44 - 37b | 2 - 188  |
| 2 - 16          | 5 - 38   | 2 - 189  |
| 1 - 18b         | 2 - 48a  | 2 - 190  |
| 3 - 22          | 1 - 52   | 1 - 191  |
| 2 - 22a         | 2 - 111c | 2 - 194  |
| 1 - 24          | 1 - 125  | 1 - 199  |
| 1 - 35          | 2 - 126a | 1 - 212  |

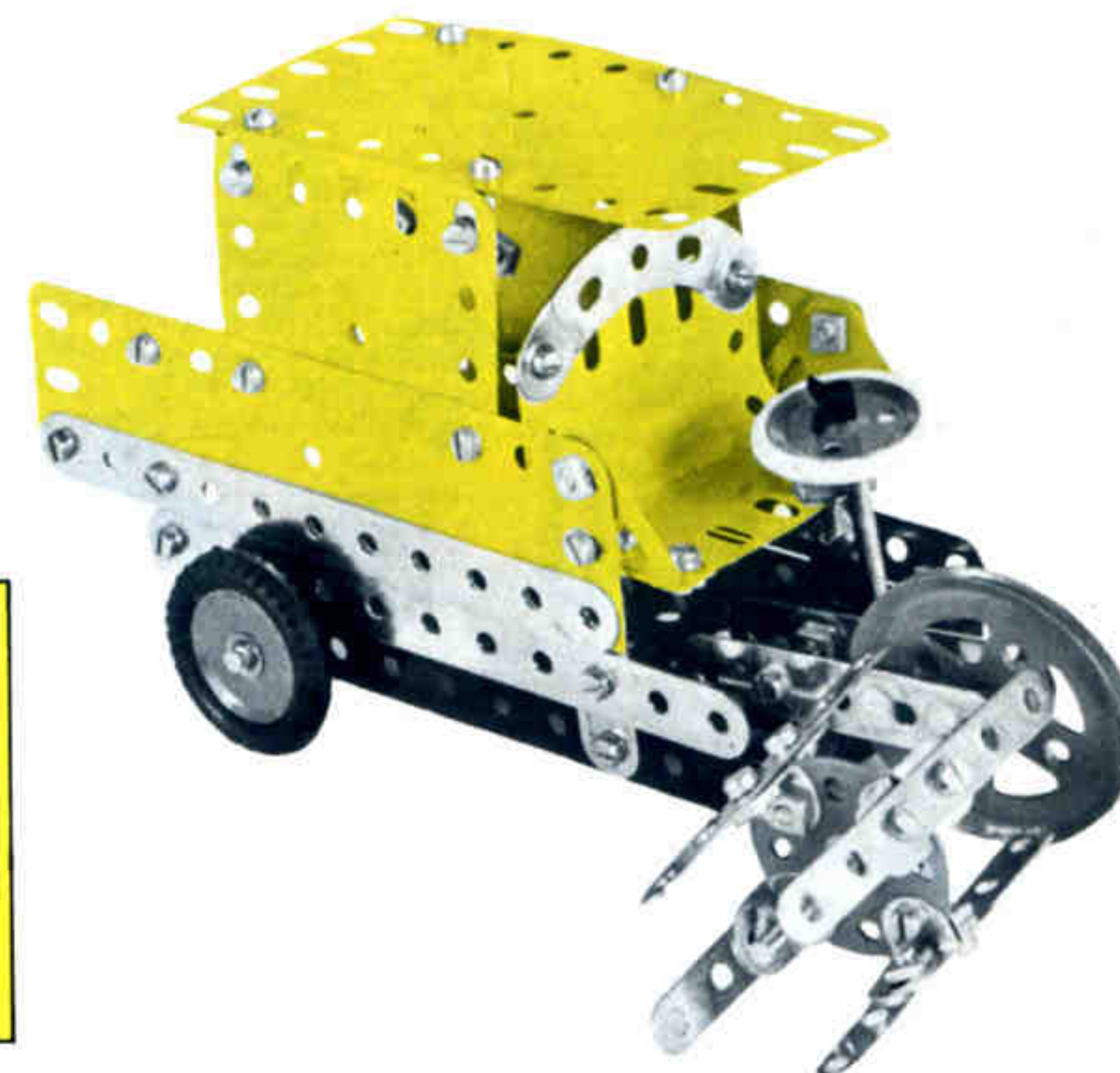

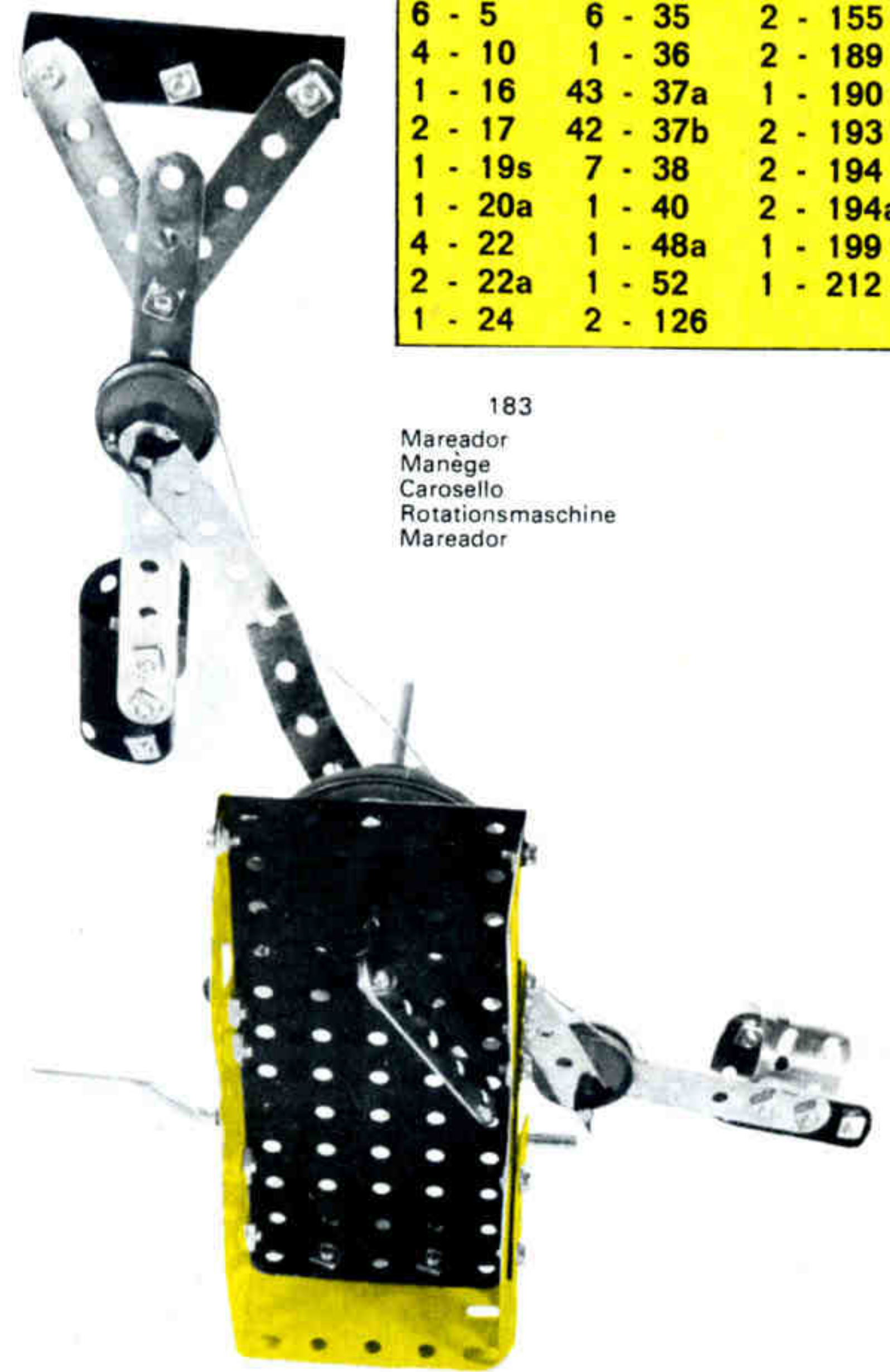
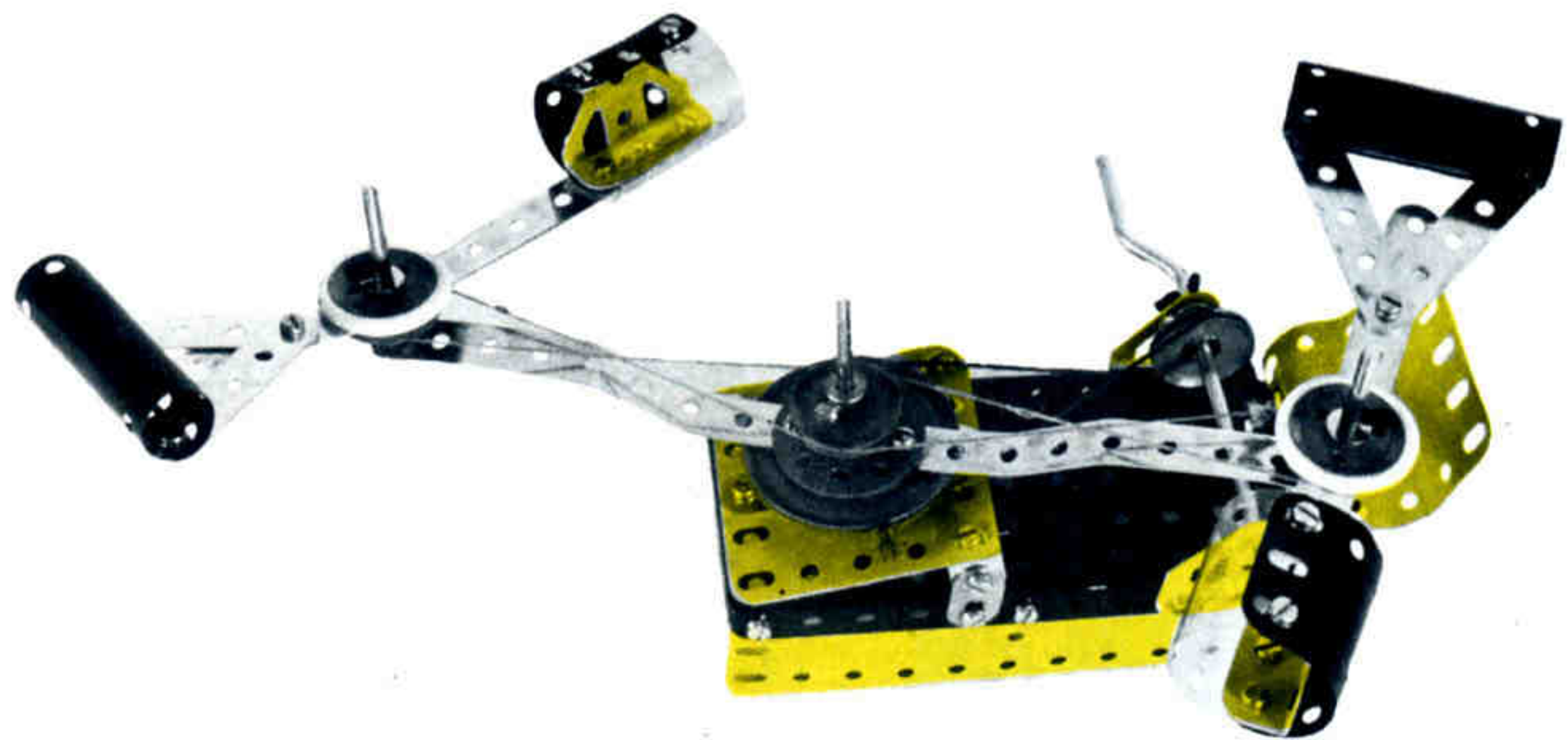

| MAREADOR 3/183 |          |          |
|----------------|----------|----------|
| 4 - 2          | 2 - 34   | 2 - 126a |
| 6 - 5          | 6 - 35   | 2 - 155  |
| 4 - 10         | 1 - 36   | 2 - 189  |
| 1 - 16         | 43 - 37a | 1 - 190  |
| 2 - 17         | 42 - 37b | 2 - 193  |
| 1 - 19s        | 7 - 38   | 2 - 194  |
| 1 - 20a        | 1 - 40   | 2 - 194a |
| 4 - 22         | 1 - 48a  | 1 - 199  |
| 2 - 22a        | 1 - 52   | 1 - 212  |
| 1 - 24         | 2 - 126  |          |

183  
 Mareador  
 Manège  
 Carosello  
 Rotationsmaschine  
 Mareador

LA CUERDA EMPLEADA DEBE SER MUY DELGADA. FUNCIONA PERFECTAMENTE RODANDO LA MANIVELA EN EL SENTIDO DE LAS AGUJAS DEL RELOJ.



RUEDA CADENA PLÁSTICO

91 - 20 dientes  
92 - 10 dientes

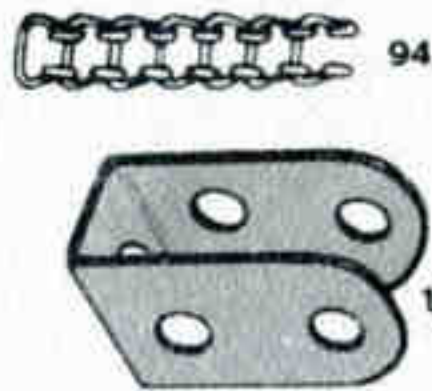

94 Cadena metálica  
101 Lizo para telar  
102 Tira doble ángulo



RUEDAS CADENA METALICA

95 - 50 mm, 36 dientes  
95 a - 38 mm, 28 dientes  
96 - 25 mm, 18 dientes  
96 a - 19 mm, 14 dientes

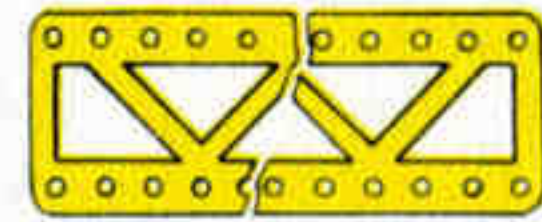

VIGUETA CALADA

97 - 7 aguj. 9 cm.  
98 - 5 aguj. 6 cm.  
99 b - 15 aguj. 19 cm.  
99 - 25 aguj. 32 cm.  
99 a - 19 aguj. 24 cm.  
100 - 11 aguj. 14 cm.  
100 a - 9 aguj. 11,5 cm.

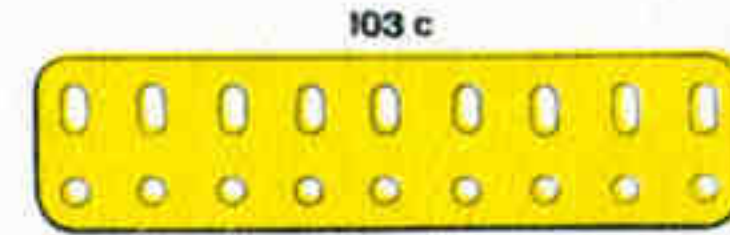

VIGUETA PLANA

103 - 11 aguj. 14 cm.  
103 a - 19 aguj. 24 cm.  
103 b - 25 aguj. 32 cm.  
103 c - 9 aguj. 11,5 cm.  
103 d - 7 aguj. 9 cm.  
103 e - 6 aguj. 7,5 cm.  
103 f - 5 aguj. 6 cm.  
103 g - 4 aguj. 5 cm.  
103 h - 3 aguj. 4 cm.  
103 k - 15 aguj. 19 cm.

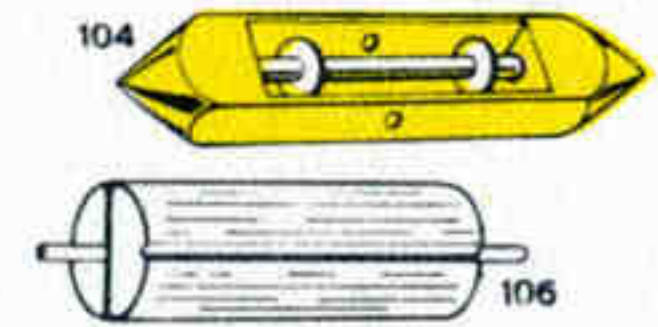

104 - Lanzadera para telar  
105 a - Pua peine  
106 - Rodillo telar  
106 a - Rodillo arena telar  
107 - Mesa para máquina tejedora

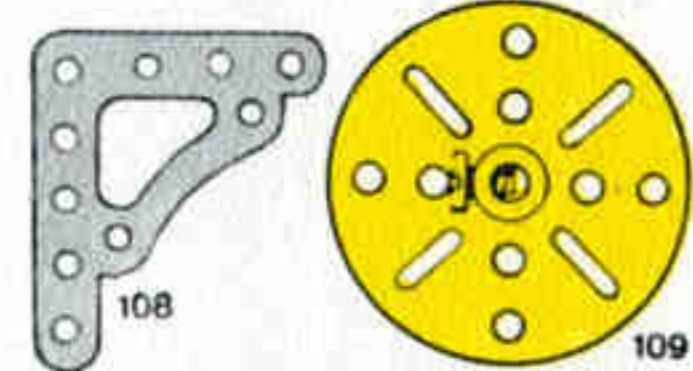

108 Arquitrabe (escuadra)  
109 Placa frontal 6 cm. Ø

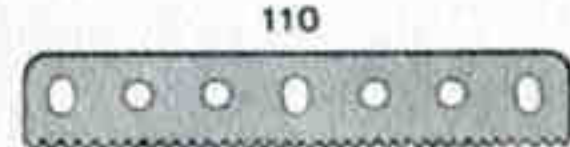

110 - Barra cremallera



TORNILLOS LARGOS

111 - 19 mm.  
111 a - 12 mm.  
111 c - 9,5 mm.  
111 d - 28 mm.



115 - Clavija roscada 15 mm.  
115 a - Clavija roscada 35 mm.



116 - Estribo de conexión  
116 a - Estribo articulado



118 - Disco cubo 14 cm. Ø

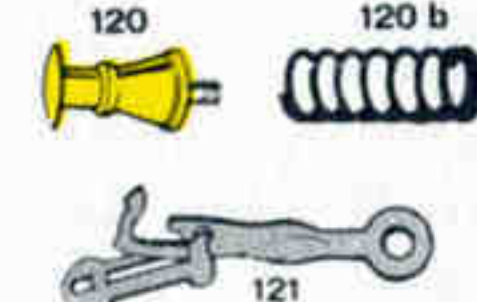

120 - Tope  
120 b - Resorte de compresión  
121 - Enganche para trenes



124 - Soporte angular inverso 2 aguj.  
125 - Soporte angular inverso 1 aguj.

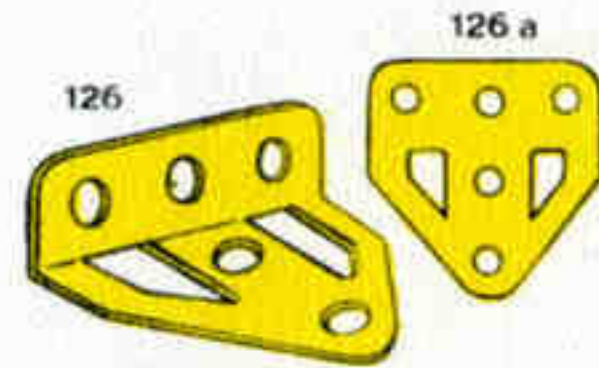

126 - Muñón  
126 a - Muñón plano

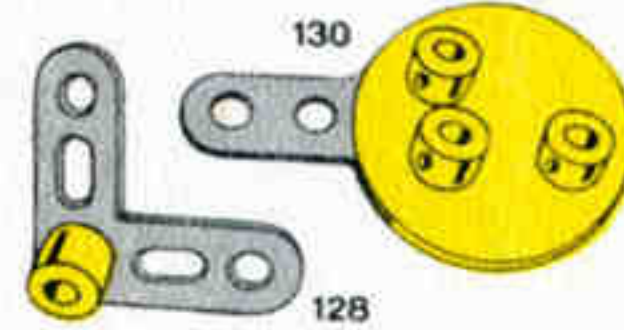

128 - Palanca angular con buje  
130 - Excéntrica 3 movimientos

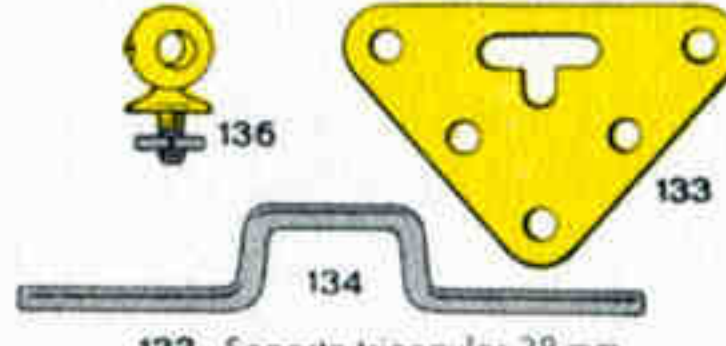

133 - Soporte triangular 38 mm.  
134 - Eje cigüeña 25 mm. de curva  
136 - Apoyo balastrada



137 - Reborde de ruedas  
138 - Chimenea de vapor

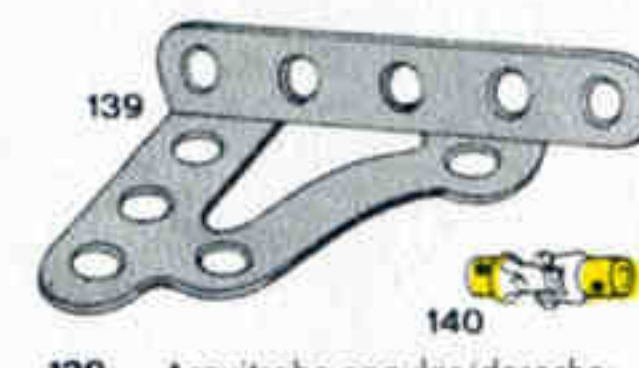

139 - Arquitrabe angular (derecho)  
139 a - Arquitrabe angular (izquierdo)  
140 - Acoplamiento universal



142 - Neumático 75 mm. Ø  
142 a - Neumático 50 mm. Ø  
142 c - Neumático 25 mm. Ø



143 - Vigueta circular 140 mm. Ø  
144 - Enchufe para embrague

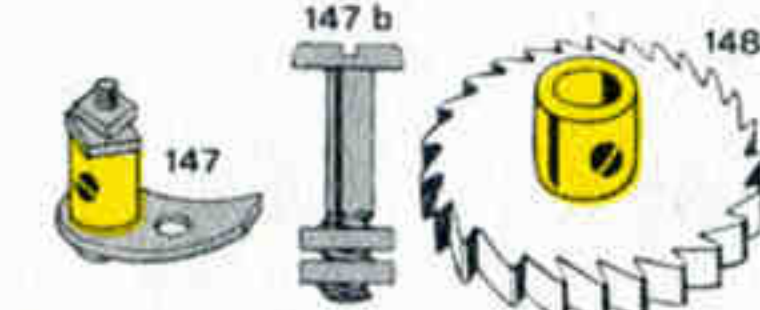

147 - Trinquete completo  
147 a - Trinquete con buje  
147 b - Tornillo con dos tuercas  
148 - Rueda de trinquete

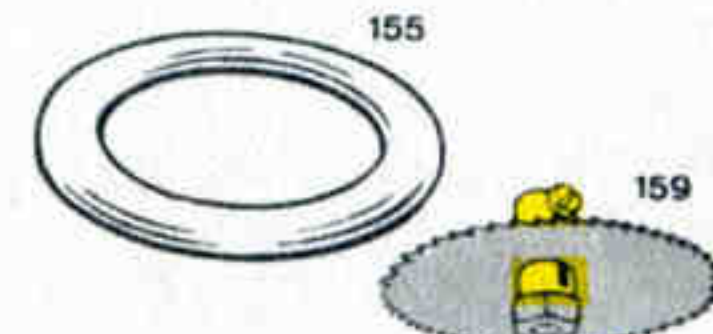

155 - Anillo 25 mm. Ø  
155 a - Anillo 15 mm. Ø  
159 - Sierra circular

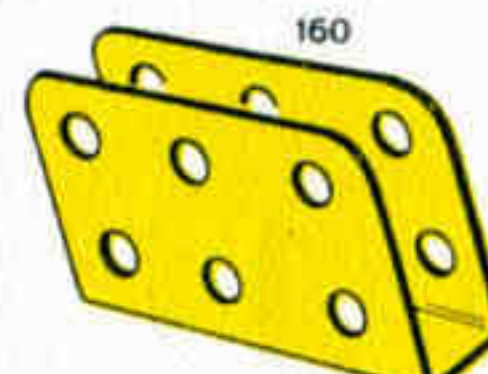

160 - Soporte en U 3x2x1 aguj.

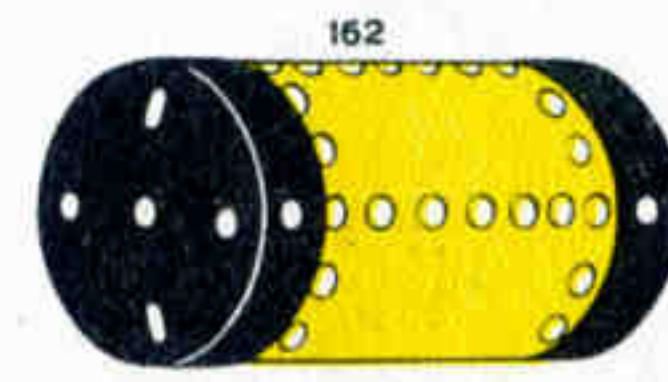

162 - Caldera con tapas 12'5x5 cm.  
162 a - Tapa caldera  
162 b - Caldera sin tapas

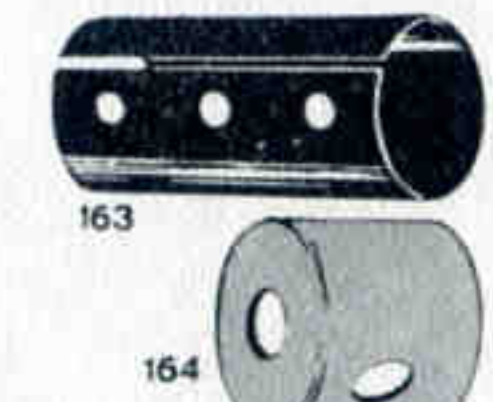

163 - Cilindro abierto  
164 - Enchufe para cilindro



165 - Acoplamiento torniquete  
166 - Soporte frontal

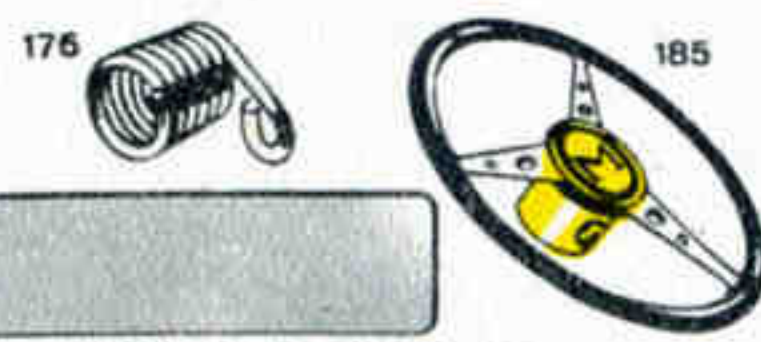

176 - Muelle péndulo reloj  
185 - Rueda manda 45 mm. diam.



186 - Carr. imp. 6 cm.  
186 a - Carr. imp. 14 cm.  
186 b - Carr. imp. 24 cm.  
187 - Rueda auto 6 cm. Ø

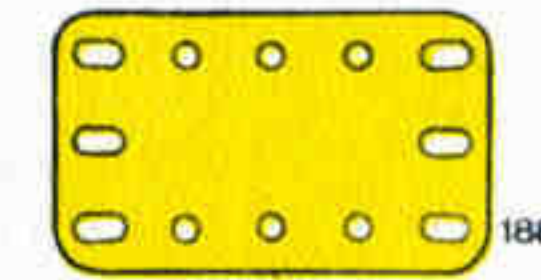

PLACA FLEXIBLE

188 - (acero) 3 x 5 aguj. 6 x 4 cm.  
189 - (acero) 3 x 11 aguj. 14 x 4 cm.  
190 - (acero) 5 x 5 aguj. 6 x 6 cm.  
190 a - (acero) 5 x 7 aguj. 9 x 6 cm.  
191 - (acero) 5 x 9 aguj. 11,5 x 6 cm.  
192 - (acero) 5 x 11 aguj. 14 x 6 cm.

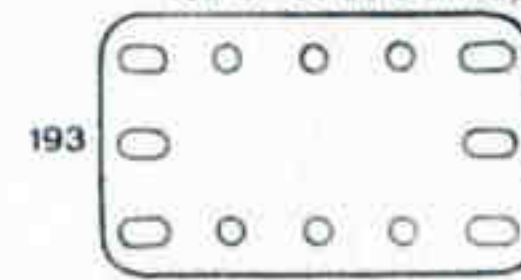

PLACA FLEXIBLE

193 - (trans.) 3 x 5 aguj. 6 x 4 cm.  
193 a - (trans.) 5 x 5 aguj. 6 x 6 cm.  
193 b - (trans.) 5 x 7 aguj. 9 x 6 cm.  
193 c - (trans.) 5 x 9 aguj. 11,5 x 6 cm.  
193 d - (trans.) 3 x 11 aguj. 14 x 4 cm.  
193 e - (trans.) 5 x 11 aguj. 14 x 6 cm.



PLACA FLEXIBLE

194 - (plás. negro) 3 x 5 aguj. 6 x 4 cm.  
194 a - (plás. negro) 5 x 5 aguj. 6 x 6 cm.  
194 b - (plás. negro) 5 x 7 aguj. 9 x 6 cm.  
194 c - (plás. negro) 5 x 9 aguj. 11,5 x 6 cm.  
194 d - (plás. negro) 3 x 11 aguj. 14 x 4 cm.  
194 e - (plás. negro) 5 x 11 aguj. 14 x 6 cm.

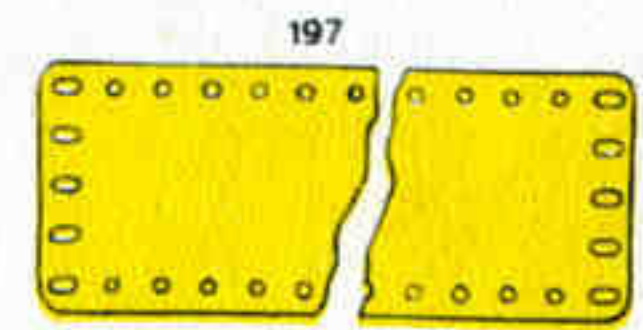

195 - Placa univ. 15x5 aguj. 19x6 cm.  
196 - Placa univ. 19x5 aguj. 24x6 cm.  
197 - Placa univ. 25x5 aguj. 32x6 cm.

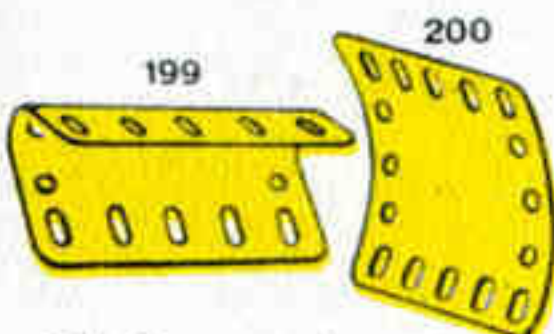

199 - Placa curvada en U  
200 - Placa curvada 5x5 agujeros



212 - Conexión varilla y tira  
212 a - Conexión varilla y tira (áng.)  
213 - Conexión varillas

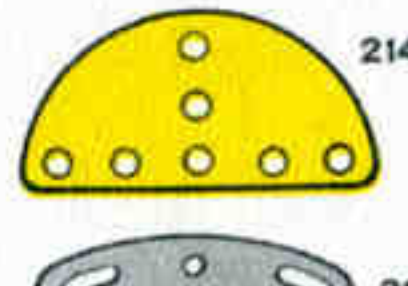

214 - Placa semicircular  
215 - Tira curva 75 mm. con muesca

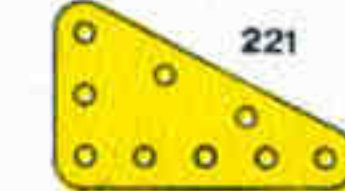

221 - Triáng. acero flex. 5x3 aguj.  
222 - Triáng. acero flex. 5x4 aguj.  
223 - Triáng. acero flex. 5x5 aguj.  
224 - Triáng. acero flex. 7x3 aguj.  
225 - Triáng. acero flex. 7x4 aguj.

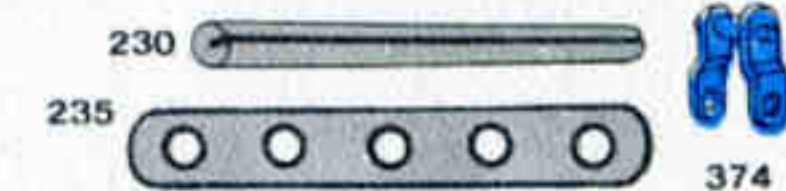

230 - Varilla acanalada  
231 - Perno para varilla acanalada  
235 - Tira perforada estrecha, 5 aguj. 63x9 mm.  
235 a - Tira perforada estrecha, 6 aguj. 75x9 mm.  
235 b - Tira perforada estrecha, 7 aguj. 88x9 mm.  
374 - Malla cadena de plástico



Con su catálogo,  
construirás **183** modelos  
¡Tú inventarás muchos  
más!



Com o seu catálogo,  
construirás **183**  
modelos.  
Tu inventarás ainda  
muitos mais!

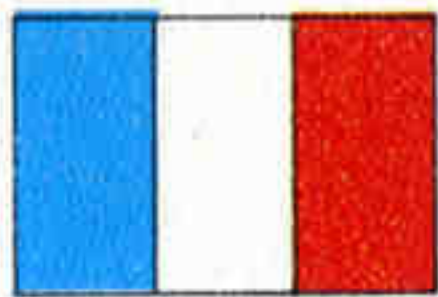

Avec son catalogue,  
tu construiras **183**  
modèles.  
Tu en inventeras bien  
d'autres encore!



With its catalogue  
you will  
make **183** models.  
You will invent  
many more  
of your own!

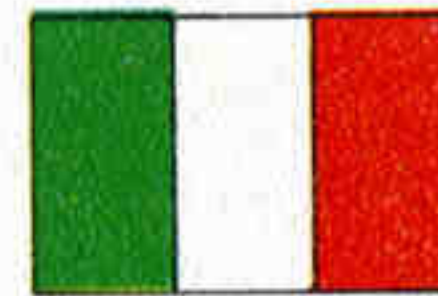

Con il suo catalogo  
ne costruirai **183**  
modelli,  
¡Tu ne inventerai  
molti di più!



Mit seinem Katalog  
kannst Du **183**  
Modelle erbauen;  
Du kannst noch  
viele hinzuerfinden!

MEDIO SIGLO DE EXPERIENCIA EN LA FABRICACION DE JUGUETES CONSTRUCTIVOS METALICOS



1970 NOVEDADES POCH, S. A. - BARCELONA - SPAIN

**Poch**