

# METALING®

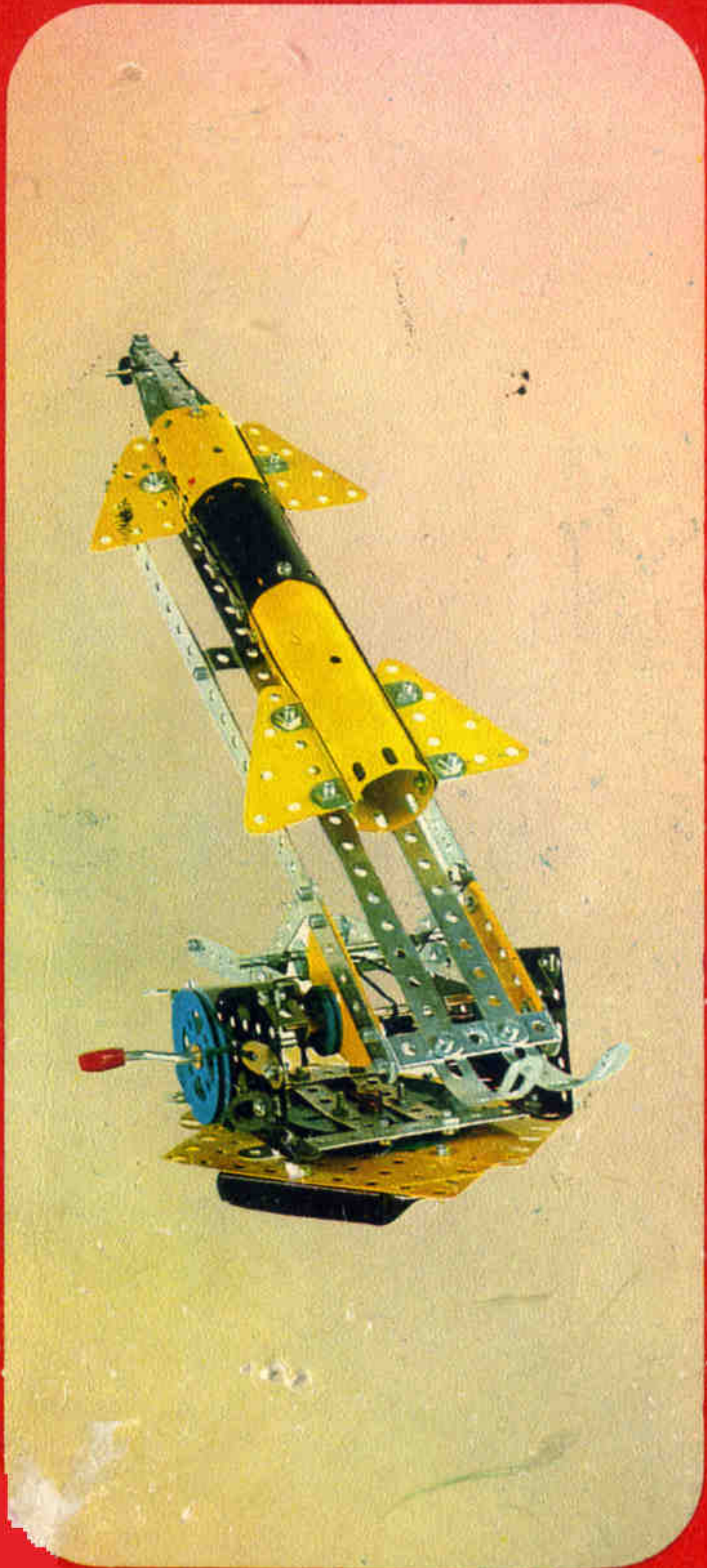

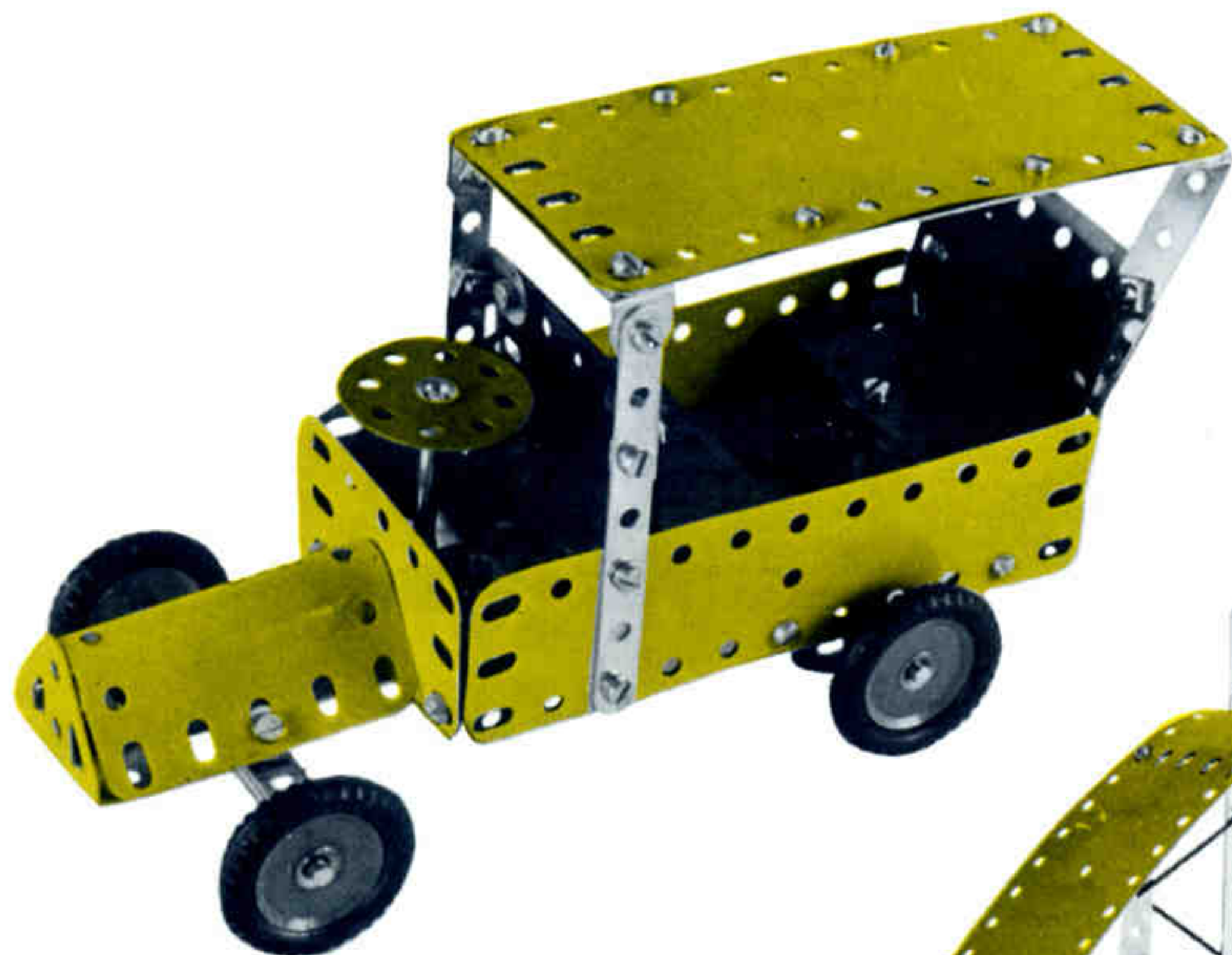



**COCHE ANTIGUO 3/184**

2 - 2	41 - 37b	1 - 190
2 - 5	2 - 38	2 - 189
1 - 11	2 - 48a	1 - 192
4 - 12	1 - 52	2 - 194a
2 - 16	2 - 90a	1 - 199
1 - 17	1 - 125	3 - 235a
4 - 22	1 - 126	1 - 194
2 - 35	4 - 142c	
41 - 37a	1 - 188	

**PUENTE ELEVADIZO 3/186**

5 - 2	4 - 35	1 - 111c
5 - 5	43 - 37a	2 - 189
1 - 11	40 - 37b	1 - 192
7 - 12	4 - 38	4 - 221
1 - 16	1 - 40	4 - 235a
1 - 19g	2 - 48a	3 - 235b
1 - 23	1 - 52	

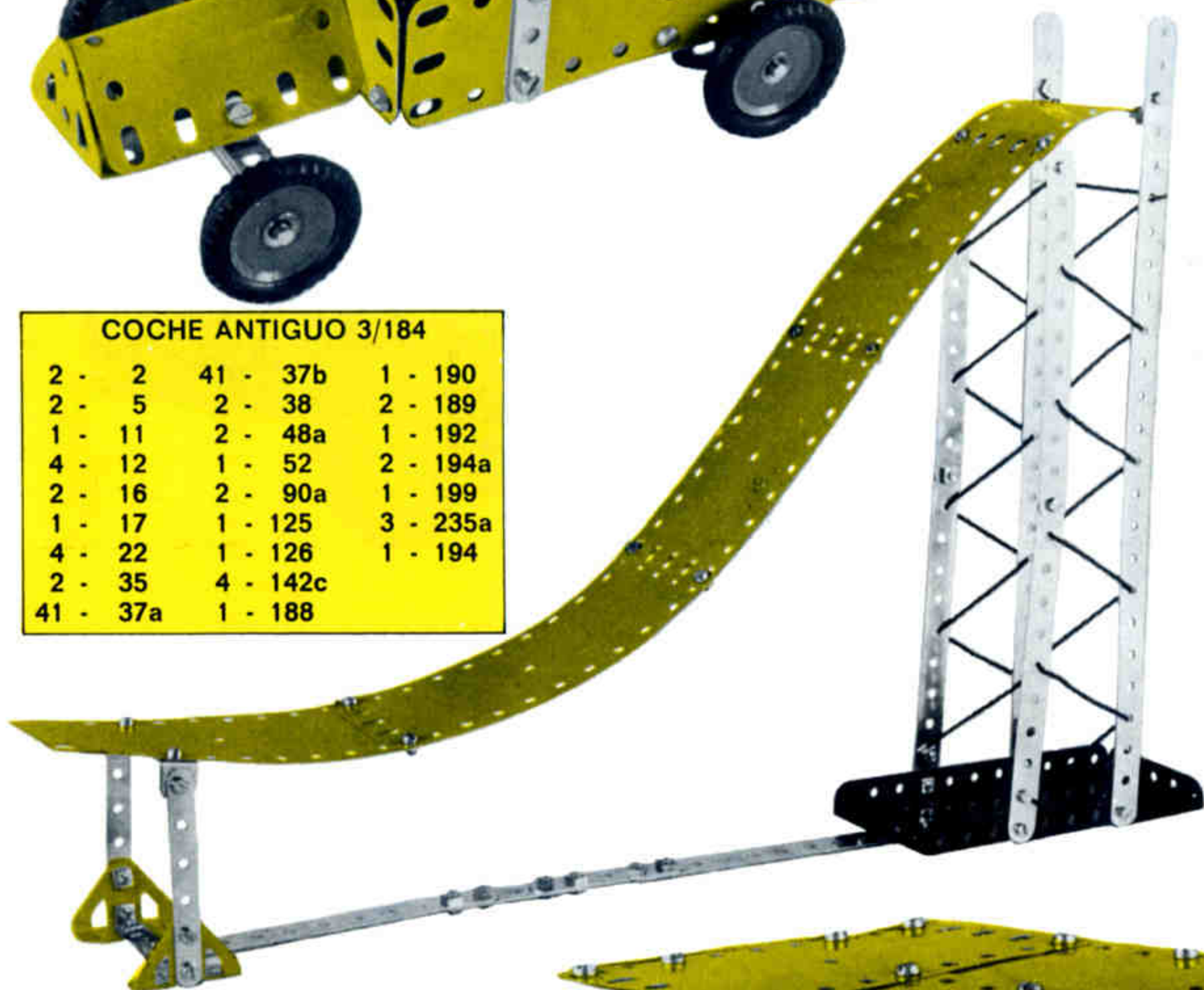
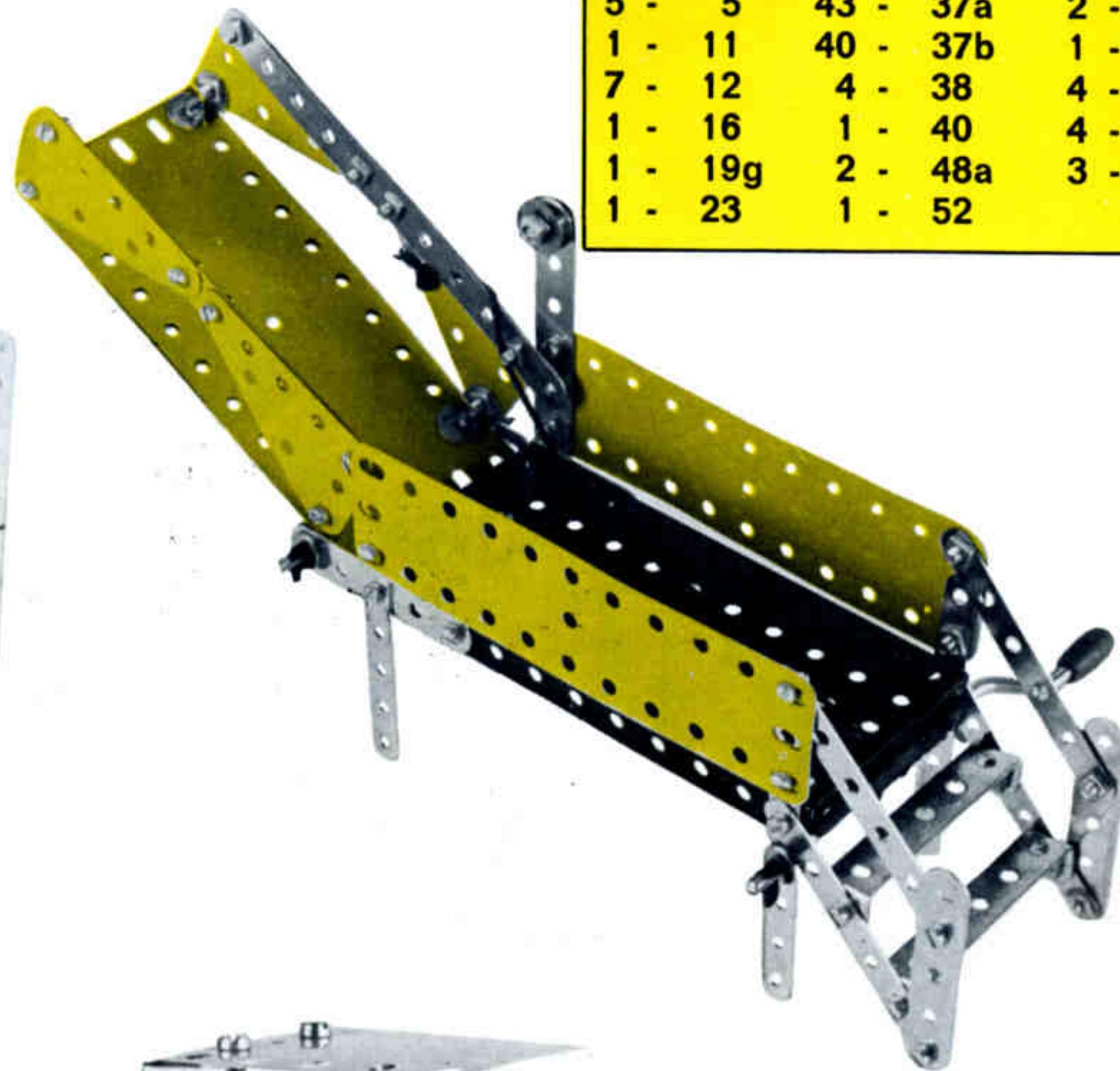

**TRAMPOLIN NIEVE 3/185**

2 - 1	1 - 52
6 - 2	2 - 126
3 - 5	1 - 190
2 - 12	1 - 191
41 - 37a	2 - 192
41 - 37b	2 - 235b
2 - 48a	

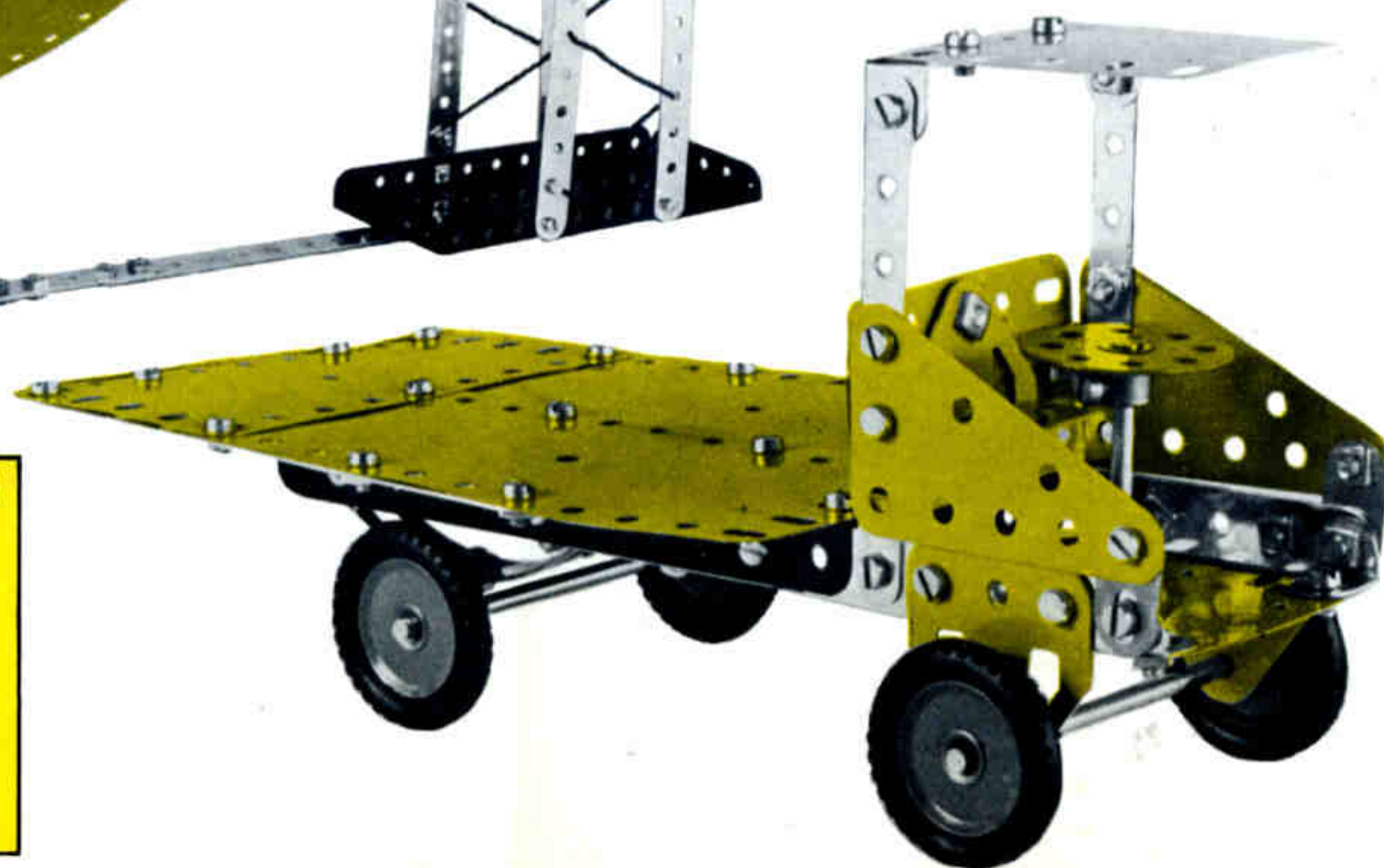

**CAMIONETA ESTACION 3/187**

4 - 2	1 - 52
2 - 10	2 - 126a
9 - 12	4 - 142c
2 - 16	1 - 126
1 - 17	2 - 190
4 - 22	1 - 191
1 - 24	1 - 188
2 - 35	2 - 192
53 - 37a	2 - 215
53 - 37b	2 - 221
2 - 48a	3 - 235a

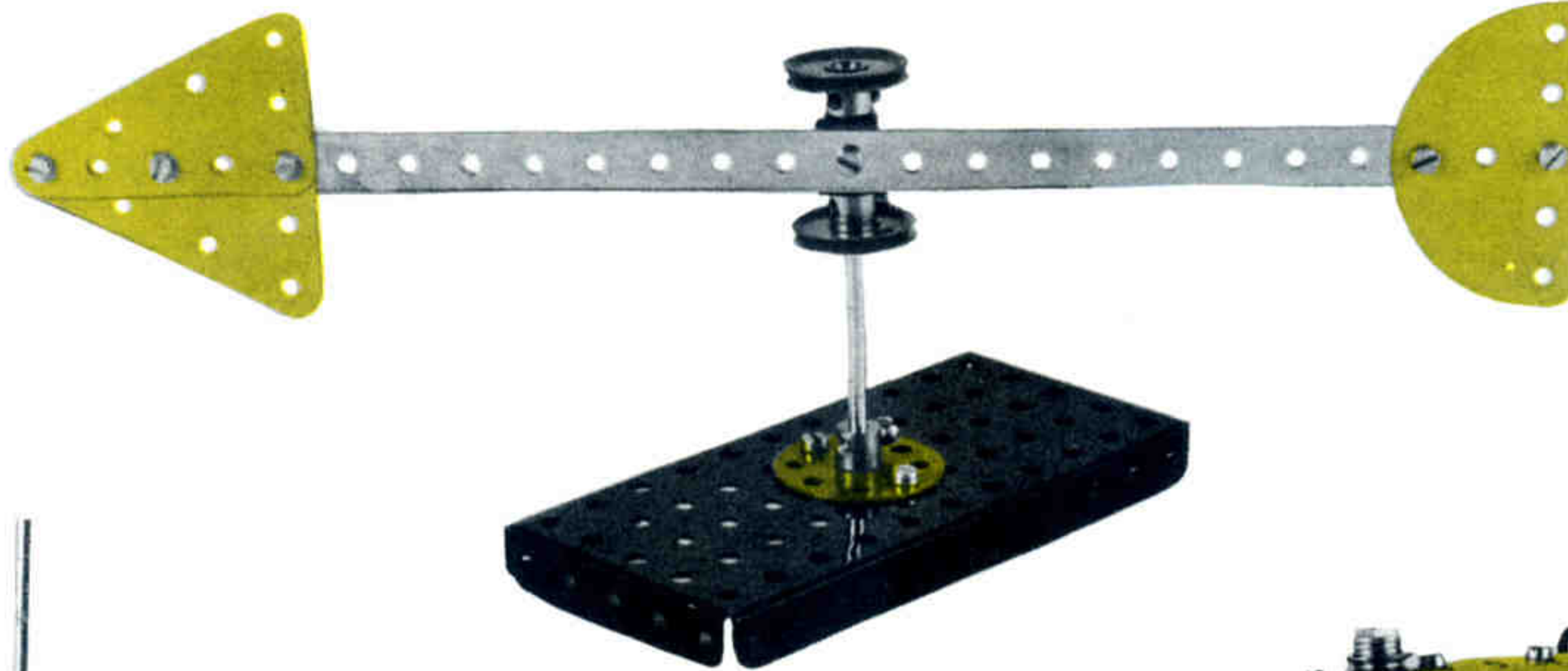

VELETA 3/189			
1 -	1	8 -	37a
1 -	11	8 -	37b
1 -	16	1 -	52
2 -	22	1 -	214
1 -	24	2 -	221

LOCOMOTORA 3/190		
2 -	2	5 - 38
8 -	12	2 - 48a
2 -	16	1 - 52
4 -	22	3 - 111c
2 -	22a	2 - 125
1 -	23	4 - 142c
49 -	37a	2 - 155
46 -	37b	2 - 192
		2 - 190
		2 - 188
		2 - 194
		2 - 194d
		2 - 214
		1 - 235a

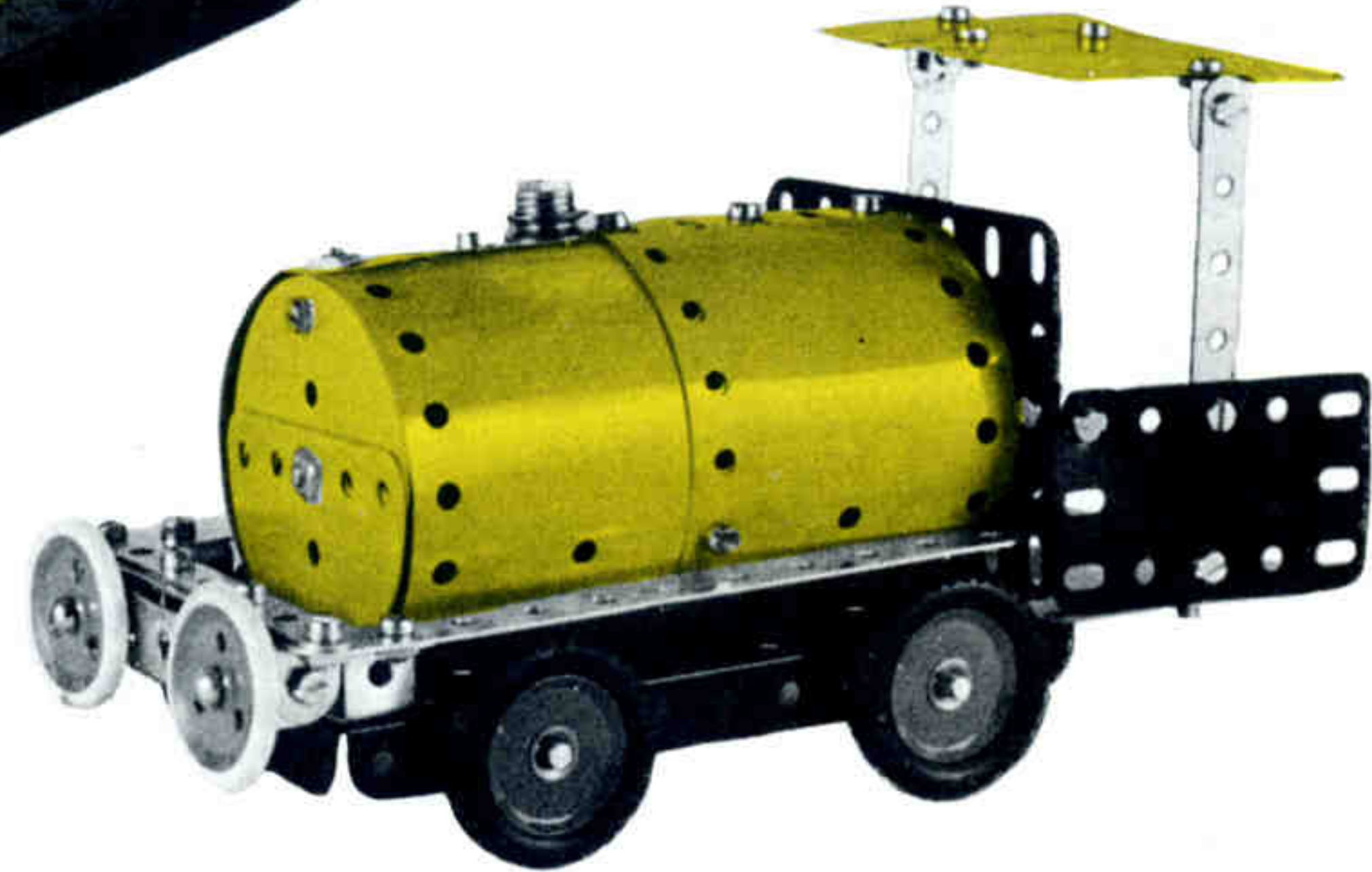

DEPOSITO ELEVADO DE AGUA 3/188	
4 -	2
4 -	5
8 -	12
1 -	16
20 -	37a
20 -	37b
2 -	191
2 -	214
4 -	215
1 -	212

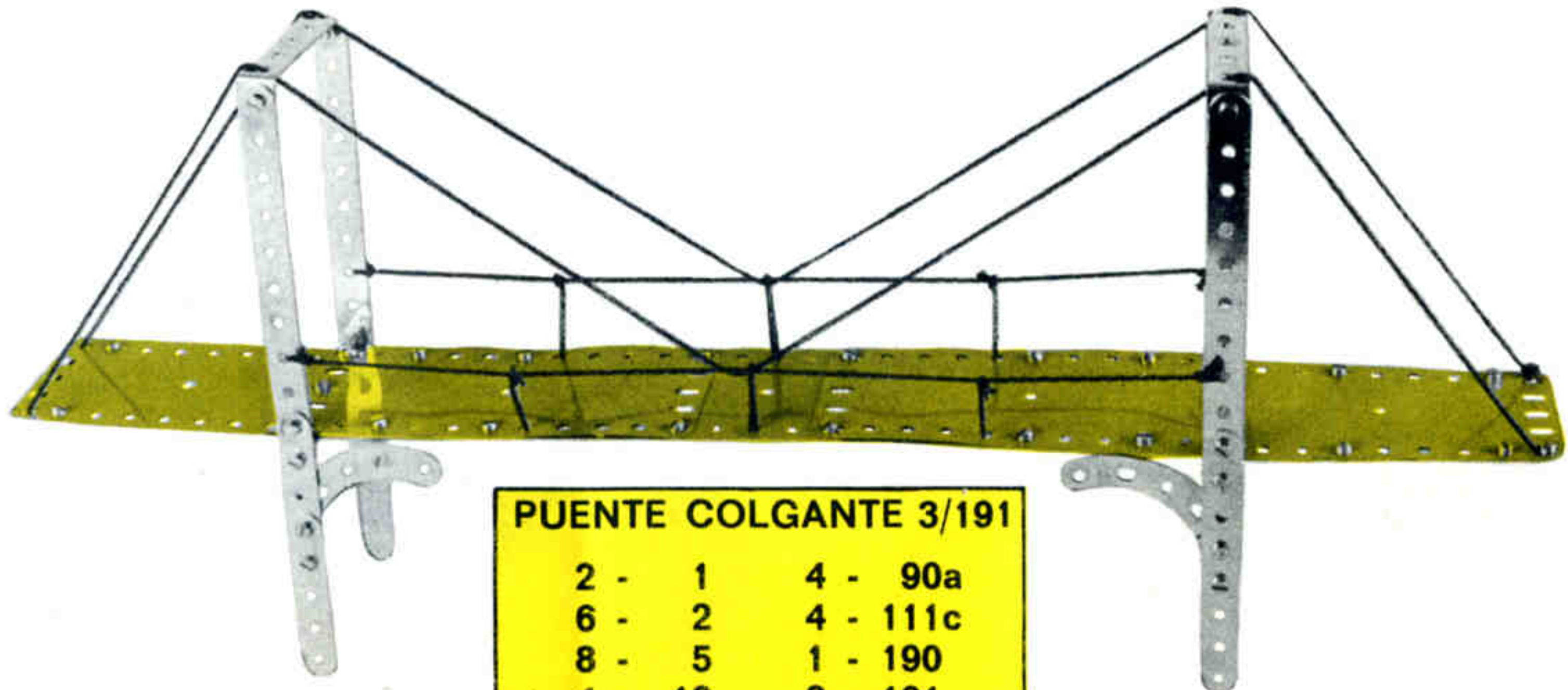

PUENTE COLGANTE 3/191			
2 -	1	4 -	90a
6 -	2	4 -	111c
8 -	5	1 -	190
4 -	12	2 -	191
45 -	37a	2 -	192
41 -	37b	4 -	235a
2 -	48a		

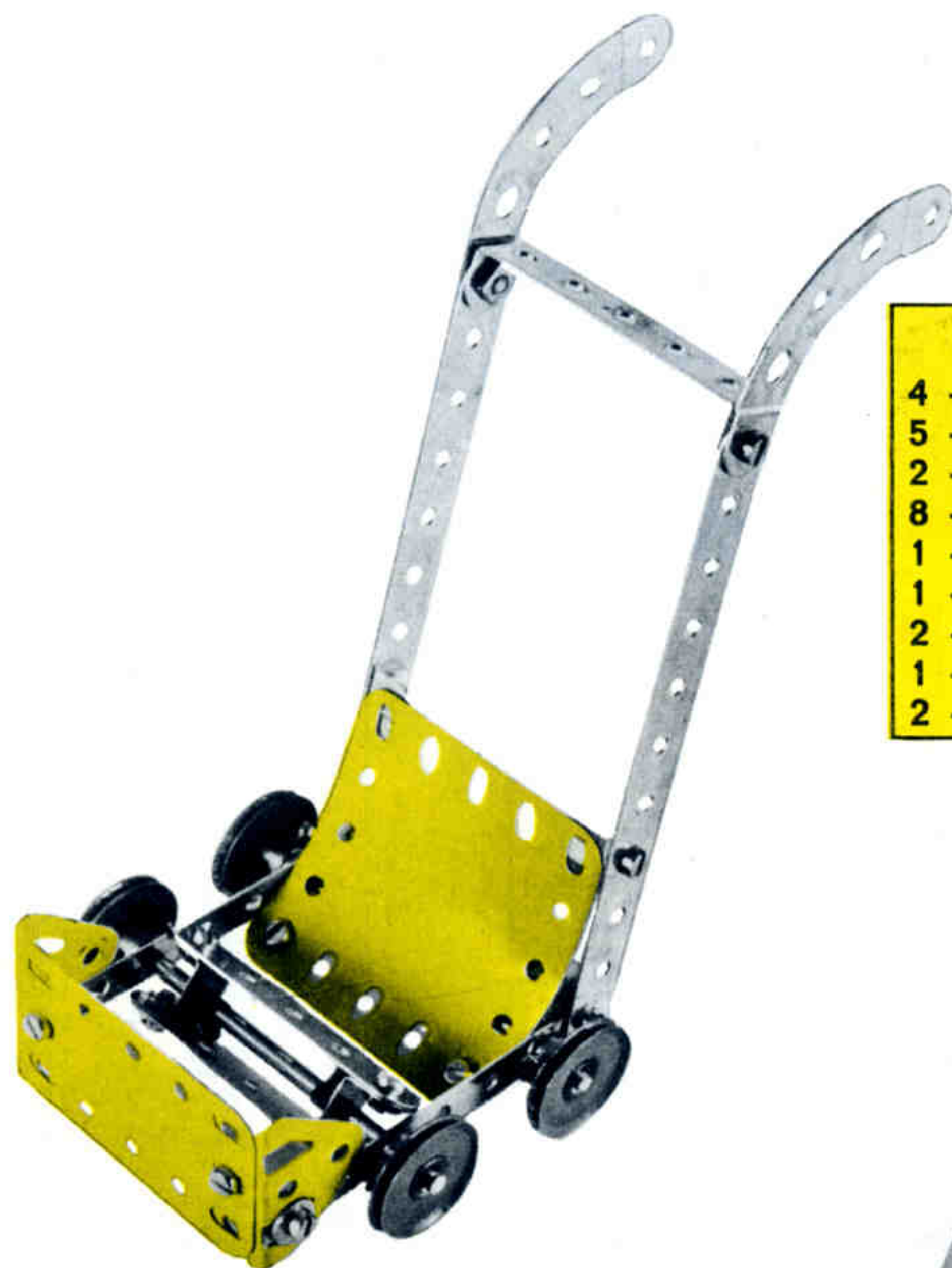

**NAVE ESPACIAL 3/193**

4 - 2	2 - 35	2 - 188
5 - 5	40 - 37a	1 - 189
2 - 11	40 - 37b	2 - 191
8 - 12	2 - 38	1 - 193
1 - 16	1 - 38d	2 - 214
1 - 18a	1 - 52	2 - 215
2 - 22a	2 - 126	2 - 235b
1 - 23	2 - 155	
2 - 24	1 - 176	

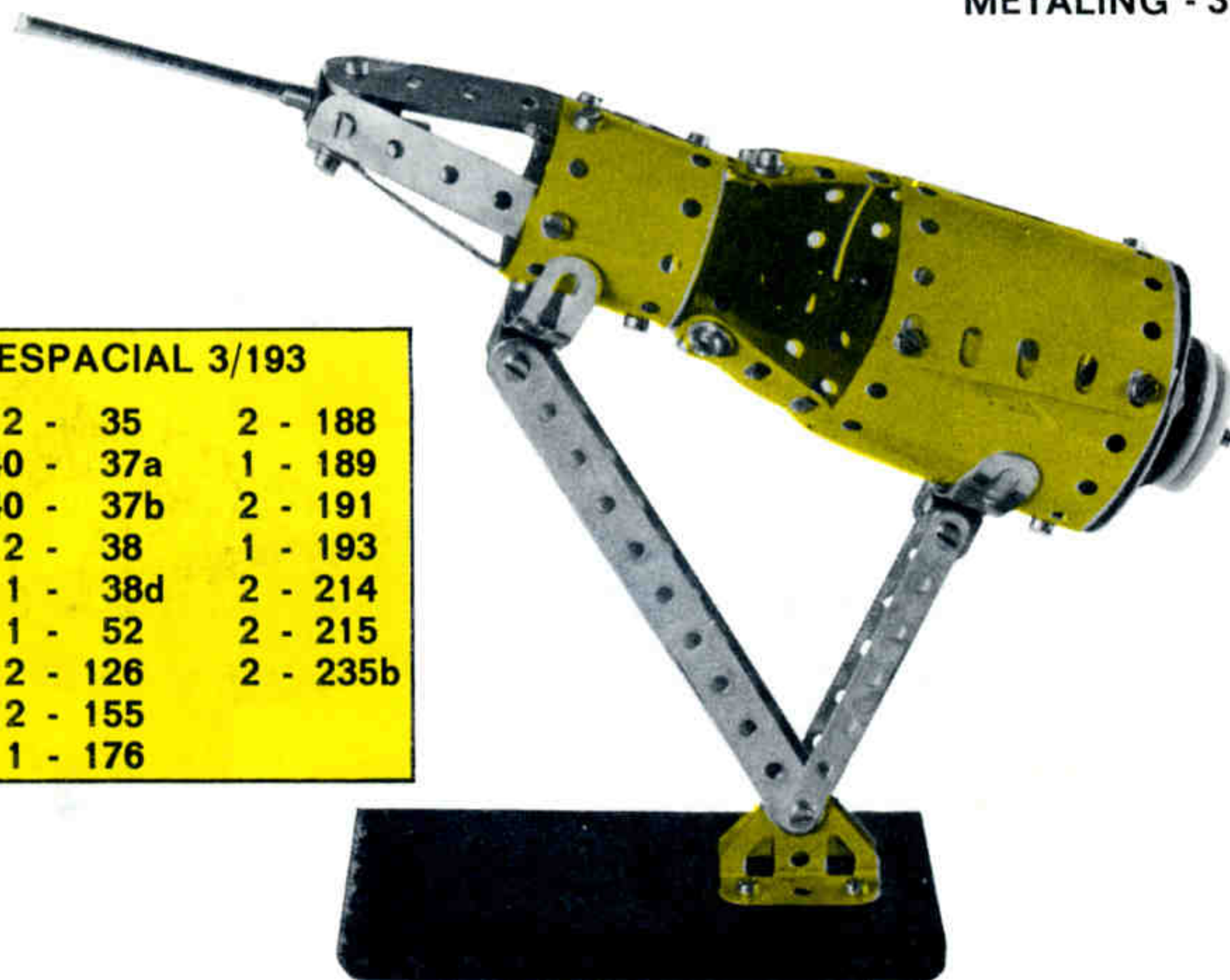

**SEGADORA DE CESPED 3/192**

2 - 2	2 - 35	2 - 126
2 - 5	18 - 37a	2 - 188
2 - 11	18 - 37b	1 - 200
2 - 12	4 - 38	2 - 235b
2 - 16	2 - 48a	
4 - 22	2 - 90a	

**ESPADA 3/195**

1 - 1
3 - 37a
1 - 37b
2 - 38
2 - 111c
2 - 215
4 - 235b

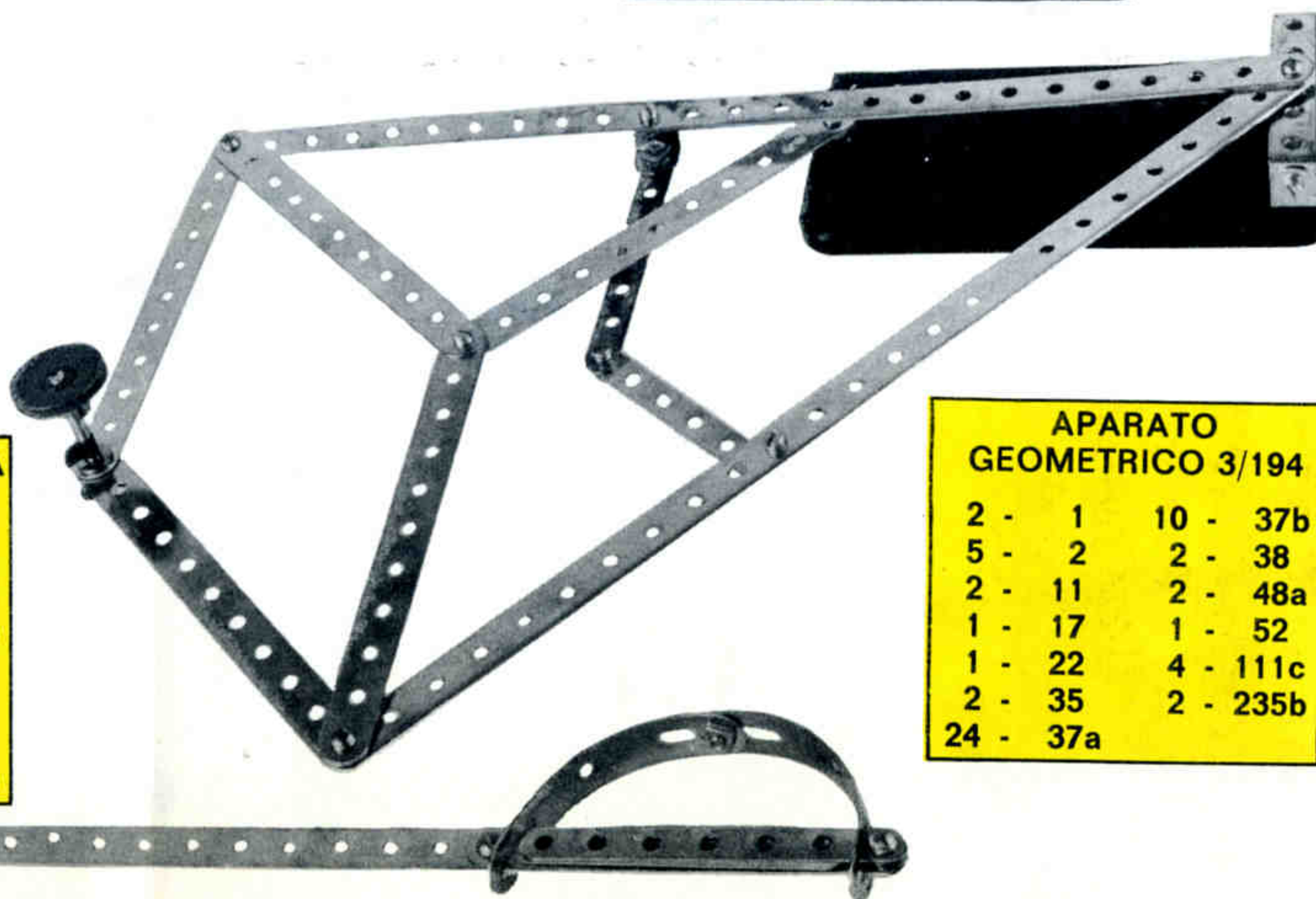

**APARATO GEOMETRICO 3/194**

2 - 1	10 - 37b
5 - 2	2 - 38
2 - 11	2 - 48a
1 - 17	1 - 52
1 - 22	4 - 111c
2 - 35	2 - 235b
24 - 37a	

METALING - 4

BULLDOZER 3/197				
3 - 2	2 - 38a	1 - 190	1 - 213	
1 - 11	1 - 48b	2 - 189	2 - 214	
9 - 12	1 - 52	2 - 191	4 - 215	
1 - 22	4 - 111c	1 - 192	4 - 221	
65 - 37a	2 - 126a	1 - 194a		
61 - 37b	1 - 142c	1 - 193		
10 - 38	2 - 188	1 - 212		

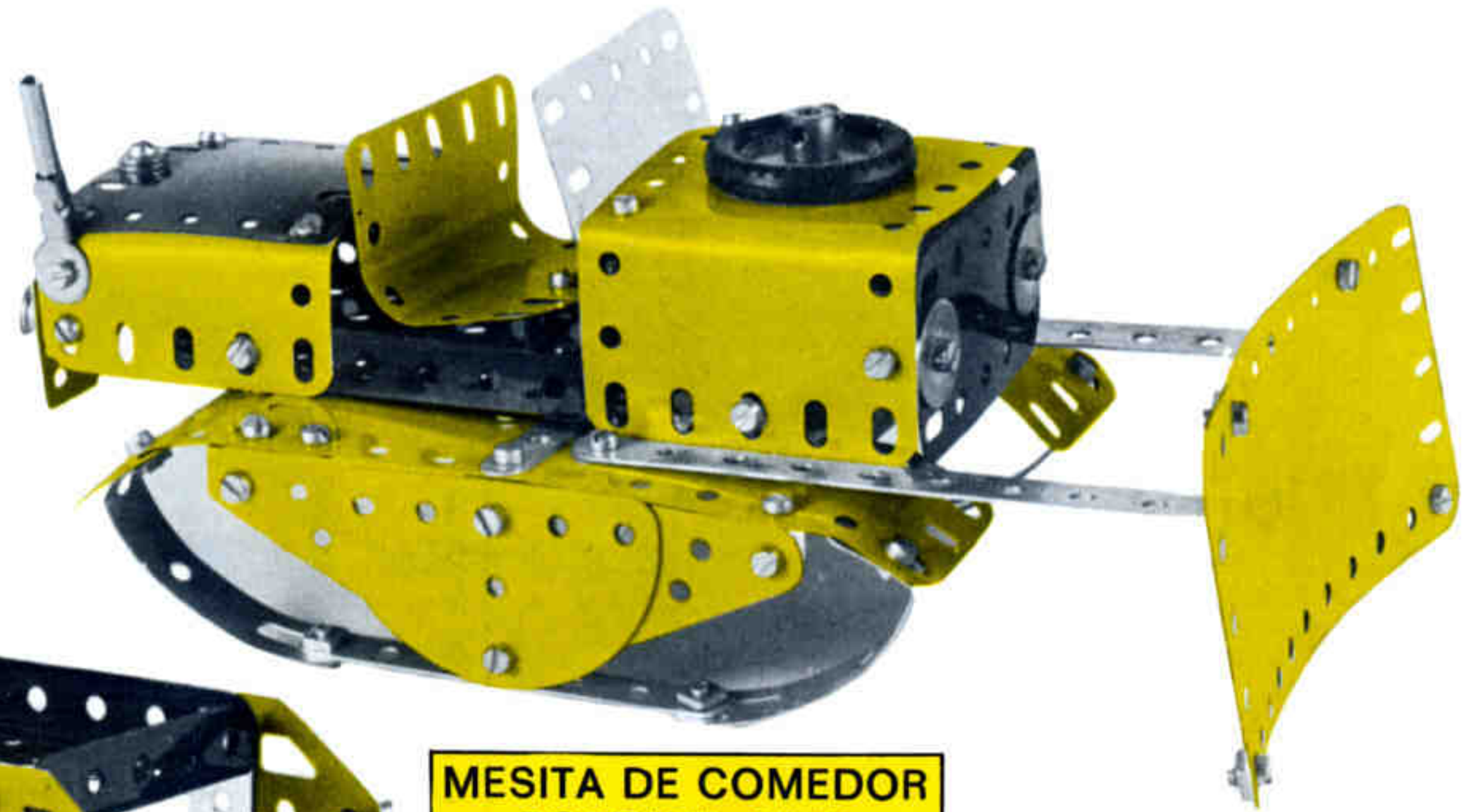

MESITA DE COMEDOR PORTATIL 3/198		
6 - 2	24 - 37a	
4 - 5	24 - 37b	
8 - 12	1 - 52	
3 - 16	2 - 126a	
4 - 22	1 - 190	
2 - 35	1 - 192	

GRUA 3/199		
2 - 1	45 - 37b	
4 - 2	2 - 38	
2 - 5	2 - 48a	
1 - 11	1 - 52	
2 - 12	1 - 57c	
1 - 18b	1 - 111c	
1 - 16	2 - 126	
1 - 20a	2 - 188	
2 - 22	2 - 191	
2 - 22a	1 - 192	
1 - 23	2 - 214	
1 - 24	2 - 235a	
3 - 35	2 - 235b	
46 - 37a		

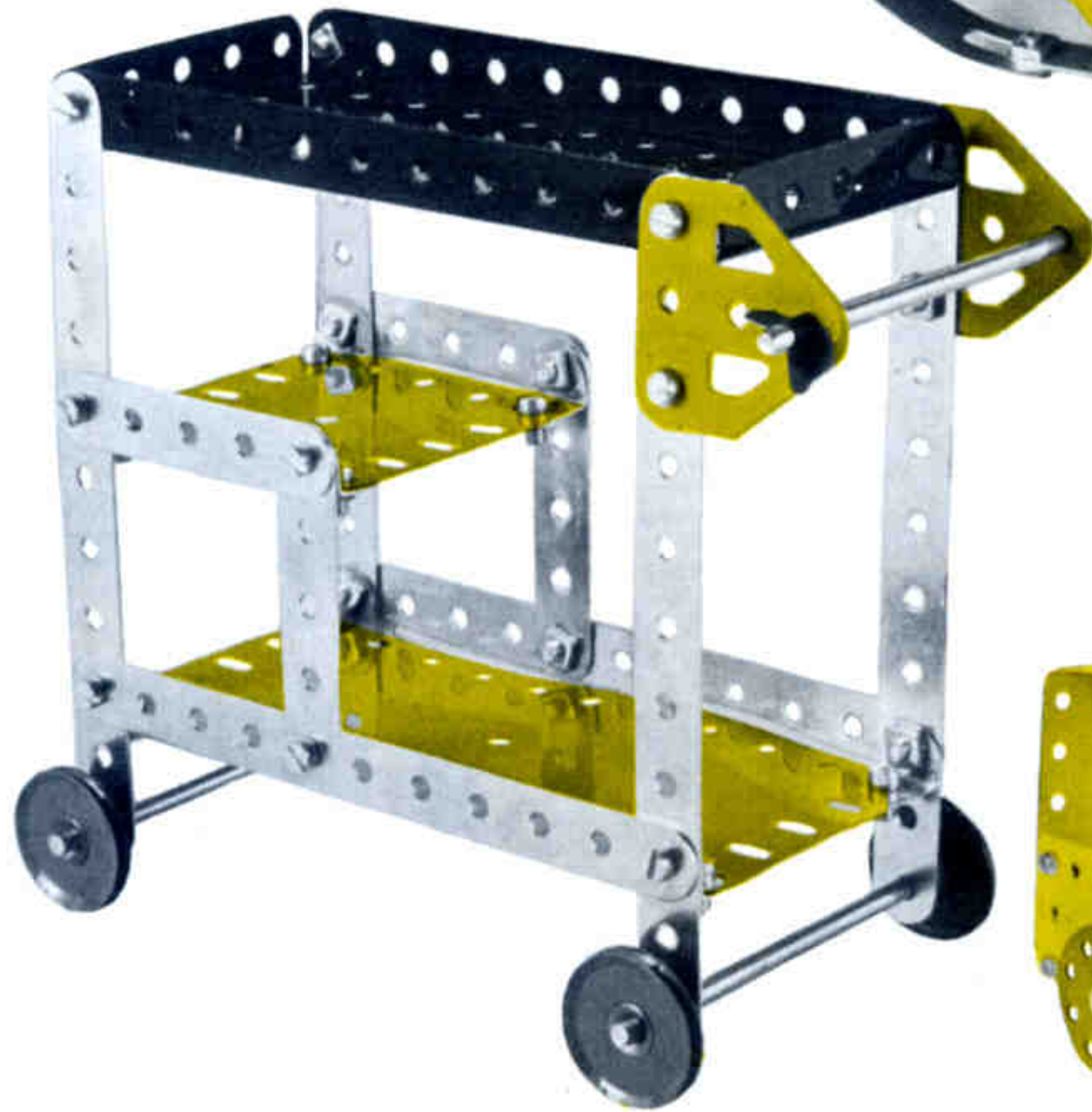

DEPOSITO COMBUSTIBLE 3/196			
2 - 1	5 - 35	1 - 200	
4 - 2	39 - 37a	1 - 212	
5 - 5	39 - 37b	1 - 213	
4 - 12	2 - 48a	2 - 214	
2 - 15b	4 - 90a	3 - 235a	
2 - 16b	2 - 126	1 - 52	
1 - 23	1 - 176		
2 - 24	2 - 192		



LAMPARA DE PIE 3/200

2 - 1	27 - 37a	1 - 190
6 - 2	27 - 37b	4 - 215
4 - 12	1 - 38a	4 - 235a
1 - 16	1 - 52	4 - 235b
1 - 17	1 - 90a	
1 - 24	1 - 126	

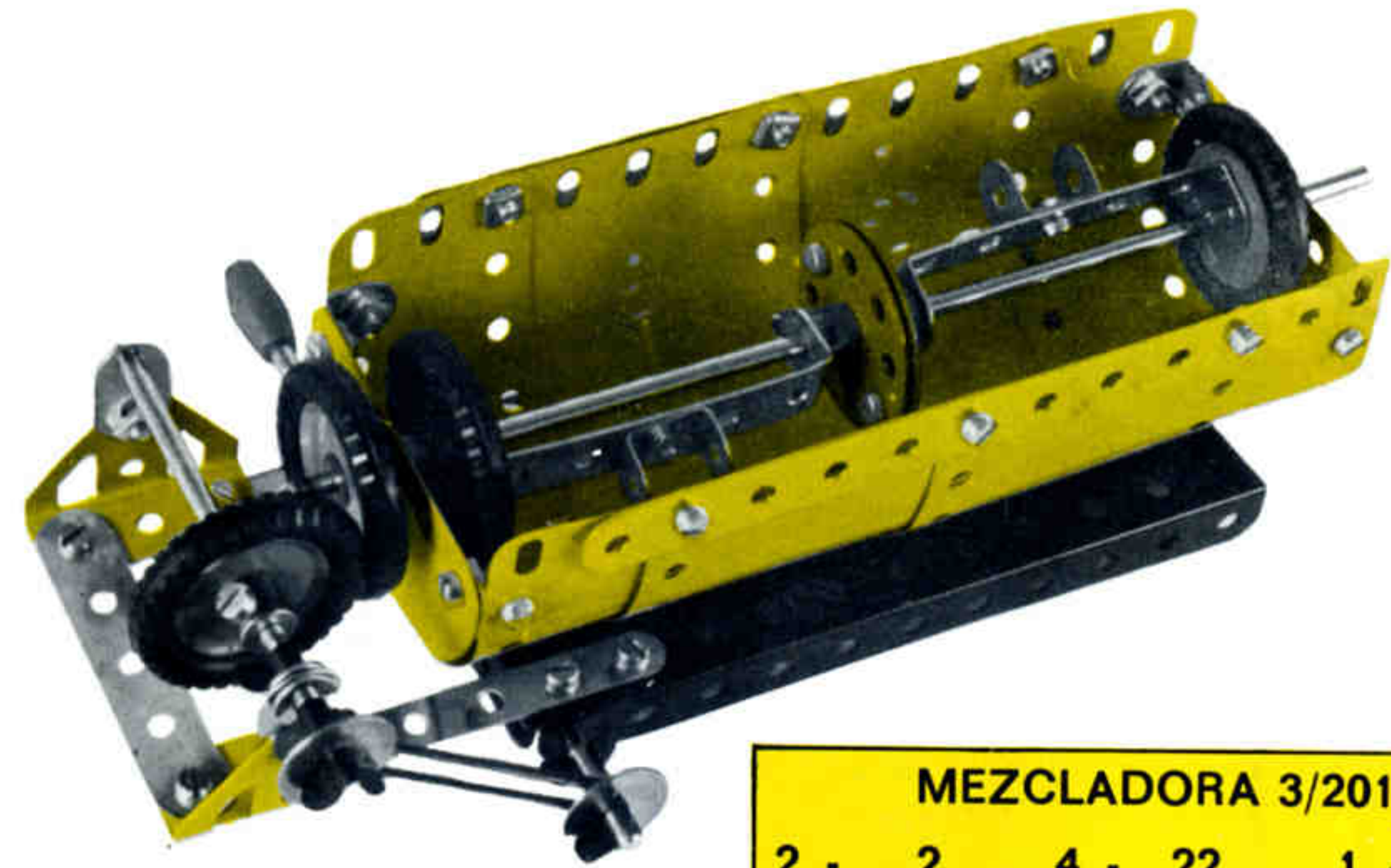

MEZCLADORA 3/201

2 - 2	4 - 22	1 - 52
1 - 5	2 - 24	2 - 126
2 - 10	6 - 35	4 - 142c
2 - 11	35 - 37a	2 - 192
6 - 12	35 - 37b	2 - 214
2 - 15b	3 - 38	2 - 235a
1 - 16	2 - 38d	
1 - 19i	2 - 48a	

LANZACOMETAS 3/202

2 - 1	2 - 24	3 - 111c	1 - 193
3 - 2	6 - 35	2 - 126	1 - 194a
6 - 5	48 - 37a	2 - 126a	1 - 199
5 - 12	45 - 37b	4 - 142c	2 - 221
2 - 15b	2 - 38d	2 - 188	4 - 235a
4 - 22	2 - 11	2 - 189	
2 - 22a	2 - 48a	1 - 190	
1 - 19g	1 - 52	2 - 192	



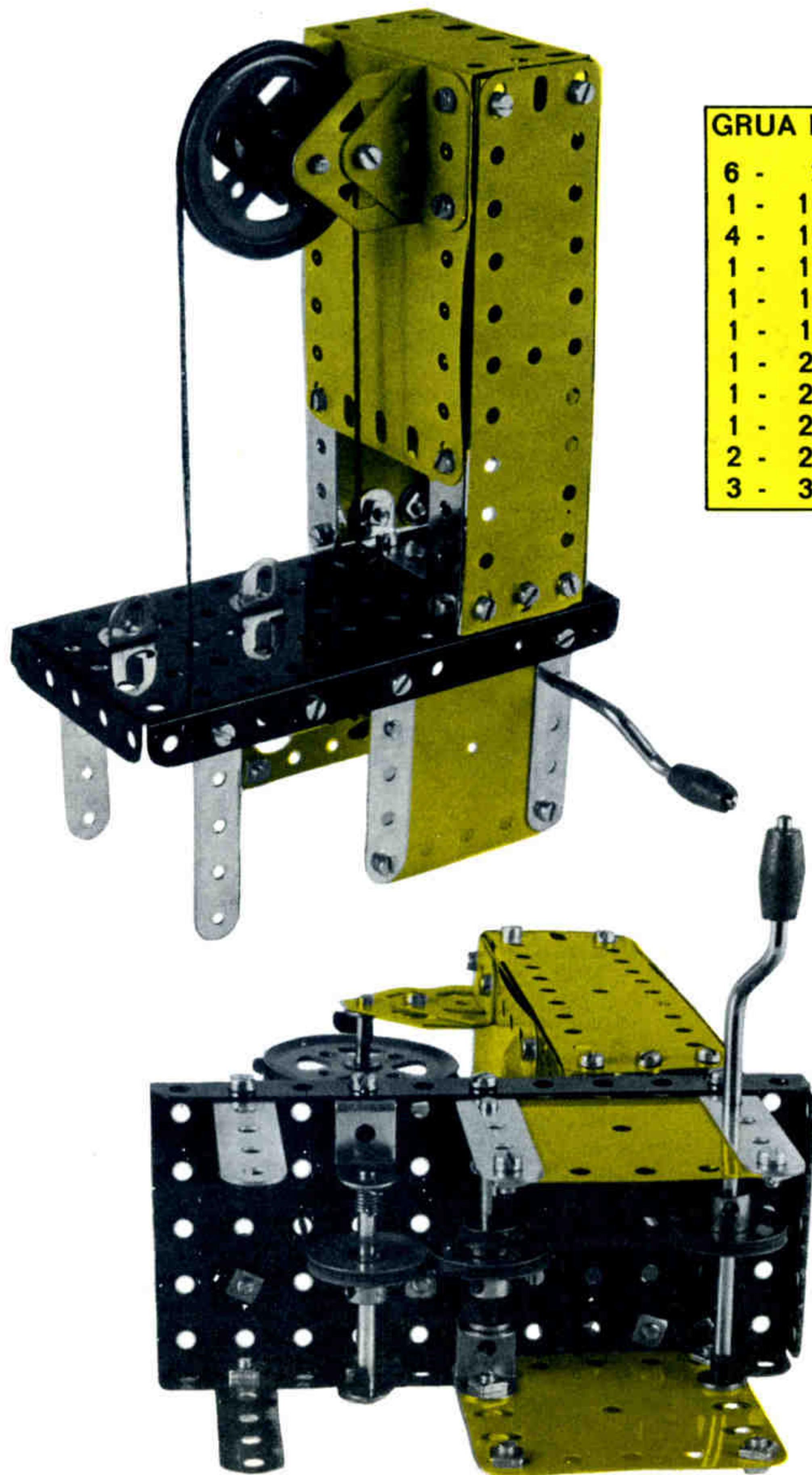

**GRUA DE OBRA 3/204**

6 - 2	24 - 37a
1 - 11	26 - 37b
4 - 12	5 - 38
1 - 17	1 - 40
1 - 18a	2 - 48a
1 - 18b	1 - 52
1 - 22	1 - 57c
1 - 22a	2 - 188
1 - 23	1 - 189
2 - 24	4 - 235a
3 - 35	2 - 235b

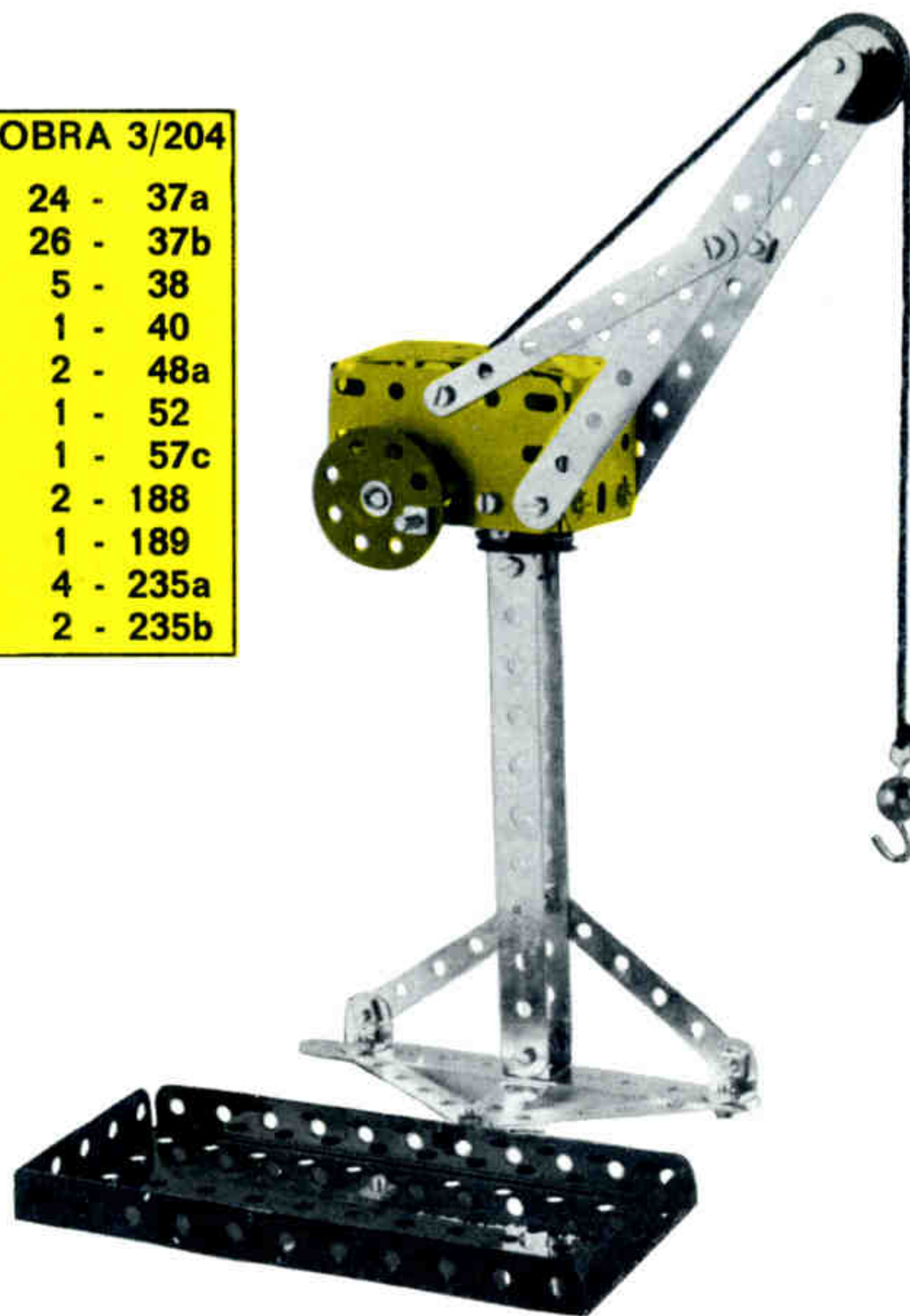

**COHETE 3/205**

1 - 12	15 - 37a
2 - 17	15 - 37b
1 - 20a	2 - 125
1 - 22	2 - 126
2 - 22a	2 - 191
1 - 23	2 - 192
1 - 24	2 - 194a
3 - 35	

**SIERRA CINTA 3/203**

4 - 2	1 - 19g	10 - 38	2 - 189
6 - 5	1 - 20a	1 - 40	2 - 190
1 - 10	3 - 22	2 - 48a	1 - 191
1 - 11	1 - 23	1 - 52	1 - 192
8 - 12	8 - 35	1 - 125	1 - 176
2 - 17	44 - 37a	2 - 126	
1 - 18a	44 - 37b	2 - 126a	





**CARRETILLA DE OBRAS PUBLICAS 3/207**

2 - 5	4 - 22	1 - 52	2 - 189
4 - 10	2 - 24	3 - 90a	2 - 191
2 - 11	2 - 35	3 - 111c	1 - 192
9 - 12	50 - 37a	1 - 125	2 - 194
2 - 16	44 - 37b	1 - 126	2 - 194a
1 - 17	10 - 38	2 - 126a	1 - 213
1 - 18a	1 - 40	4 - 142c	1 - 215
1 - 18b	2 - 48a	1 - 188	2 - 235b

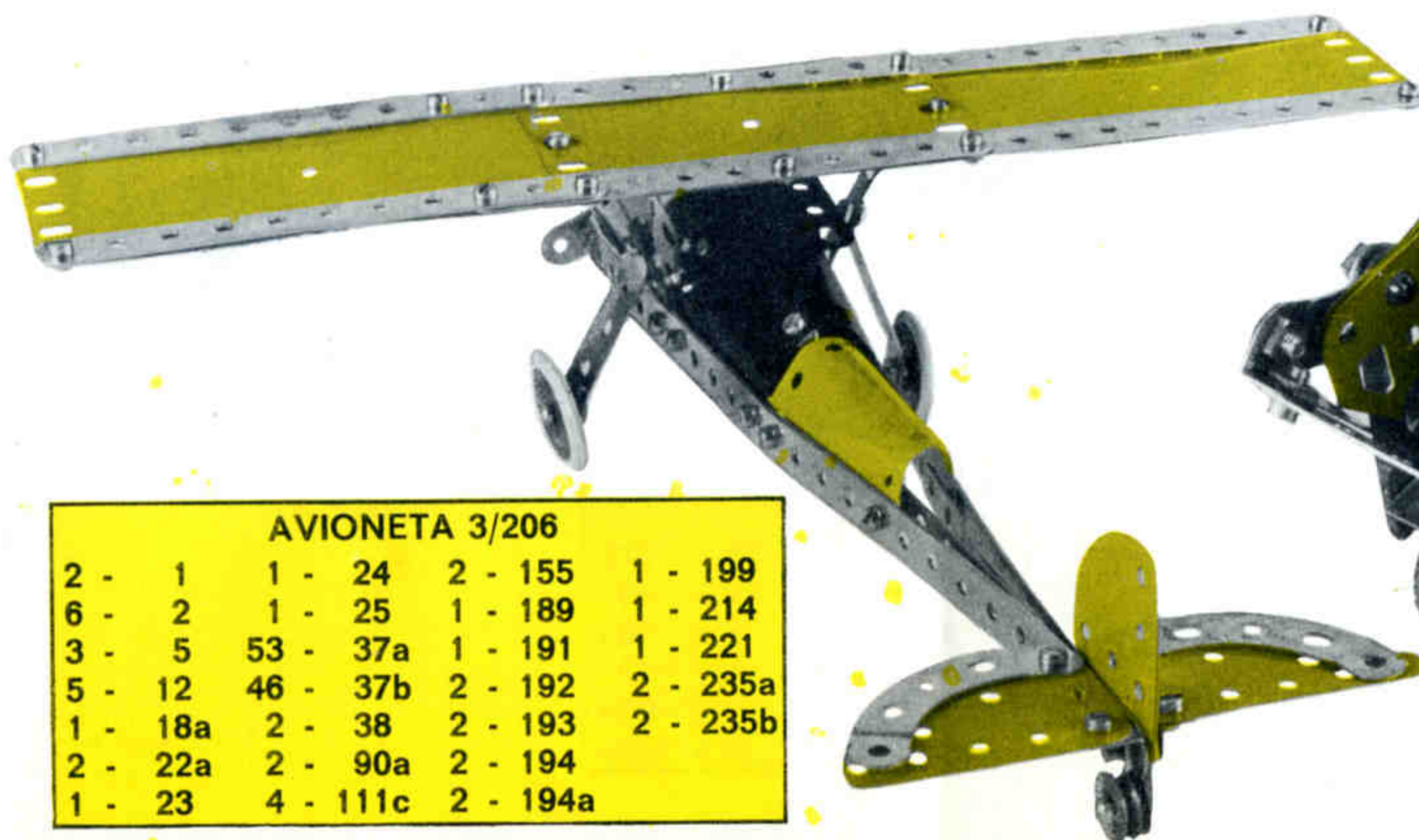
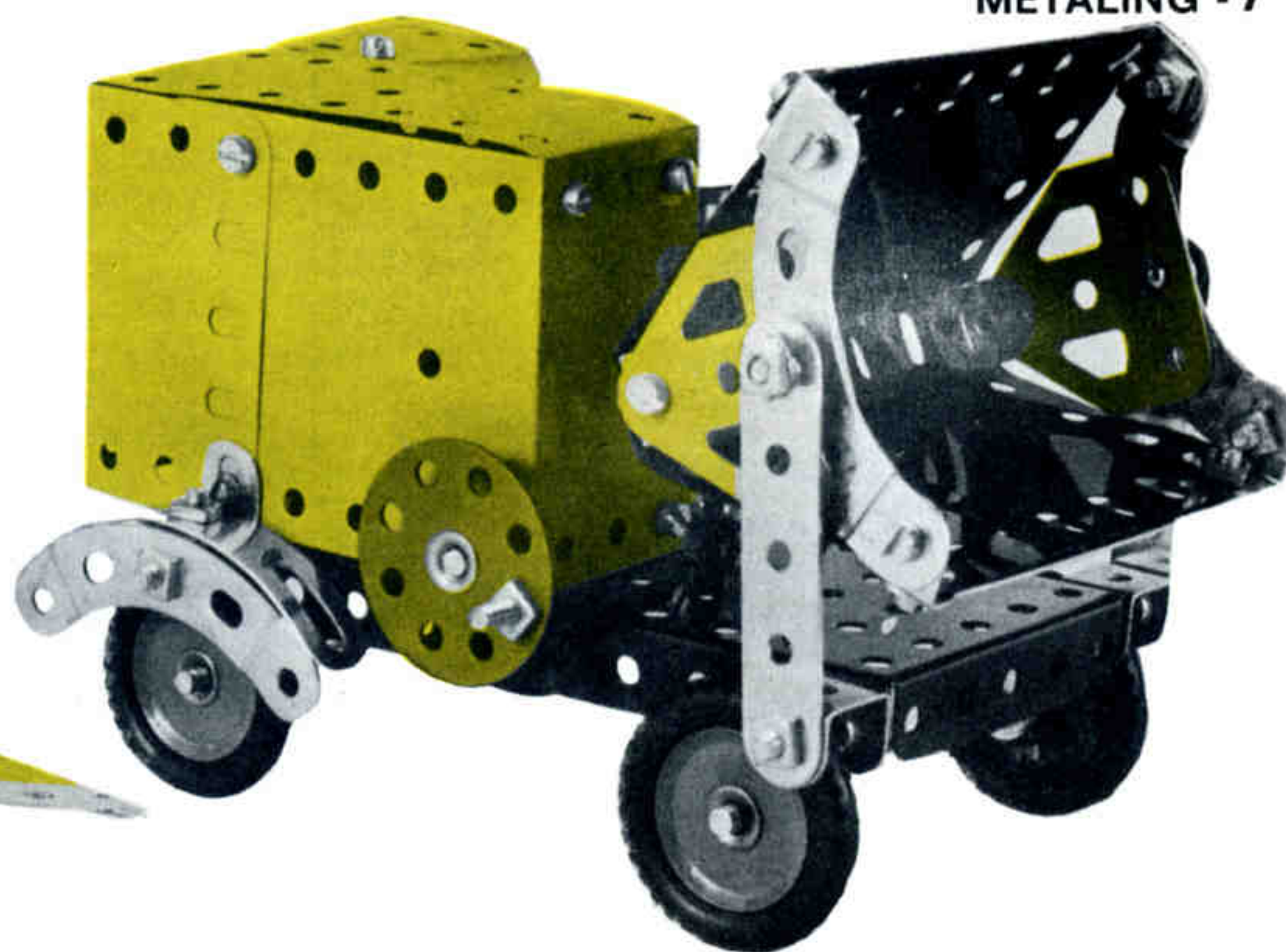
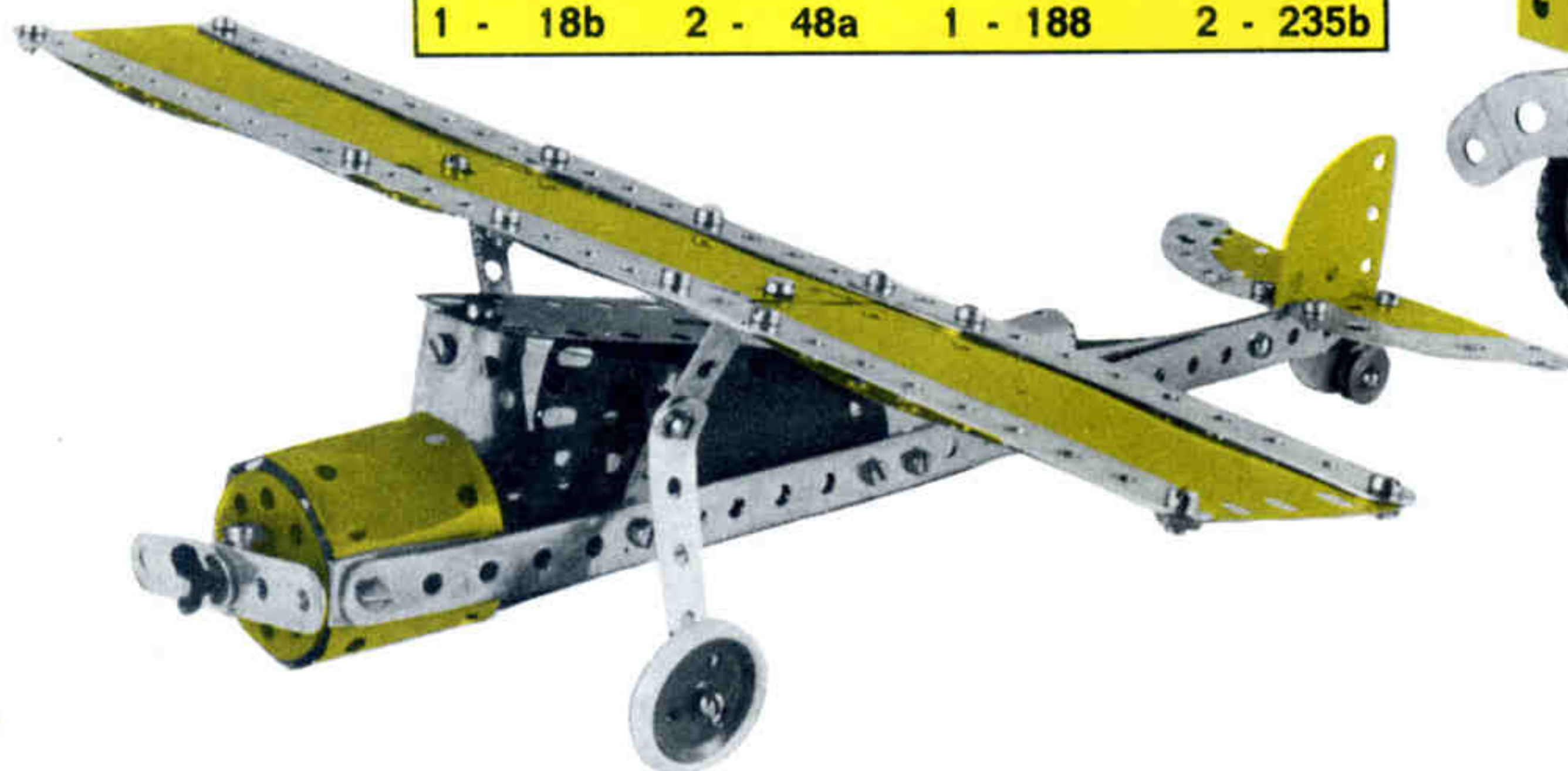

**AVIONETA 3/206**

2 - 1	1 - 24	2 - 155	1 - 199
6 - 2	1 - 25	1 - 189	1 - 214
3 - 5	53 - 37a	1 - 191	1 - 221
5 - 12	46 - 37b	2 - 192	2 - 235a
1 - 18a	2 - 38	2 - 193	2 - 235b
2 - 22a	2 - 90a	2 - 194	
1 - 23	4 - 111c	2 - 194a	

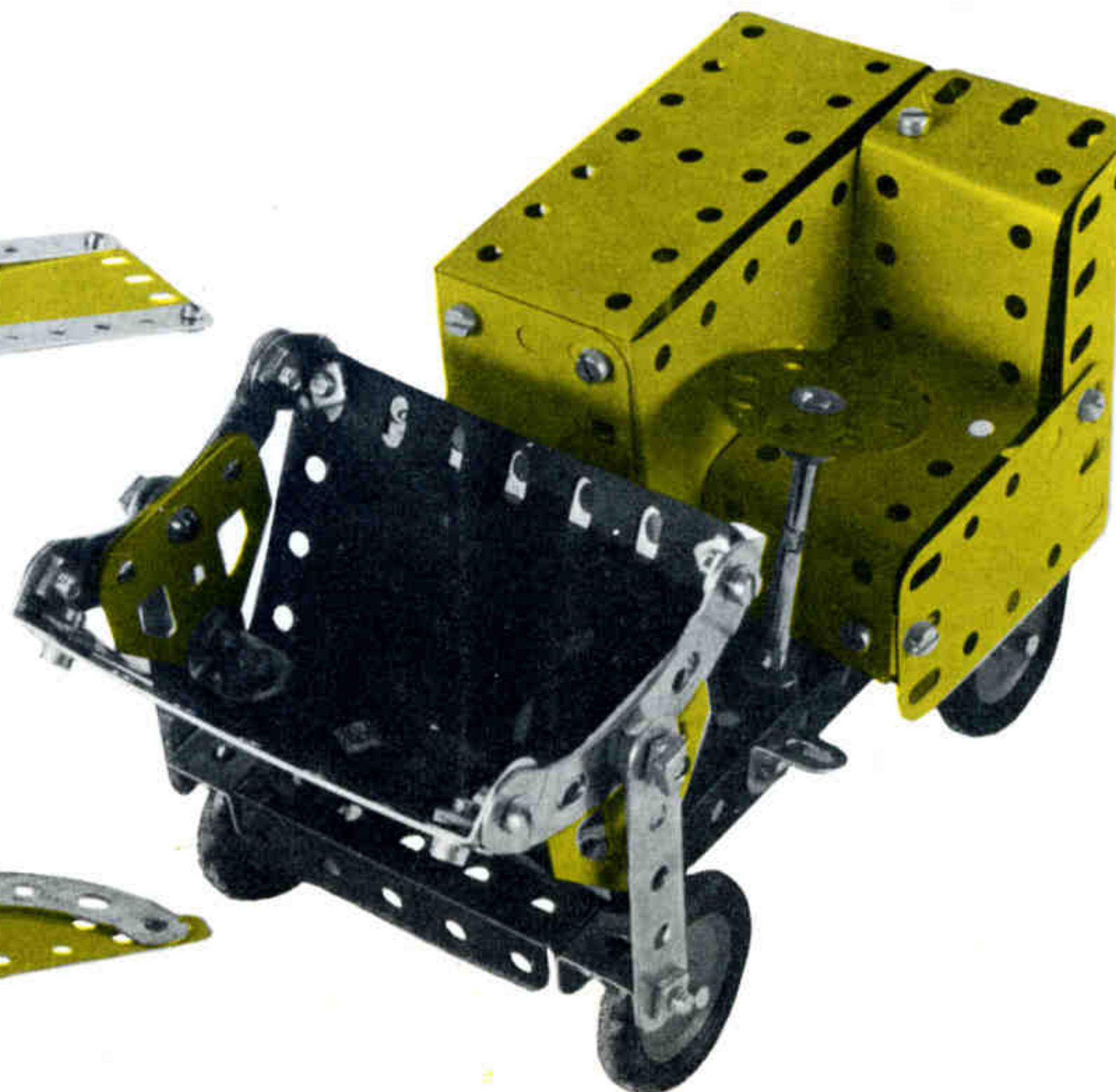

METALING - 8

**CAMION ARTICULADO 3/208**

2 - 1	4 - 22	2 - 38d	2 - 191
1 - 2	2 - 22a	2 - 48a	2 - 192
1 - 5	1 - 23	1 - 52	1 - 193
2 - 11	1 - 24	2 - 111c	1 - 213
5 - 10	2 - 35	2 - 126	1 - 214
10 - 12	53 - 37a	4 - 142c	2 - 215
2 - 16	51 - 37b	2 - 155	
2 - 17	10 - 38	2 - 188	

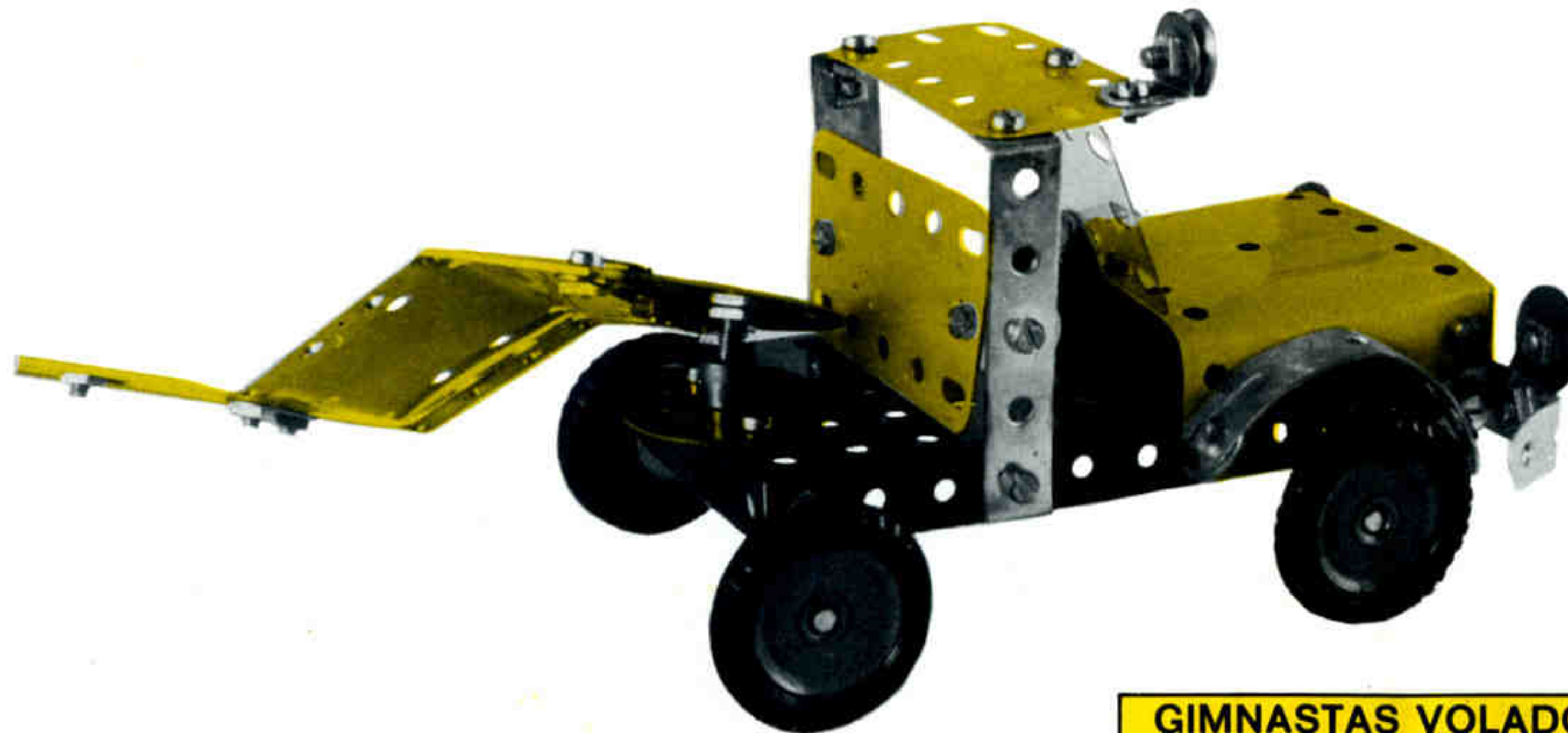
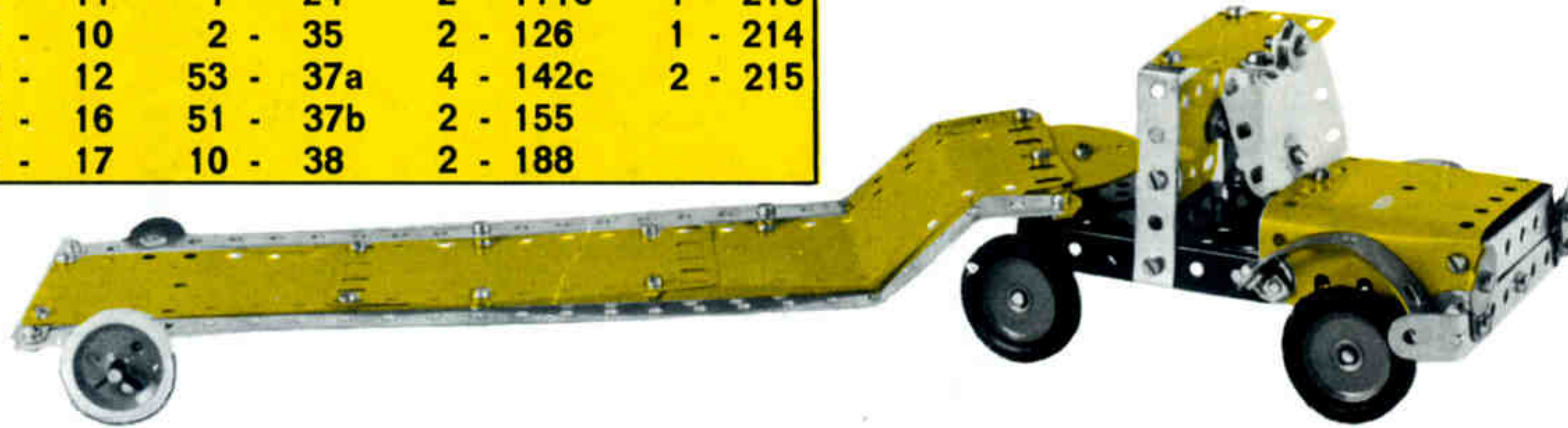

**GIMNASTAS VOLADORES 3/209**

2 - 1	1 - 16	38 - 37b
3 - 2	2 - 17	1 - 40
8 - 5	4 - 22	2 - 48a
2 - 10	1 - 24	1 - 52
2 - 11	4 - 35	1 - 90a
10 - 12	36 - 37a	2 - 126a

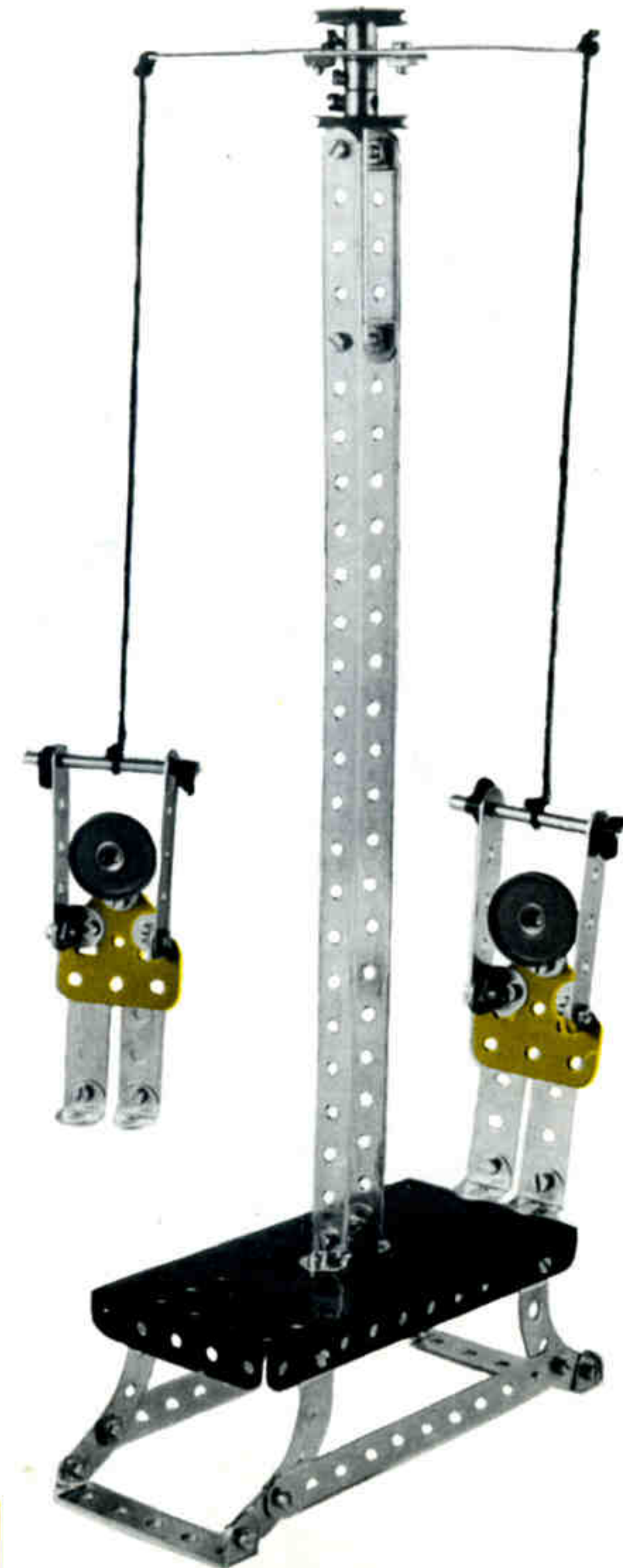

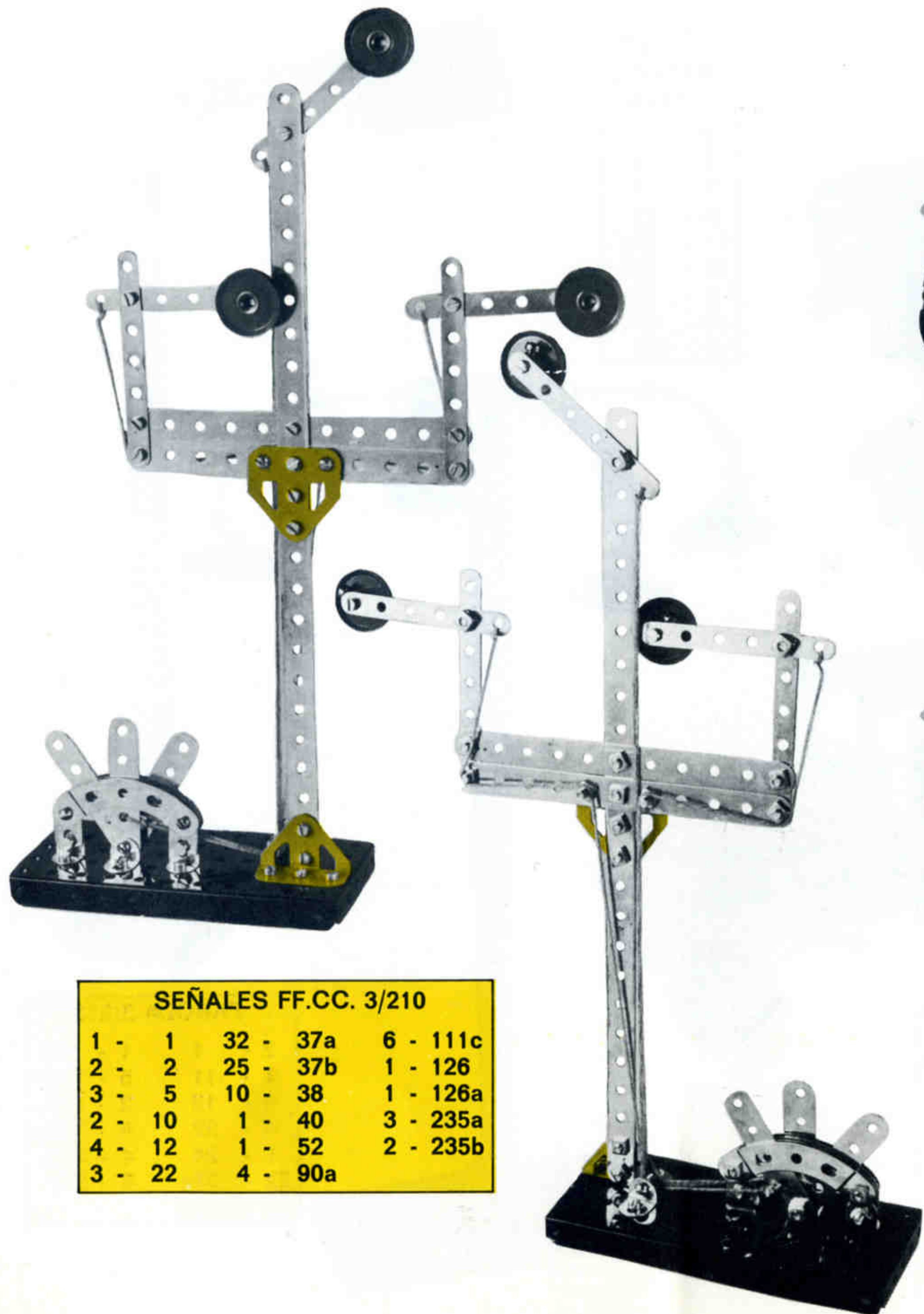

SEÑALES FF.CC. 3/210					
1 -	1	32 -	37a	6 -	111c
2 -	2	25 -	37b	1 -	126
3 -	5	10 -	38	1 -	126a
2 -	10	1 -	40	3 -	235a
4 -	12	1 -	52	2 -	235b
3 -	22	4 -	90a		

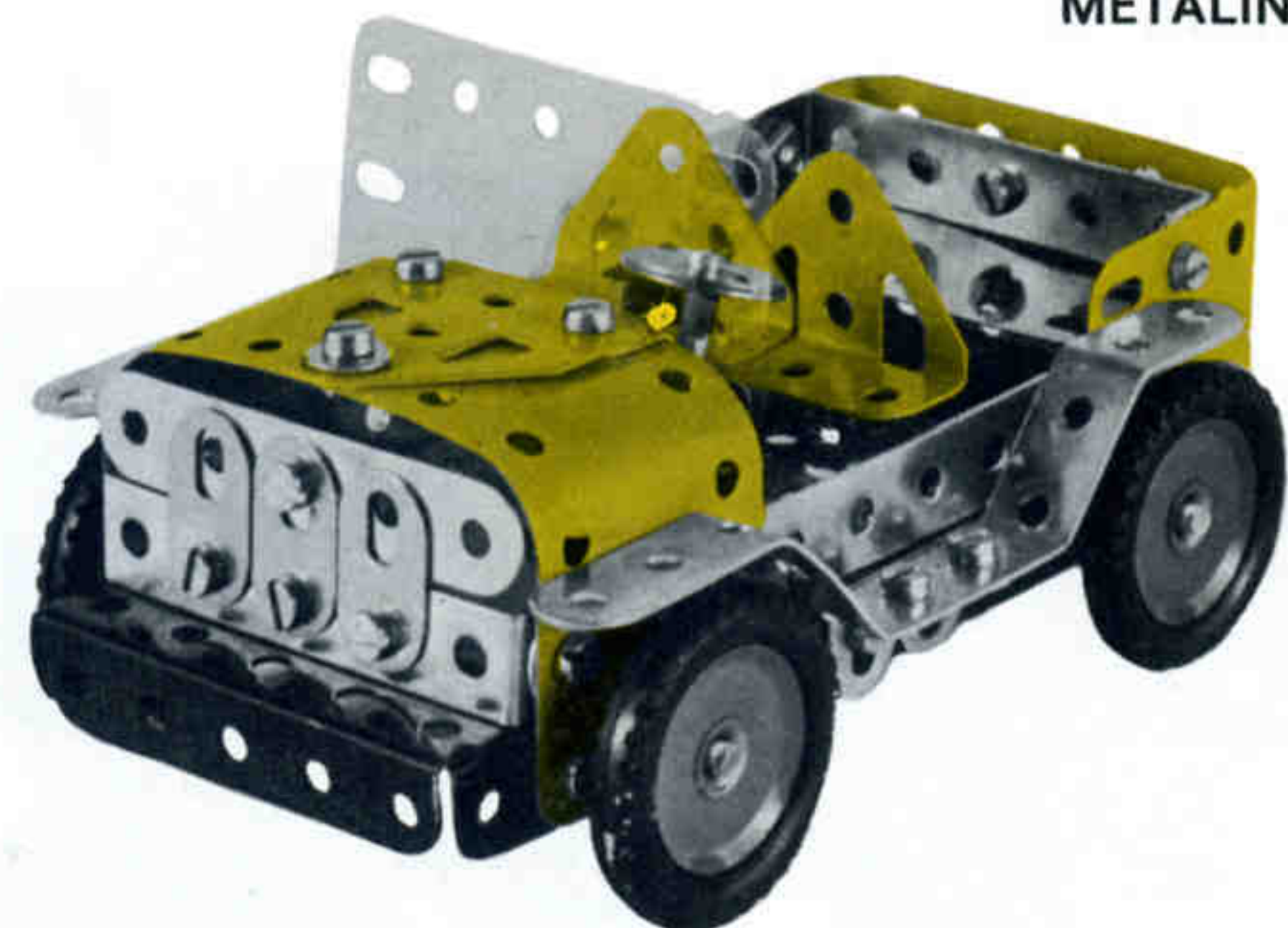

JEEP 3/211					
4 -	2	33 -	37a	2 -	126
1 -	5	32 -	37b	1 -	126a
3 -	10	8 -	38	4 -	142a
7 -	12	2 -	38d	2 -	155
2 -	16	2 -	48a	2 -	189
1 -	17	1 -	52	1 -	193
4 -	22	1 -	111c	1 -	194
2 -	22a	2 -	125	3 -	35

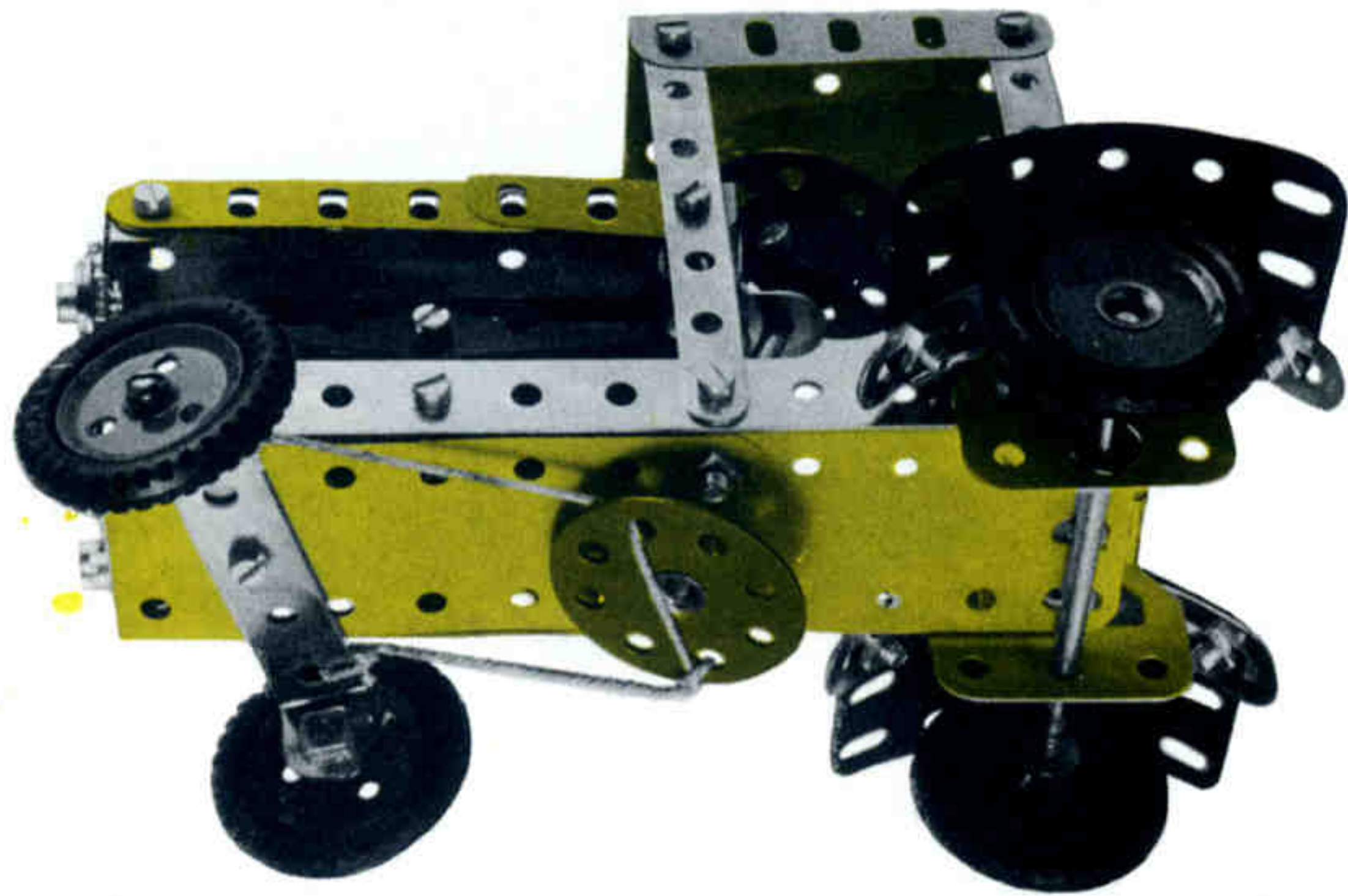

**LUZ DE BACULO 3/214**

2 -	1
2 -	2
2 -	11
2 -	12
11 -	37a
11 -	37b
1 -	52
2 -	90a
1 -	199

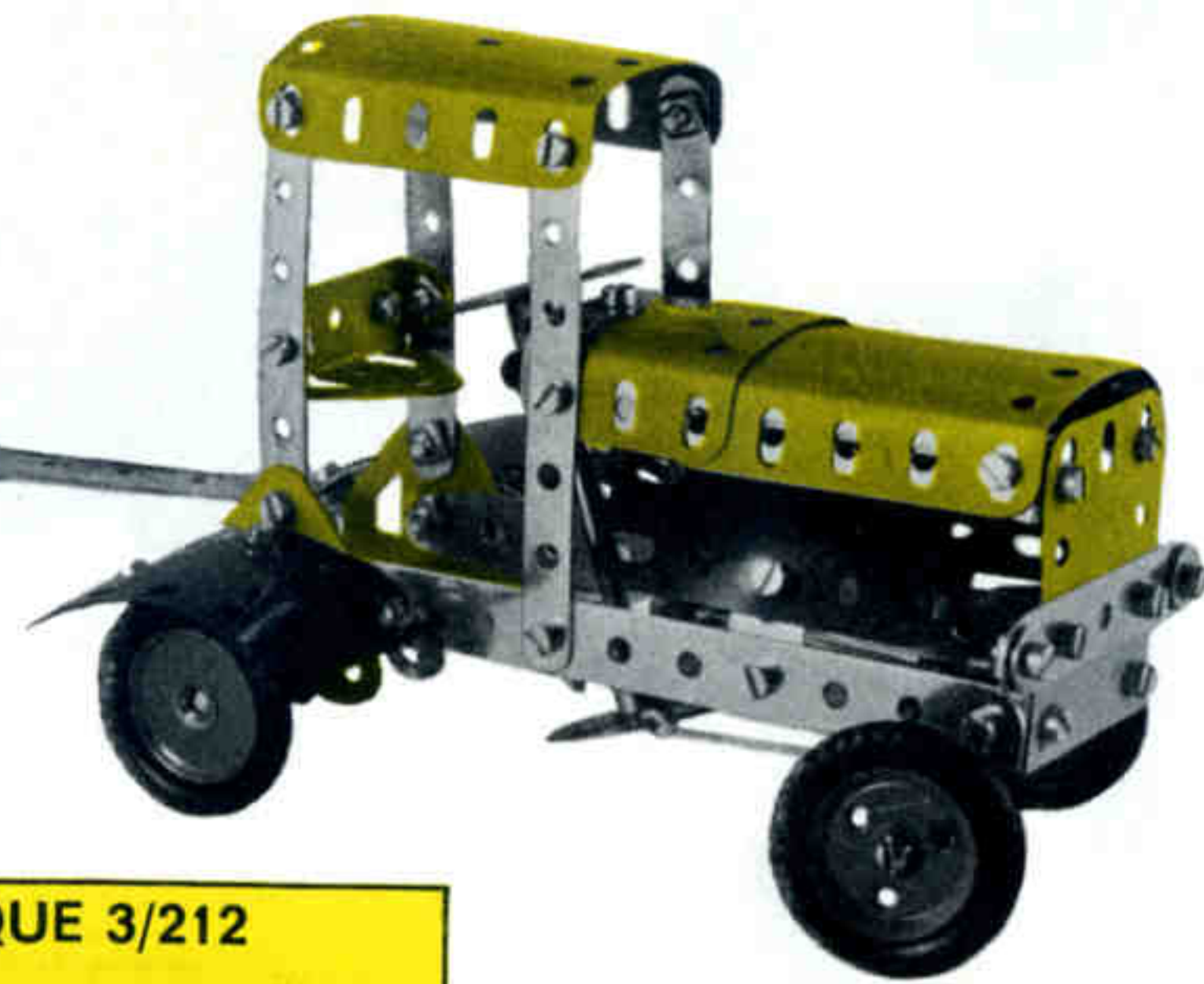
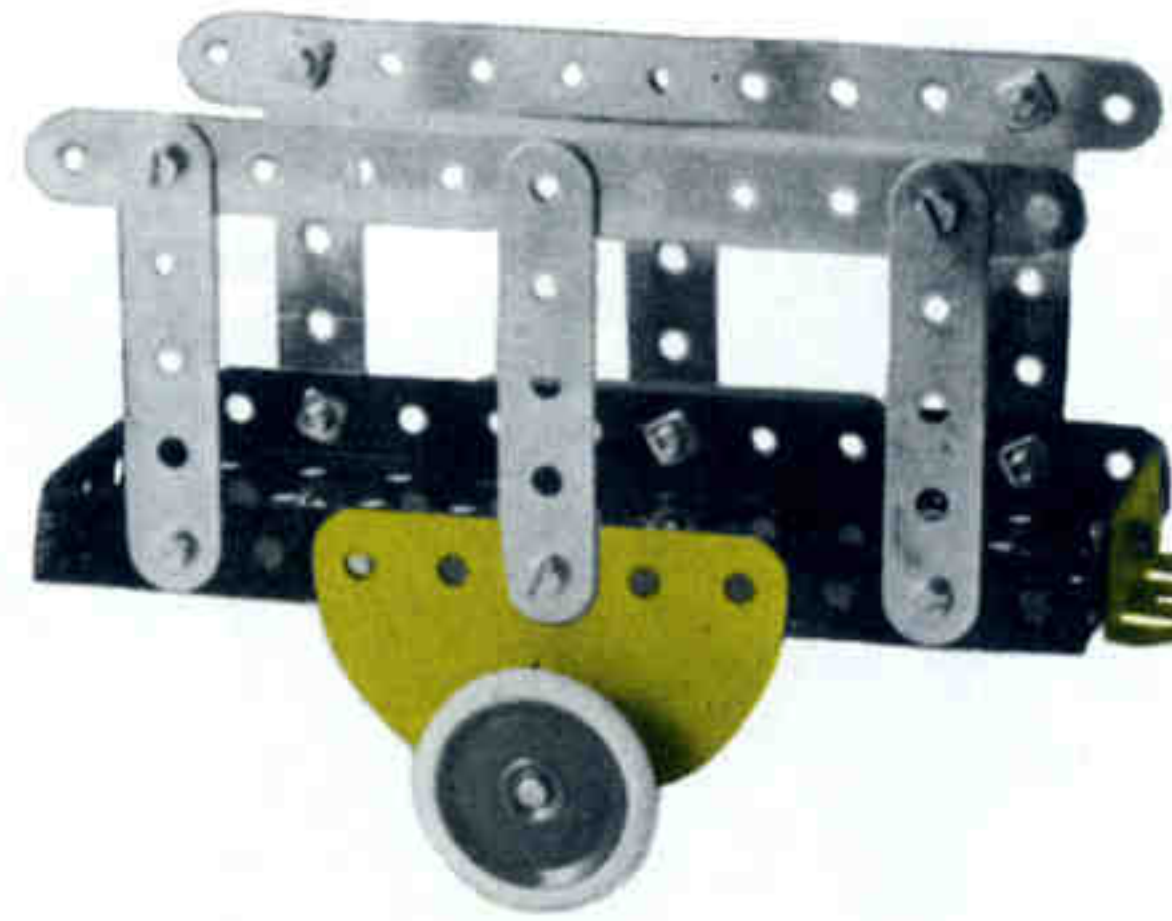

**TRACTOR CON REMOLQUE 3/212**

4 -	2	2 -	24	2 -	125	1 -	194a
8 -	5	3 -	35	2 -	126	1 -	199
2 -	10	58 -	37a	2 -	126a	1 -	213
10 -	12	56 -	37b	4 -	142c	2 -	214
2 -	16	5 -	38	2 -	155	2 -	215
1 -	18a	1 -	40	2 -	188	2 -	235a
1 -	18b	1 -	48a	1 -	189	4 -	235b
4 -	22	1 -	52	1 -	190		
2 -	22a	1 -	111c	2 -	194		



**FAROLA 3/213**

2 -	1	1 -	52
1 -	11	5 -	111c
4 -	12	2 -	126
4 -	22	4 -	142c
1 -	24	4 -	215
22 -	37a	4 -	221
22 -	37b		



**NORIA 3/215**

6 - 2	4 - 35
2 - 11	14 - 37a
1 - 16	18 - 37b
1 - 19i	6 - 38
1 - 20a	1 - 52
4 - 22	4 - 111c
1 - 23	4 - 142c
1 - 24	2 - 214

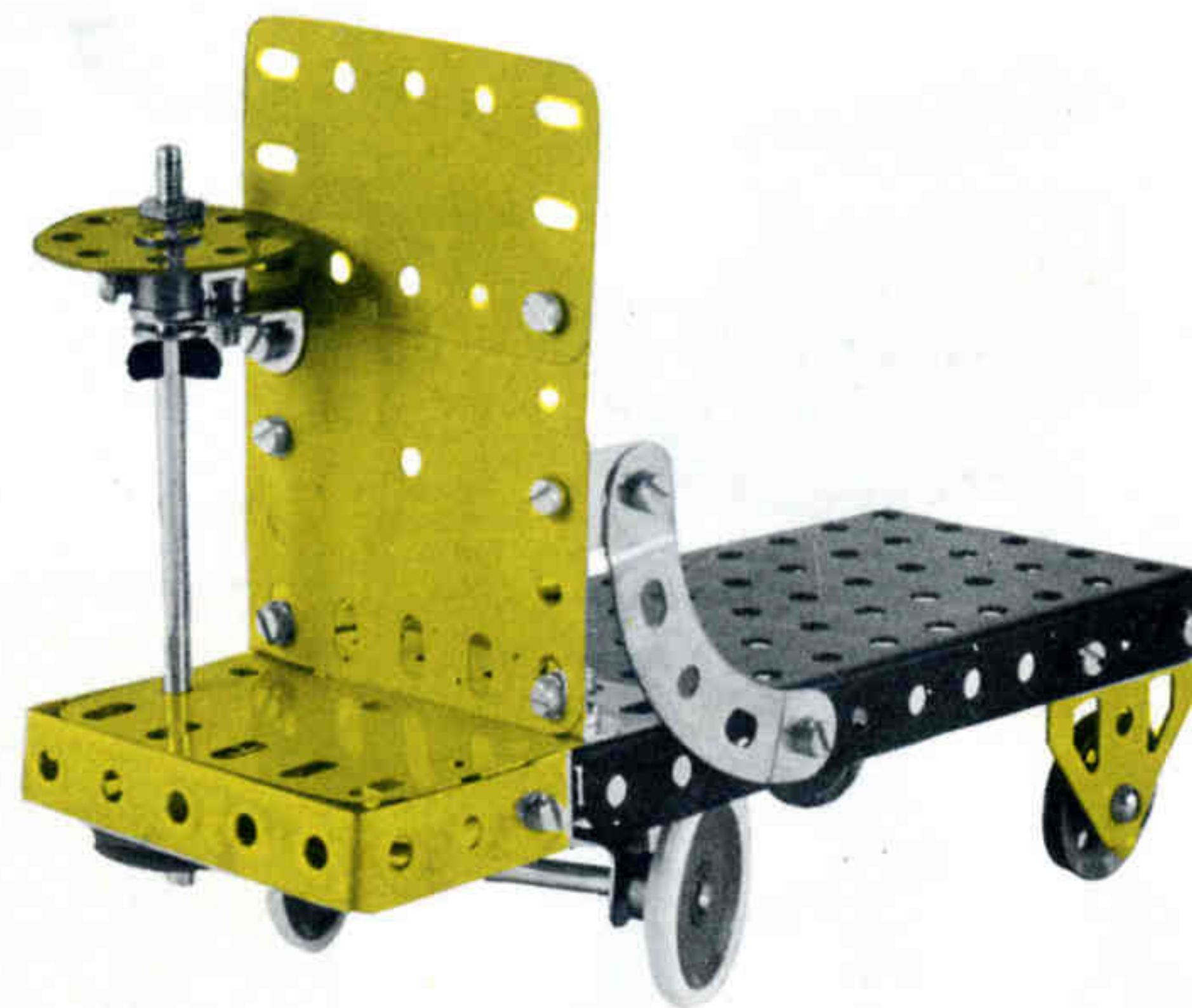

**CARRETILLA ELECTRICA 3/216**

1 - 2	1 - 23	2 - 90a
1 - 5	1 - 24	5 - 111c
1 - 10	1 - 35	2 - 125
6 - 12	32 - 37a	2 - 126a
1 - 16	4 - 38	2 - 155
1 - 17	1 - 40	1 - 188
4 - 22	1 - 48a	2 - 190
2 - 22a	1 - 52	25 - 37b

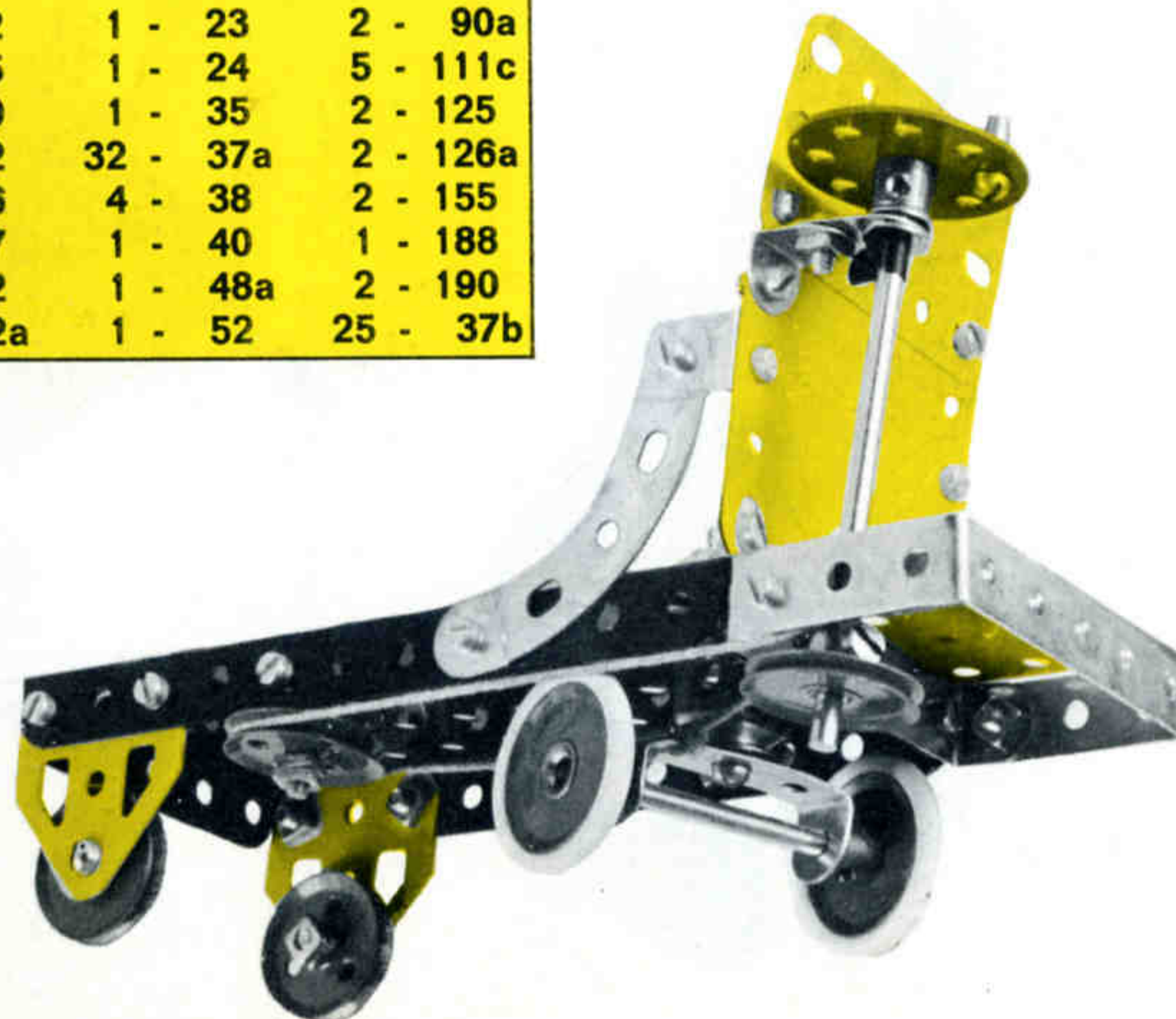

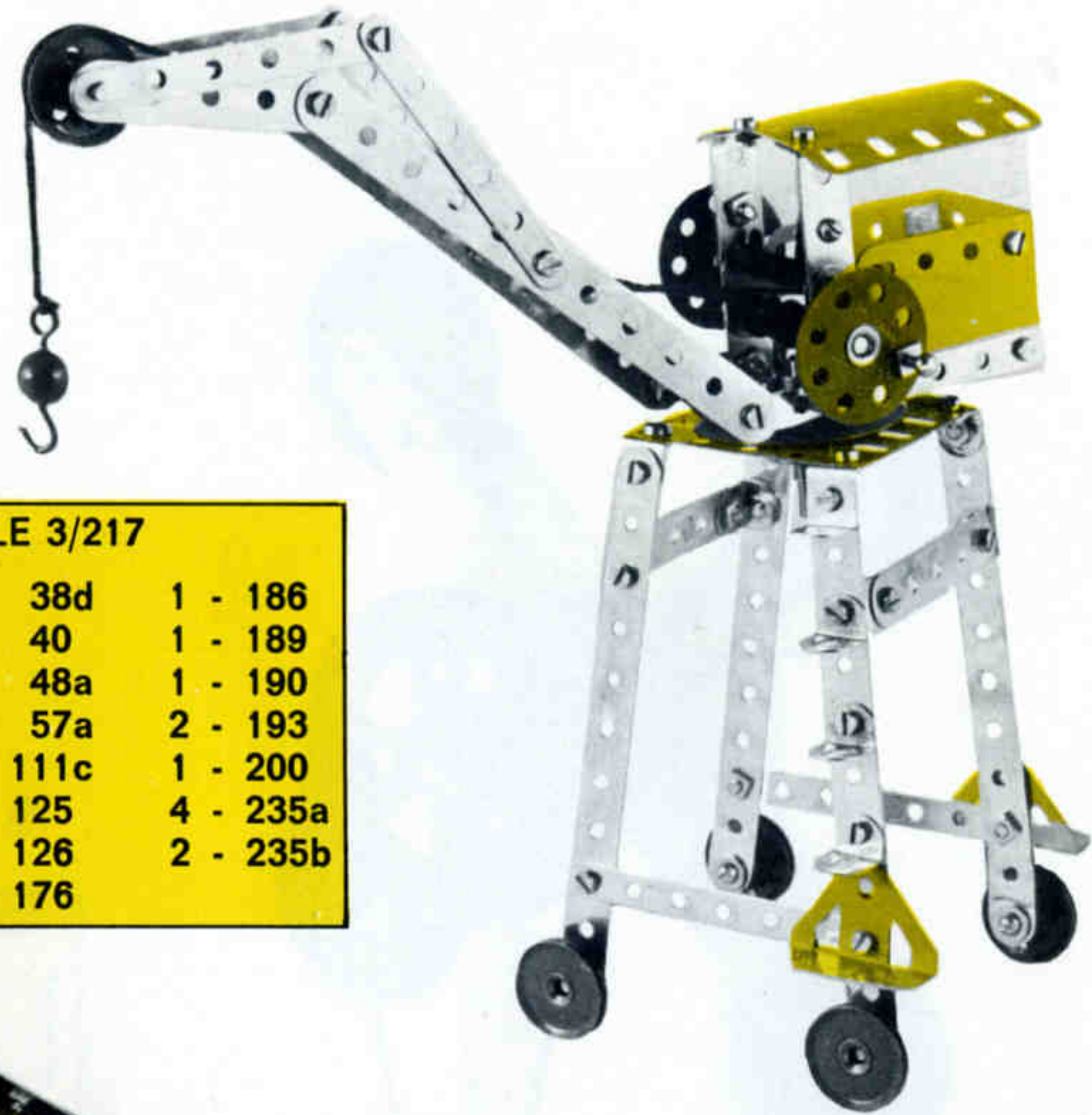
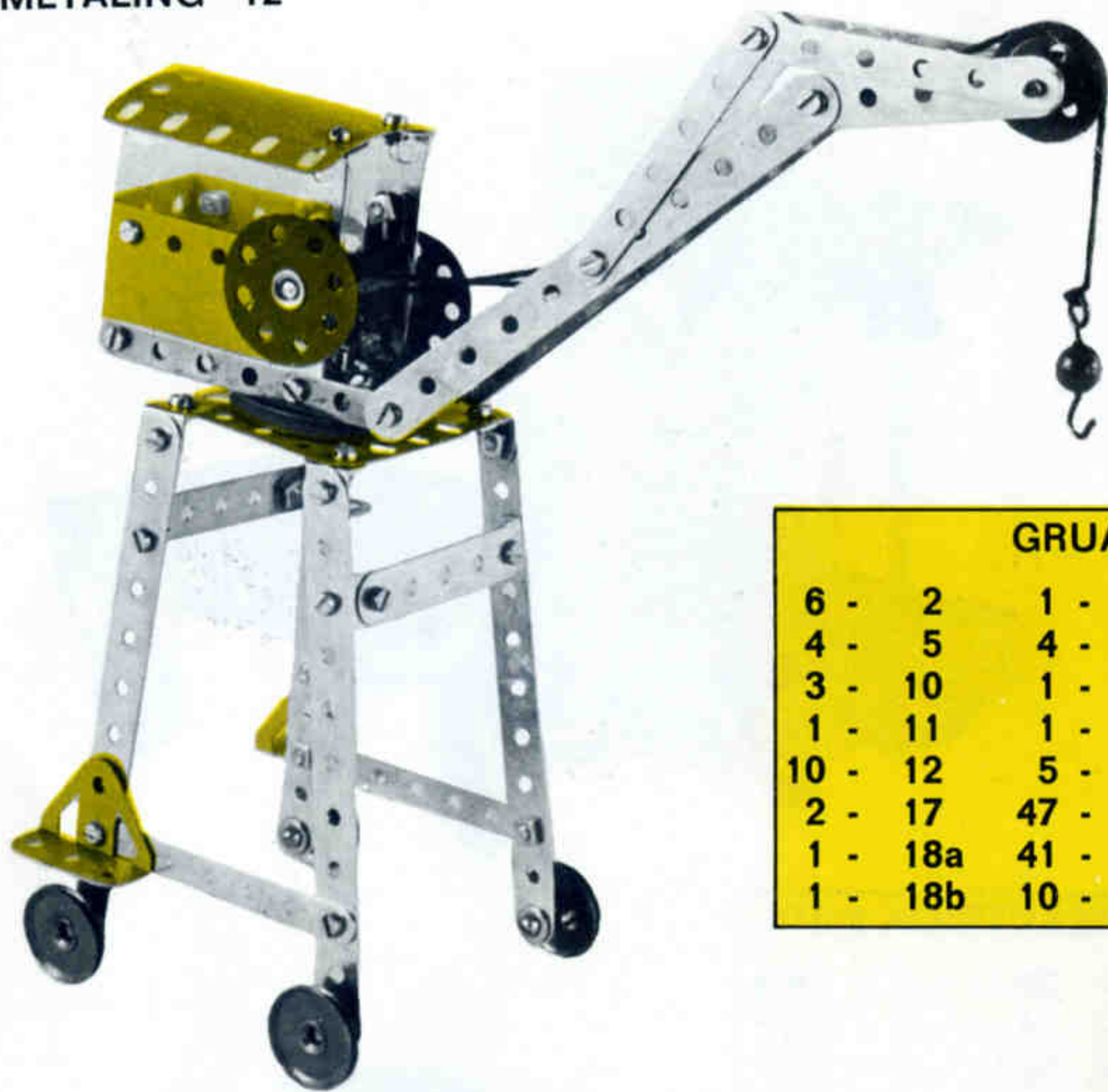

**GRUA DE MUELLE 3/217**

6 - 2	1 - 20a	2 - 38d	1 - 186
4 - 5	4 - 22	1 - 40	1 - 189
3 - 10	1 - 22a	2 - 48a	1 - 190
1 - 11	1 - 24	1 - 57a	2 - 193
10 - 12	5 - 35	6 - 111c	1 - 200
2 - 17	47 - 37a	2 - 125	4 - 235a
1 - 18a	41 - 37b	2 - 126	2 - 235b
1 - 18b	10 - 38	1 - 176	

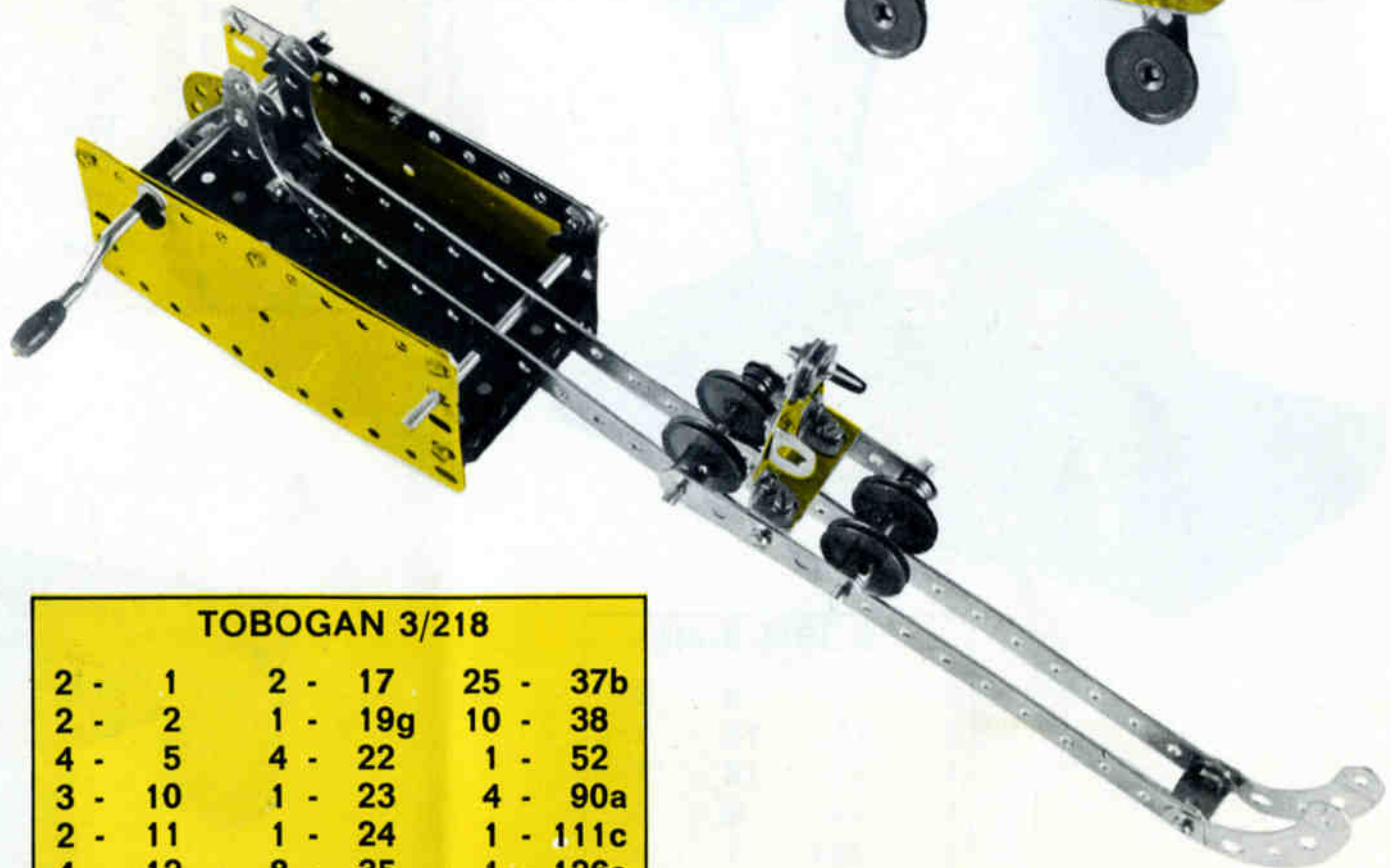

**TOBOGAN 3/218**

2 - 1	2 - 17	25 - 37b
2 - 2	1 - 19g	10 - 38
4 - 5	4 - 22	1 - 52
3 - 10	1 - 23	4 - 90a
2 - 11	1 - 24	1 - 111c
4 - 12	8 - 35	1 - 126a
1 - 16	26 - 37a	2 - 192

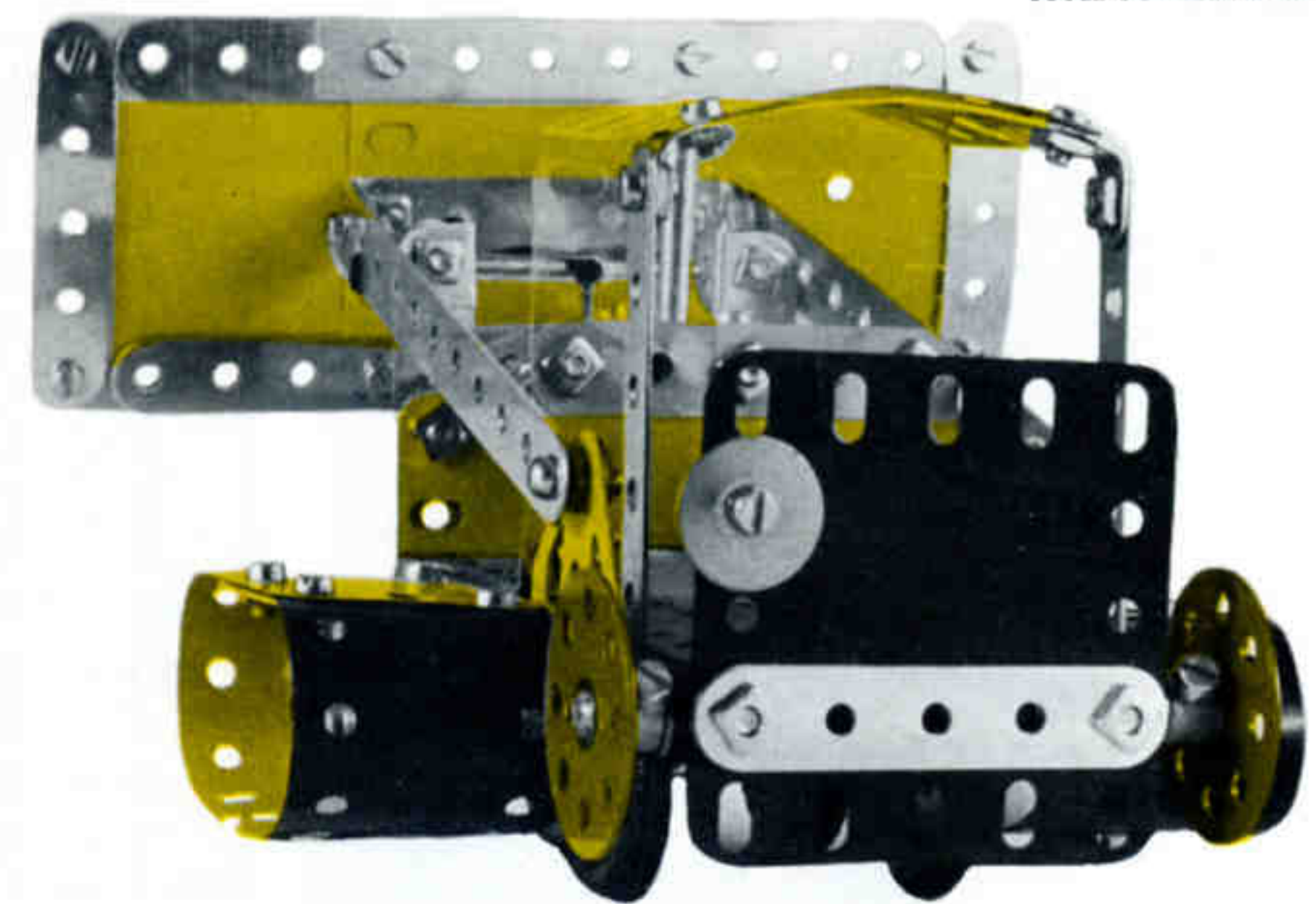
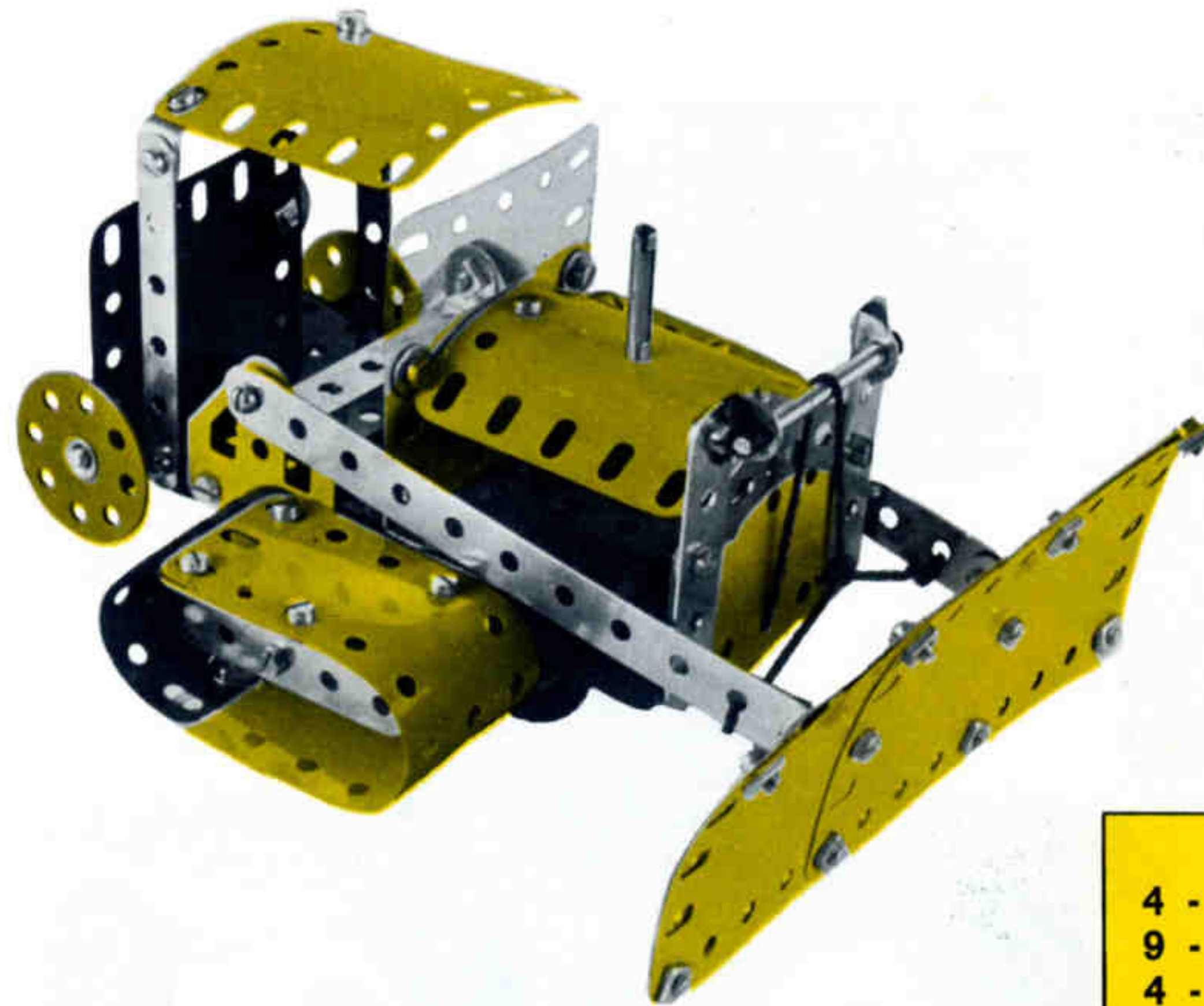

**MAQUINA PLANADORA 3/219**

4 -	2	1 -	18a	55 -	37b	1 -	90a	2 -	188	1 -	194a
9 -	5	1 -	18b	6 -	38	3 -	111c	2 -	189	1 -	200
4 -	10	4 -	22	1 -	38d	2 -	126	1 -	190	1 -	212
10 -	12	2 -	24	1 -	40	2 -	126a	2 -	191	1 -	213
3 -	16	5 -	35	2 -	48a	4 -	142c	1 -	193	3 -	235b
1 -	17	61 -	37a	1 -	52	1 -	186	2 -	194	1 -	176

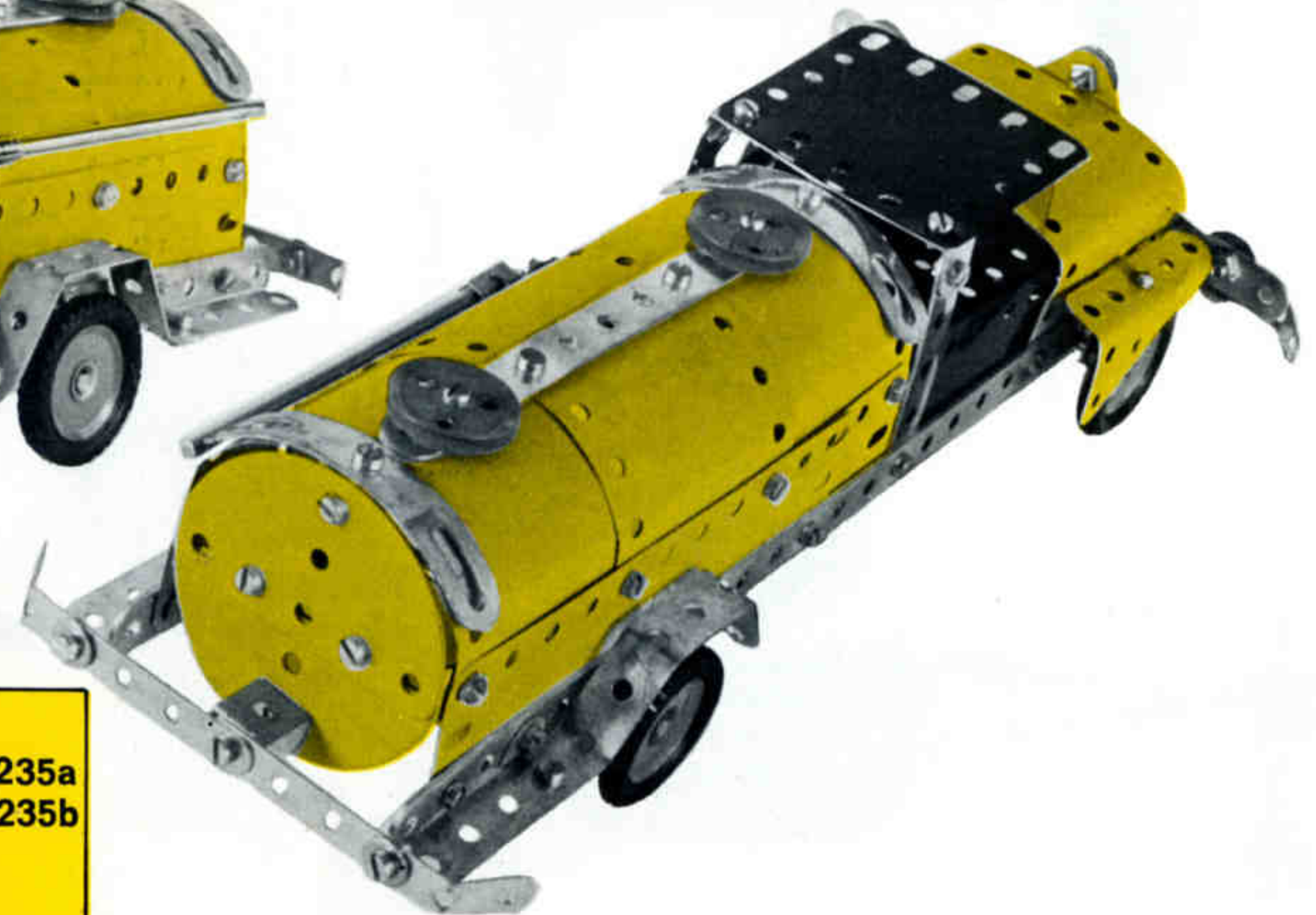
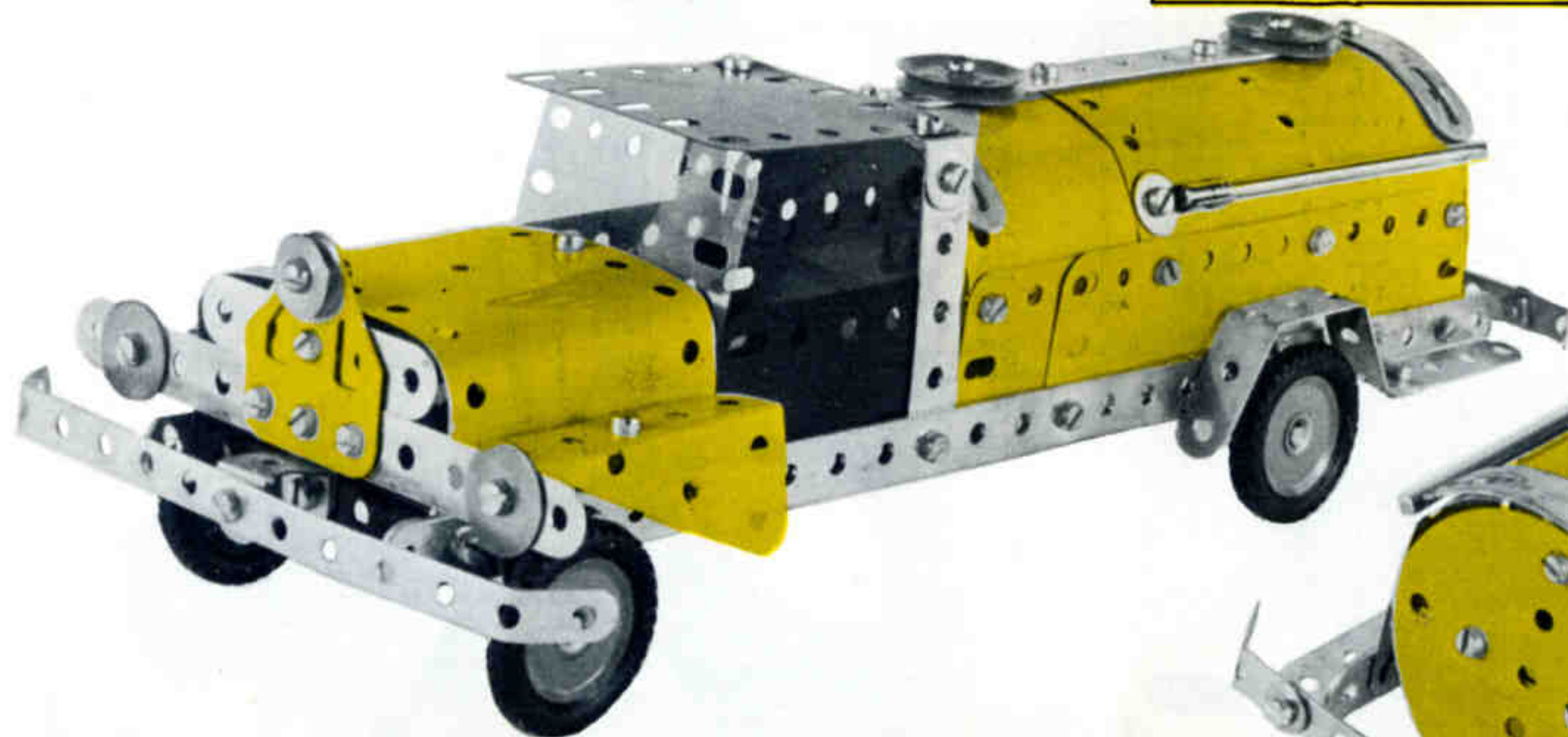

**CAMION CISTERNA 3/220**

2 -	1	4 -	10	1 -	23	2 -	48a	4 -	142c	1 -	193	2 -	235a
4 -	2	1 -	15b	59 -	37a	1 -	52	2 -	188	2 -	194	4 -	235b
3 -	5	2 -	16	55 -	37b	4 -	111c	2 -	189	1 -	194a		
2 -	11	4 -	22	6 -	38	2 -	126	2 -	191	2 -	215		
4 -	12	2 -	22a	2 -	38d	1 -	126a	2 -	192	2 -	221		

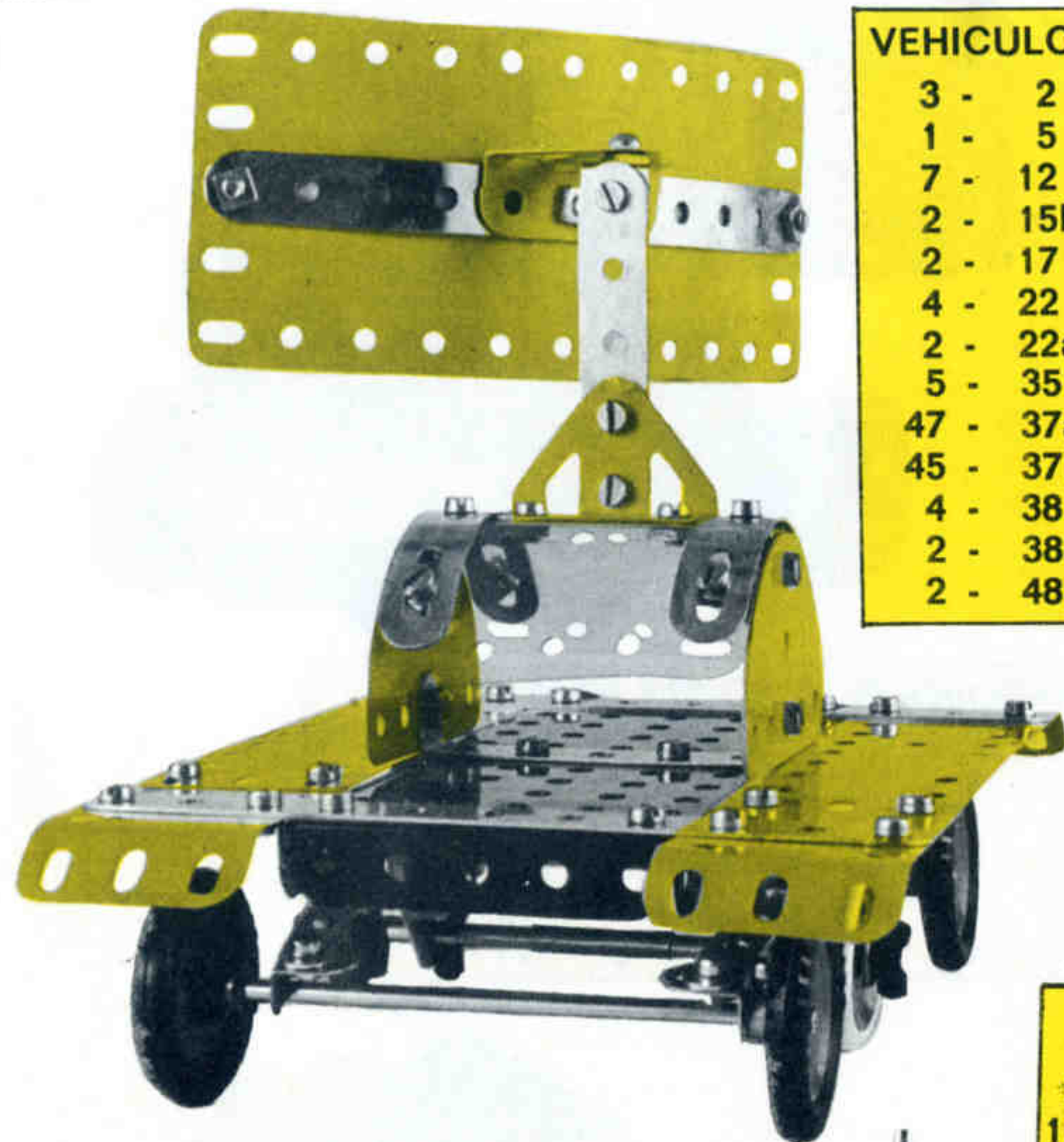

**VEHICULO LUNAR 3/221**

3 - 2	1 - 52
1 - 5	1 - 111c
7 - 12	2 - 126
2 - 15b	2 - 126a
2 - 17	4 - 142c
4 - 22	2 - 155
2 - 22a	2 - 188
5 - 35	2 - 189
47 - 37a	1 - 192
45 - 37b	2 - 193
4 - 38	2 - 214
2 - 38d	2 - 215
2 - 48a	4 - 235a

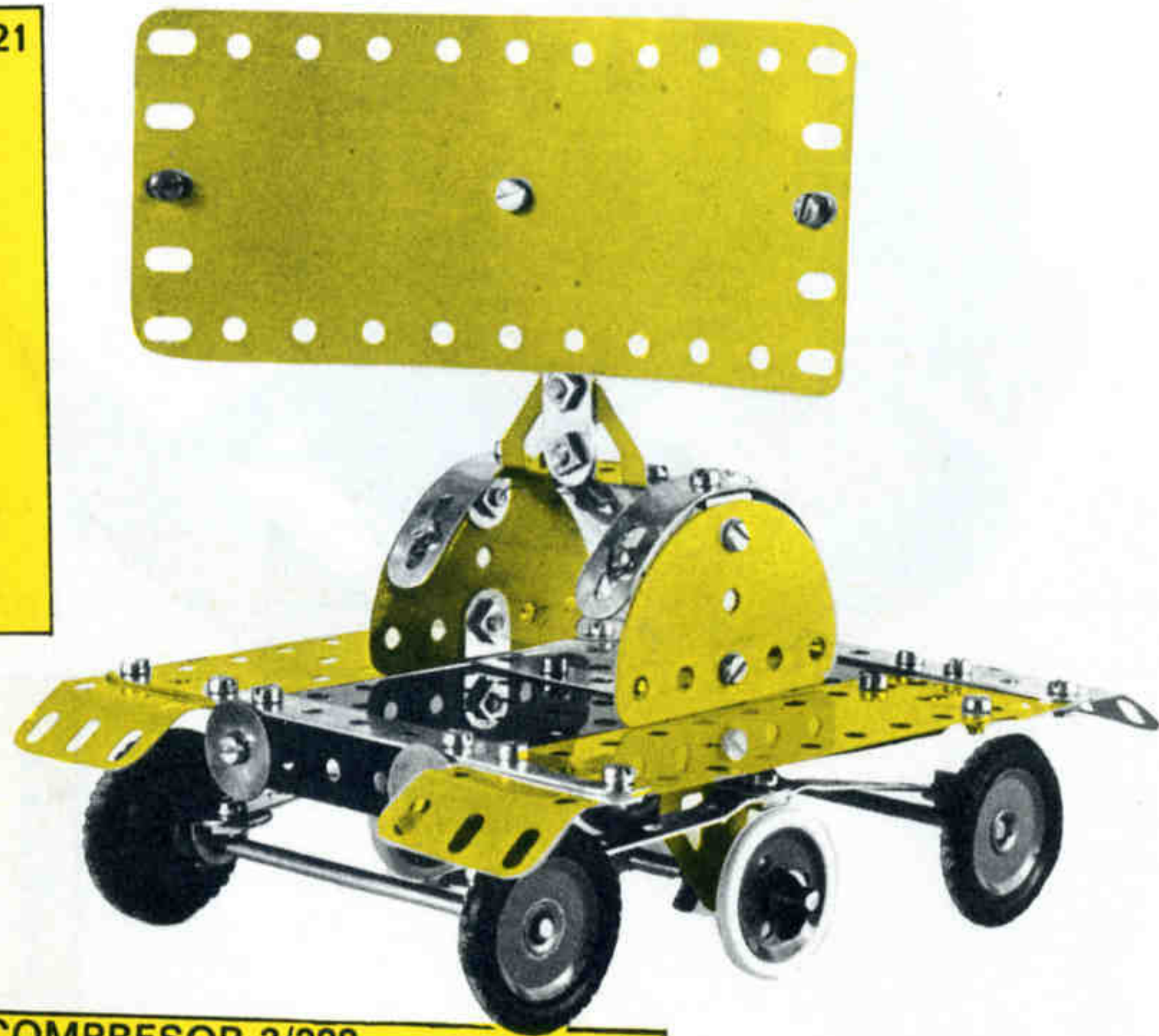

**COMPRESOR 3/222**

1 - 10	1 - 18a	1 - 19g	38 - 37b	2 - 190
2 - 11	1 - 18b	4 - 22	6 - 38	1 - 191
10 - 12	1 - 199	1 - 22a	1 - 40	1 - 192
1 - 15b	1 - 212	1 - 23	2 - 48a	2 - 126a
1 - 20	1 - 213	2 - 24	1 - 52	2 - 142c
1 - 16	2 - 215	6 - 35	2 - 90a	1 - 176
2 - 17	2 - 235b	40 - 37a	1 - 111c	2 - 188

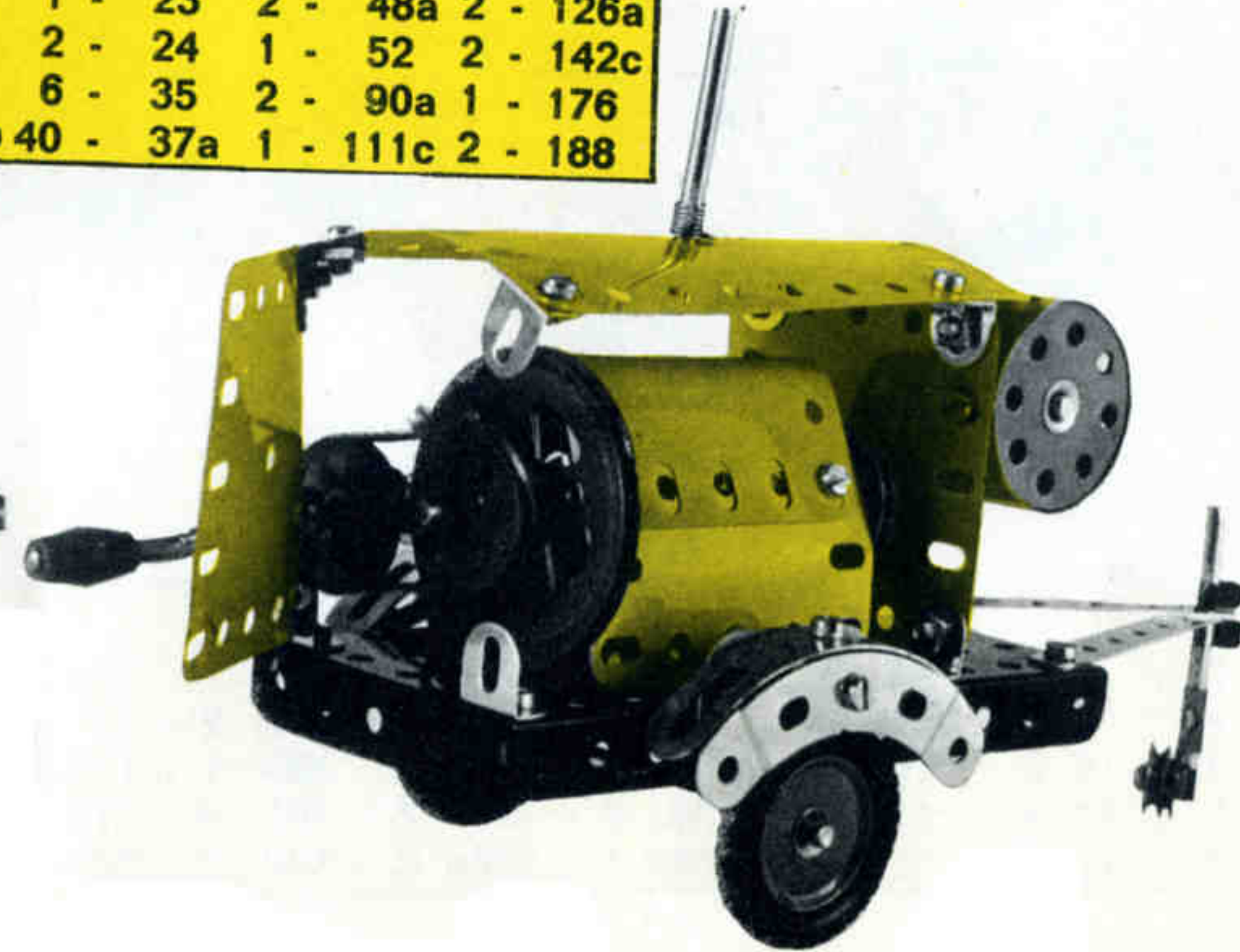
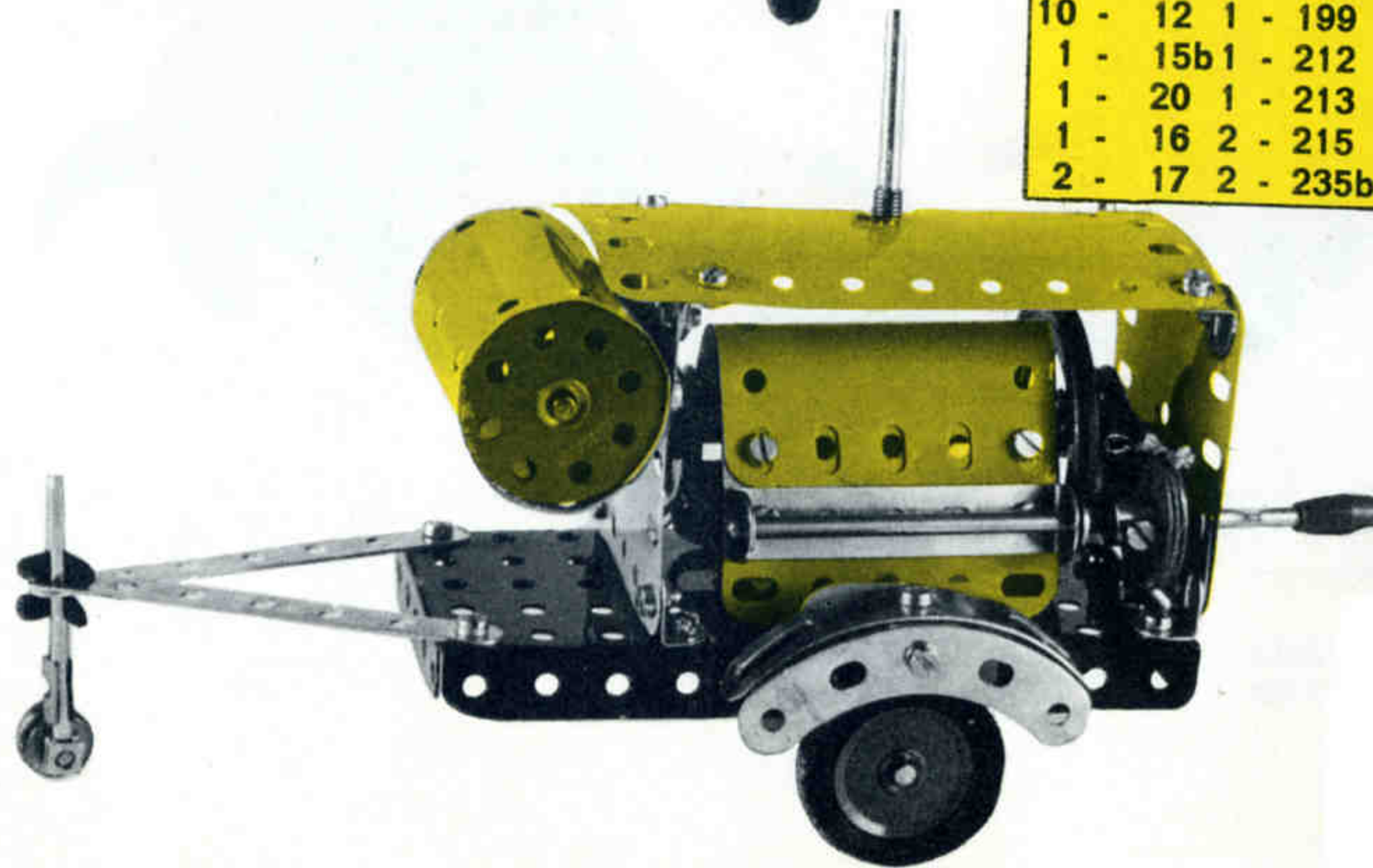



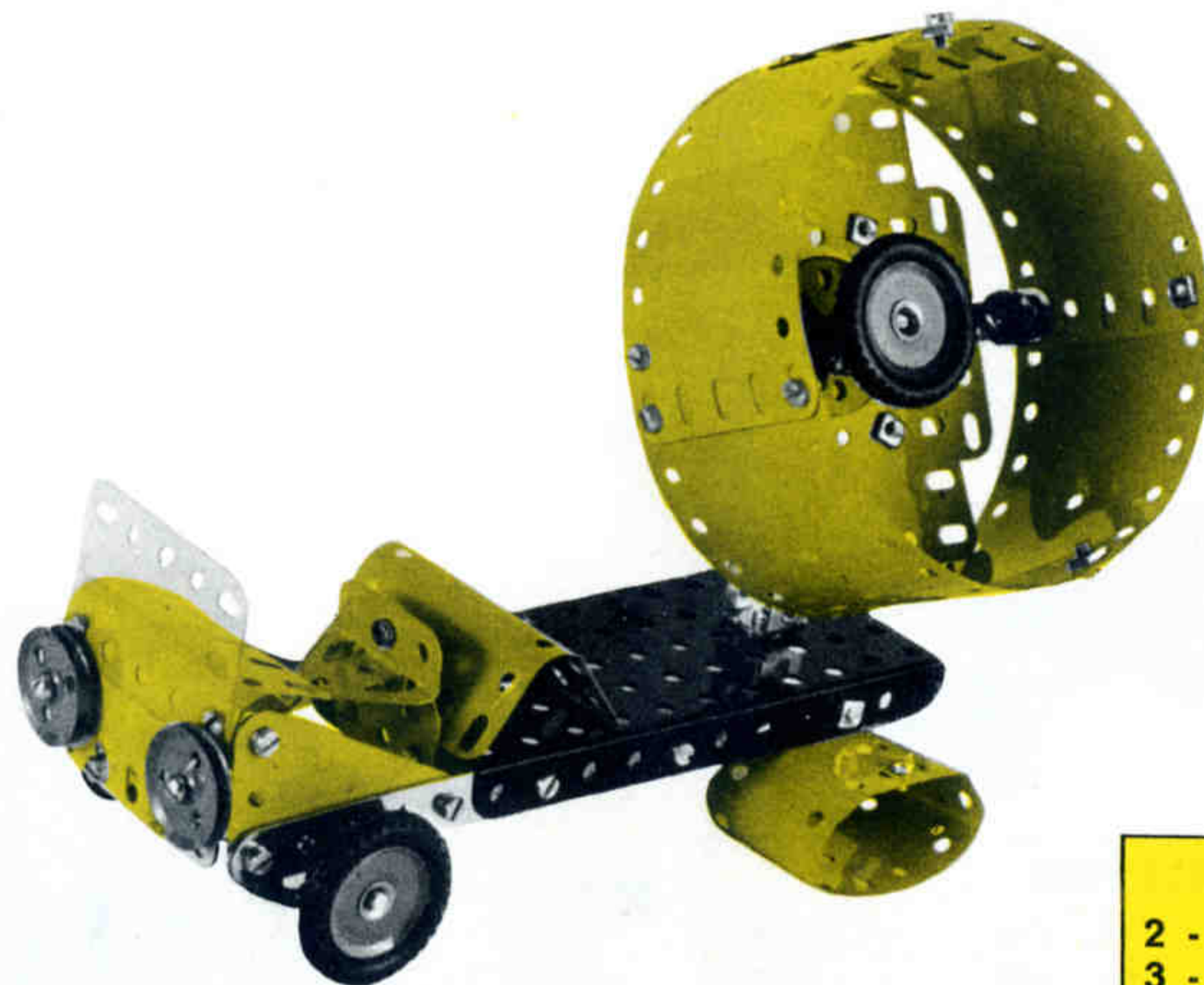

DETECTOR RADIACIONES 3/223					
2 -	2	45 -	37b	2 -	189
1 -	11	6 -	38	2 -	191
9 -	12	2 -	48a	2 -	192
1 -	18a	1 -	52	1 -	193
1 -	16	3 -	111c	1 -	199
3 -	22	1 -	126	1 -	200
2 -	22a	3 -	142c	2 -	221
1 -	24	2 -	188	3 -	235a
51 -	37a	2 -	190	1 -	126a

AVION 3/224							
2 -	1	1 -	22a	2 -	126	1 -	199
3 -	2	2 -	24	1 -	126a	1 -	212
1 -	5	2 -	35	2 -	142c	4 -	221
4 -	10	49 -	37a	1 -	188	4 -	235a
8 -	12	44 -	37b	2 -	189	4 -	235b
2 -	16	1 -	38	2 -	191		
1 -	17	2 -	48a	1 -	192		
2 -	22	3 -	111c	1 -	193		

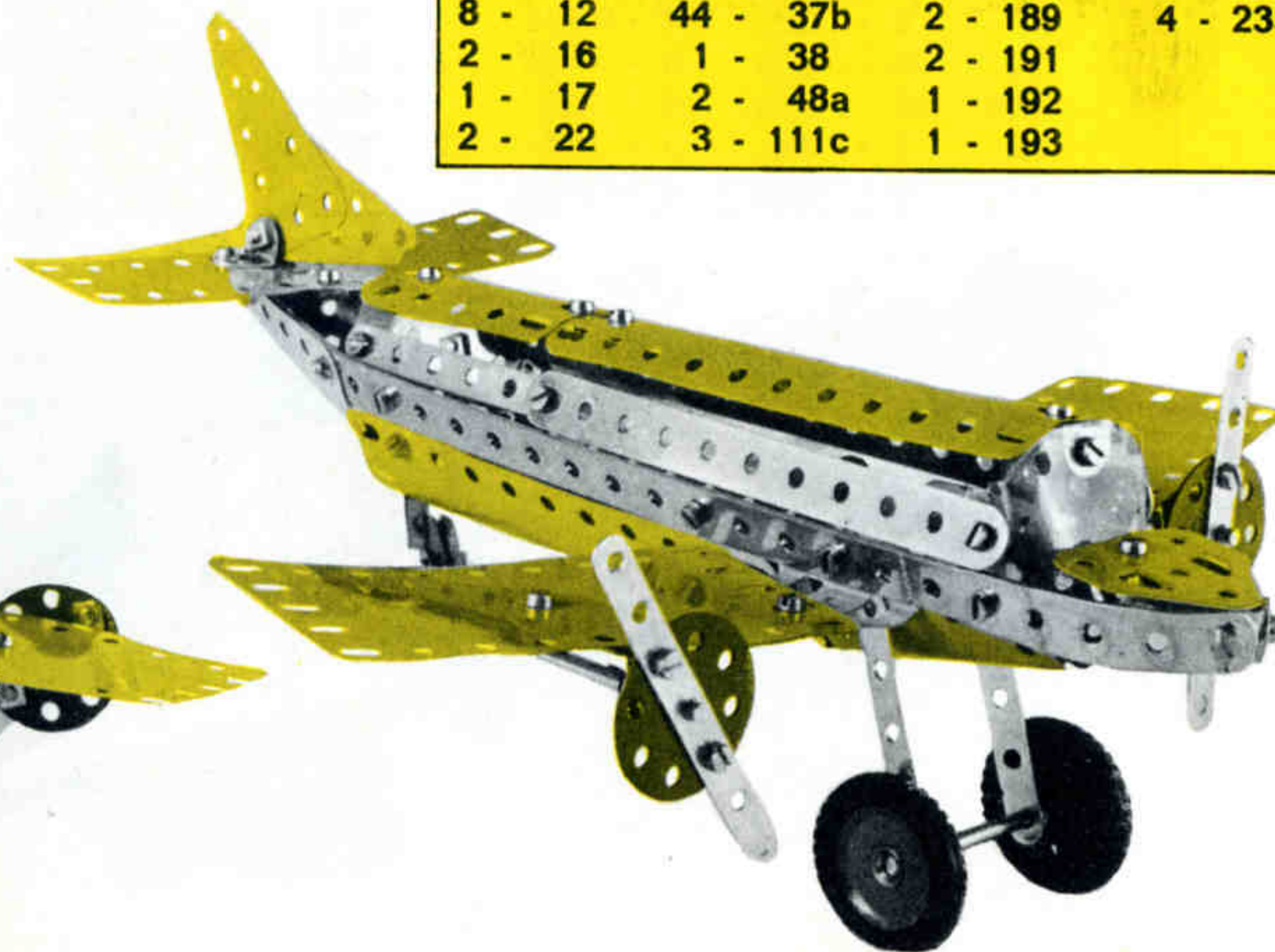

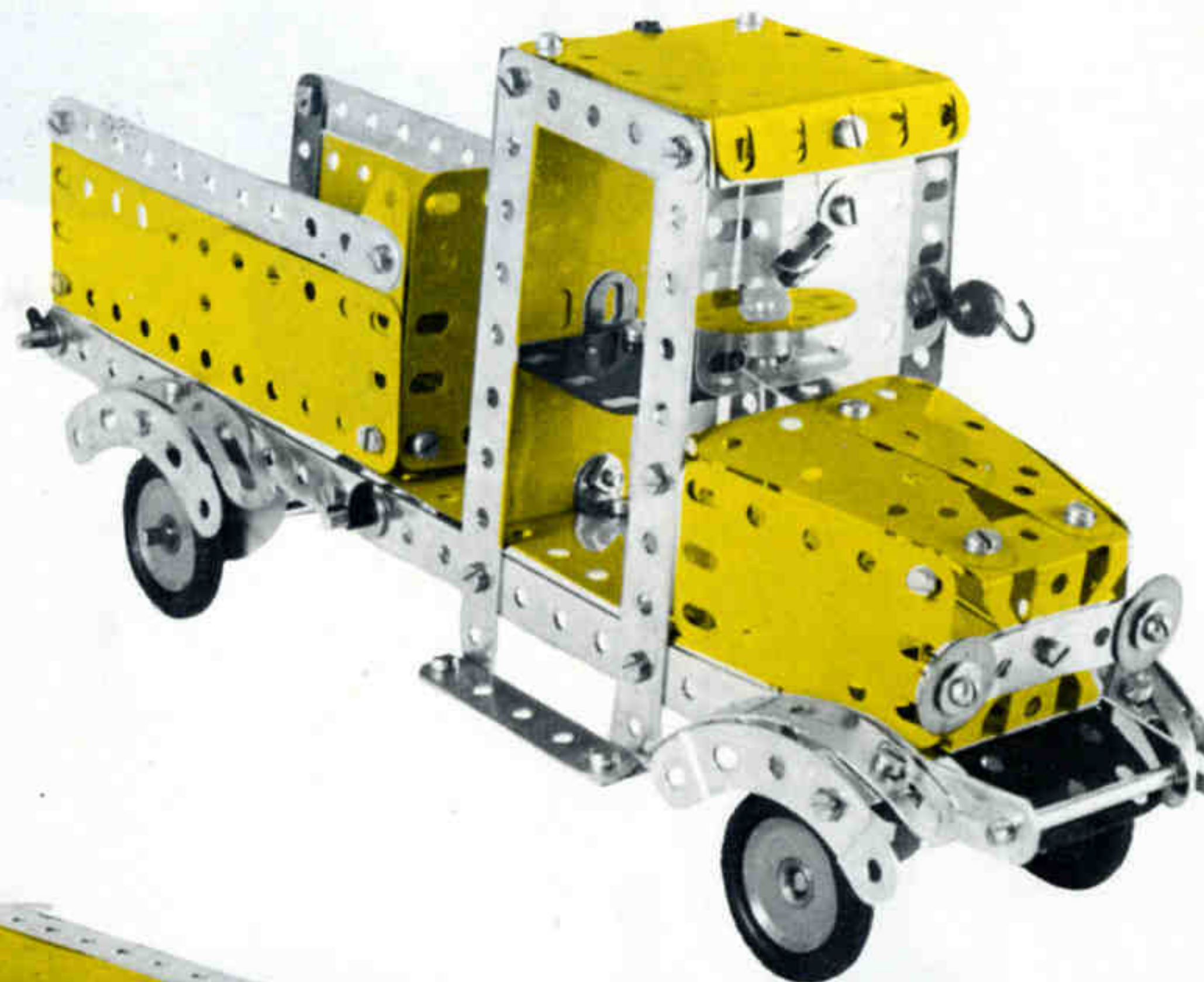
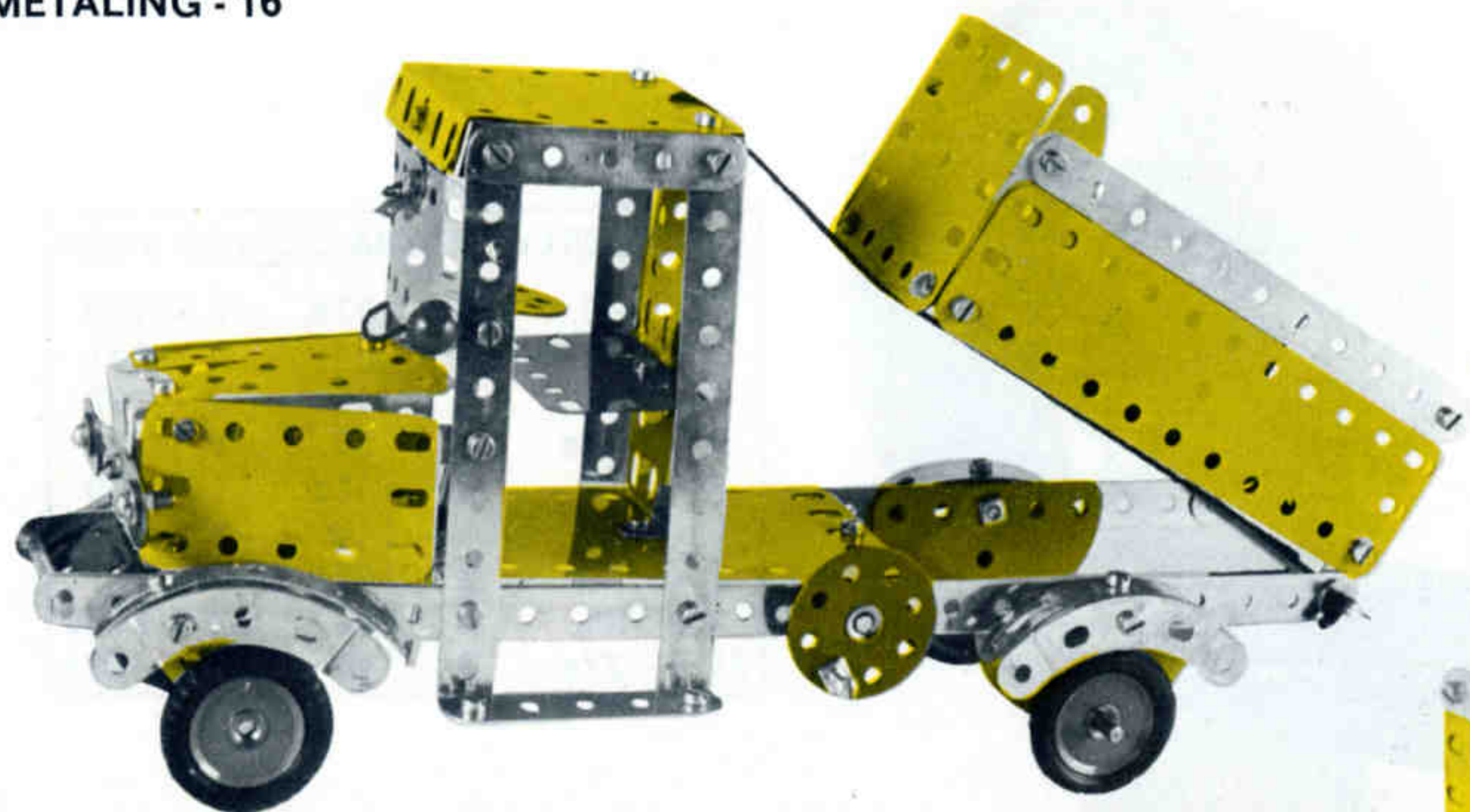

**CAMION VOLQUETE 3/225**

2 - 1	1 - 18a	1 - 40	1 - 176	1 - 212
6 - 2	1 - 18b	2 - 48a	2 - 188	1 - 213
8 - 5	4 - 22	1 - 52	2 - 189	2 - 214
2 - 10	2 - 24	1 - 57c	2 - 190	4 - 215
2 - 11	5 - 35	4 - 90a	1 - 191	4 - 221
10 - 12	60 - 37a	3 - 111c	1 - 192	2 - 235a
1 - 15b	56 - 37b	2 - 126	1 - 193	1 - 235b
3 - 16	5 - 38	2 - 126a	2 - 194	
1 - 17	2 - 38d	4 - 142c		

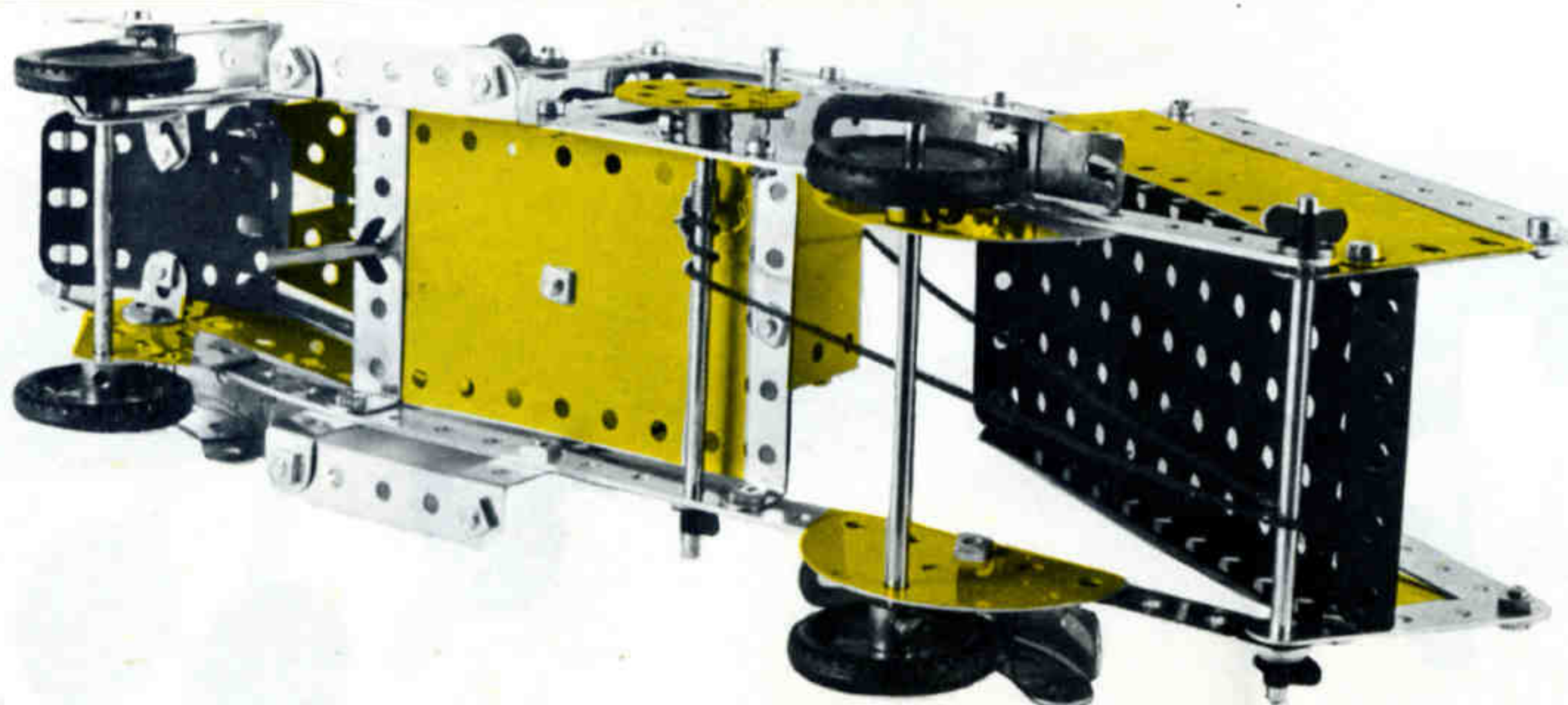

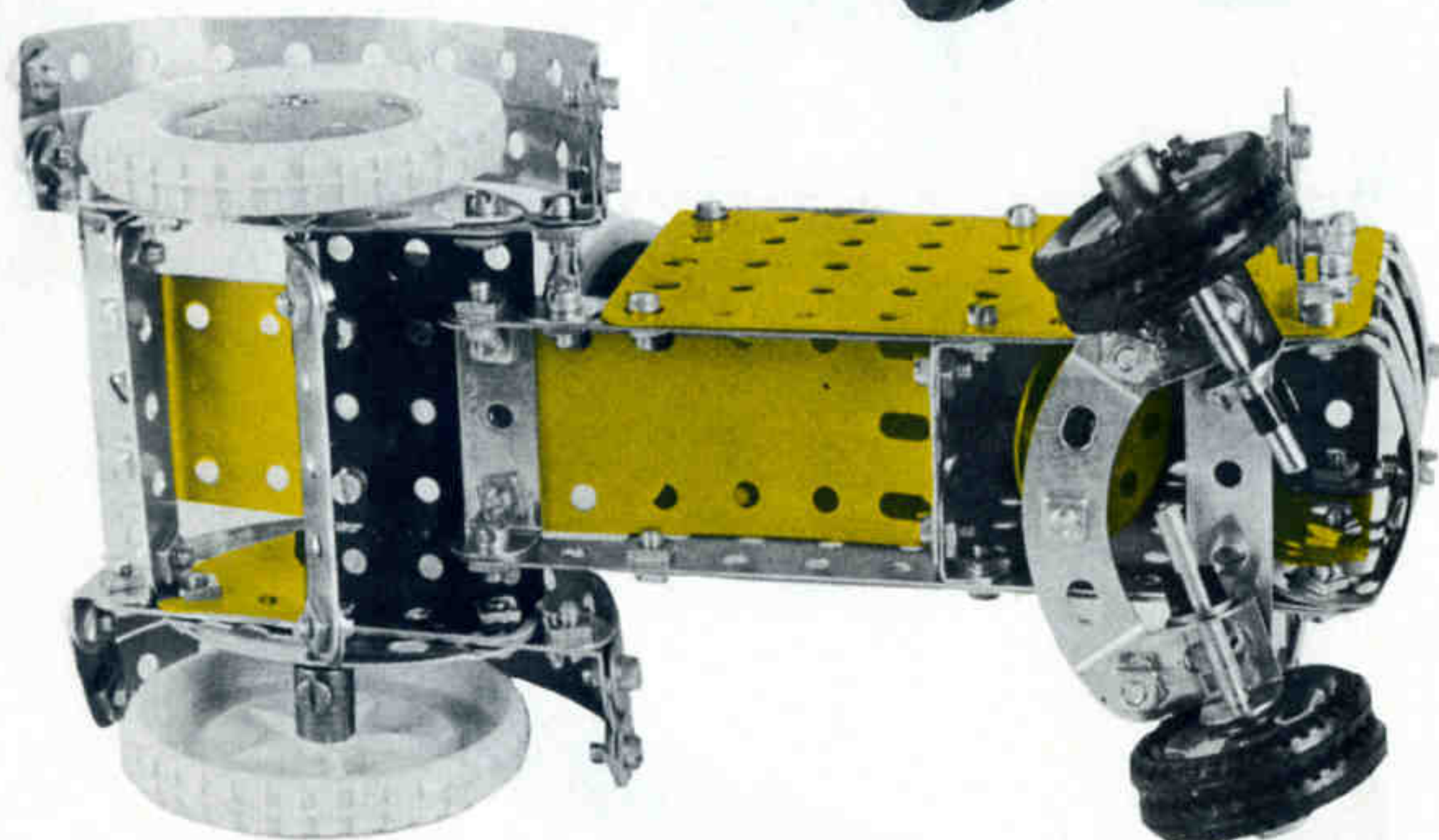
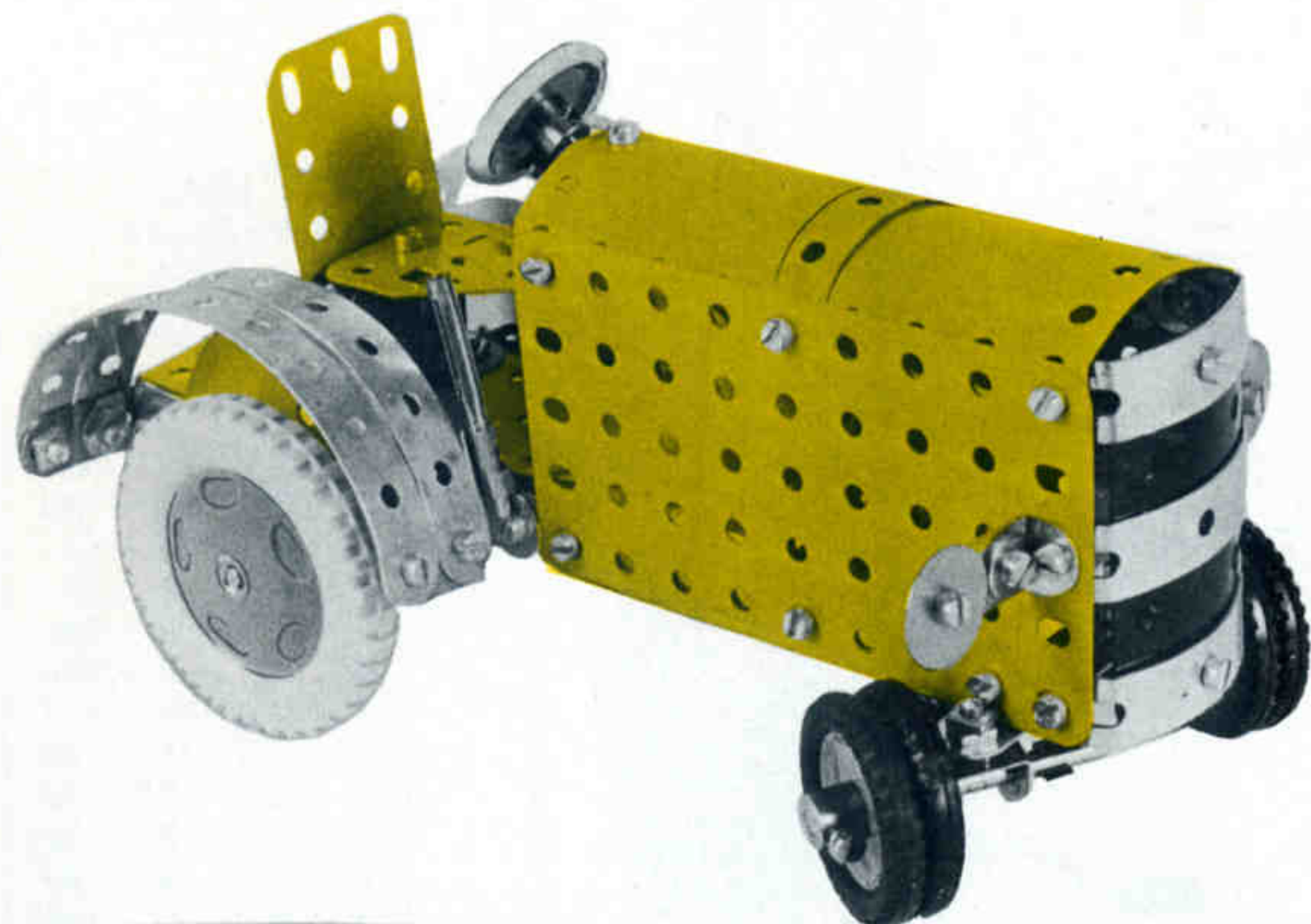

TRACTOR 4/226				
6 - 2	2 - 17	2 - 38d	2 - 126a	1 - 212
2 - 3	1 - 18b	1 - 48	4 - 142c	2 - 212a
2 - 5	2 - 22	1 - 48a	2 - 187	1 - 213
8 - 10	3 - 22a	1 - 51	1 - 155	2 - 214
2 - 11	1 - 24	2 - 53a	1 - 188	3 - 215
1 - 11a	4 - 35	3 - 90a	1 - 189	
4 - 12	72 - 37a	3 - 111c	1 - 194	
1 - 12c	64 - 37b	2 - 125	1 - 199	
1 - 15b	8 - 38	1 - 126	1 - 200	

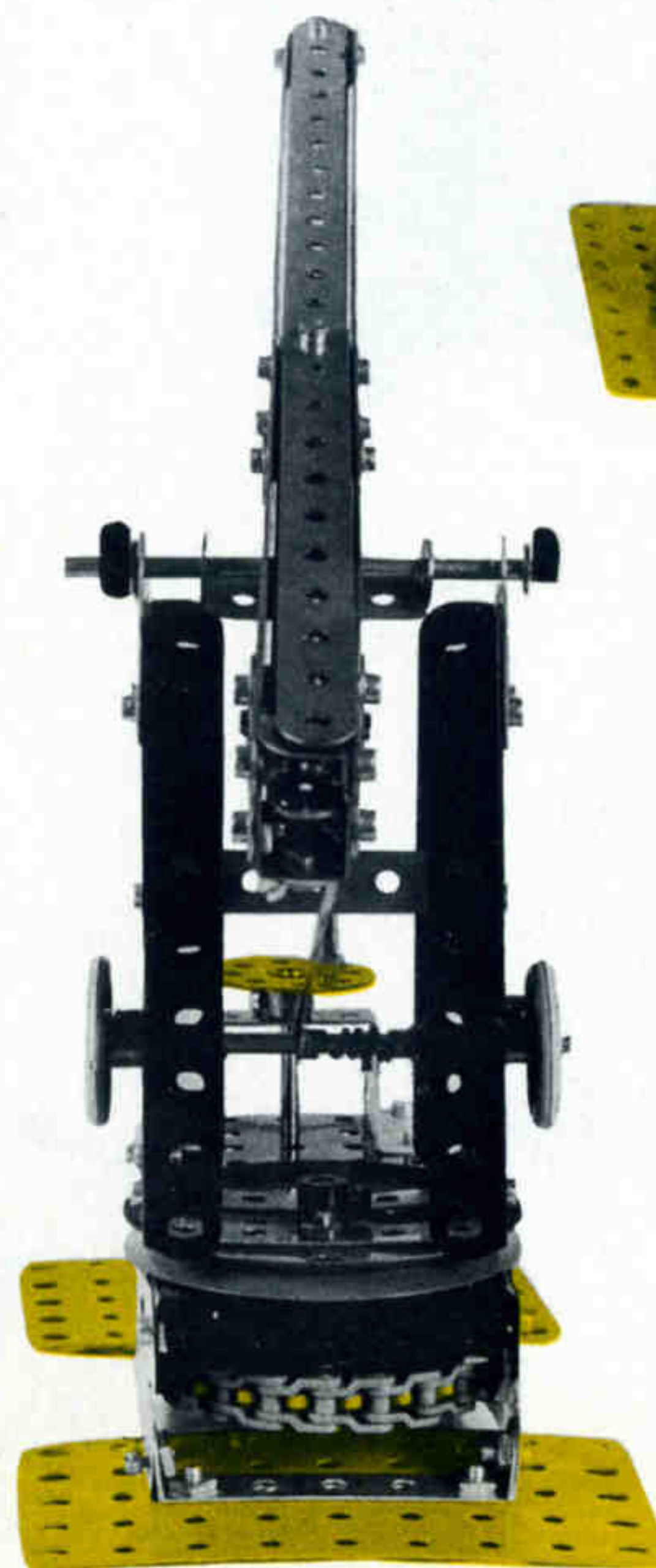

CAÑON DE ARTILLERIA AEREA 4/227	
4 - 1	5 - 48a
3 - 2	1 - 52
1 - 11	2 - 53a
1 - 15b	2 - 54
1 - 16	4 - 90a
1 - 17	1 - 91
1 - 19b	1 - 92
2 - 22a	34 - 93
1 - 24	1 - 111c
2 - 35	2 - 126
52 - 37a	2 - 126a
55 - 37b	2 - 155
2 - 38	1 - 176
1 - 40	2 - 189
2 - 48	1 - 213

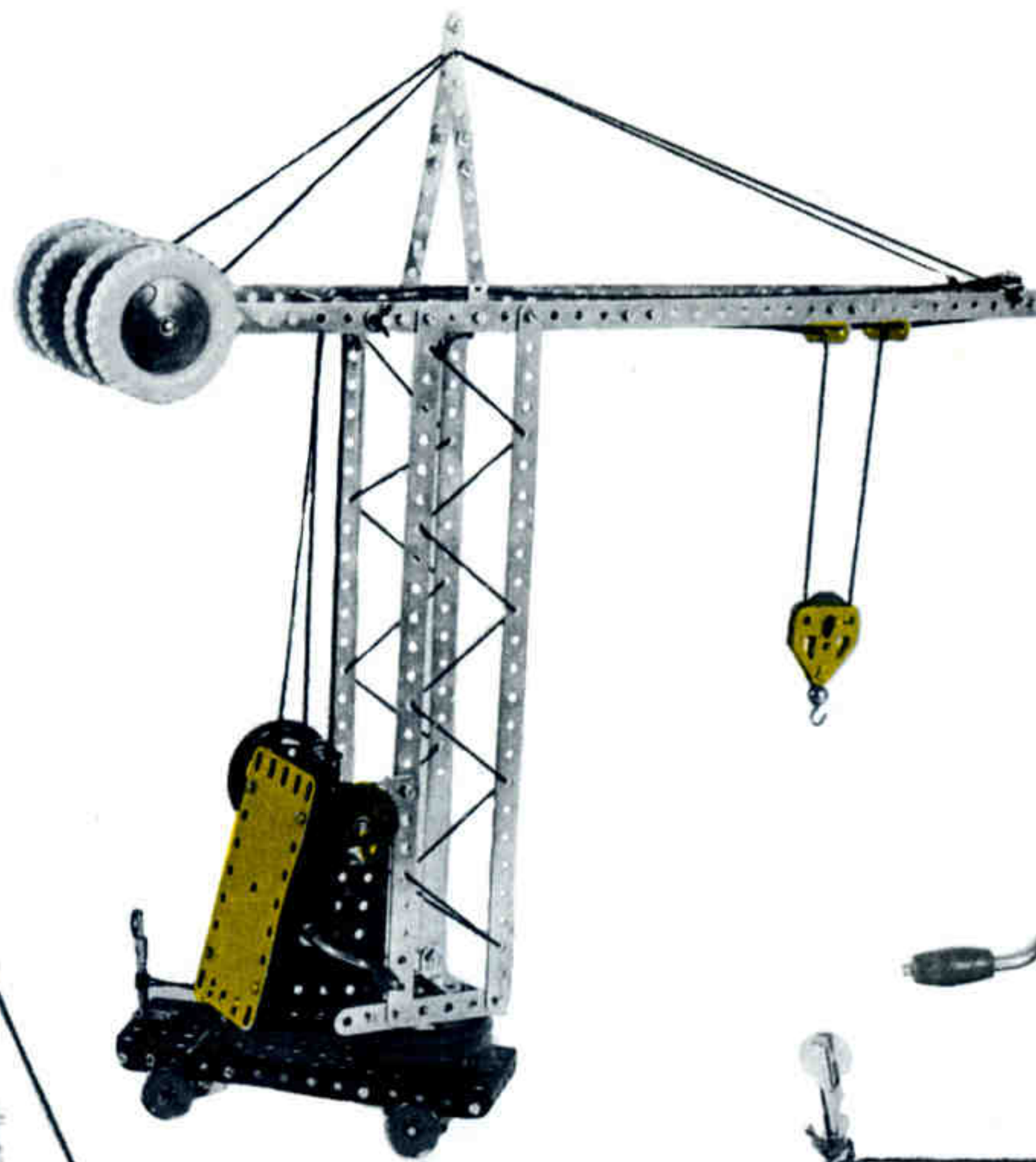

**GRUA  
CONSTRUCCION  
4/228**

4 - 1	59 - 37b
8 - 2	11 - 38
2 - 3	2 - 38d
2 - 5	1 - 48
3 - 10	3 - 48a
2 - 11	1 - 51
1 - 12	1 - 52
1 - 15b	2 - 54
4 - 16	4 - 90a
1 - 18a	51 - 111c
1 - 18b	1 - 125
2 - 19b	2 - 126
1 - 19g	2 - 126a
1 - 20a	4 - 187
4 - 22	1 - 191
1 - 22a	1 - 212
1 - 23	1 - 213
2 - 24	2 - 235a
8 - 35	2 - 235b
68 - 37a	

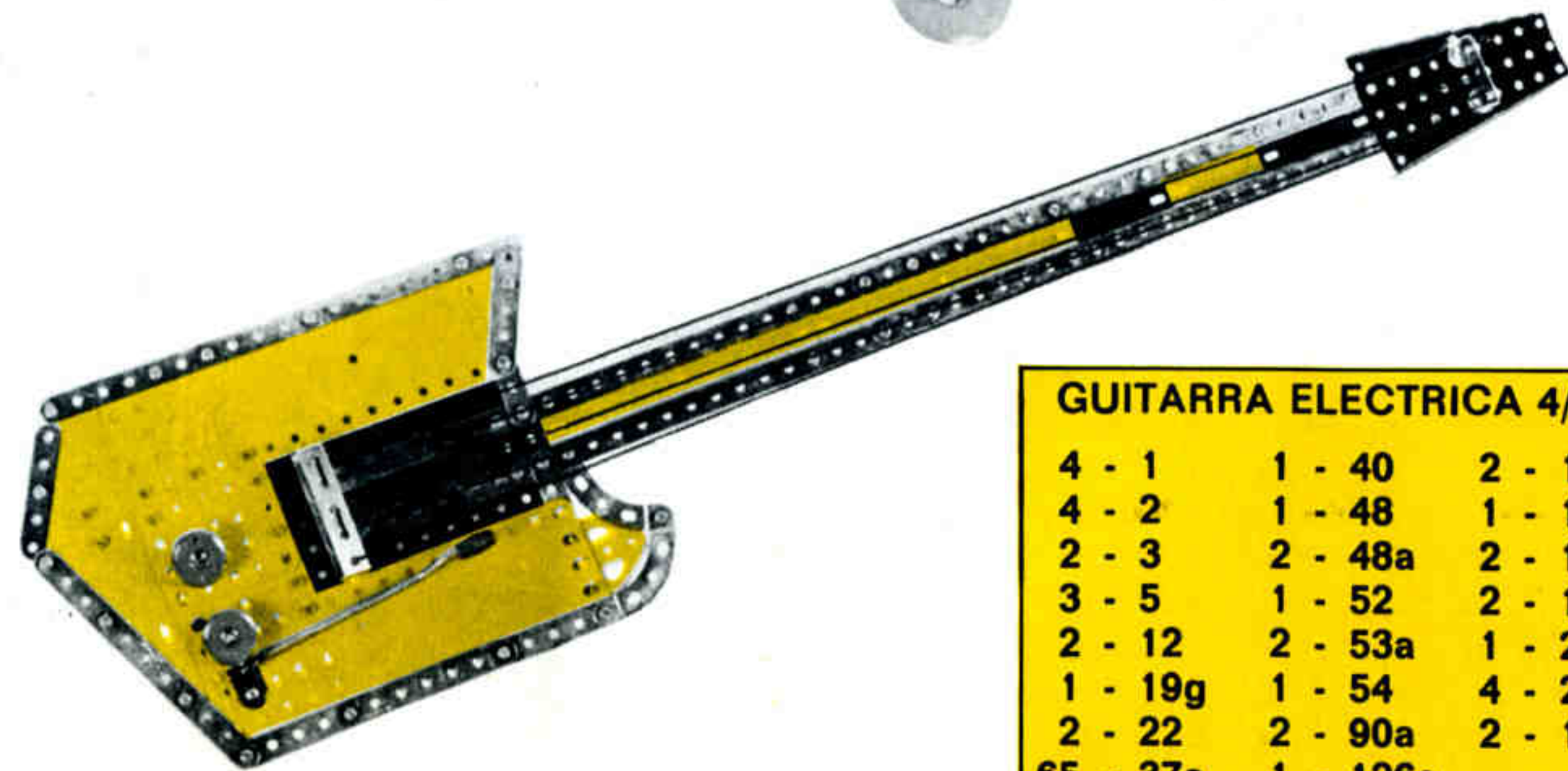
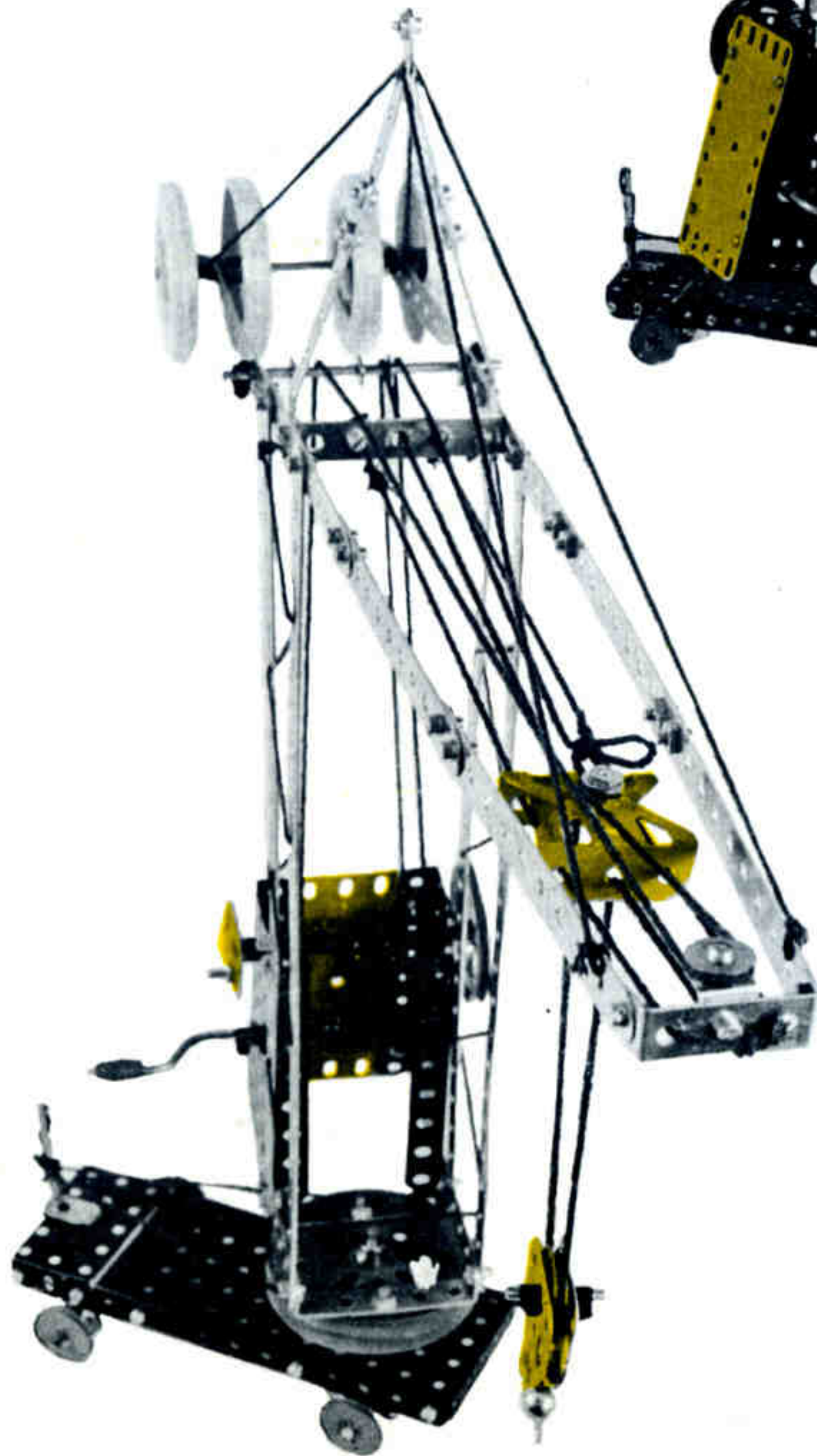
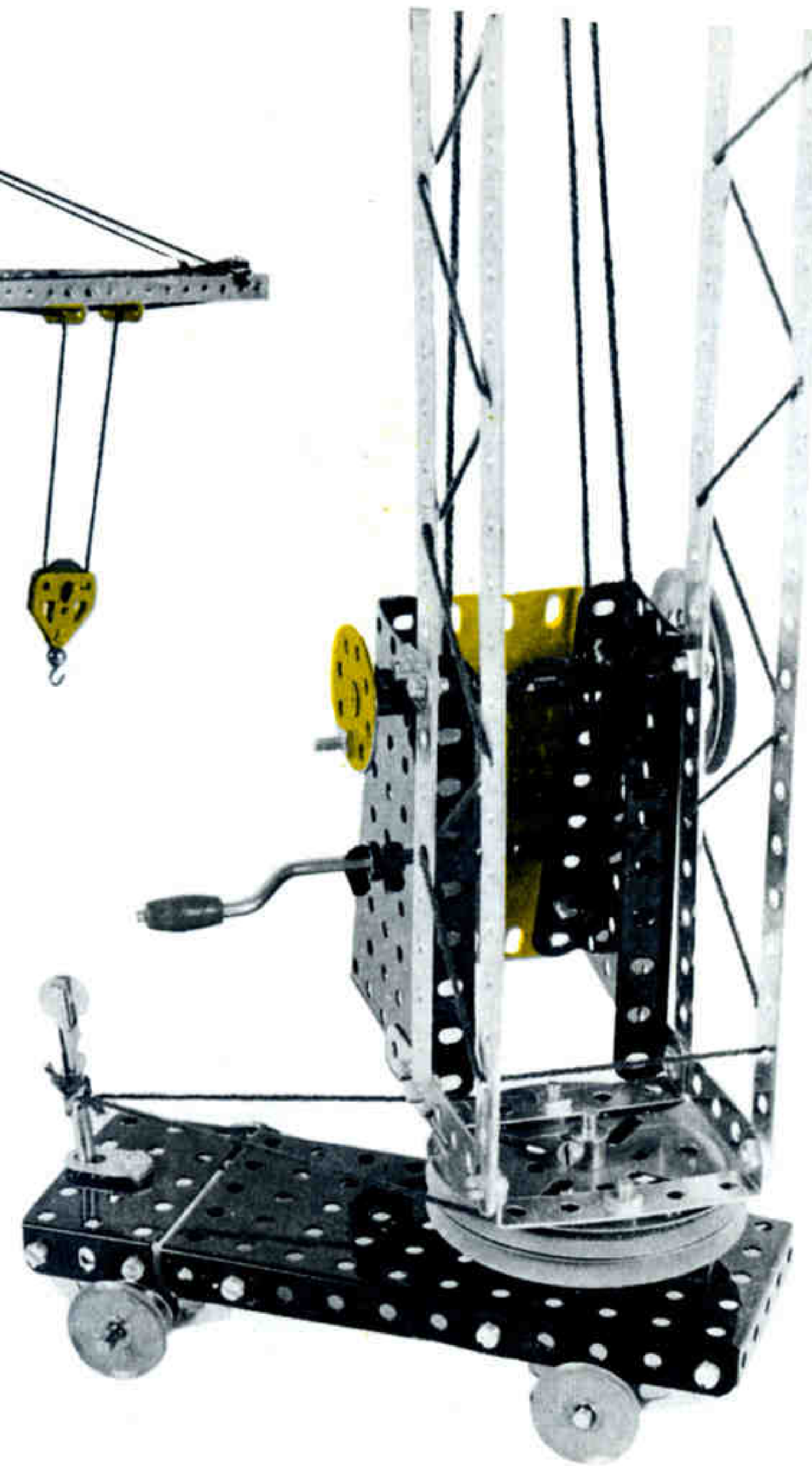

**GUITARRA ELECTRICA 4/229**

4 - 1	1 - 40	2 - 189
4 - 2	1 - 48	1 - 190
2 - 3	2 - 48a	2 - 192
3 - 5	1 - 52	2 - 194
2 - 12	2 - 53a	1 - 212a
1 - 19g	1 - 54	4 - 221
2 - 22	2 - 90a	2 - 111c
65 - 37a	1 - 126a	
65 - 37b	2 - 188	

**LOCOMOTORA**  
4/230

4 - 1	1 - 48
2 - 2	2 - 53a
8 - 5	4 - 90a
10 - 12	1 - 111c
2 - 3	4 - 142c
2 - 11	2 - 189
3 - 16	4 - 190
4 - 22	2 - 191
1 - 23	2 - 192
83 - 37a	2 - 193
82 - 37b	2 - 194a
6 - 48a	2 - 212a
2 - 38d	4 - 235a

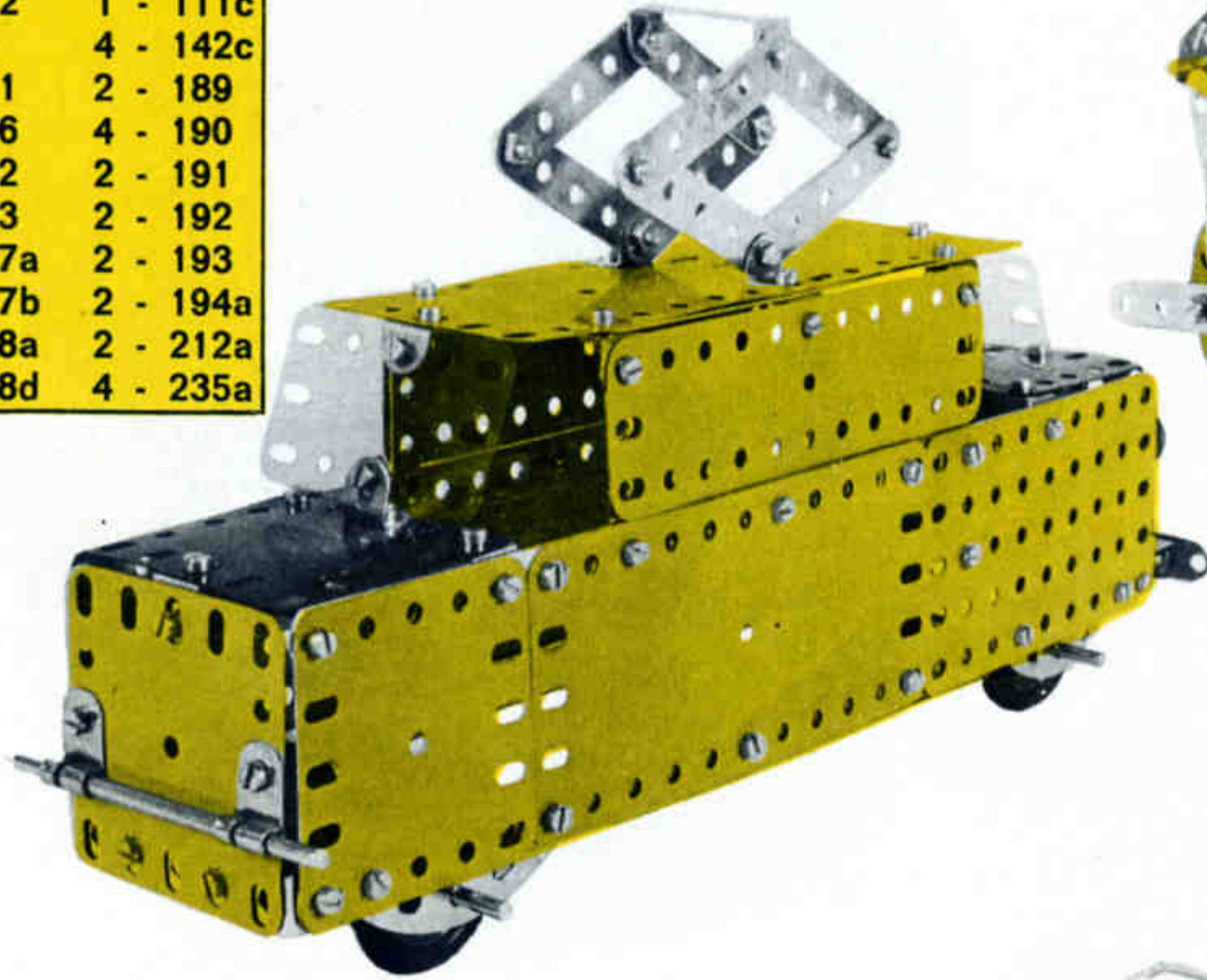

**CAMION PEGASO**  
4/232

5 - 2	70 - 37b	2 - 126a
2 - 3	4 - 38	1 - 155
2 - 11	2 - 38d	4 - 187
8 - 12	1 - 40	2 - 188
2 - 12c	1 - 45	1 - 190
2 - 15b	1 - 48	2 - 191
2 - 17	4 - 48a	2 - 193
1 - 20a	1 - 52	1 - 193a
1 - 22a	1 - 53a	1 - 194
1 - 24	1 - 111a	4 - 215
4 - 35	1 - 111c	2 - 235a
65 - 37a	1 - 126	3 - 235b

**AVION 4/231**

4 - 1	72 - 37a	2 - 142c
5 - 2	68 - 37b	2 - 188
1 - 10	3 - 38	1 - 189
8 - 12	2 - 48a	4 - 190
2 - 22	2 - 111c	2 - 191
1 - 24	2 - 126	2 - 192
1 - 194	1 - 214	4 - 235a
1 - 199	2 - 221	2 - 235b

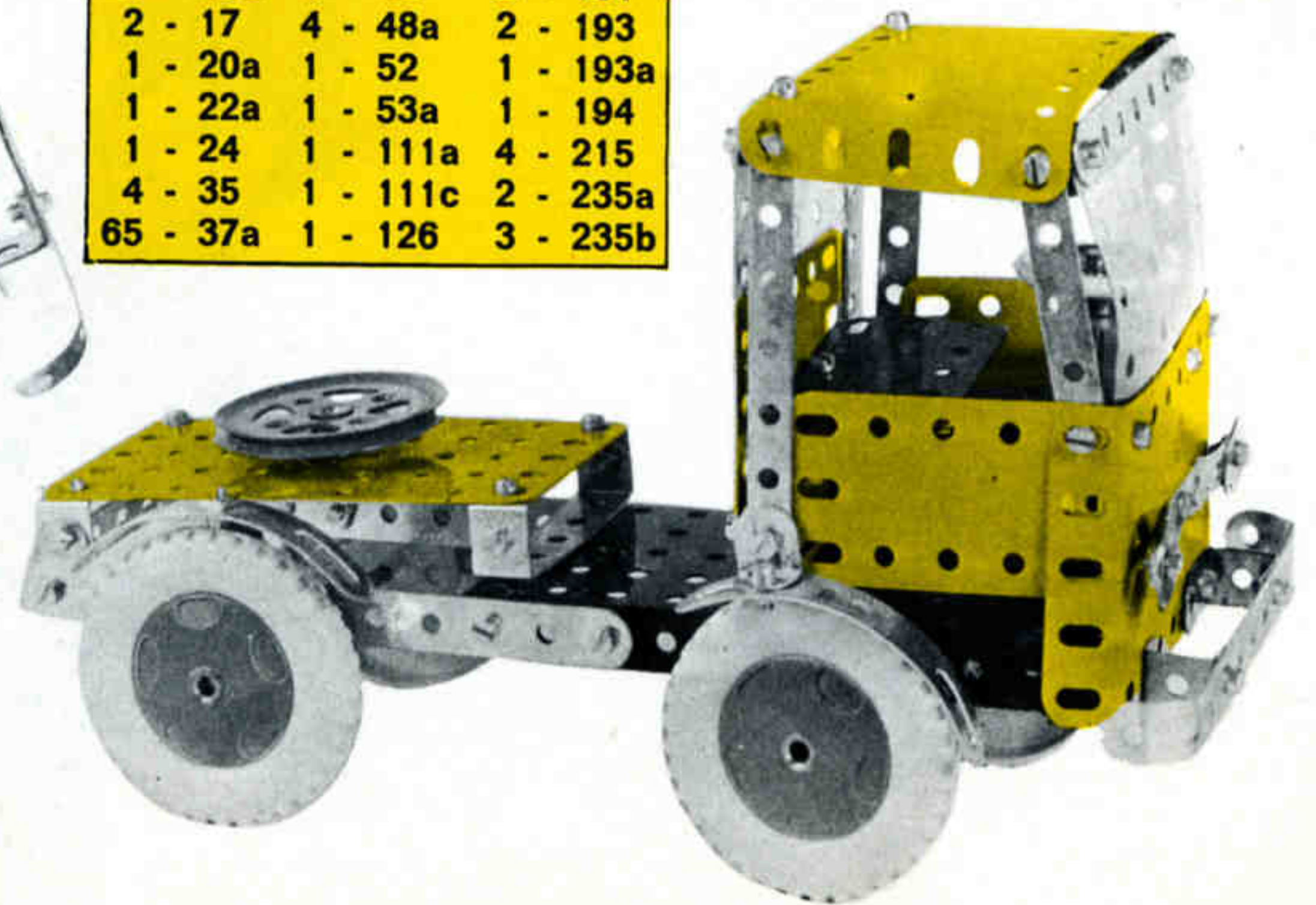
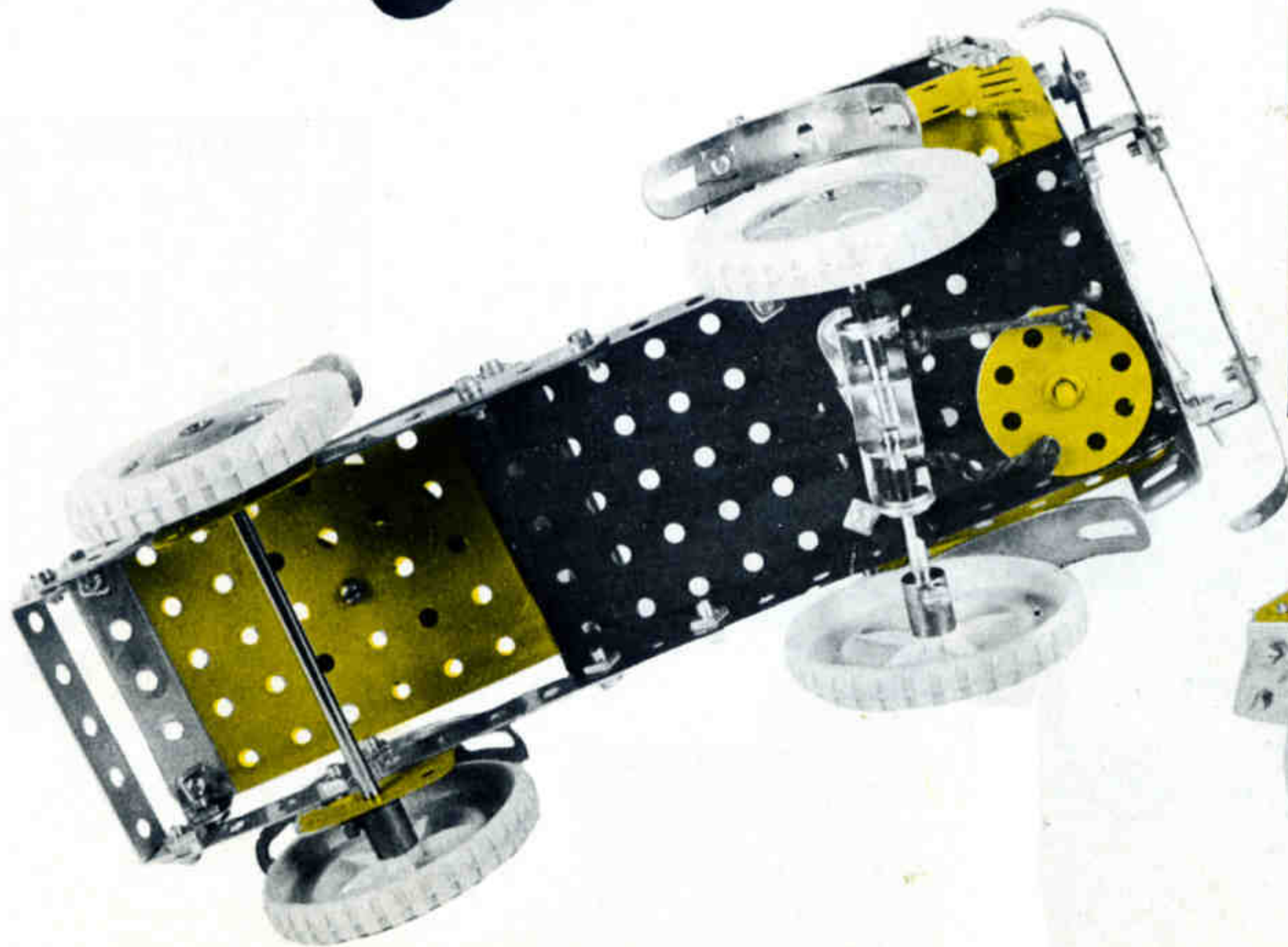

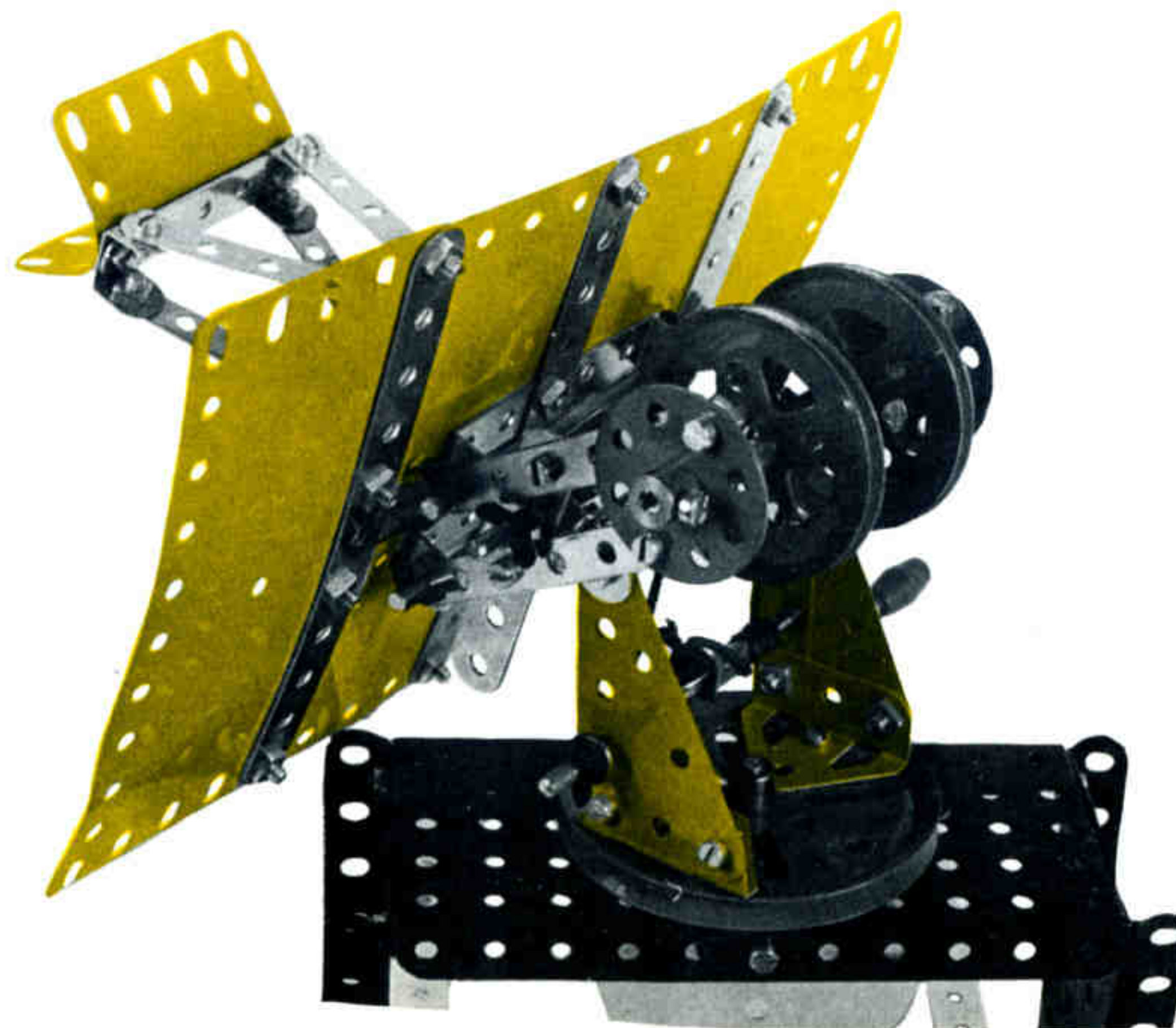
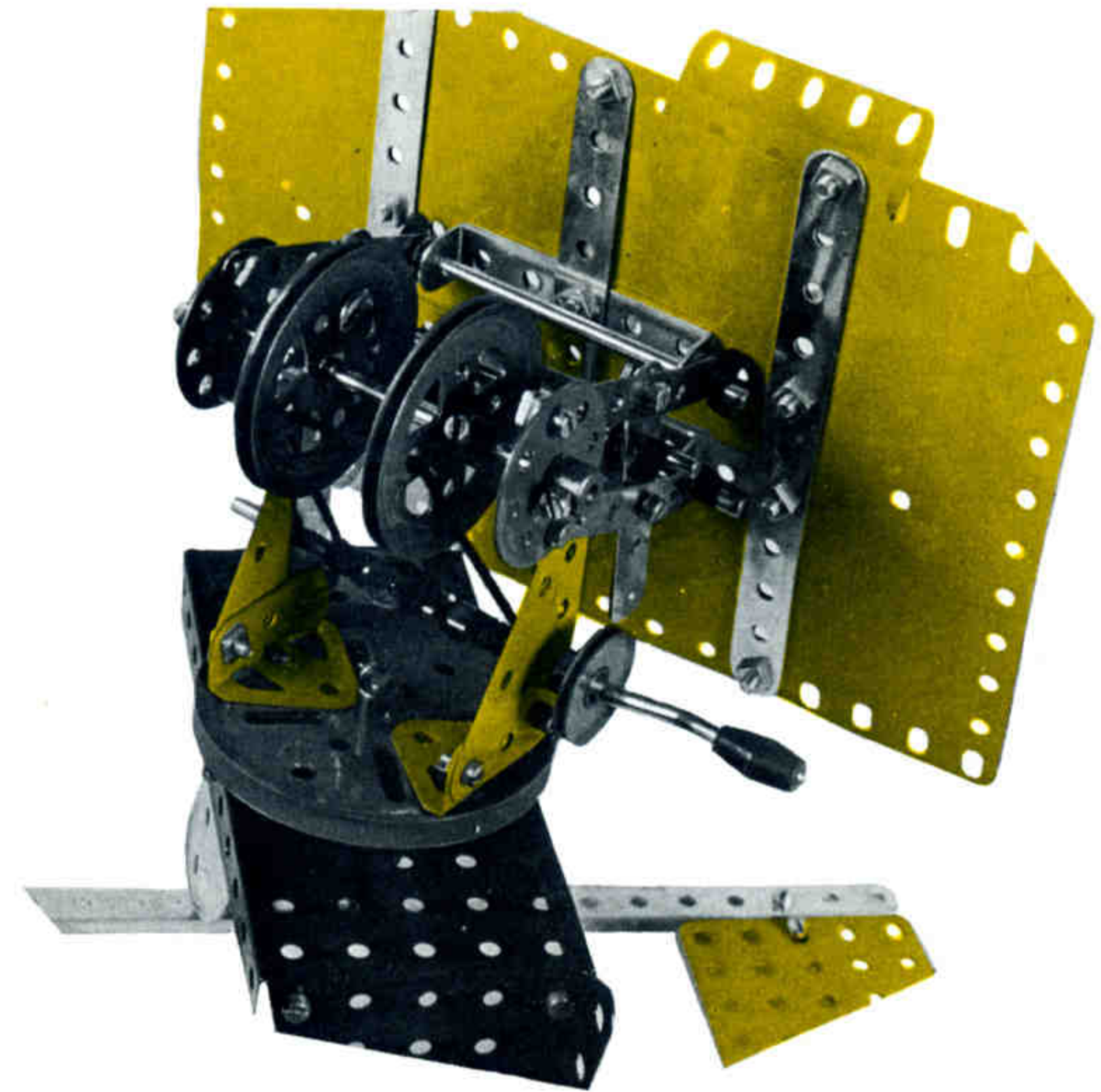
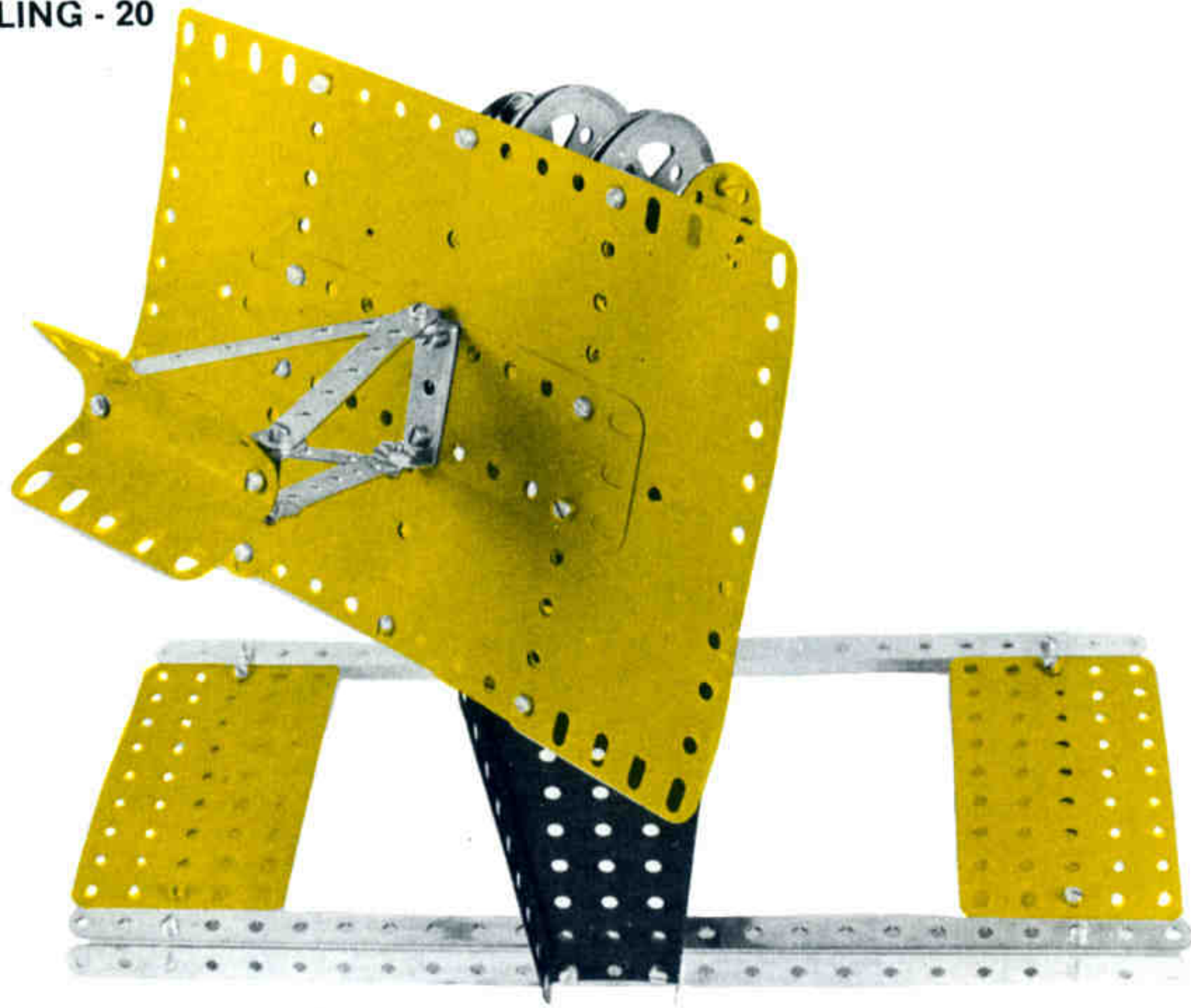

RADAR 4/233	
4 - 1	10 - 38
5 - 2	1 - 38d
1 - 11a	1 - 40
2 - 12	1 - 52
1 - 15d	2 - 53a
2 - 16	2 - 54
1 - 19b	2 - 126
1 - 19g	1 - 189
2 - 20a	4 - 192
1 - 22	1 - 199
2 - 24	2 - 214
8 - 35	2 - 221
67 - 37a	4 - 235a
67 - 37b	4 - 235b

**BARCO PIRATA**  
4/234

4 - 1	35 - 37a
6 - 2	35 - 37b
2 - 3	1 - 40
6 - 5	4 - 48a
2 - 12	2 - 90a
3 - 12c	2 - 235b

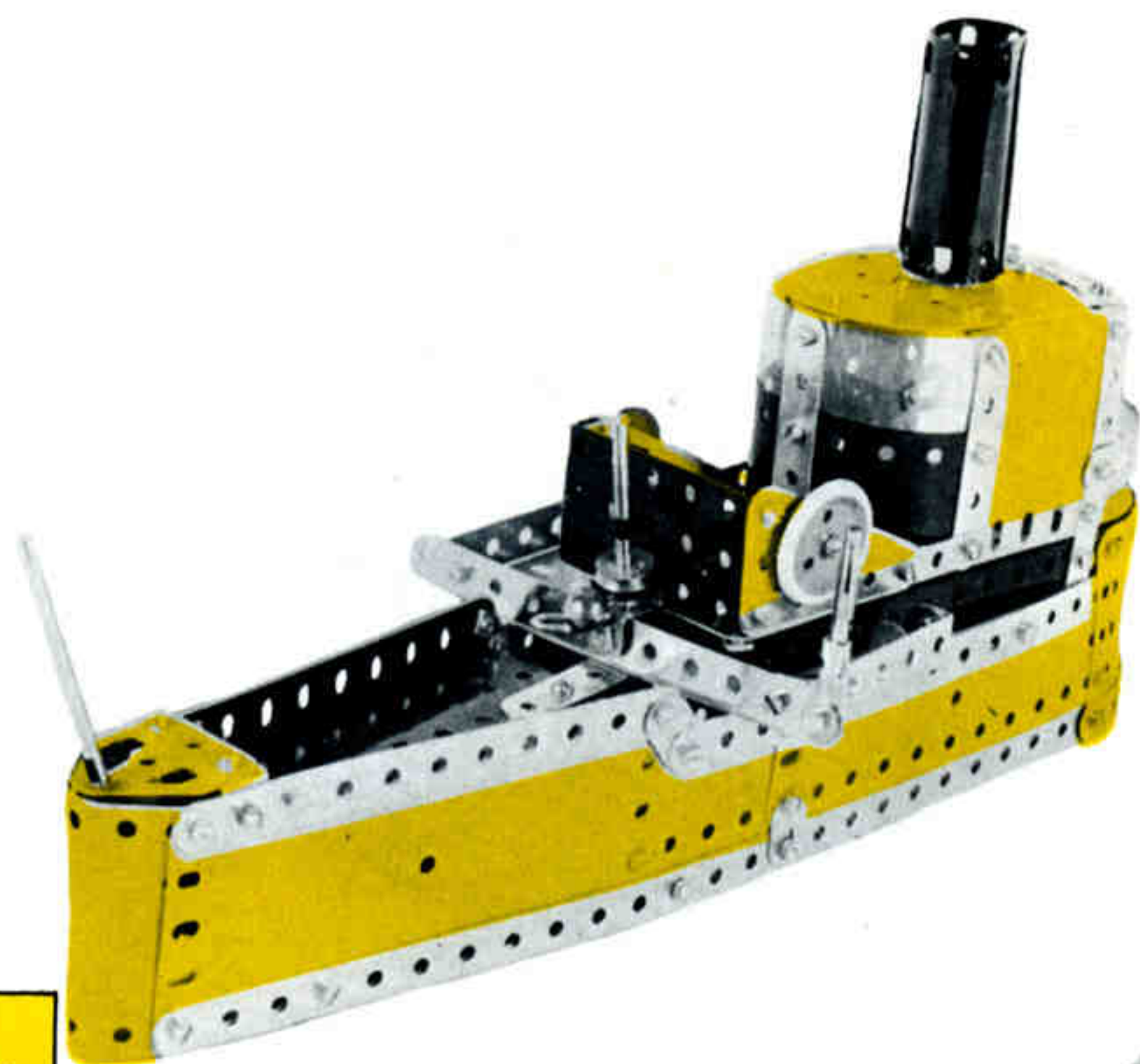
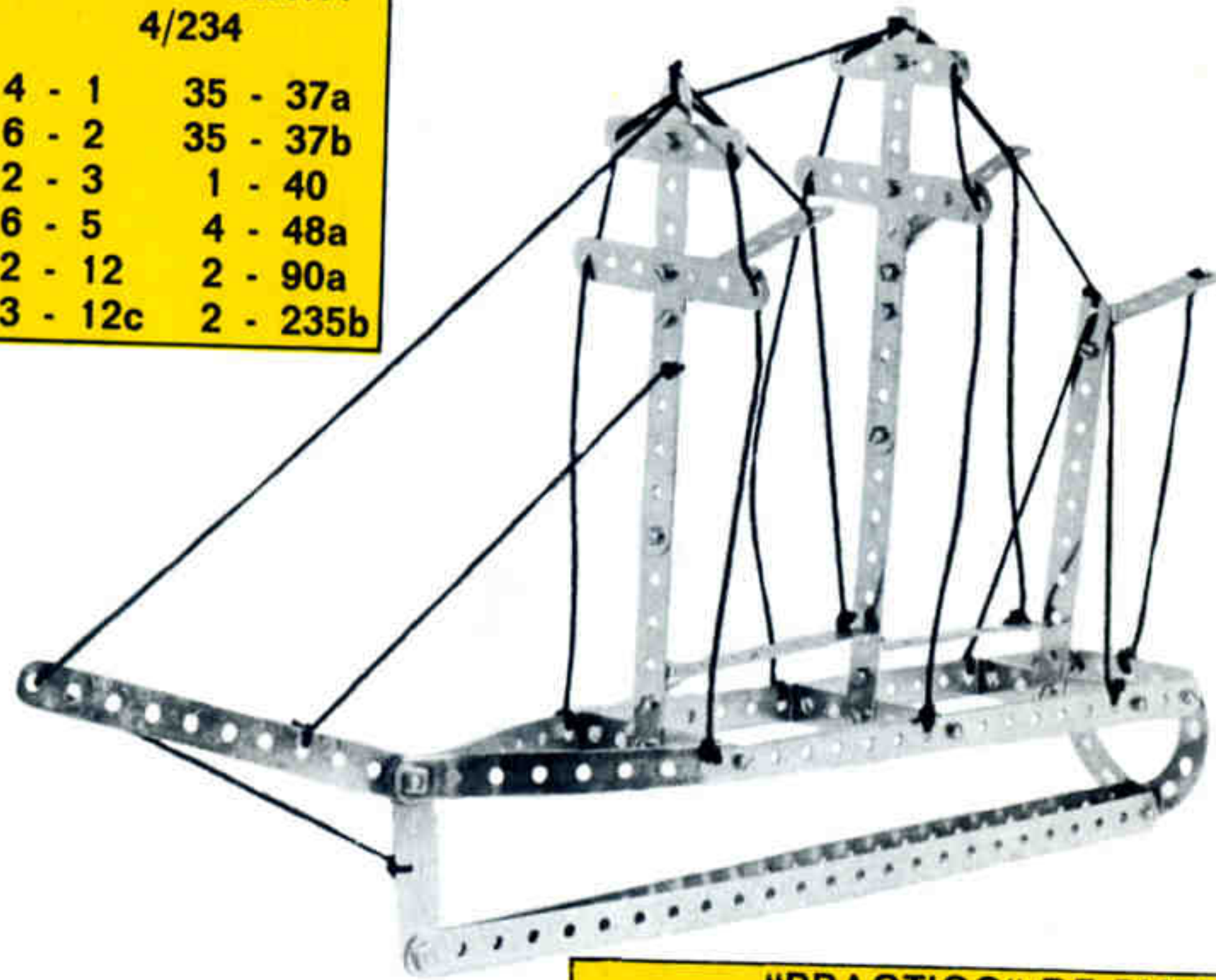

**"PRACTICO" DE PUERTO 4/235**

2 - 1	2 - 22a	1 - 51	1 - 126a	2 - 194a
5 - 2	1 - 23	1 - 52	2 - 155	1 - 199
6 - 5	6 - 35	1 - 53a	2 - 189	1 - 212
4 - 10	95 - 37a	2 - 54	2 - 188	2 - 214
2 - 11	97 - 37b	1 - 57c	4 - 190	2 - 215
8 - 12	1 - 38	1 - 90a	1 - 190a	2 - 221
2 - 15b	1 - 48	3 - 111c	2 - 192	4 - 235b
1 - 18b	5 - 48a	1 - 125	1 - 193b	

**YATE 4/236**

3 - 1	1 - 48	2 - 192
4 - 2	2 - 48a	2 - 193
2 - 3	1 - 52	2 - 193a
3 - 5	2 - 53a	2 - 194
1 - 10	1 - 54	1 - 212
7 - 12	2 - 90a	2 - 212a
2 - 12c	3 - 111c	1 - 214
1 - 15b	2 - 125	4 - 215
2 - 16	1 - 126a	4 - 221
1 - 18a	1 - 176	2 - 235a
3 - 35	2 - 188	2 - 235b
72 - 37a	2 - 189	
69 - 37b	4 - 190	

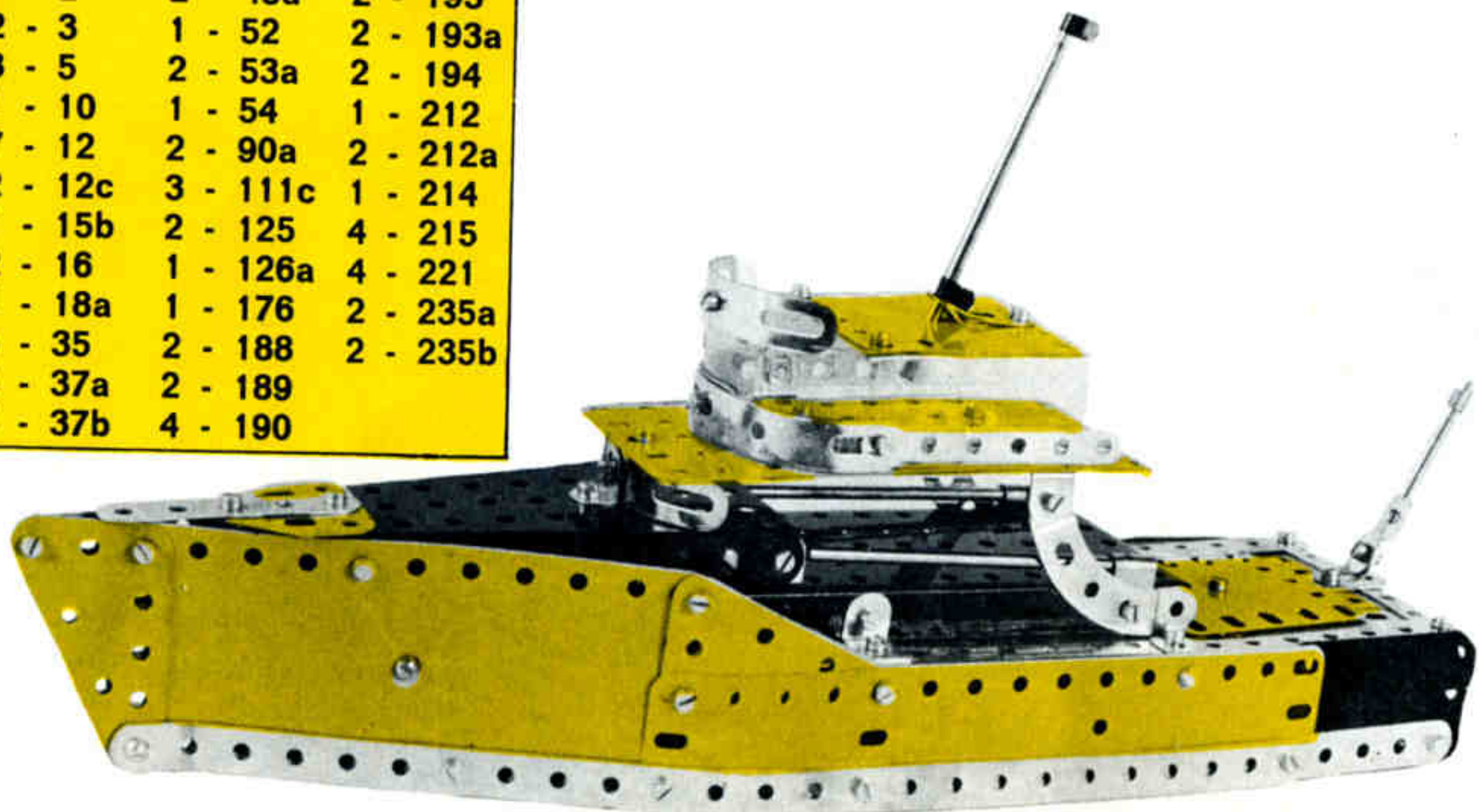

**ATALAYA 4/237**

4 - 1	4 - 48a
8 - 2	1 - 51
2 - 10	1 - 52
1 - 11	2 - 54
3 - 12	1 - 91
1 - 15b	1 - 92
2 - 17	4 - 111c
1 - 18a	1 - 126
1 - 20a	1 - 126a
1 - 22	1 - 142c
2 - 24	2 - 188
6 - 35	2 - 189
2 - 19b	2 - 194
68 - 37a	1 - 214
64 - 37b	4 - 235a
7 - 38	2 - 235b
1 - 48	46 - 374

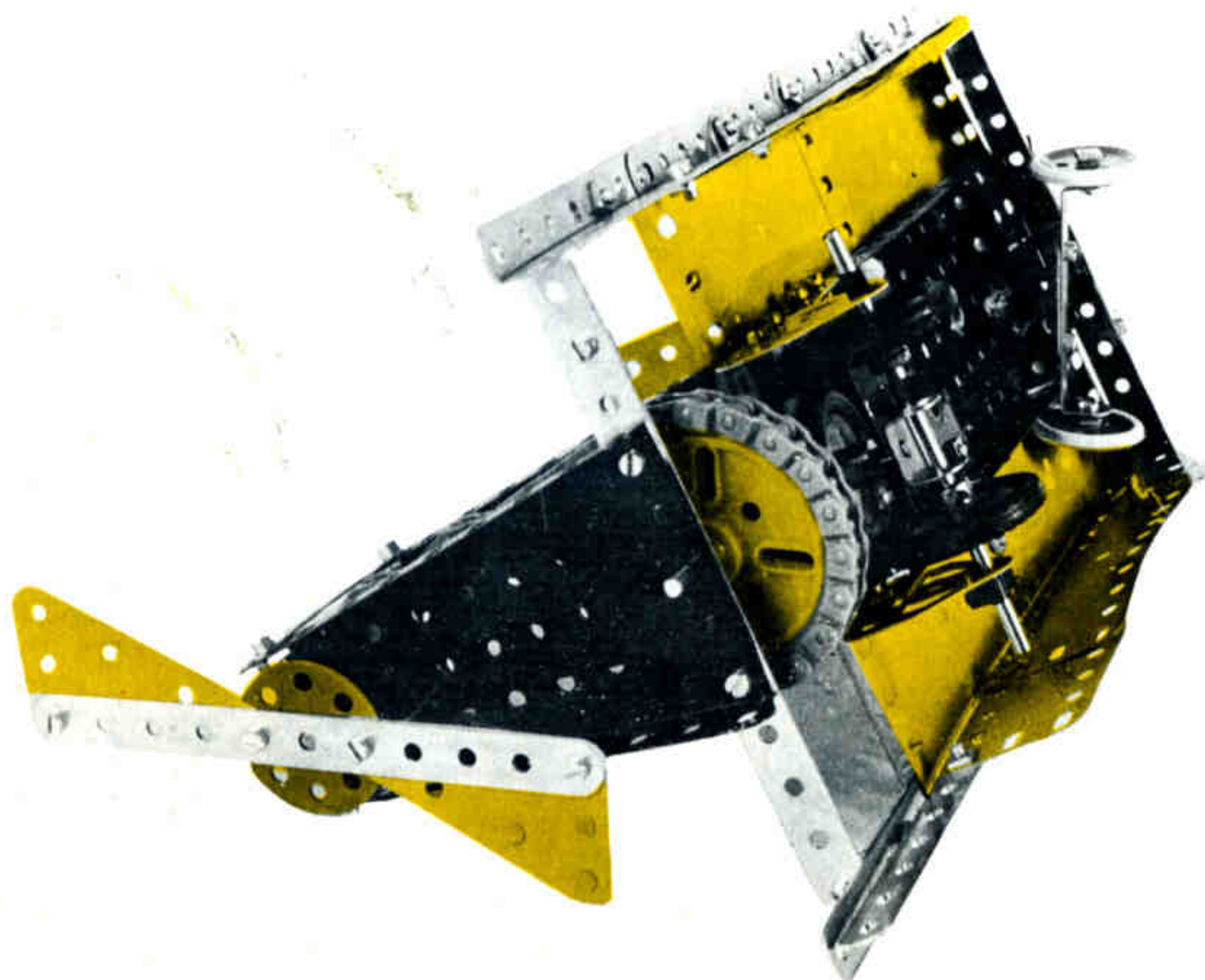
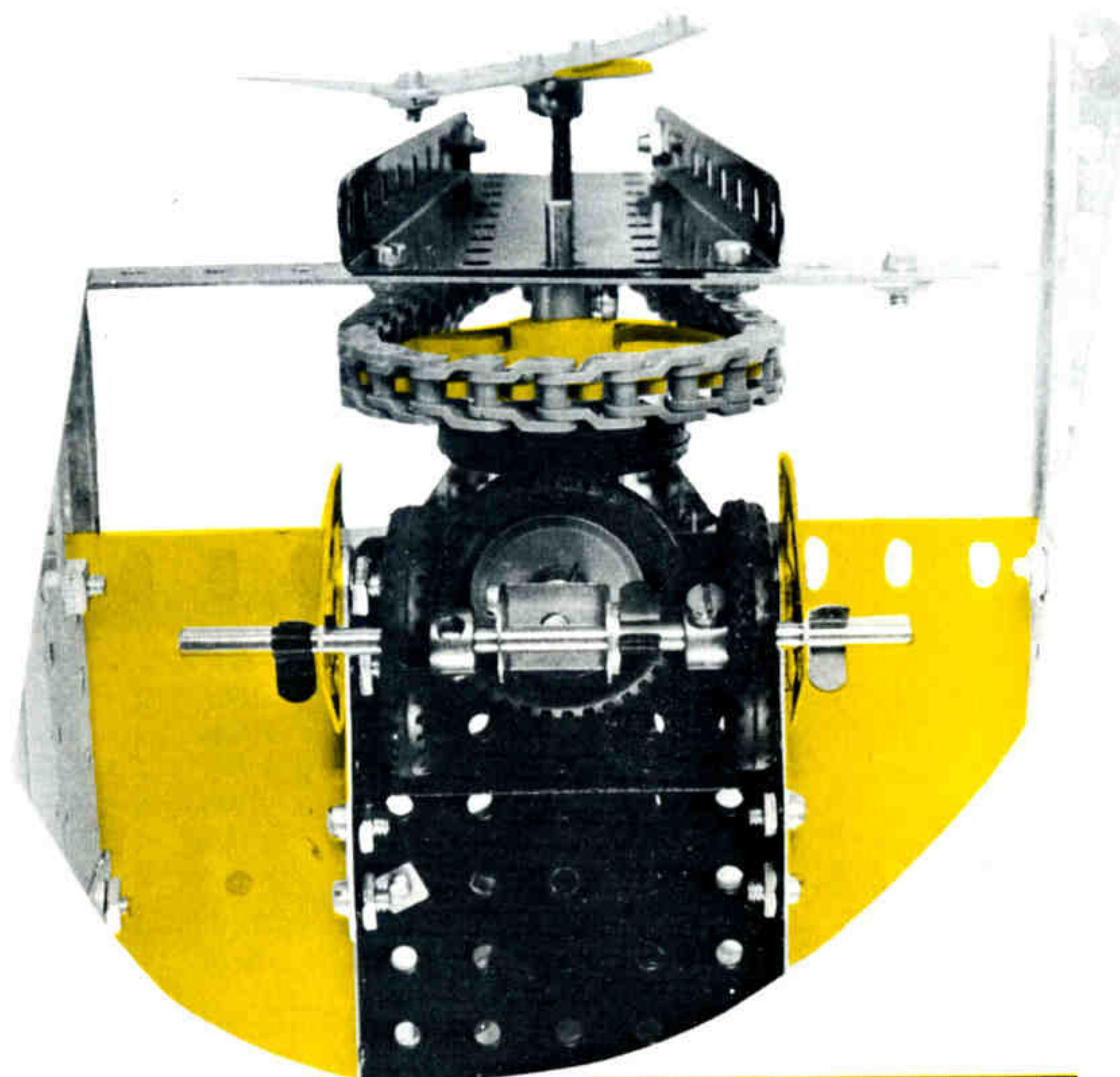
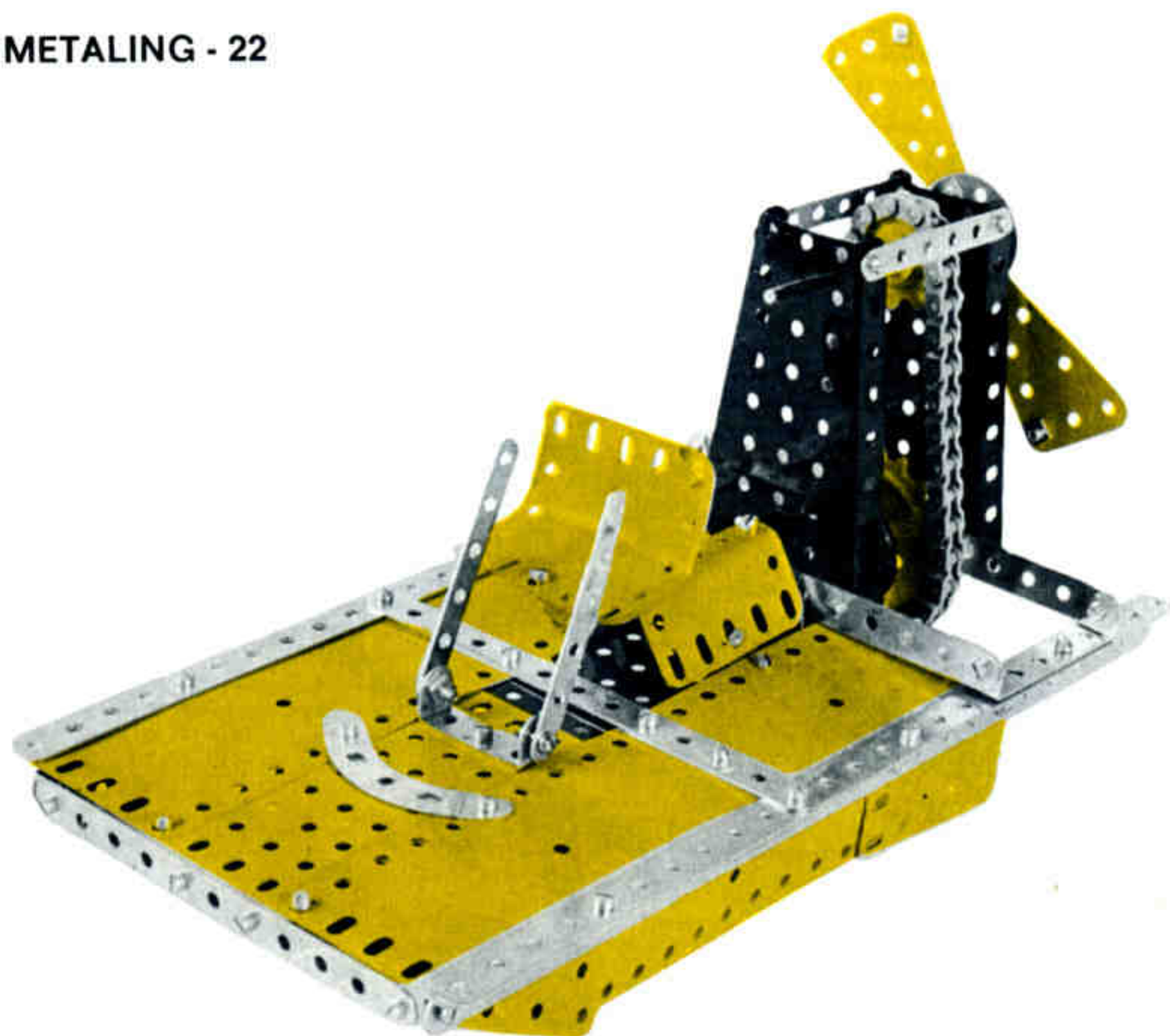

DESLIZADOR 4/238		
4 - 1	68 - 37b	4 - 142c
5 - 2	7 - 38	1 - 155
6 - 5	1 - 48	2 - 188
2 - 11	3 - 48a	2 - 189
1 - 11a	1 - 51	3 - 190
6 - 12	1 - 52	2 - 191
1 - 12c	1 - 53a	2 - 192
2 - 15b	2 - 54	1 - 199
1 - 17	1 - 90a	1 - 200
1 - 18a	1 - 91	4 - 221
4 - 22	1 - 92	4 - 235a
2 - 22a	4 - 111c	1 - 235b
1 - 24	1 - 125	46 - 374
6 - 35	1 - 126	
72 - 37a	2 - 126a	



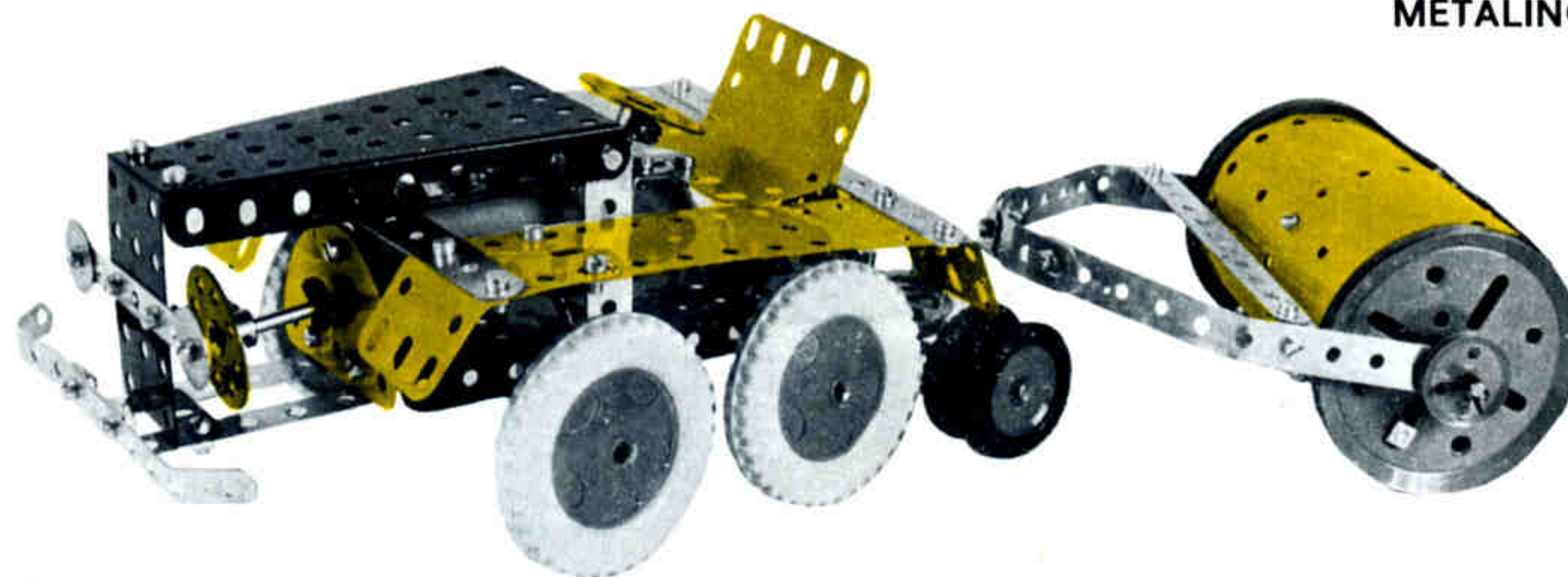

**TRACTOR APLANADOR 4/239**

5 - 2	8 - 35	4 - 142c
2 - 3	2 - 24	1 - 186
2 - 5	69 - 37a	4 - 187
1 - 11a	65 - 37b	2 - 188
6 - 12	4 - 38	2 - 189
2 - 12c	2 - 38d	2 - 191
2 - 16	1 - 48	2 - 192
2 - 17	5 - 48a	1 - 199
1 - 18a	1 - 51	1 - 200
1 - 18b	1 - 52	1 - 215
2 - 19b	1 - 54	3 - 235a
1 - 20a	6 - 111c	2 - 126
4 - 22	1 - 126a	
2 - 22a	2 - 125	

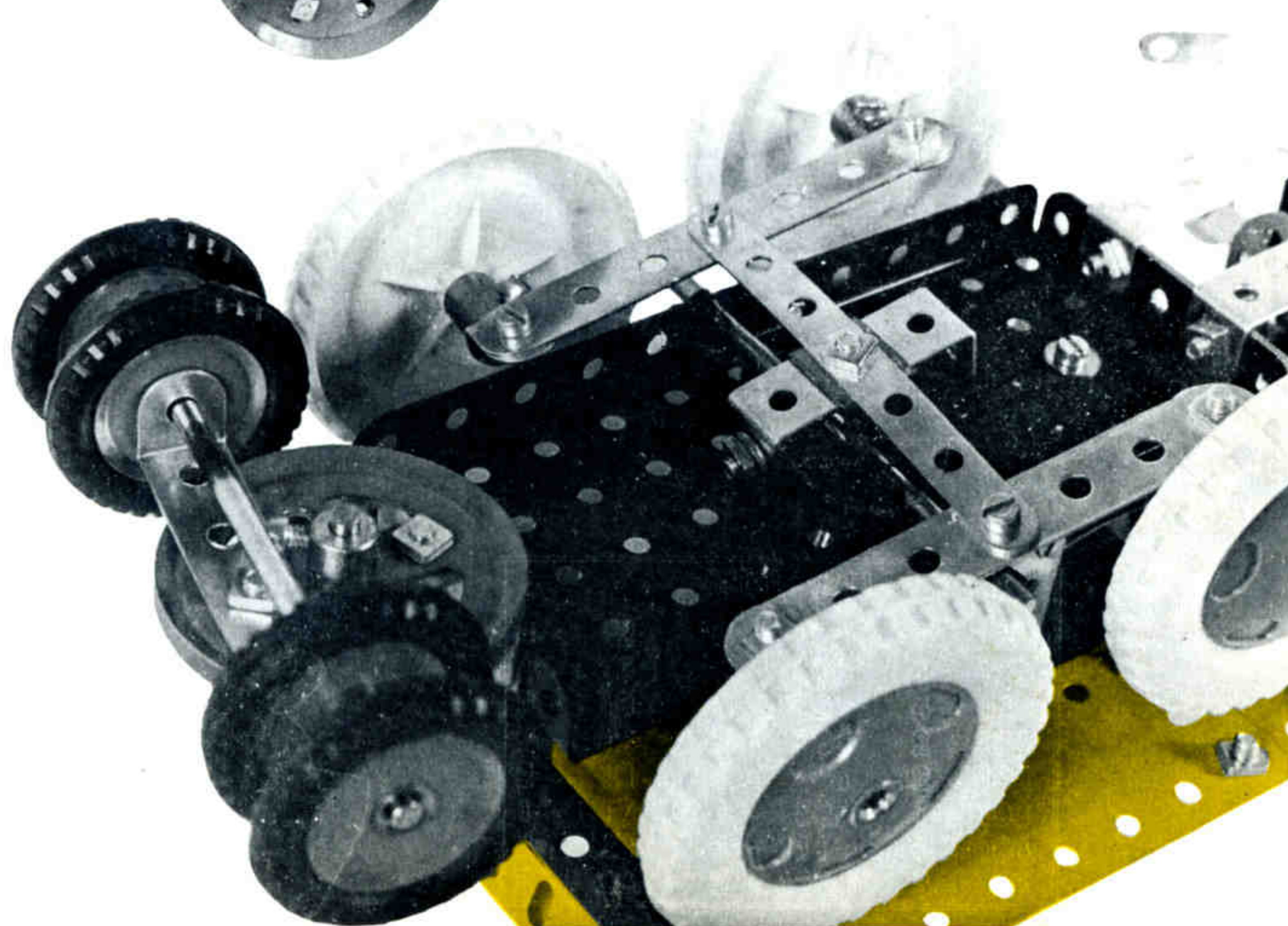

LANCHA A HELICE 4/240

4 - 1	1 - 12c	6 - 35	2 - 53a	1 - 191	1 - 213
8 - 2	1 - 15b	96 - 37a	2 - 54	4 - 192	1 - 213
2 - 3	4 - 16	93 - 37b	4 - 90a	2 - 193	1 - 214
4 - 5	1 - 17	1 - 40	3 - 111c	2 - 193a	2 - 215
4 - 10	2 - 22a	1 - 48	1 - 125	2 - 194a	2 - 221
2 - 11	1 - 23	4 - 48a	1 - 155	1 - 199	1 - 235b
6 - 12	1 - 24	1 - 52	1 - 188	2 - 212a	

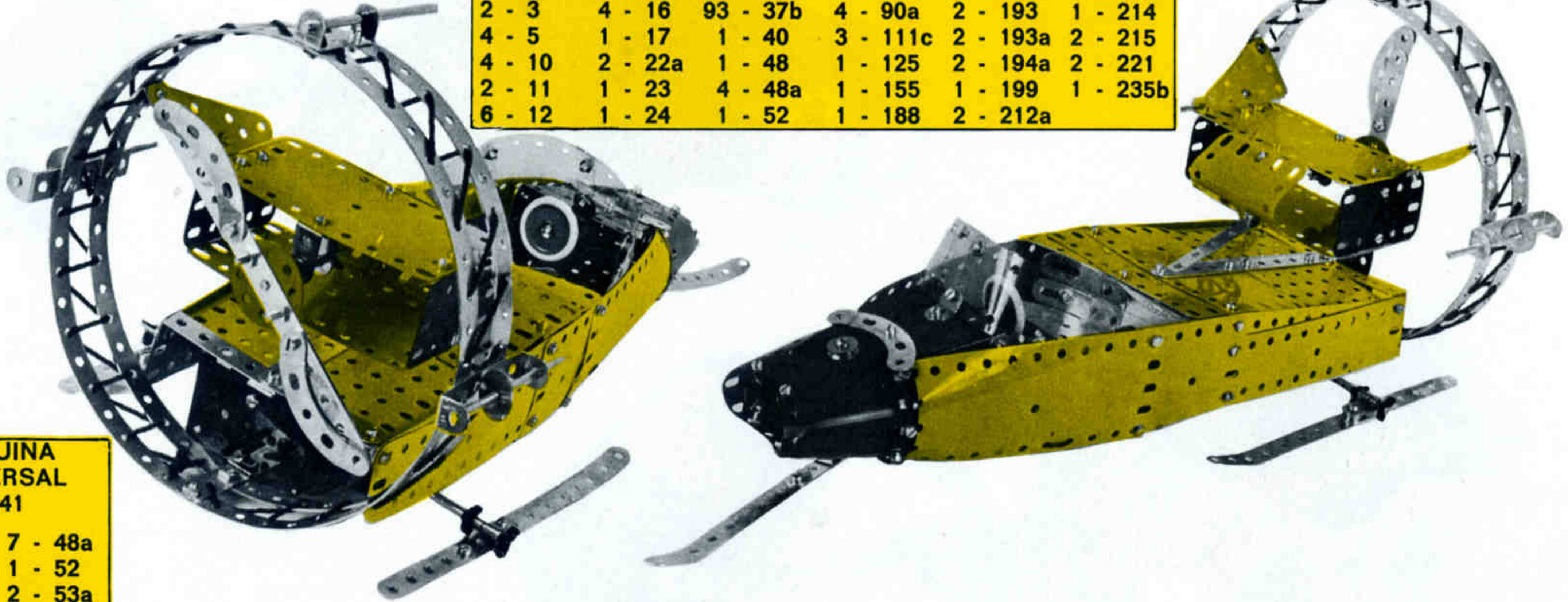

MAQUINA UNIVERSAL 4/241

4 - 1	7 - 48a
8 - 2	1 - 52
8 - 5	2 - 53a
5 - 10	2 - 90a
2 - 11	1 - 91
10 - 12	5 - 111c
4 - 12c	2 - 142c
1 - 15	2 - 188
1 - 15b	2 - 189
1 - 16	2 - 191
1 - 17	2 - 192
1 - 19g	3 - 194
1 - 20a	1 - 199
3 - 22	1 - 200
1 - 23	2 - 212a
2 - 24	2 - 215
5 - 35	2 - 221
85 - 37a	2 - 235a
90 - 37b	4 - 235b
1 - 40	

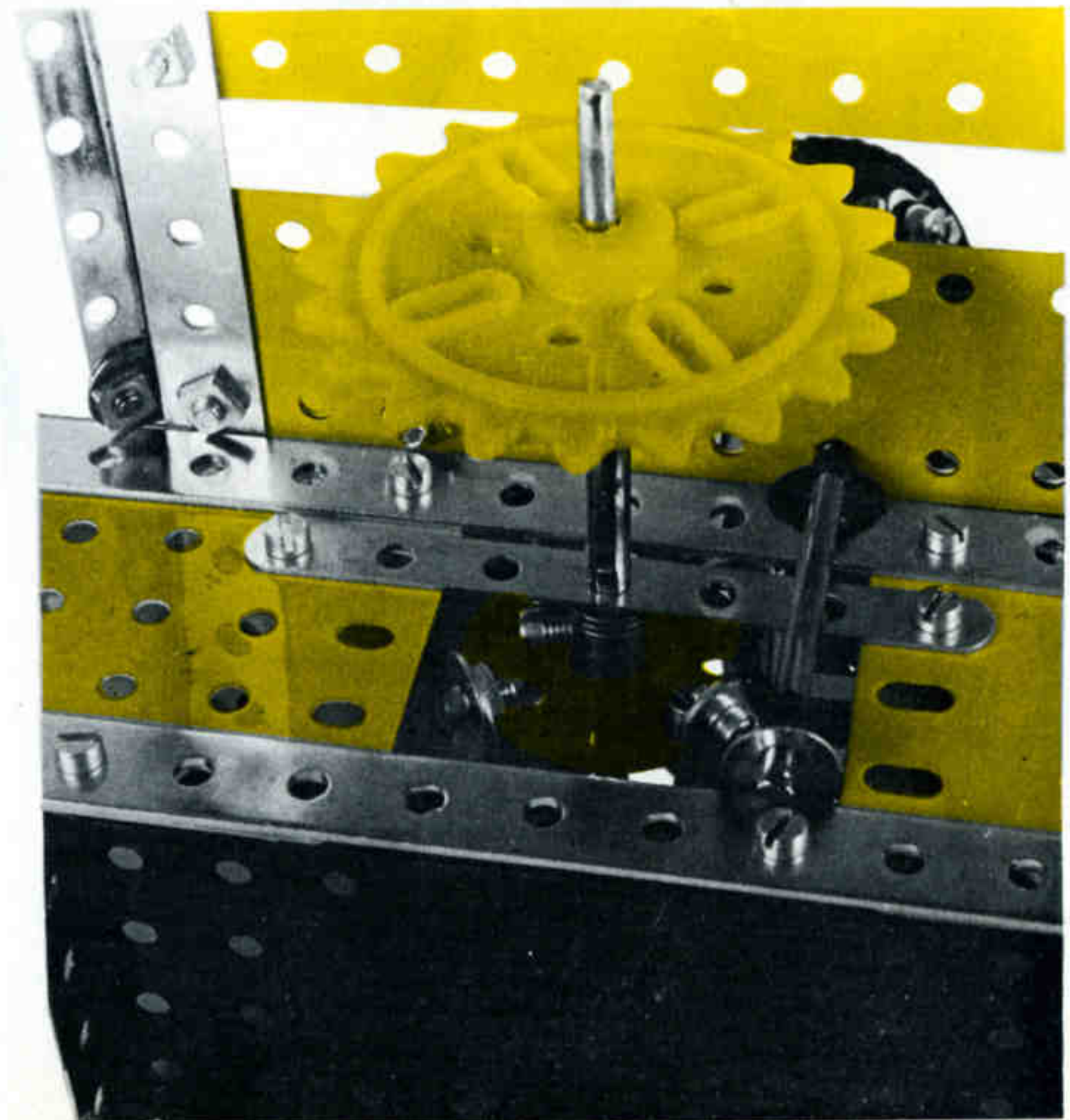
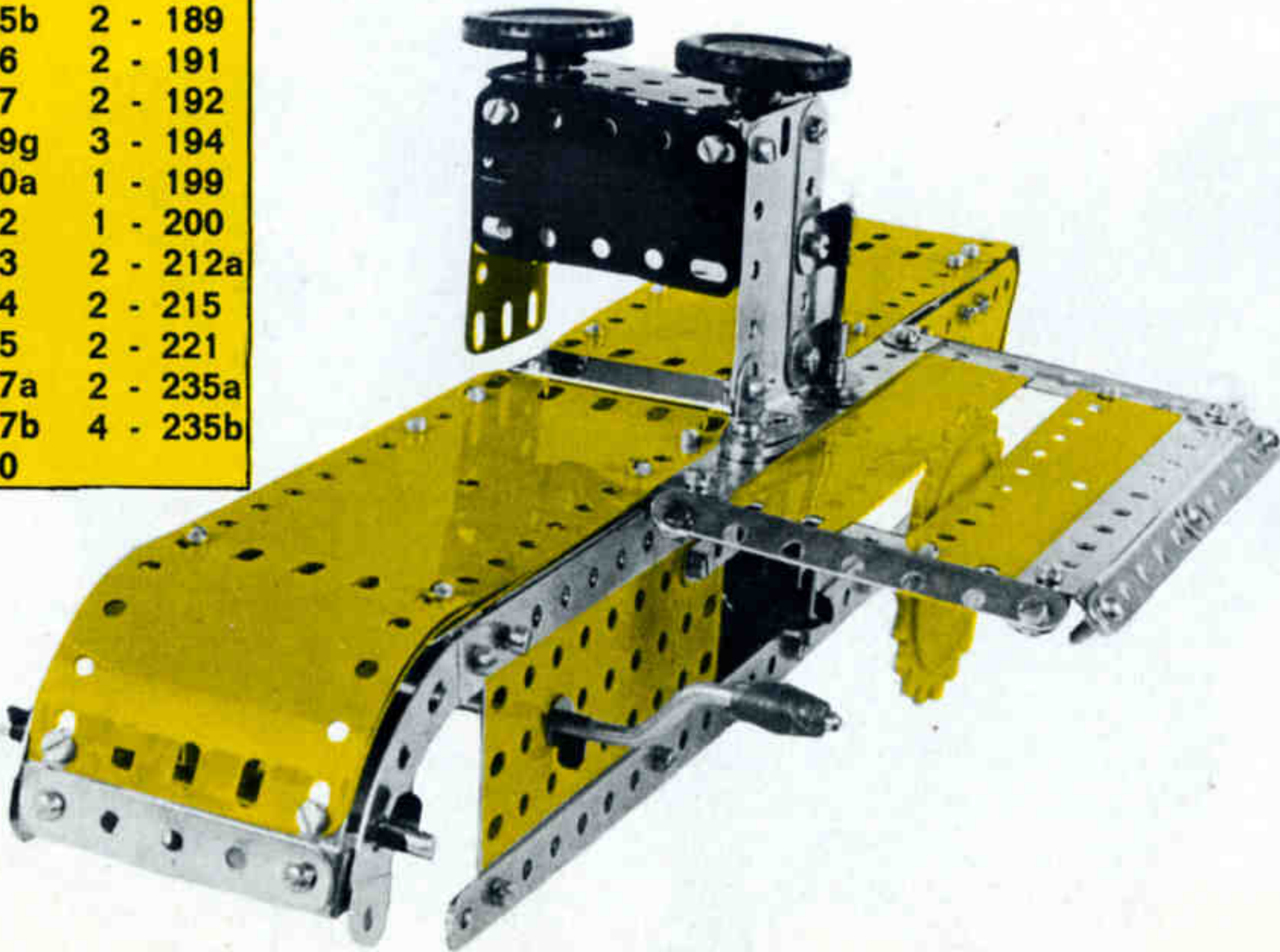



MONTACARGAS 4/242	
4 - 1	1 - 40
8 - 2	6 - 48a
2 - 3	1 - 52
1 - 15b	2 - 53a
1 - 19b	1 - 111c
1 - 19g	2 - 126
2 - 22	2 - 126a
5 - 35	1 - 176
34 - 37a	1 - 186
37 - 37b	2 - 190
4 - 38	2 - 192

CAMION MILITAR 4/243	
3 - 2	2 - 90a
4 - 3	5 - 111c
3 - 5	1 - 125
2 - 11	1 - 142c
10 - 12	1 - 155
4 - 12c	4 - 187
1 - 15b	2 - 188
2 - 16	2 - 189
3 - 22	3 - 190
2 - 24	2 - 191
6 - 35	1 - 192
83 - 37a	1 - 193a
72 - 37b	2 - 194
10 - 38	1 - 200
2 - 48a	2 - 214
1 - 51	2 - 215
1 - 52	4 - 221
2 - 53a	

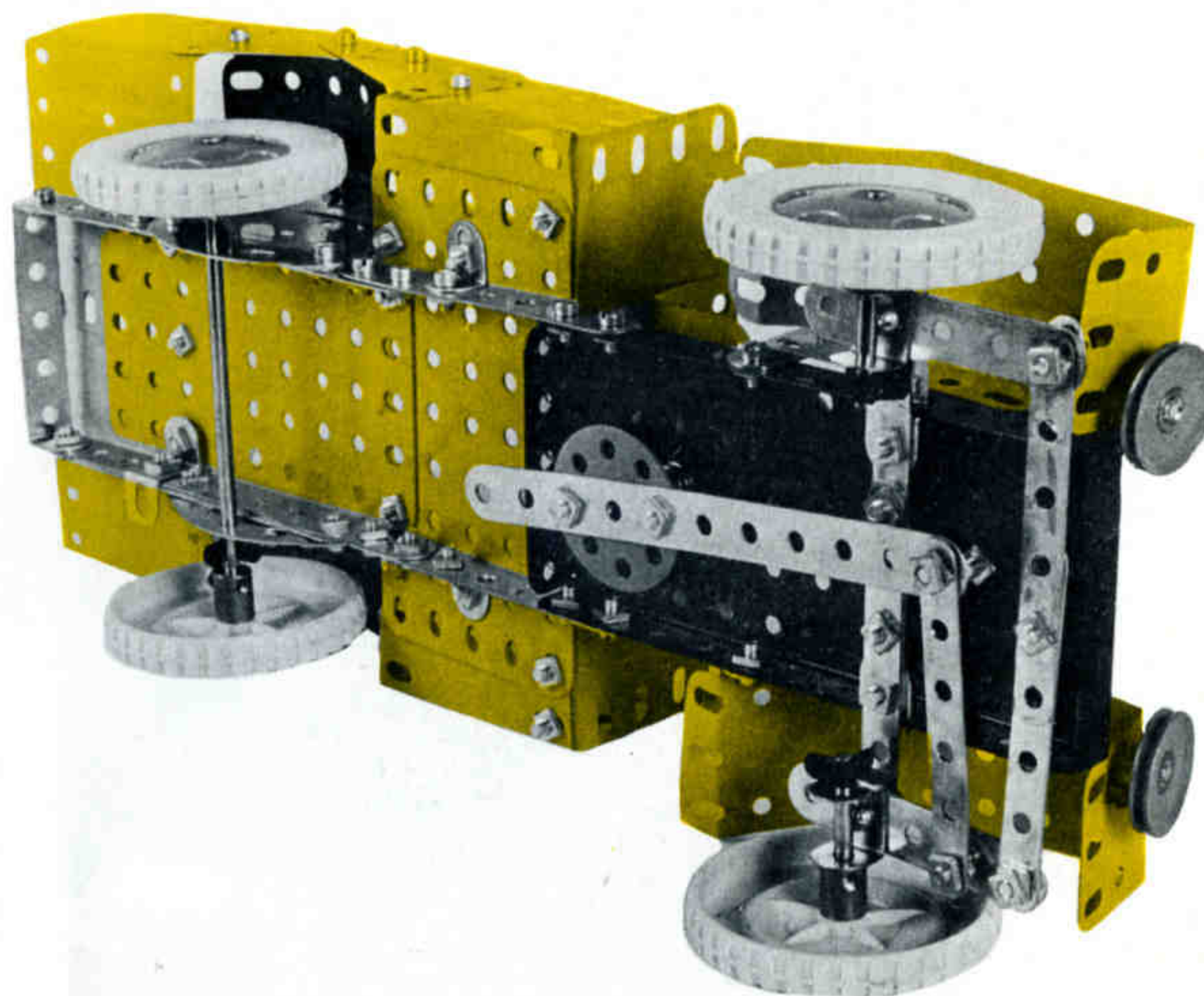
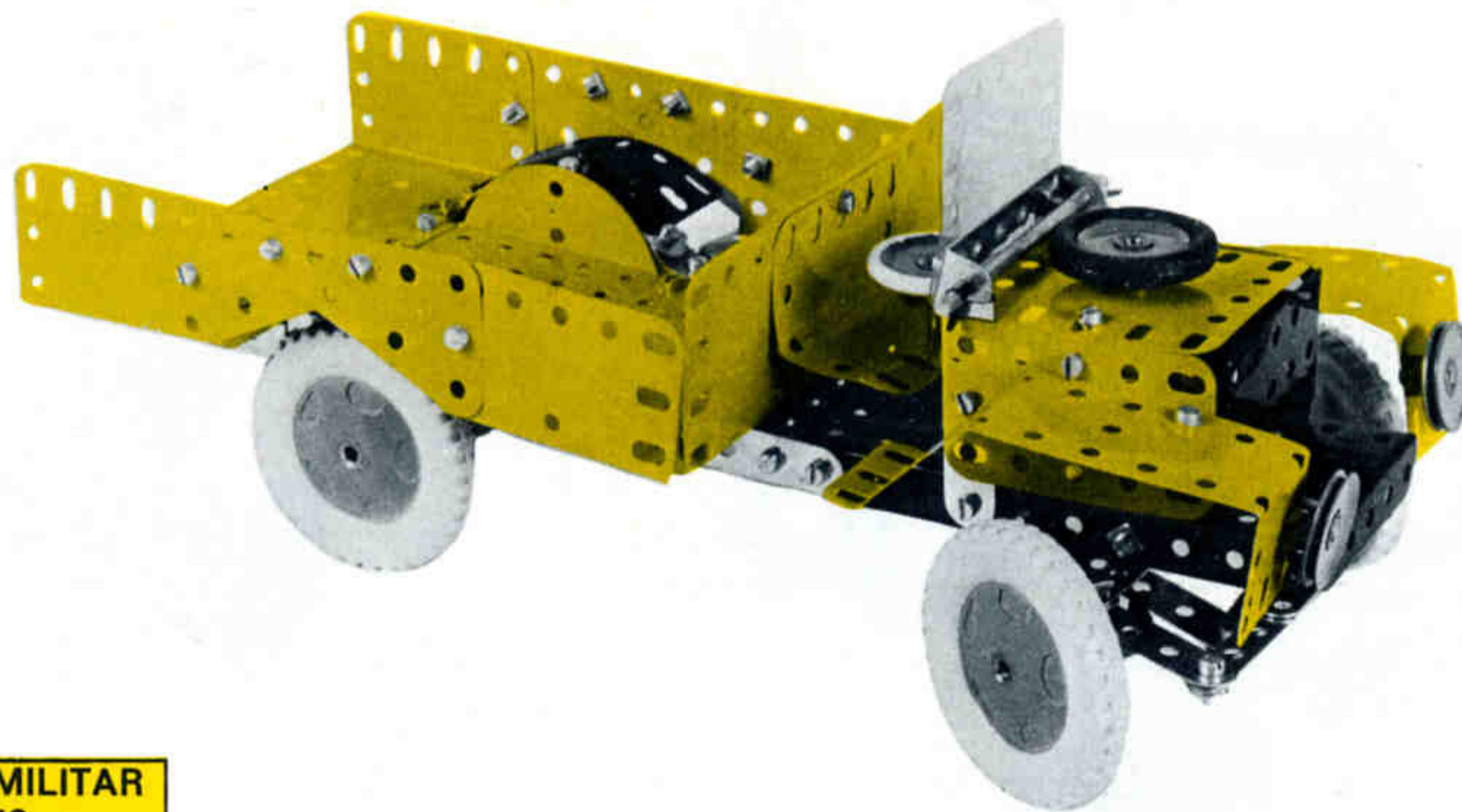

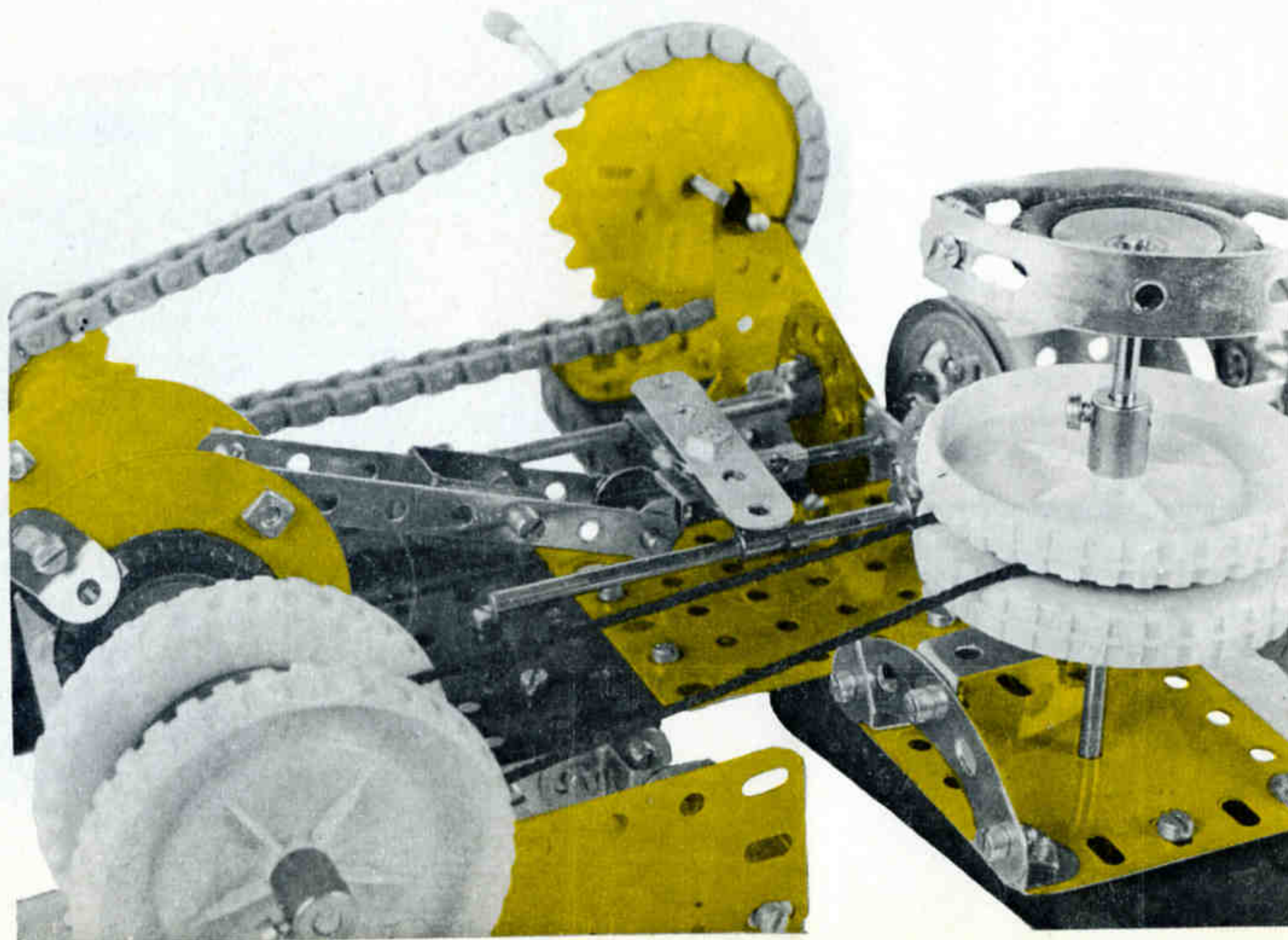
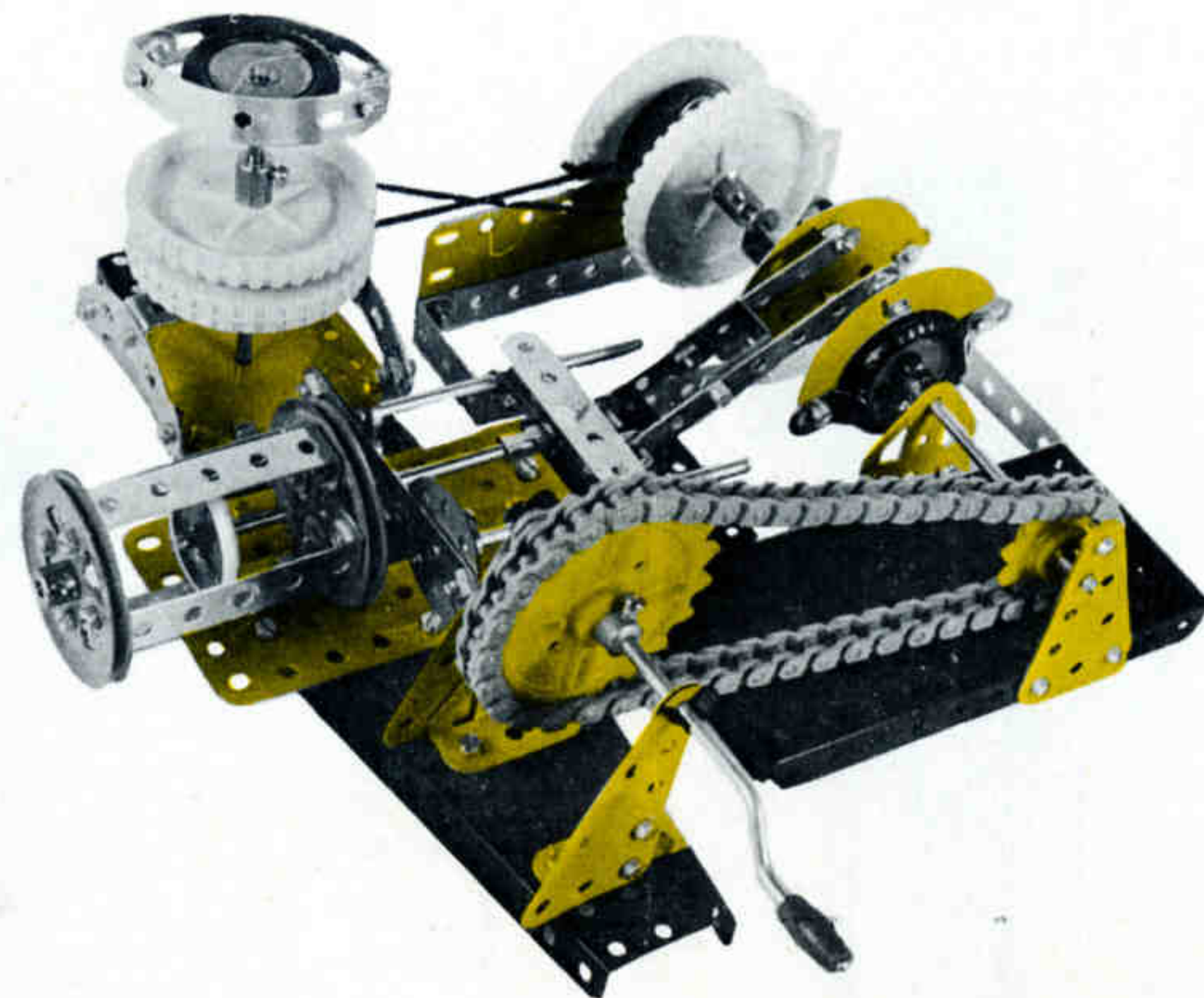
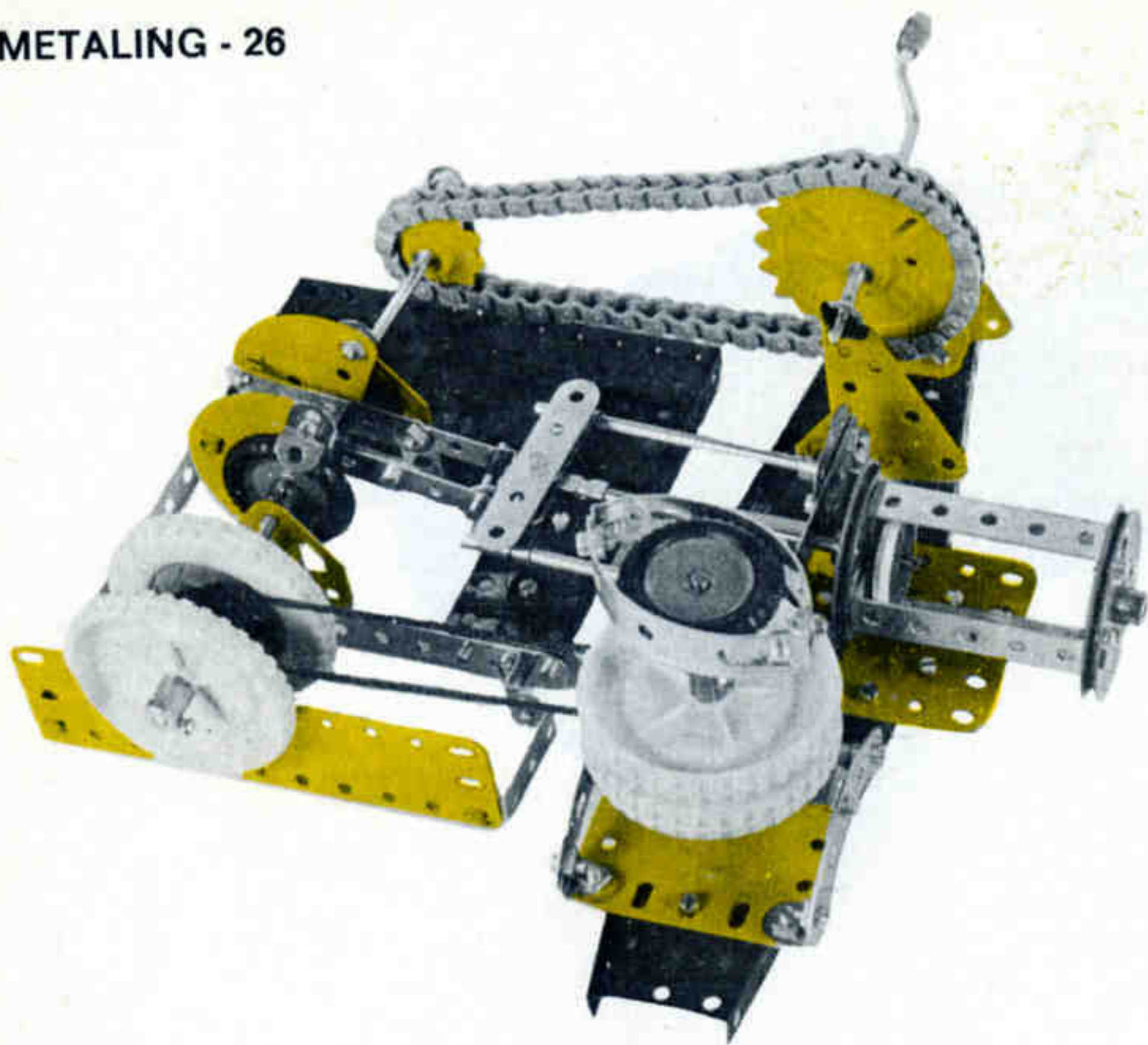

**MAQUINA  
DE VAPOR  
4/244**

4 - 2	6 - 48a
1 - 3	1 - 51
6 - 5	1 - 53a
4 - 10	2 - 54
3 - 11	2 - 90a
1 - 11a	1 - 91
7 - 12	1 - 92
4 - 12c	2 - 111a
2 - 15a	2 - 125
2 - 16	2 - 126
1 - 18b	2 - 126a
1 - 19g	3 - 142c
2 - 20a	1 - 155
4 - 22	4 - 187
2 - 22a	1 - 189
2 - 24	2 - 190
3 - 35	1 - 212
90 - 37a	2 - 212a
100 - 37b	2 - 214
7 - 38	2 - 215
2 - 38d	3 - 221
1 - 40	2 - 235b
1 - 48	45 - 374

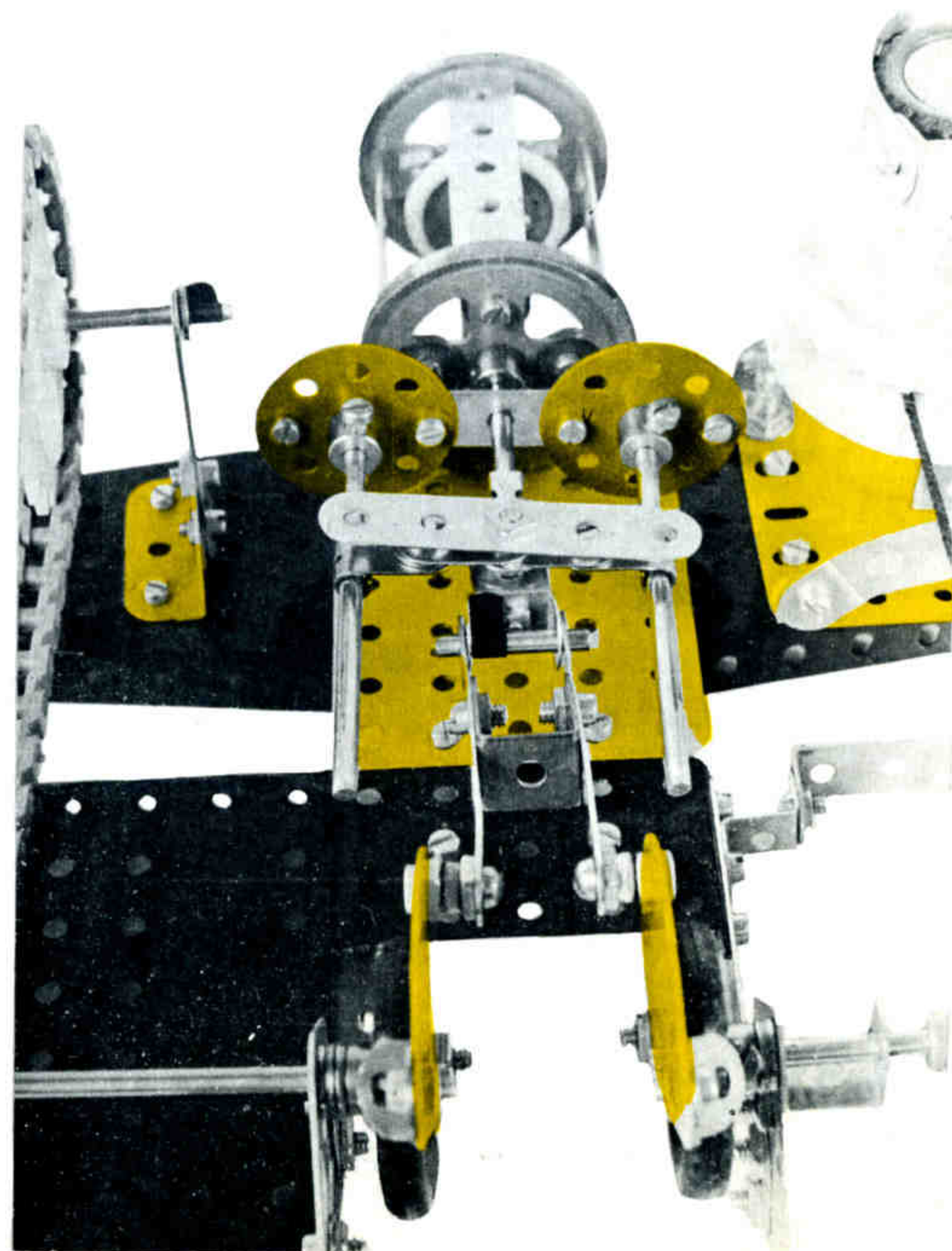
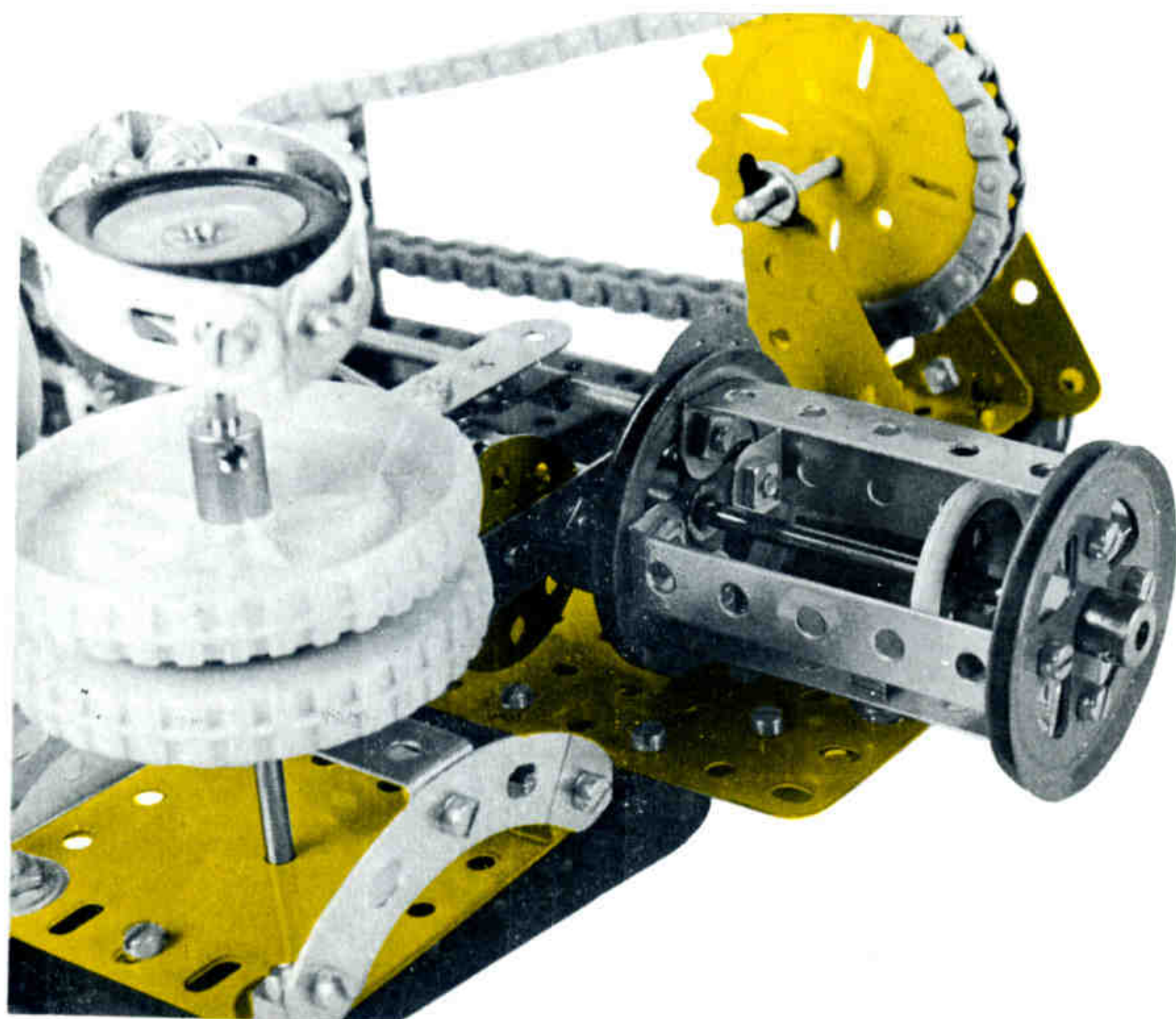

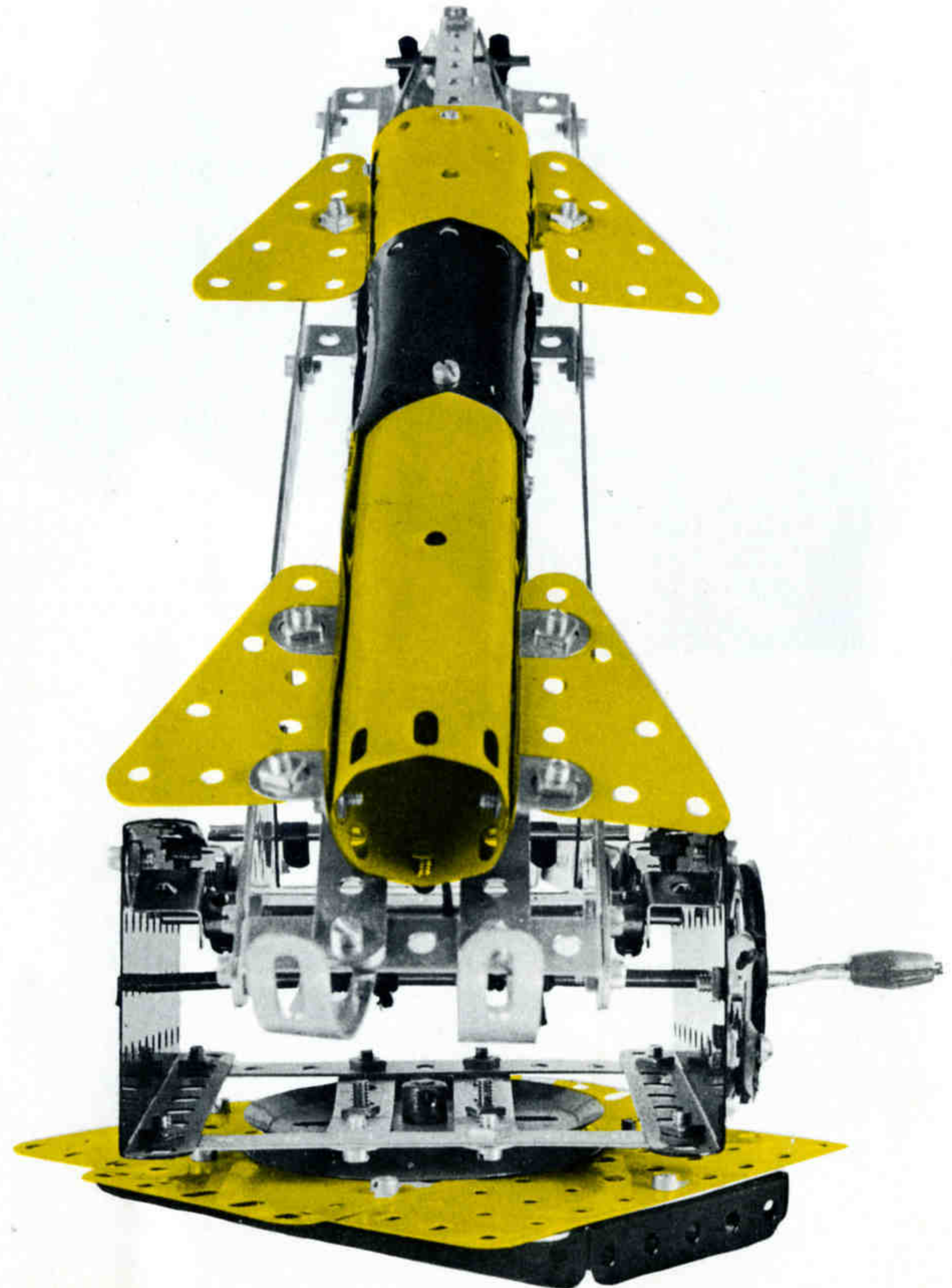

**LANZA COHETES 4/245**

4 - 1	1 - 18b	64 - 37b	1 - 186
2 - 3	1 - 19b	1 - 40	2 - 190
1 - 5	1 - 19g	1 - 48	1 - 192
7 - 12	1 - 20a	3 - 48a	1 - 213
1 - 12c	2 - 22	1 - 52	2 - 214
1 - 15b	1 - 23	2 - 53a	2 - 215
1 - 16	1 - 24	2 - 54	4 - 221
1 - 17	4 - 35	4 - 111c	3 - 235a
1 - 18a	64 - 37a	2 - 125	4 - 235b

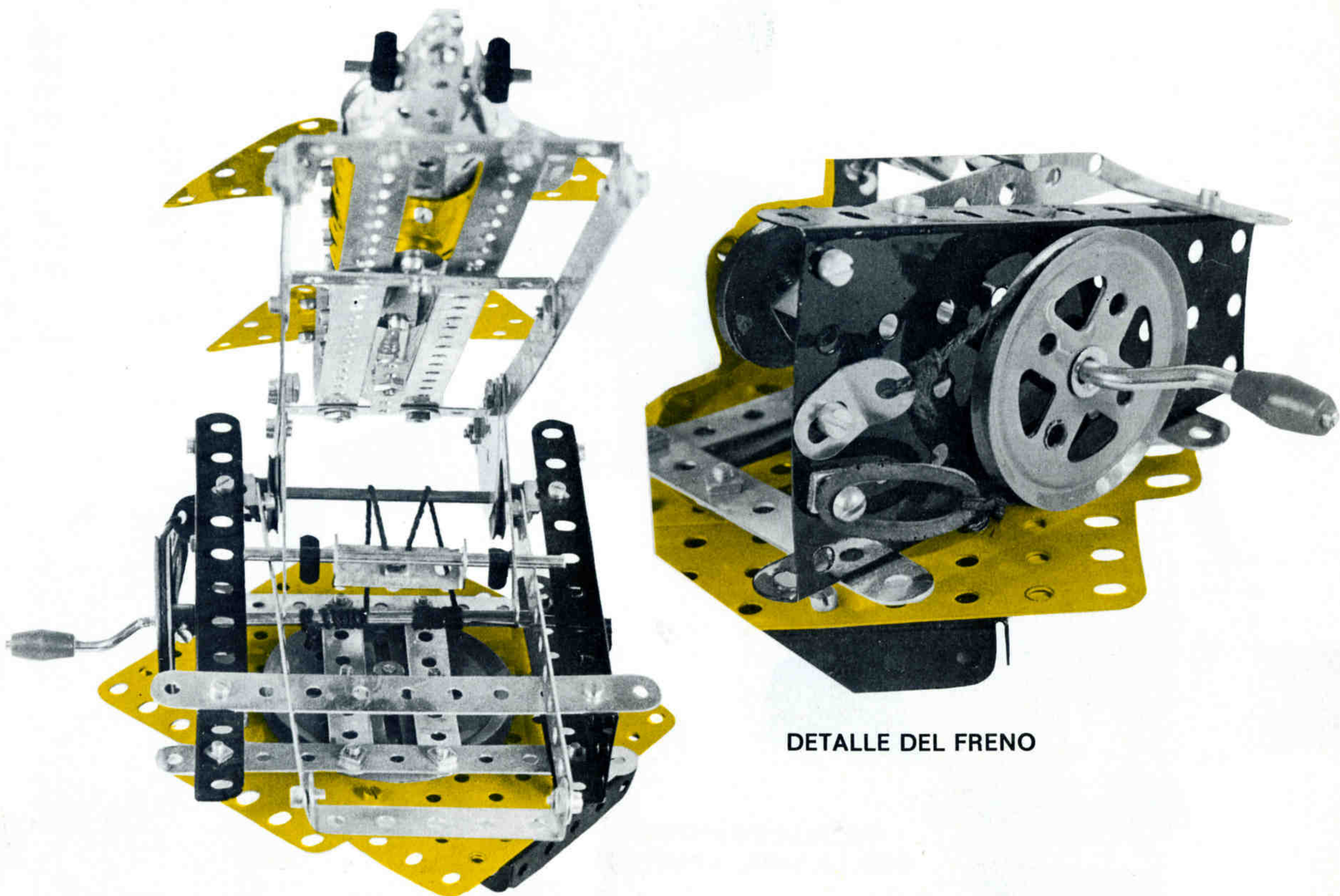

DETALLE DEL FRENO

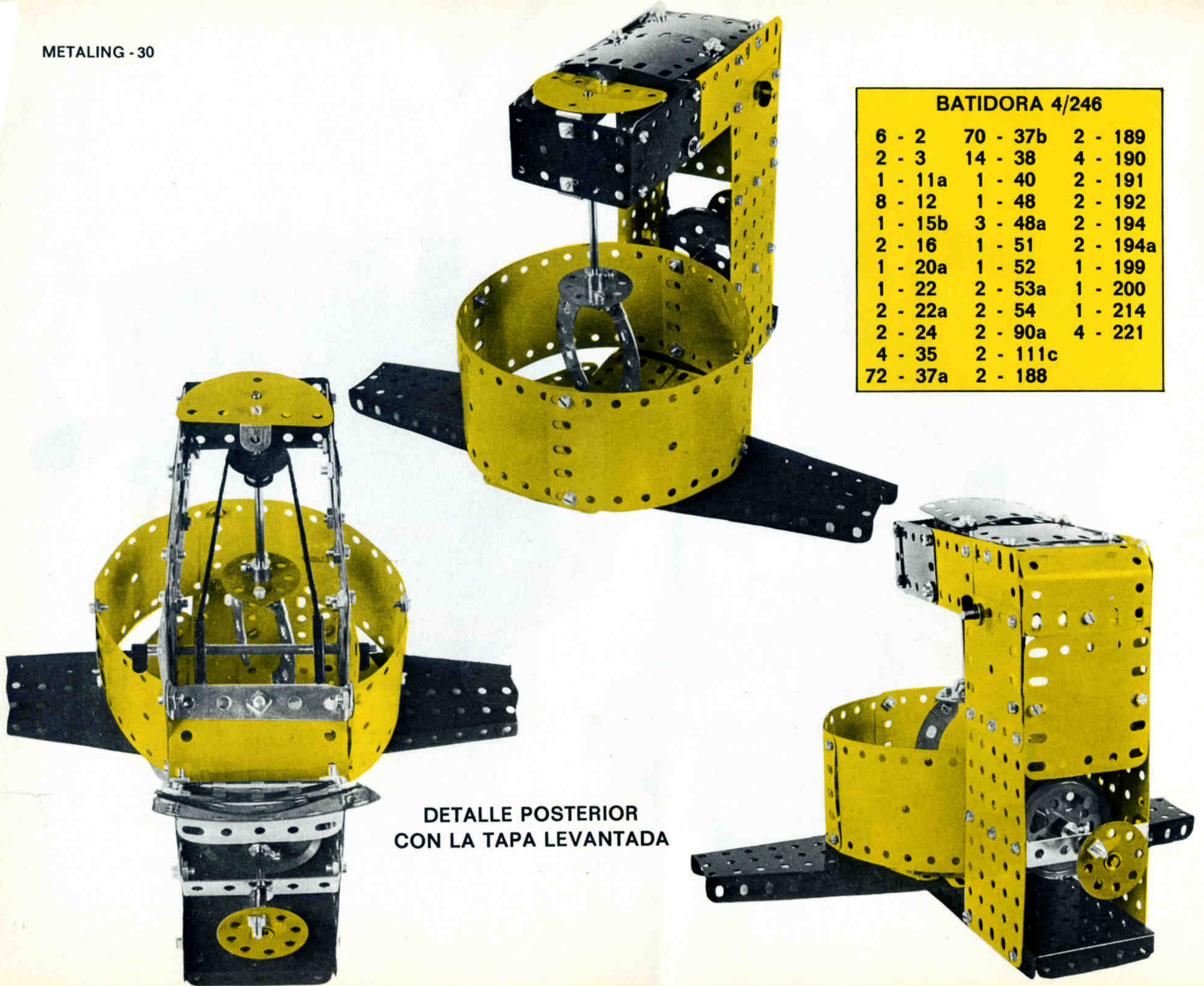

**BATIDORA 4/246**

6 - 2	70 - 37b	2 - 189
2 - 3	14 - 38	4 - 190
1 - 11a	1 - 40	2 - 191
8 - 12	1 - 48	2 - 192
1 - 15b	3 - 48a	2 - 194
2 - 16	1 - 51	2 - 194a
1 - 20a	1 - 52	1 - 199
1 - 22	2 - 53a	1 - 200
2 - 22a	2 - 54	1 - 214
2 - 24	2 - 90a	4 - 221
4 - 35	2 - 111c	
72 - 37a	2 - 188	

**DETALLE POSTERIOR  
CON LA TAPA LEVANTADA**





**MOLINO 4/247**

2 - 1	1 - 52
8 - 2	2 - 53a
8 - 5	1 - 90a
6 - 12	1 - 111c
1 - 15b	1 - 126
1 - 16	1 - 126a
1 - 20a	2 - 188
1 - 22	2 - 189
2 - 22a	4 - 190
1 - 23	2 - 191
1 - 24	2 - 192
73 - 37a	1 - 200
72 - 37b	1 - 91
5 - 38	1 - 92
1 - 48	46 - 374
6 - 48a	

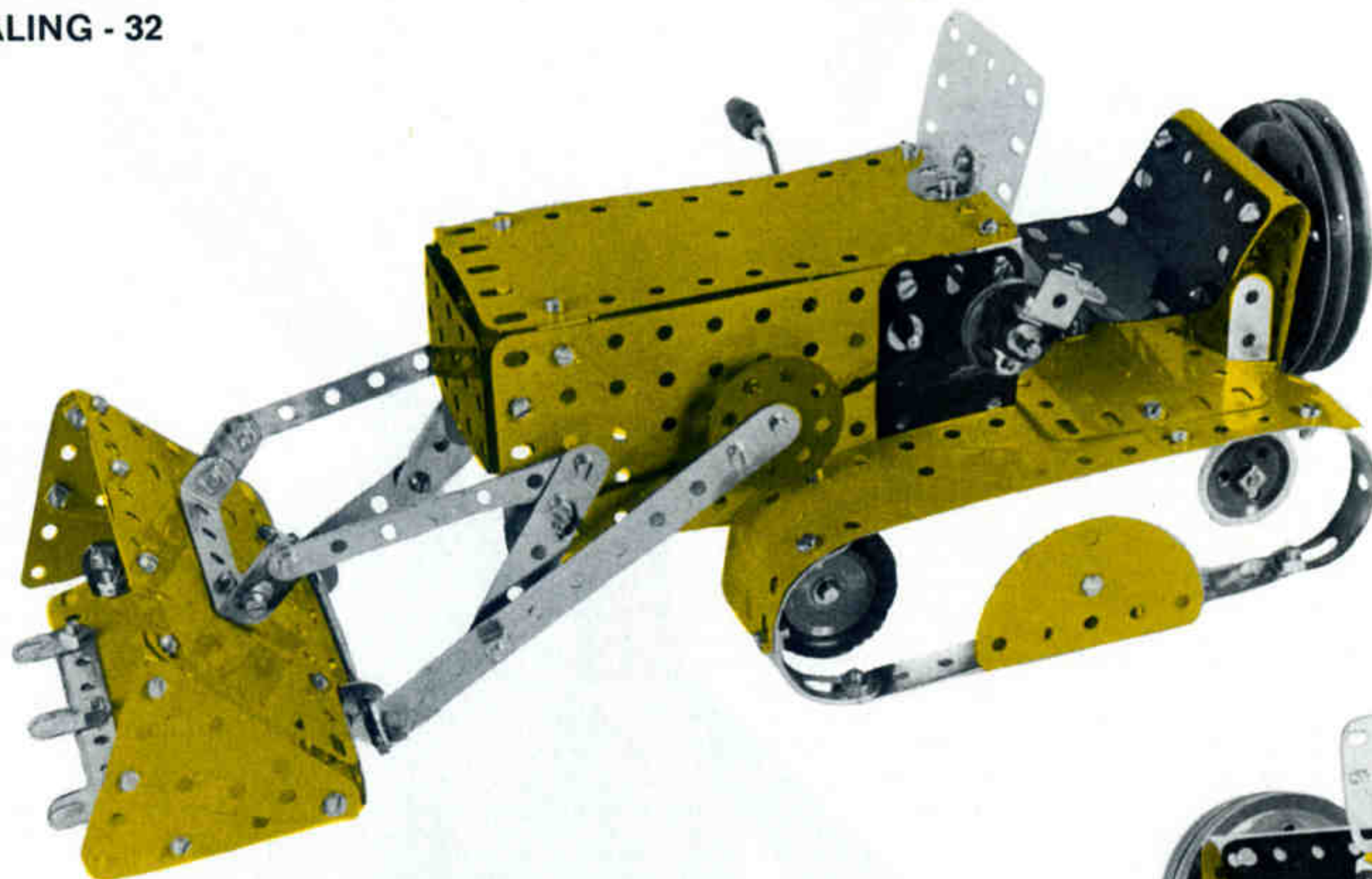

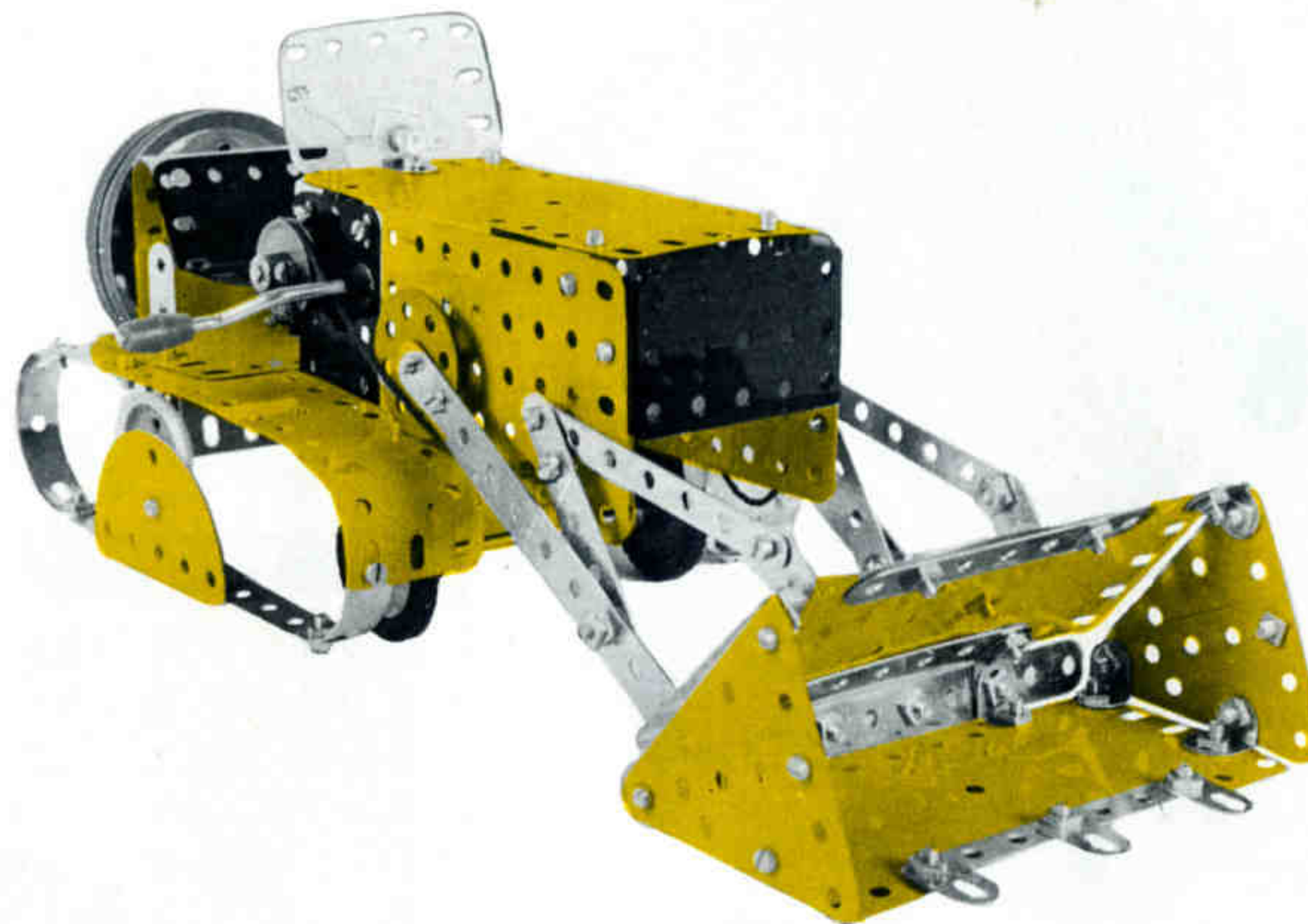
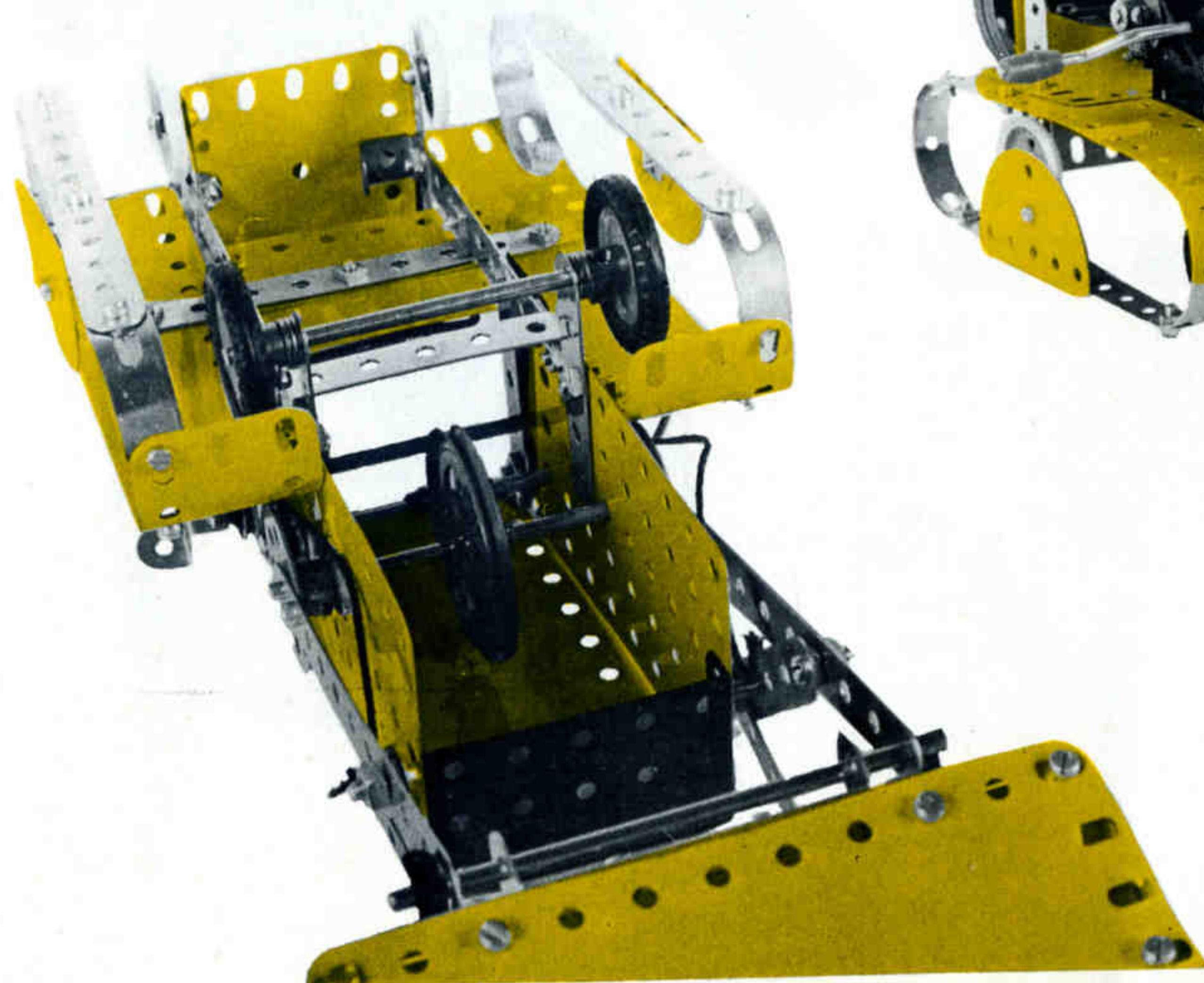

BULLDOZER 4/248			
8 - 2	4 - 22	2 - 126	1 - 51
8 - 5	2 - 22a	2 - 142c	1 - 199
5 - 10	2 - 24	2 - 155	1 - 212
2 - 11	5 - 35	1 - 176	1 - 213
10 - 12	100 - 37a	2 - 188	2 - 214
3 - 12c	91 - 37b	2 - 189	4 - 215
1 - 15a	1 - 23	2 - 190	4 - 221
2 - 16	5 - 38	2 - 191	2 - 3
1 - 18b	6 - 48a	2 - 192	3 - 235b
1 - 198	2 - 53a	1 - 193	
2 - 19b	3 - 111c	2 - 194	
1 - 20a	1 - 125	1 - 194a	



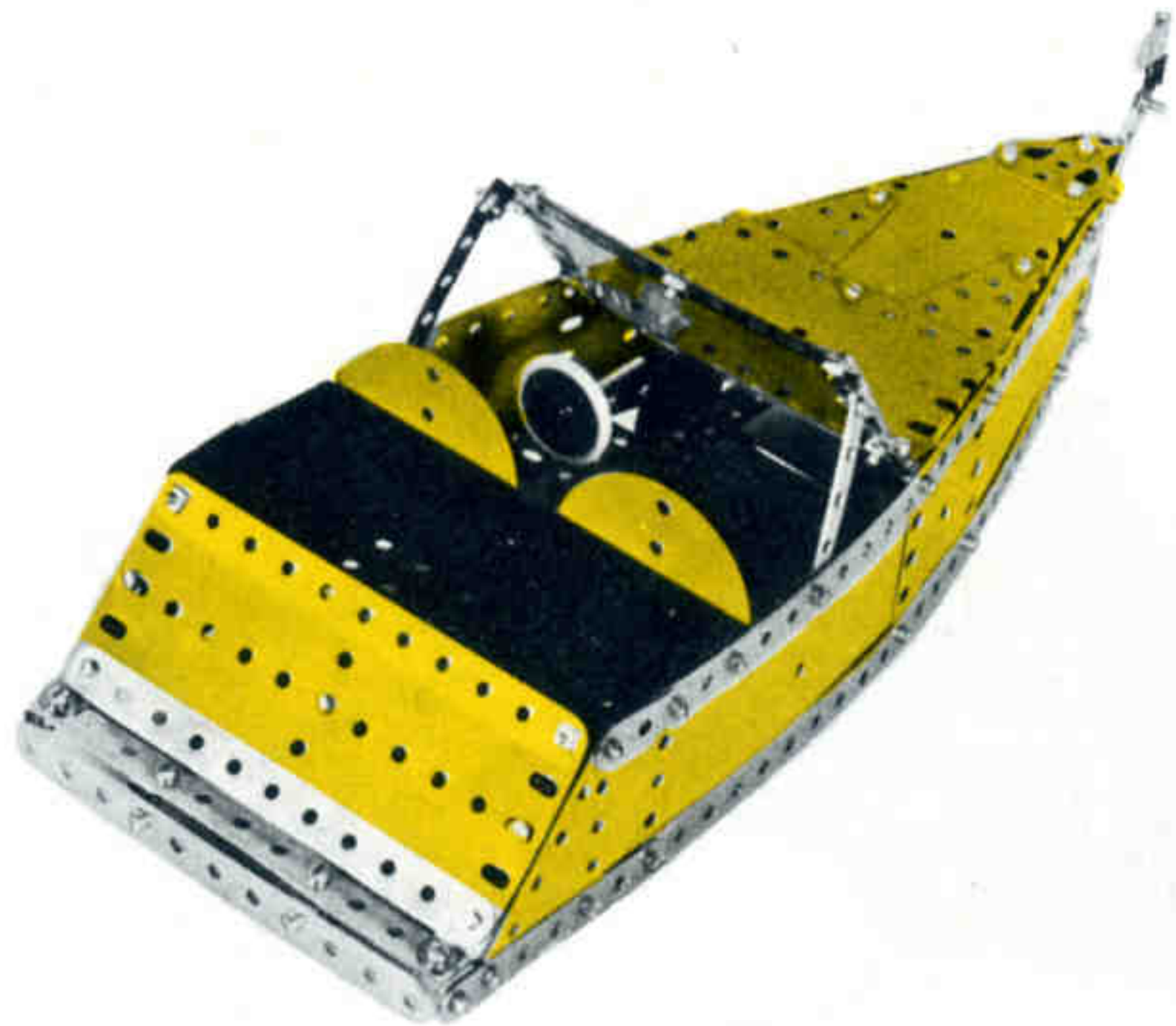

**CANOA DE RECREO 5/249**

4 - 1	2 - 35	2 - 190
5 - 2	79 - 37a	2 - 191
2 - 4	78 - 37b	4 - 192
4 - 5	1 - 48a	1 - 193c
2 - 6a	1 - 52	1 - 199
2 - 8	1 - 53a	1 - 212
1 - 10	1 - 111c	1 - 212a
1 - 11	2 - 126	2 - 214
10 - 12	1 - 126a	2 - 221
4 - 12c	4 - 142c	4 - 235
3 - 16	1 - 155	2 - 235b
1 - 18a	2 - 188	
5 - 22	4 - 189	

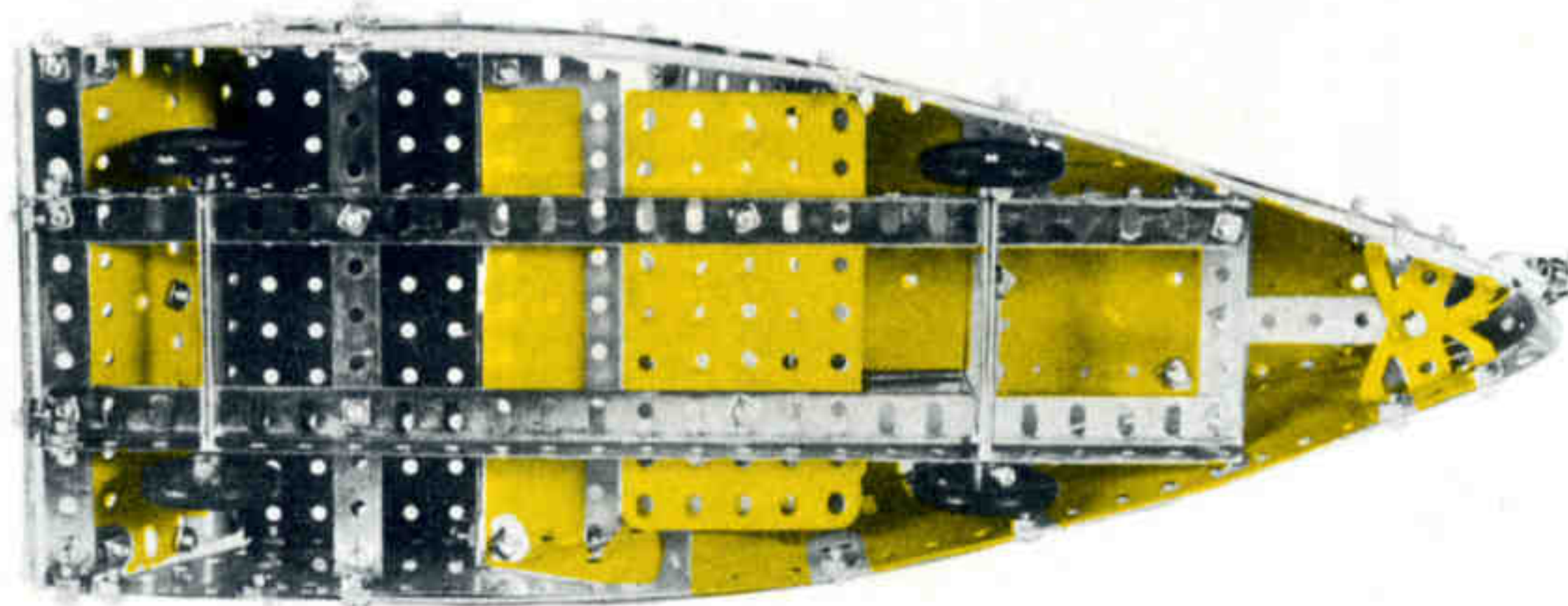

**PRENSA AUTOMATICA 5/250**

4 - 2	30 - 37b
5 - 5	8 - 37c
2 - 15	4 - 38
1 - 16	6 - 48a
1 - 17	1 - 52
1 - 19b	4 - 90a
5 - 22	1 - 115
2 - 24	2 - 126
4 - 35	2 - 155
32 - 37a	1 - 186b

SCOOTER 5/251

4 - 2	2 - 12a	11 - 38	2 - 125	1 - 193a
2 - 4	1 - 12c	1 - 48	2 - 126	1 - 215
7 - 5	2 - 17	7 - 48a	2 - 126a	2 - 221
2 - 6a	1 - 22a	3 - 90a	3 - 187	2 - 214
1 - 11	2 - 35	1 - 51	3 - 188	
1 - 11a	67 - 37a	2 - 111a	3 - 190	
2 - 12	59 - 37b	4 - 111c	2 - 192	



HELICOPTERO 5/252

3 - 1	11 - 12	2 - 22a	1 - 52	3 - 189	2 - 222
13 - 2	4 - 12c	1 - 24	2 - 53a	2 - 190	2 - 235
2 - 4	1 - 15b	1 - 35	2 - 90a	2 - 191	2 - 235a
6 - 5	1 - 18a	105 - 37a	2 - 111a	4 - 192	4 - 235b
2 - 6a	1 - 18b	99 - 37b	4 - 111c	2 - 193a	
4 - 8	1 - 20a	6 - 38	3 - 142c	1 - 193e	
1 - 11a	2 - 22	4 - 48a	4 - 188	4 - 221	

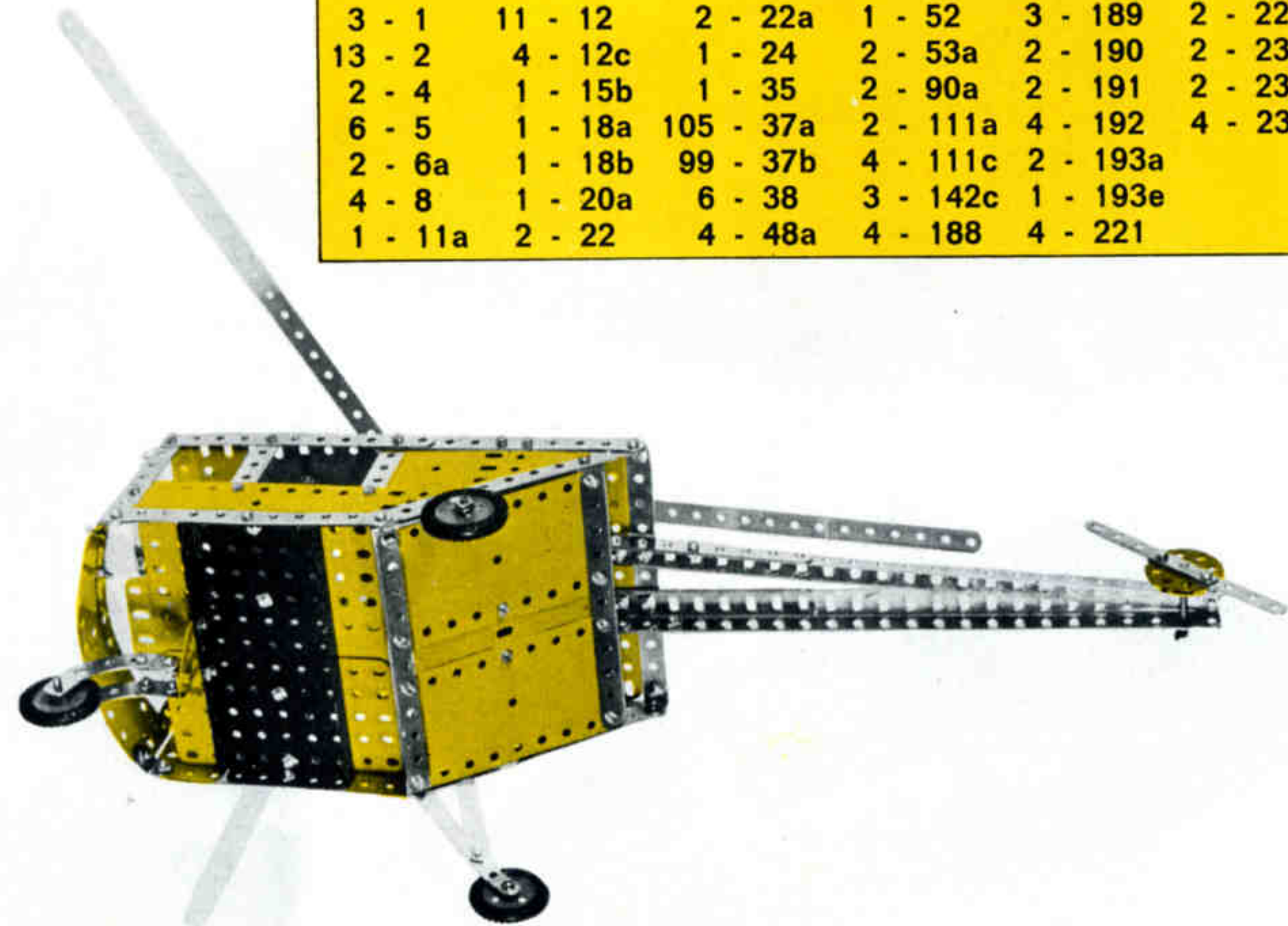

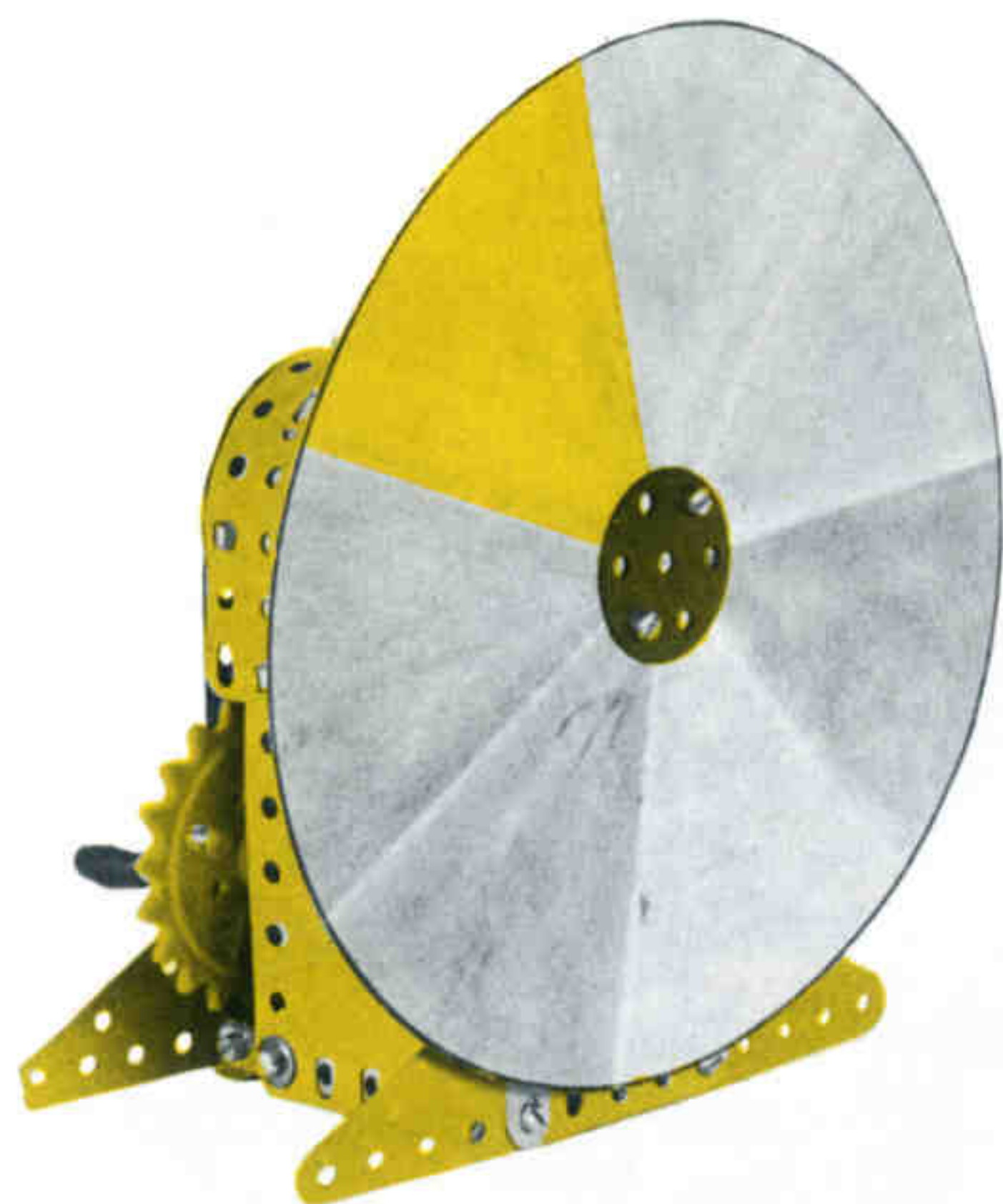

ESPECTRO SOLAR 5/253		
2 - 12	3 - 35	1 - 92
2 - 16	34 - 37a	2 - 189
1 - 19g	34 - 37b	2 - 192
1 - 24	12 - 38	1 - 200
1 - 24c	4 - 48a	2 - 214
1 - 26	2 - 53a	4 - 221
1 - 27a	1 - 91	4 - 235a



CIRCULO DE CARTULINA DE 20 cm. Ø DIVI-  
DIDO EN SIETE PARTES, QUE PINTARAS  
CON LOS COLORES DEL ARCO IRIS.

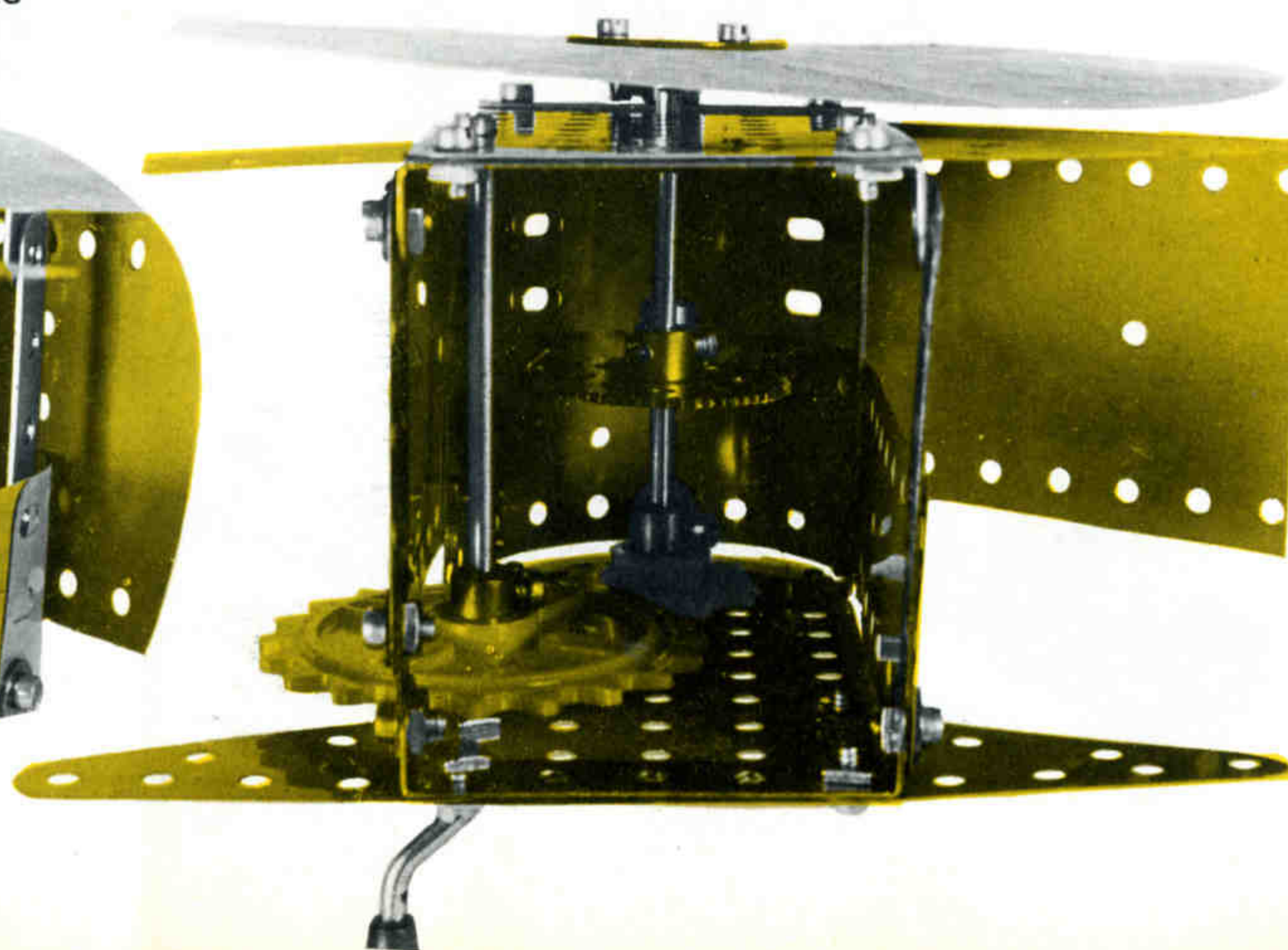
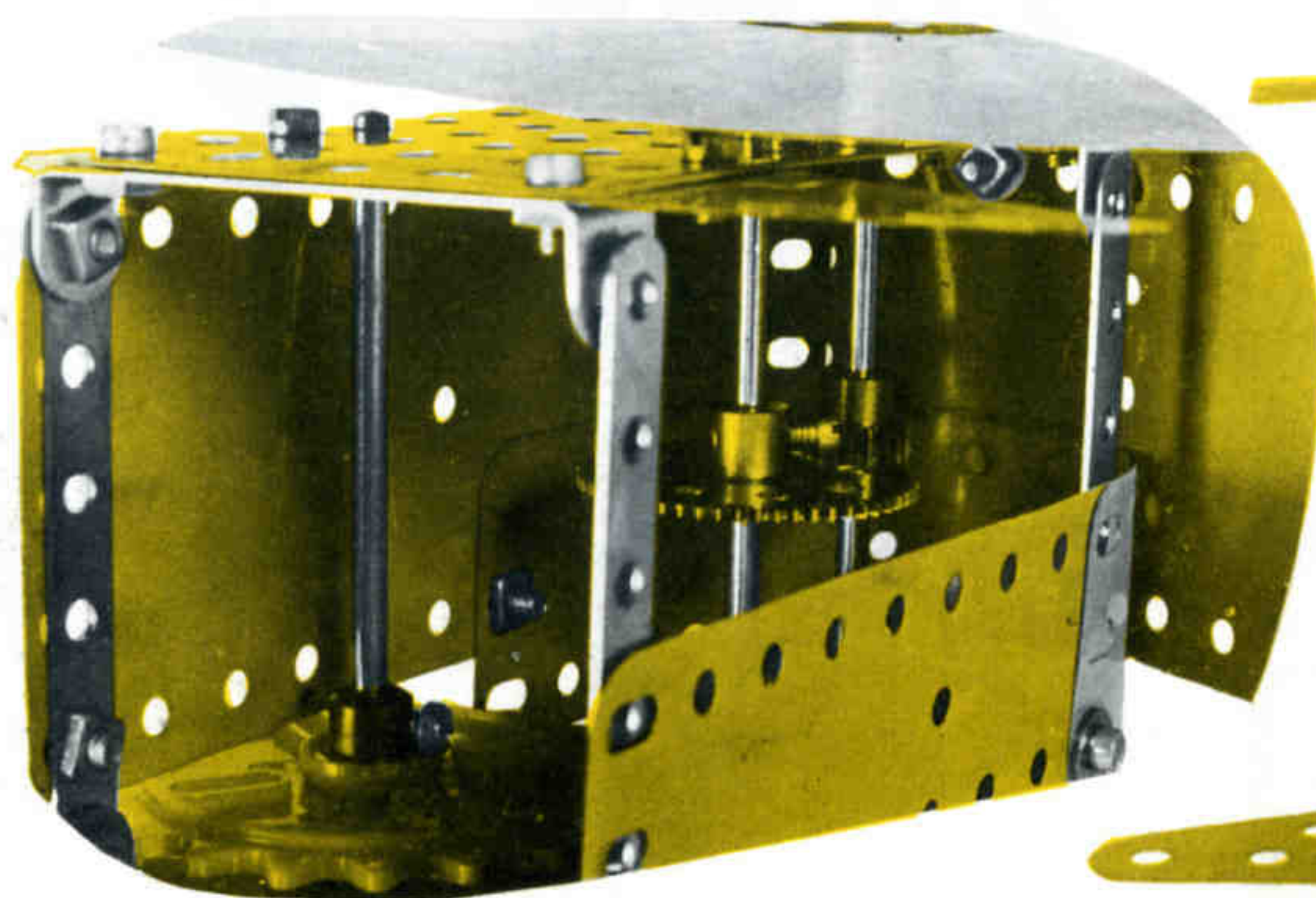

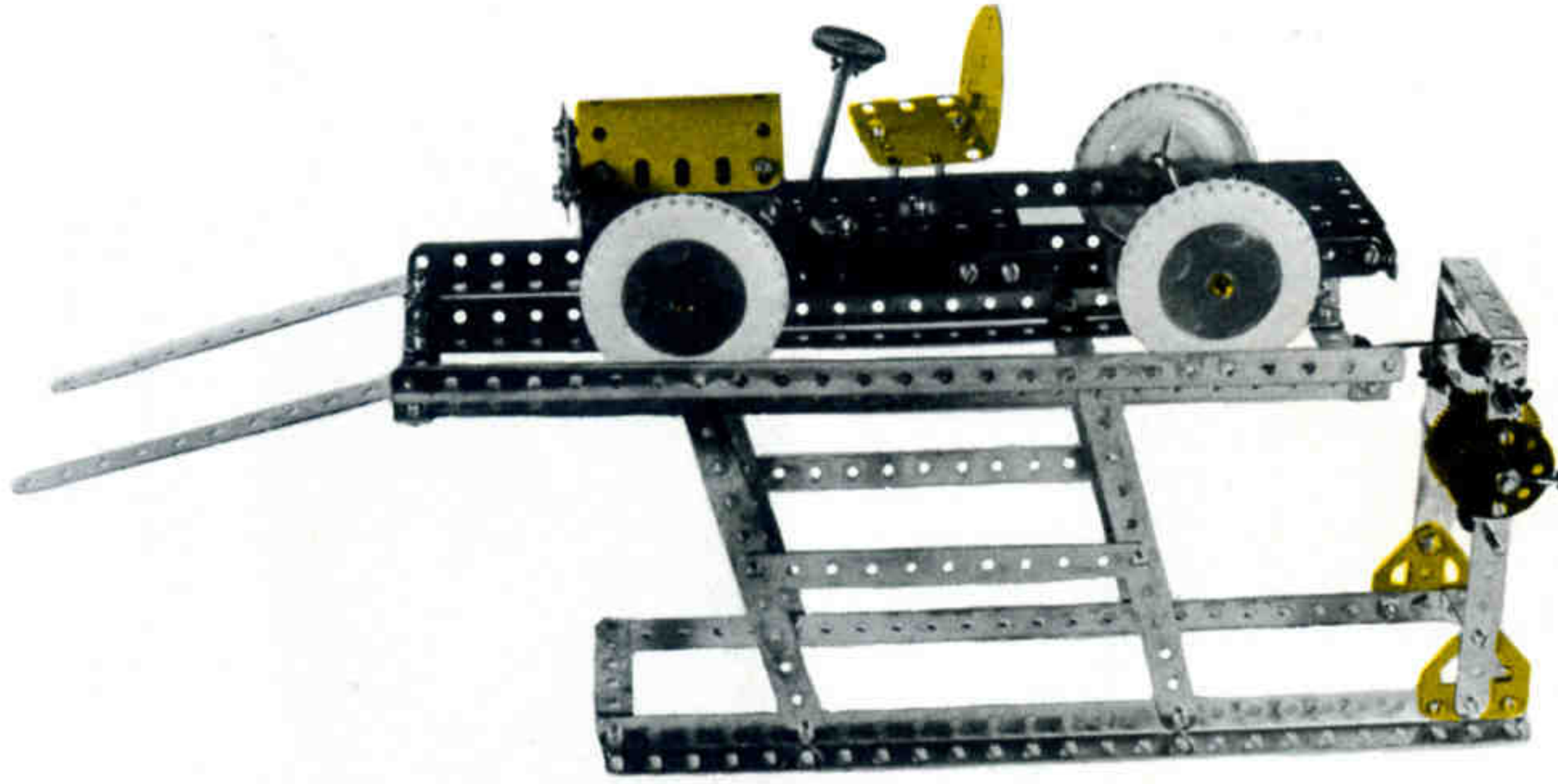

**ELEVADOR DE AUTOMOVILES 5/254**

4 - 1	1 - 19a	2 - 38d	1 - 147b
12 - 2	1 - 22	1 - 40	1 - 155
4 - 5	1 - 23	1 - 48	1 - 176
1 - 6a	1 - 24	3 - 48a	4 - 187
4 - 8	1 - 26	1 - 51	1 - 188
1 - 11	1 - 27a	1 - 52	1 - 199
1 - 11a	8 - 35	1 - 80c	1 - 214
6 - 12	84 - 37a	4 - 125	1 - 235
5 - 12c	72 - 37b	1 - 126	
4 - 16	12 - 38	2 - 126a	

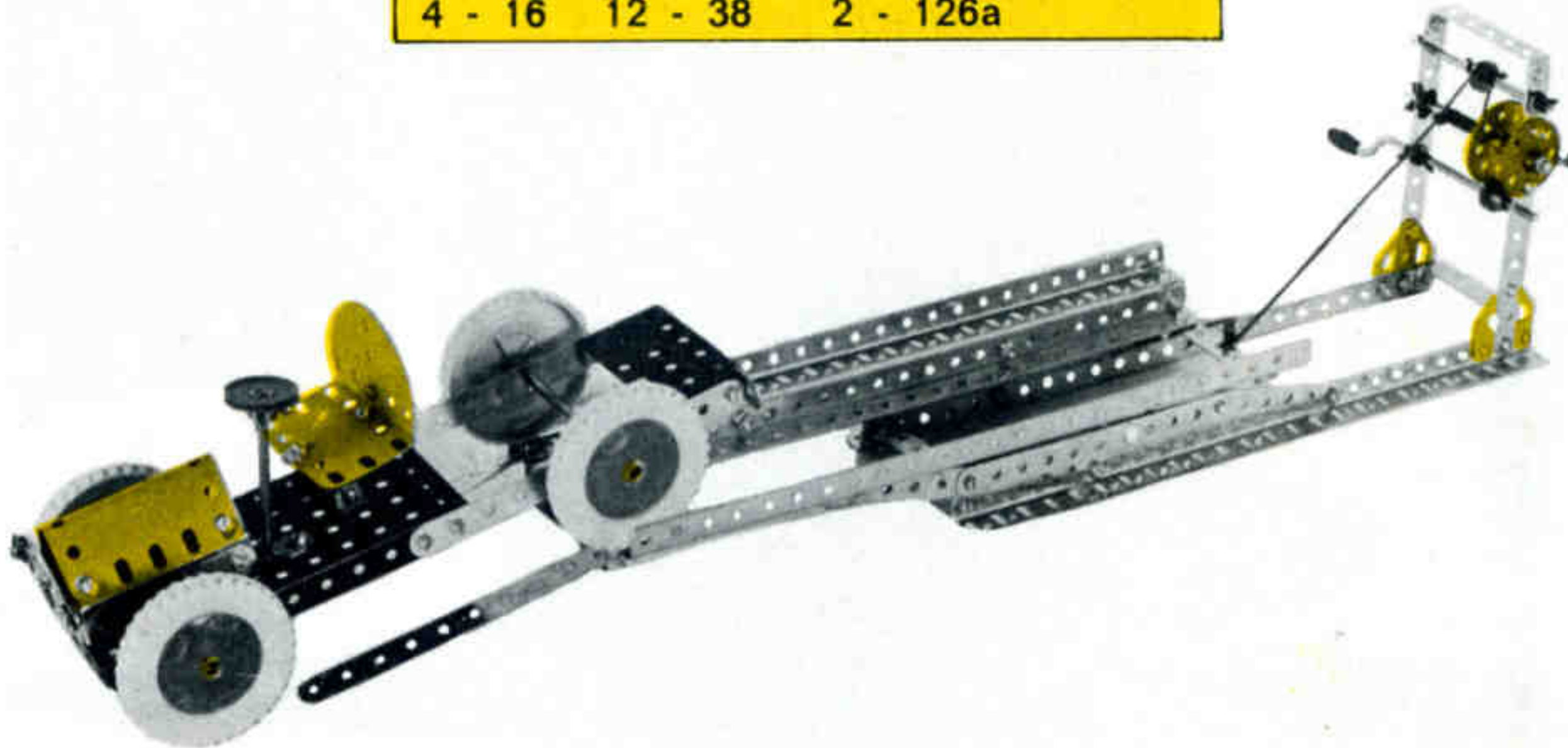
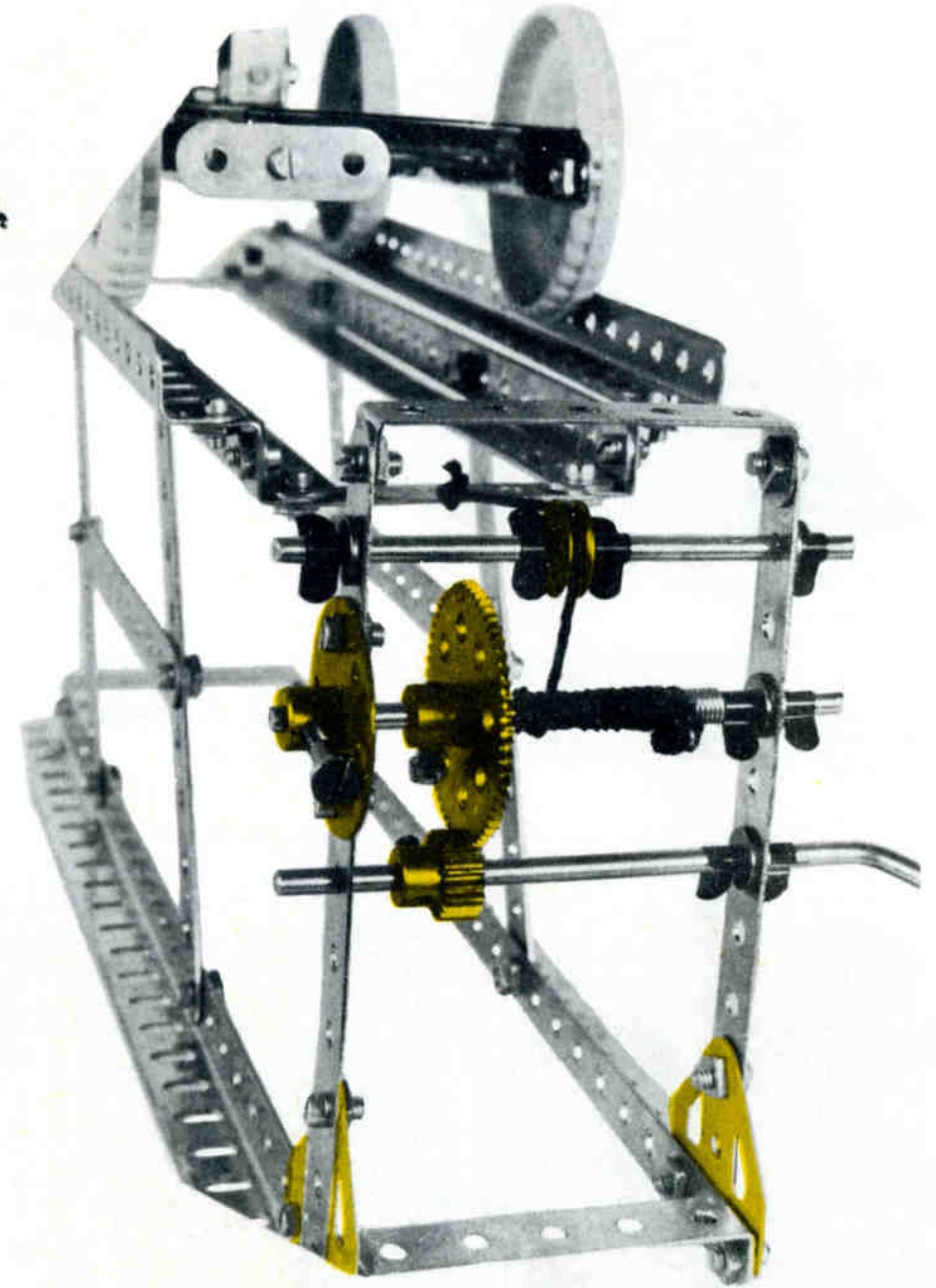



**MONTACARGAS DE MINA**  
5/255

6 - 1	80 - 37b	2 - 99
12 - 2	10 - 38	2 - 126
4 - 8	1 - 40	1 - 147b
8 - 12	6 - 48a	1 - 186
2 - 16	1 - 51	1 - 190
1 - 19b	1 - 52	1 - 191
1 - 19a	2 - 53a	4 - 192
6 - 35	1 - 91	39 - 374
80 - 37a	1 - 92	



**BOBSLEIGH 5/256**

3 - 1	2 - 12c	3 - 190
8 - 2	90 - 37a	2 - 191
2 - 4	90 - 37b	1 - 193a
4 - 5	3 - 90a	1 - 214
2 - 6a	4 - 125	2 - 215
2 - 8	4 - 188	4 - 235b
8 - 12	2 - 189	

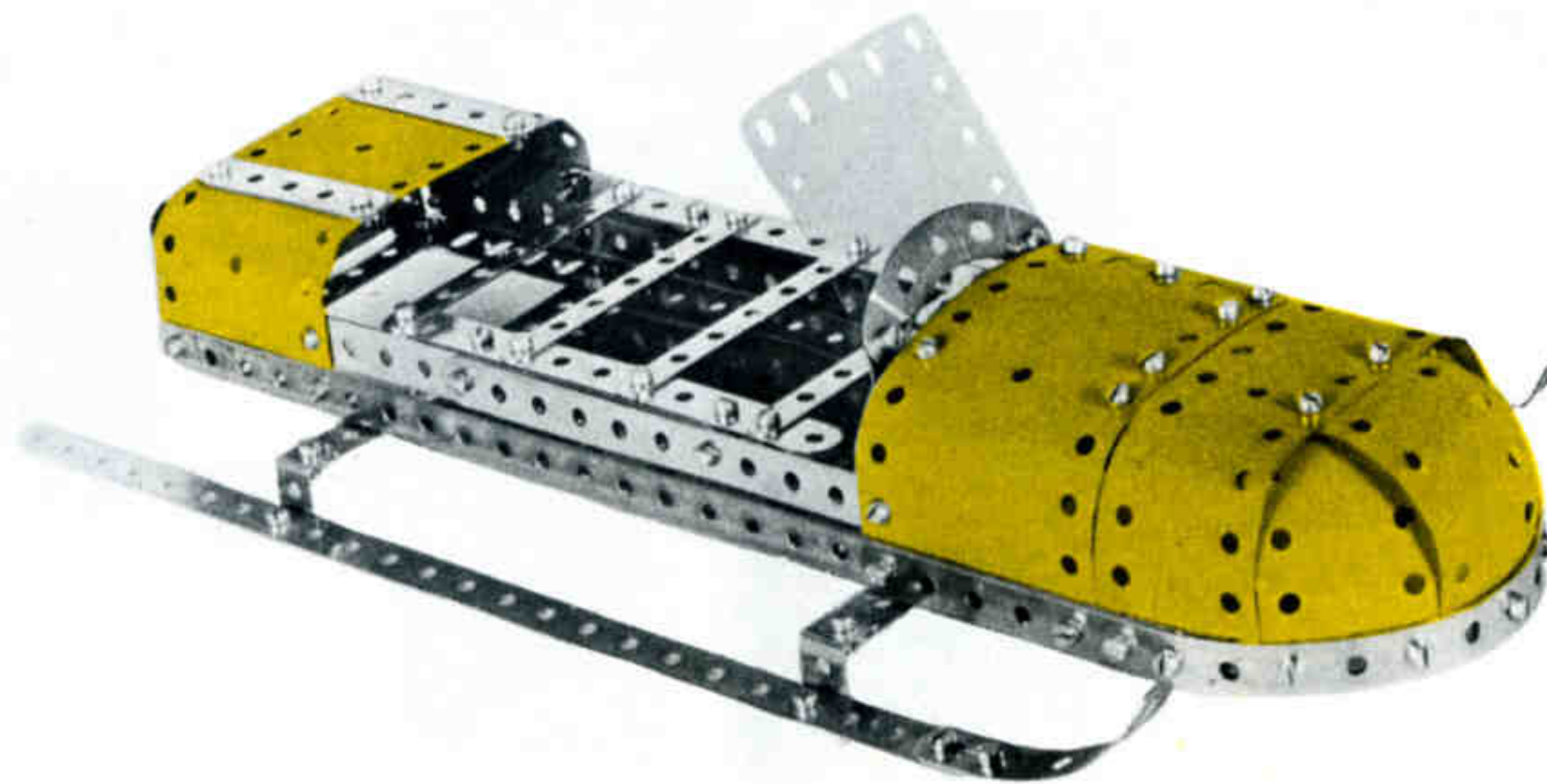

CAMION CHASIS 5/257				
12 - 2	2 - 15	4 - 38	1 - 155	2 - 212
4 - 5	1 - 15a	2 - 38d	4 - 187	1 - 213
2 - 6a	1 - 17	2 - 48a	2 - 188	2 - 212a
2 - 8	2 - 18a	1 - 52	4 - 189	2 - 221
1 - 10	1 - 22	4 - 90a	3 - 192	4 - 235a
1 - 11a	6 - 35	2 - 125	2 - 193a	4 - 235b
12 - 12	96 - 37a	2 - 126	1 - 193c	
1 - 12c	96 - 37b	2 - 126a	1 - 193e	

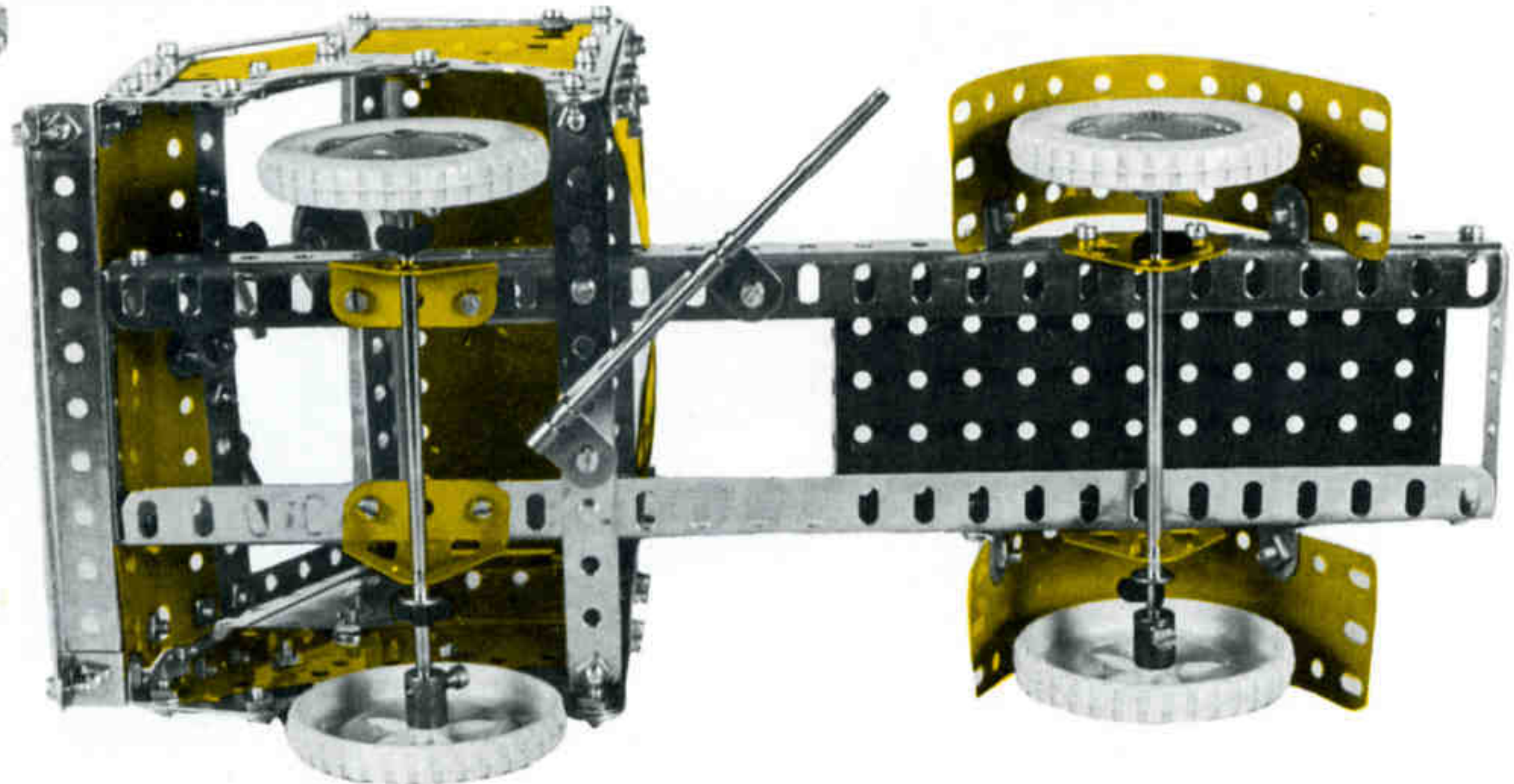
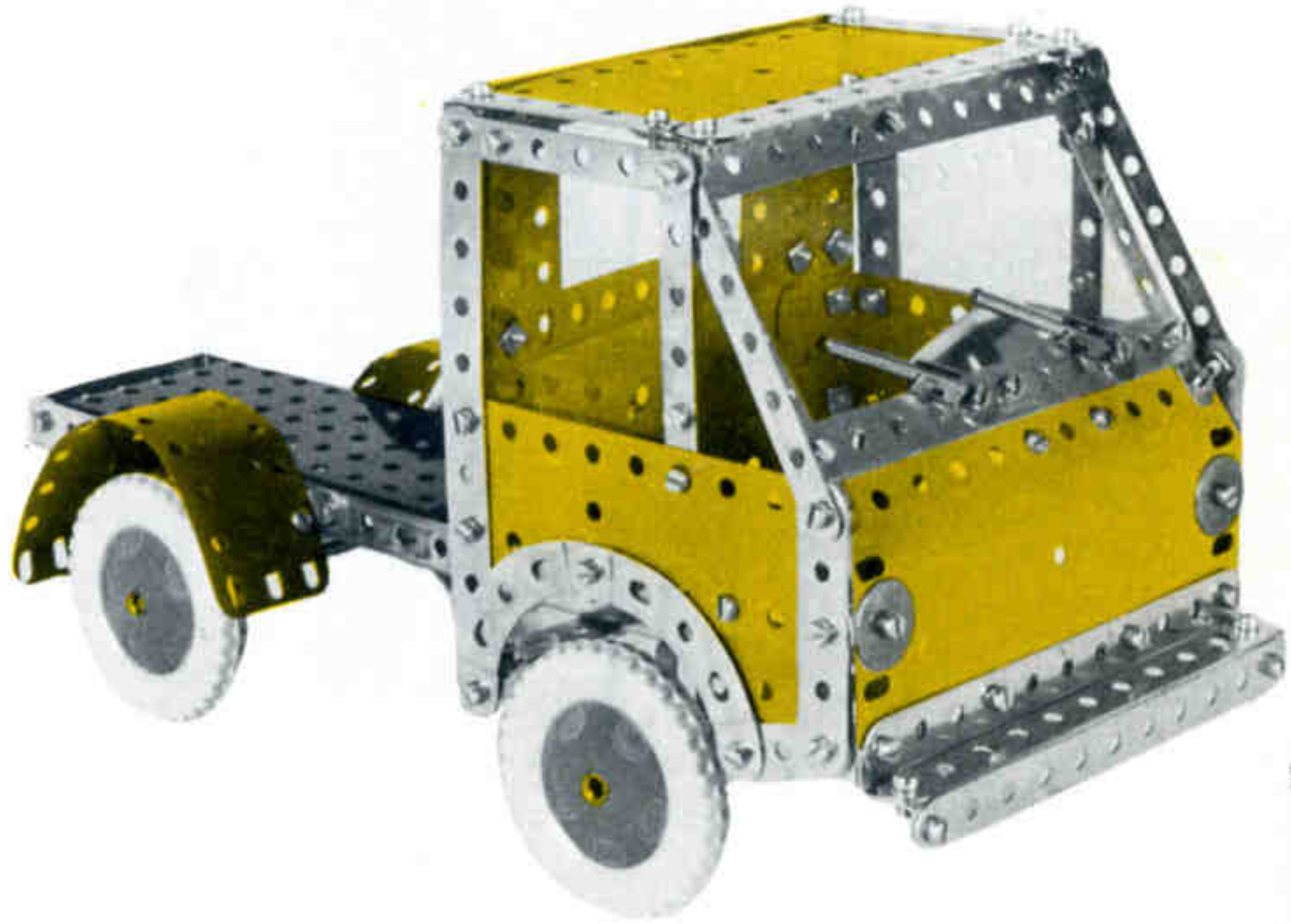
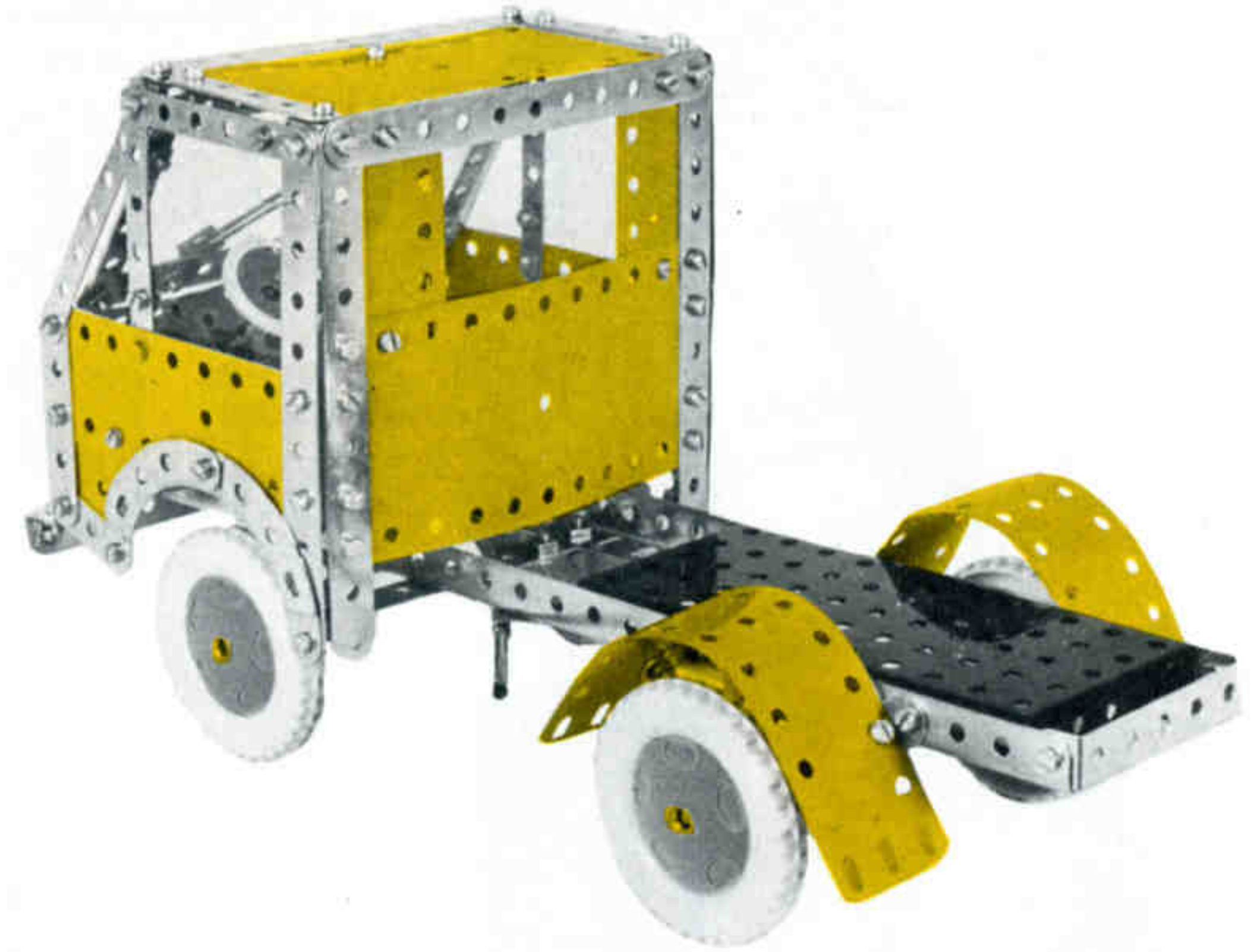



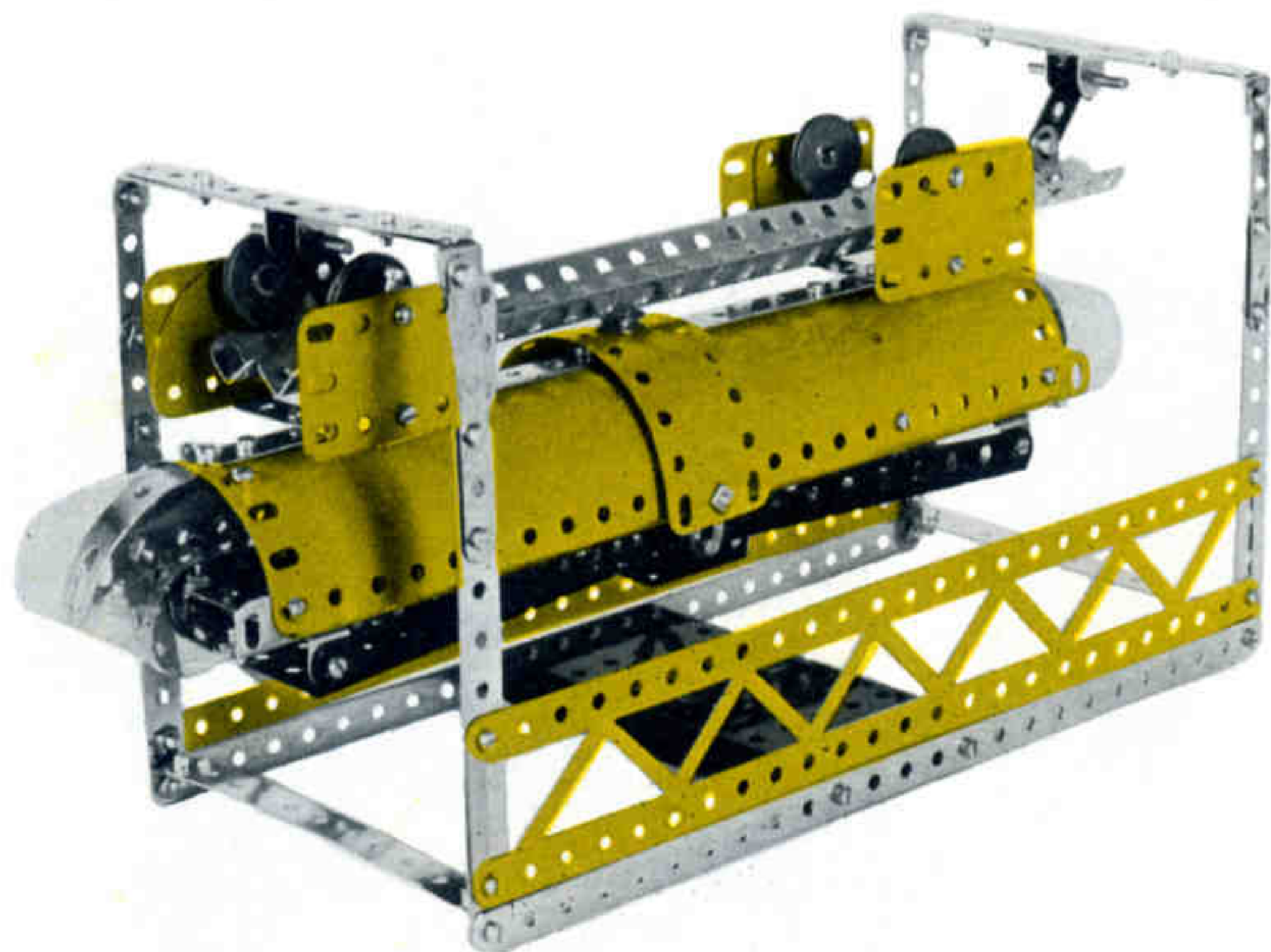

TREN AEREO 5/258			
3 - 1	1 - 23	1 - 53	1 - 189
8 - 2	4 - 35	2 - 54	2 - 214
2 - 6a	68 - 37a	1 - 80c	2 - 215
4 - 8	75 - 37b	2 - 99	4 - 235a
2 - 10	6 - 48a	2 - 126a	
4 - 12c	1 - 51	2 - 153c	
4 - 22	1 - 52	4 - 188	

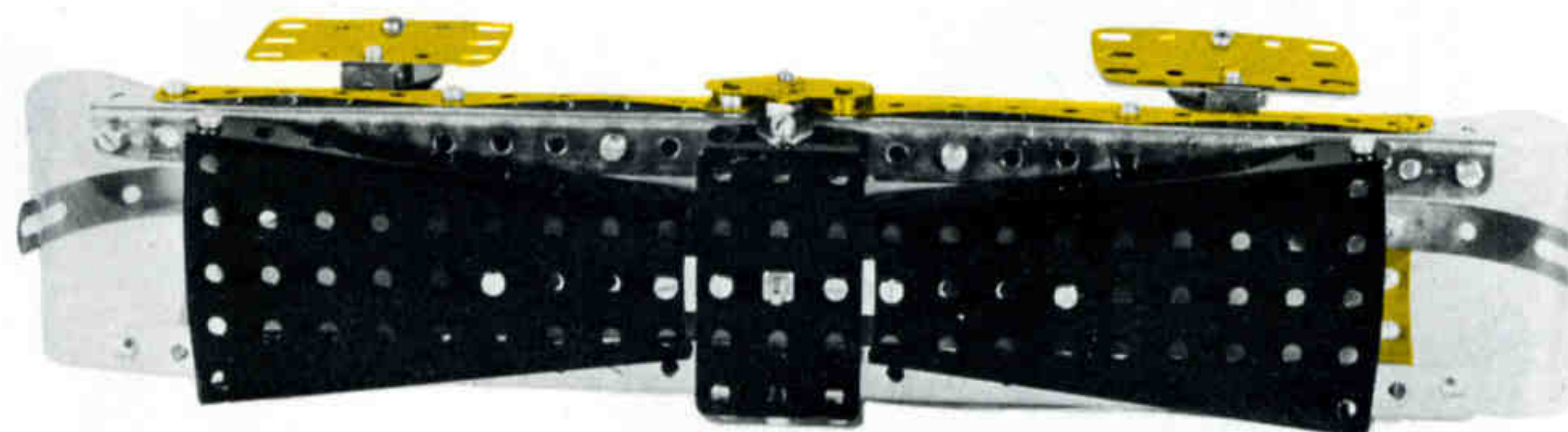
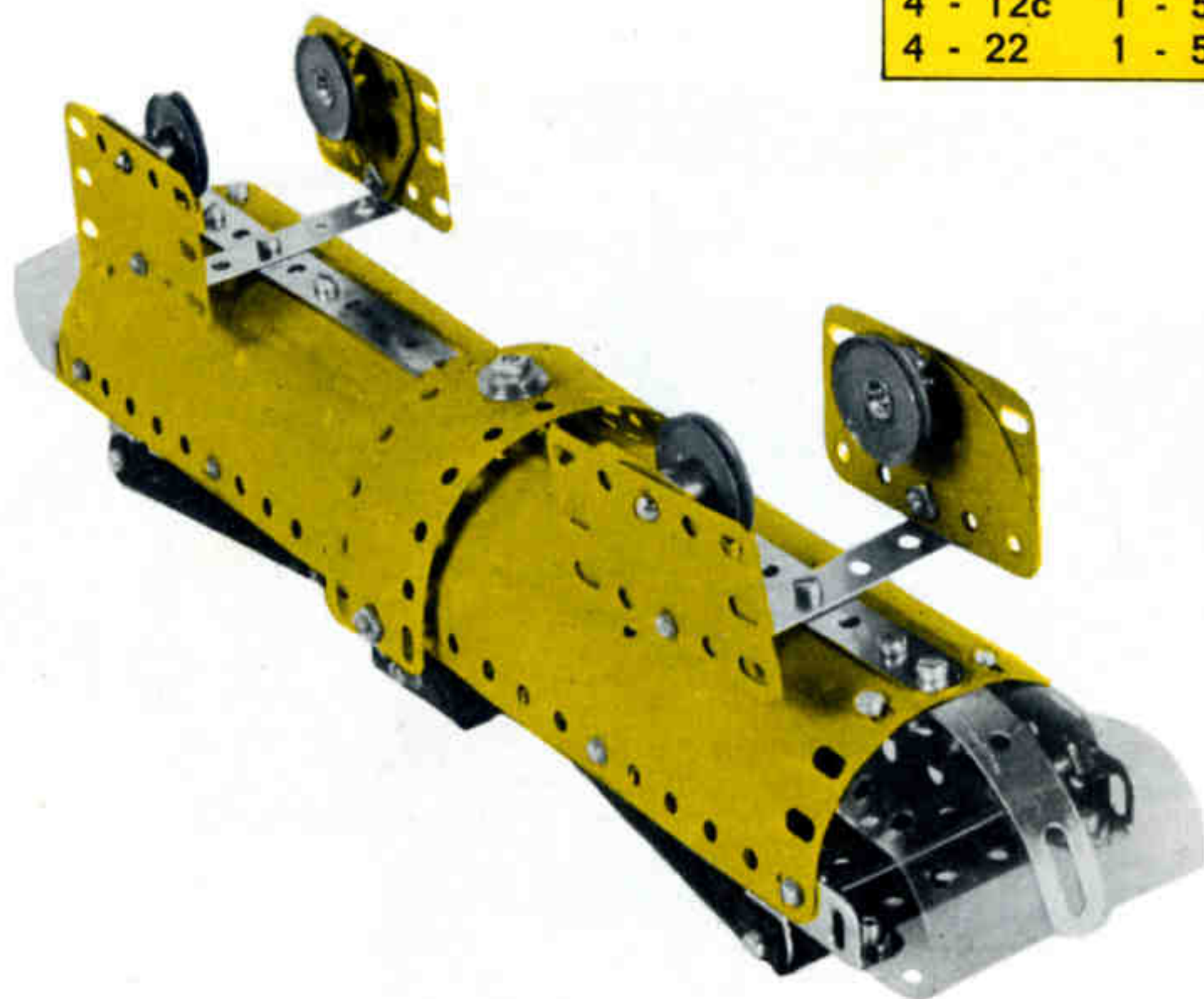

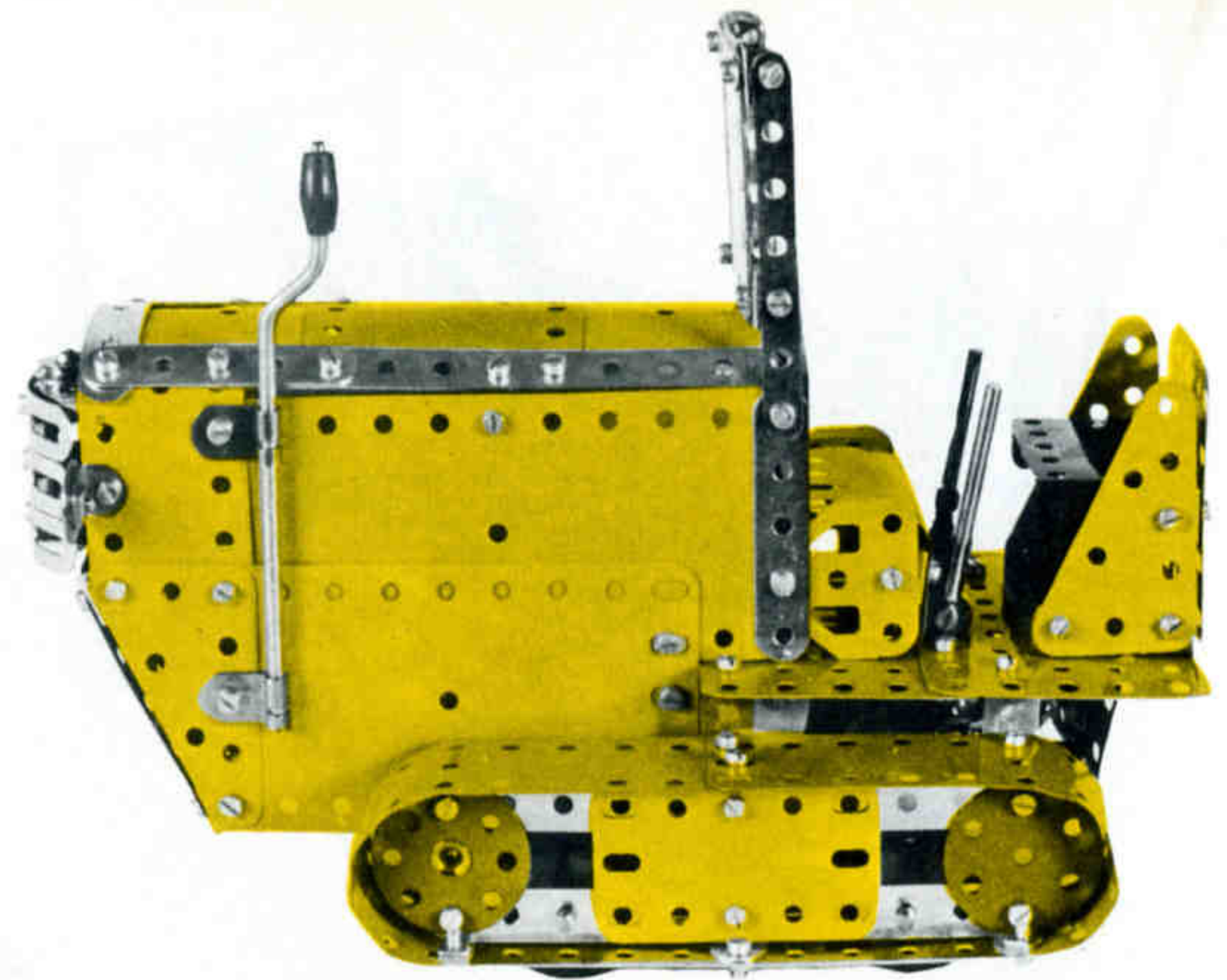
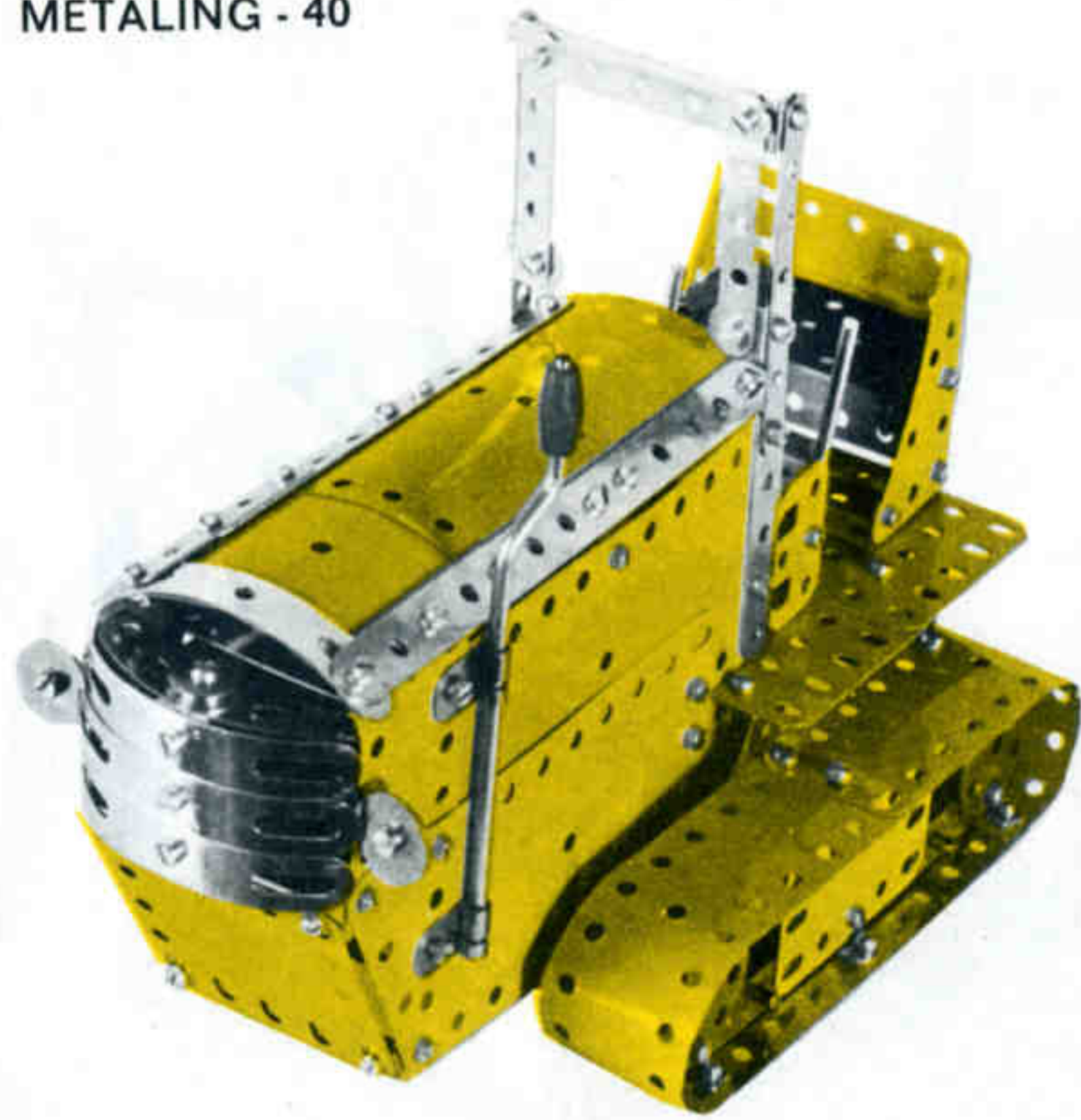

TRACTOR ORUGA  
5/259

10 - 2	3 - 111c
4 - 5	4 - 125
4 - 11	1 - 126
12 - 12	2 - 126a
3 - 12c	4 - 142c
2 - 12a	4 - 188
2 - 17	4 - 189
4 - 18a	4 - 190
1 - 19g	2 - 191
1 - 23	2 - 192
4 - 22	1 - 193a
2 - 24	2 - 194
2 - 24c	1 - 199
118 - 37a	1 - 200
110 - 37b	2 - 212a
2 - 38d	2 - 212
1 - 48	2 - 214
7 - 48a	4 - 215
1 - 51	4 - 221
1 - 52	3 - 235
2 - 53a	2 - 235b
1 - 90a	

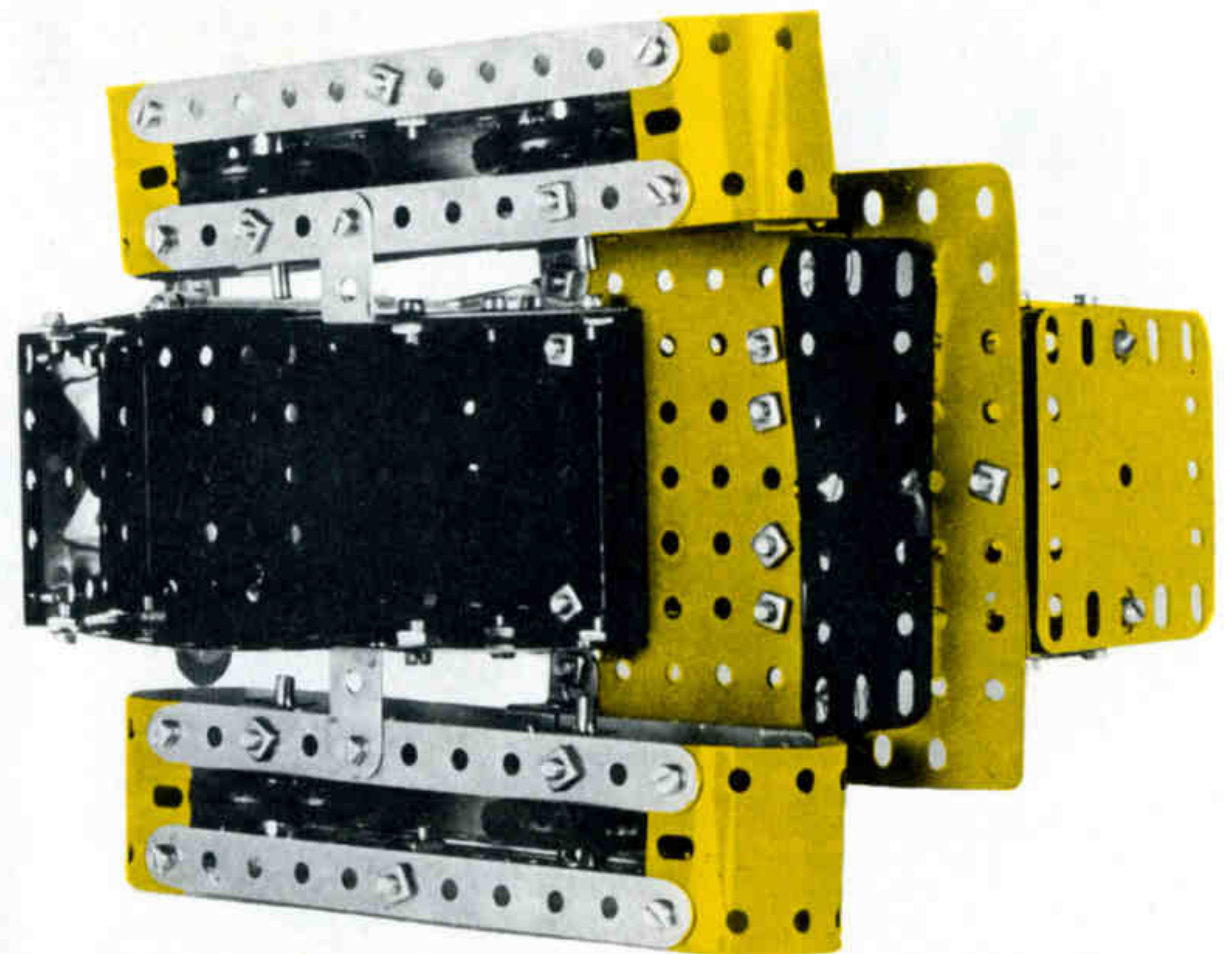
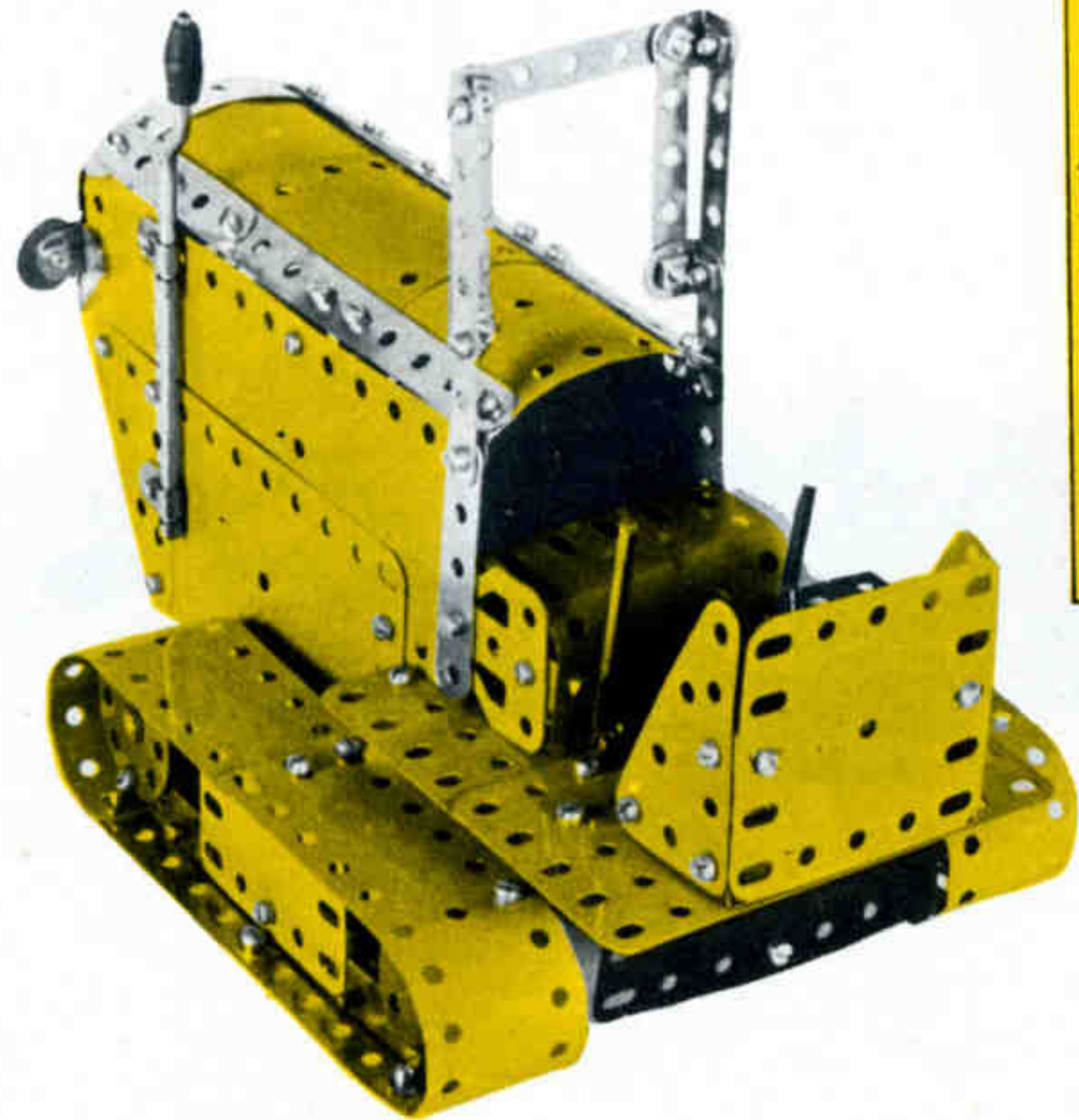

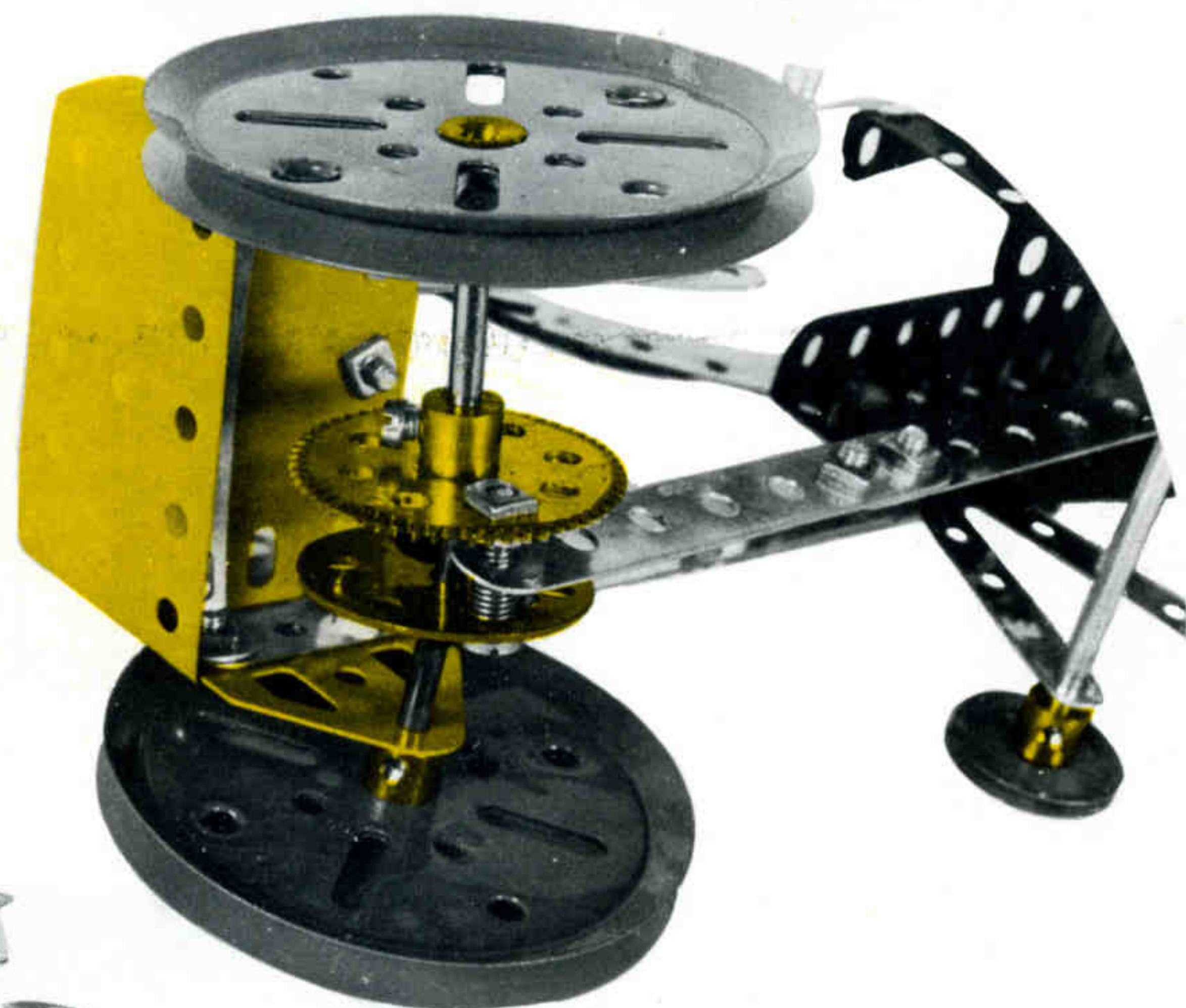
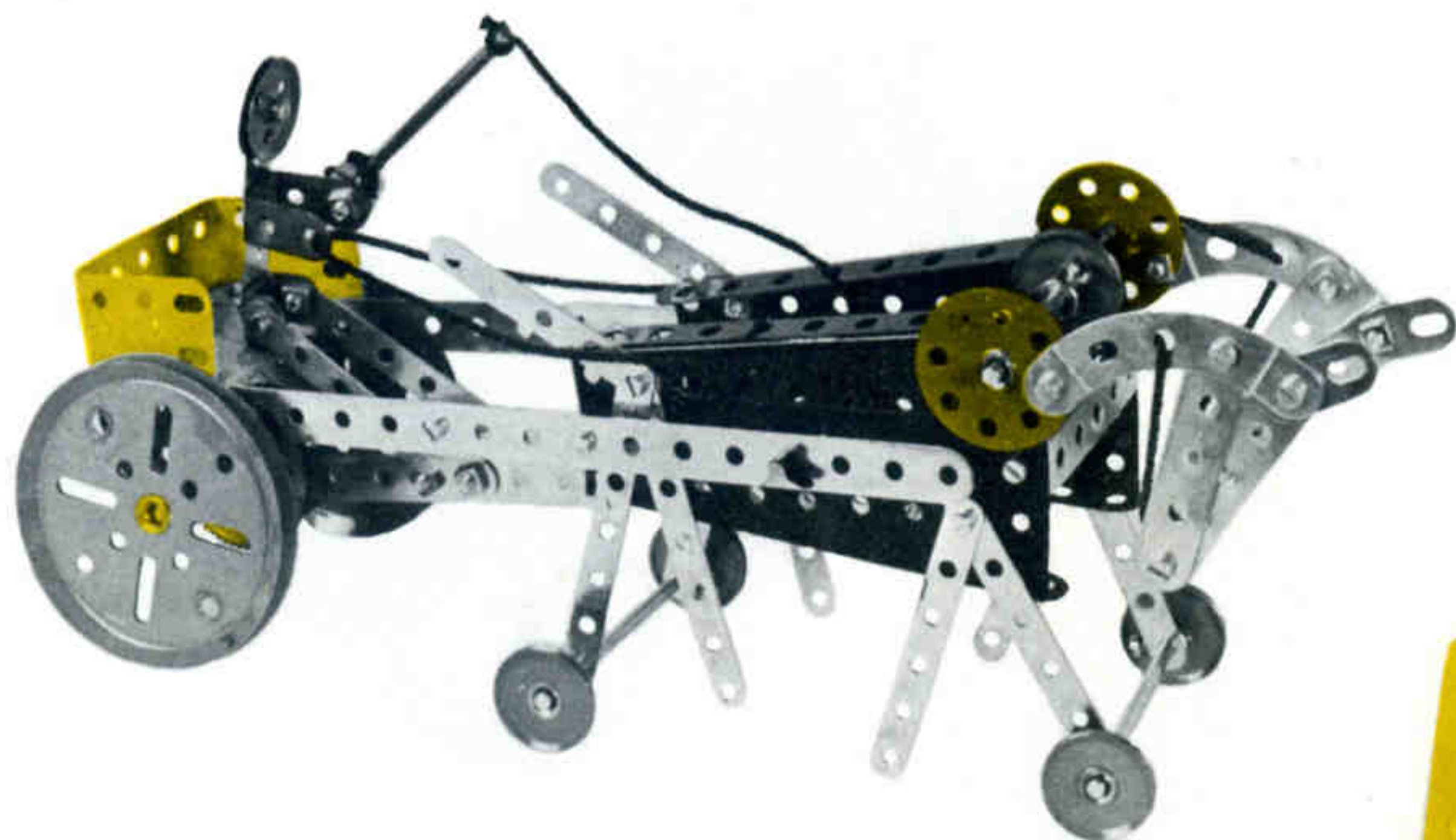

**CABALLOS CON MOVIMIENTO 5/260**

5 - 2	4 - 16	8 - 35	2 - 126a
1 - 3	2 - 18a	36 - 37a	1 - 147b
6 - 5	2 - 19b	36 - 37b	1 - 176
2 - 10	5 - 22	1 - 38	1 - 188
1 - 11	1 - 22a	1 - 40	1 - 189
1 - 11a	2 - 24	2 - 48a	4 - 235
3 - 12	1 - 24c	2 - 54	4 - 235a
1 - 15b	1 - 27a	2 - 90a	4 - 235b

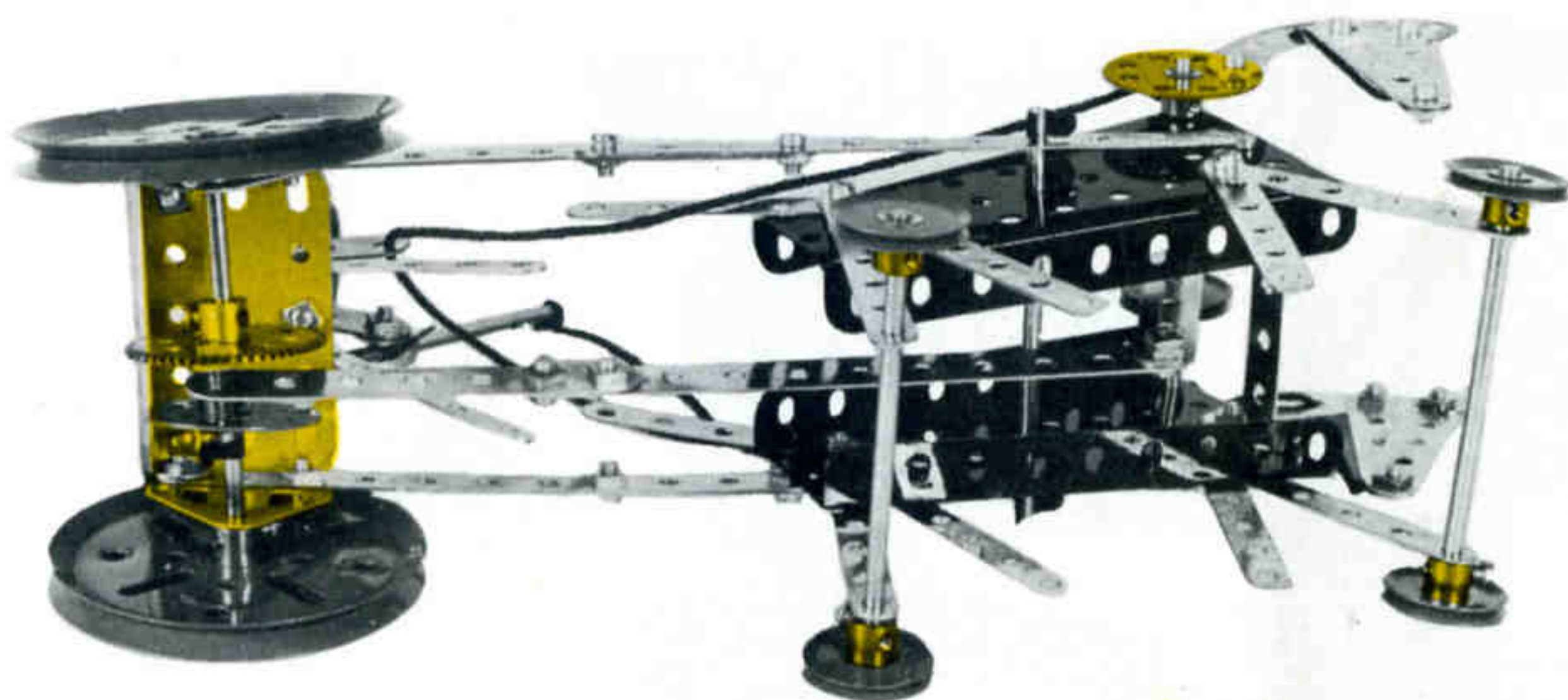

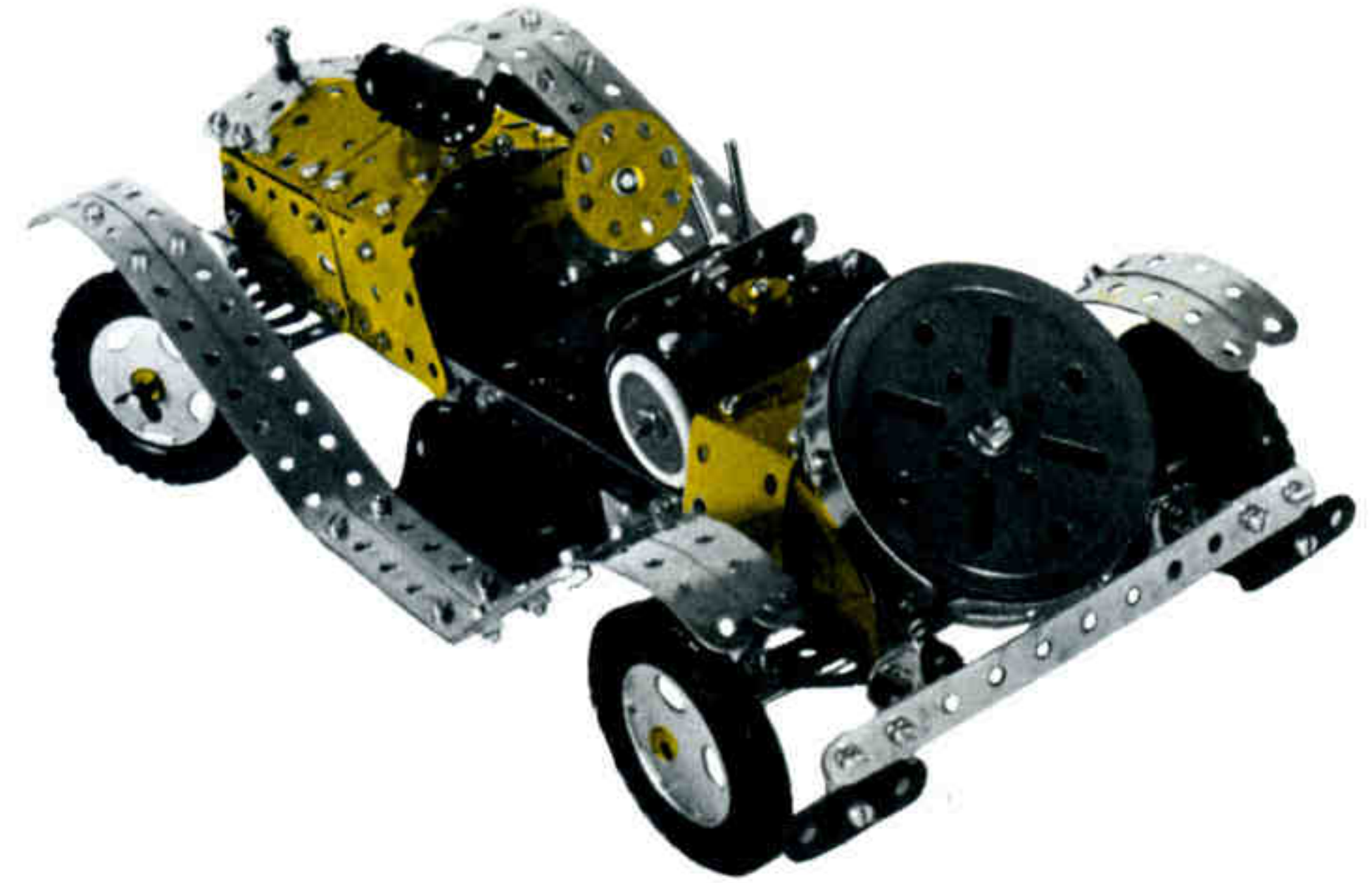

**AUTOMOVIL "AÑOS 20" 5/261**

4 - 1a	1 - 15	2 - 35	2 - 155	2 - 221	1 - 213
5 - 2	2 - 17	100 - 37a	4 - 187	2 - 126	2 - 125
4 - 5	2 - 19b	100 - 37b	4 - 215	2 - 126a	1 - 80c
2 - 6a	2 - 22	1 - 48	1 - 194	4 - 235	
2 - 8	1 - 23	5 - 48a	3 - 194a	1 - 147b	
6 - 10	1 - 24	1 - 51	2 - 214	2 - 212	
3 - 12	1 - 26	1 - 52	4 - 188	2 - 212a	
2 - 12c	2 - 18a	2 - 53a	2 - 189	2 - 235b	

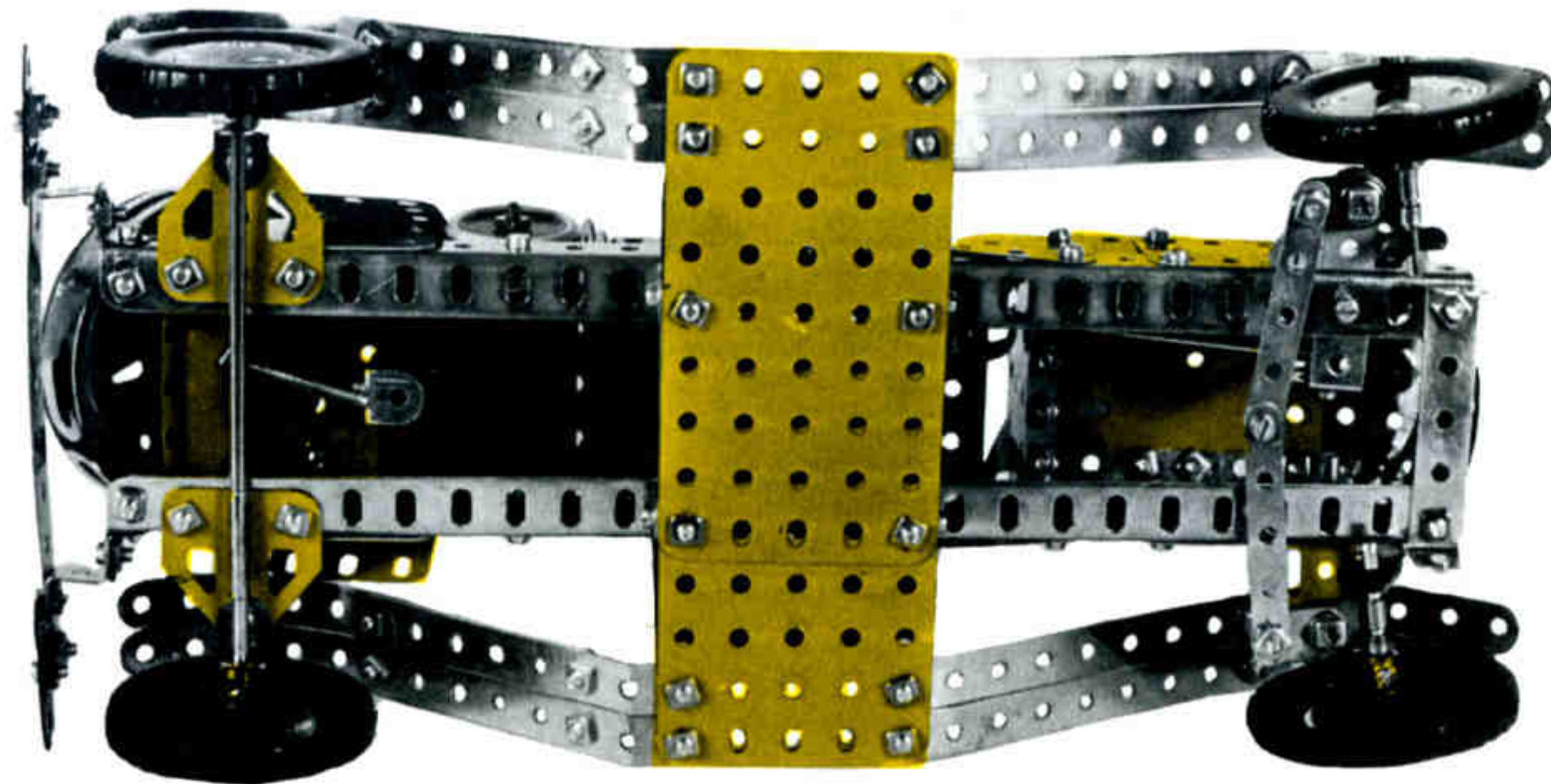

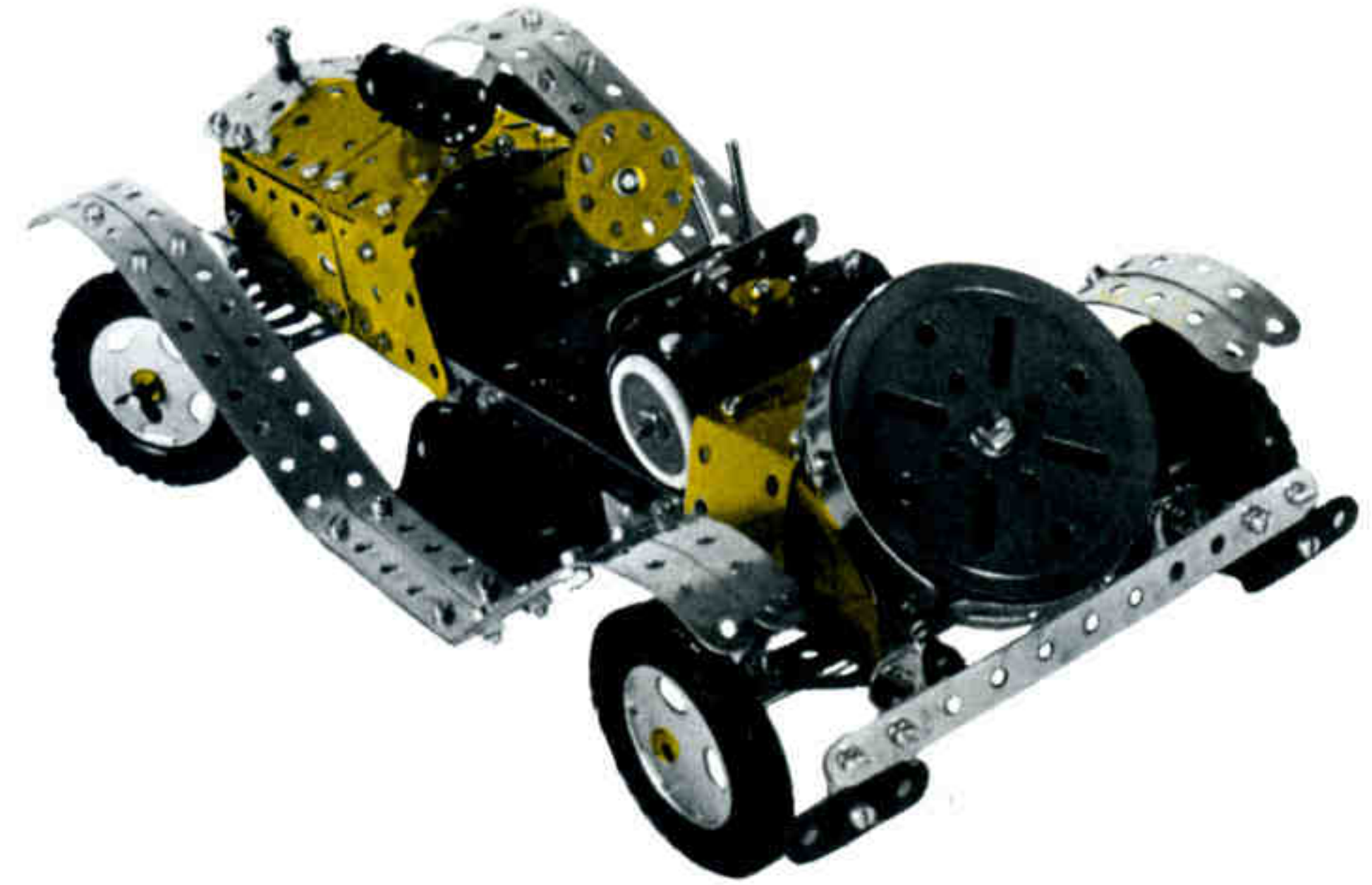
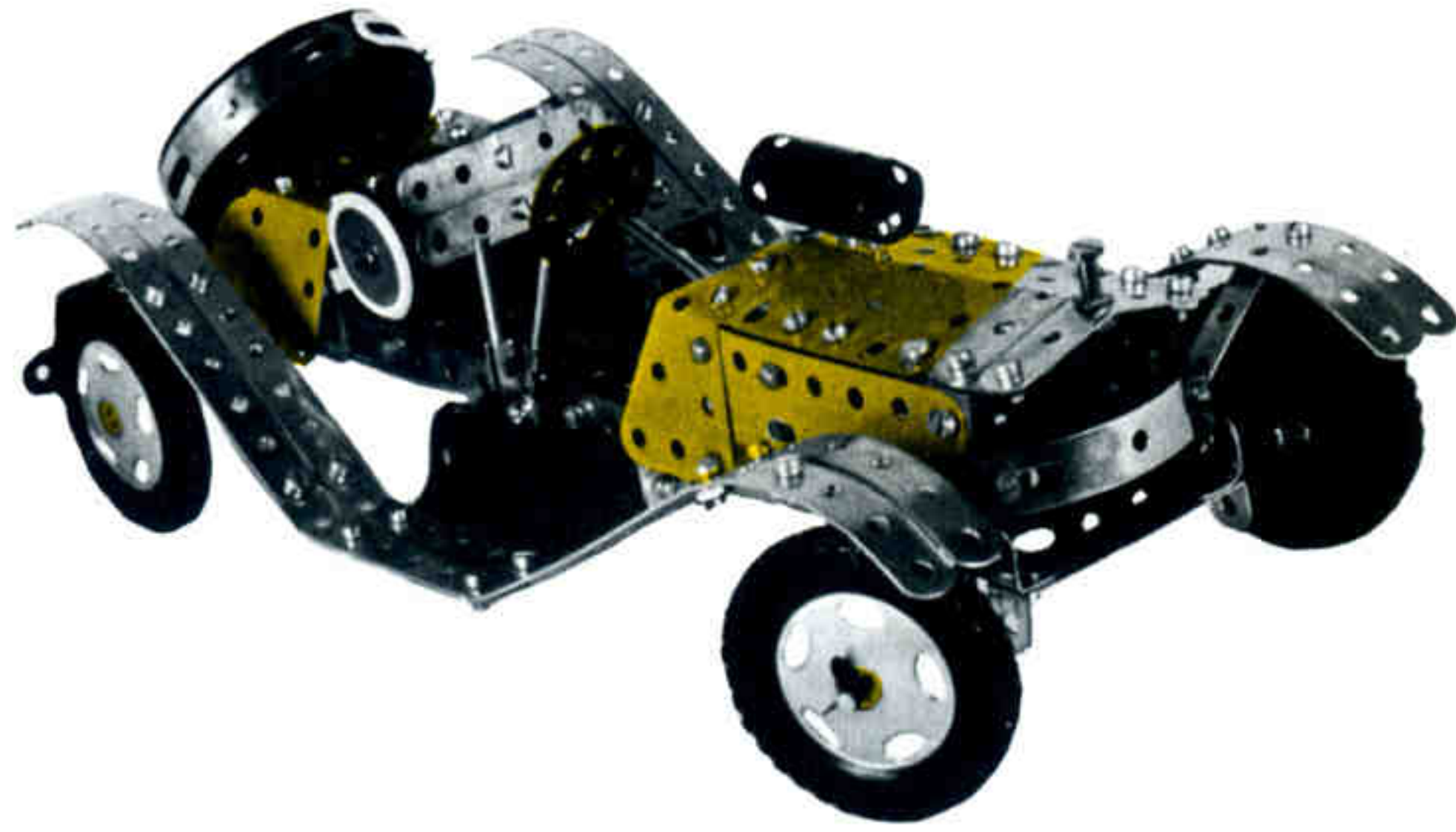

**AUTOMOVIL "AÑOS 20" 5/261**

4 - 1a	1 - 15	2 - 35	2 - 155	2 - 221	1 - 213
5 - 2	2 - 17	100 - 37a	4 - 187	2 - 126	2 - 125
4 - 5	2 - 19b	100 - 37b	4 - 215	2 - 126a	1 - 80c
2 - 6a	2 - 22	1 - 48	1 - 194	4 - 235	
2 - 8	1 - 23	5 - 48a	3 - 194a	1 - 147b	
6 - 10	1 - 24	1 - 51	2 - 214	2 - 212	
3 - 12	1 - 26	1 - 52	4 - 188	2 - 212a	
2 - 12c	2 - 18a	2 - 53a	2 - 189	2 - 235b	

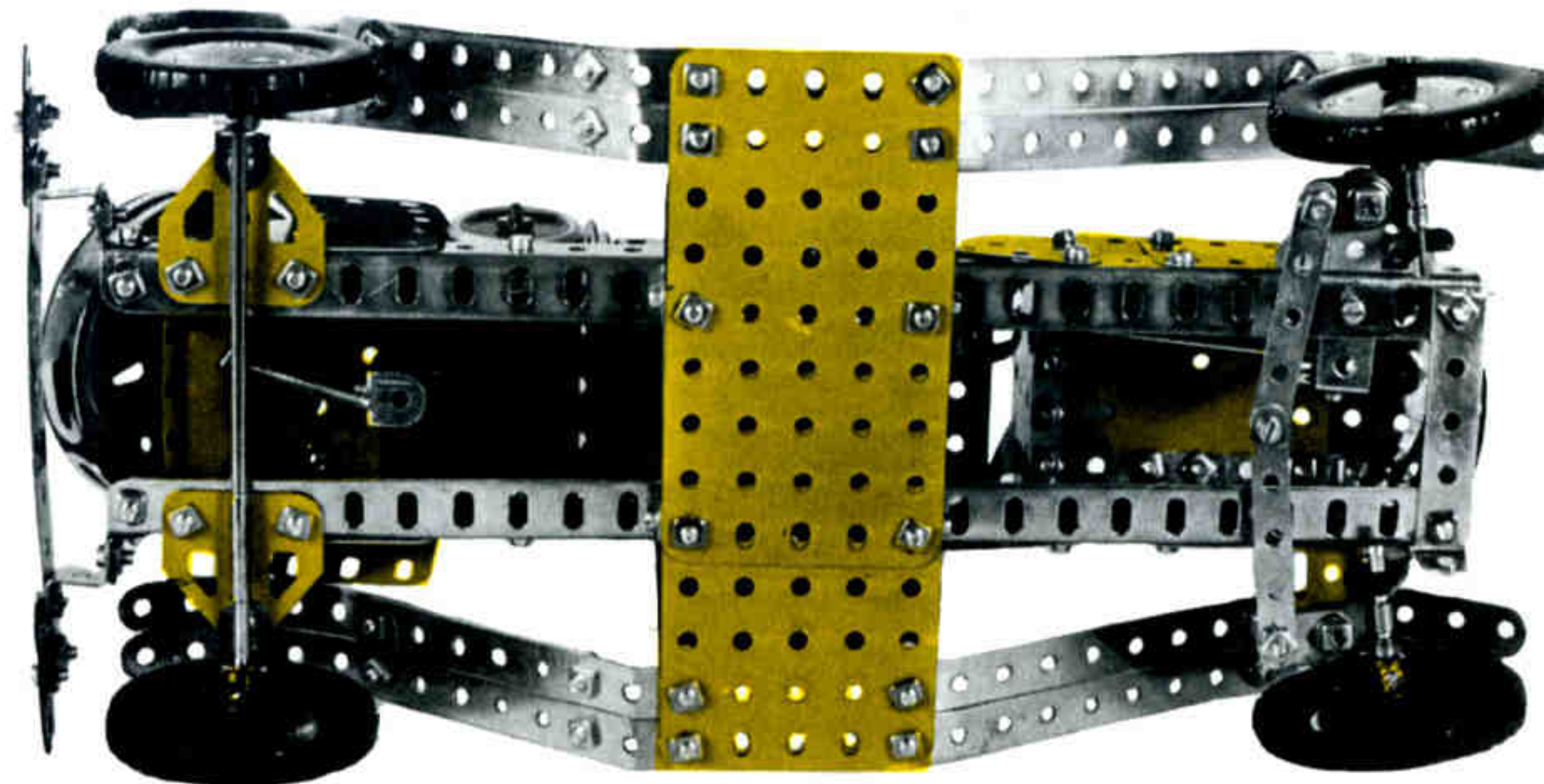

AUTOMOVIL ANTIGUO 5/262	
5 - 2	1 - 52
9 - 5	1 - 53a
2 - 6a	1 - 80c
2 - 8	2 - 111c
2 - 10	1 - 126
9 - 12	1 - 155
2 - 12a	4 - 187
6 - 12c	4 - 188
2 - 15	4 - 189
5 - 22	2 - 191
2 - 22a	3 - 192
95 - 37a	1 - 193c
90 - 37b	2 - 194c
7 - 48a	4 - 235
1 - 51	

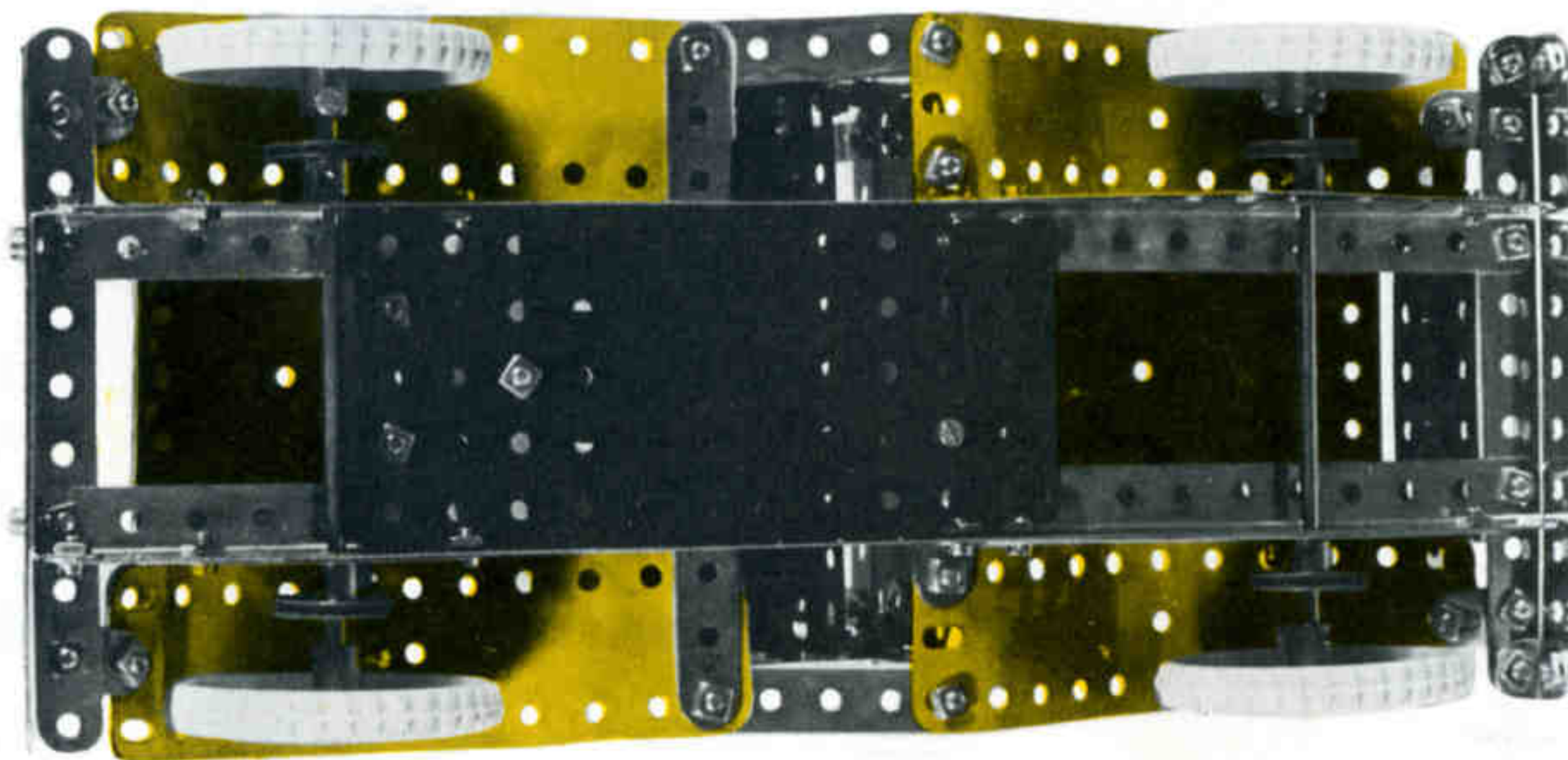
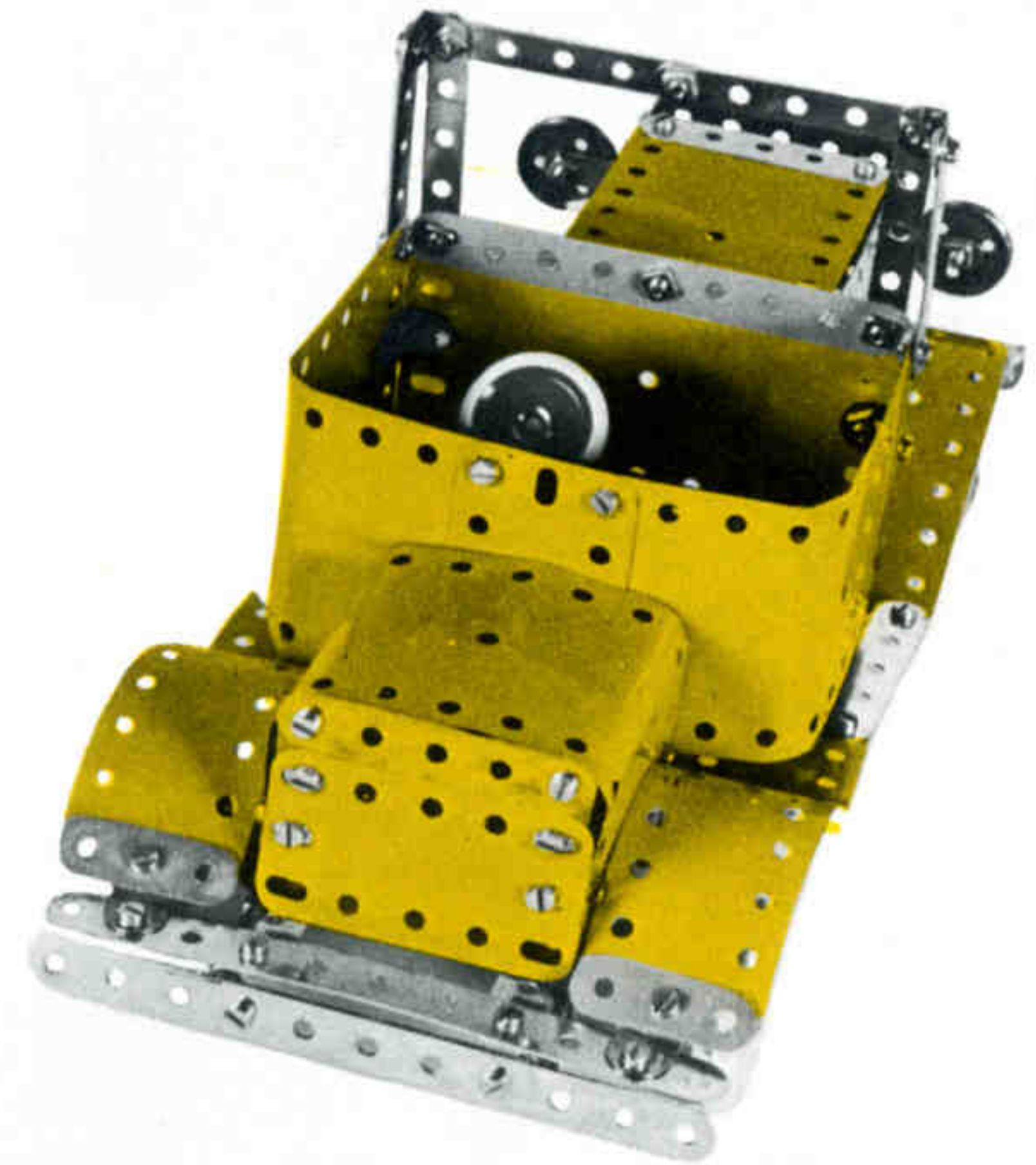
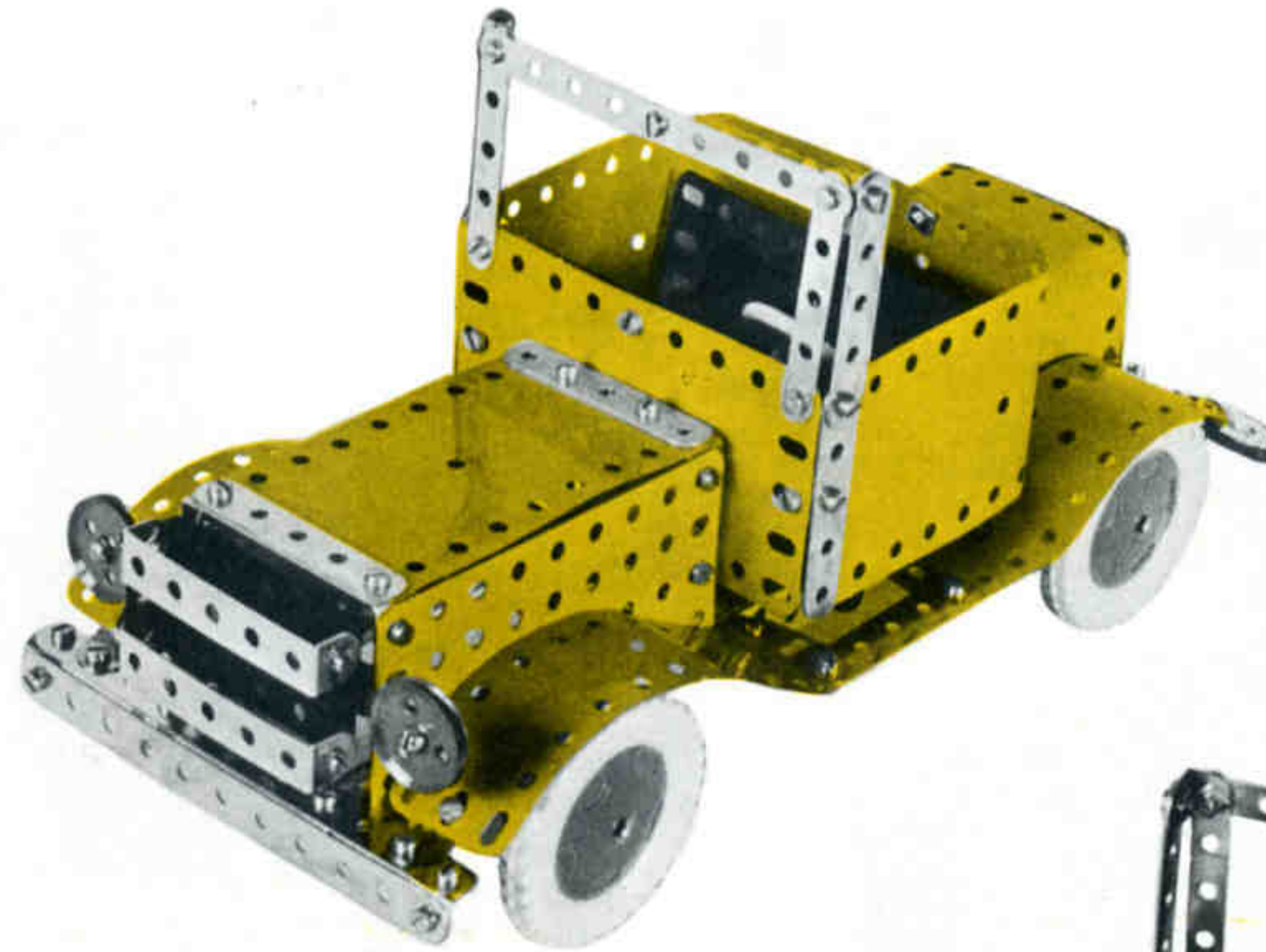

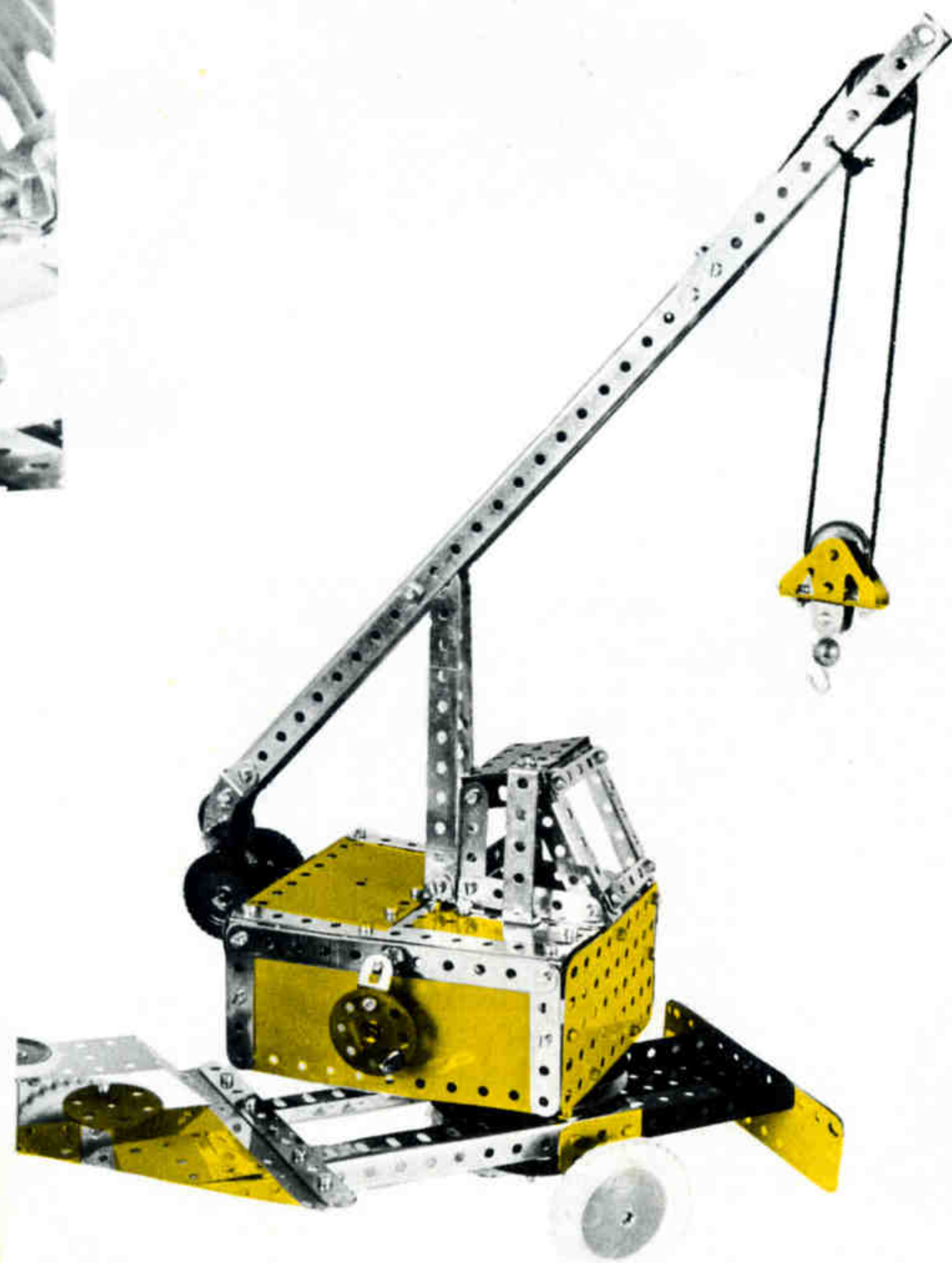
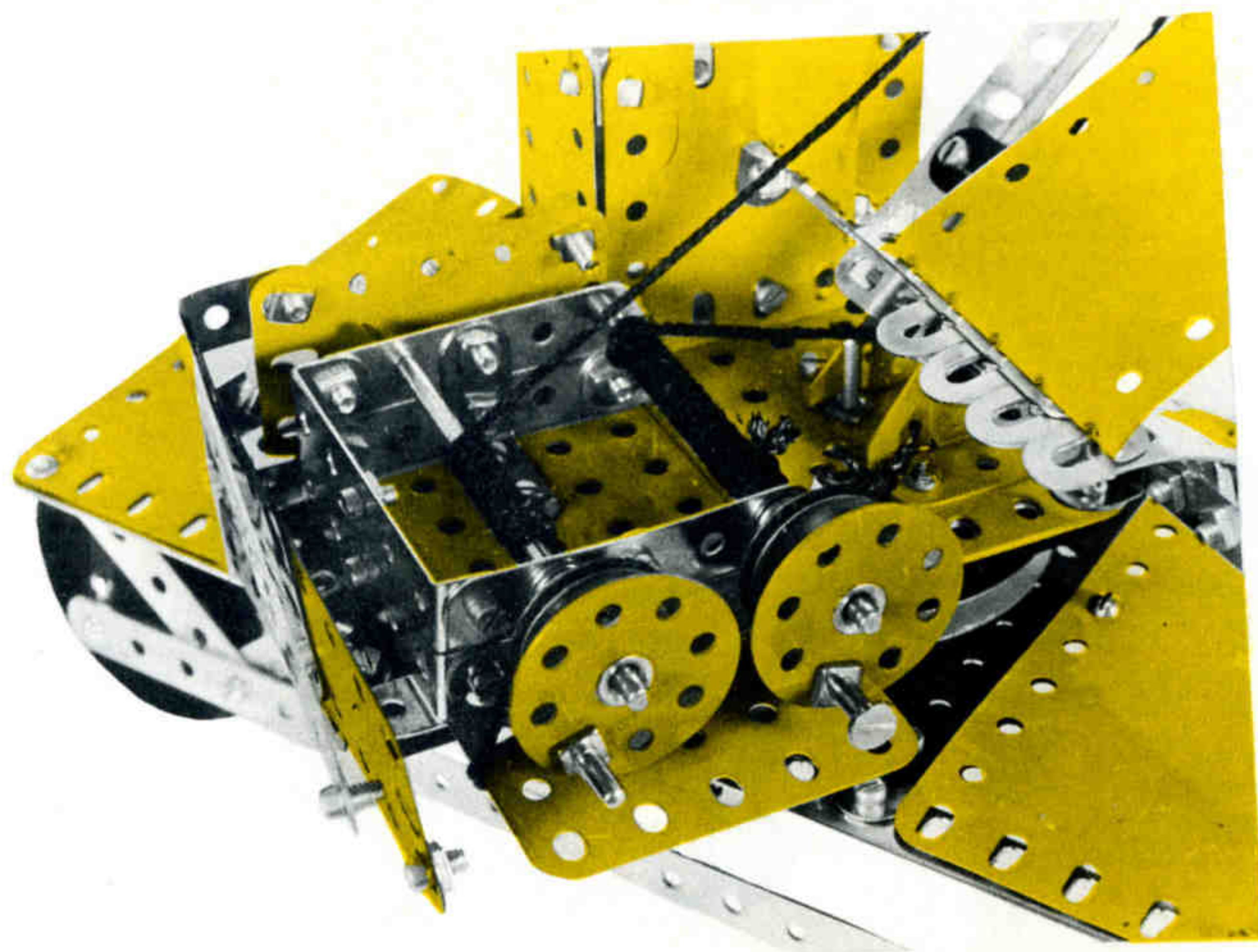
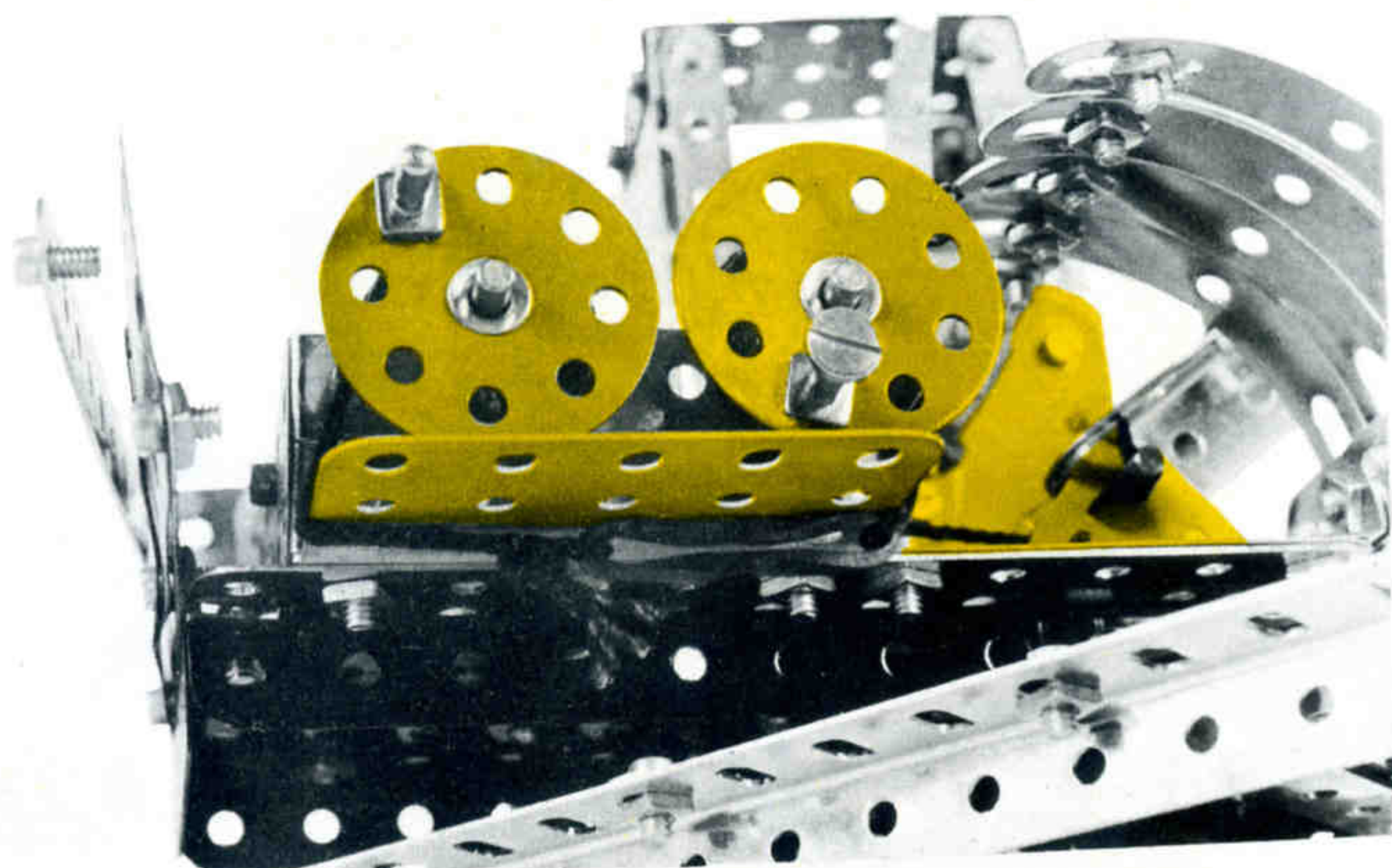

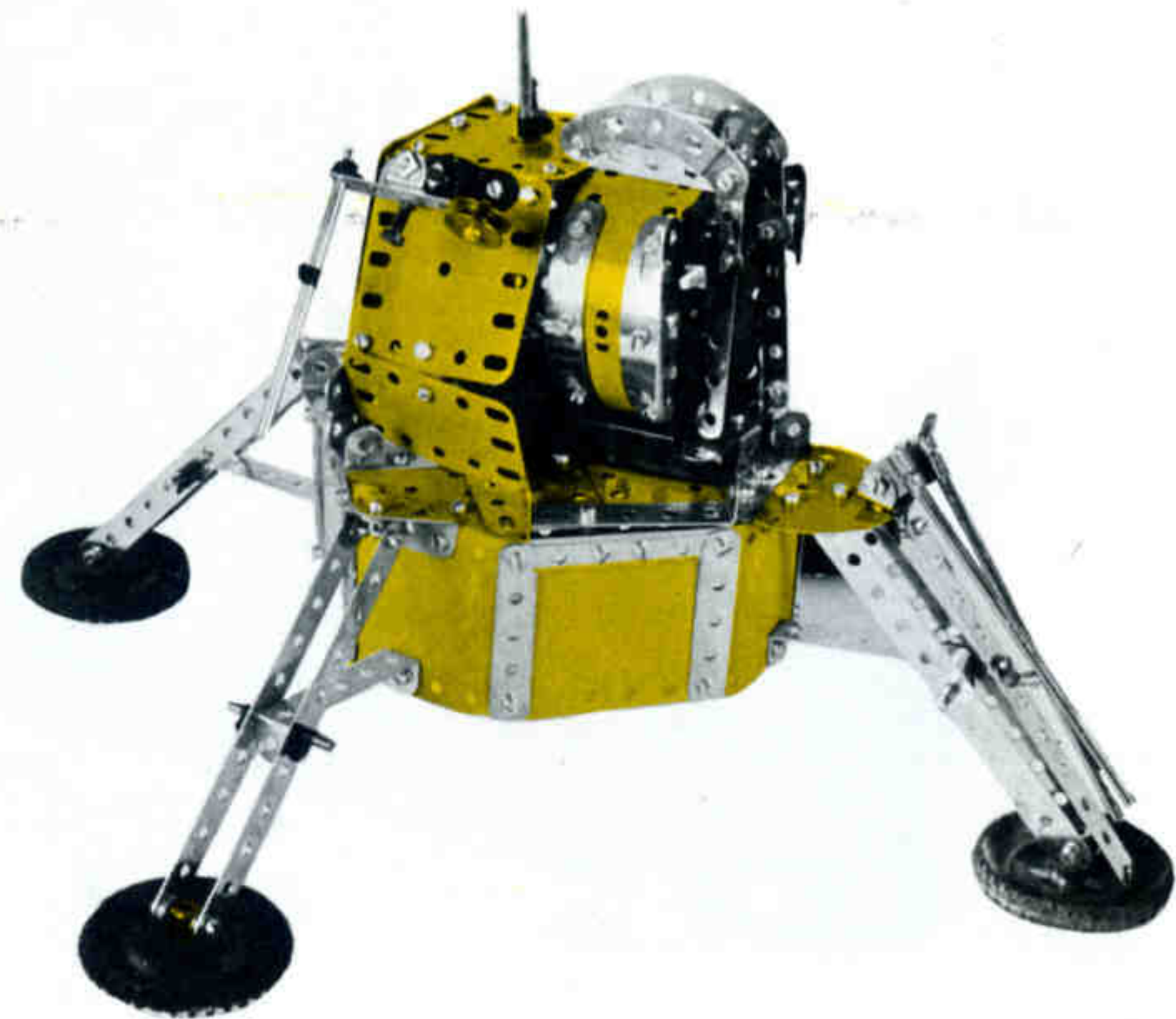
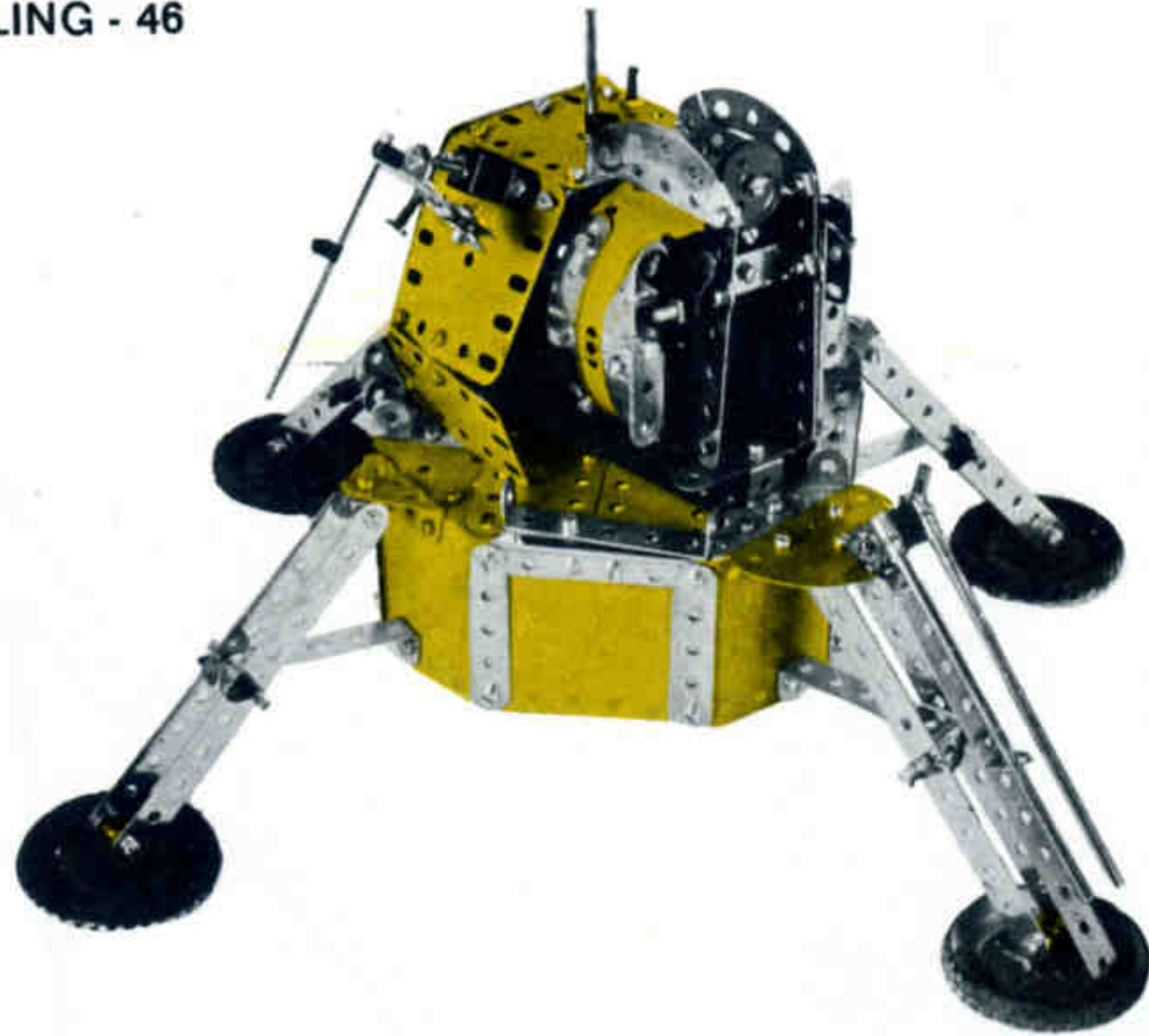

MODULO LUNAR 5/264		
11 - 2	1 - 48	1 - 214
11 - 5	8 - 48a	5 - 221
7 - 12	1 - 52	1 - 222
2 - 16	11 - 35	2 - 212a
4 - 18a	1 - 51	4 - 188
1 - 22a	2 - 90a	1 - 154a
1 - 23	3 - 125	1 - 235
2 - 15	3 - 126	4 - 235a
1 - 17	1 - 147b	2 - 235b
100 - 37a	4 - 187	4 - 192
100 - 37b	3 - 189	
2 - 38d	4 - 190	
1 - 45	4 - 215	

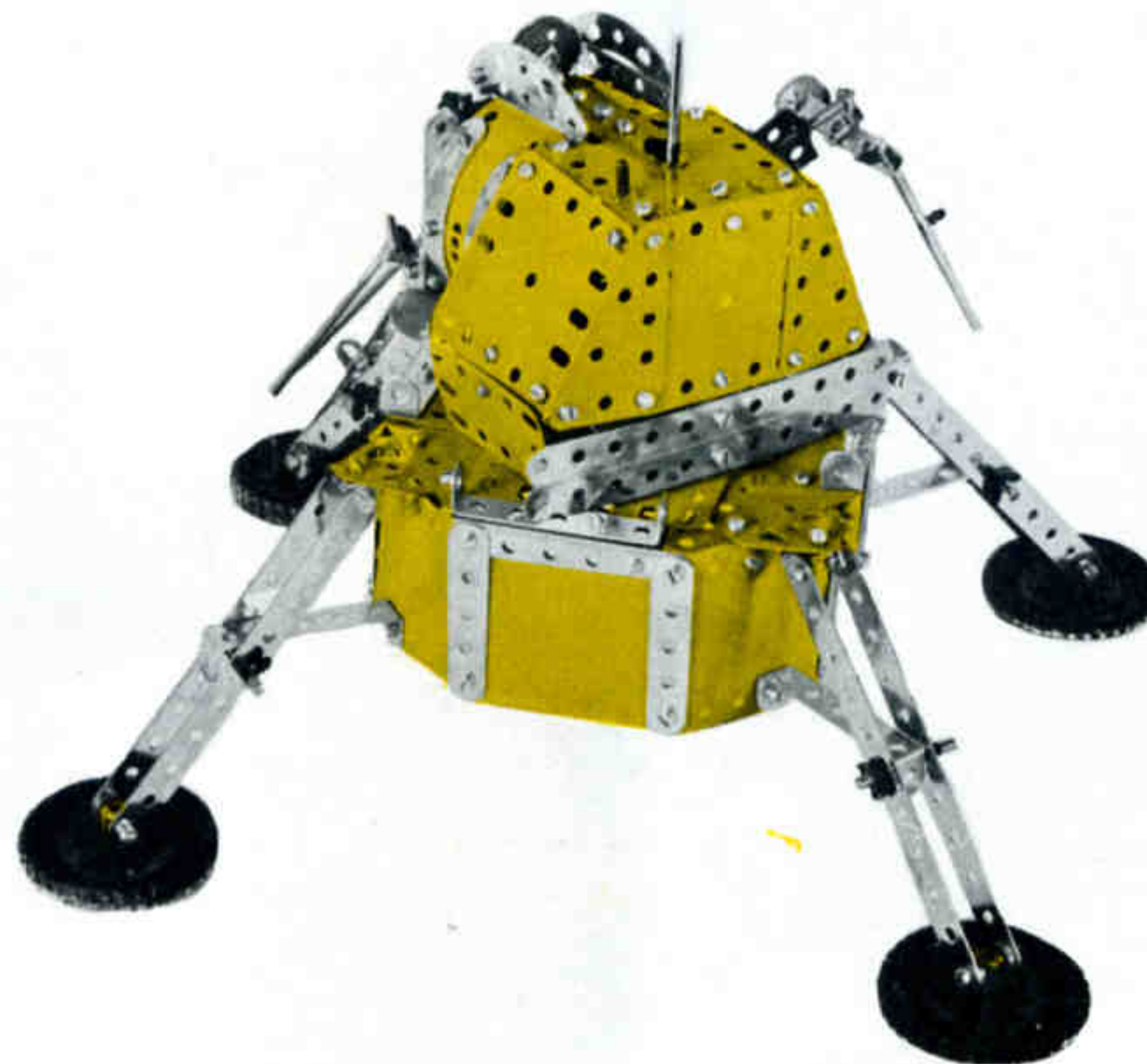



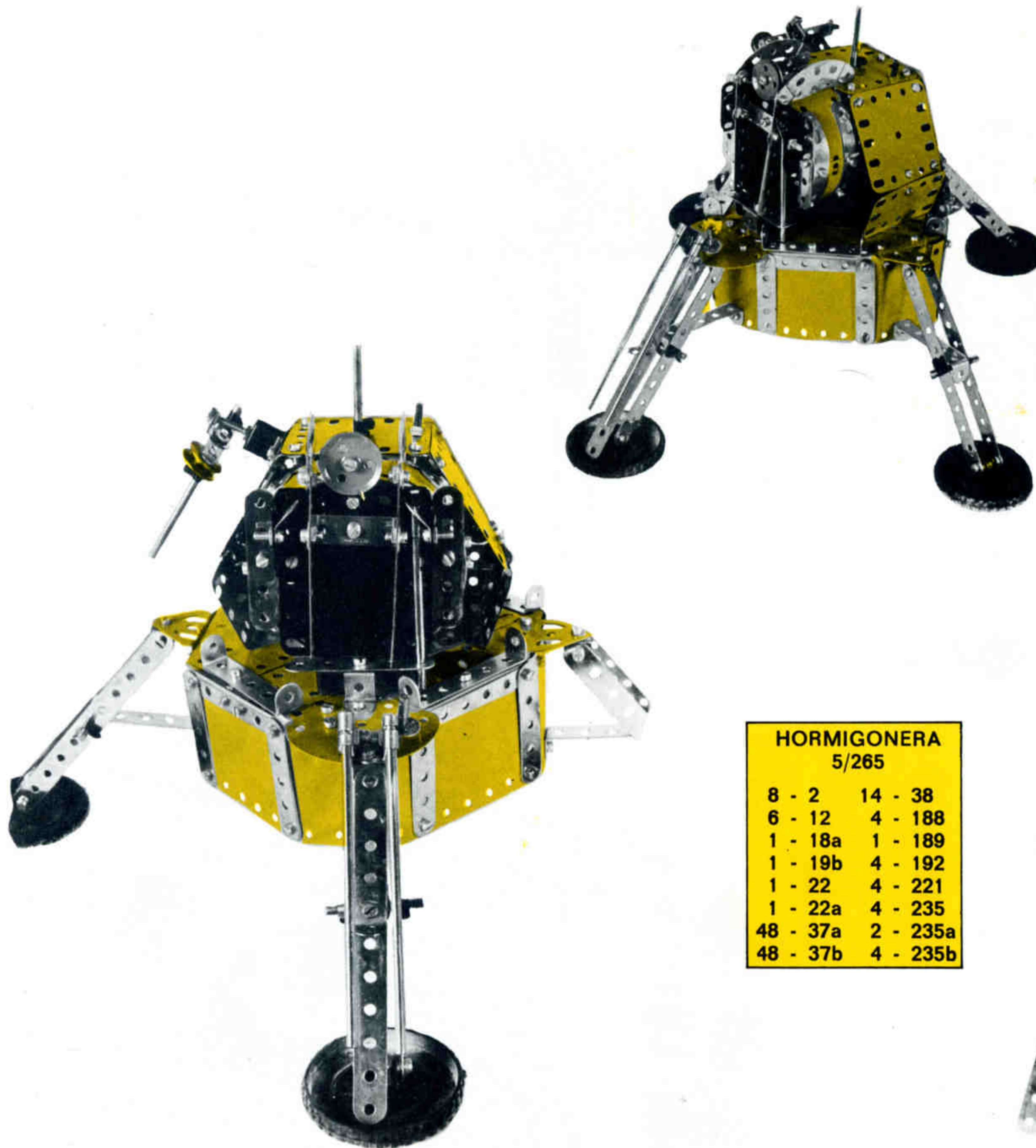

HORMIGONERA	
5/265	
8 - 2	14 - 38
6 - 12	4 - 188
1 - 18a	1 - 189
1 - 19b	4 - 192
1 - 22	4 - 221
1 - 22a	4 - 235
48 - 37a	2 - 235a
48 - 37b	4 - 235b



GRUA DE CONSTRUCCION 5/266			
10 - 1	1 - 18b	1 - 40	1 - 115
14 - 2	2 - 19b	1 - 48	2 - 126a
8 - 5	1 - 20a	8 - 48a	1 - 147b
2 - 6a	1 - 19g	1 - 51	1 - 186
4 - 8	5 - 22	1 - 52	2 - 190
3 - 10	2 - 22a	2 - 53a	2 - 191
2 - 11	1 - 23	2 - 54	4 - 192
1 - 11a	2 - 24	1 - 57c	1 - 213
6 - 12	3 - 35	2 - 80c	2 - 215
2 - 12a	1 - 26	2 - 90a	2 - 235b
1 - 15	81 - 37a	2 - 99	
1 - 15a	70 - 37b	1 - 111a	
4 - 18a	17 - 38	6 - 111c	

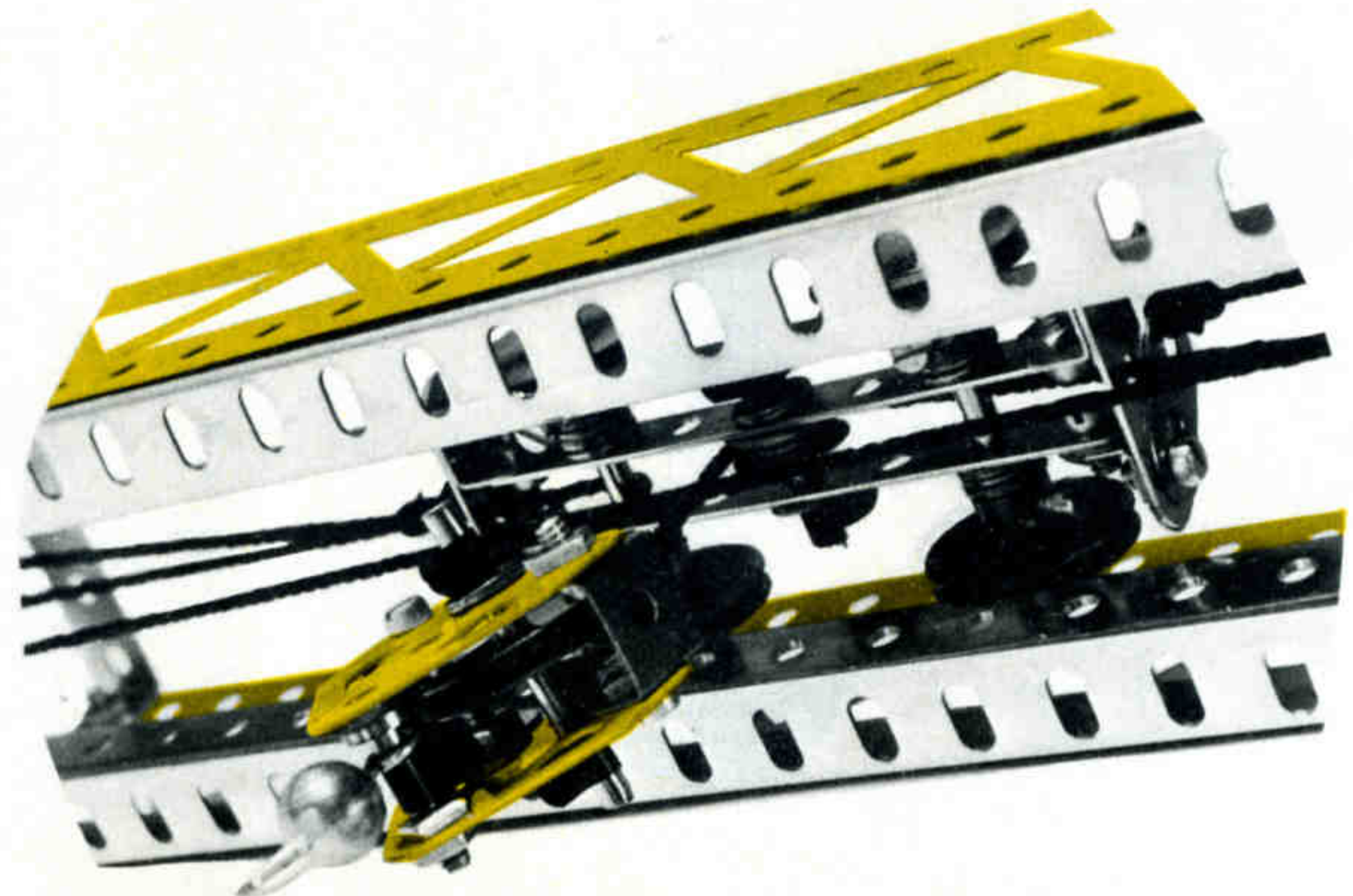
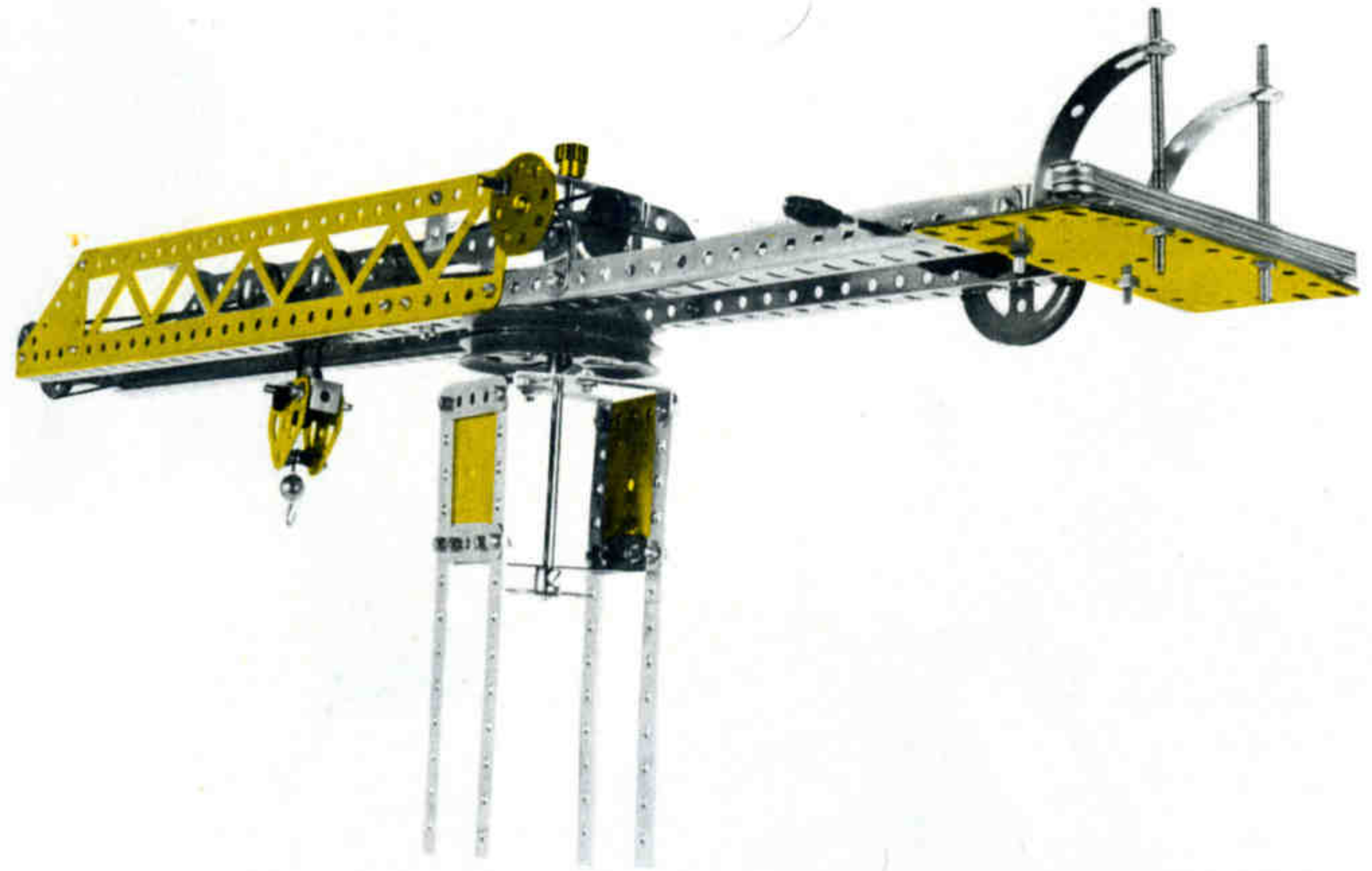

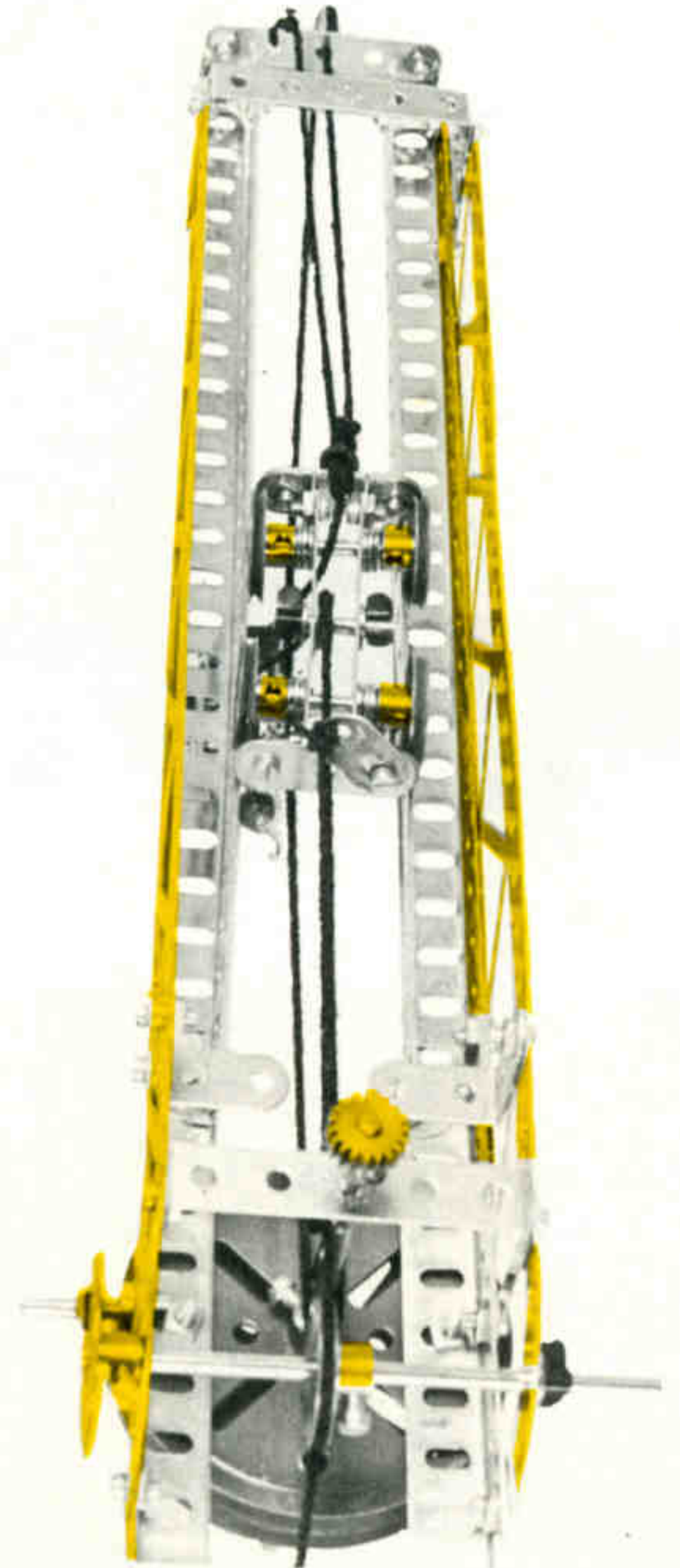
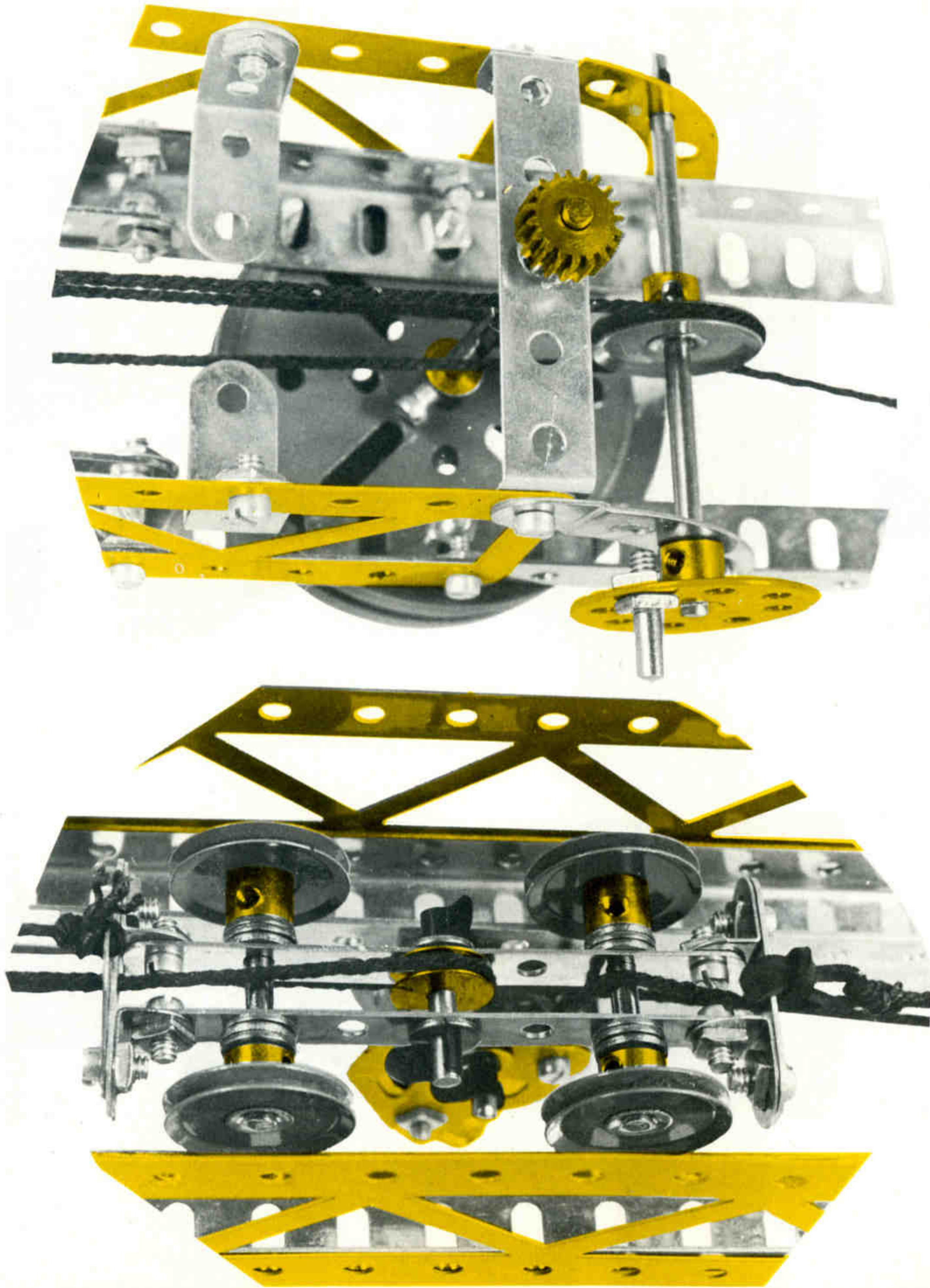

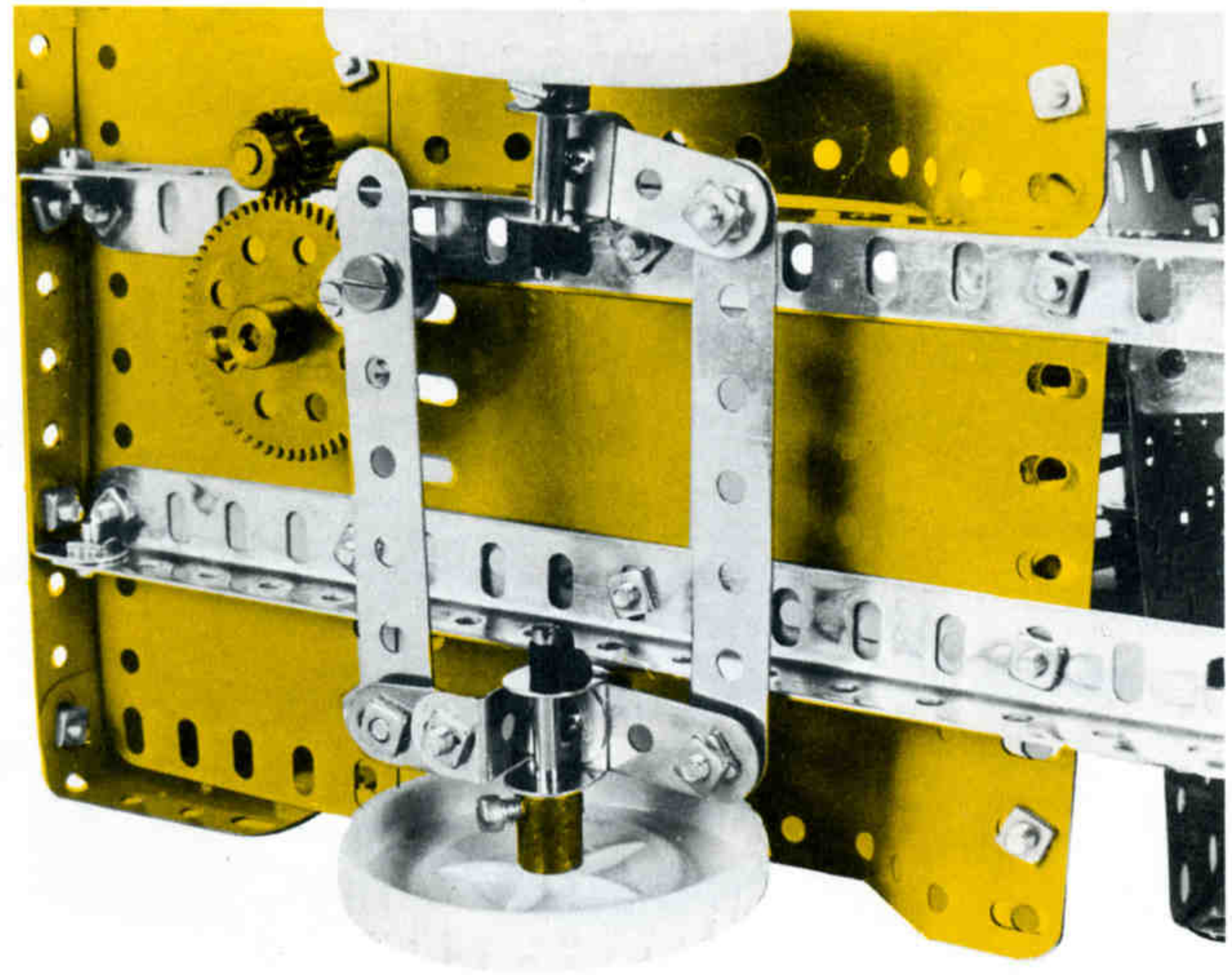
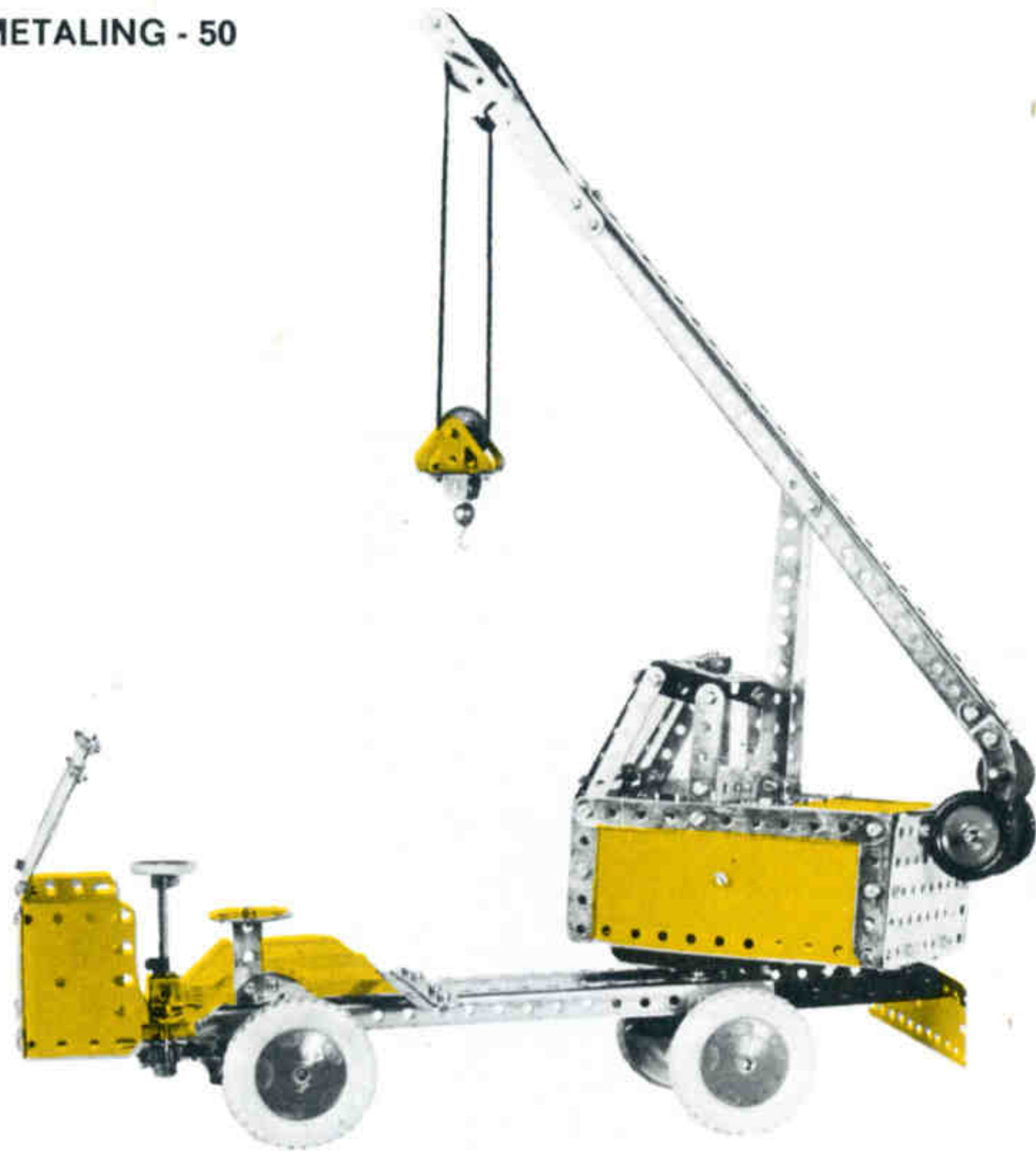

**CAMION GRUA 5/267**

14 - 2	4 - 18a	1 - 48	1 - 147b
2 - 4	1 - 18b	7 - 48a	1 - 155
10 - 5	1 - 19b	1 - 51	1 - 176
2 - 6a	1 - 20a	1 - 52	4 - 187
4 - 8	5 - 22	2 - 53a	3 - 188
5 - 10	1 - 22a	1 - 57c	4 - 189
4 - 11	1 - 24	2 - 90a	2 - 190
10 - 12	1 - 24c	2 - 111a	2 - 191
2 - 12a	10 - 35	6 - 111c	4 - 192
3 - 12c	121 - 37a	1 - 115	1 - 193a
1 - 15	110 - 37b	4 - 125	1 - 193e
1 - 15a	17 - 38	2 - 126	1 - 26
2 - 16	1 - 40	2 - 126a	1 - 27a
2 - 17	1 - 45	2 - 142c	

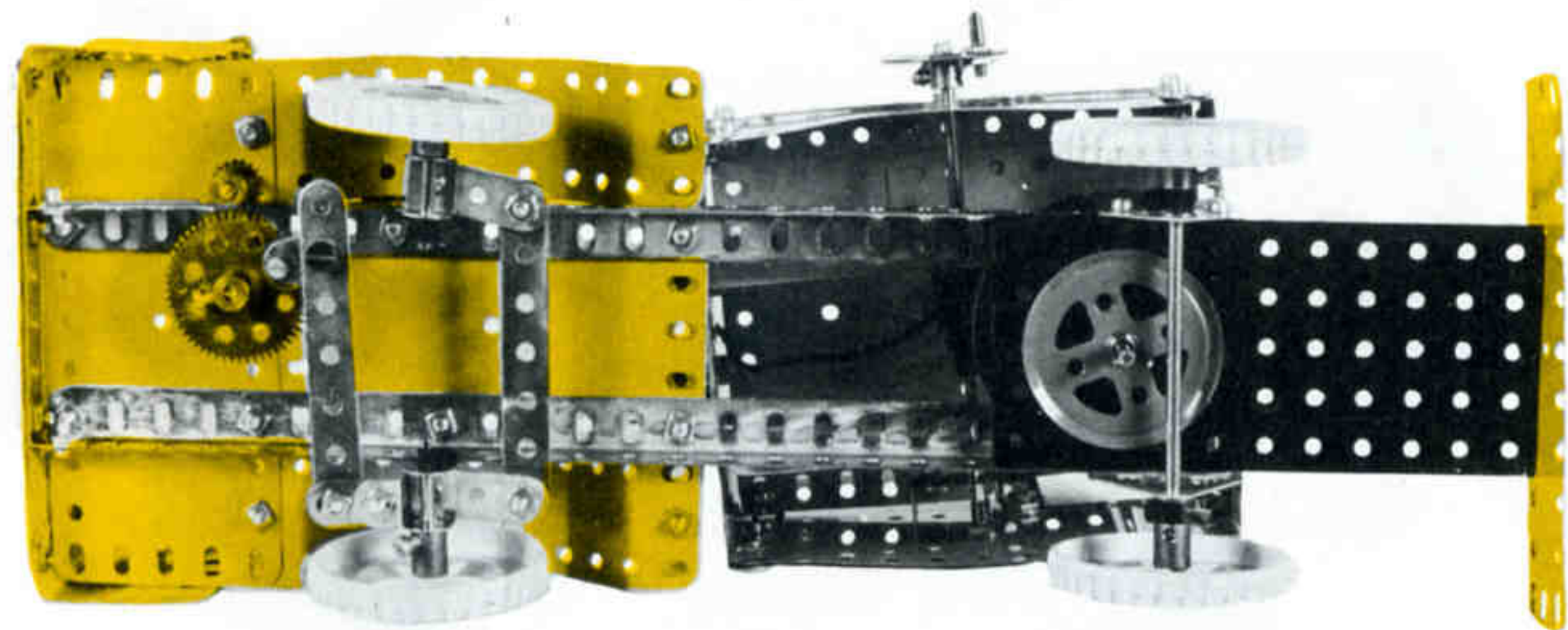

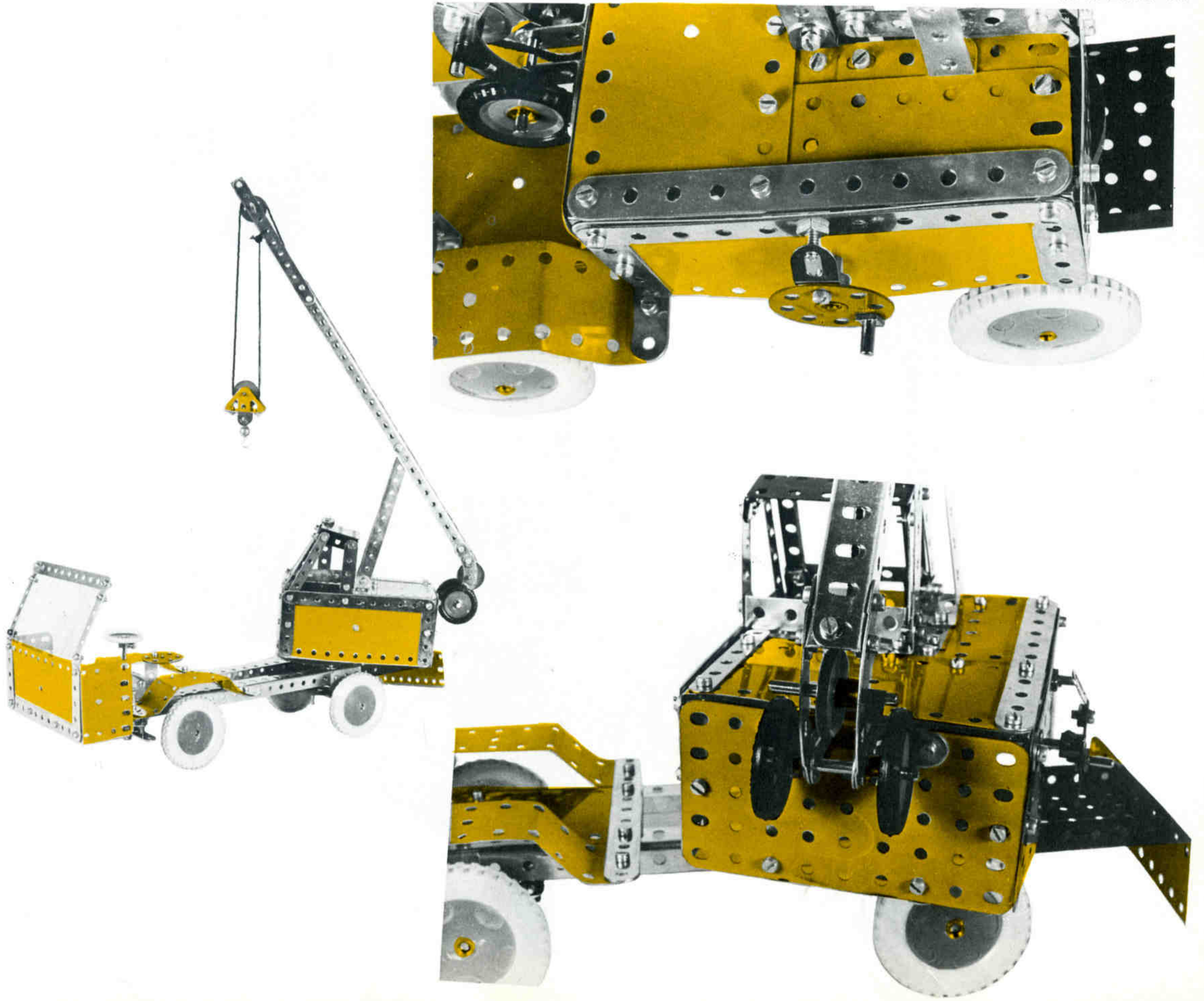

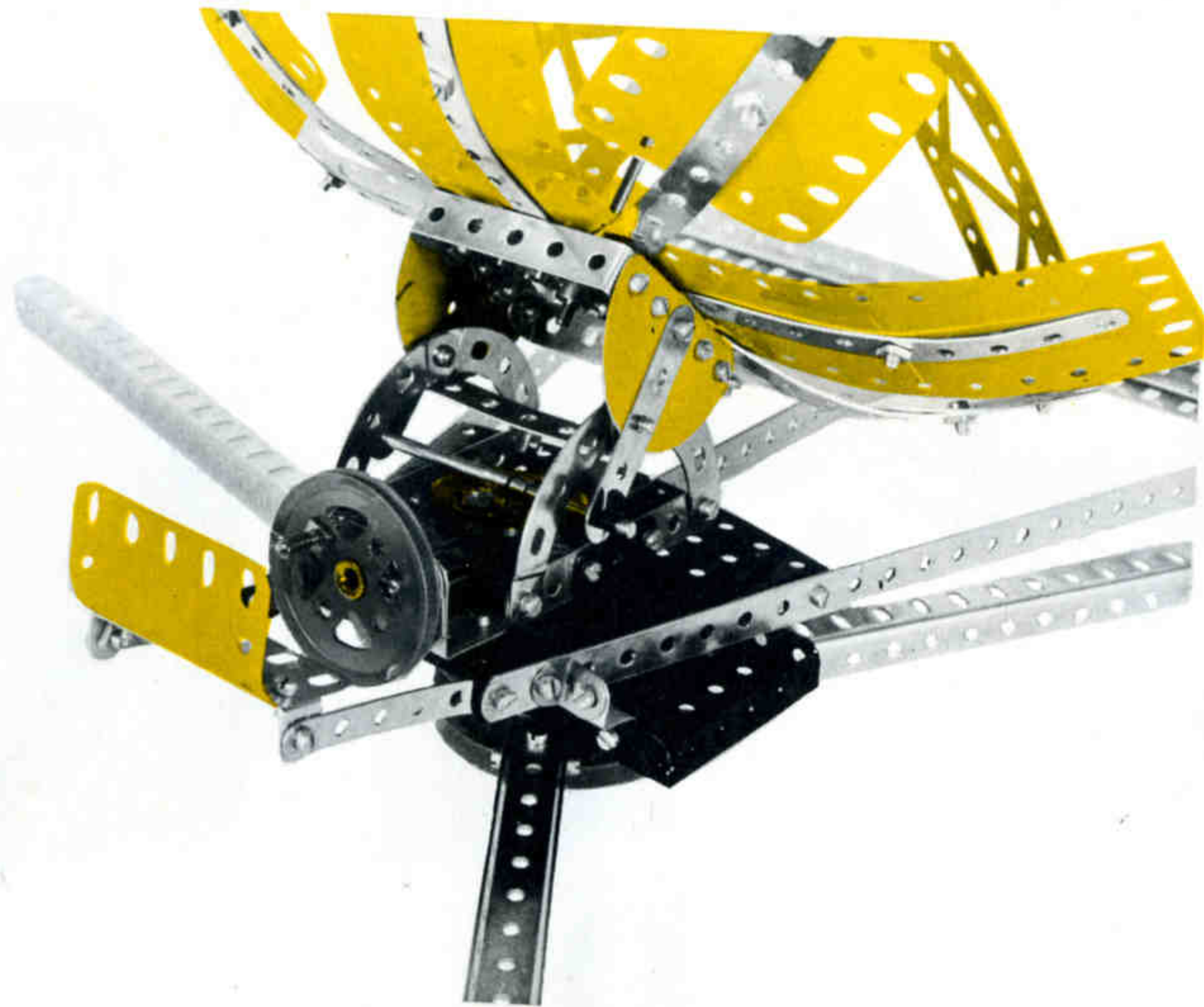
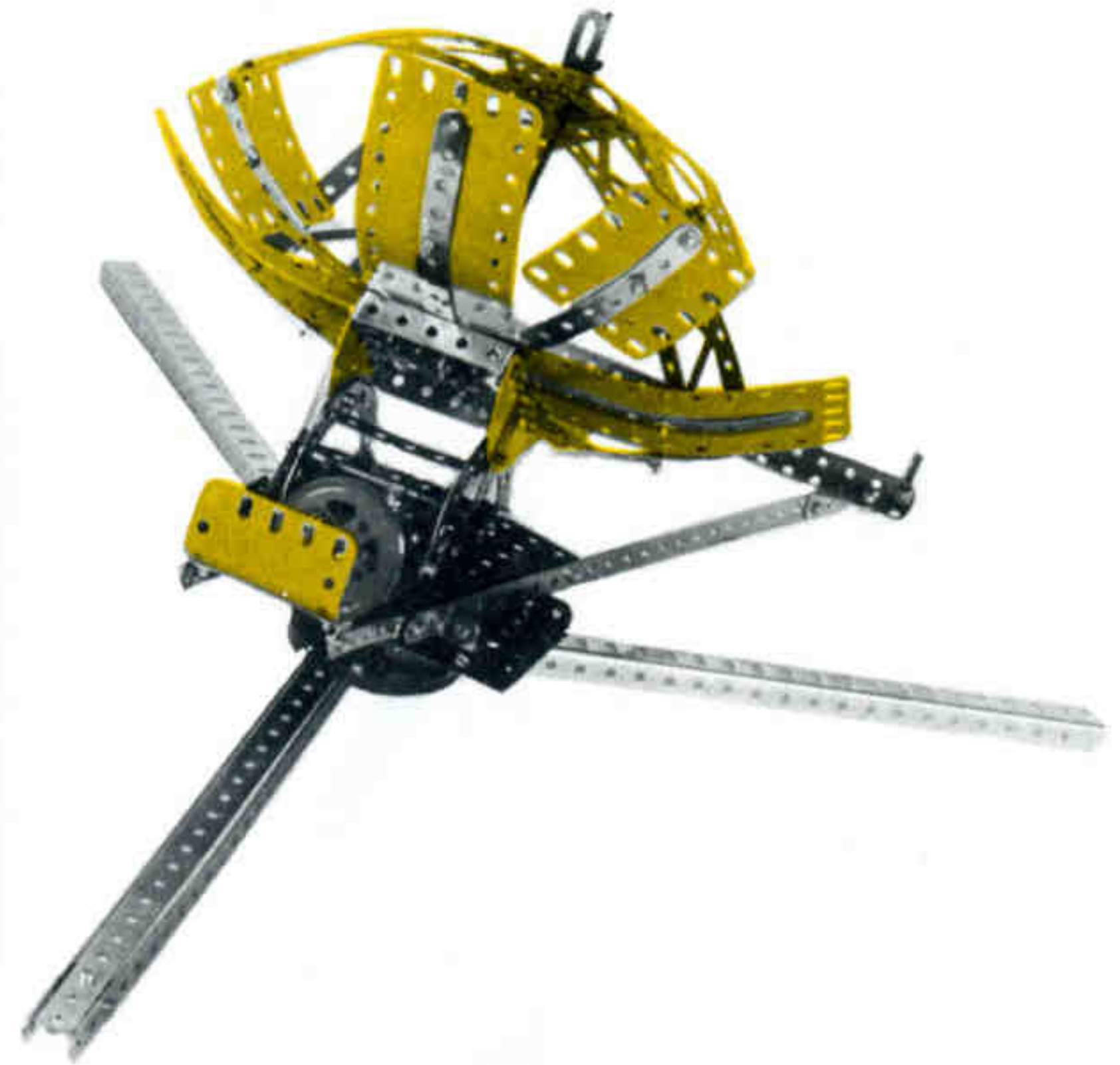
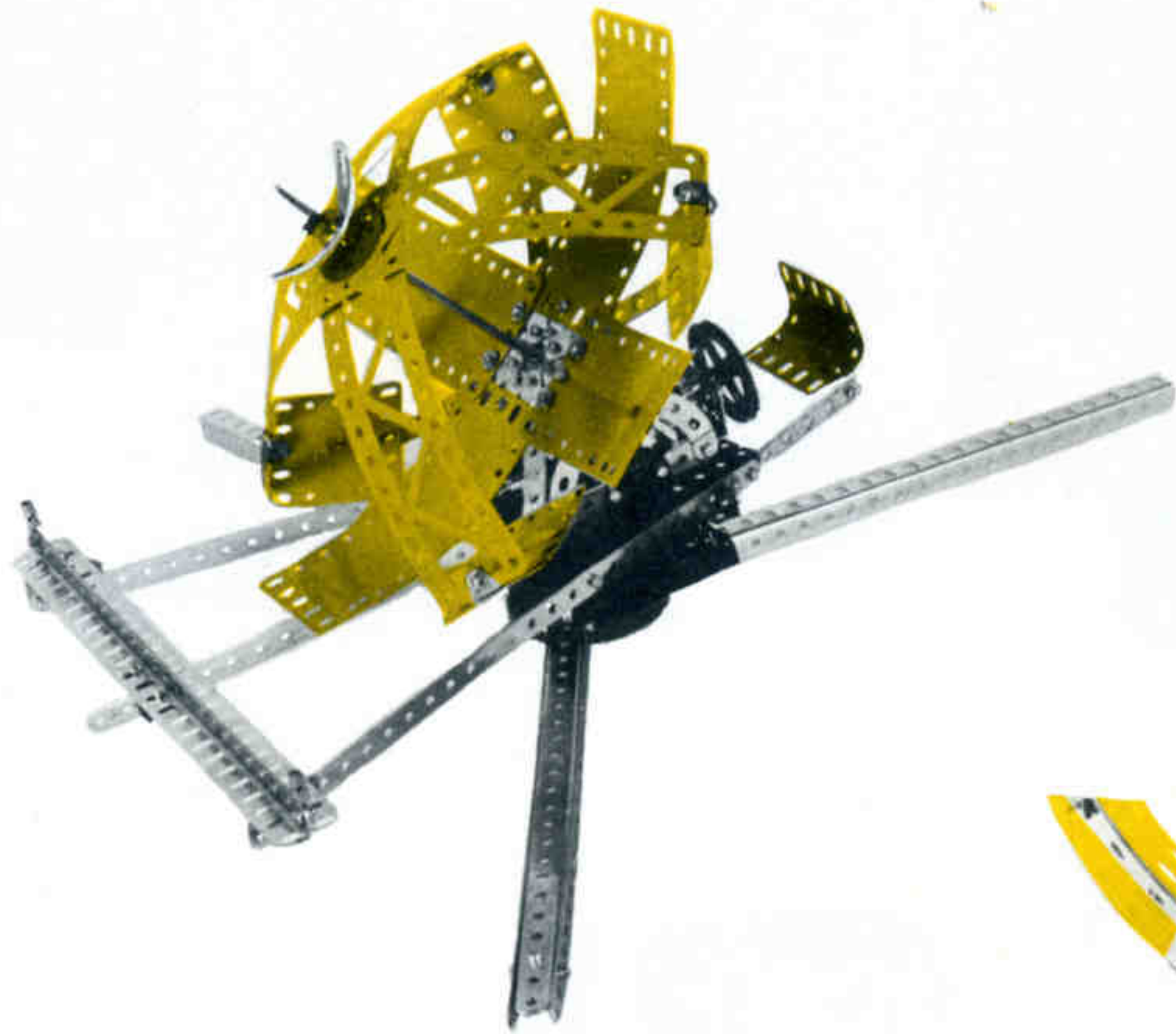

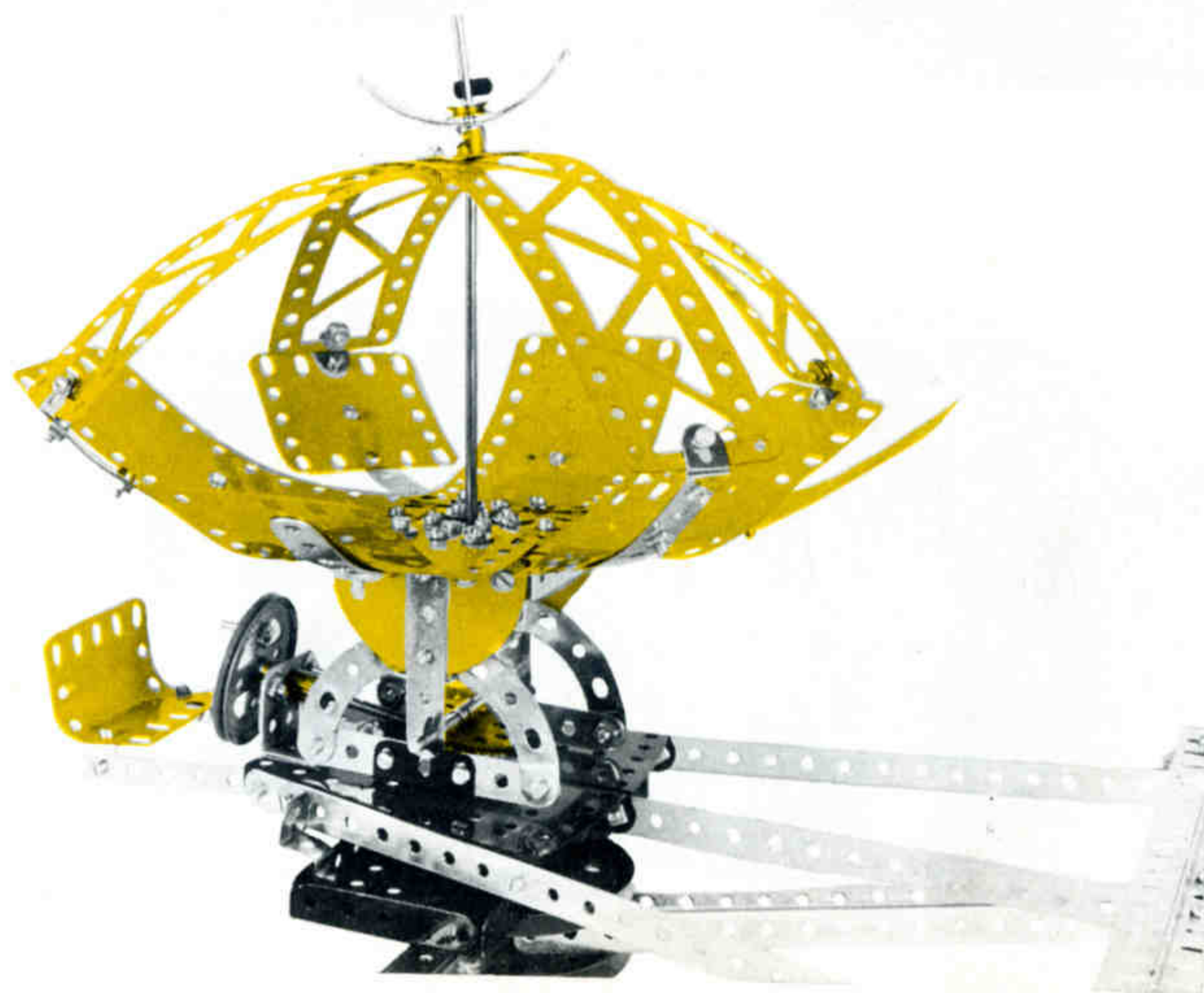
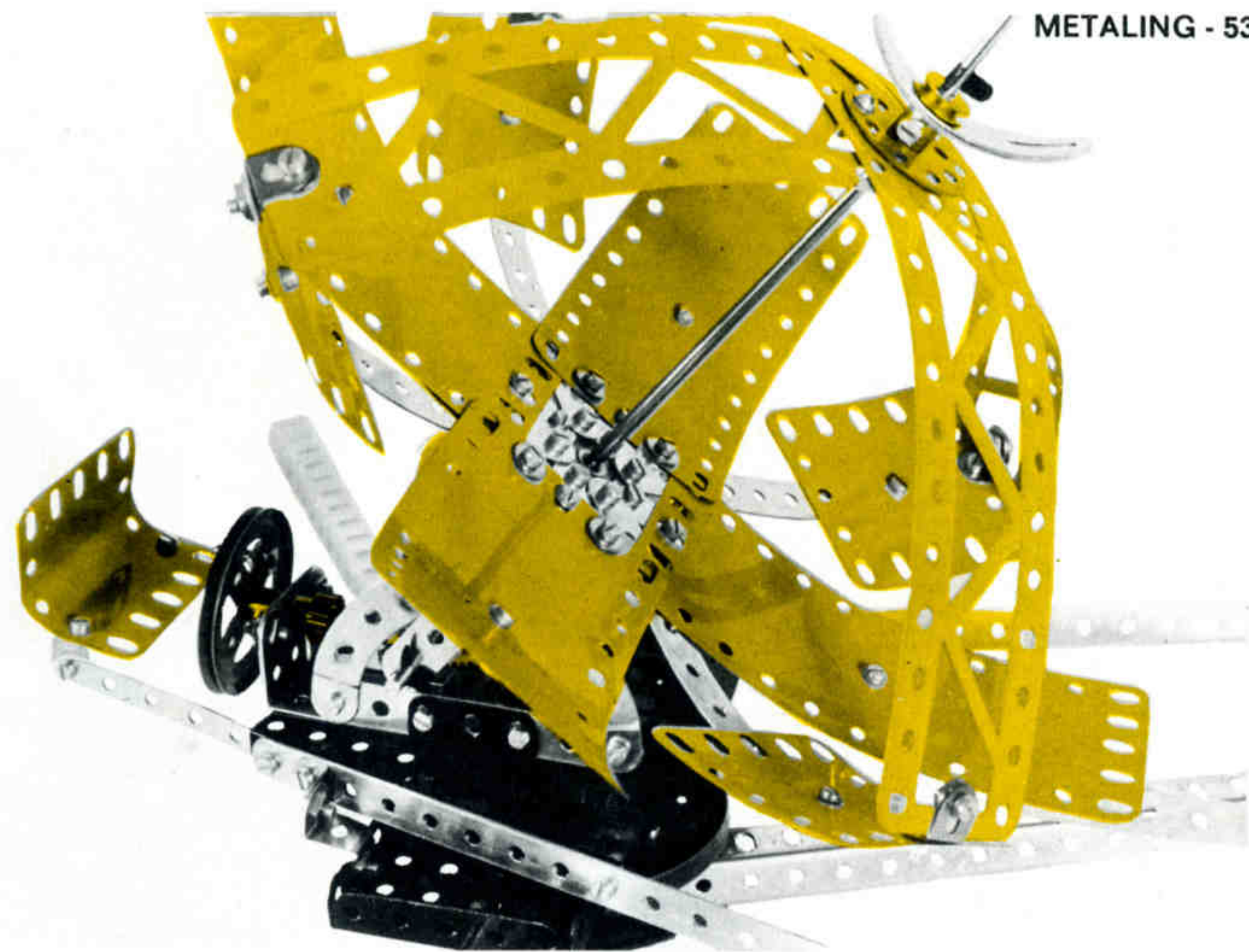

RADAR 5/268		
6 - 1	1 - 27a	2 - 99
4 - 8	1 - 26	1 - 115
4 - 2	3 - 35	2 - 125
2 - 5	128 - 37a	1 - 126a
2 - 11	120 - 37b	4 - 190
2 - 3	4 - 38	4 - 192
6 - 12	1 - 45	1 - 199
2 - 12a	4 - 48a	2 - 214
2 - 19b	1 - 51	2 - 215
1 - 20a	1 - 52	2 - 212
1 - 22	2 - 54	2 - 235a
1 - 23	1 - 80c	
1 - 24	4 - 90a	

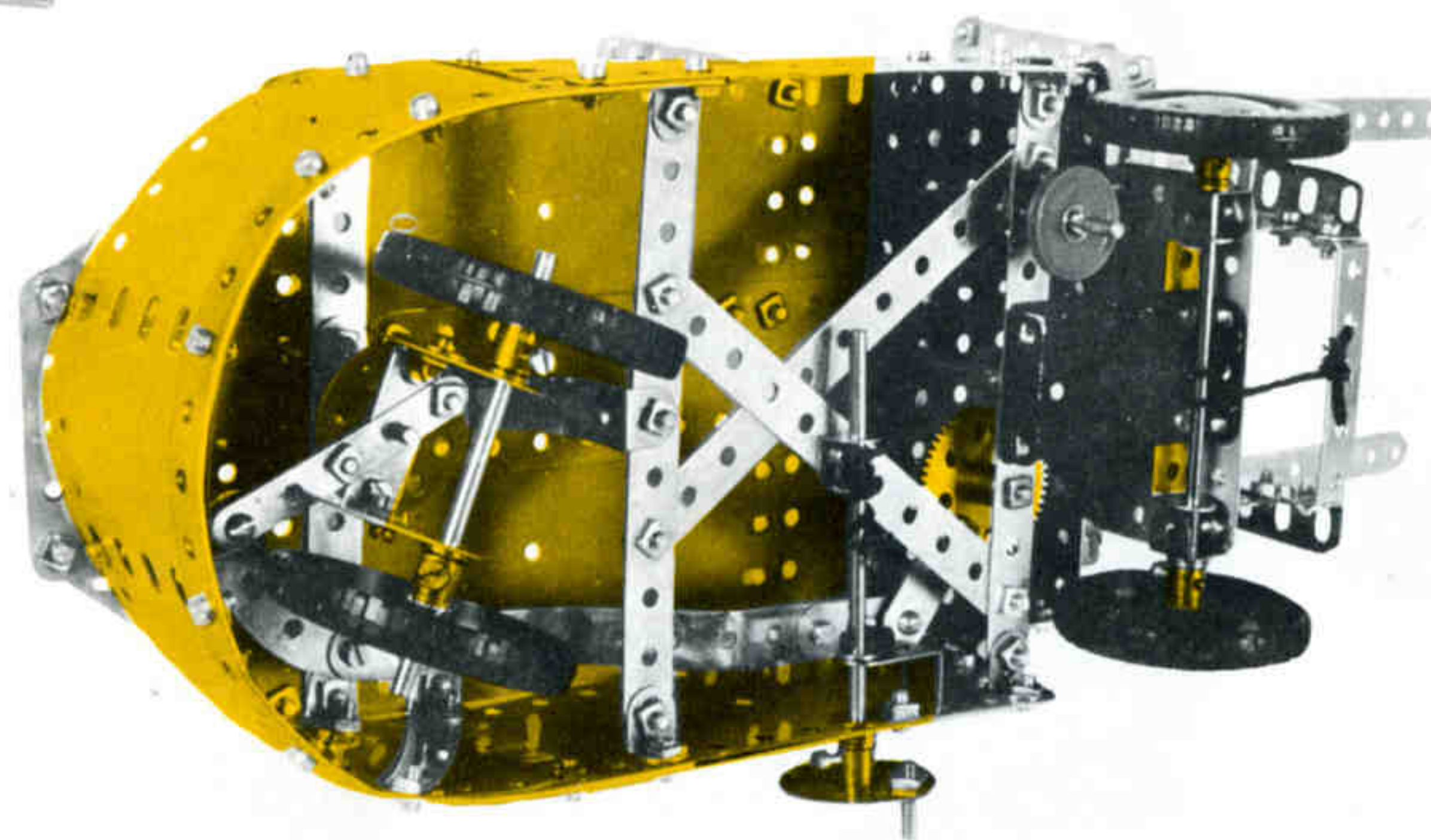
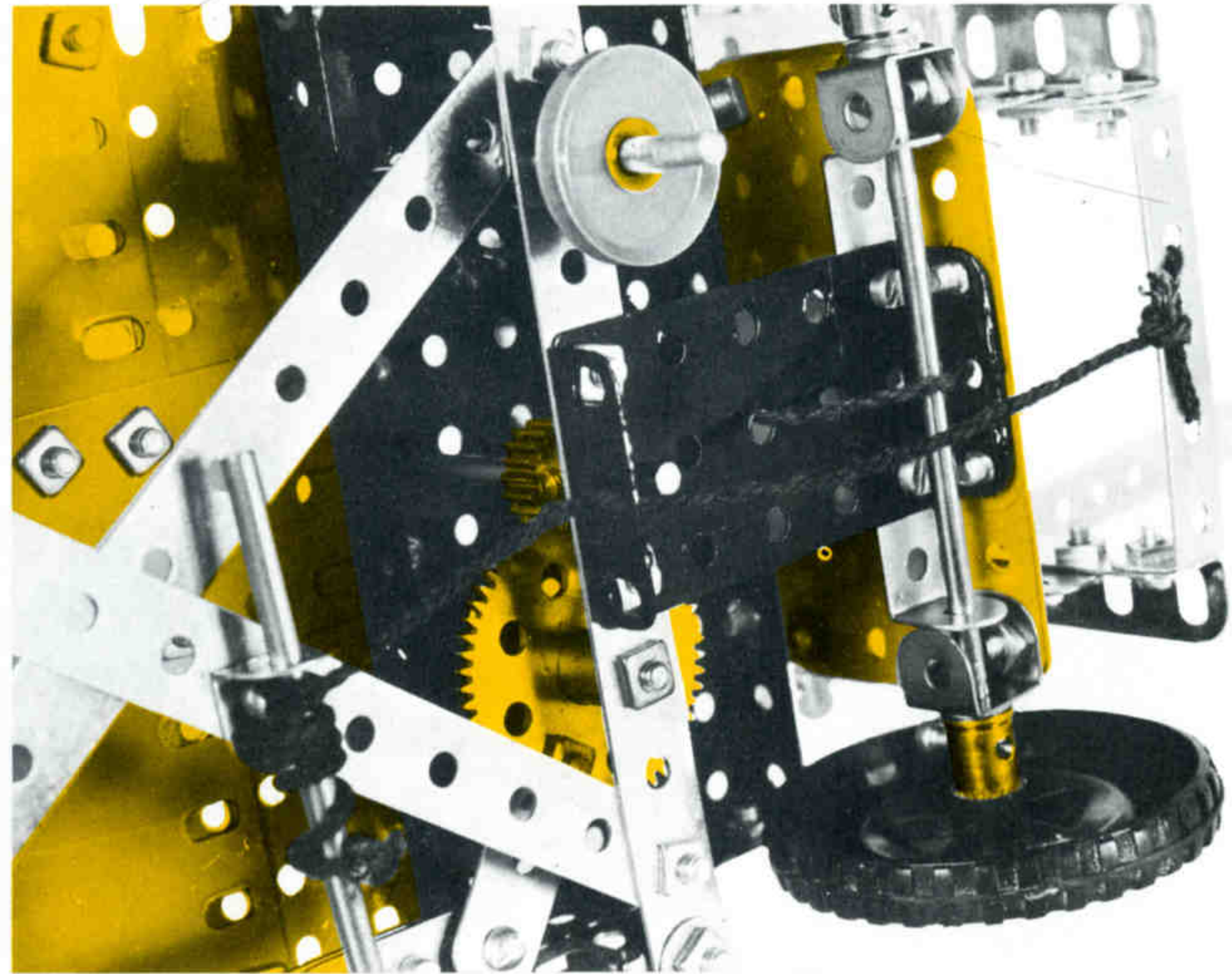
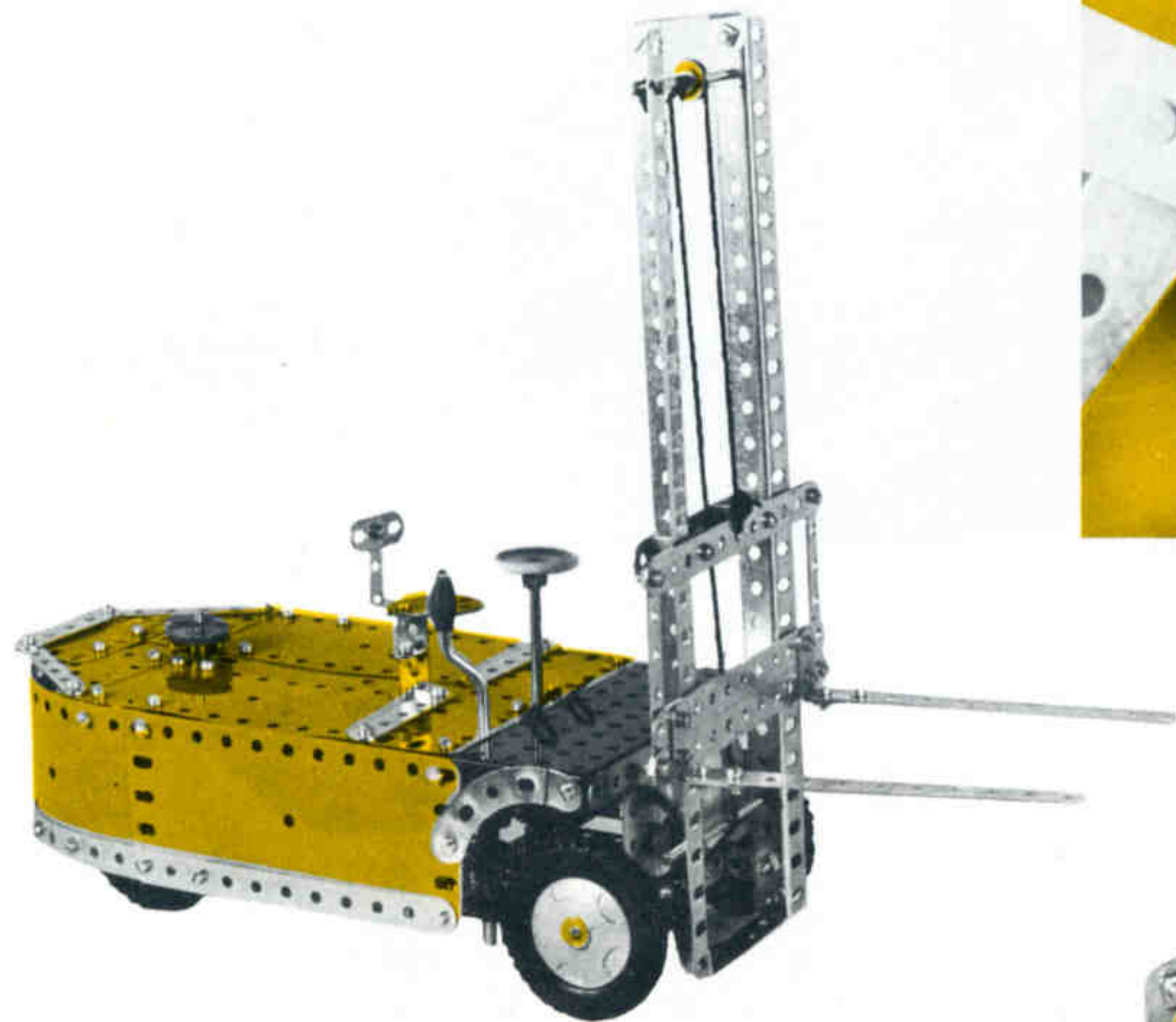



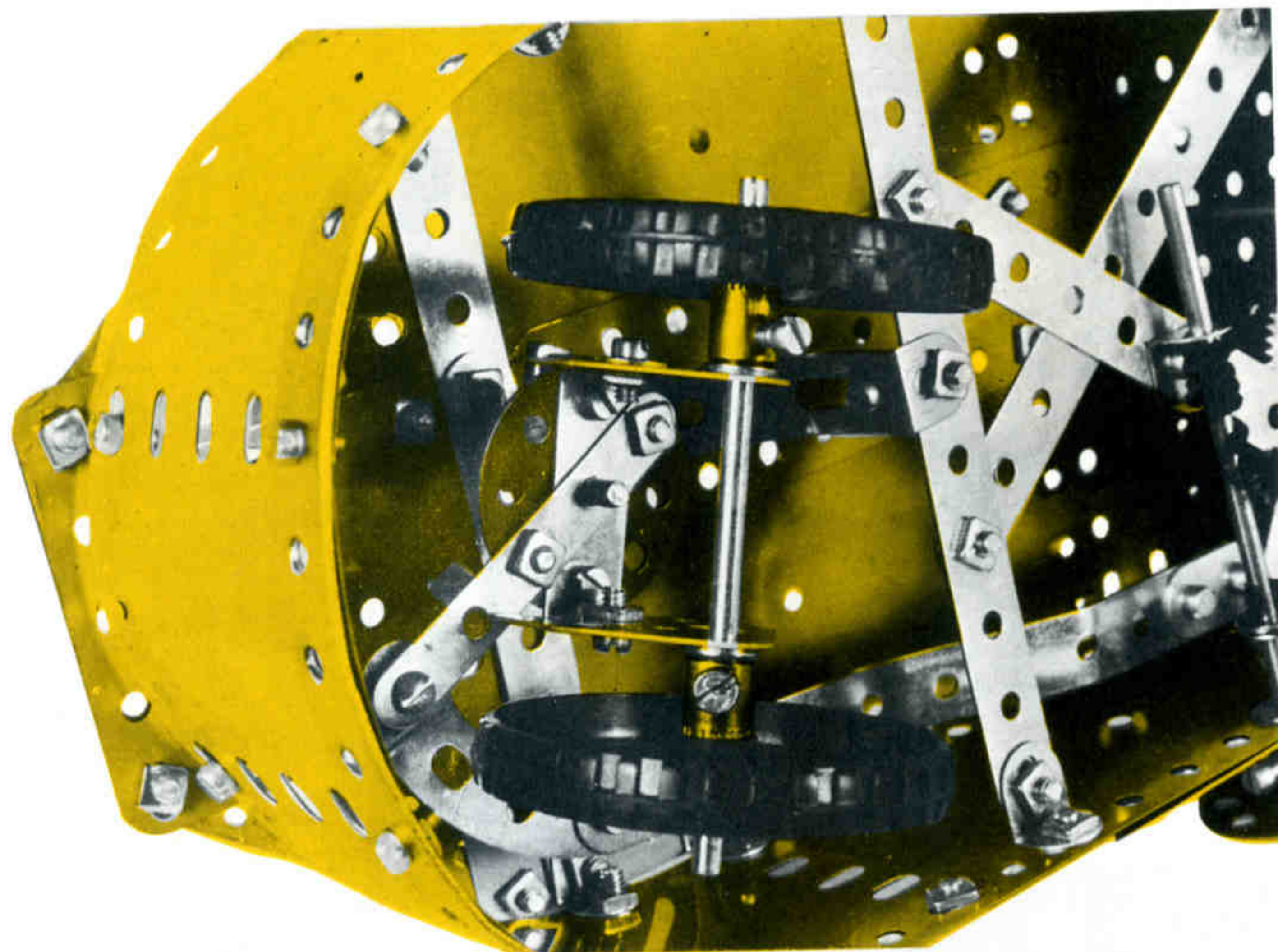

**CARRETILLA ELEVADORA 5/269**

1 - 1	1 - 15a	20 - 38	1 - 147b
14 - 2	1 - 19g	1 - 40	1 - 155
2 - 4	3 - 16	1 - 45	4 - 187
3 - 5	1 - 17	1 - 48	2 - 188
2 - 6a	2 - 22	3 - 48a	2 - 191
2 - 8	1 - 23	1 - 51	4 - 192
4 - 10	1 - 24	1 - 52	1 - 200
4 - 11	1 - 24c	2 - 90a	1 - 215
1 - 11a	1 - 26	4 - 111c	2 - 222
10 - 12	1 - 27a	1 - 115	1 - 235
2 - 12a	5 - 35	4 - 125	2 - 235a
2 - 12c	117 - 37a	2 - 126	
2 - 15	108 - 37b	2 - 126a	

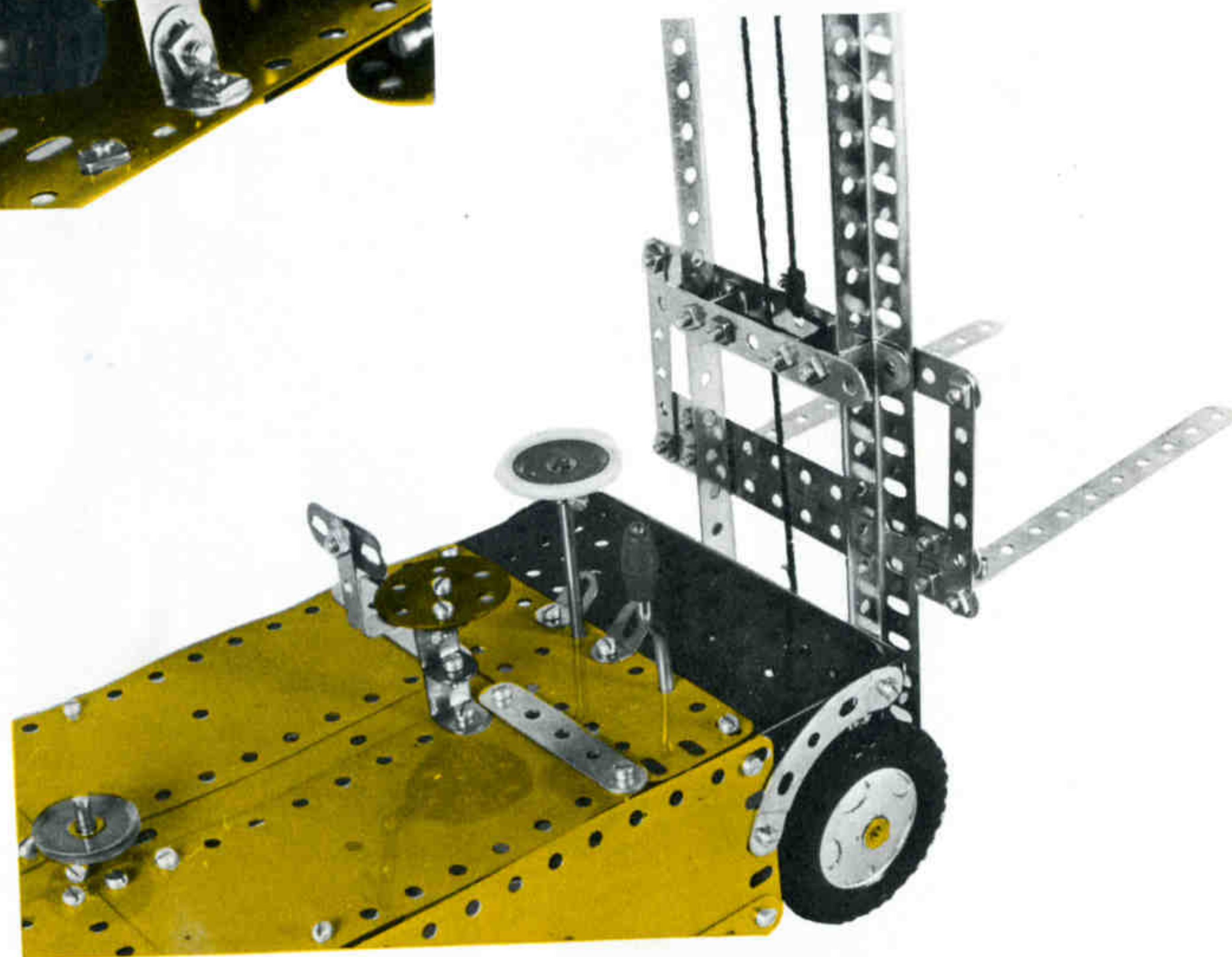

SISMOGRAFO LUNAR 5/270

6 - 1	1 - 19b	1 - 52	2 - 125	1 - 193c
9 - 2	1 - 22	2 - 53a	2 - 126	1 - 194c
4 - 8	1 - 24	2 - 54	2 - 126a	2 - 214
2 - 11	1 - 27a	2 - 80c	138 - 37a	2 - 212a
6 - 12	7 - 35	2 - 90a	125 - 37b	2 - 215
4 - 12c	1 - 40	4 - 99	2 - 187	6 - 235
2 - 16	4 - 48a	1 - 115	4 - 189	4 - 235a

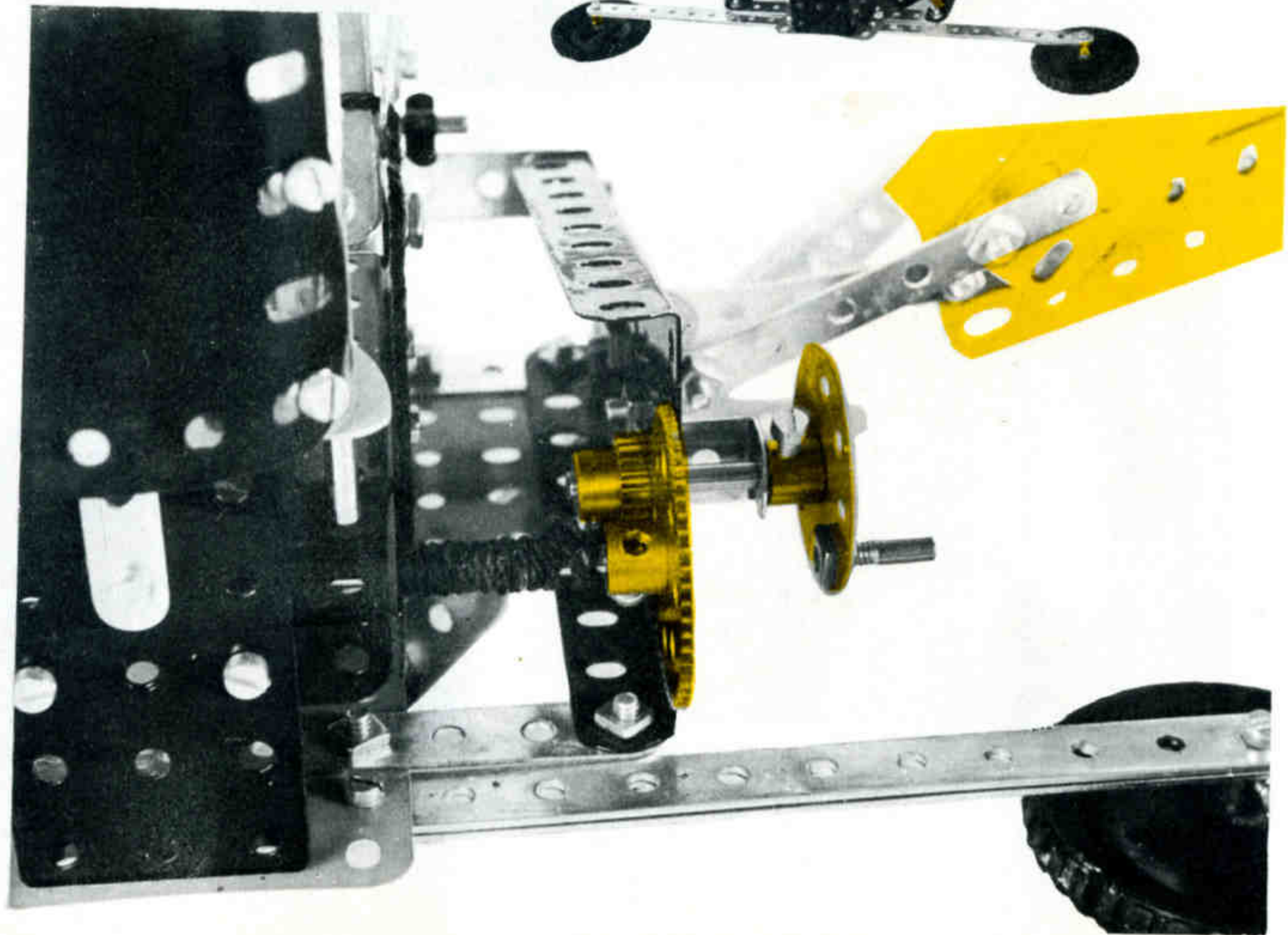
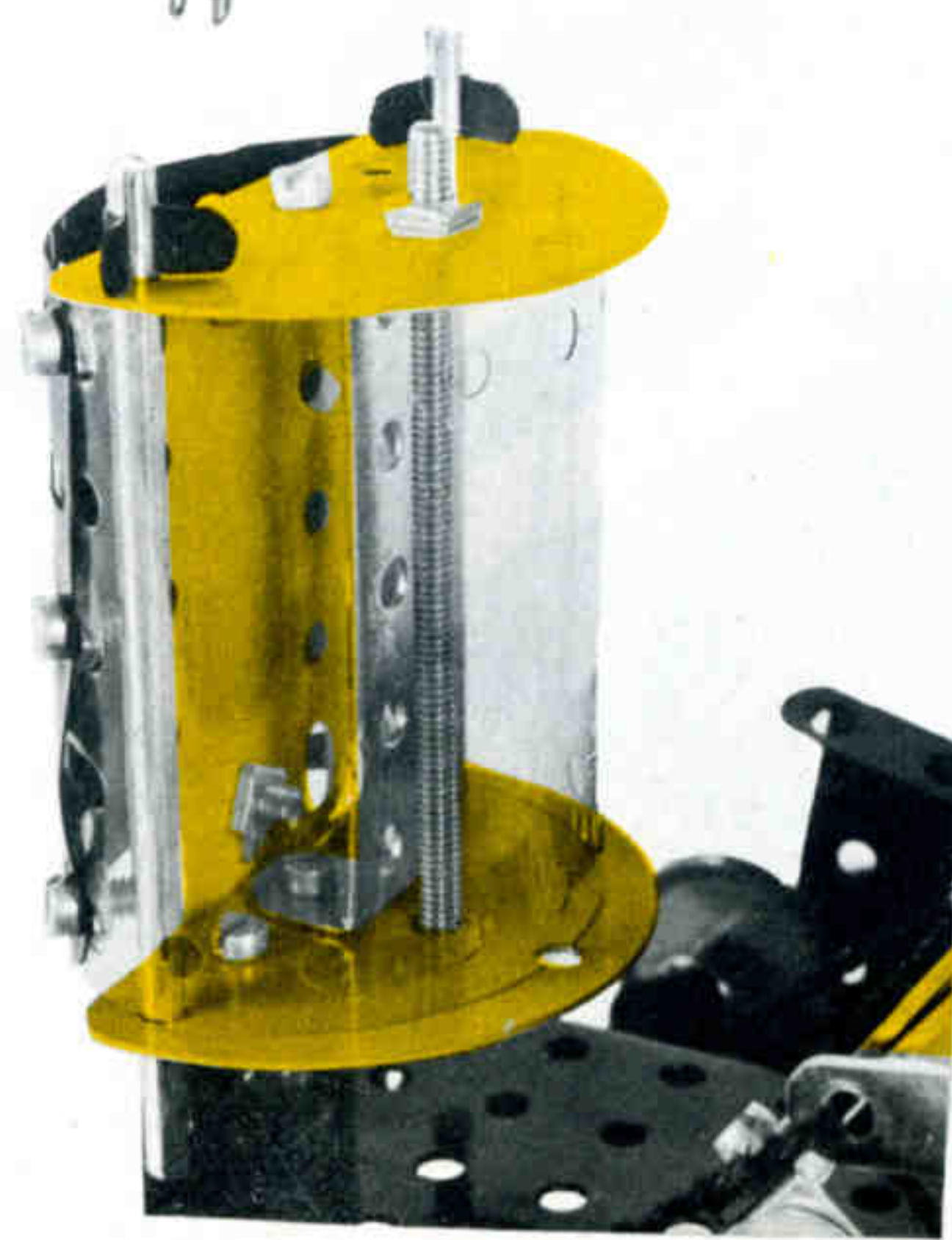
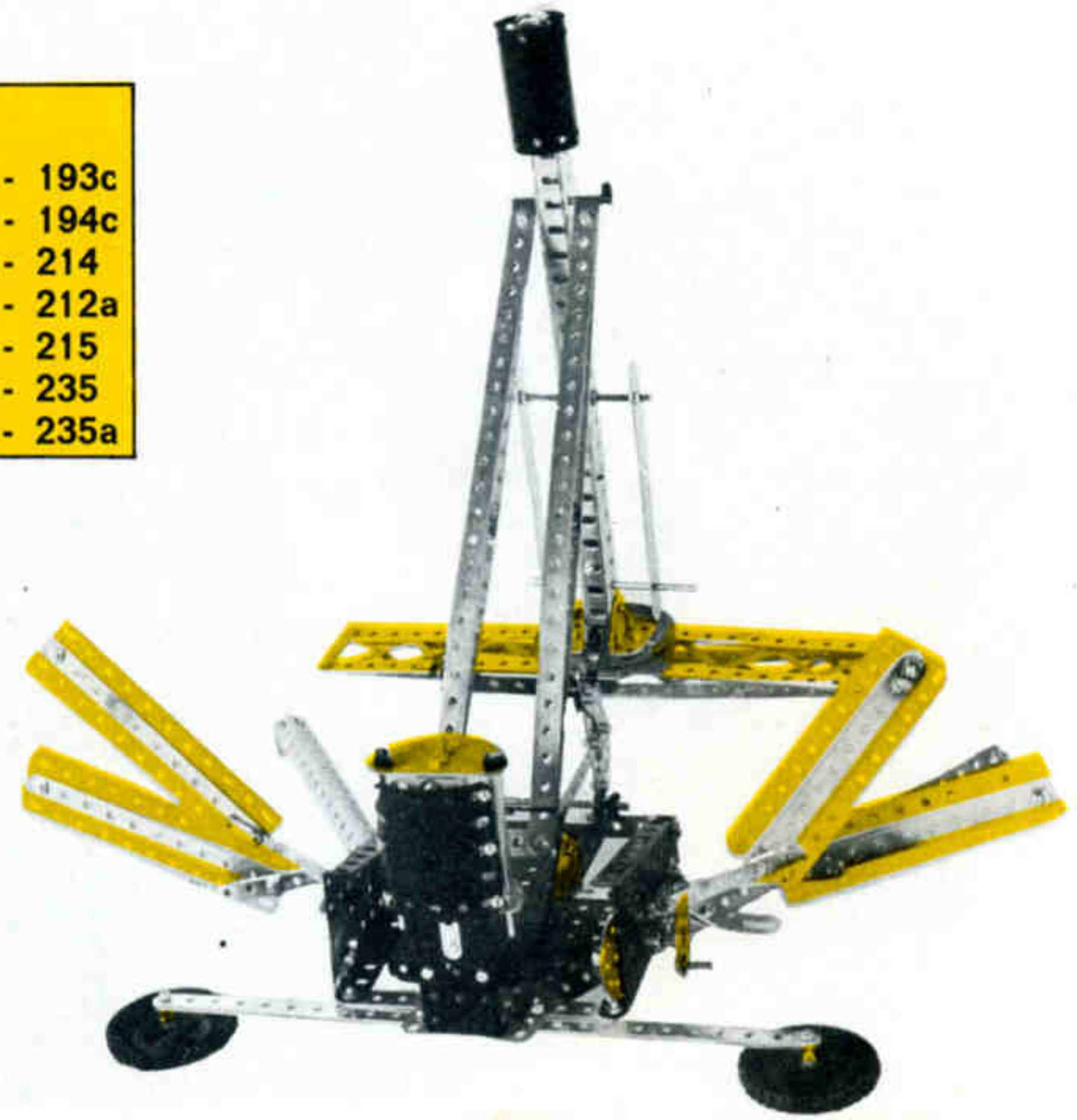
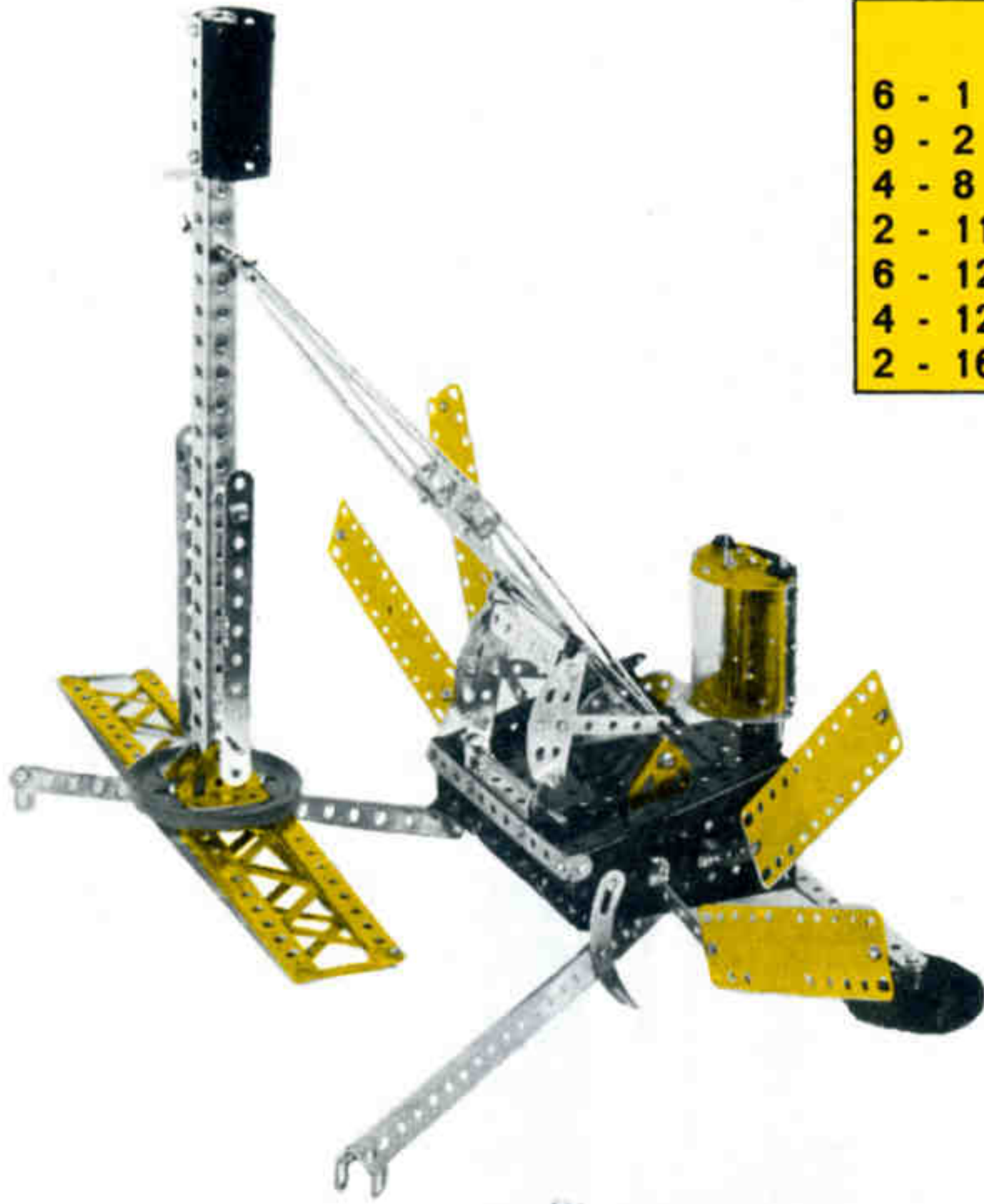



- ROMANA  
6/271**
- 2 - 3
  - 2 - 4
  - 1 - 10
  - 1 - 17
  - 2 - 22
  - 2 - 35
  - 17 - 37a
  - 5 - 37b
  - 4 - 38
  - 1 - 48
  - 2 - 48a
  - 1 - 57c
  - 5 - 111c
  - 1 - 186
  - 2 - 222
  - 2 - 235

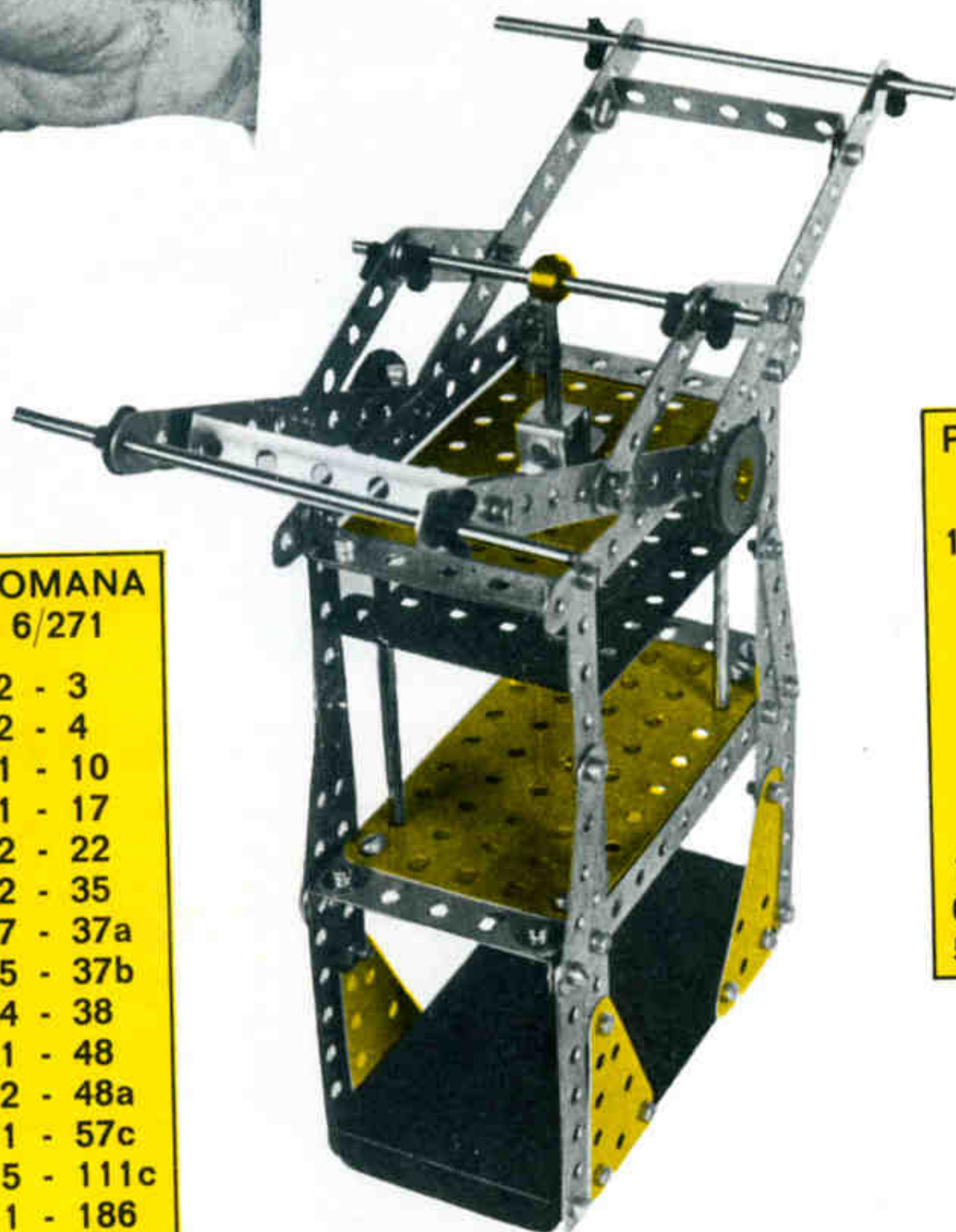

- PRENSA DE BALAS  
DE PAJA 6/272**
- |          |          |
|----------|----------|
| 12 - 2   | 16 - 38  |
| 4 - 3    | 1 - 45   |
| 8 - 5    | 6 - 48a  |
| 2 - 15   | 1 - 52   |
| 1 - 15b  | 1 - 53   |
| 4 - 16   | 2 - 53a  |
| 2 - 22   | 1 - 59   |
| 1 - 24   | 1 - 80c  |
| 12 - 35  | 2 - 111c |
| 62 - 37a | 1 - 192  |
| 56 - 37b | 4 - 221  |

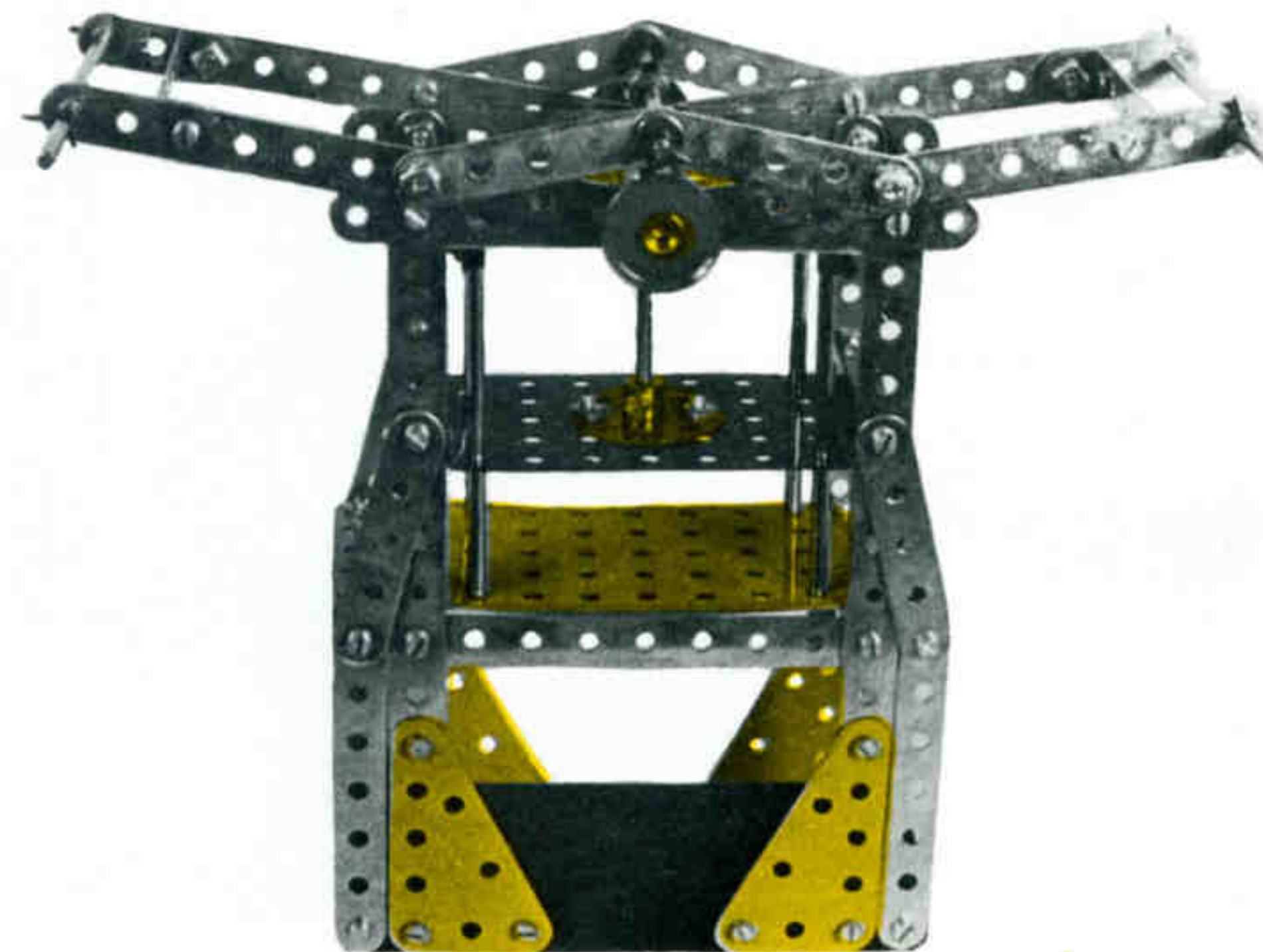
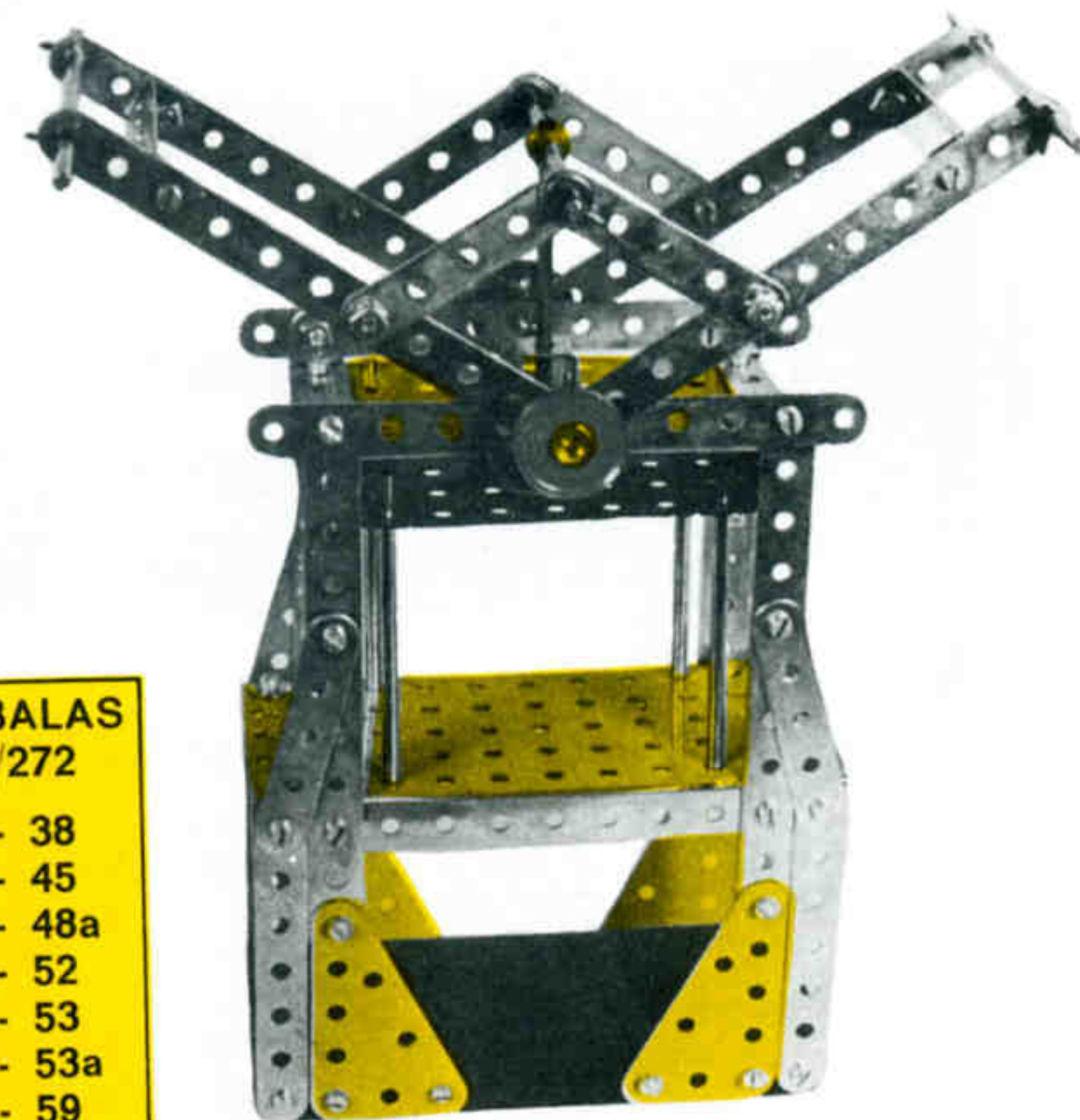

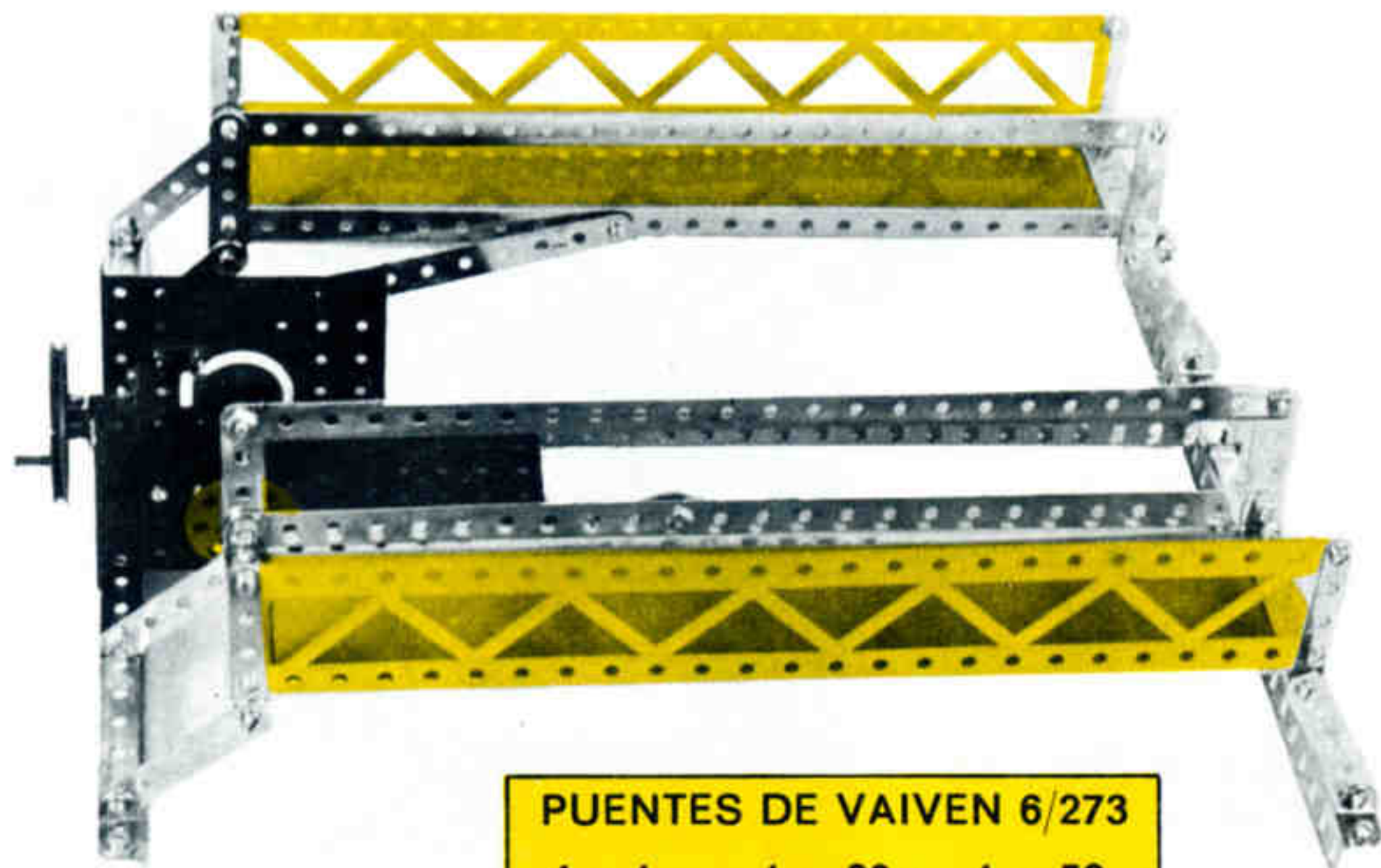

**PUENTES DE VAIVEN 6/273**

4 - 1	1 - 20a	1 - 52
2 - 2	2 - 22	2 - 53
13 - 5	2 - 24	2 - 59
4 - 8	92 - 37a	2 - 99
12 - 12	72 - 37b	1 - 115
2 - 12a	14 - 38	2 - 155
1 - 15a	1 - 45	2 - 197
1 - 18a	4 - 48a	

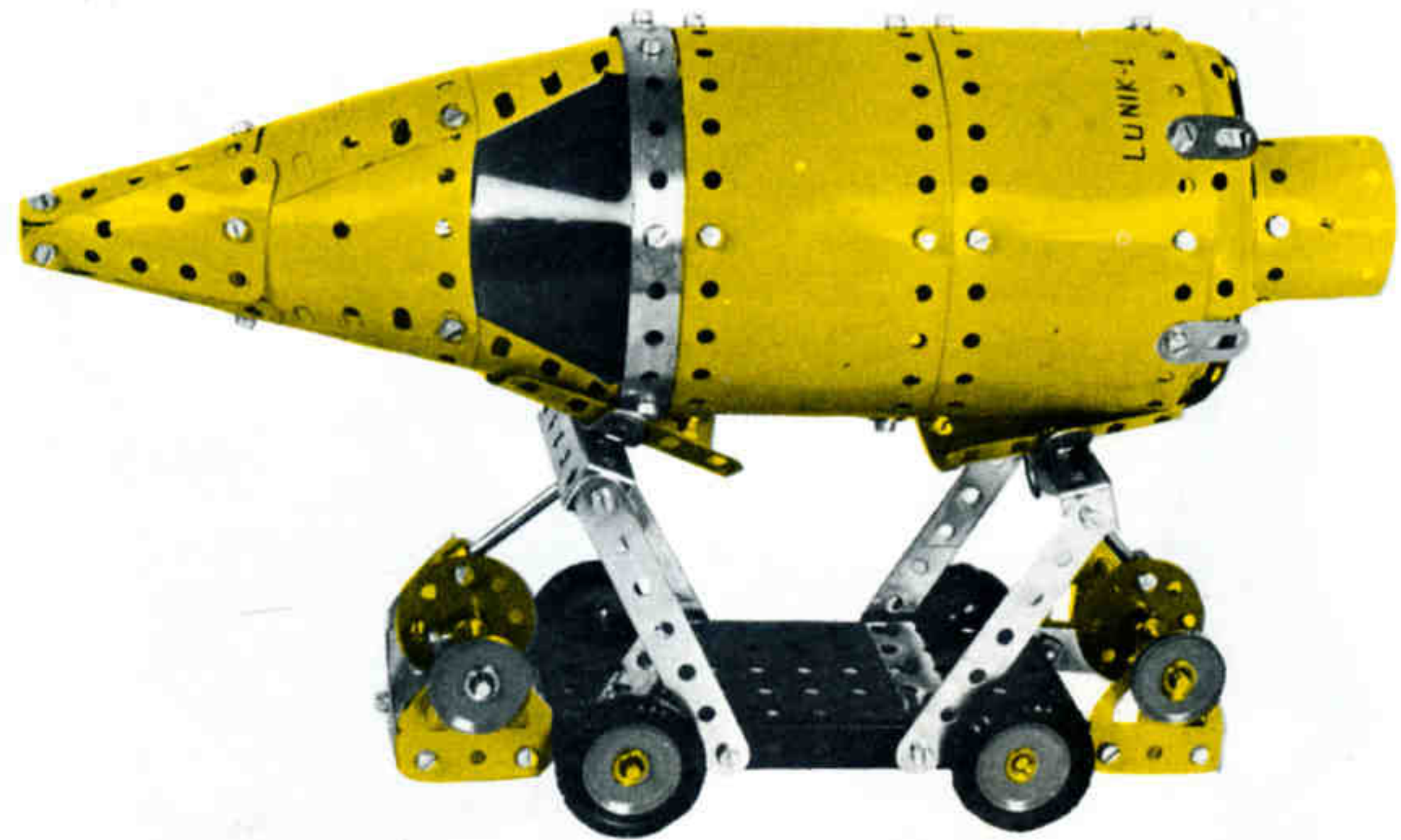

**LUNIK - 1 6/274**

1 - 1	4 - 16	8 - 38	4 - 188
4 - 2	2 - 17	1 - 48	3 - 189
4 - 3	5 - 22	6 - 48a	6 - 190
4 - 5	1 - 22a	1 - 52	2 - 191
2 - 3	2 - 24	2 - 59	1 - 193c
6 - 10	4 - 35	2 - 111c	2 - 197
2 - 11	82 - 37a	4 - 126a	2 - 215
8 - 12	75 - 37b	4 - 142c	4 - 221

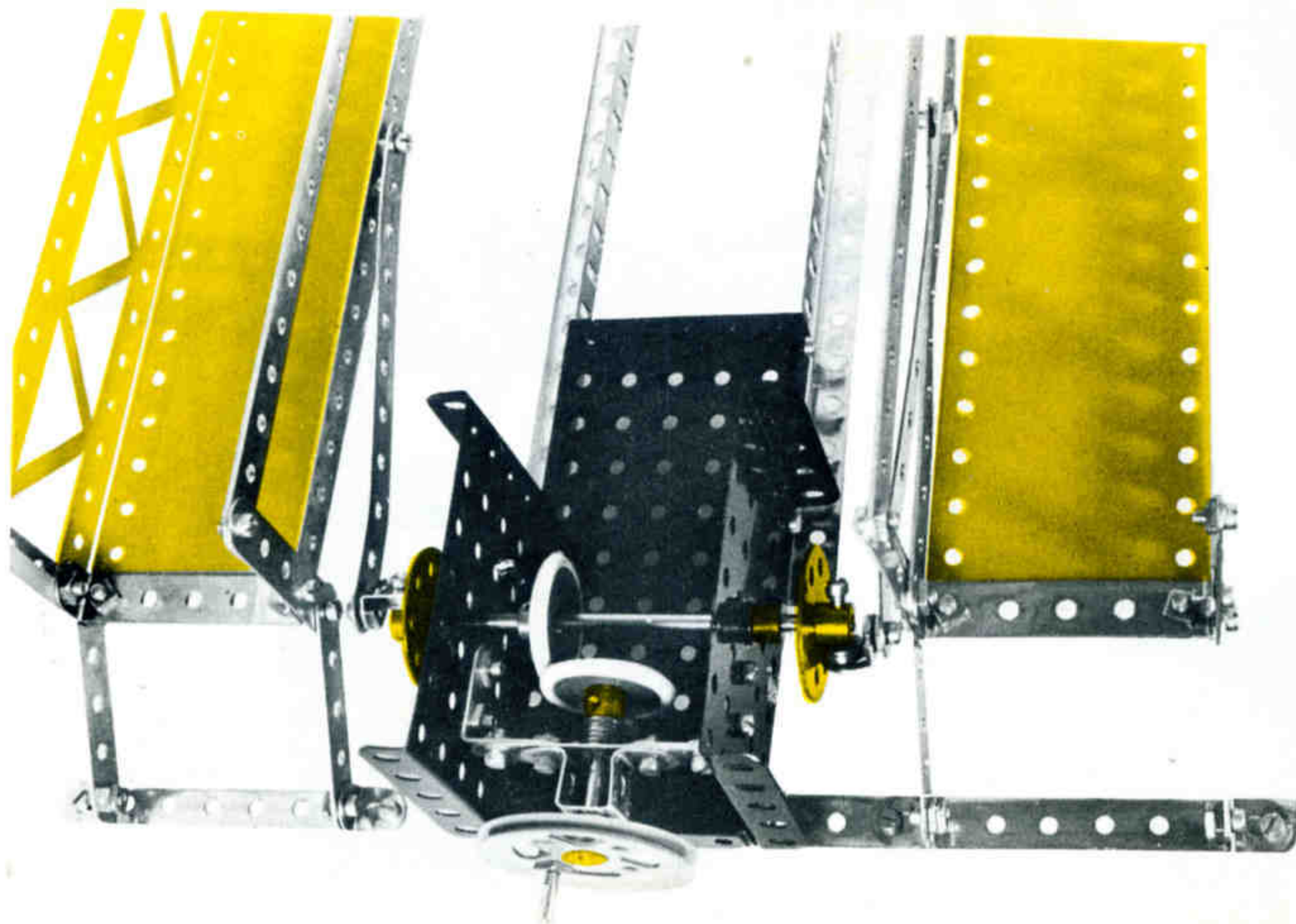

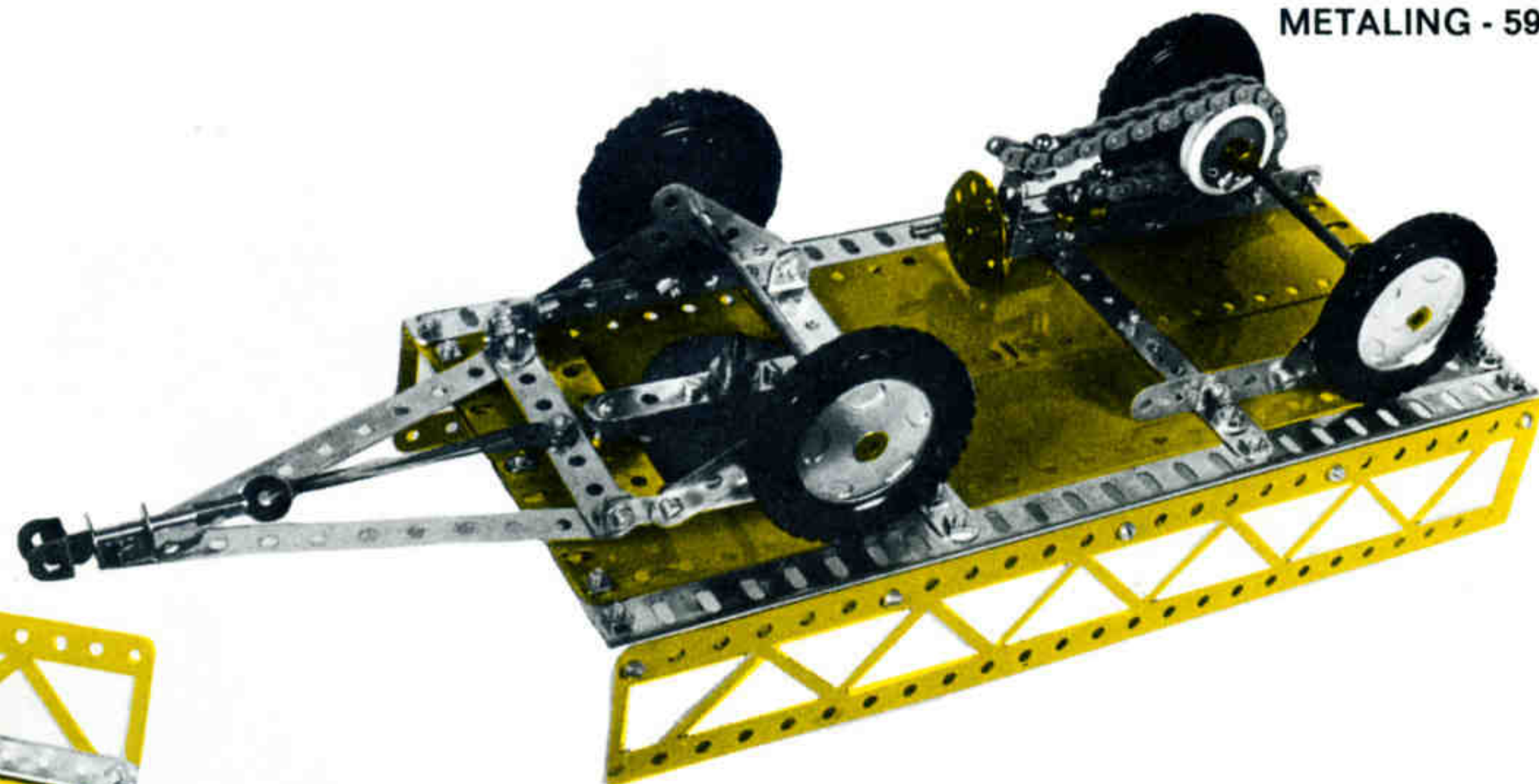
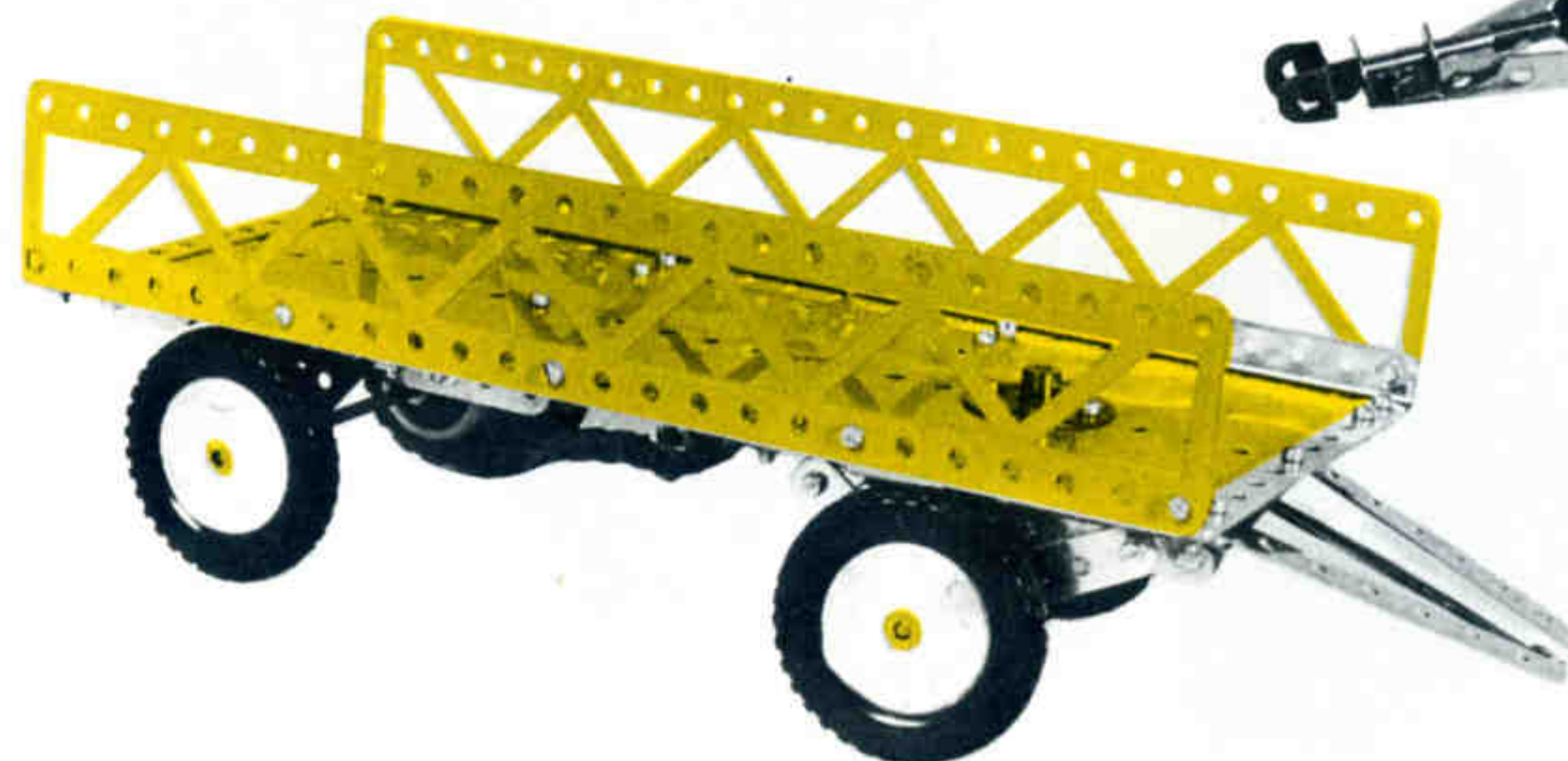

**REMOLQUE 6/275**

8 - 2	10 - 38
2 - 3	1 - 48a
8 - 5	2 - 48b
1 - 6a	2 - 59
2 - 8	1 - 80c
2 - 10	2 - 99
2 - 11	2 - 111
7 - 12	2 - 111c
2 - 15	1 - 115
1 - 17	2 - 155
1 - 18a	1 - 186a
1 - 20a	4 - 187
2 - 22	2 - 197
1 - 23a	1 - 212
2 - 24	2 - 235
2 - 35	2 - 235b
67 - 37a	21 - 374
58 - 37b	

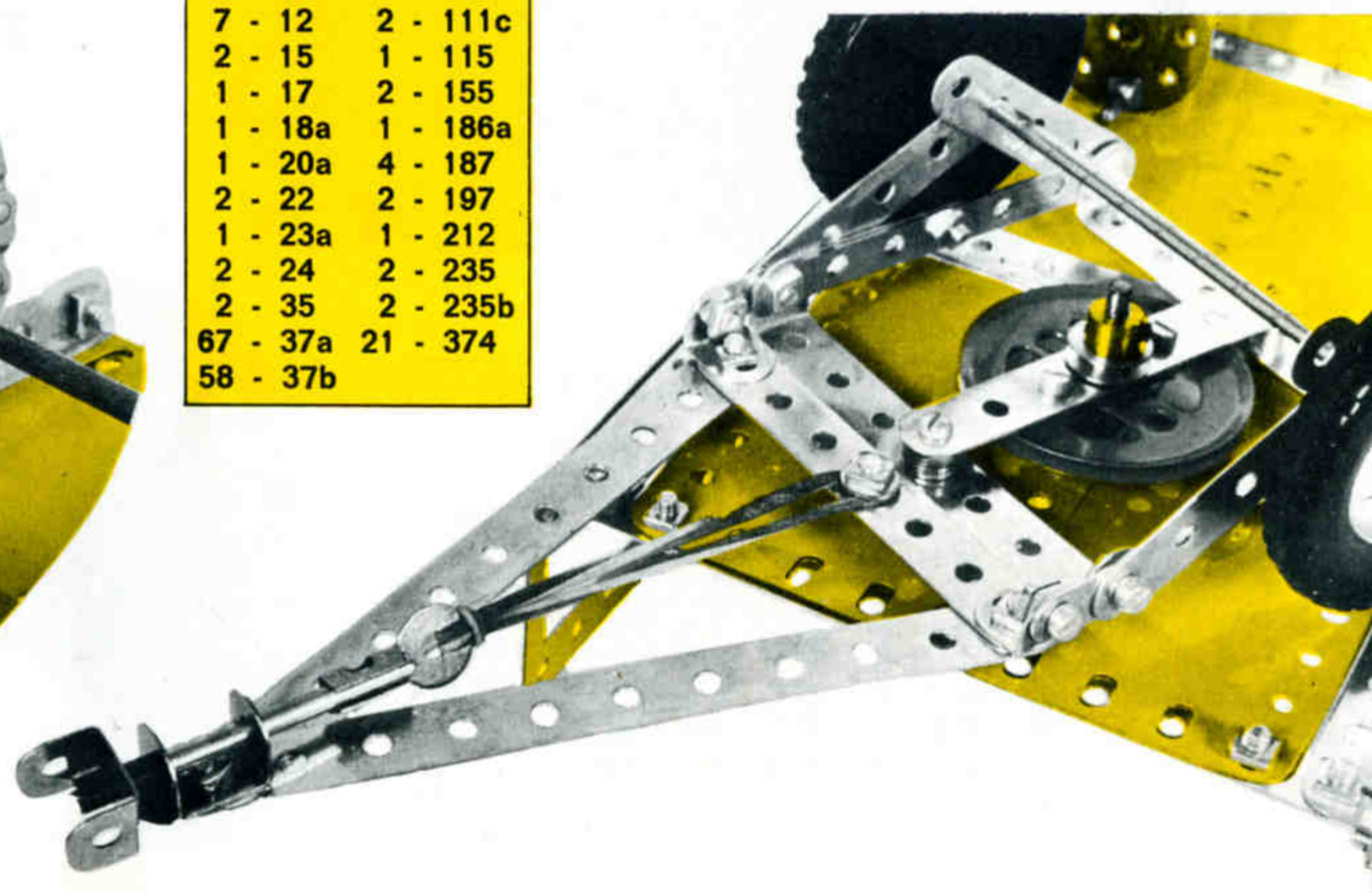
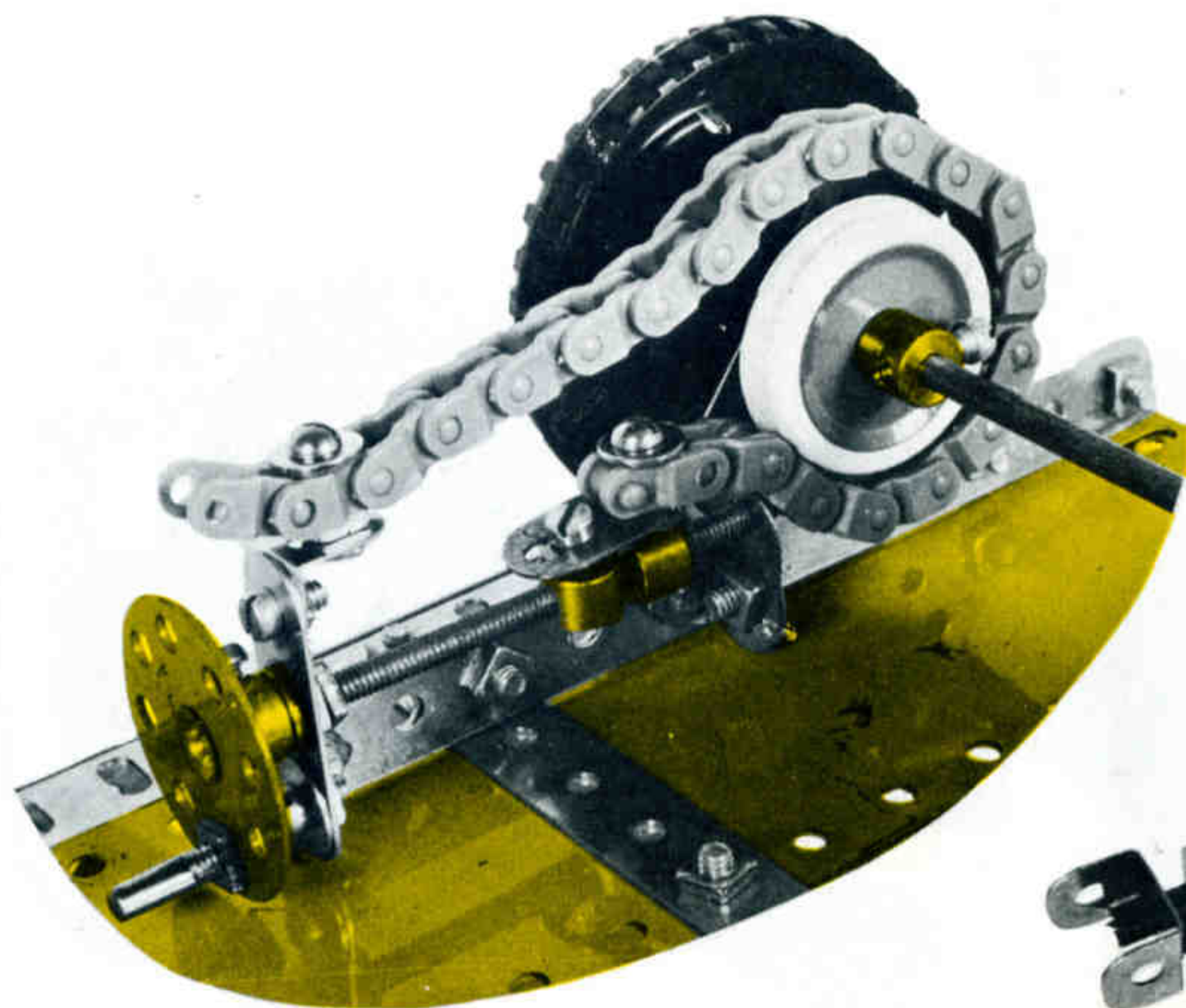

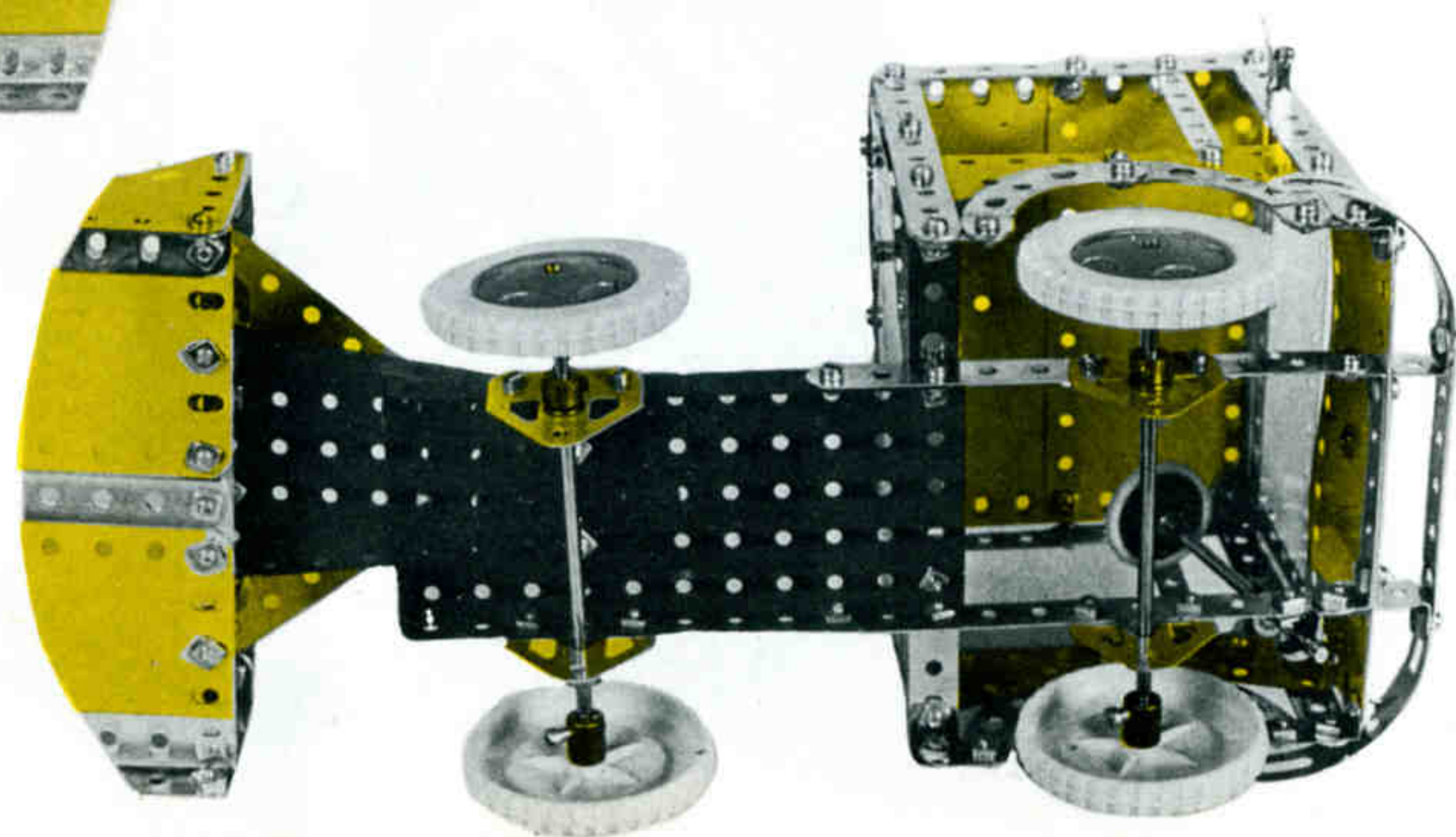
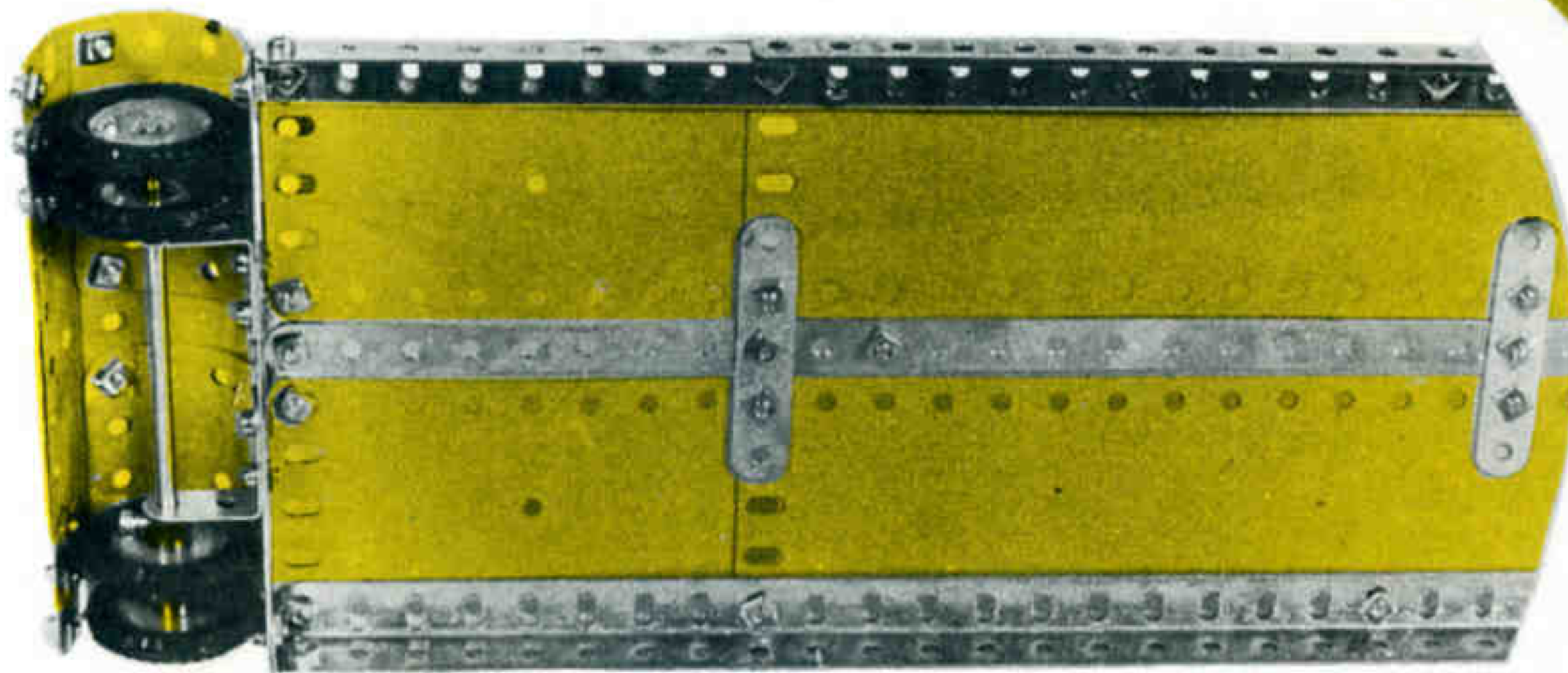
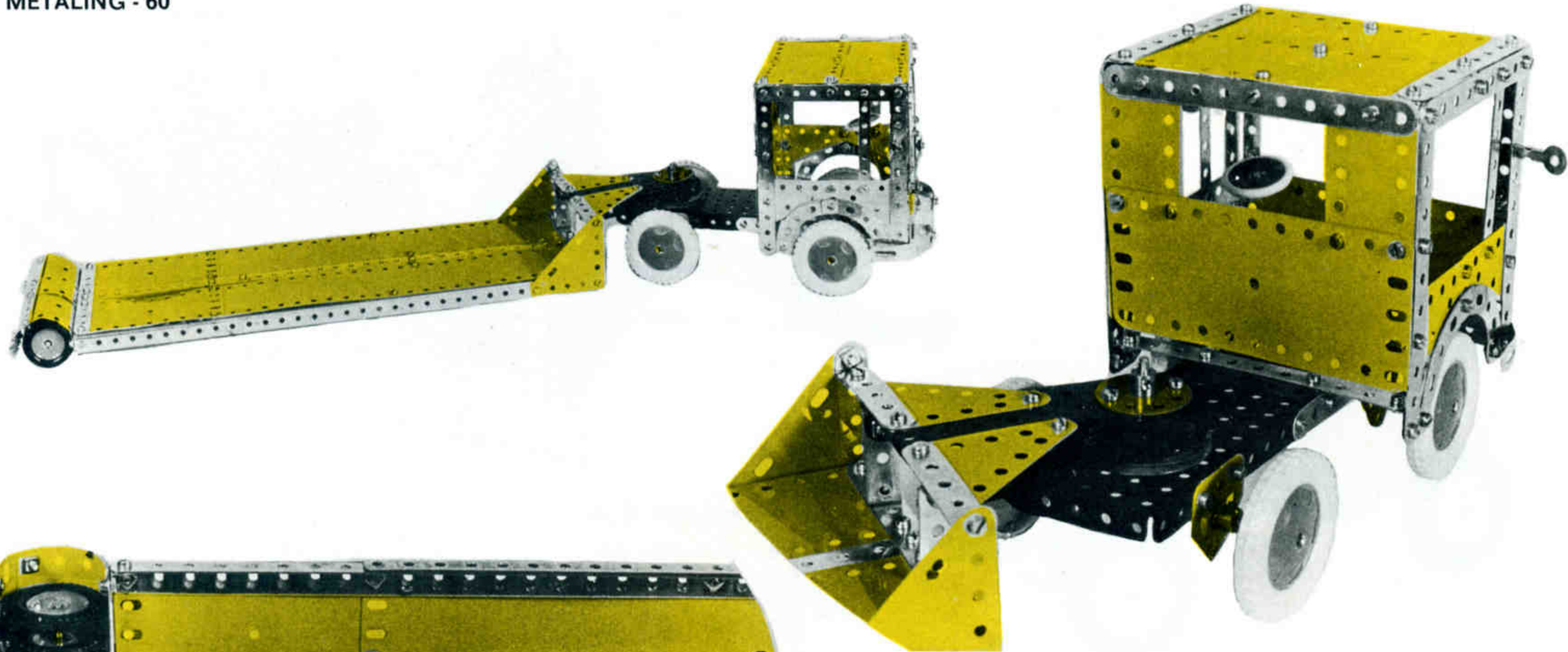

**CAMION TRANSPORTES PESADOS 6/276**

1 - 1	1 - 15a	2 - 38d	4 - 126a	1 - 193e
14 - 2	1 - 15b	2 - 48	4 - 142c	2 - 197
2 - 3	1 - 17	1 - 48a	1 - 155	2 - 212
14 - 5	1 - 20a	1 - 52	4 - 187	2 - 215
4 - 8	5 - 22	1 - 54	3 - 188	2 - 222
4 - 10	1 - 24	4 - 59	1 - 189	2 - 223
1 - 11	2 - 35	4 - 90a	2 - 190	2 - 235
16 - 12	139 - 37a	2 - 111	2 - 191	4 - 235b
2 - 12a	119 - 37b	4 - 111c	4 - 192	
2 - 15	15 - 38	2 - 125	1 - 193c	

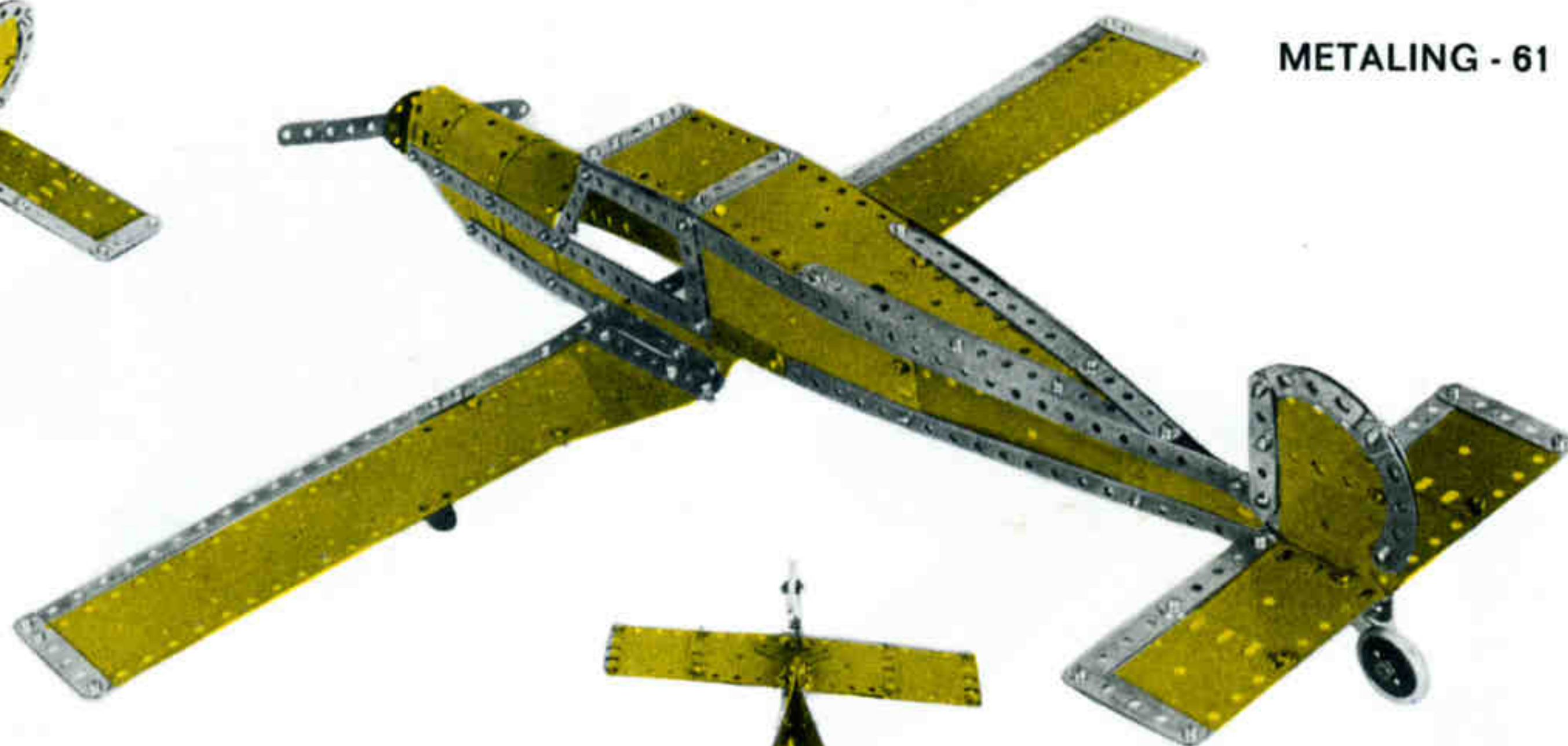
**AVIONETA DE TURISMO 6/277**

8 - 1	125 - 37b	4 - 189
10 - 2	134 - 37a	5 - 190
4 - 3	1 - 45	2 - 191
2 - 4	1 - 48	4 - 192
14 - 5	4 - 48a	1 - 193a
2 - 6a	1 - 59	2 - 197
4 - 10	4 - 90a	2 - 214
10 - 12	2 - 111	4 - 221
2 - 12a	1 - 111a	2 - 223
1 - 18a	2 - 111c	3 - 235
2 - 22	2 - 142c	3 - 235a
1 - 22a	1 - 155	
1 - 24	4 - 188	

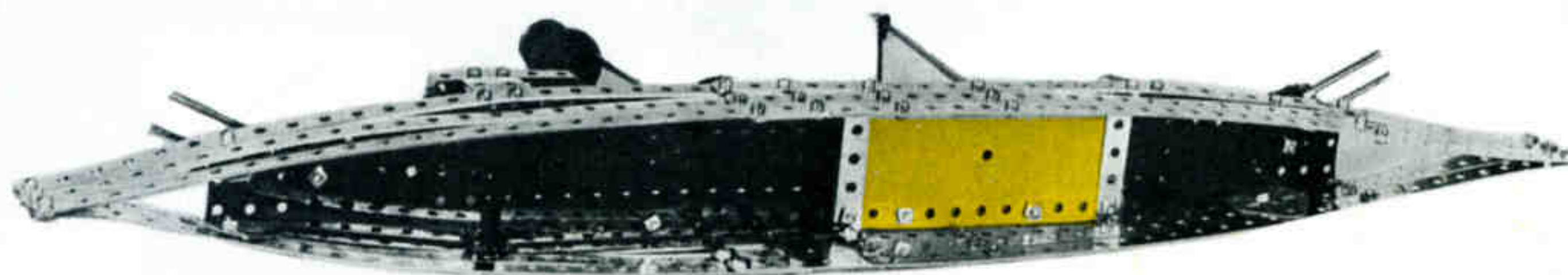
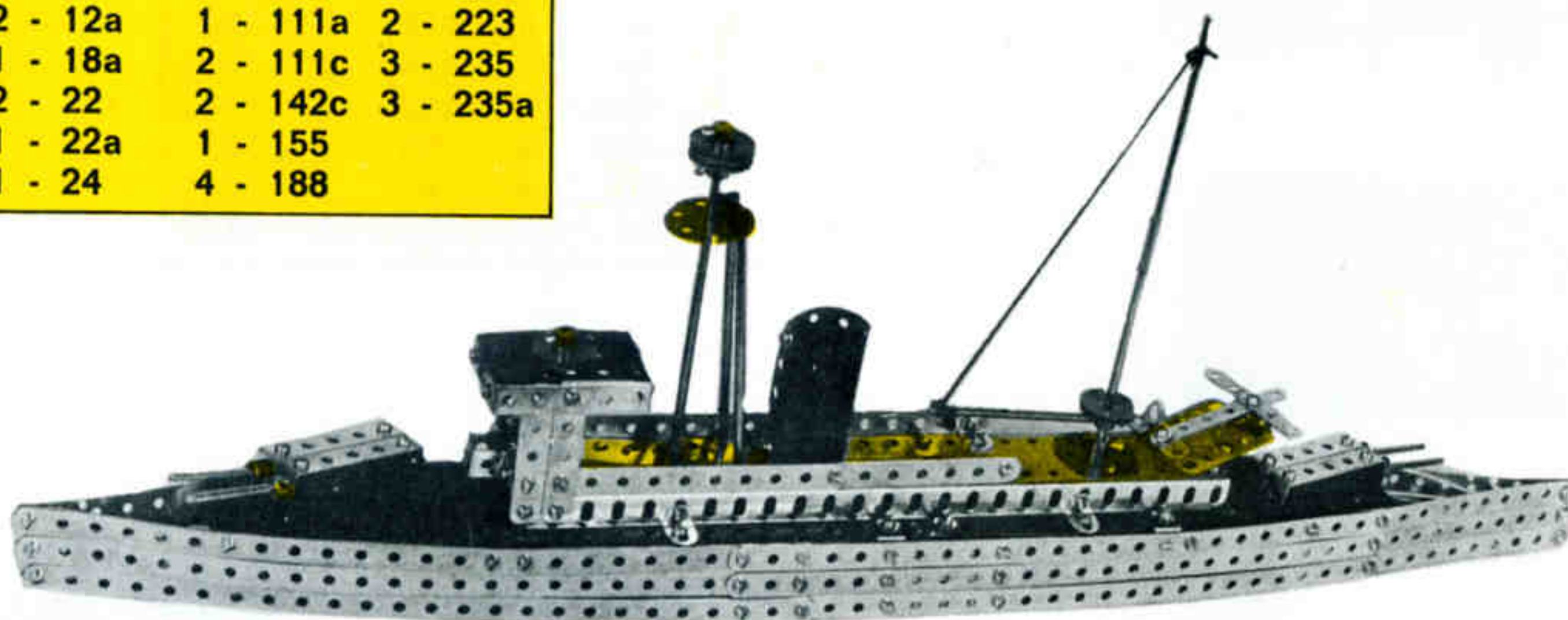
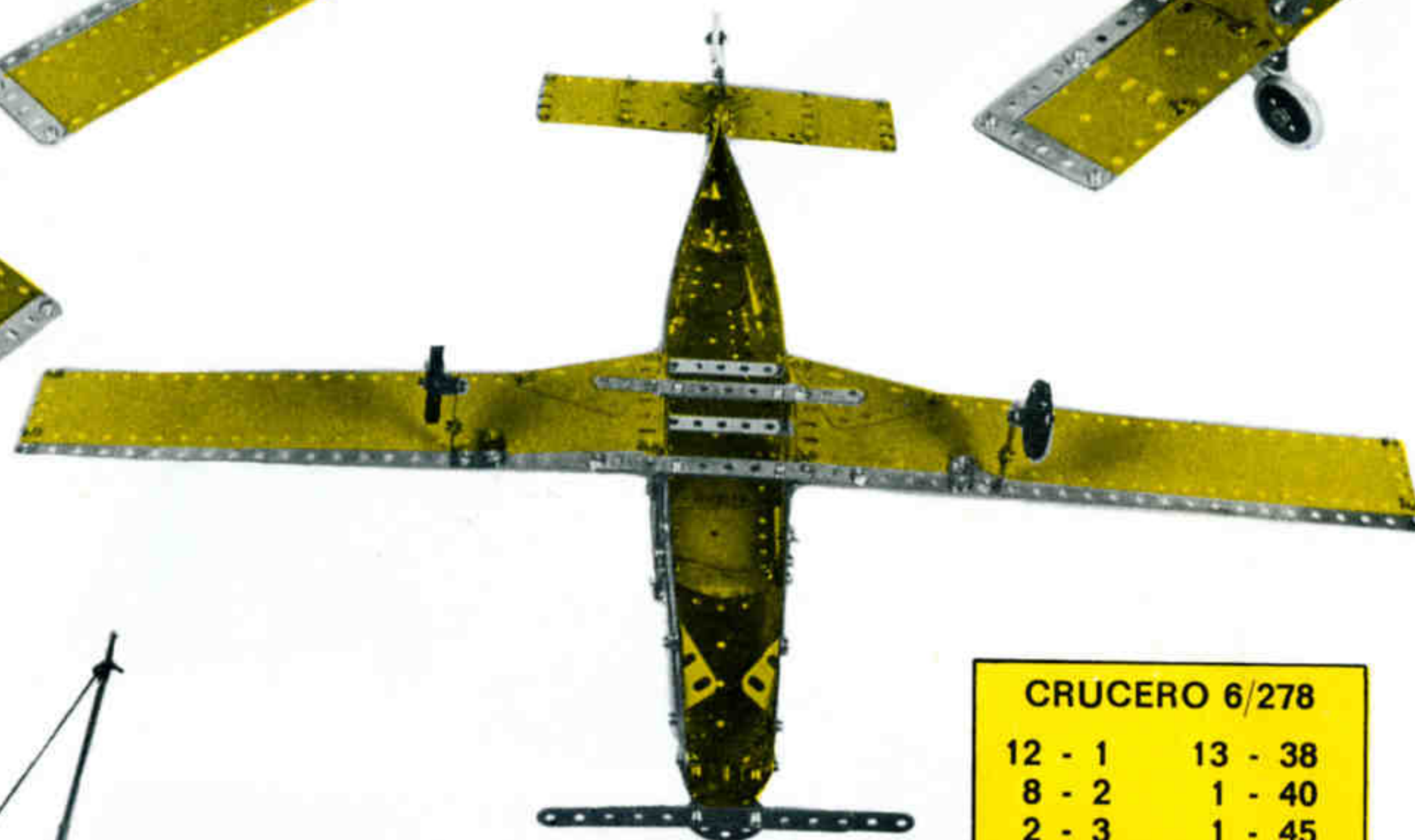

**CRUCERO 6/278**

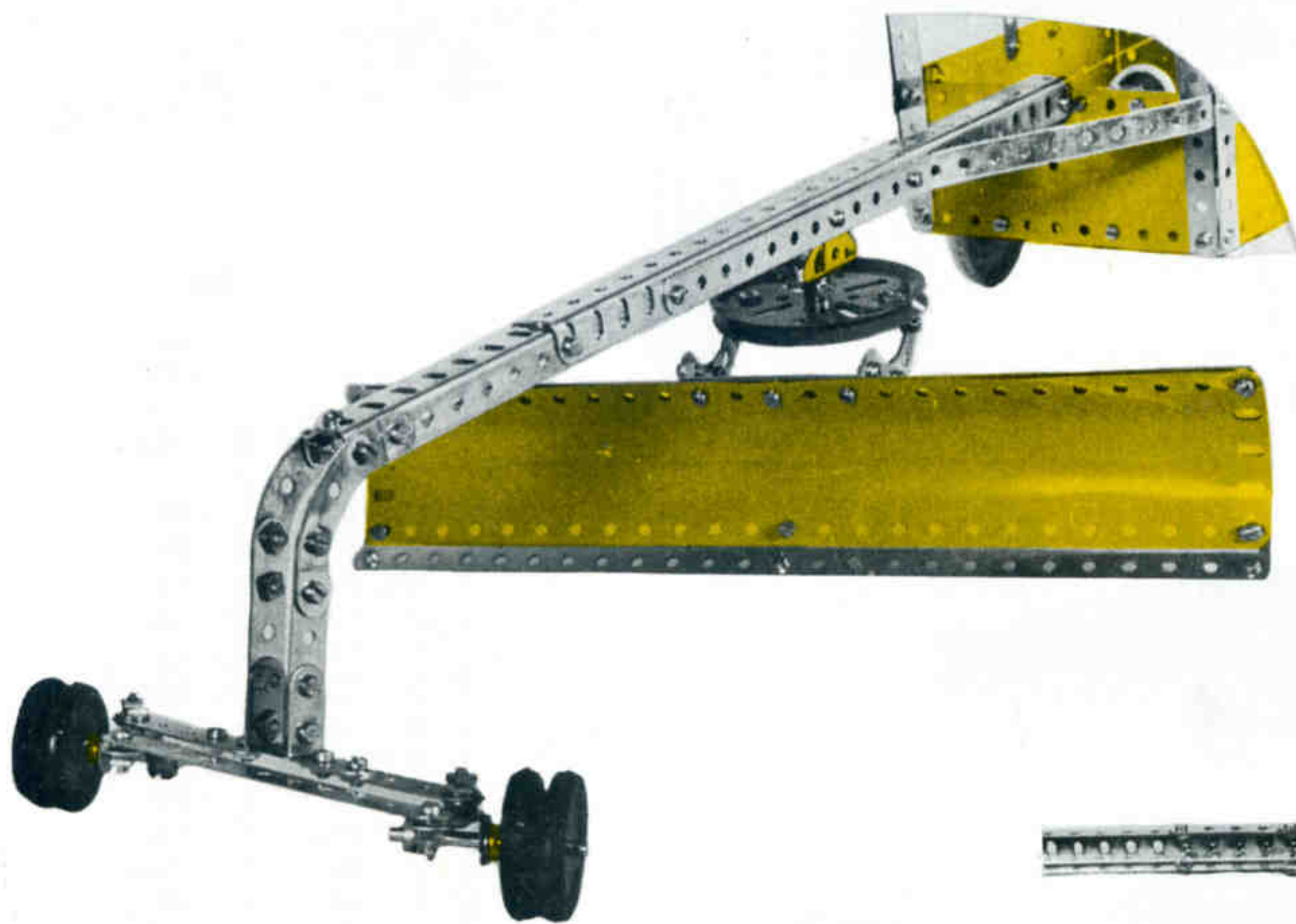
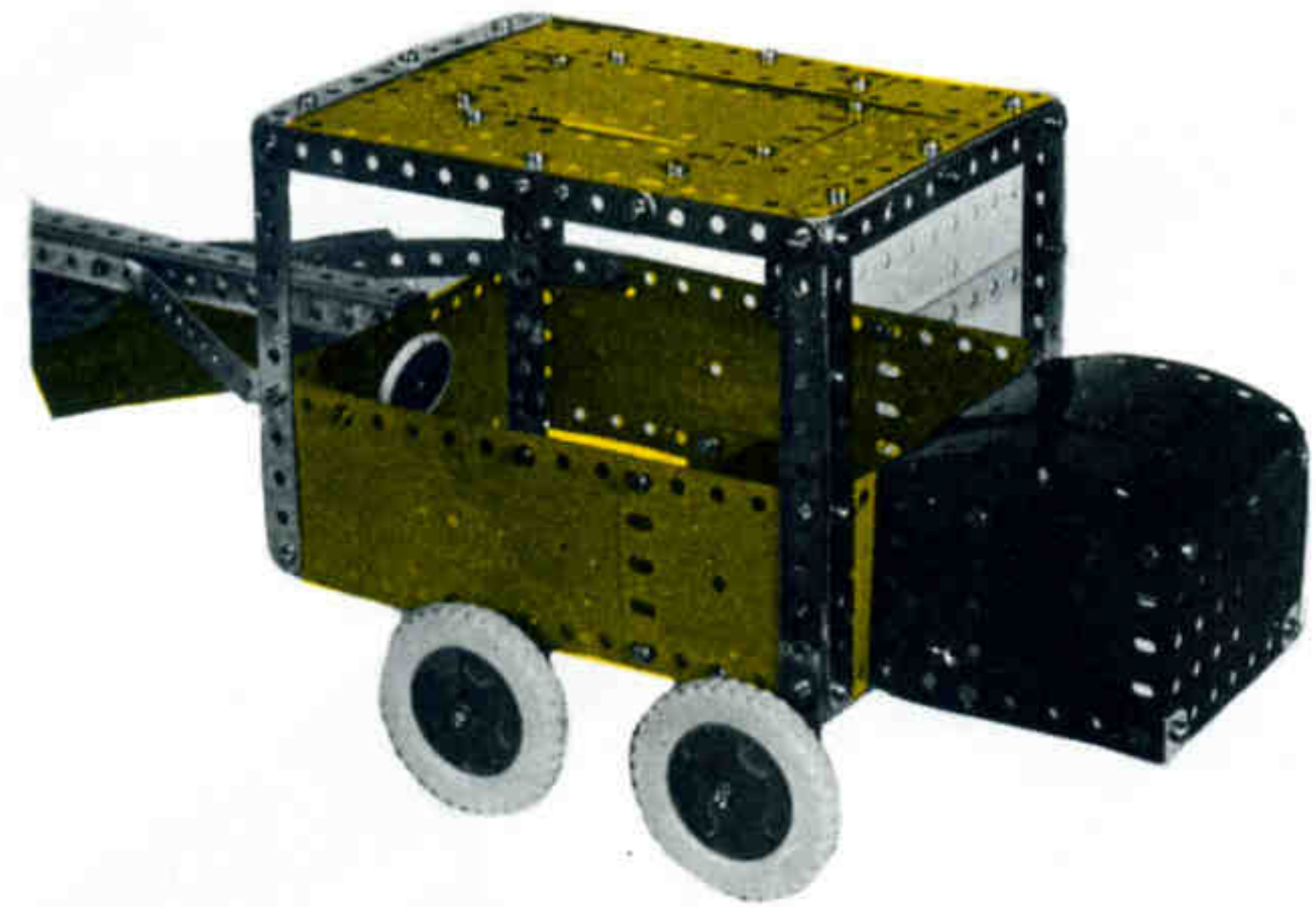
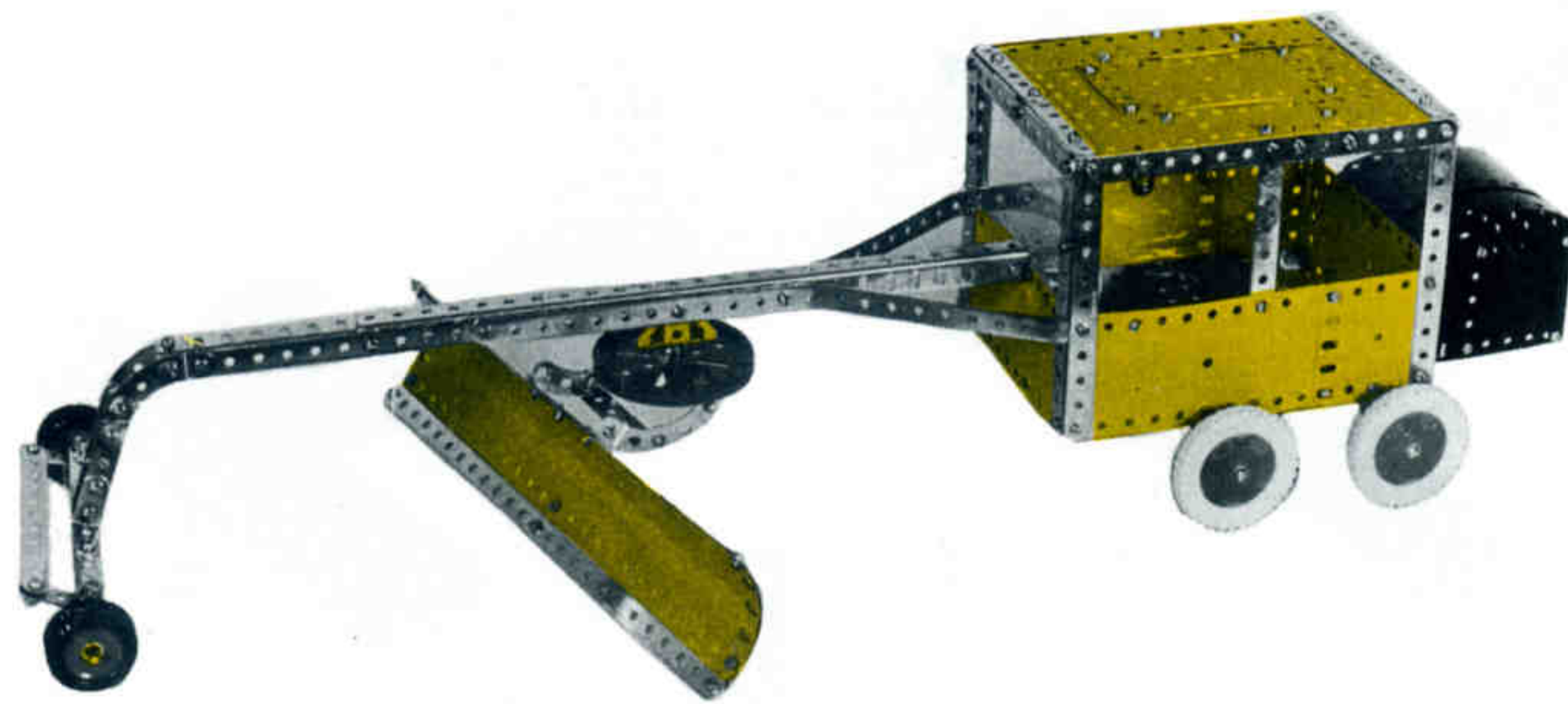
12 - 1	13 - 38
8 - 2	1 - 40
2 - 3	1 - 45
4 - 5	8 - 48a
2 - 6a	1 - 51
2 - 8	1 - 52
4 - 10	2 - 54
1 - 11	4 - 59
12 - 12	1 - 80c
1 - 14	4 - 111c
2 - 15	4 - 126a
2 - 15b	4 - 188
4 - 16	2 - 189
5 - 22	1 - 192
1 - 23a	1 - 194
2 - 24	2 - 194a
1 - 24c	2 - 194c
9 - 35	1 - 213
122 - 37a	1 - 235
117 - 37b	1 - 235a

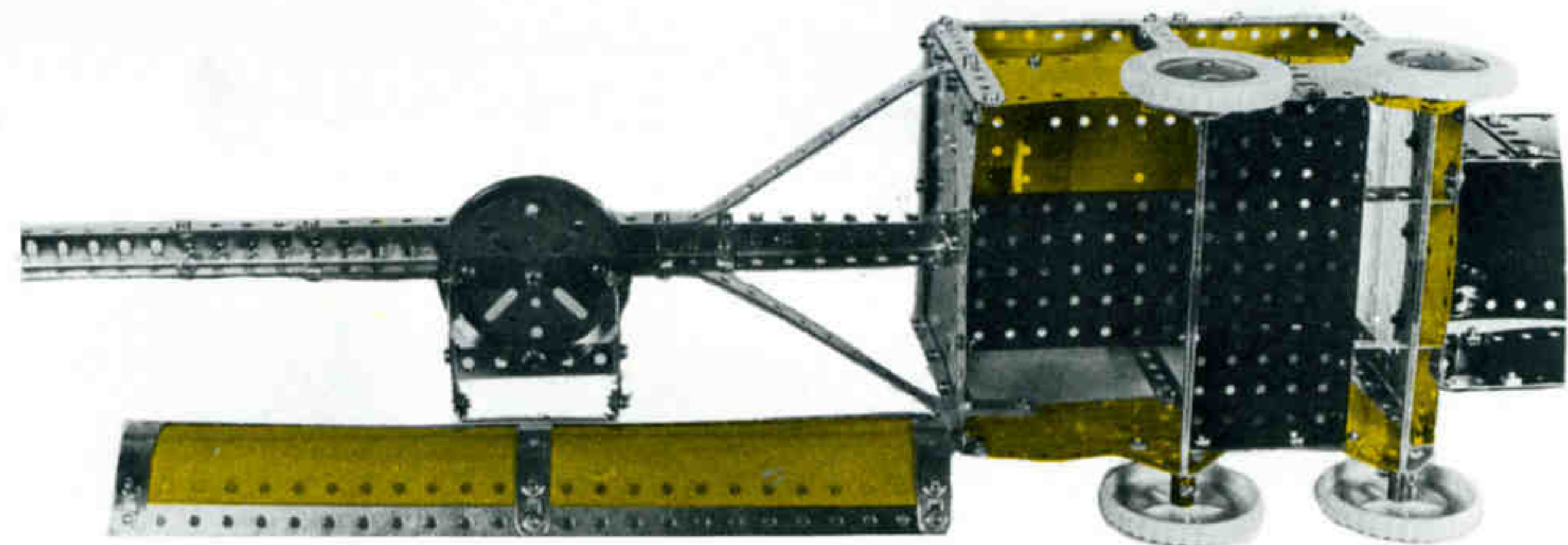

**MOTONIVELADORA 6/279**

4 - 1	2 - 17	2 - 53a	2 - 189
14 - 2	1 - 19b	3 - 59	2 - 190
4 - 3	5 - 22	4 - 90a	1 - 191
2 - 4	153 - 37a	1 - 111	4 - 192
4 - 5	122 - 37b	2 - 111a	2 - 193d
2 - 6a	6 - 38	5 - 111c	1 - 193e
4 - 8	1 - 45	2 - 126	2 - 194
3 - 11	2 - 48	4 - 126a	2 - 194a
14 - 12	3 - 48a	4 - 142c	2 - 194c
2 - 12a	2 - 48b	1 - 155	1 - 197
1 - 11a	1 - 52	4 - 187	2 - 213
4 - 16	2 - 53	2 - 188	3 - 215





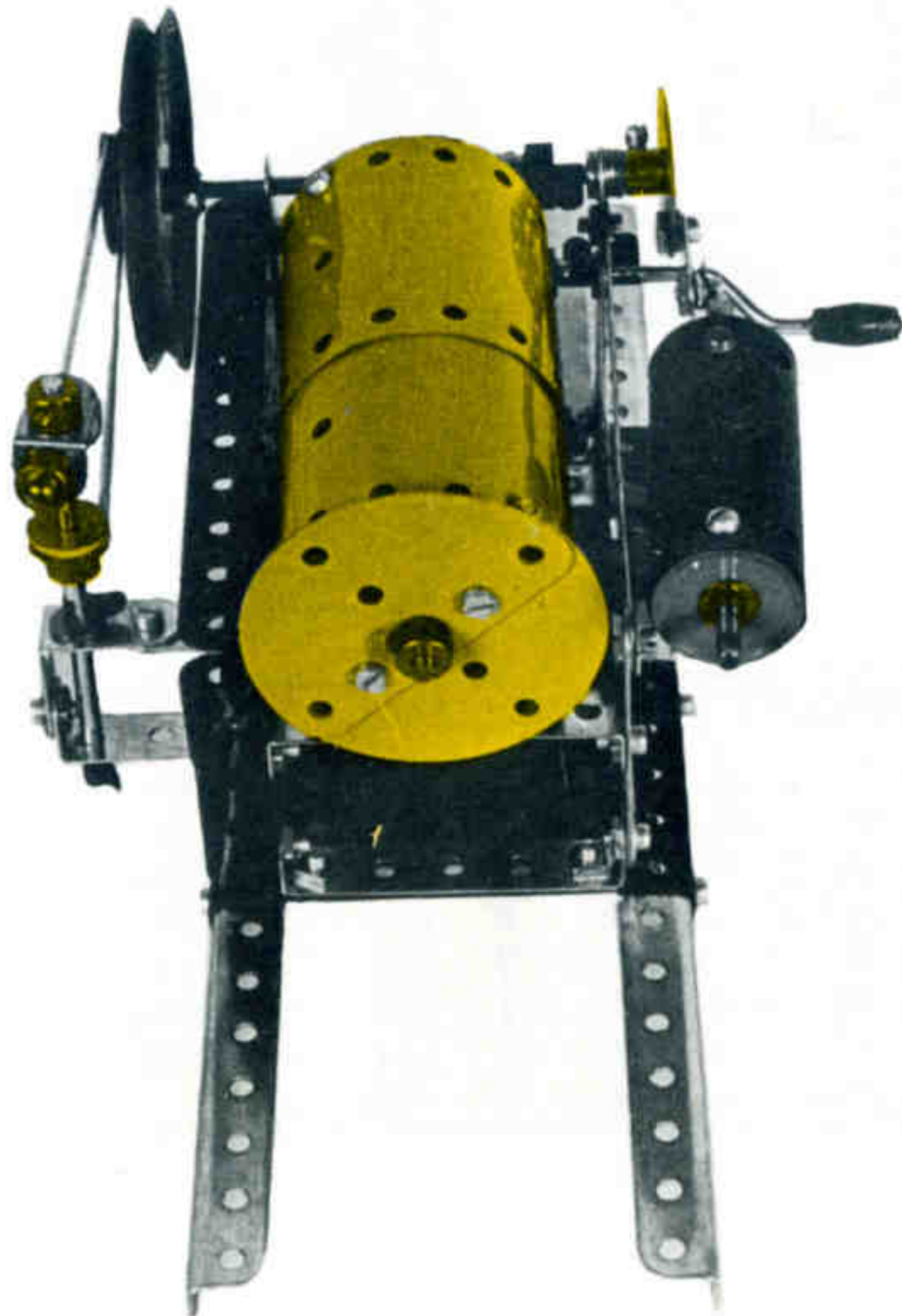
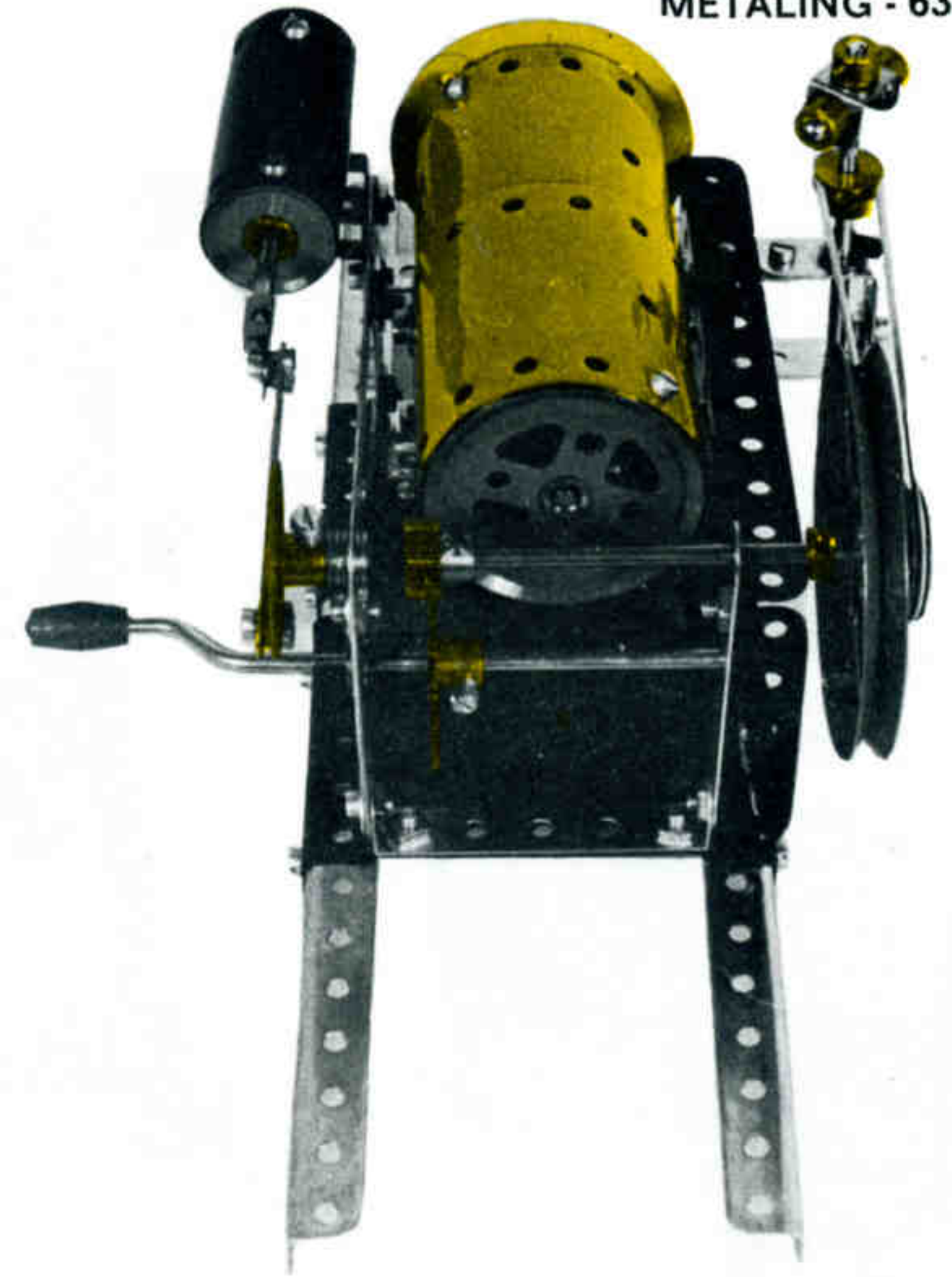
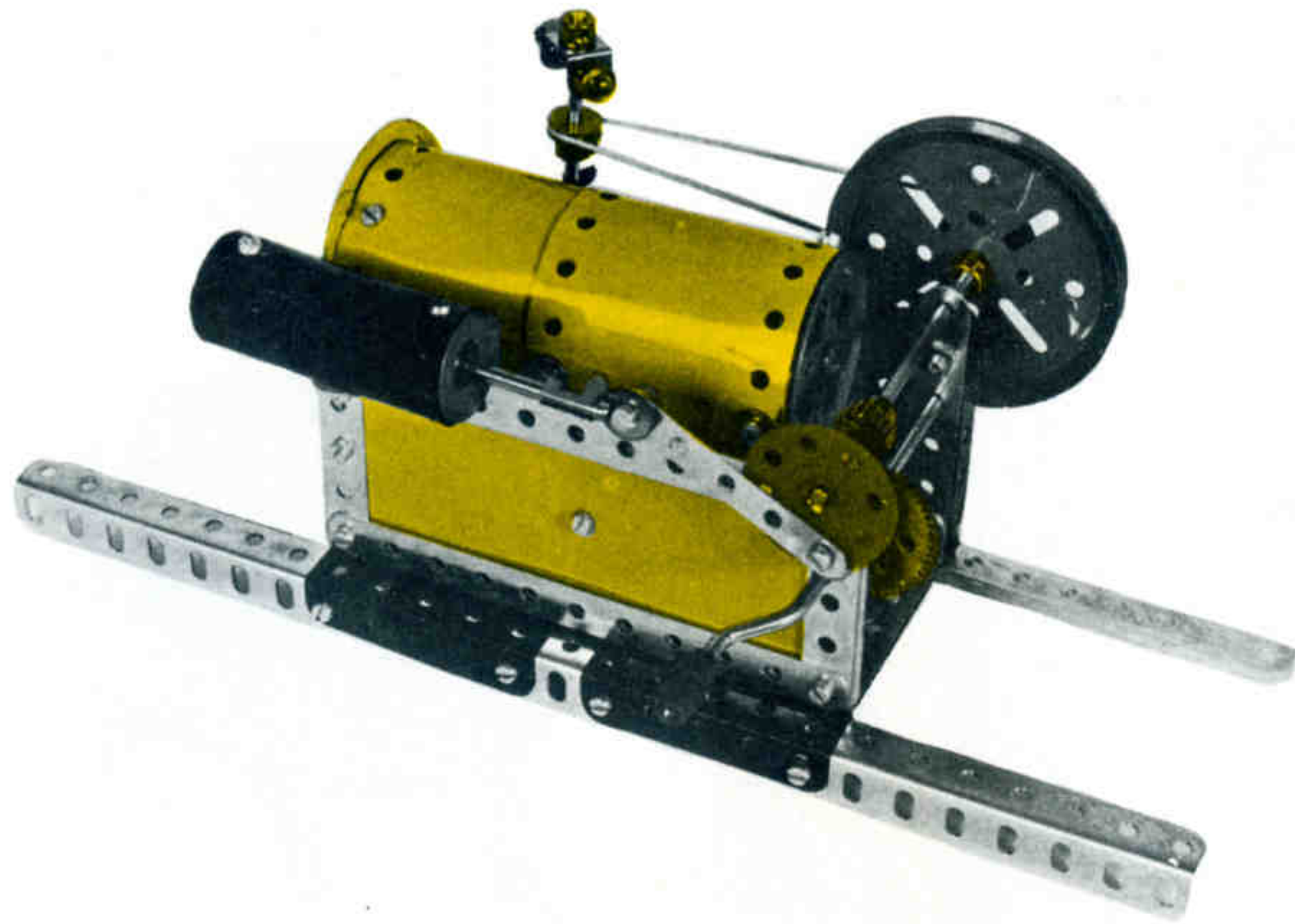

**MAQUINA DE VAPOR 6/280**

2 - 2	48 - 37a
2 - 4	42 - 37b
1 - 5	18 - 38
2 - 8	1 - 48
1 - 11	4 - 48a
2 - 12	1 - 52
2 - 12a	2 - 53
1 - 15	4 - 59
1 - 15a	2 - 111a
1 - 15b	2 - 111a
1 - 16	4 - 111c
1 - 19b	1 - 126
1 - 19g	1 - 186b
1 - 20a	2 - 190
3 - 22	2 - 191
1 - 23a	1 - 192
1 - 24	1 - 194c
1 - 26	1 - 212
1 - 27a	2 - 214
5 - 35	1 - 235

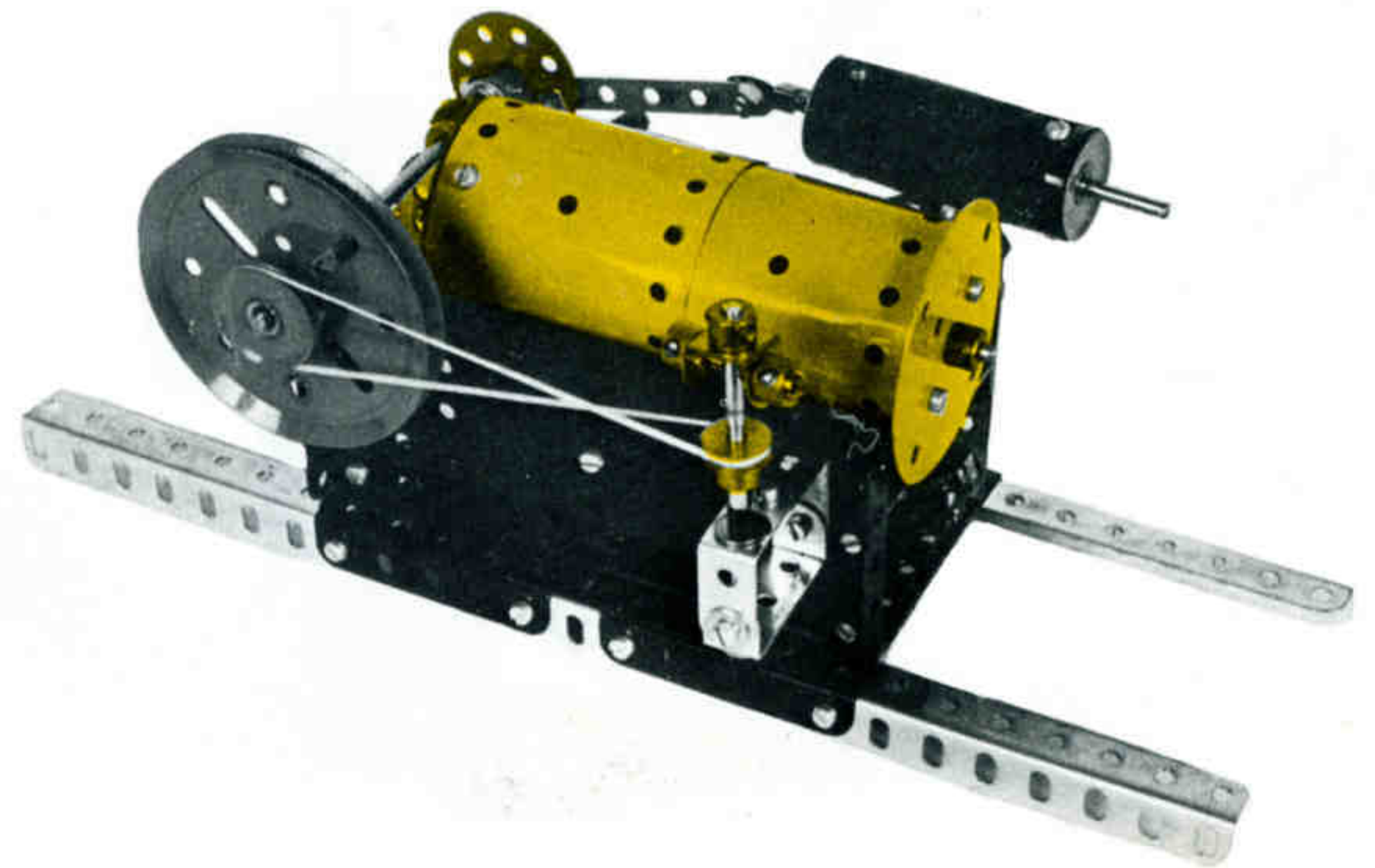

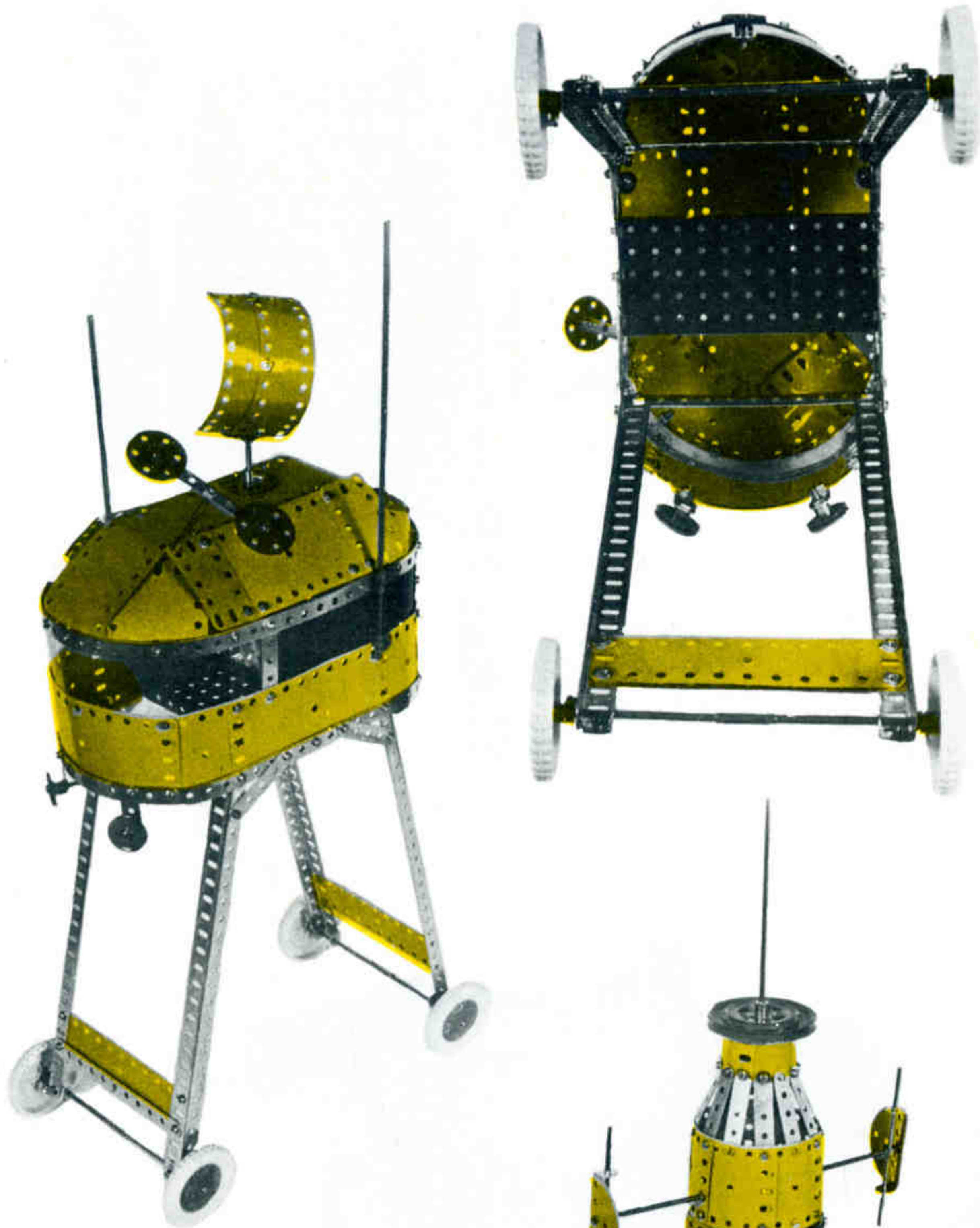

**VEHICULO LUNAR  
6/281**

2 - 1	6 - 111c
10 - 2	1 - 147b
2 - 3	4 - 187
10 - 5	4 - 188
2 - 6a	6 - 190
4 - 8	2 - 191
7 - 12	4 - 192
8 - 12c	2 - 189
1 - 13	2 - 193
1 - 14	2 - 193a
4 - 16	2 - 193d
1 - 18a	1 - 193e
3 - 22	2 - 194a
2 - 24	1 - 194c
2 - 24c	1 - 197
92 - 37b	1 - 199
99 - 37a	1 - 200
1 - 52	1 - 212
1 - 80c	2 - 212a
2 - 111	2 - 213
1 - 111a	1 - 235b

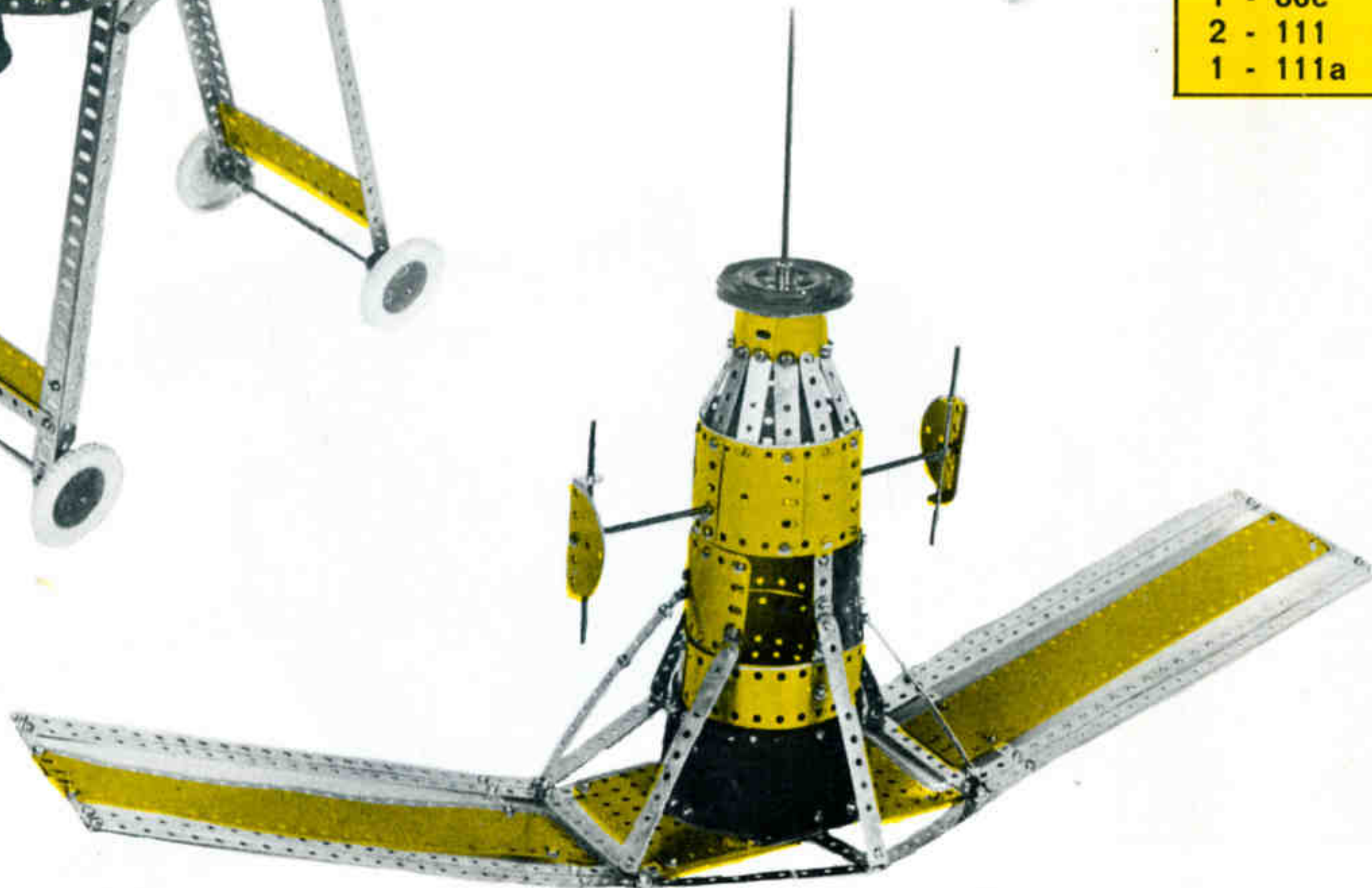

**SATELITE METEOROLOGICO 6/282**

10 - 1	1 - 14	2 - 53a	2 - 194
14 - 2	2 - 15	2 - 59	2 - 194a
3 - 3	1 - 19b	2 - 80c	2 - 194c
2 - 4	1 - 20a	3 - 188	2 - 197
14 - 5	145 - 37a	3 - 189	2 - 214
3 - 10	140 - 37b	6 - 190	4 - 235a
10 - 12	18 - 38	2 - 191	4 - 235b
6 - 12c	4 - 48a	1 - 193c	

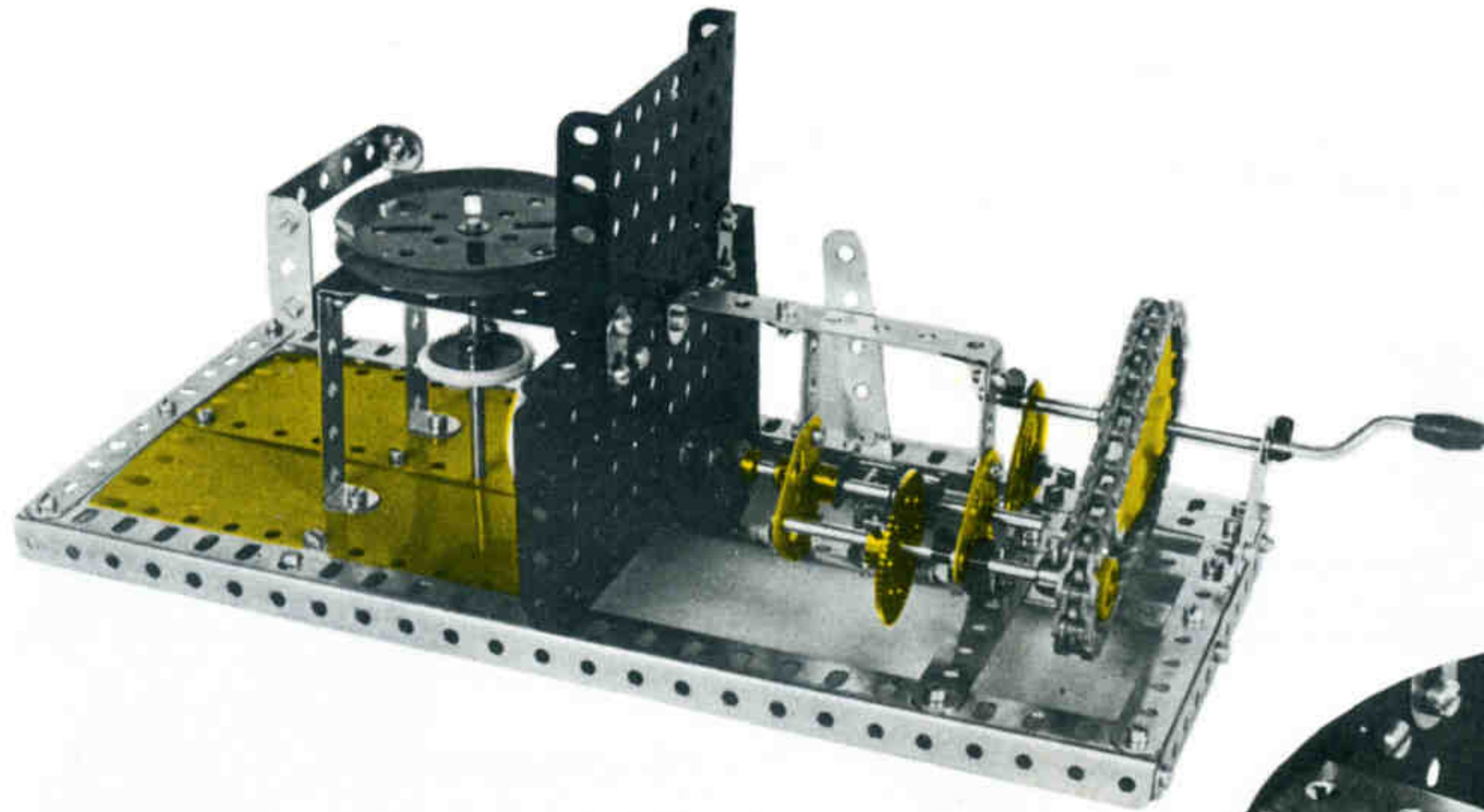

**MAQUINA CERAMICA 6/283**

1 - 1	1 - 19g	2 - 53
5 - 2	4 - 22	2 - 59
1 - 3	1 - 26	1 - 91
2 - 6a	1 - 27a	1 - 92
2 - 8	6 - 35	4 - 126a
2 - 10	60 - 37a	2 - 142c
1 - 11	58 - 37b	2 - 155
6 - 12	7 - 38	2 - 192
3 - 16	8 - 48a	29 - 374
1 - 17	1 - 48b	
1 - 19b	1 - 52	

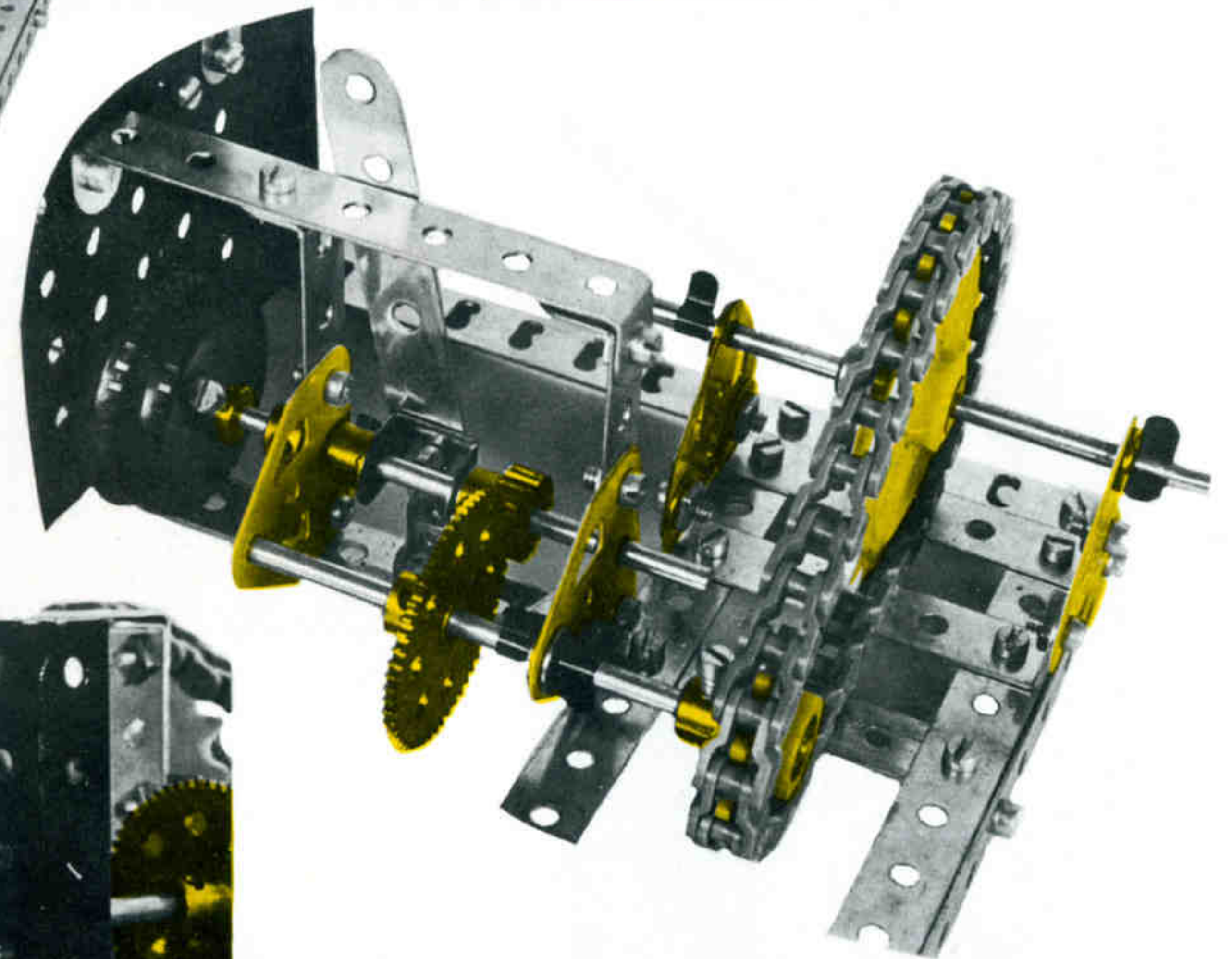
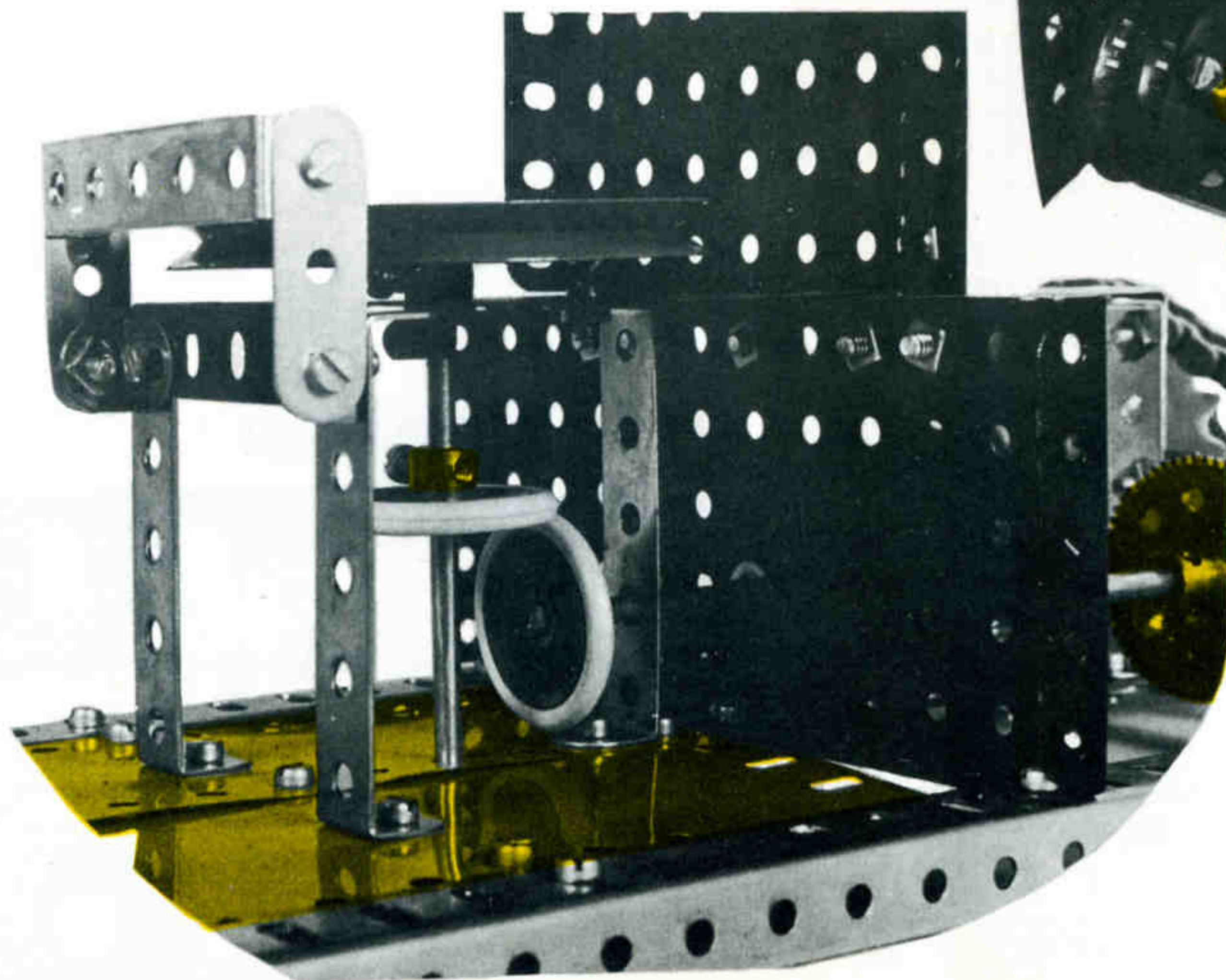

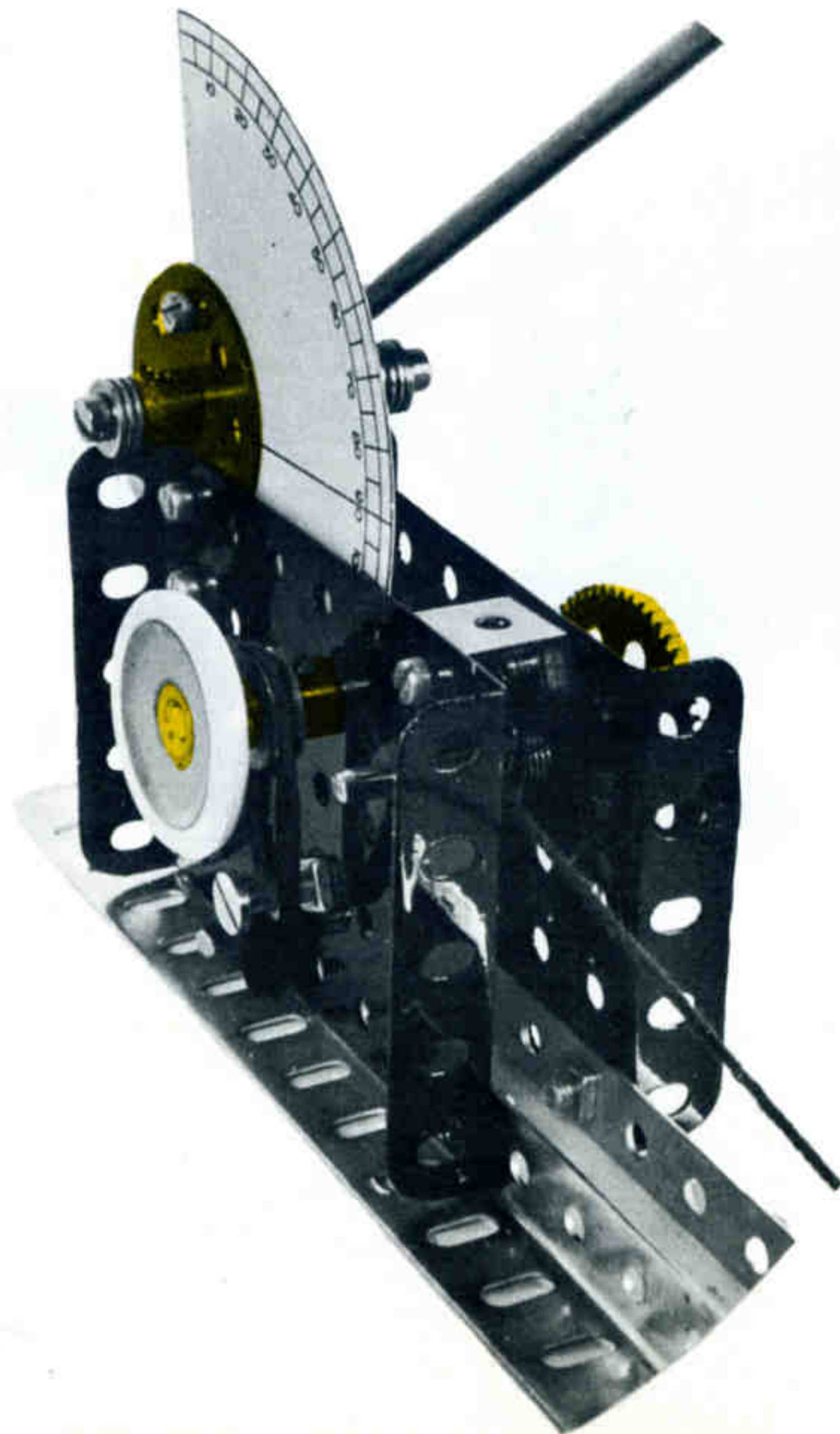
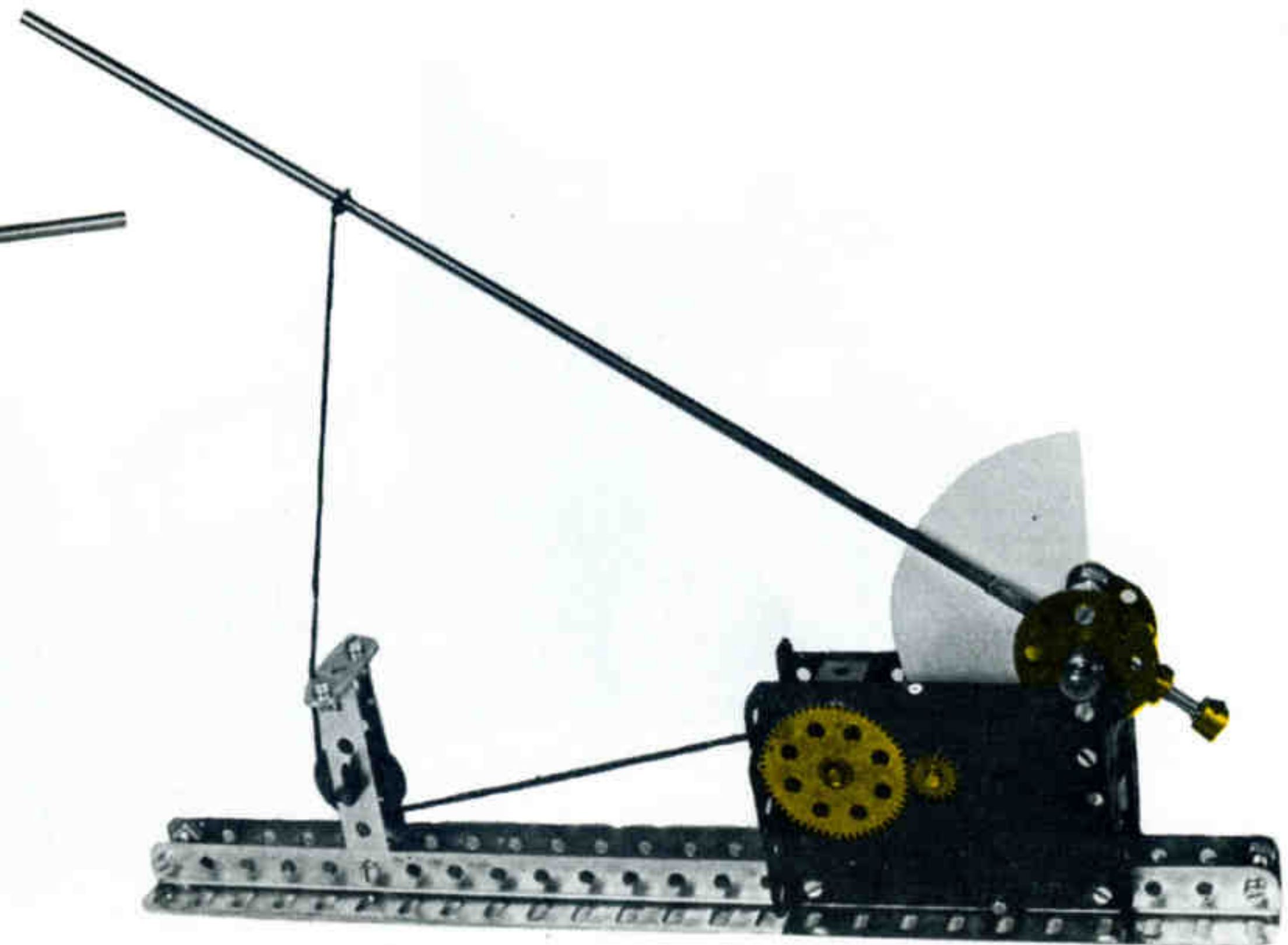
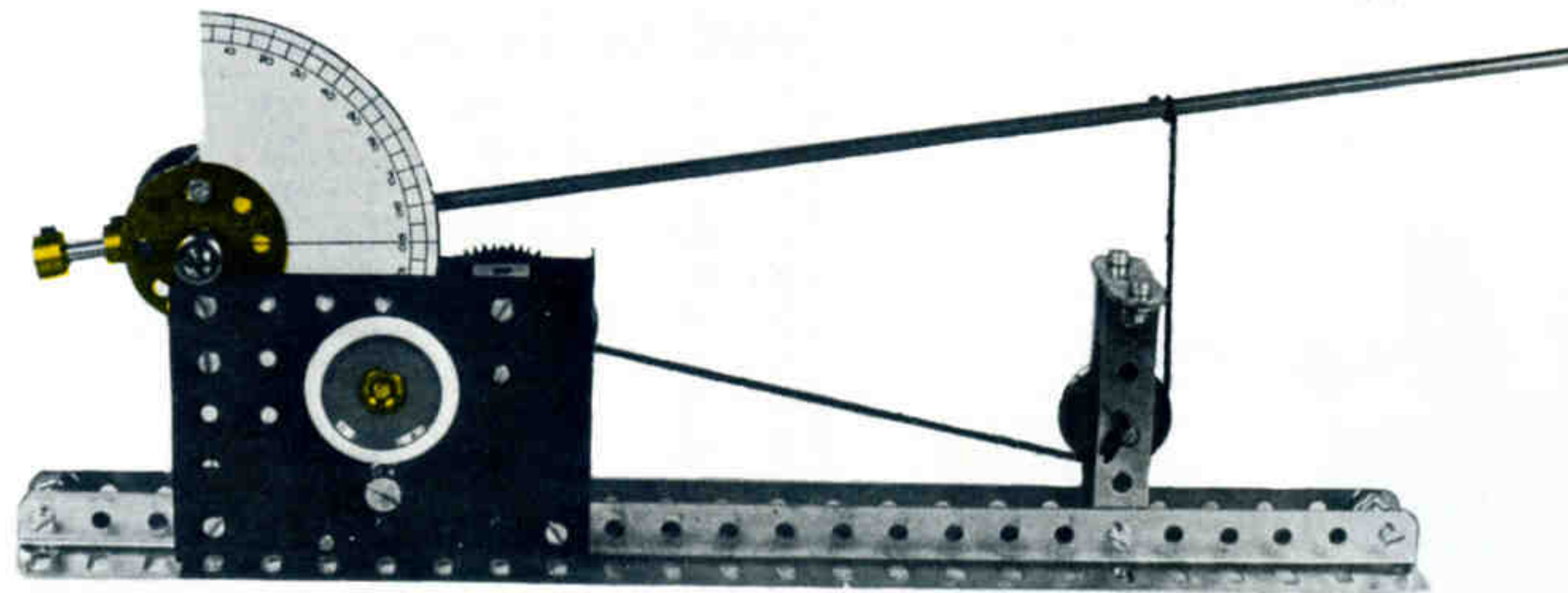

**APARATO PARA MEDIR ANGULOS  
VERTICALES 6/284**

2 - 5	1 - 22	20 - 37b	1 - 176
1 - 6a	1 - 22a	6 - 38	1 - 186
2 - 8	1 - 23a	1 - 40	1 - 186a
4 - 11	2 - 24	2 - 53	1 - 213
1 - 13	1 - 26	3 - 59	2 - 48a
2 - 17	1 - 27a	2 - 111	
2 - 18a	4 - 35	1 - 147b	
1 - 18b	20 - 37a	1 - 155	

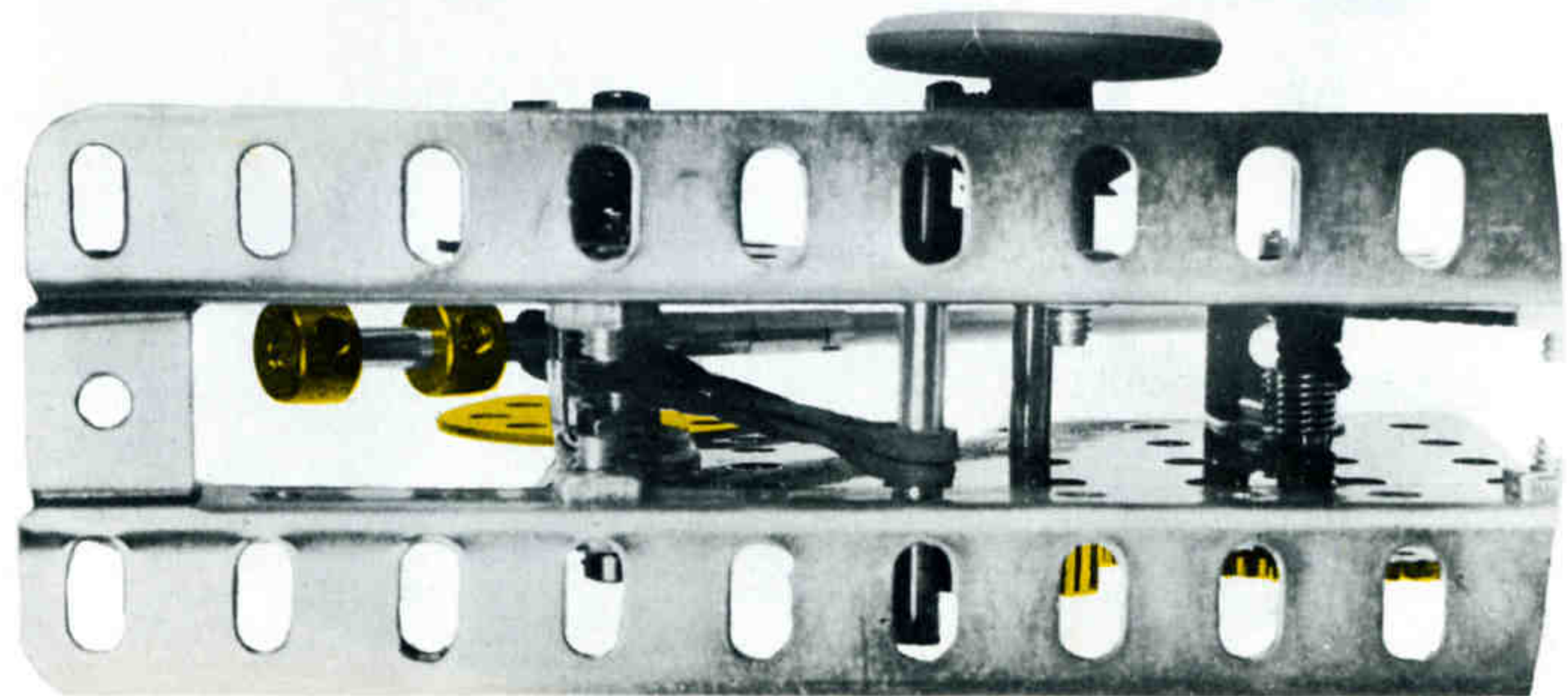

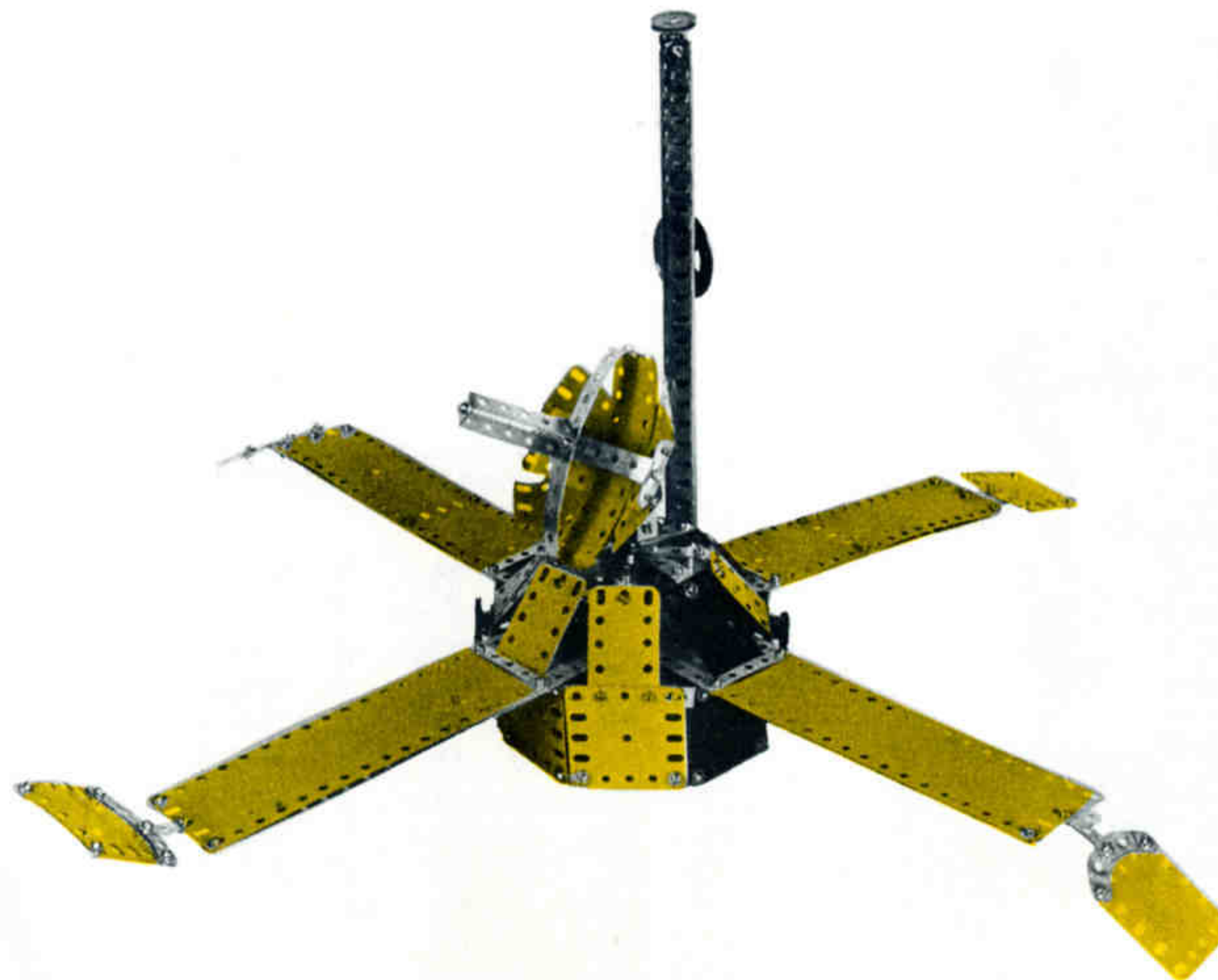

**MARINER IV SONDA MARCIANA 6/285**

4 - 1	1 - 18a	1 - 80a	2 - 197
7 - 2	1 - 20a	4 - 90a	1 - 199
4 - 3	3 - 22	6 - 111c	1 - 200
8 - 5	2 - 24	4 - 188	4 - 221
2 - 6a	127 - 37a	4 - 189	2 - 222
2 - 8	120 - 37b	6 - 190	2 - 223
1 - 10	19 - 38	4 - 192	4 - 235
2 - 11	22 - 48	2 - 133a	4 - 235a
16 - 12	3 - 48a	2 - 194	
8 - 12c	1 - 59	2 - 194a	

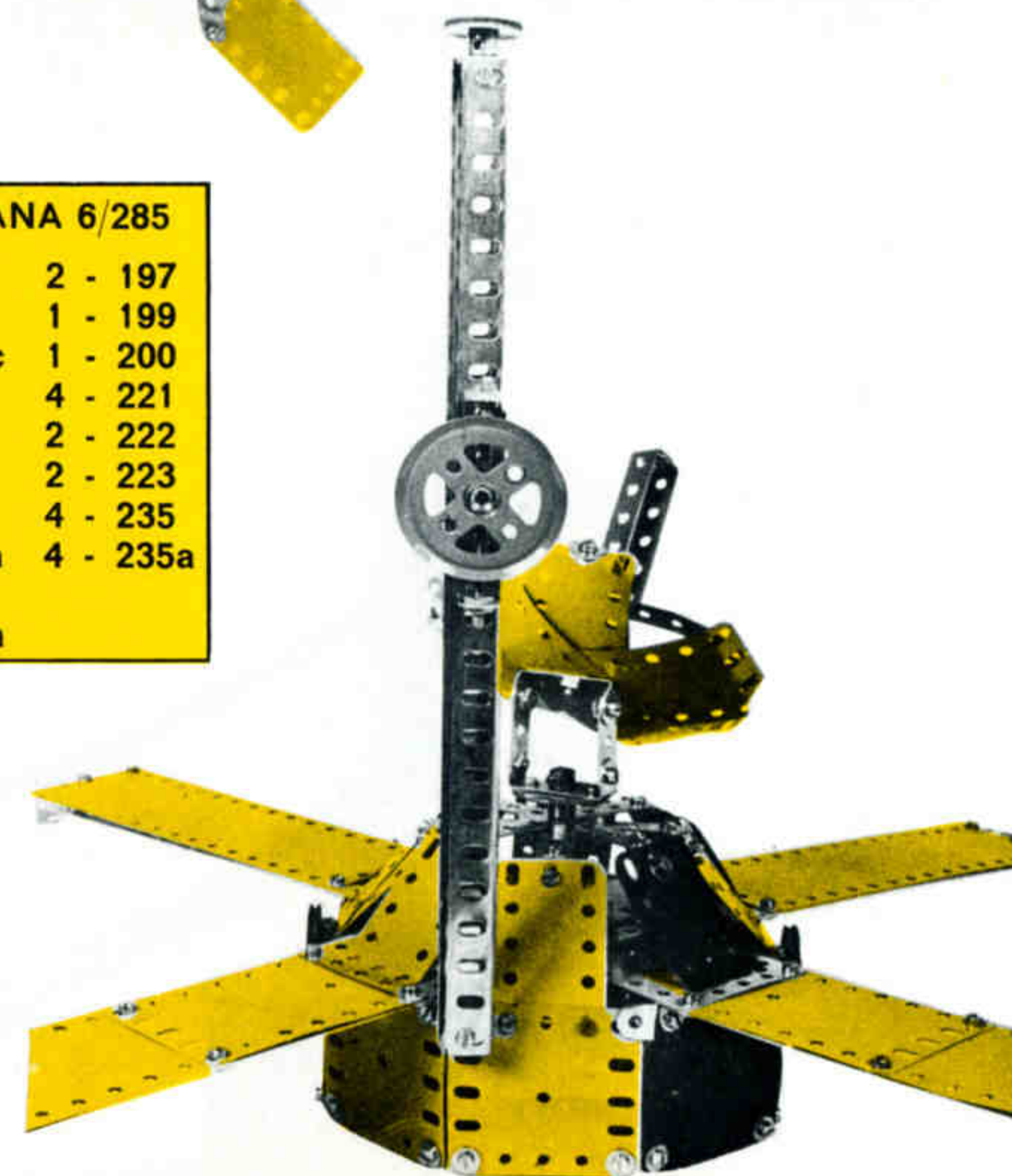
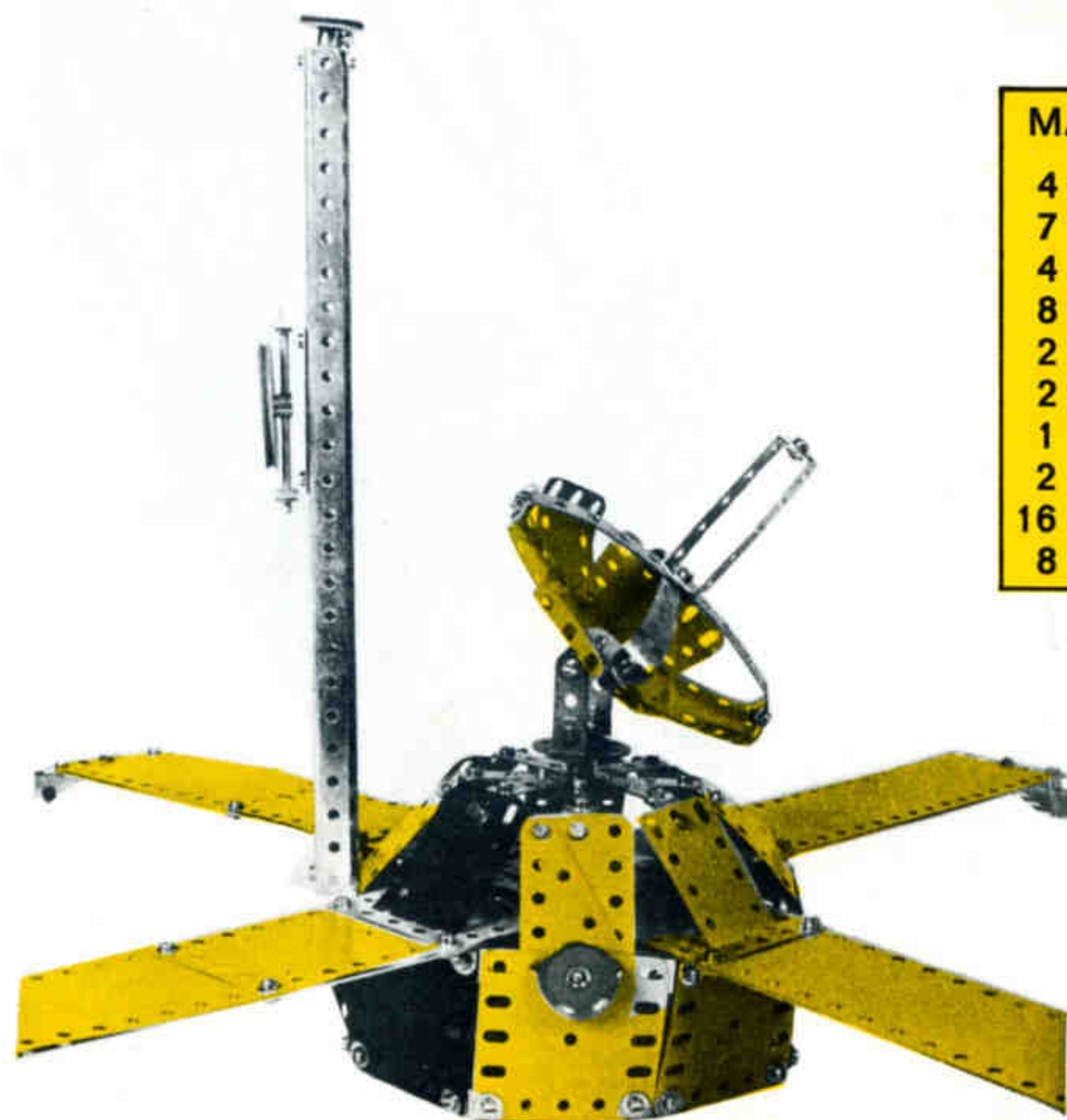

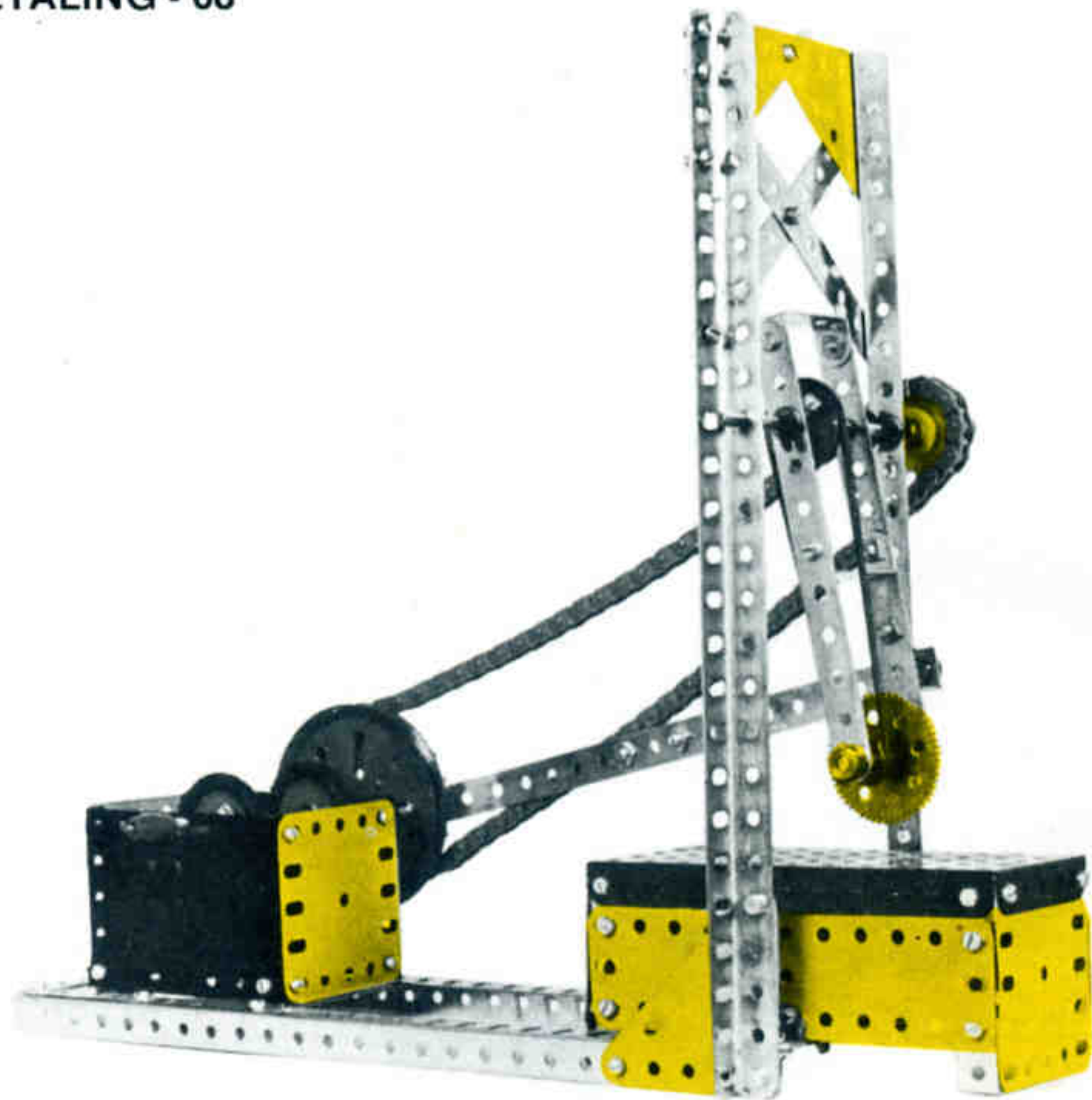

SIERRA CIRCULAR MOVIL		
6/286		
6 - 2	2 - 35	1 - 92
4 - 3	79 - 37a	1 - 111
4 - 8	74 - 37b	2 - 142c
2 - 12	5 - 38	1 - 186b
1 - 15	1 - 45	2 - 189
1 - 17	2 - 48	4 - 190
1 - 19b	6 - 48a	4 - 221
1 - 19g	1 - 52	2 - 222
3 - 22	2 - 53	2 - 223
1 - 23a	1 - 59	69 - 374
1 - 27a	1 - 91	

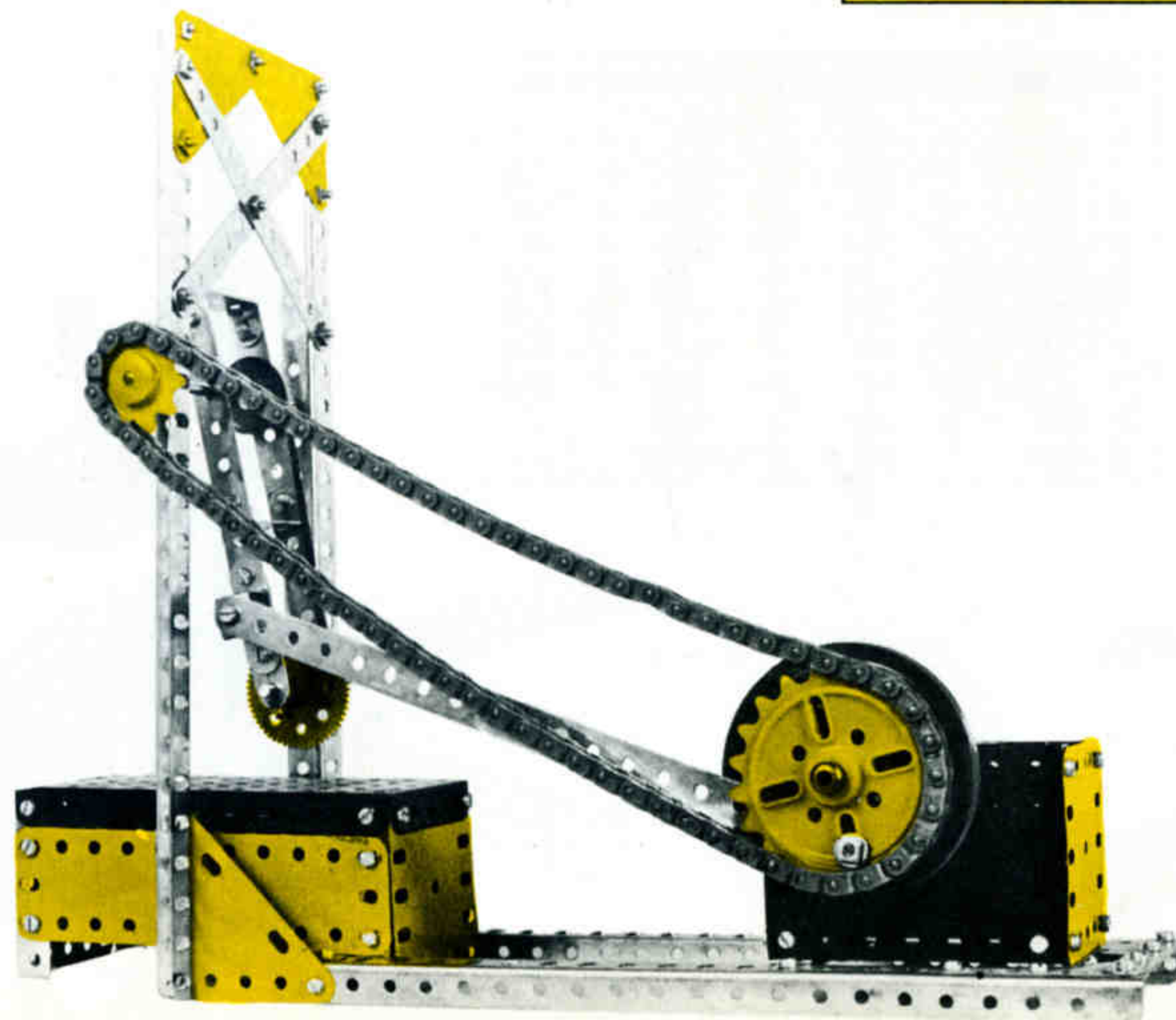

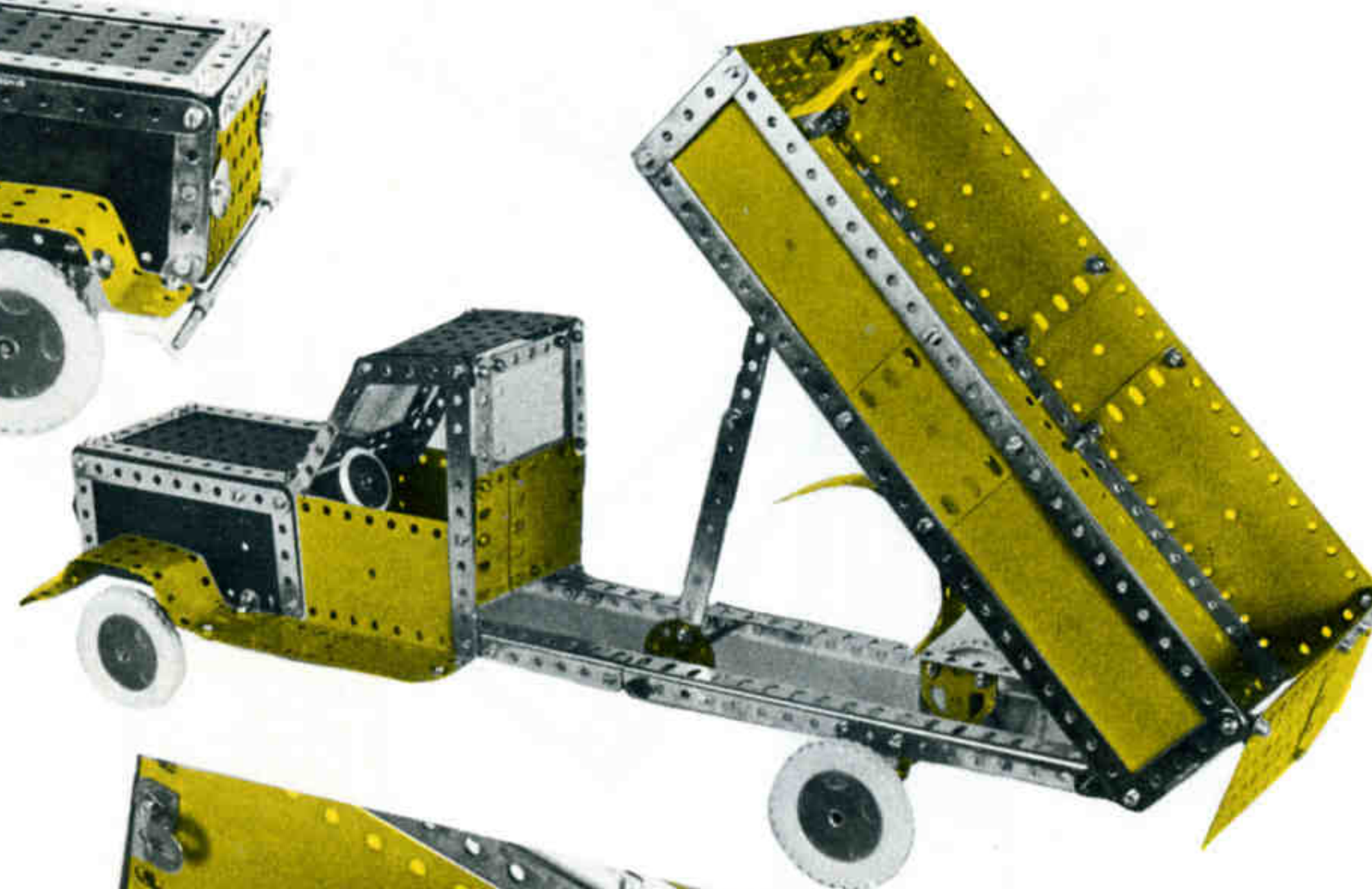
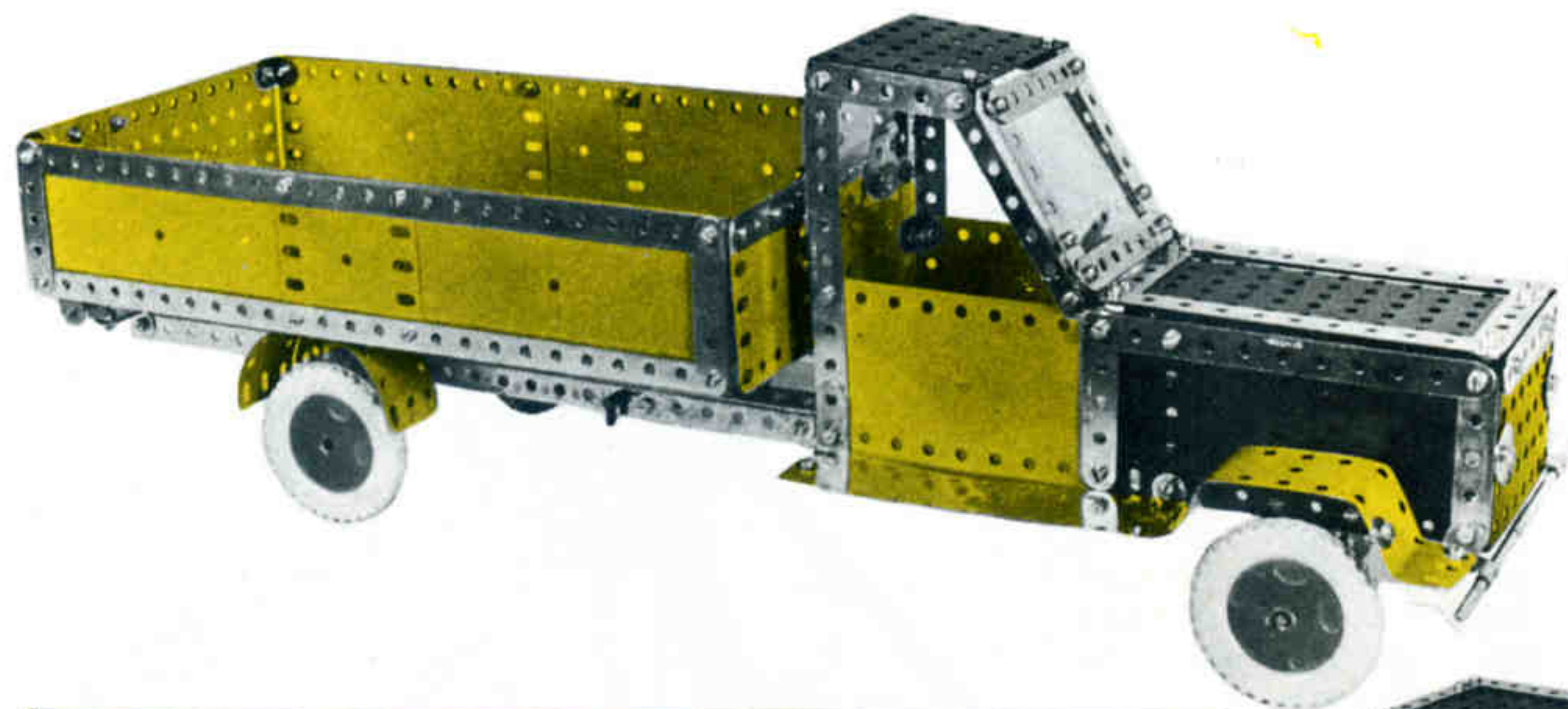

**CAMION VOLQUETE 6/287**

7 - 1	16 - 12	1 - 22	2 - 48b	1 - 155	2 - 194
14 - 2	2 - 12a	1 - 24	1 - 52	4 - 187	2 - 194c
4 - 3	4 - 12c	1 - 11a	2 - 53	4 - 189	2 - 197
2 - 4	2 - 15	2 - 35	2 - 53a	4 - 188	2 - 212a
14 - 5	1 - 15a	134 - 37a	4 - 59	6 - 190	2 - 213
2 - 6a	2 - 16	130 - 37b	4 - 111c	2 - 191	1 - 235a
4 - 8	1 - 15b	2 - 38	2 - 125	4 - 192	2 - 235b
2 - 10	1 - 17	2 - 38d	4 - 126a	1 - 193a	
3 - 11	1 - 18a	2 - 48a	1 - 147b	1 - 193c	

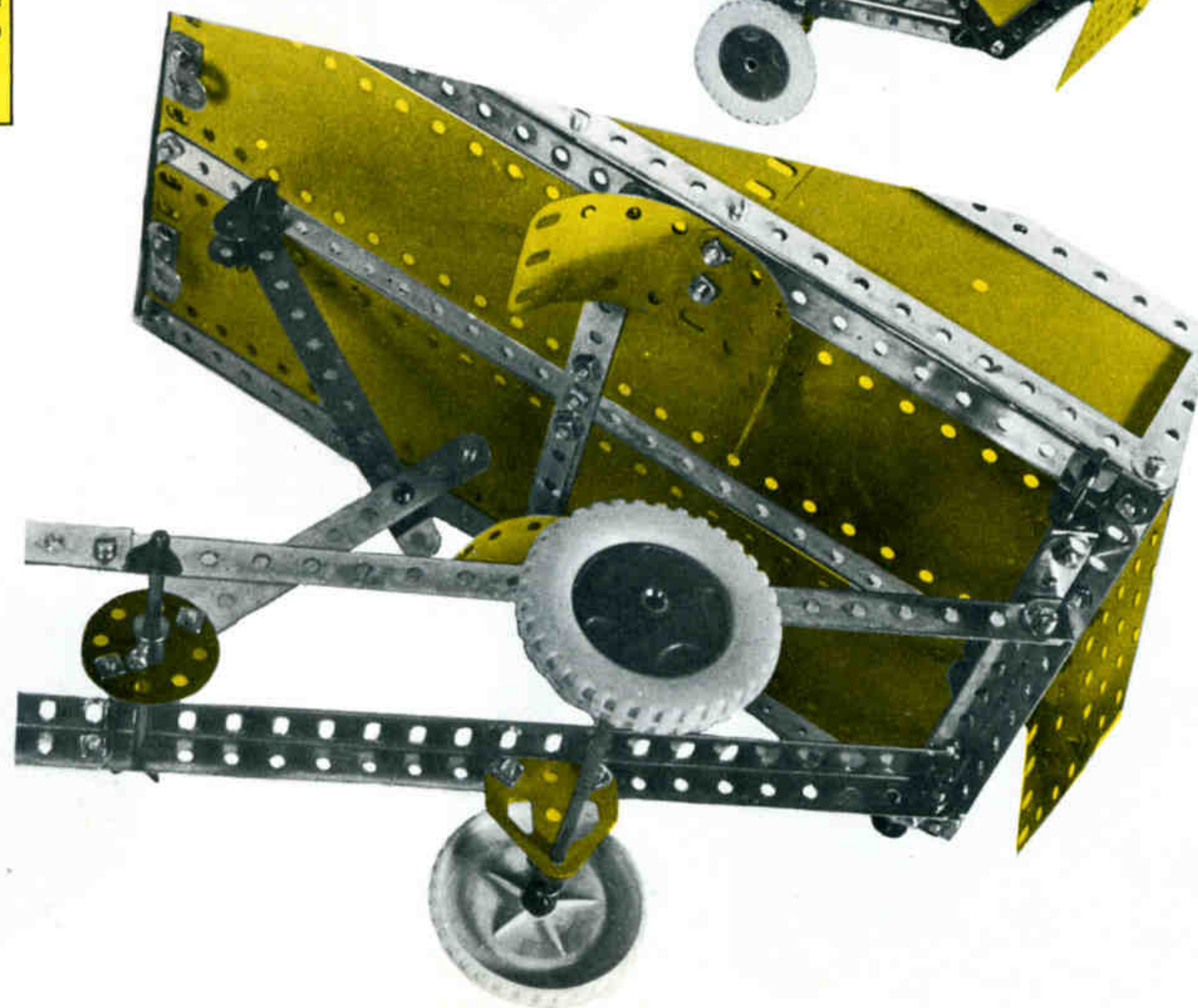
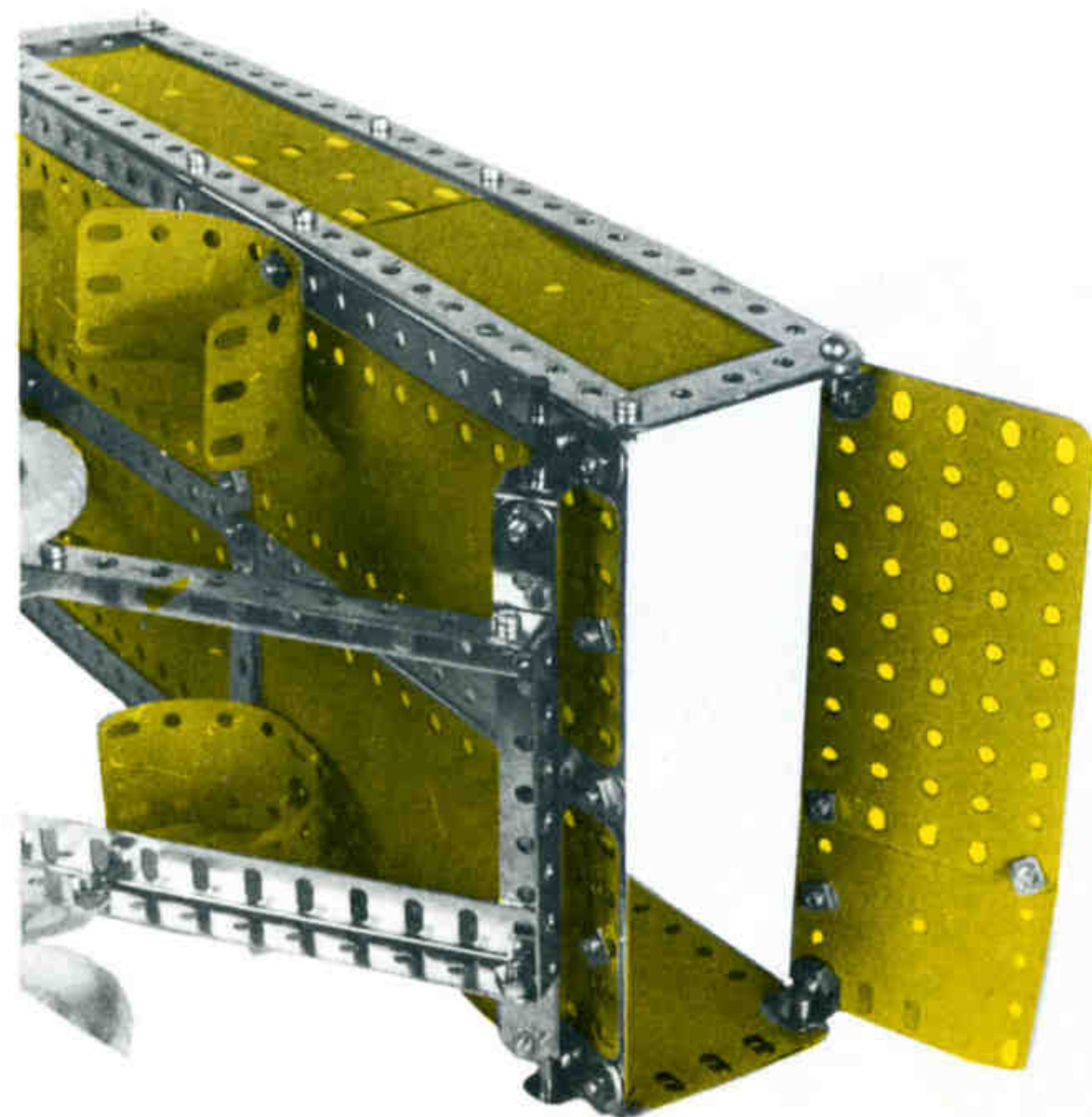



**MOLINO DE VIENTO 6/288**

12 - 1	1 - 27a	4 - 90
10 - 2	4 - 35	1 - 91
2 - 3	92 - 37a	1 - 92
2 - 5	92 - 37b	4 - 126a
4 - 8	8 - 38	4 - 189
1 - 15	1 - 40	6 - 190
1 - 16	2 - 48a	2 - 191
1 - 19h	1 - 52	2 - 192
2 - 22	2 - 53	69 - 374
1 - 24	2 - 53a	
1 - 26	2 - 54	



**SPORT DESCAPOTABLE 6/289**

14 - 2	10 - 38	2 - 191
4 - 3	2 - 38d	4 - 192
7 - 5	2 - 48	1 - 193a
2 - 6a	1 - 51	1 - 193e
4 - 8	2 - 53a	2 - 194
5 - 10	4 - 59	2 - 194a
3 - 11	4 - 90a	2 - 197
16 - 12	2 - 111	1 - 199
2 - 12a	2 - 111a	1 - 200
5 - 12c	3 - 111c	4 - 215
1 - 14	4 - 125	2 - 221
1 - 15	2 - 126	2 - 222
2 - 18a	2 - 126a	4 - 235a
2 - 24	4 - 187	1 - 235
2 - 35	3 - 188	2 - 235b
154 - 37a	4 - 189	
110 - 37b	6 - 190	

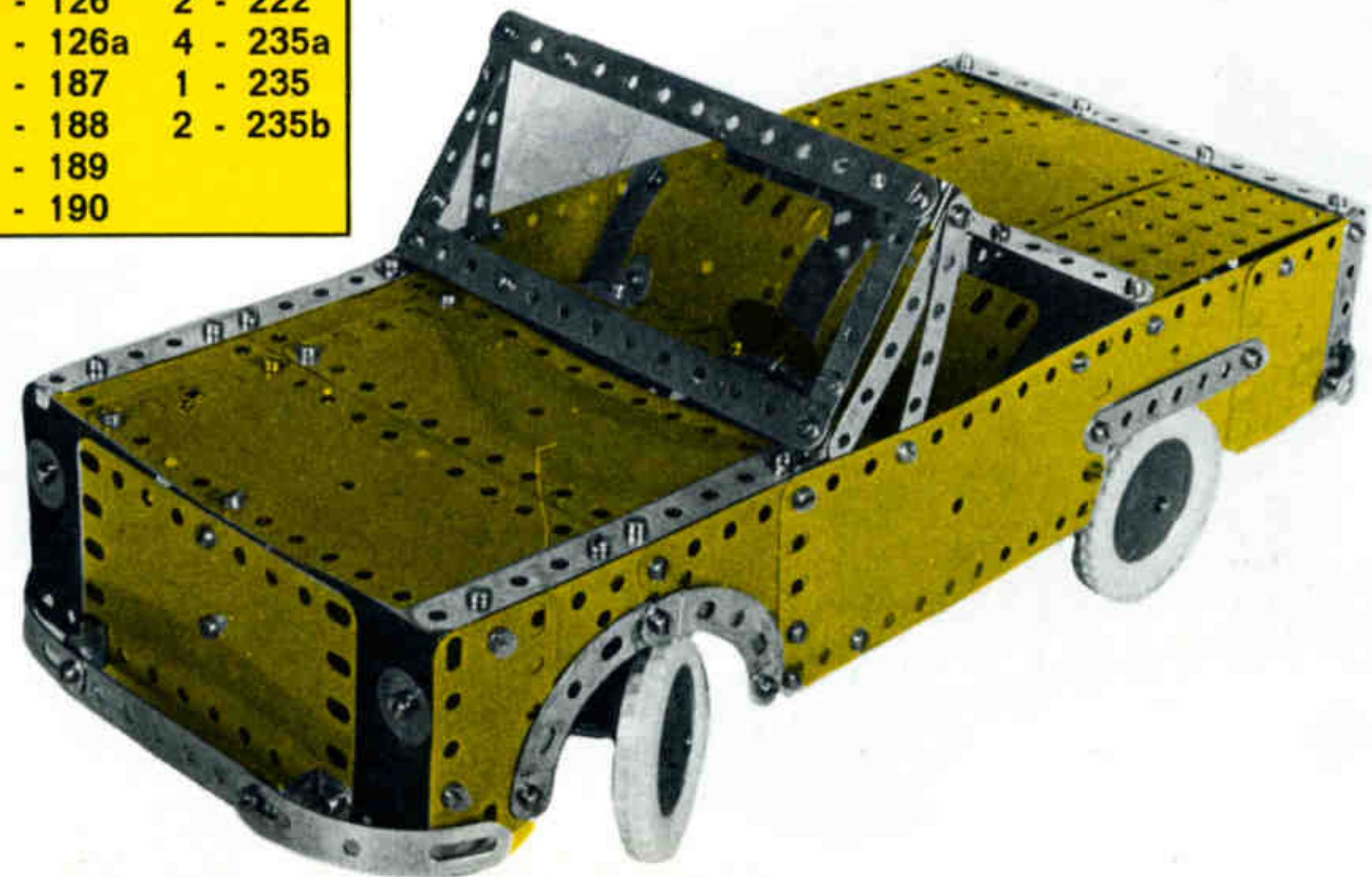
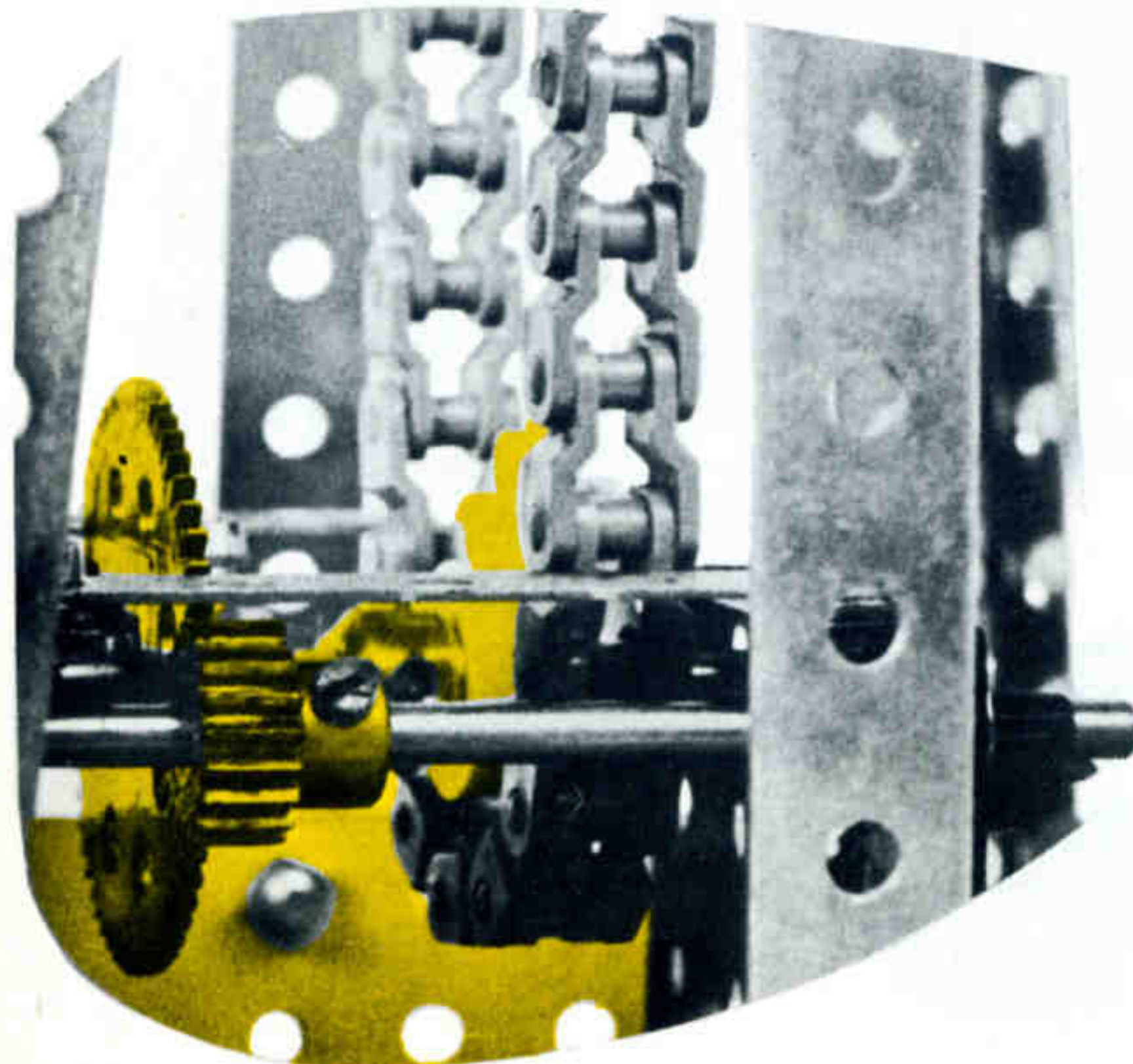



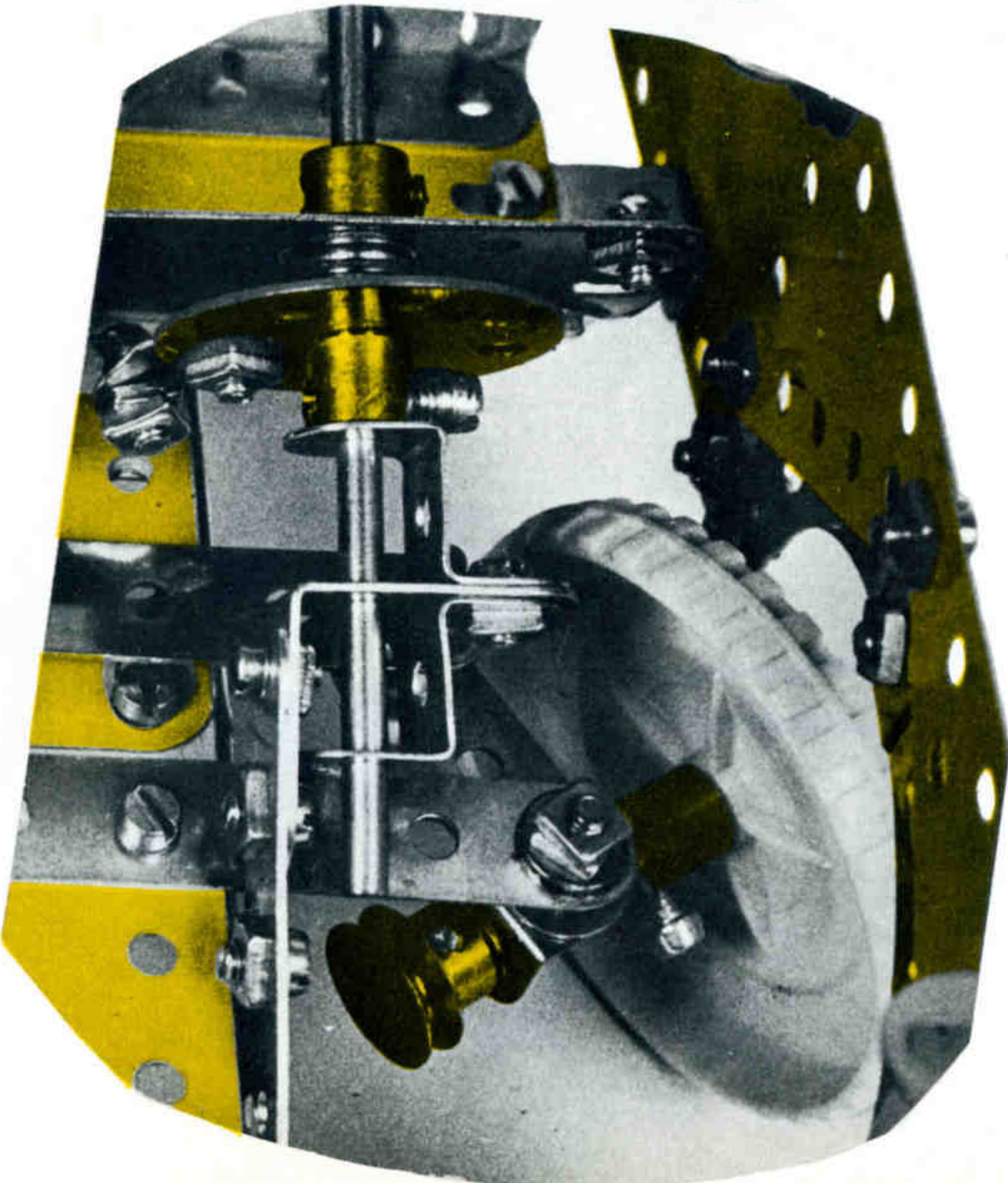
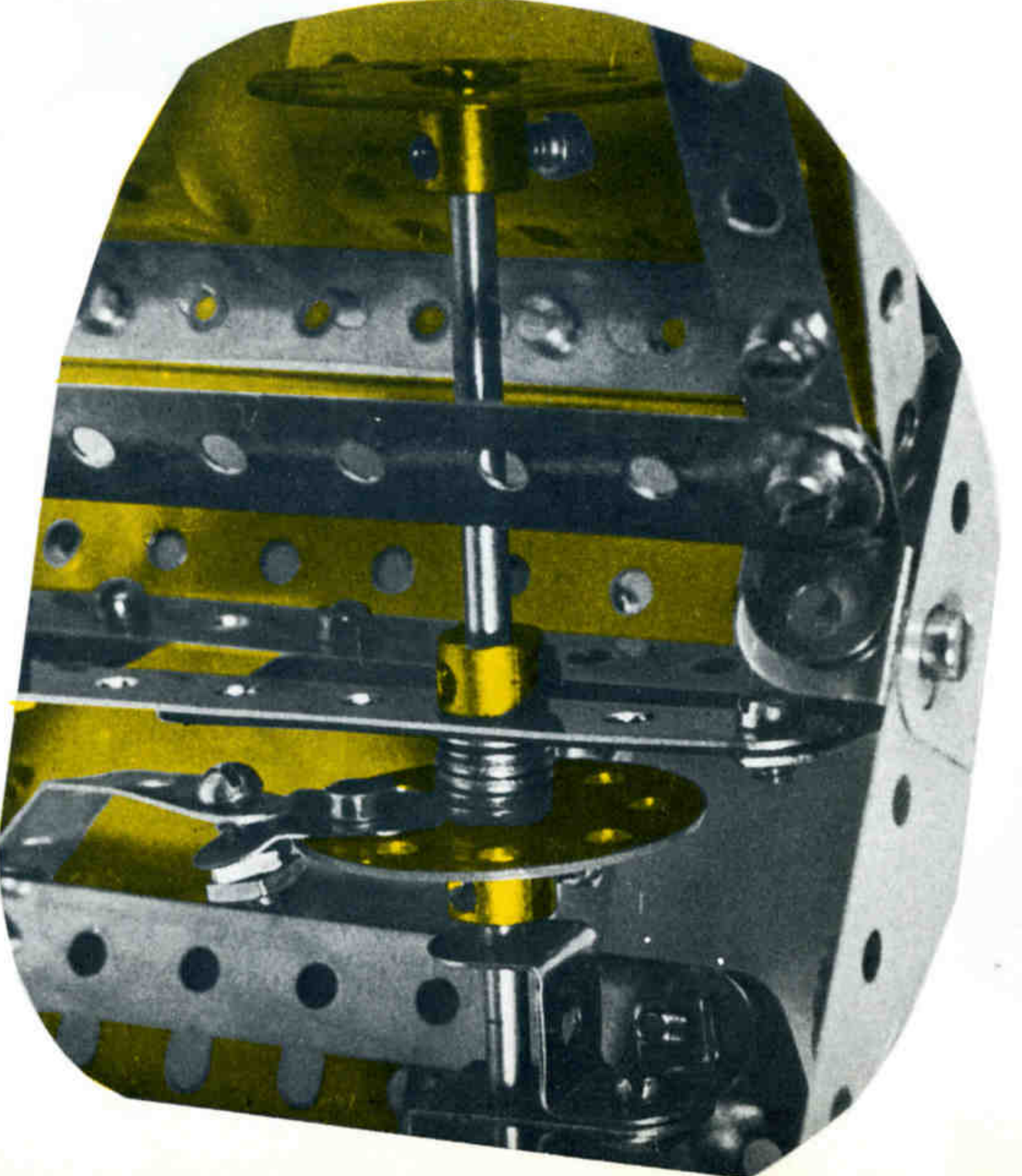
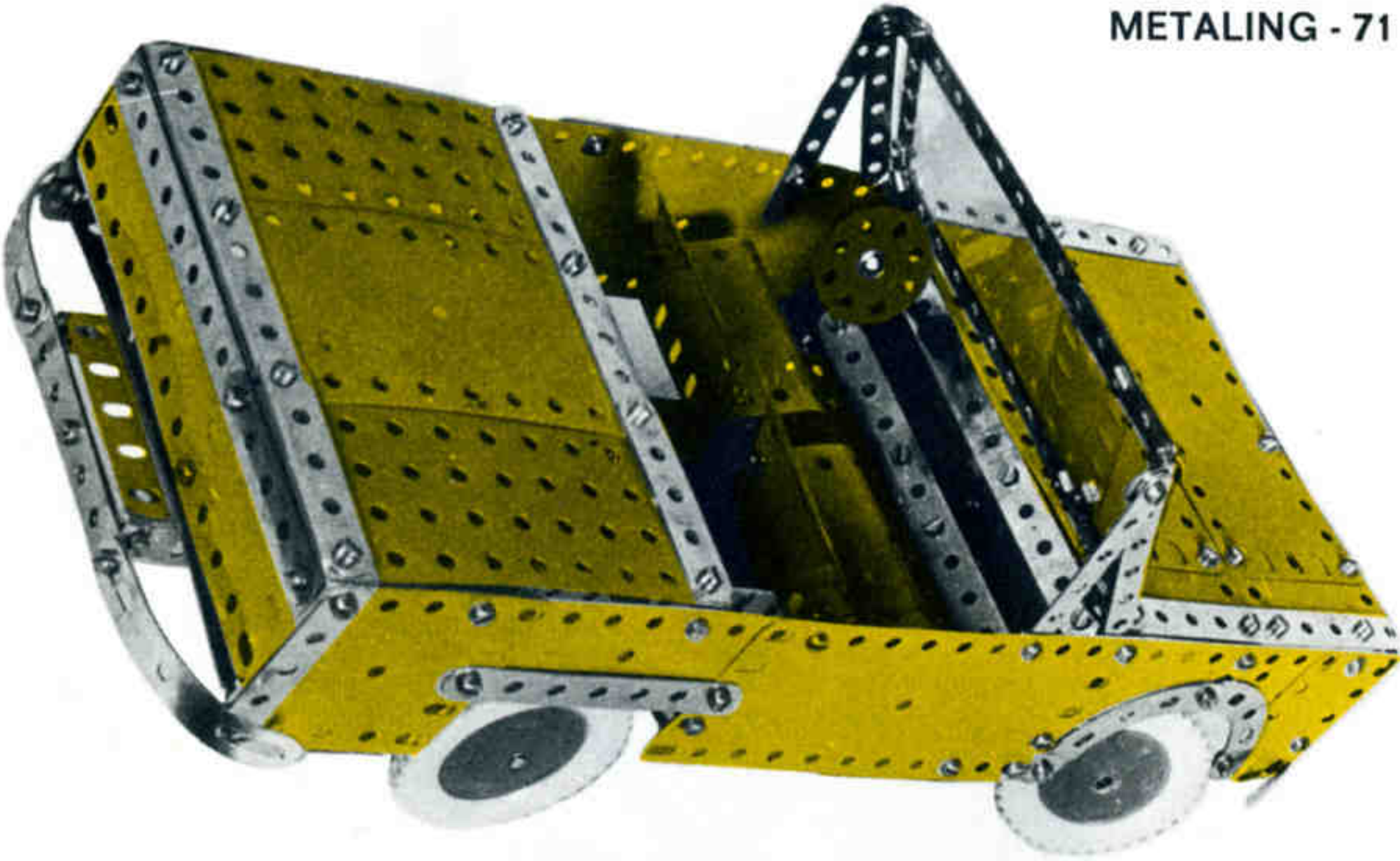
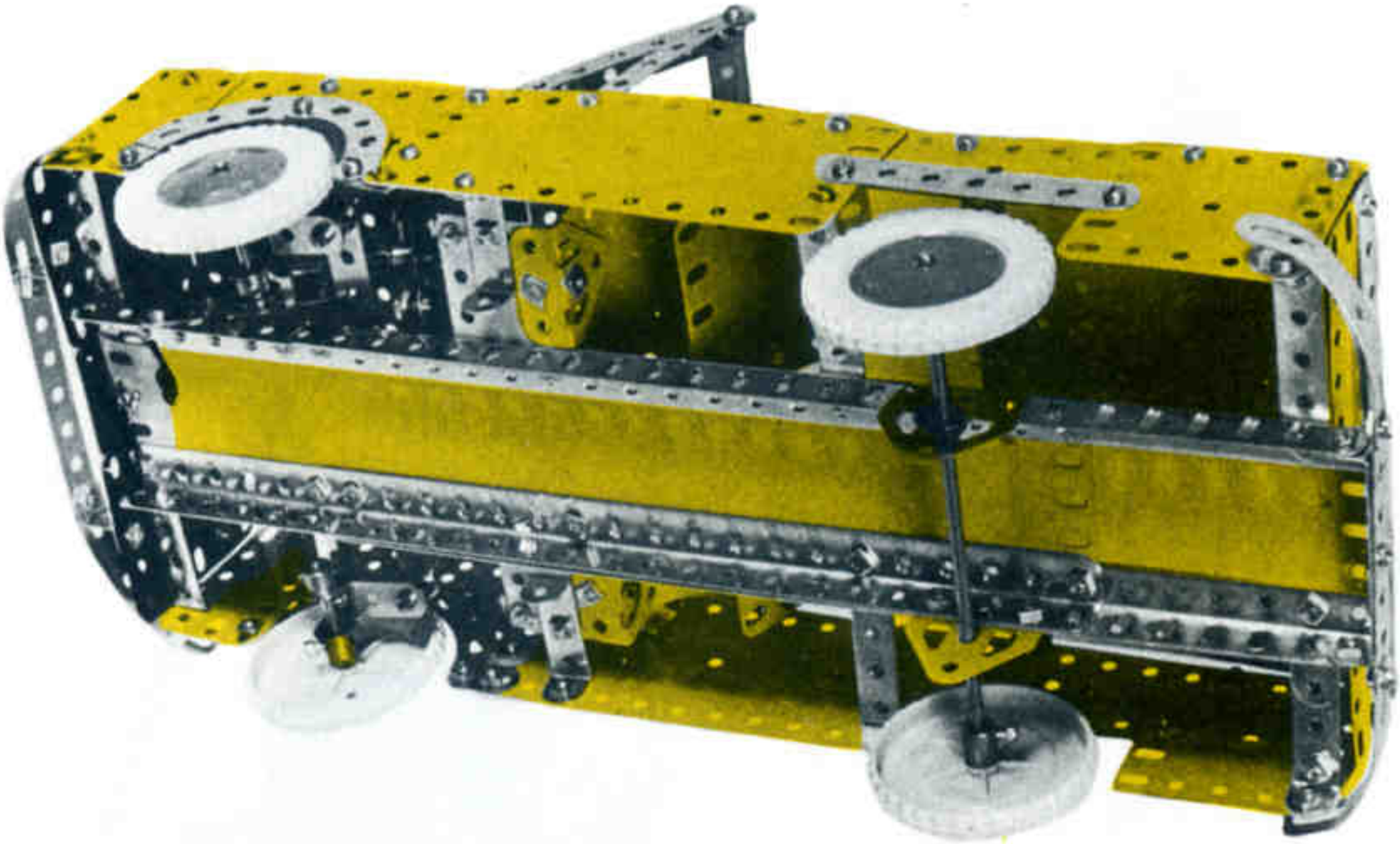

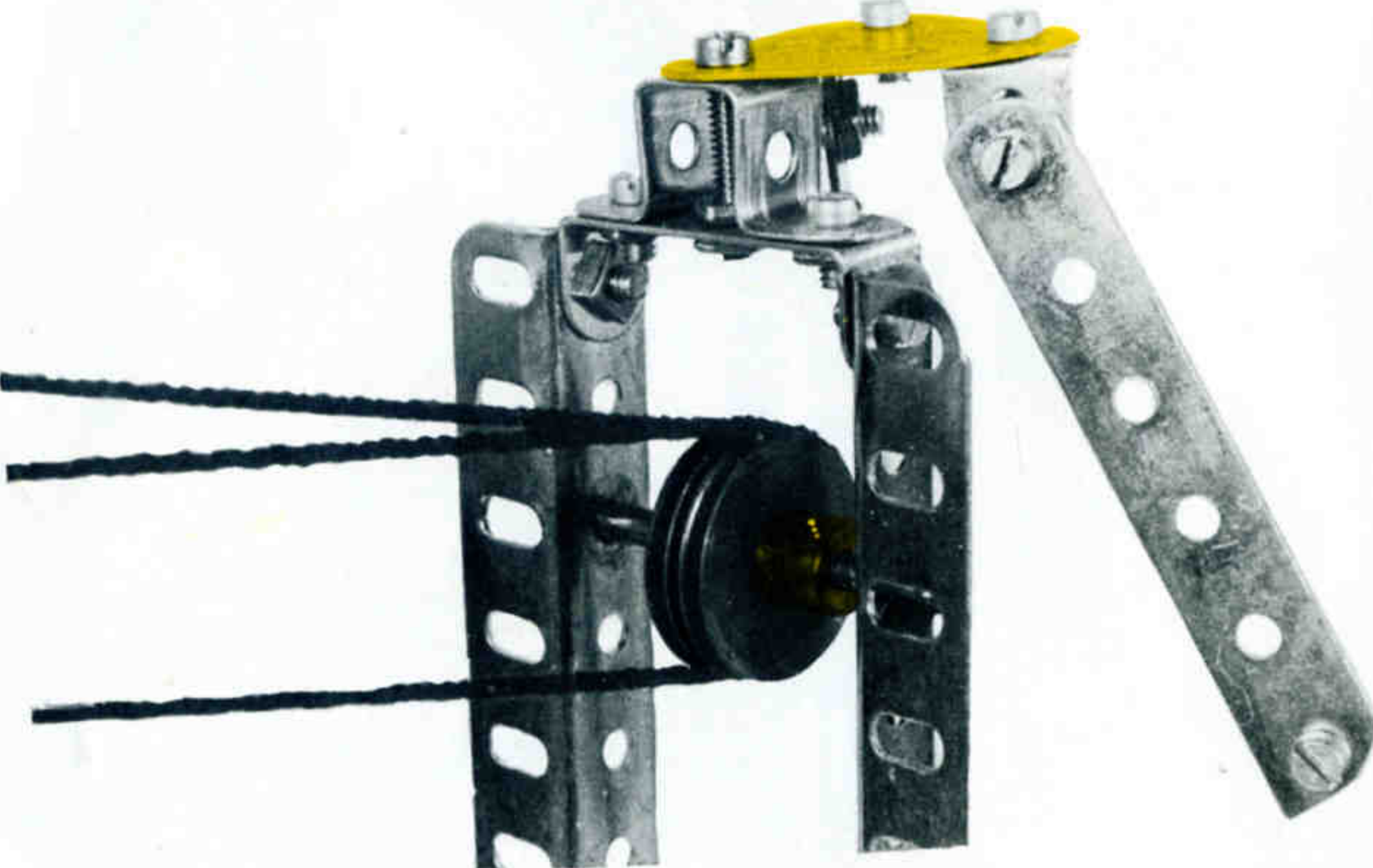
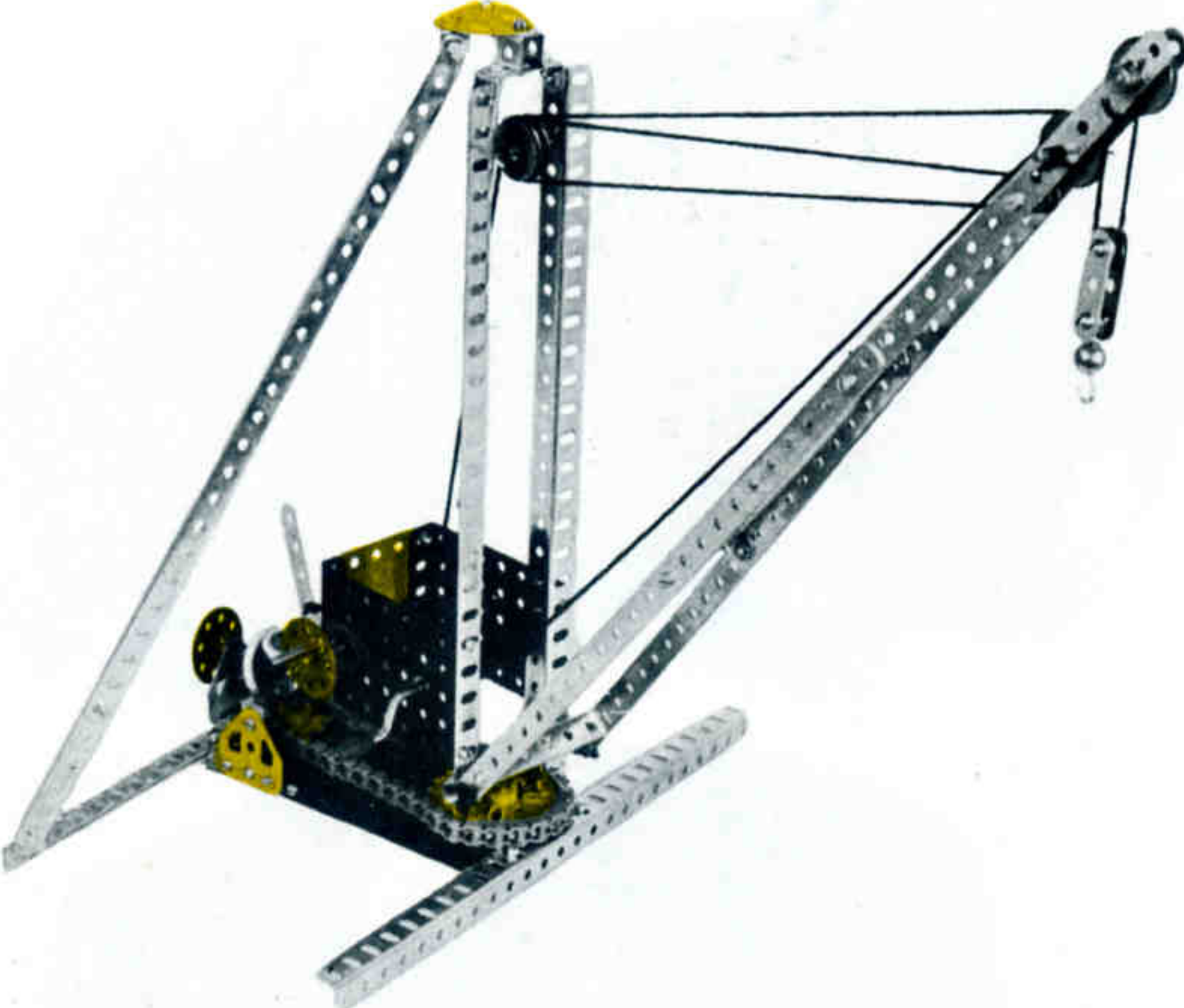

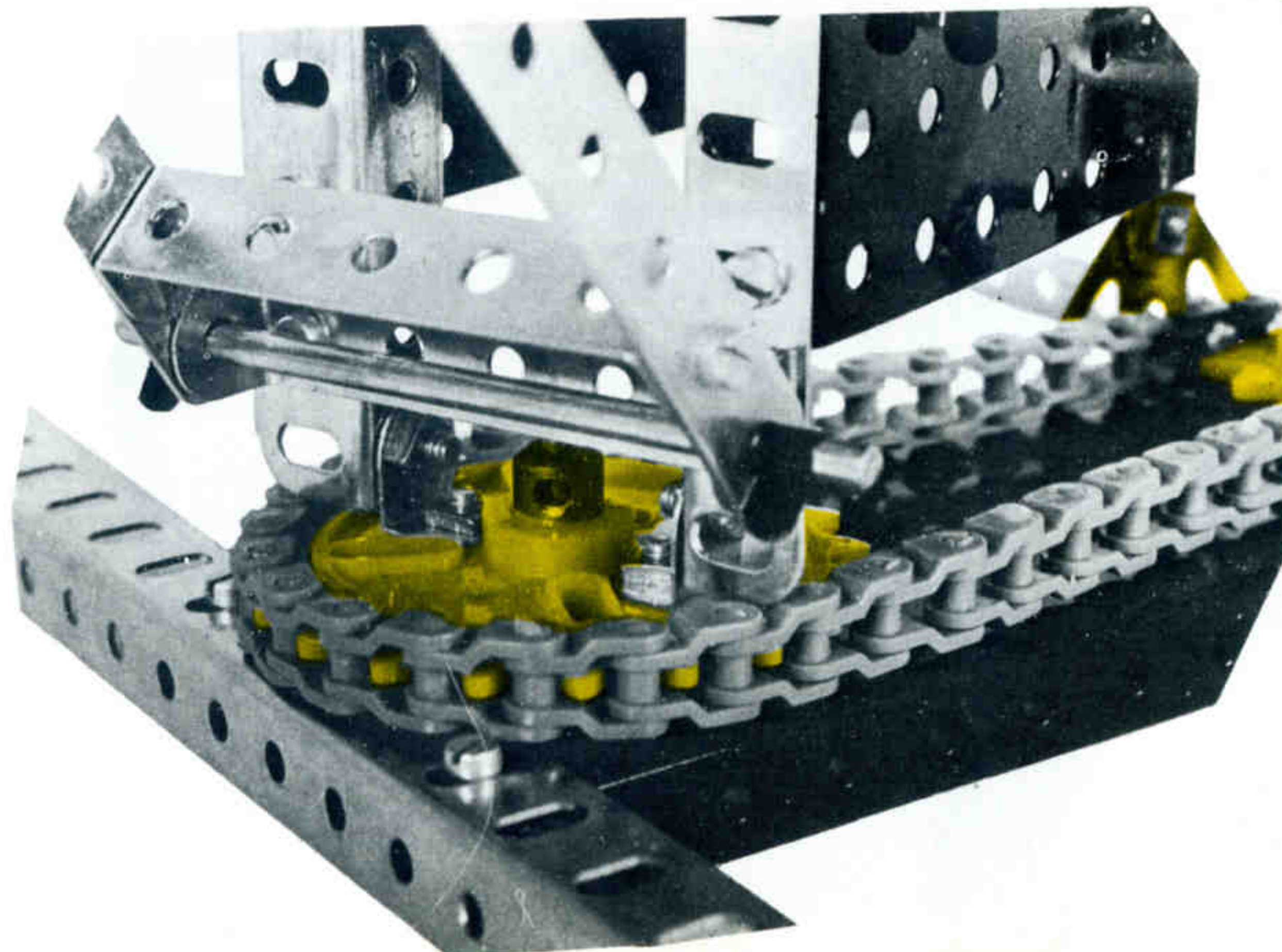
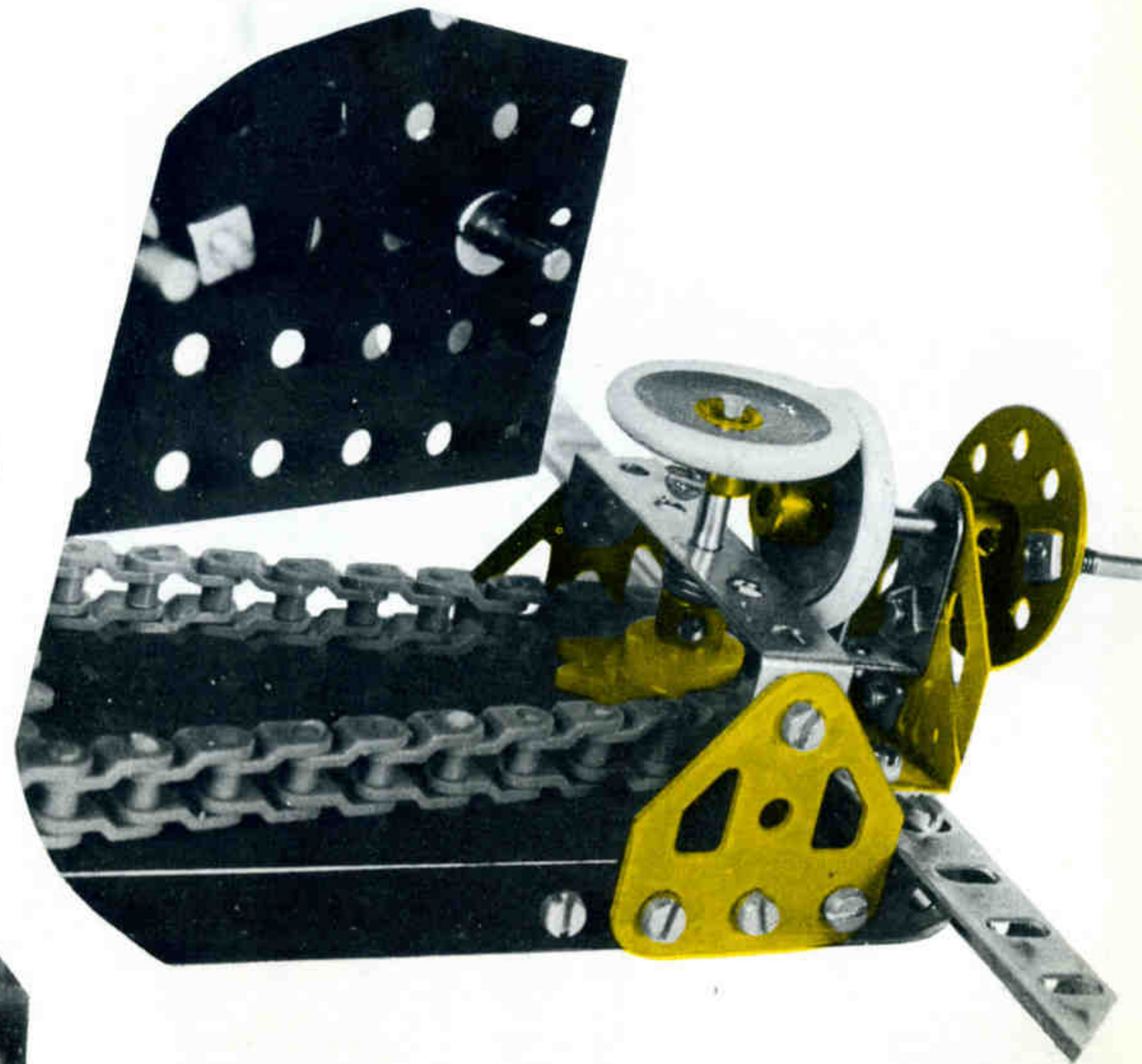
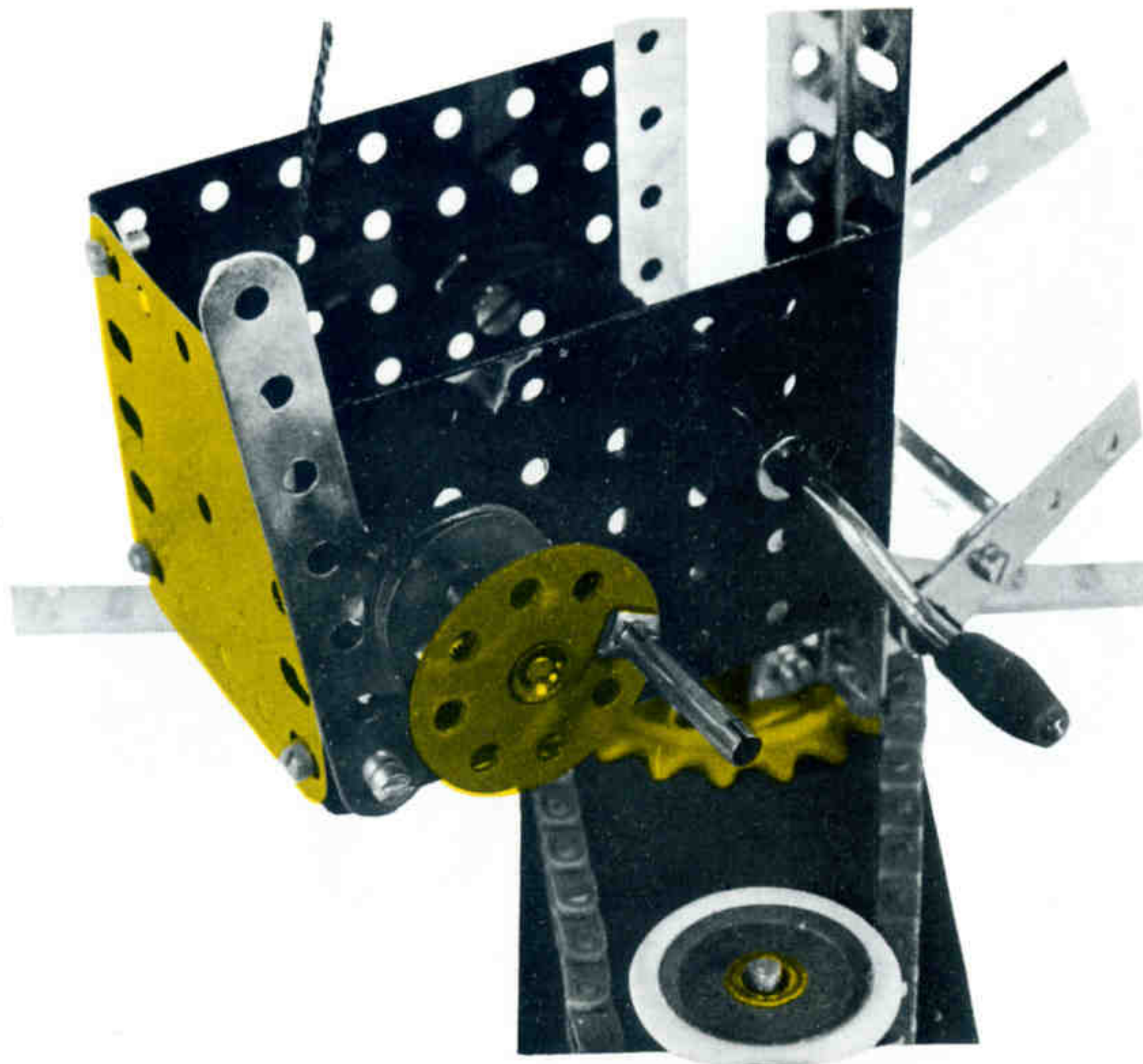

**GRUA GIRATORIA 6/290**

8 - 1	1 - 16	10 - 35	2 - 53	1 - 147b
2 - 2	2 - 17	71 - 37a	1 - 57c	2 - 155
1 - 3	3 - 18a	62 - 37b	2 - 59	1 - 176
2 - 5	1 - 18b	12 - 38	1 - 91	1 - 186
1 - 6a	1 - 19g	1 - 38d	1 - 92	1 - 190
4 - 8	5 - 22	1 - 45	2 - 111	1 - 213
1 - 11	2 - 22a	1 - 48	2 - 111c	39 - 374
1 - 11a	1 - 23	3 - 48a	1 - 115	
10 - 12	1 - 23a	1 - 51	1 - 126	
1 - 15b	2 - 24	1 - 52	4 - 126a	

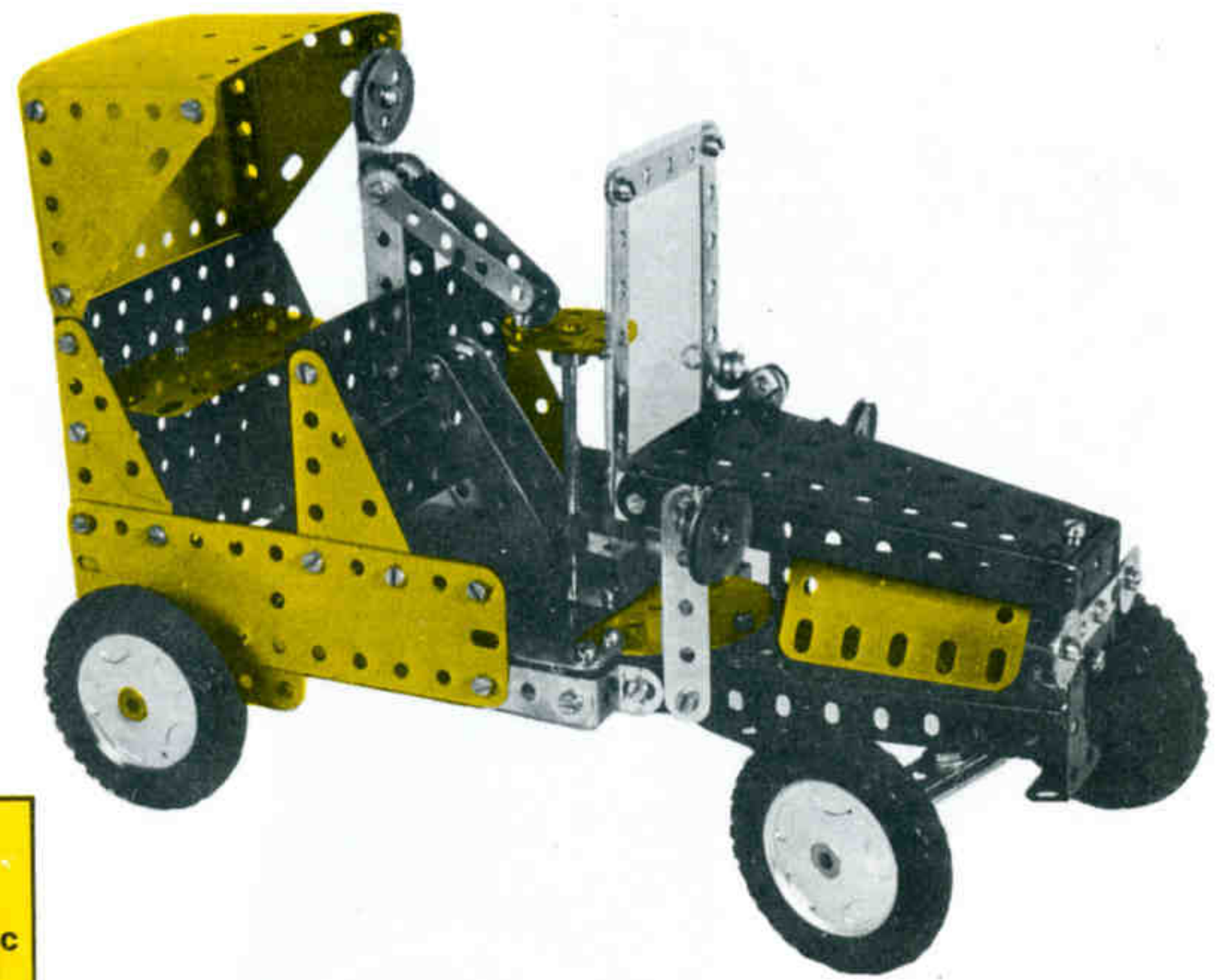
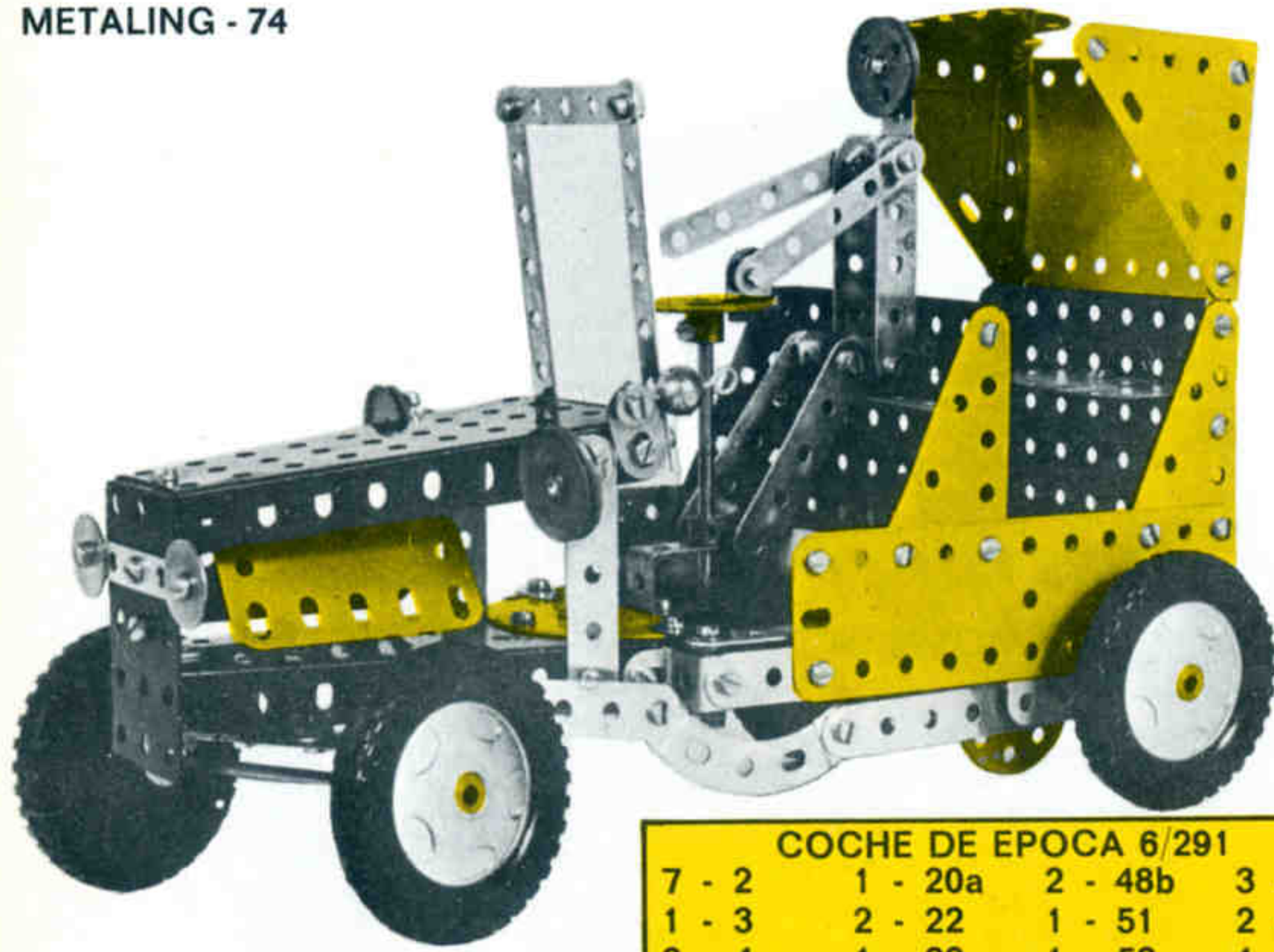

**COCHE DE EPOCA 6/291**

7 - 2	1 - 20a	2 - 48b	3 - 189
1 - 3	2 - 22	1 - 51	2 - 191
2 - 4	1 - 22a	1 - 52	1 - 193c
6 - 5	2 - 24	2 - 53	1 - 199
1 - 6a	1 - 26	2 - 54	1 - 214
6 - 10	1 - 27a	1 - 57c	4 - 221
4 - 11	3 - 35	3 - 59	2 - 223
1 - 11a	103 - 37a	1 - 90a	3 - 235
8 - 12	90 - 37b	2 - 111a	2 - 235a
1 - 12a	14 - 38	5 - 111c	2 - 125
1 - 15	2 - 38d	2 - 126a	2 - 235b
1 - 15a	1 - 45	4 - 187	
2 - 16	1 - 48a	2 - 188	

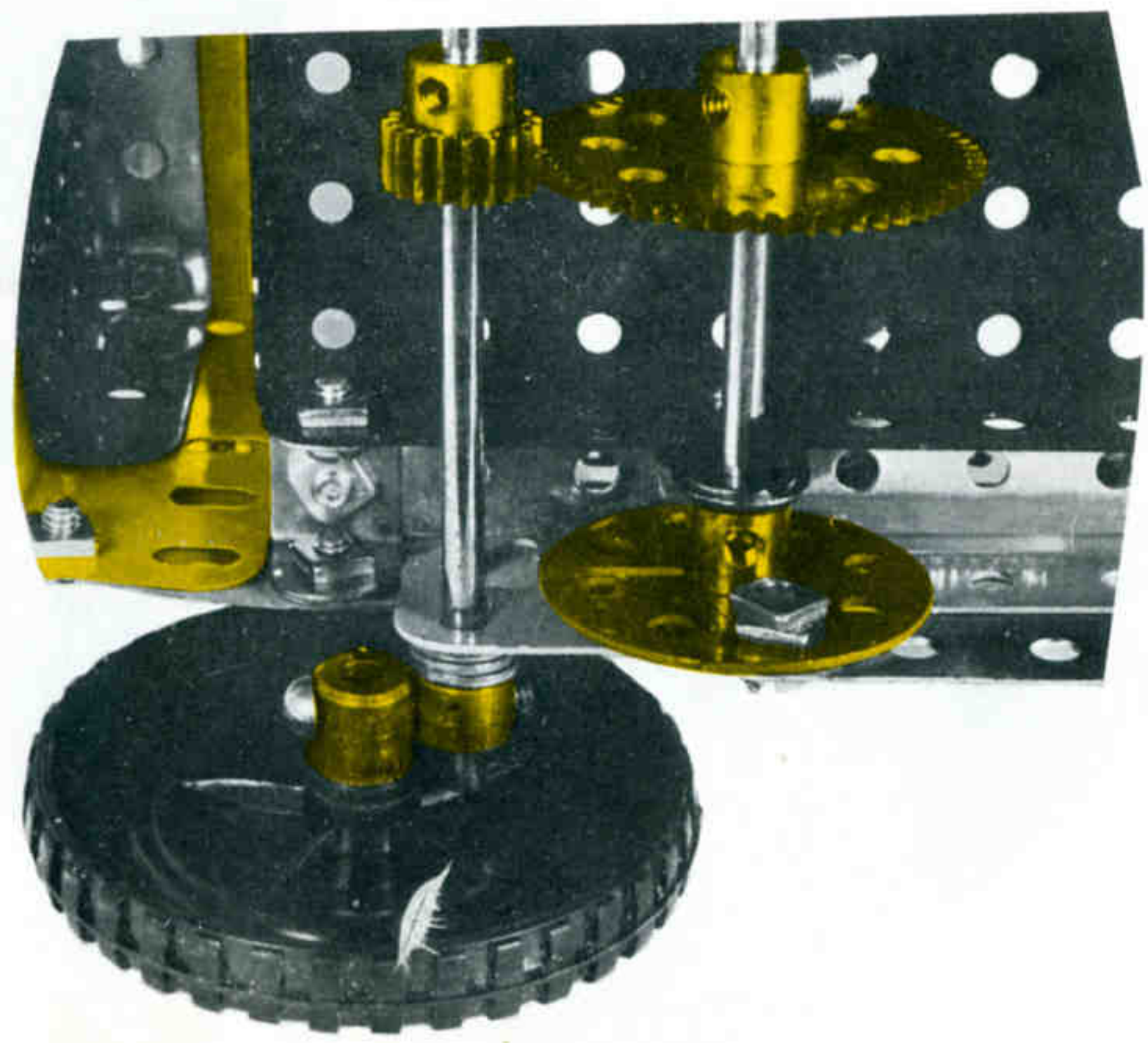
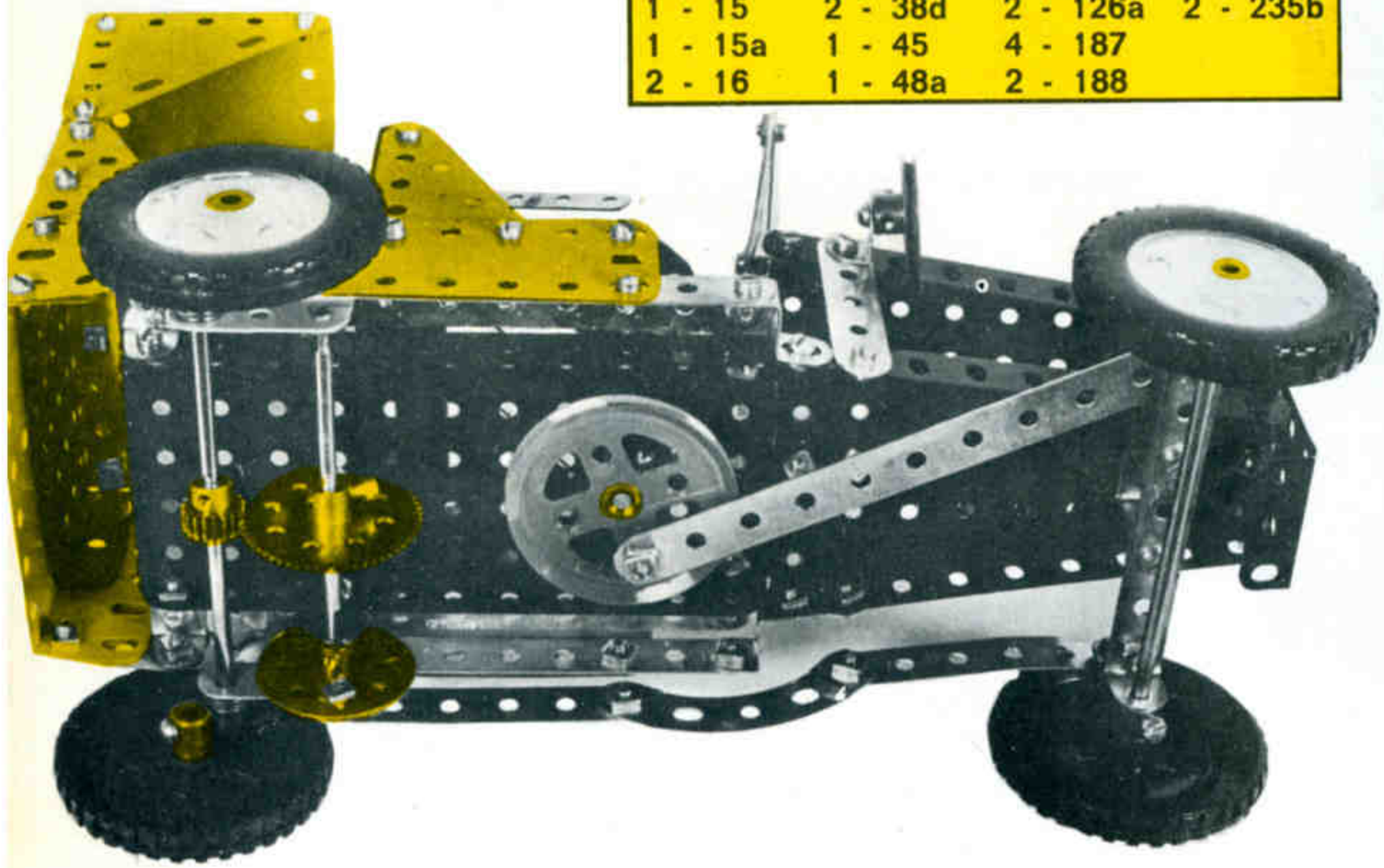

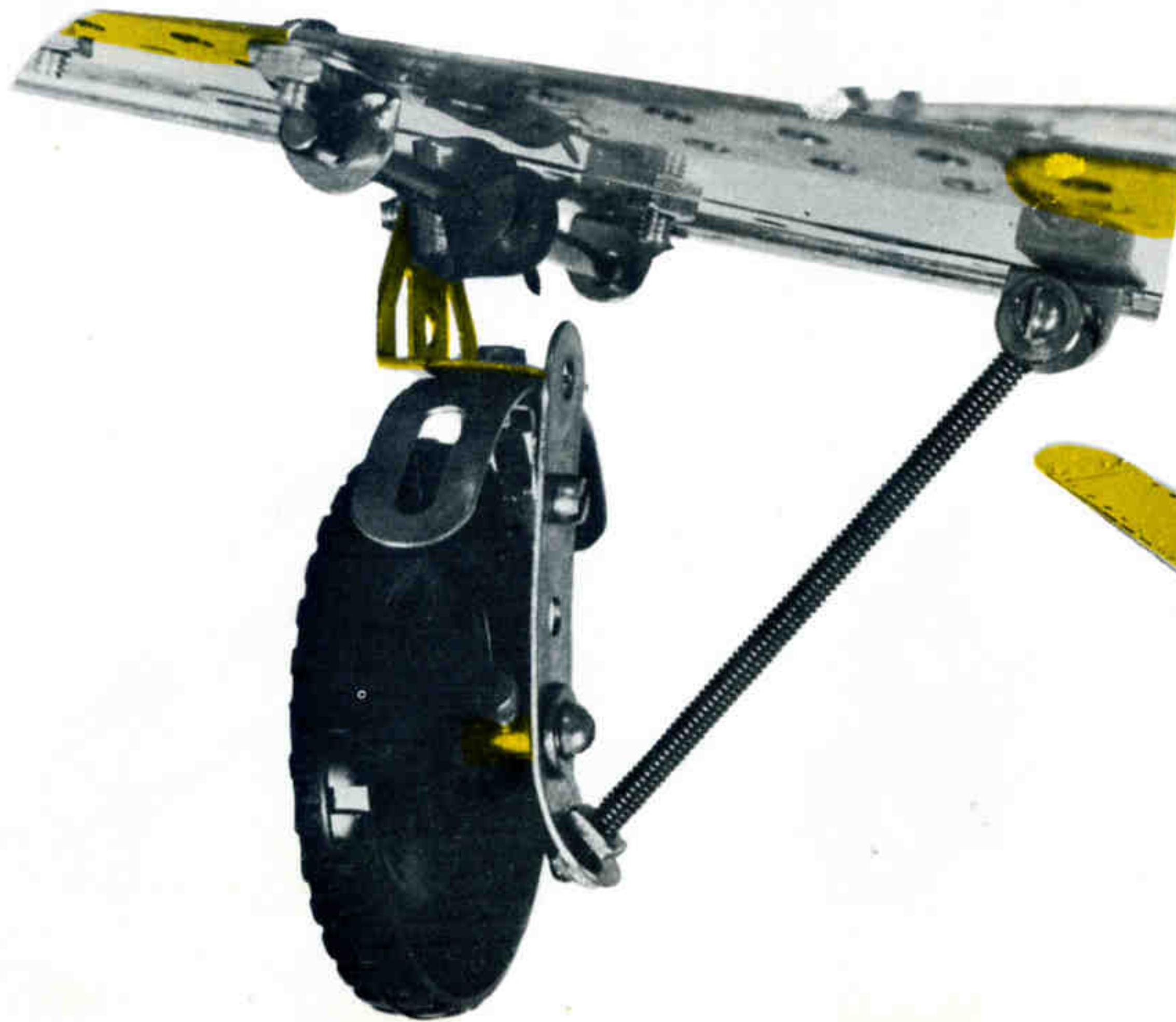
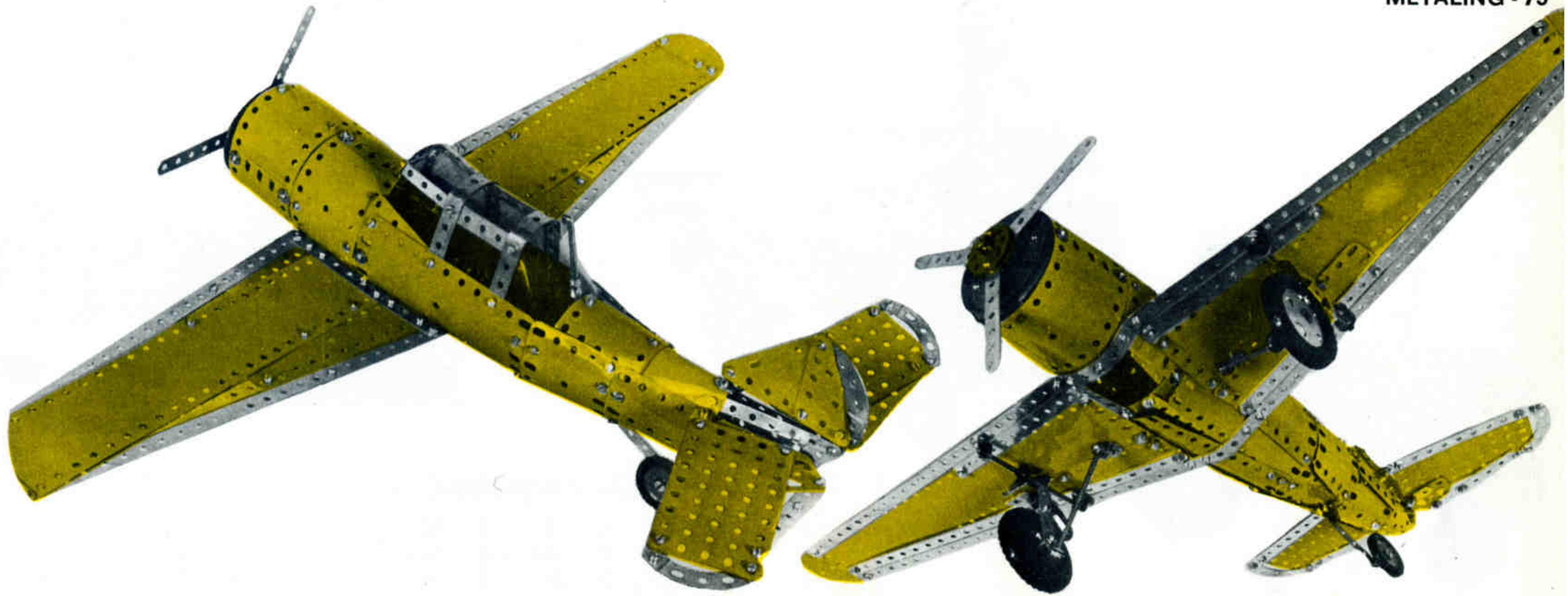

**MONOPLANO DE CAZA 6/292**

6 - 1	2 - 15b	24 - 38	1 - 142c	1 - 193d	2 - 222
14 - 2	2 - 17	2 - 53a	1 - 147b	1 - 193e	1 - 223
4 - 3	1 - 19b	2 - 59	2 - 187	2 - 197	4 - 235
2 - 4	1 - 22	2 - 80c	3 - 188	1 - 199	2 - 235a
8 - 5	1 - 23a	3 - 90a	4 - 189	1 - 200	2 - 235b
2 - 6a	1 - 24	2 - 111a	3 - 190	1 - 212	
4 - 10	1 - 24c	6 - 111c	2 - 191	1 - 212a	
2 - 11	8 - 35	1 - 115	4 - 192	2 - 214	
16 - 12	151 - 37a	2 - 126	2 - 193	4 - 215	
2 - 12c	139 - 37b	2 - 126a	1 - 193c	3 - 221	

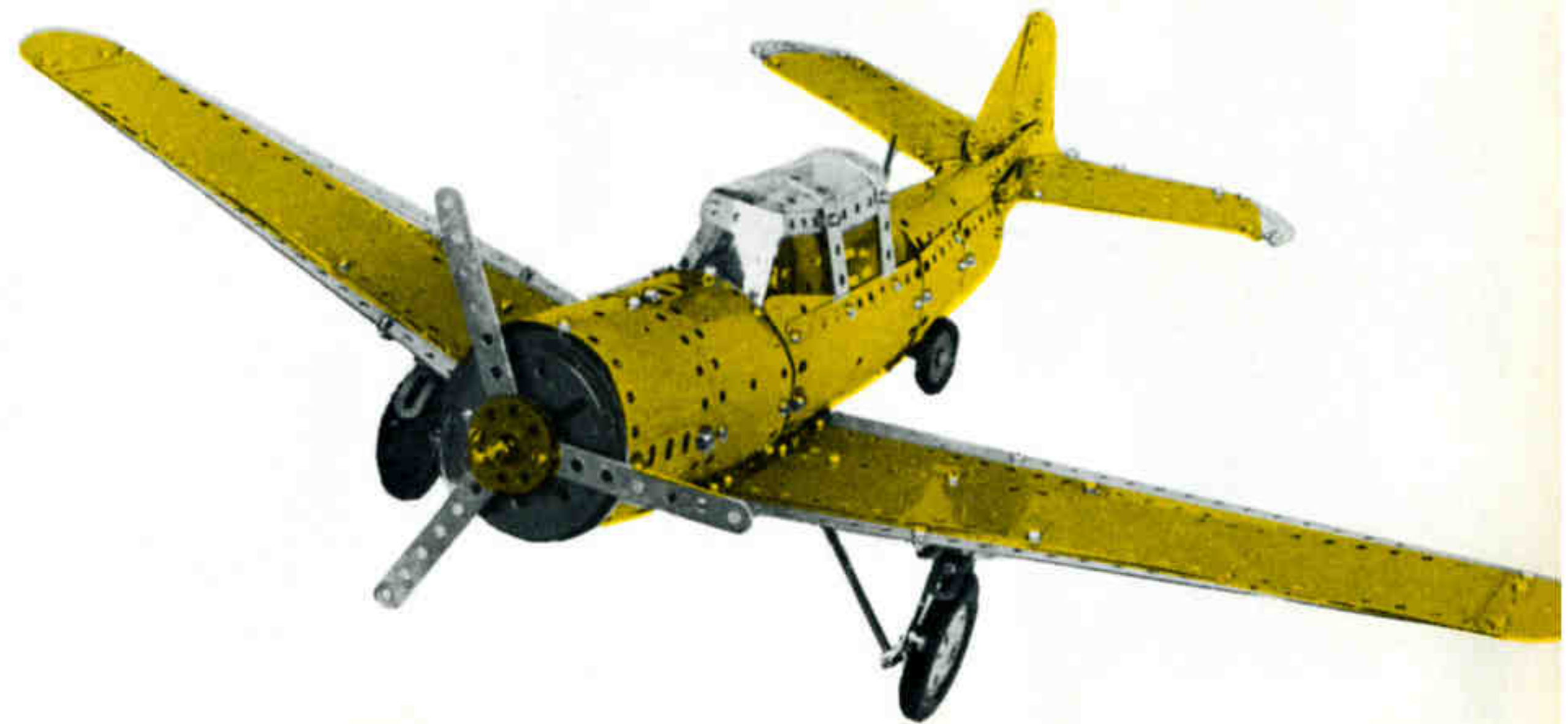

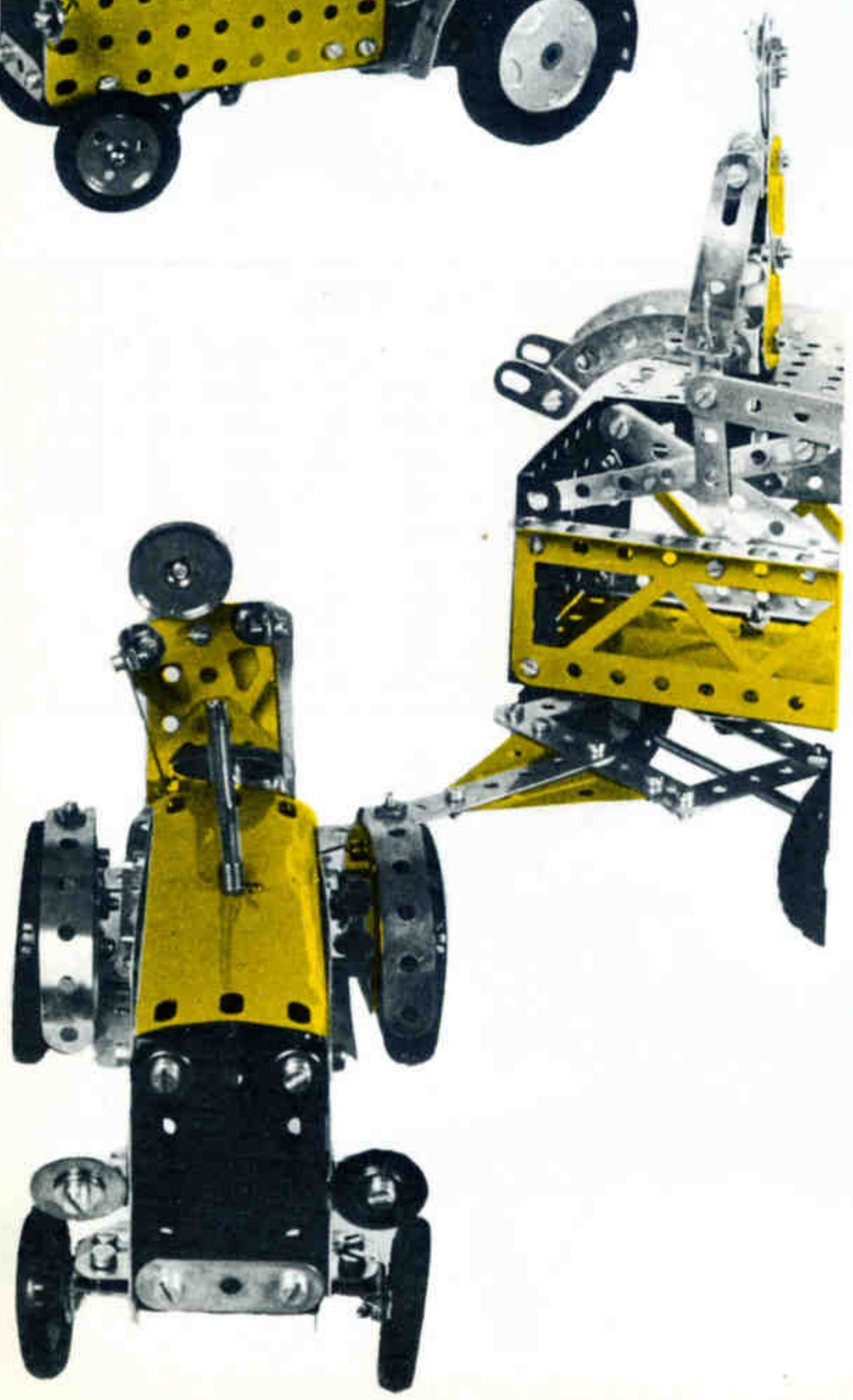
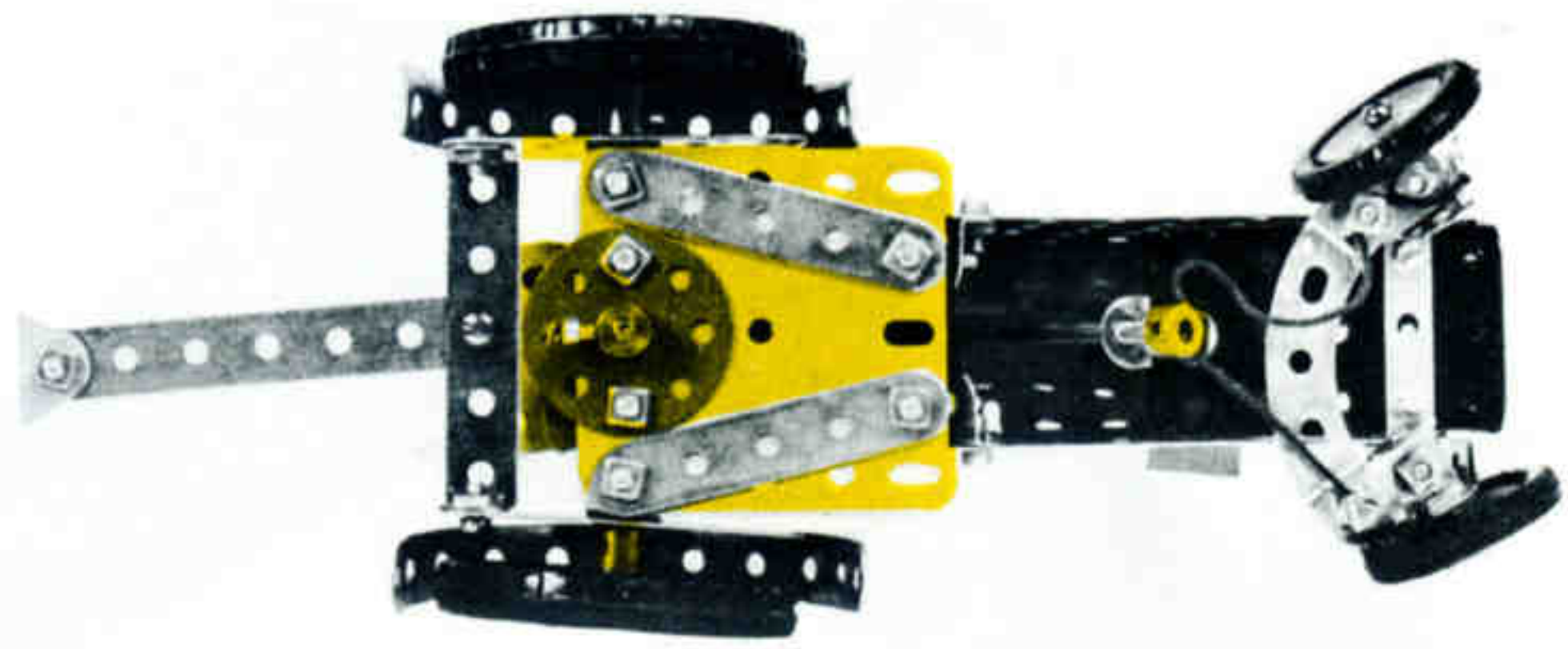
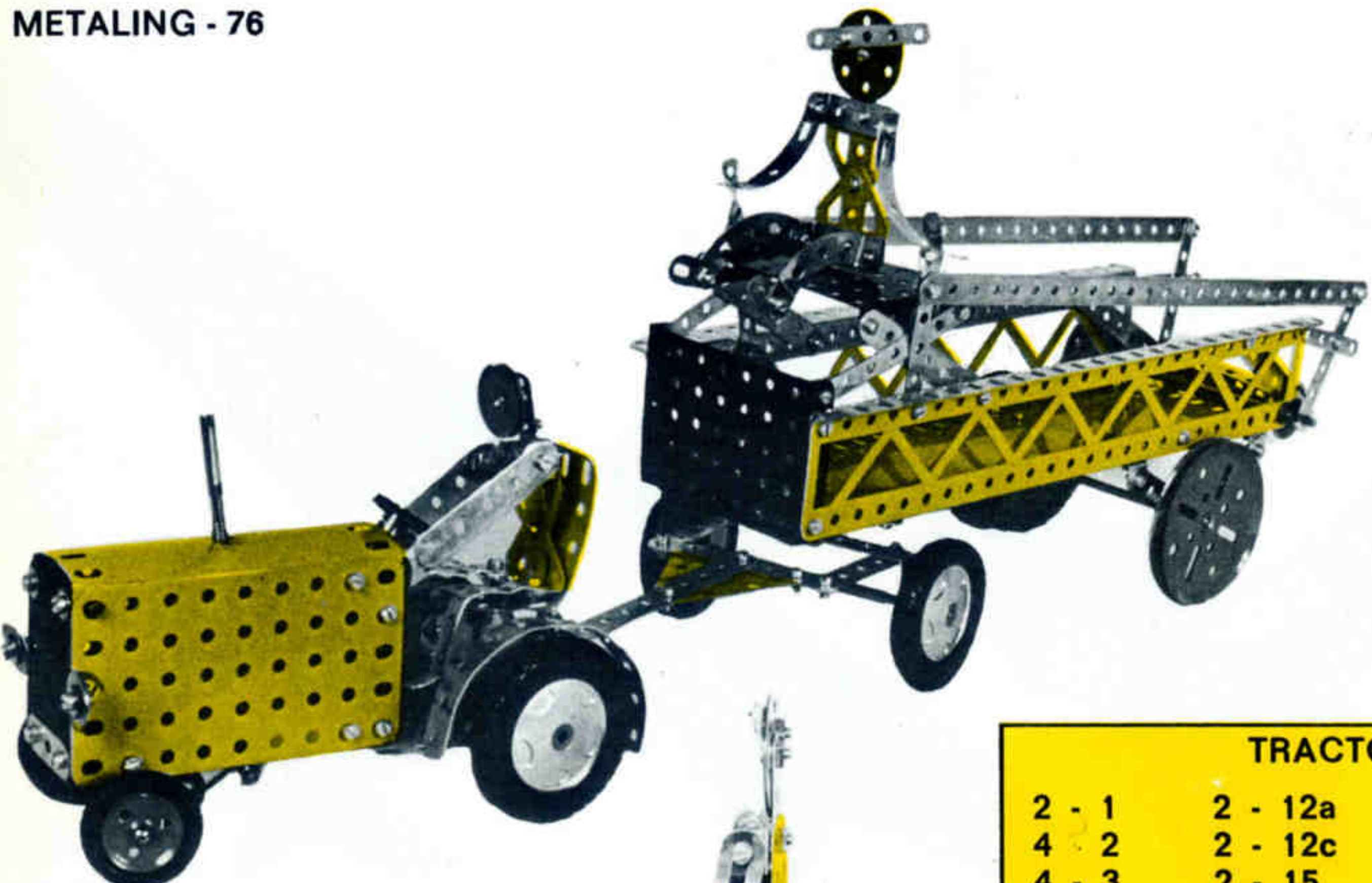

**TRACTOR Y REPARTIDOR DE ABONO 6/293**

2 - 1	2 - 12a	4 - 22	9 - 38	2 - 53a	3 - 126	1 - 197
4 - 2	2 - 12c	2 - 22a	2 - 38d	1 - 59a	2 - 142c	2 - 213
4 - 3	2 - 15	2 - 24	1 - 40	3 - 90a	2 - 155	2 - 214
14 - 5	1 - 15a	1 - 24c	1 - 45	1 - 91	1 - 176	2 - 215
2 - 6a	1 - 15b	1 - 26	2 - 48	1 - 92	4 - 187	2 - 221
4 - 8	1 - 16	1 - 27a	5 - 48a	2 - 99	1 - 188	4 - 235
7 - 10	1 - 17	2 - 35	2 - 48b	1 - 111	1 - 190	2 - 235a
2 - 11	1 - 18a	152 - 37a	1 - 51	6 - 111c	1 - 191	2 - 235b
16 - 12	2 - 19b	128 - 37b	2 - 53	1 - 126	2 - 194	30 - 374



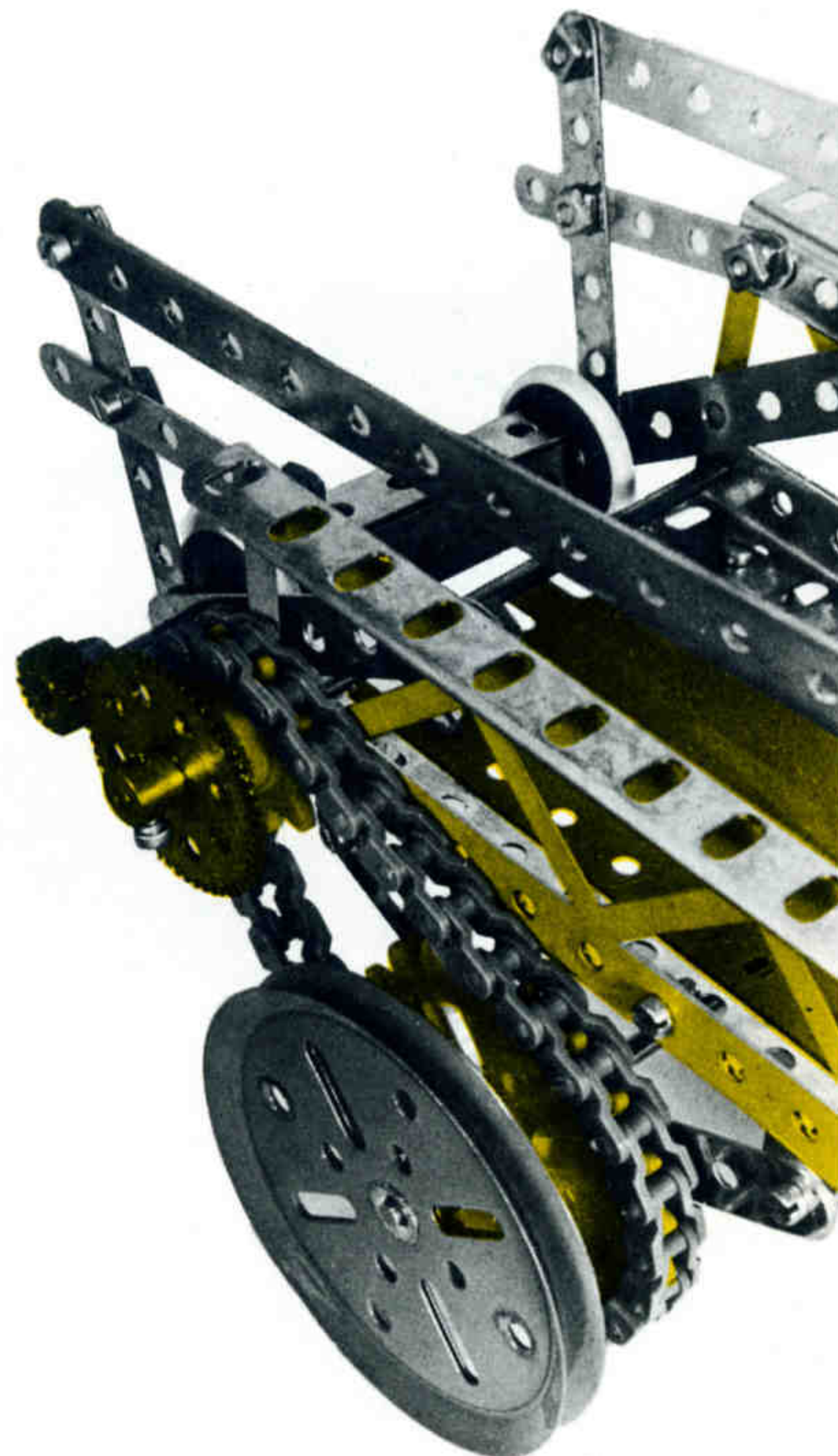
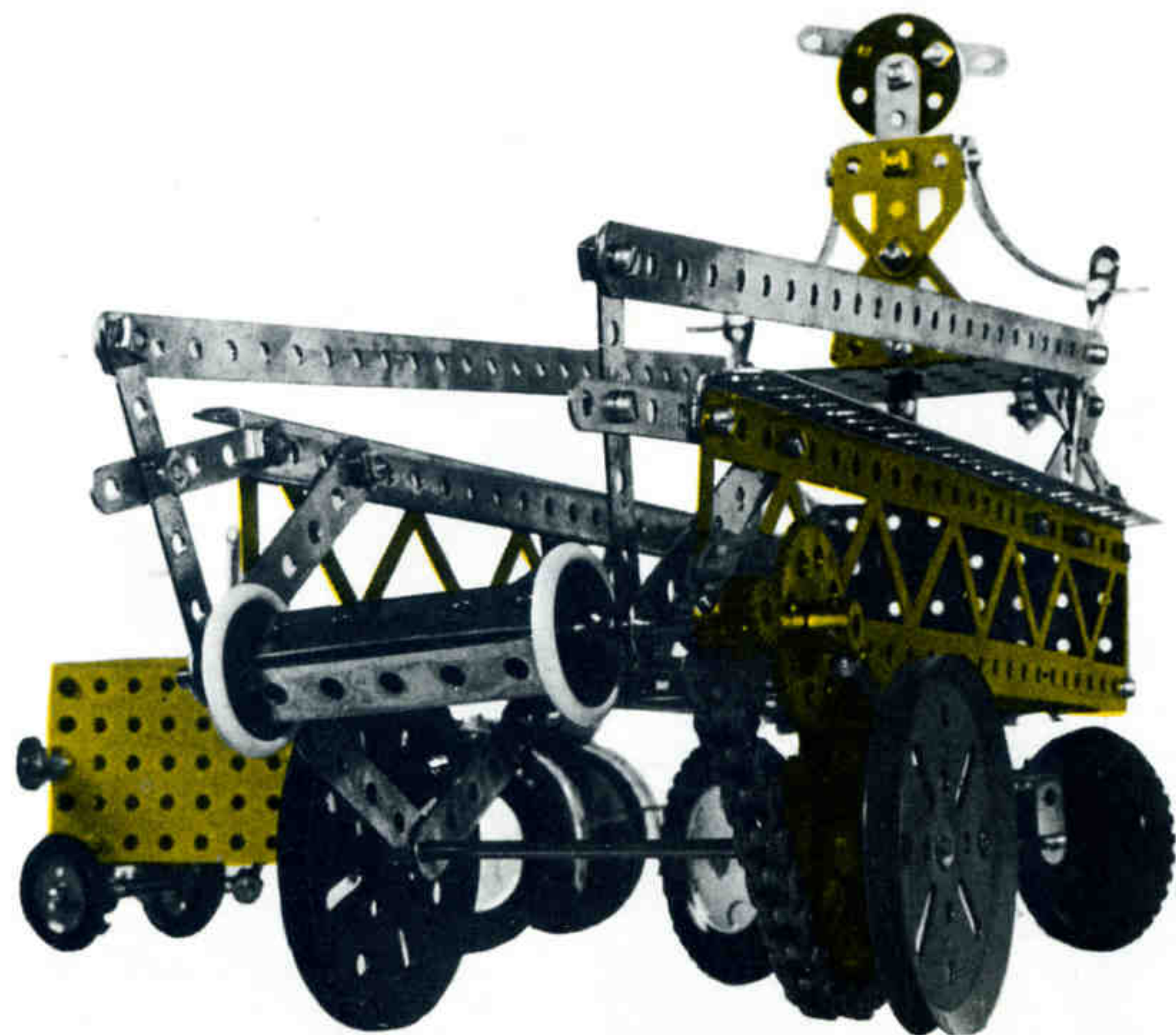
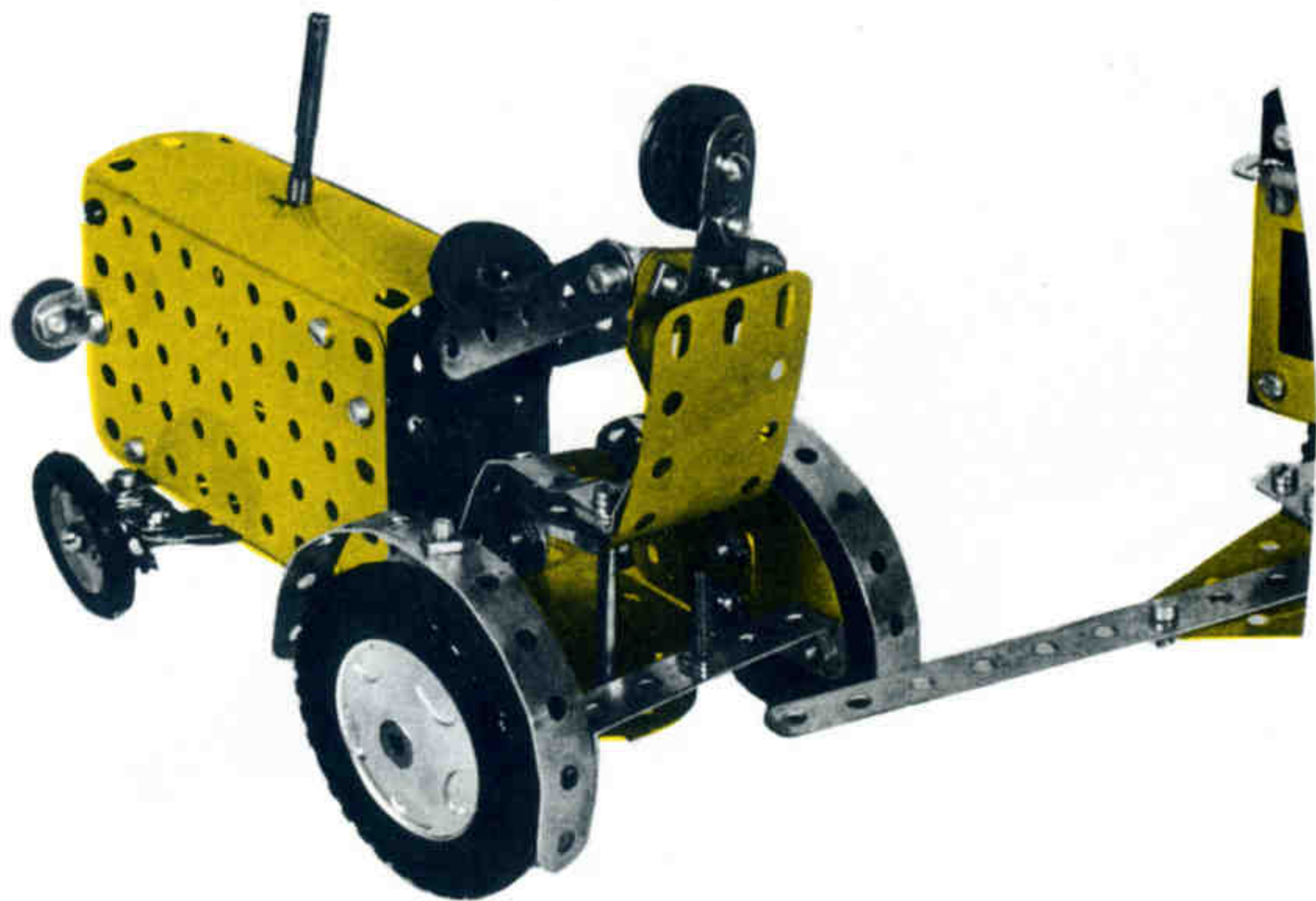

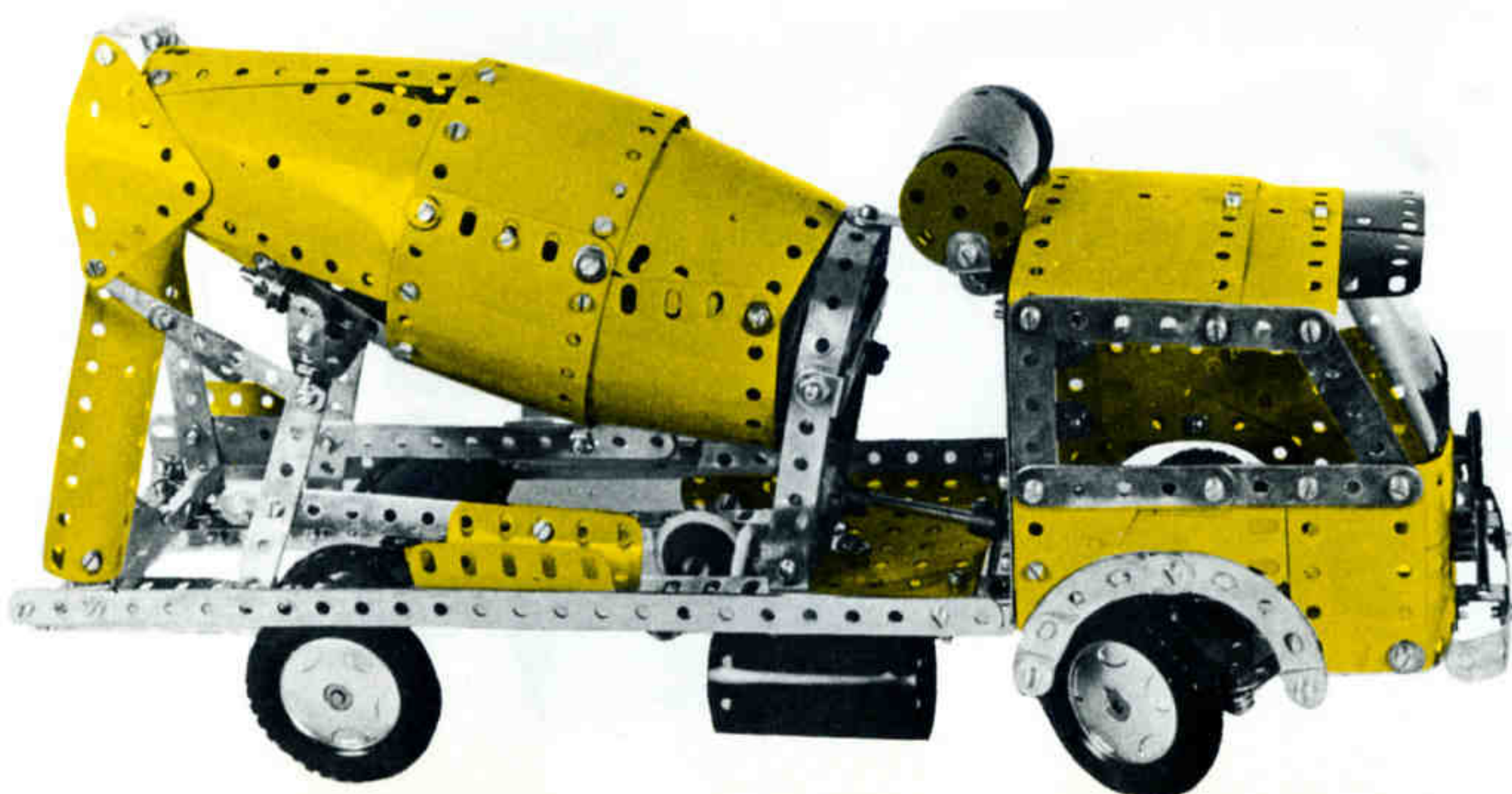
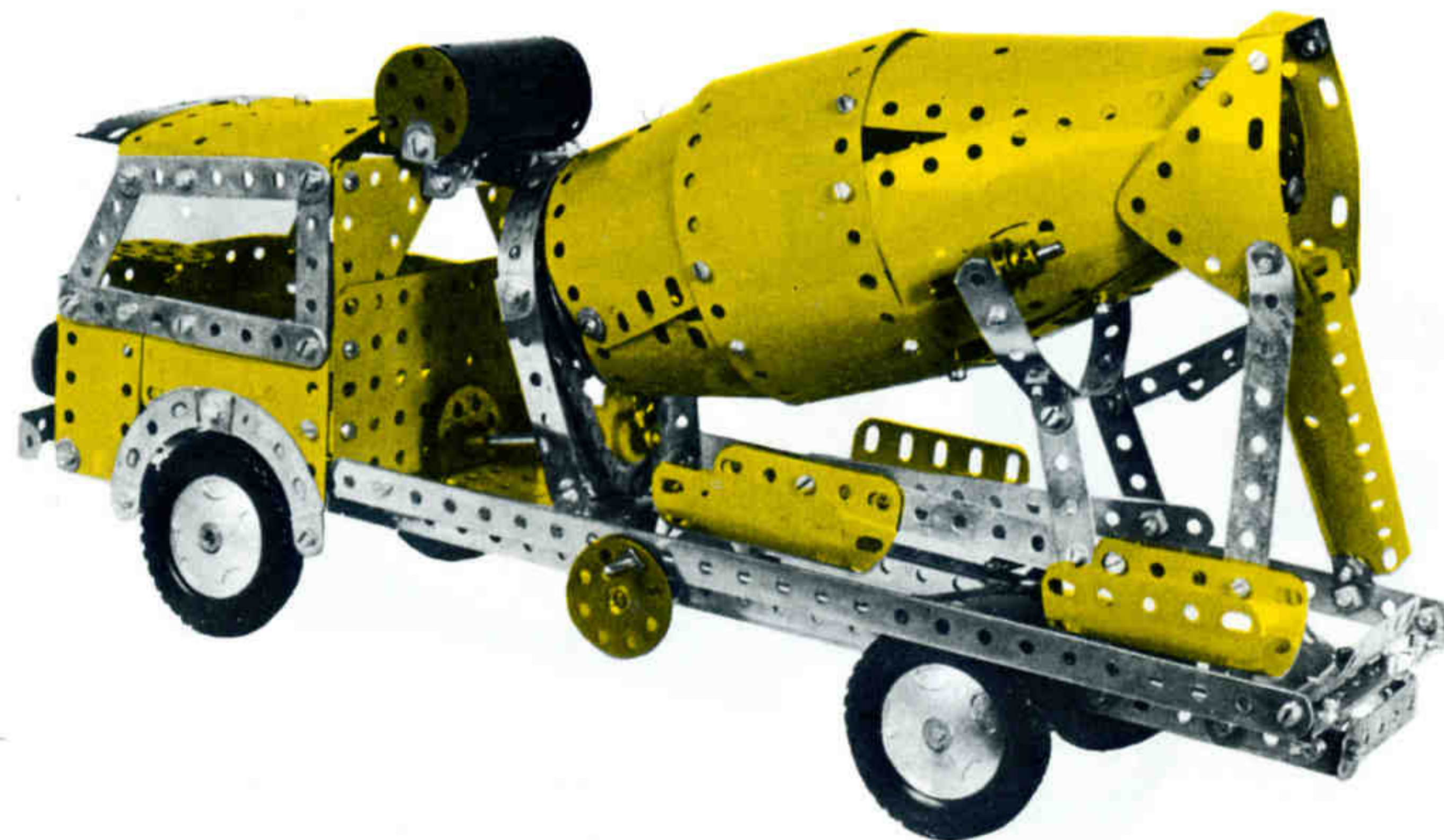



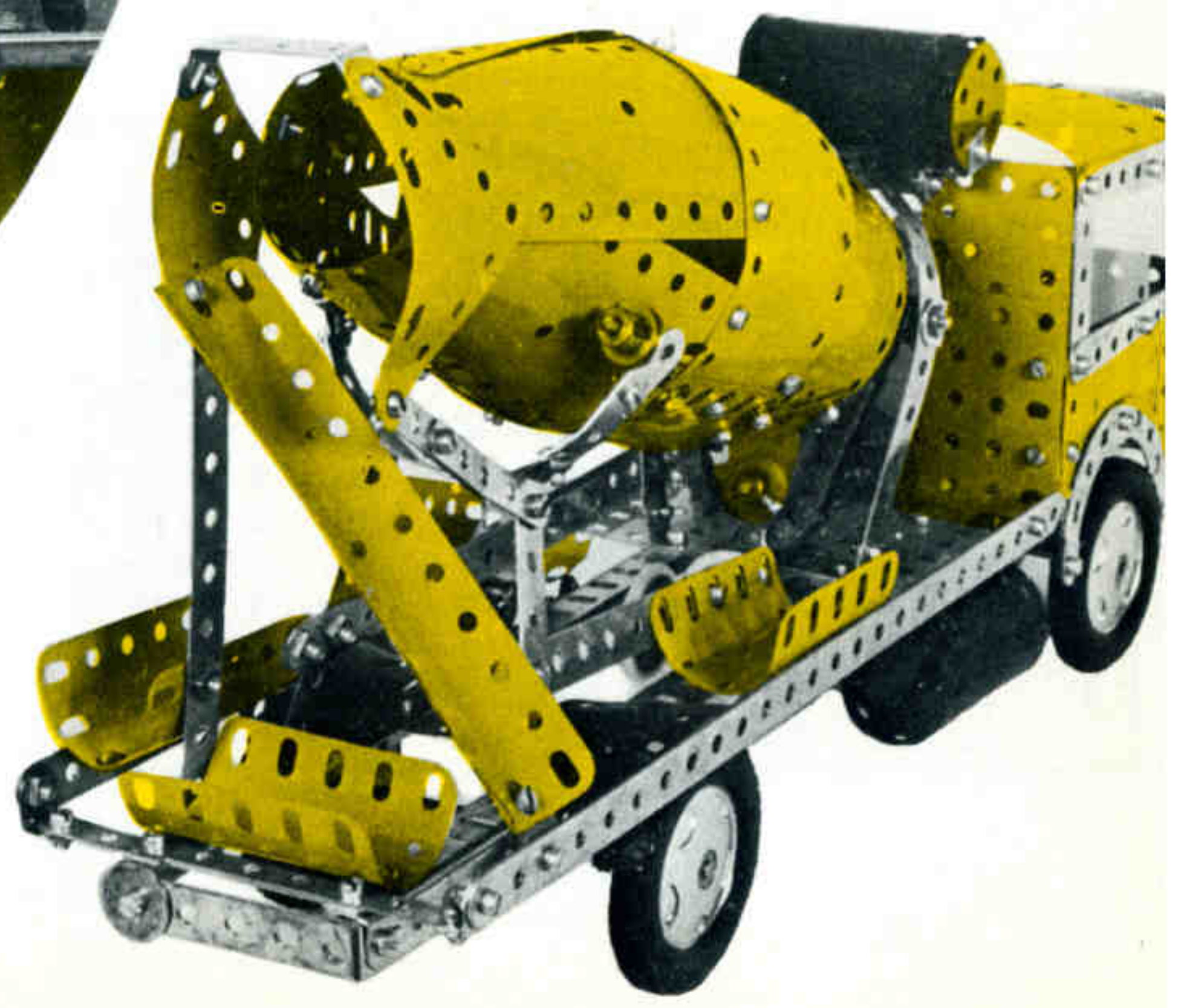
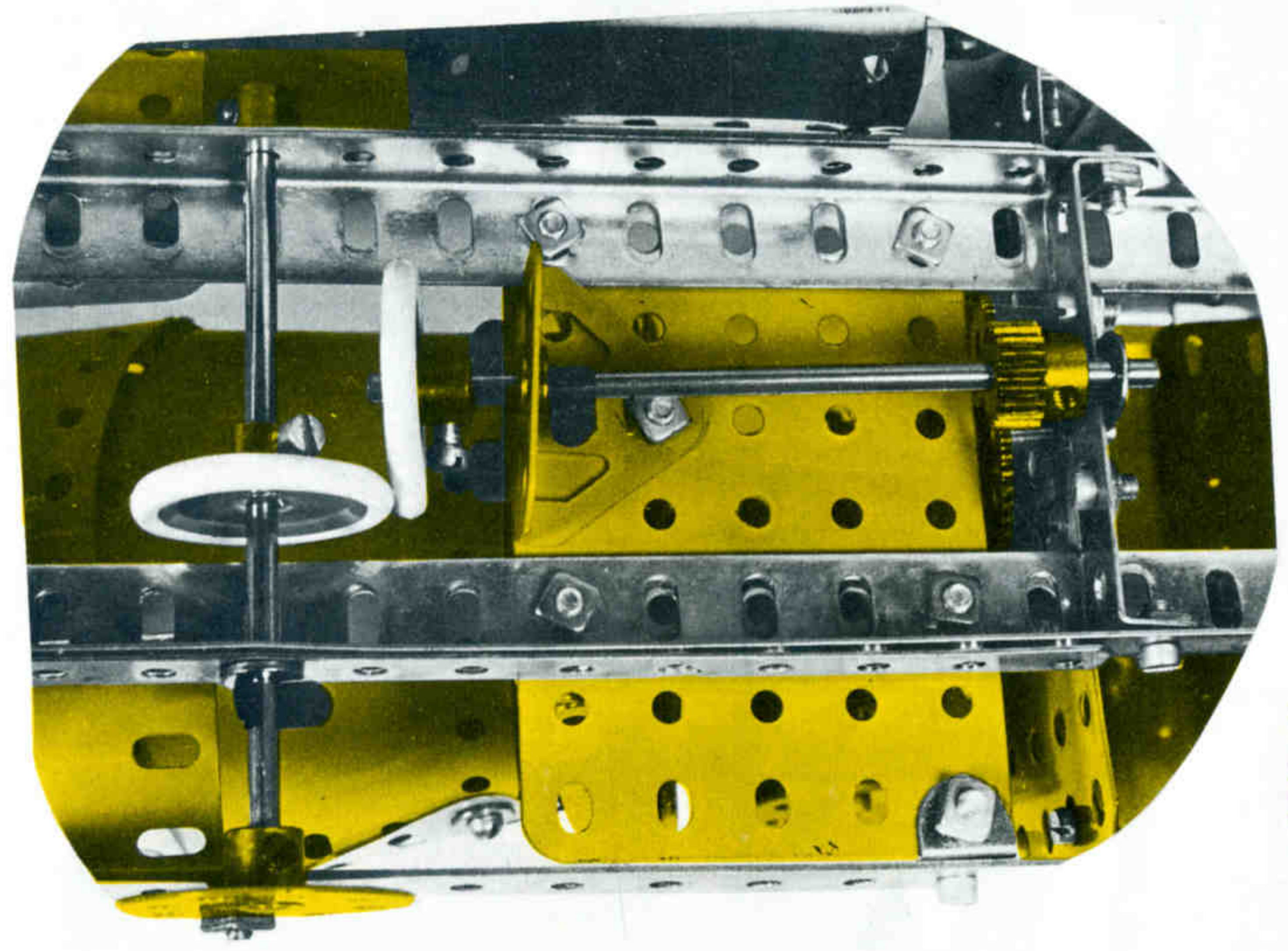
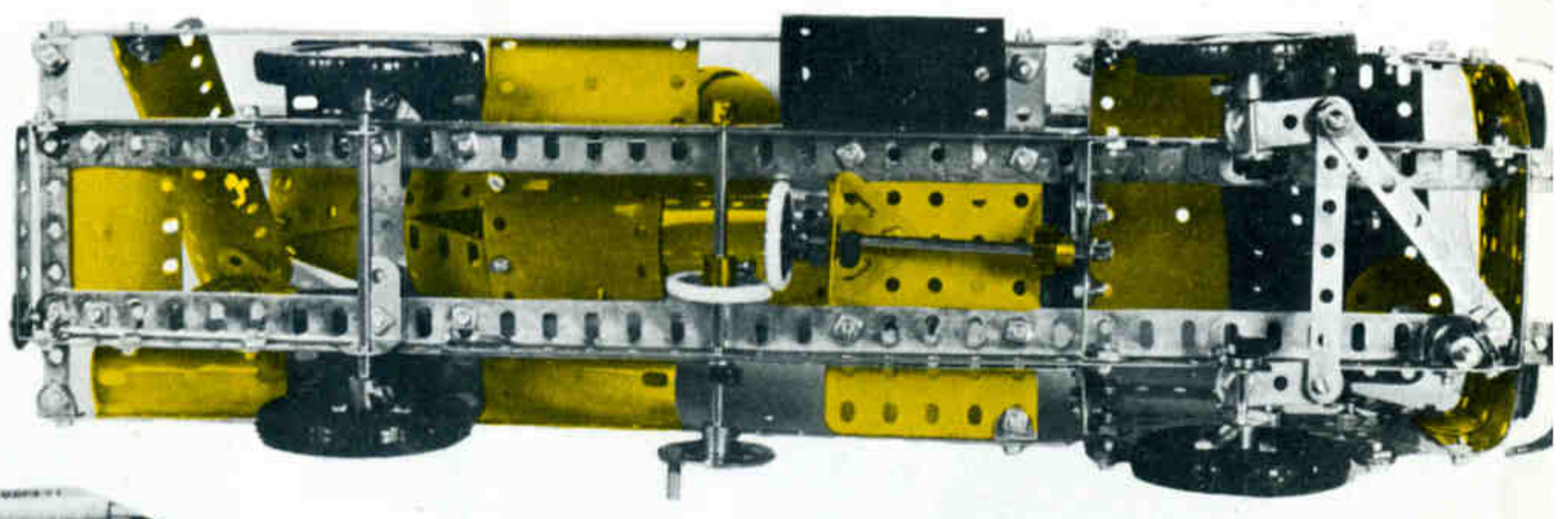

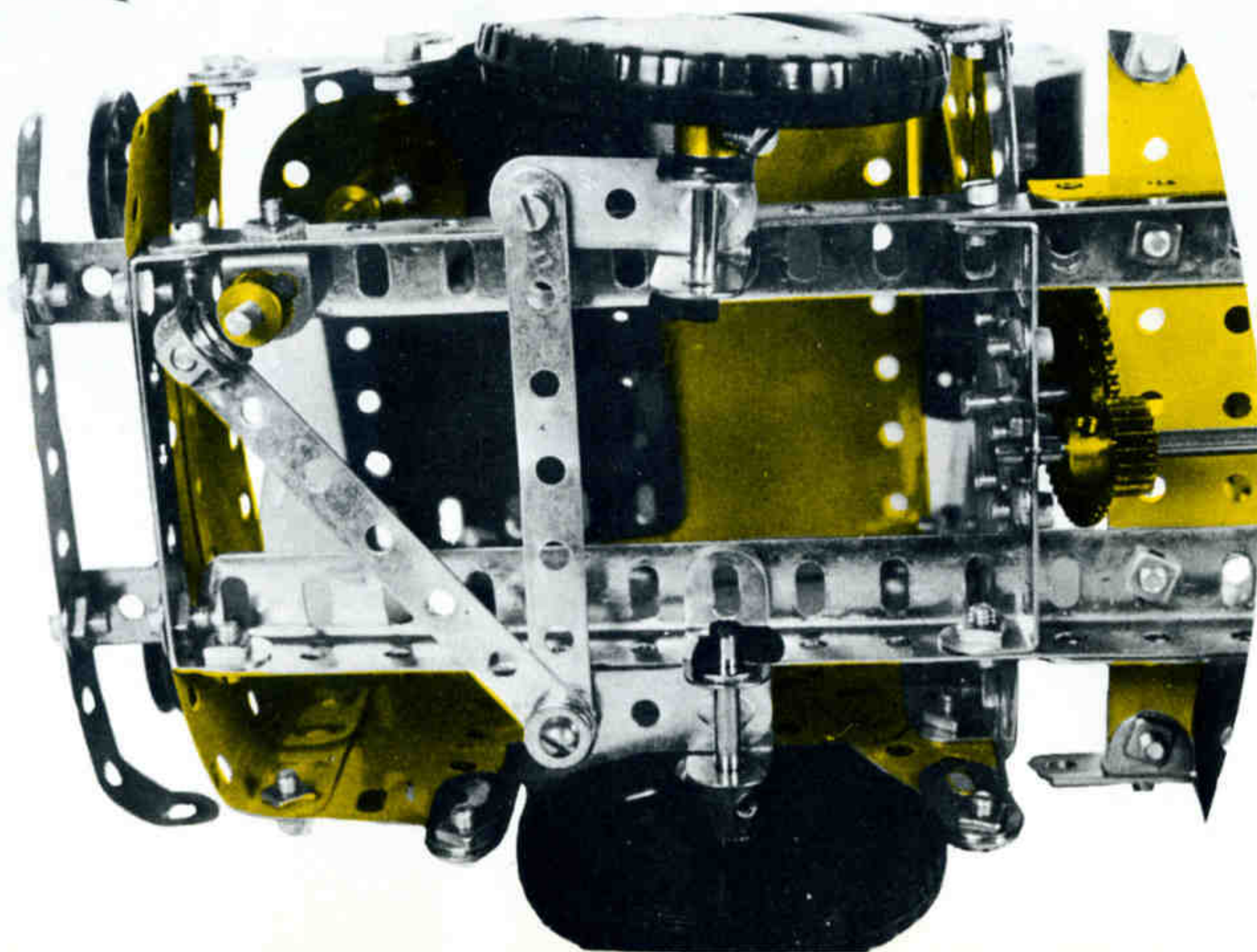
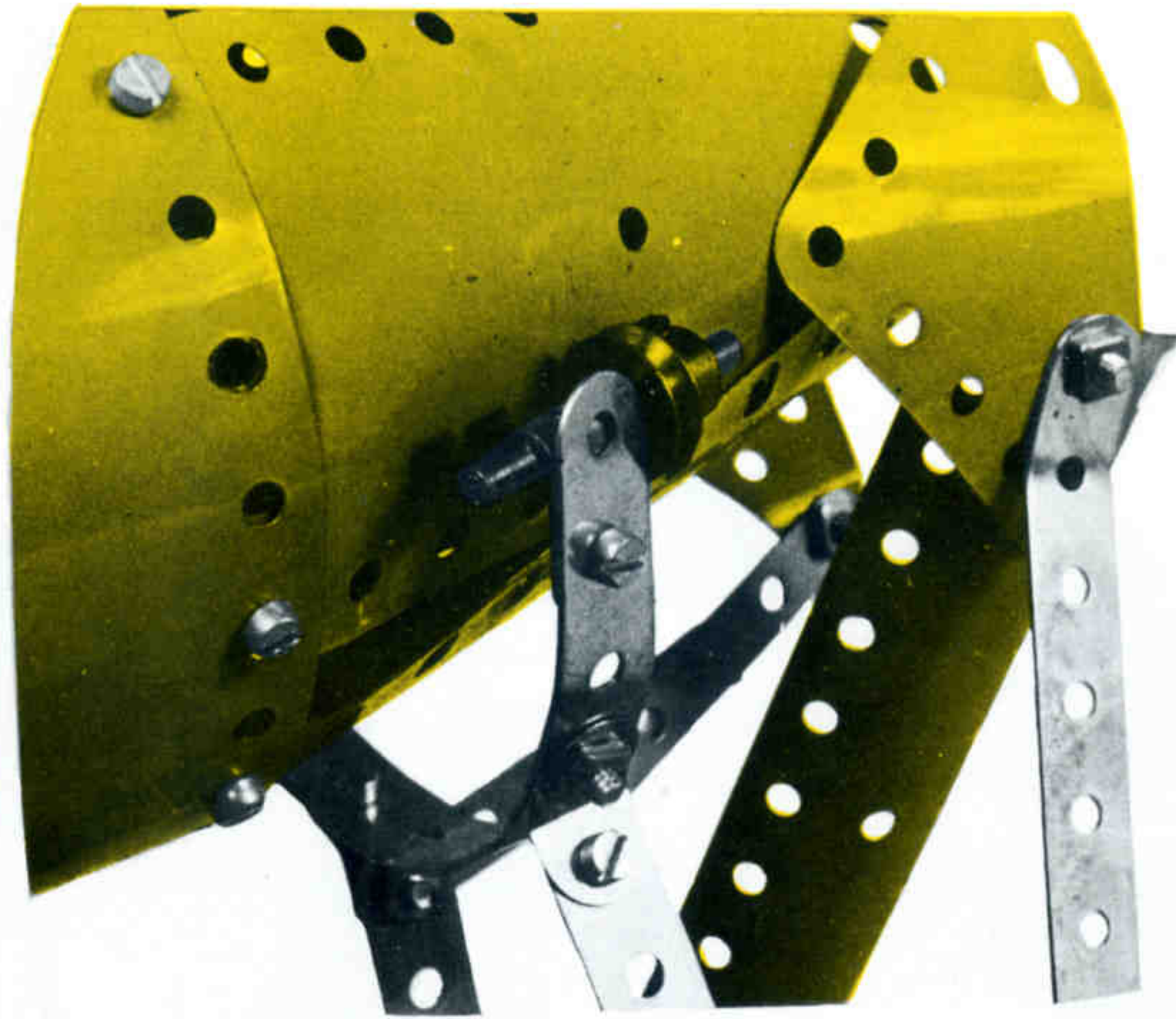
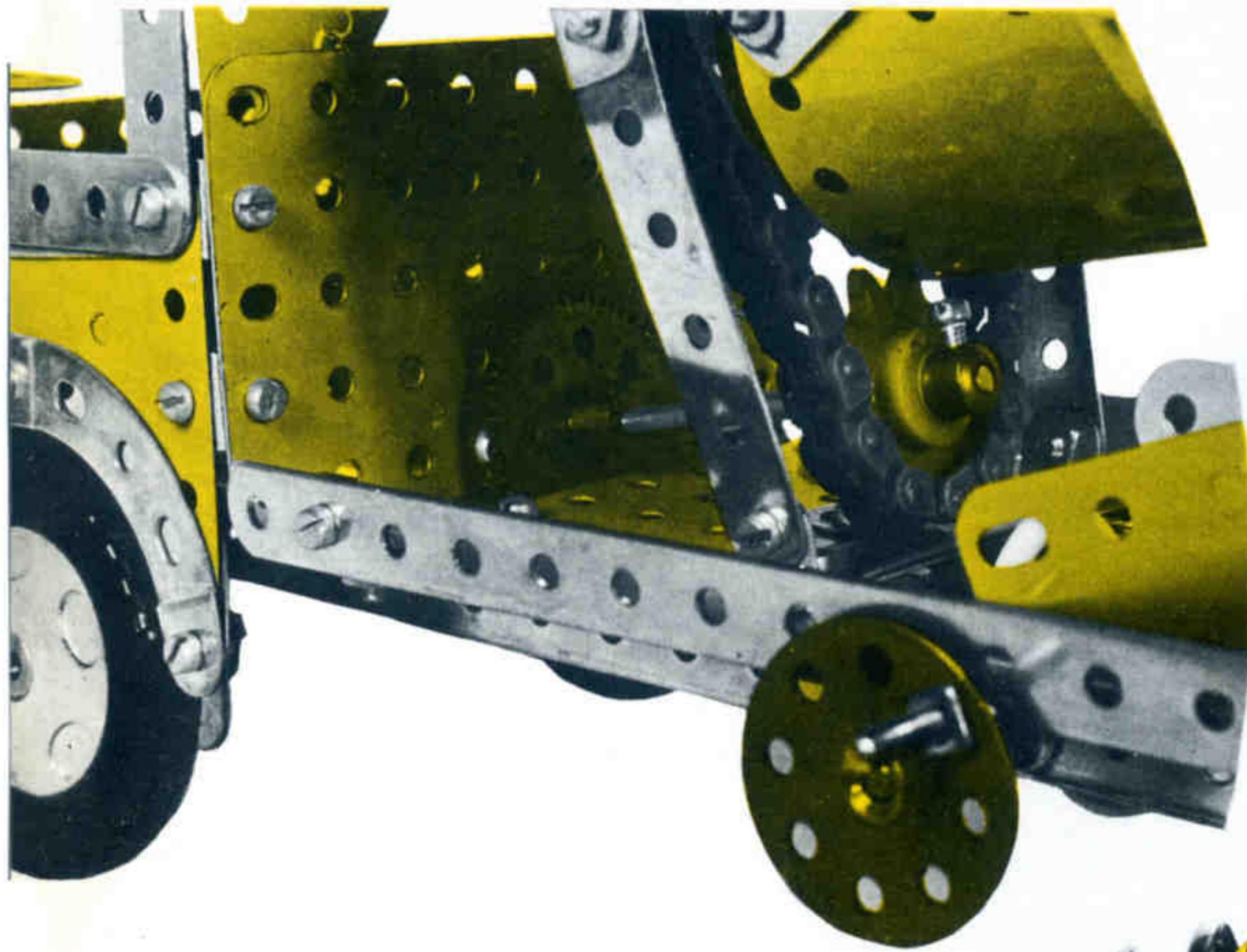

**CAMION HORMIGONERA 6/294**

2 - 1	2 - 15b	140 - 37b	4 - 125	2 - 194a
7 - 2	4 - 16	26 - 38	1 - 126	2 - 194c
4 - 3	4 - 18a	1 - 38d	2 - 155	1 - 197
8 - 5	1 - 19b	2 - 48	4 - 187	1 - 199
2 - 6a	4 - 22	4 - 48a	4 - 188	1 - 200
4 - 8	1 - 23	1 - 48b	4 - 189	2 - 212a
8 - 10	1 - 23a	2 - 53a	4 - 190	4 - 221
4 - 11	2 - 24	3 - 59	2 - 191	2 - 222
1 - 11a	2 - 24c	4 - 90a	4 - 192	2 - 223
16 - 12	1 - 26	1 - 91	2 - 193a	3 - 235
2 - 12a	1 - 27a	1 - 92	1 - 193c	4 - 235b
3 - 12c	10 - 35	5 - 111c	1 - 193e	26 - 374
1 - 15a	152 - 37a	1 - 115	2 - 194	

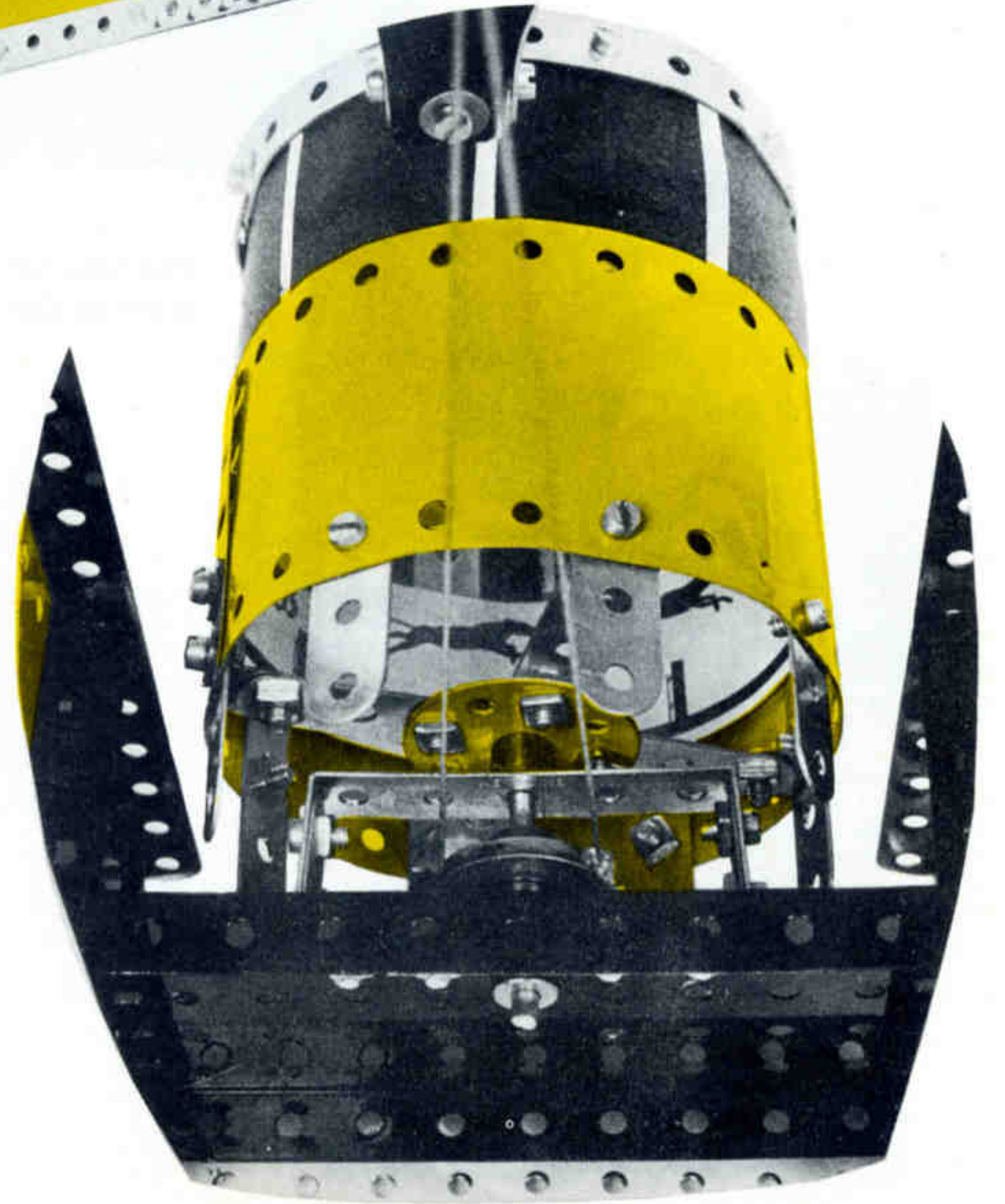
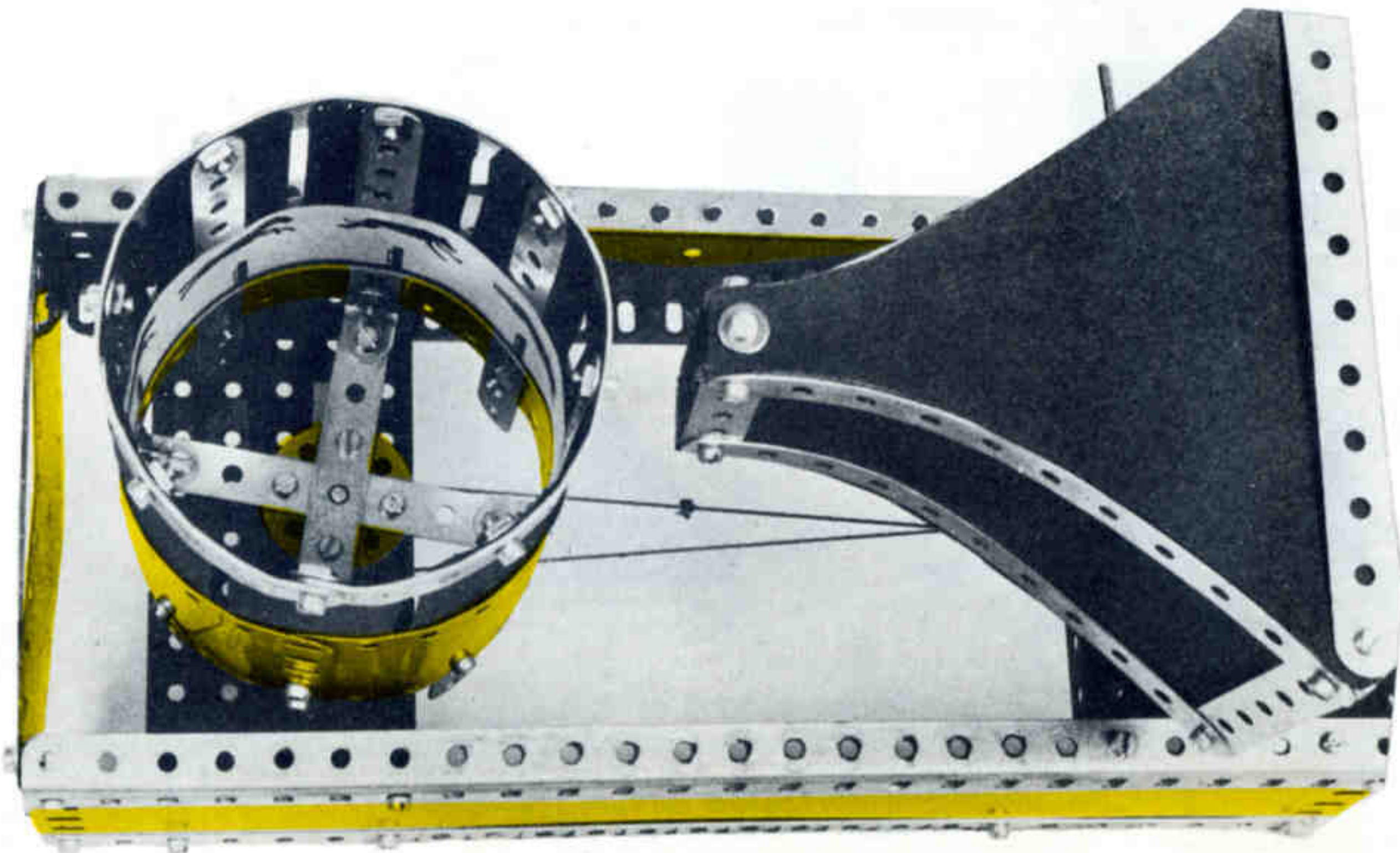
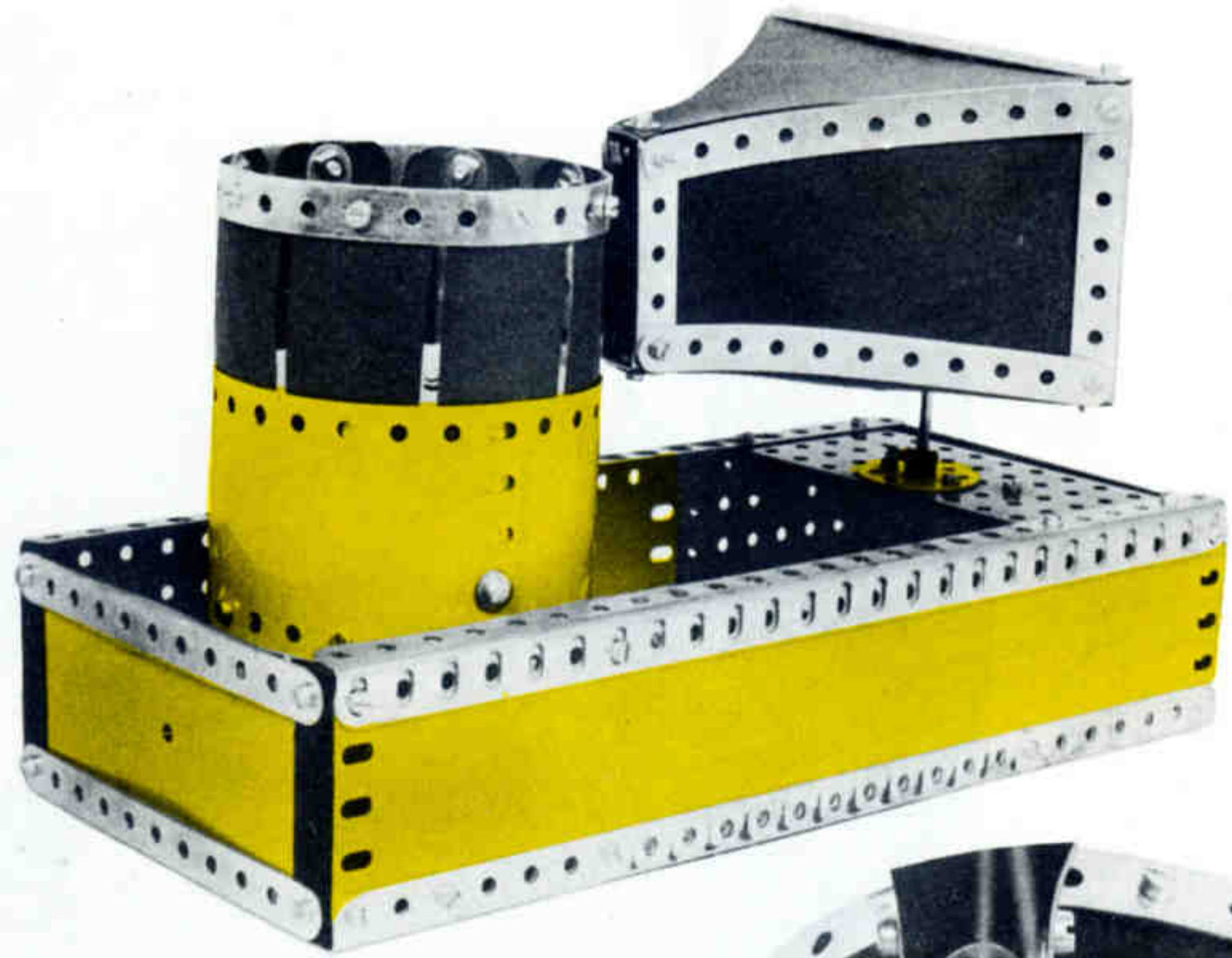
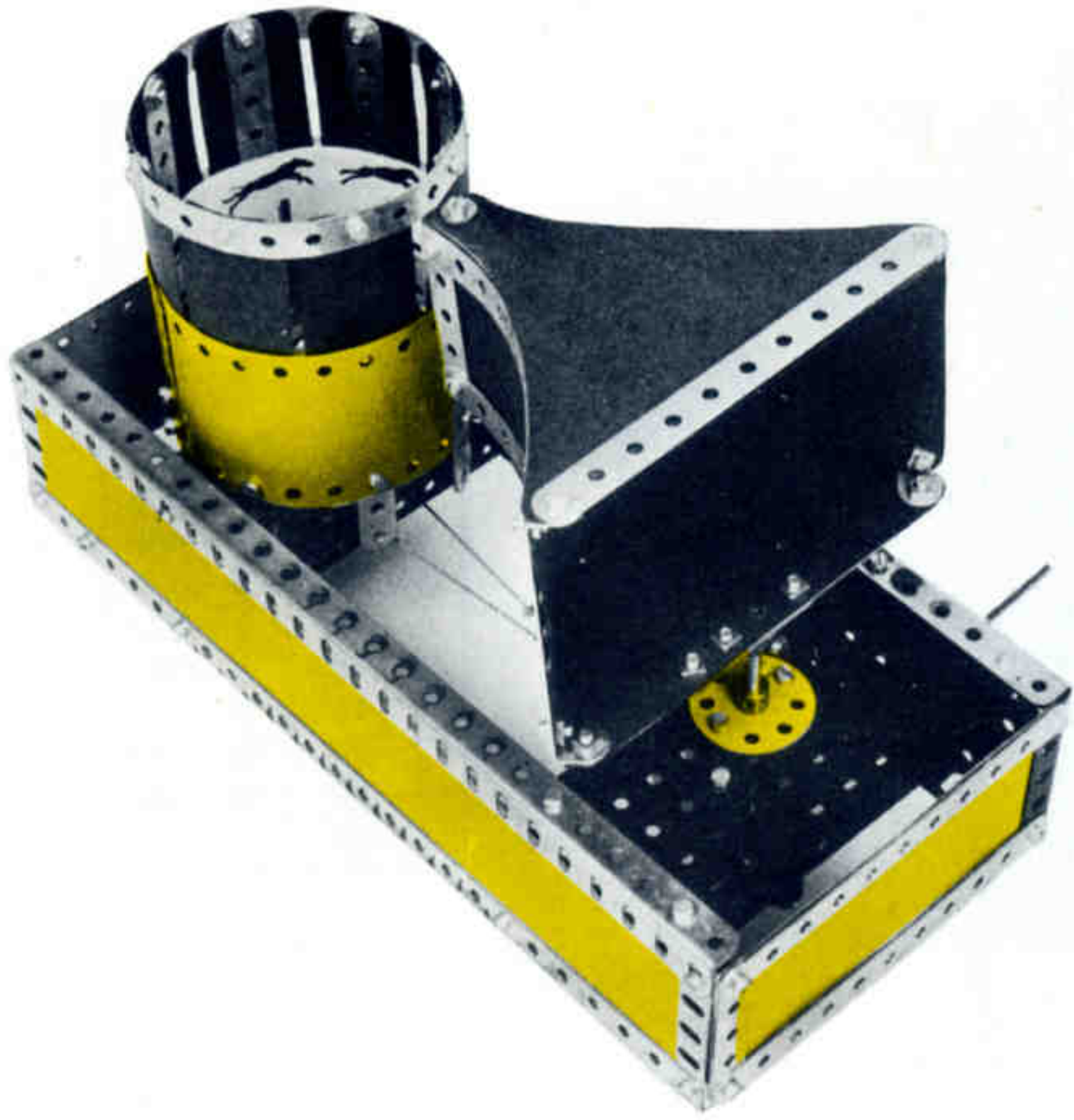

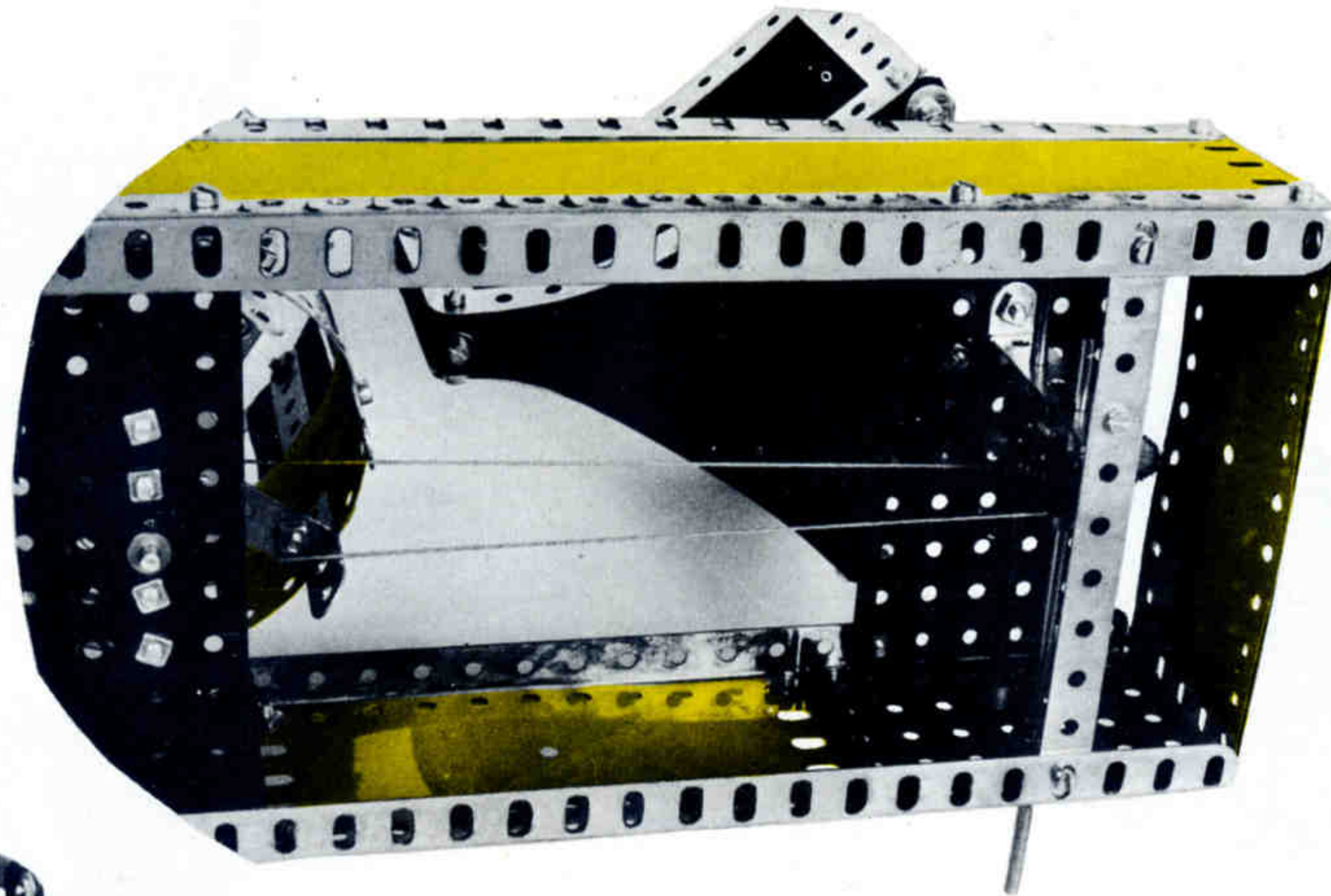

ZOOTROPO 8/295	
1 - 1	1 - 27a
18 - 2	91 - 37a
6 - 3	91 - 37b
3 - 5	5 - 38
4 - 8	1 - 40
2 - 11	1 - 46
6 - 12	1 - 48a
2 - 12a	2 - 48b
1 - 15a	2 - 52
1 - 17	3 - 53
1 - 18a	3 - 59
1 - 19	2 - 62
2 - 22	3 - 192
2 - 24	2 - 197
1 - 26	

Funciona el tambor, en sentido contrario a las agujas del reloj.

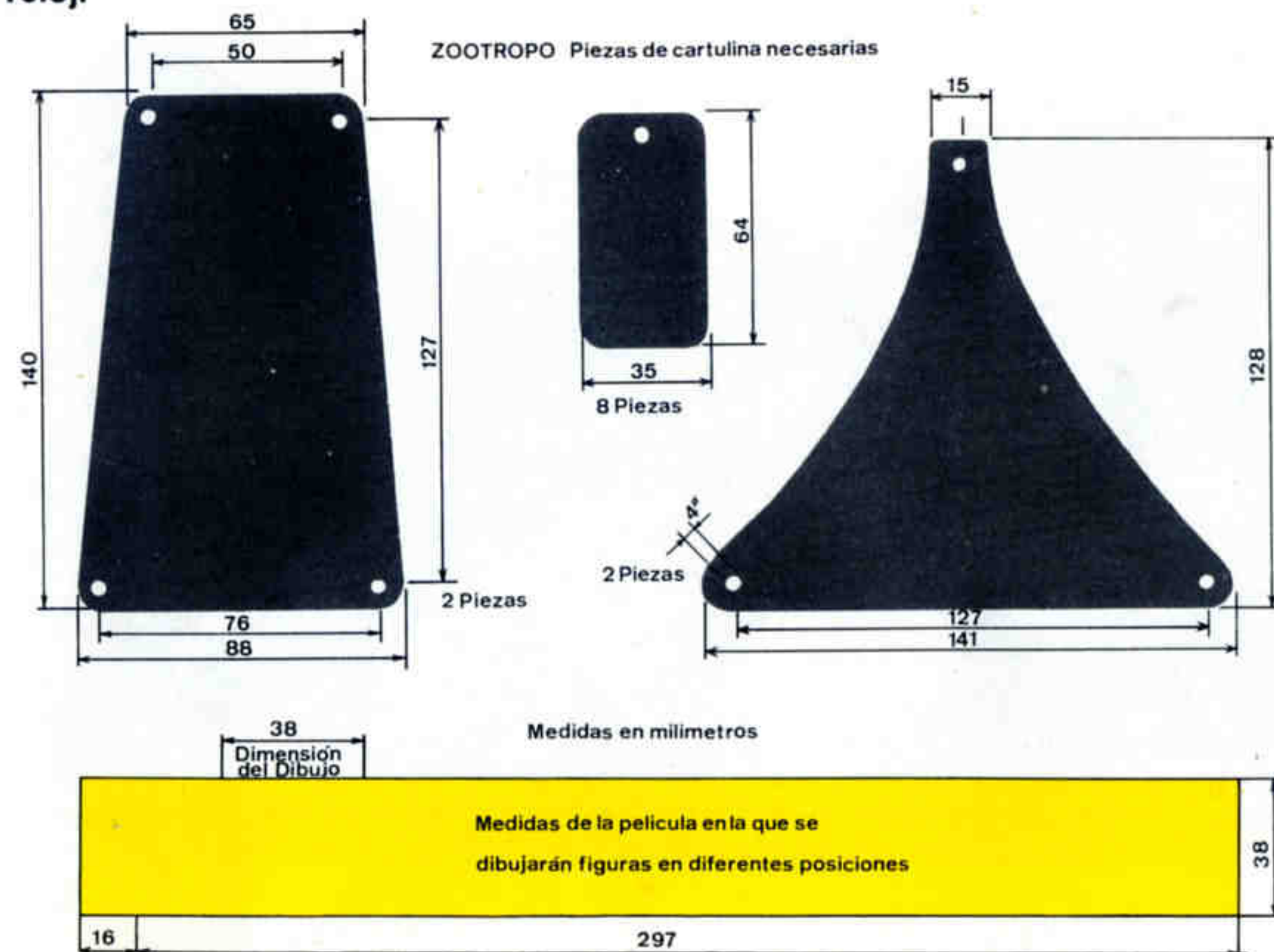
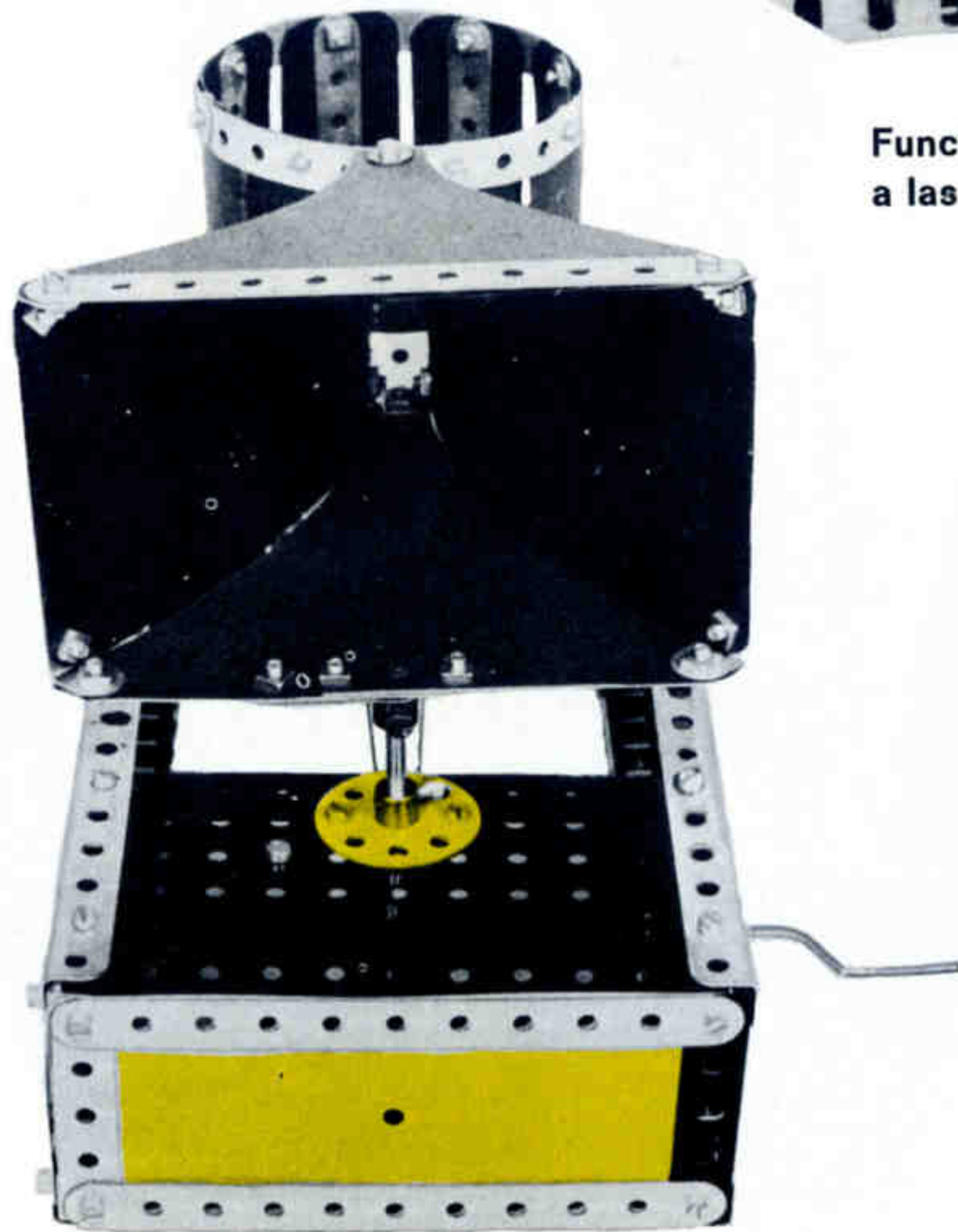

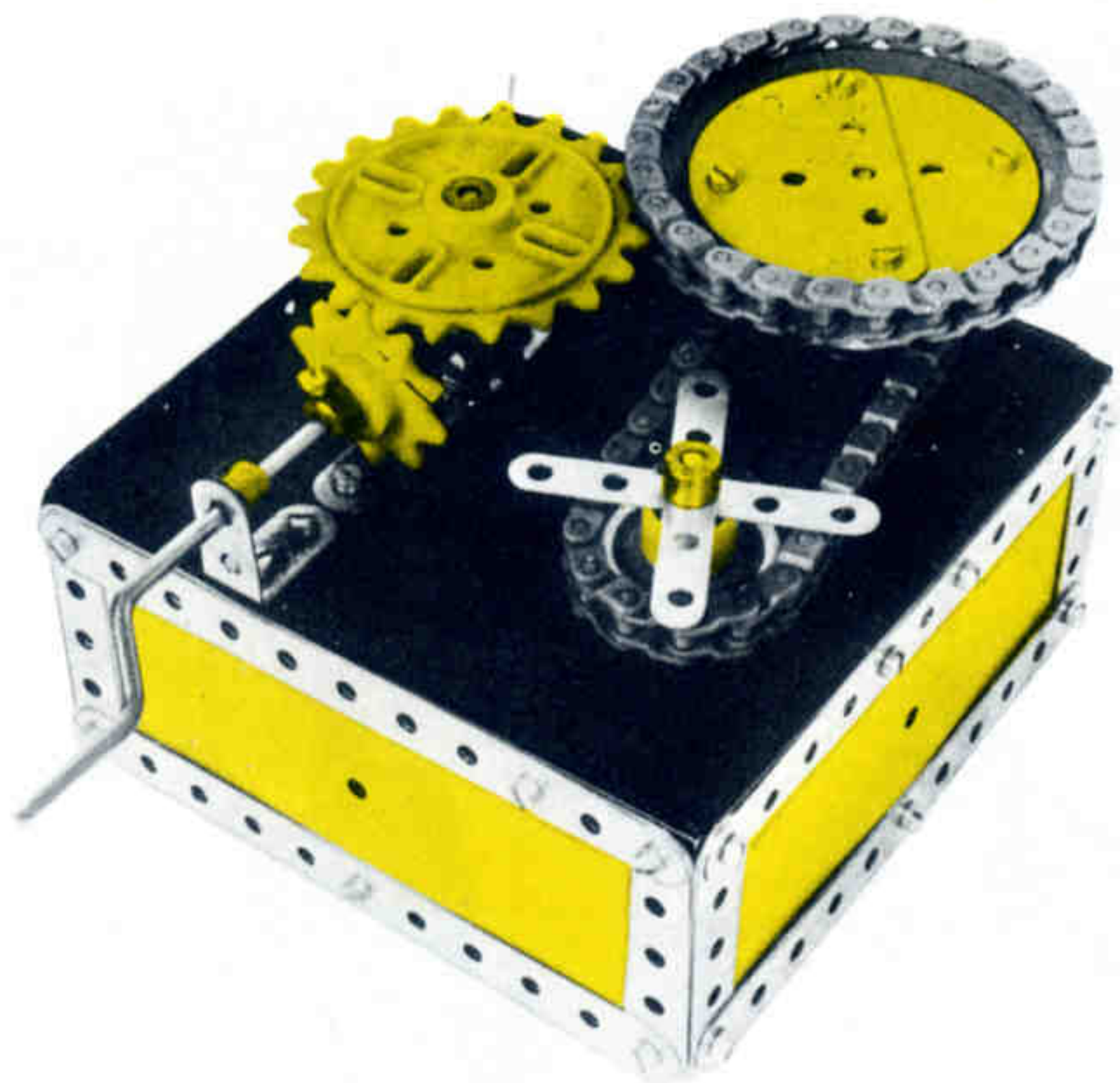

**TRANSMISIONES  
EN CADENA  
Y ENGRANAJES  
EN ANGULO  
METALING 8/296**

8 - 2	2 - 38d
8 - 5	1 - 45
1 - 6	2 - 48a
1 - 11	2 - 52
4 - 12	5 - 59
2 - 12a	1 - 91
2 - 16	1 - 92
1 - 17	2 - 155
1 - 19b	1 - 164
1 - 19	4 - 192
2 - 22	2 - 214
40 - 37a	2 - 235
40 - 37b	54 - 374
10 - 38	

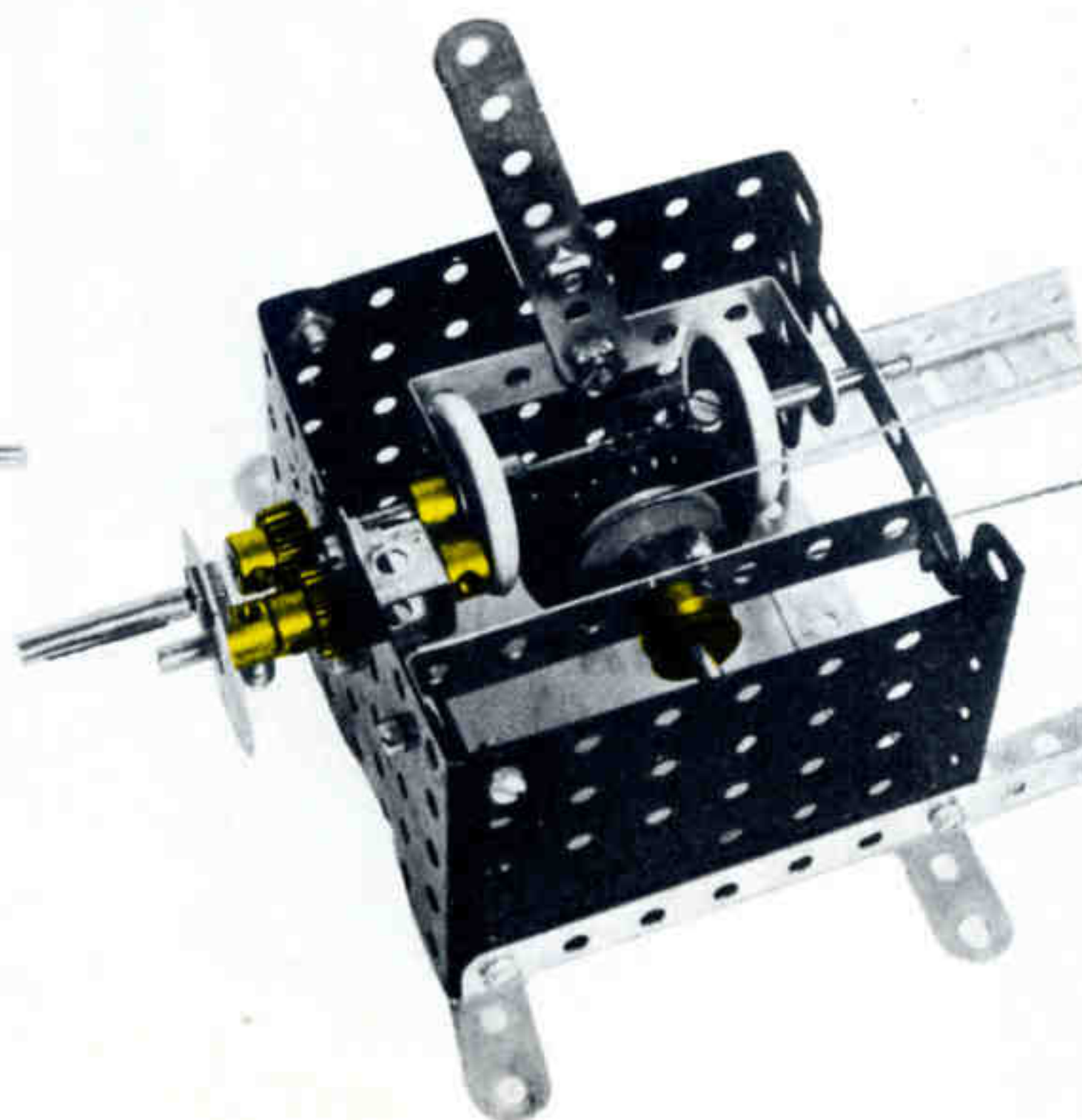
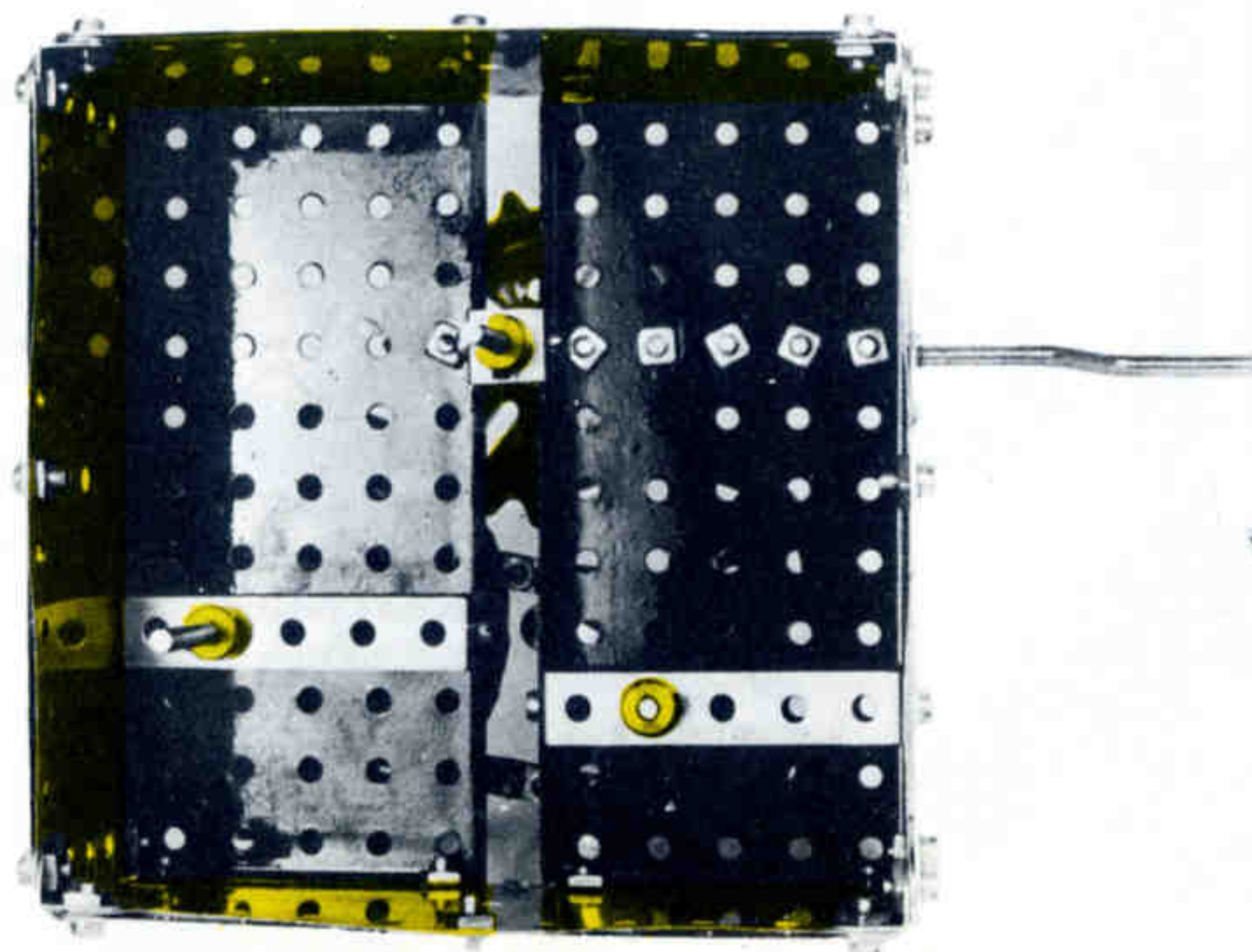
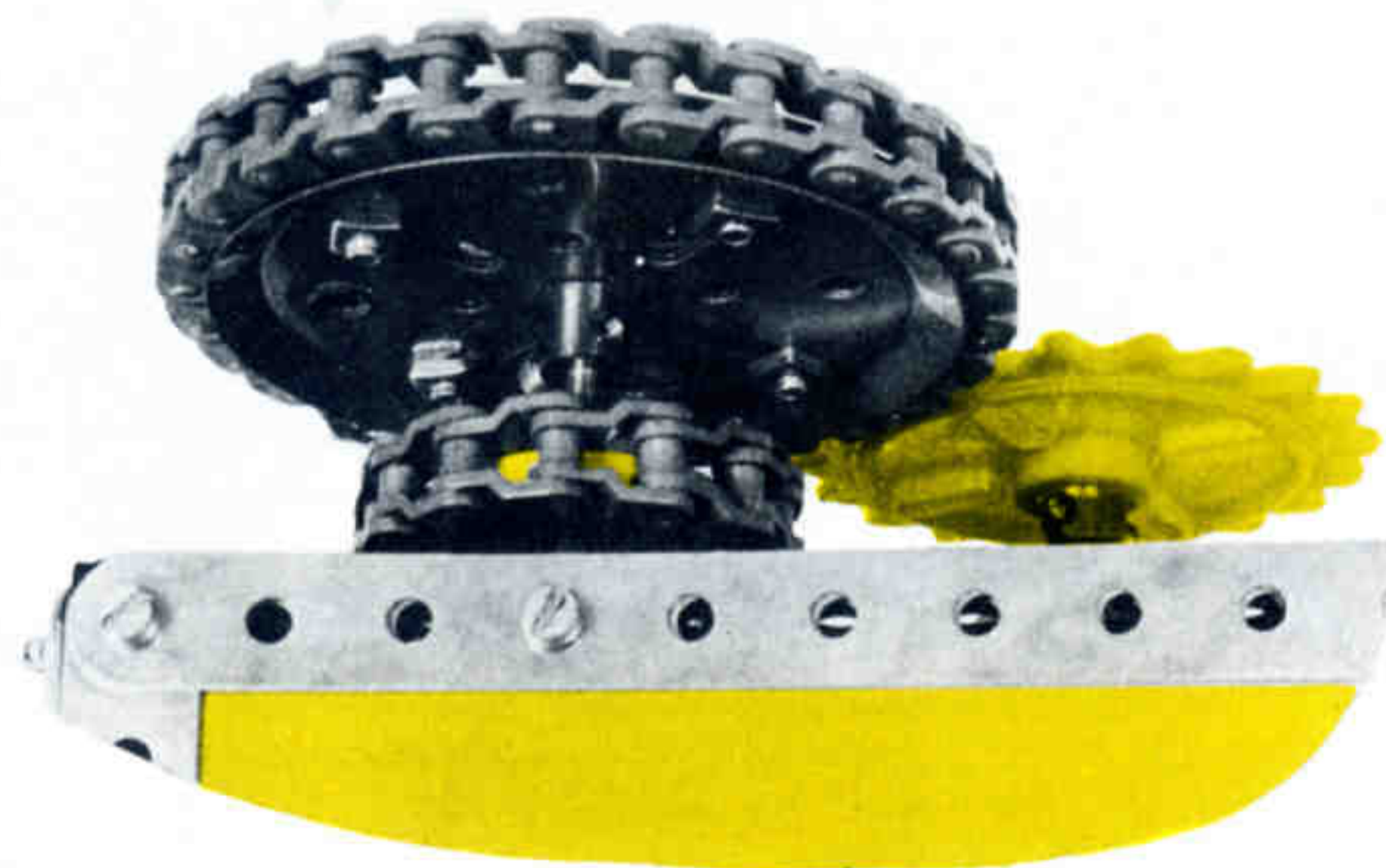

**VAGONETA  
SIN FIN 8/297**

9 - 2	1 - 46
1 - 3	2 - 48b
6 - 5	2 - 52
8 - 8	3 - 53
10 - 10	1 - 57
14 - 12	6 - 59
1 - 15a	4 - 90a
3 - 16	5 - 111c
2 - 17	3 - 125
4 - 20b	1 - 142c
4 - 22	2 - 155
1 - 22a	4 - 189
1 - 23a	1 - 191
1 - 24	4 - 192
2 - 26	2 - 194c
150 - 37a	2 - 194d
147 - 37b	1 - 213
12 - 38	2 - 223
1 - 40	2 - 235a
1 - 45	2 - 235b

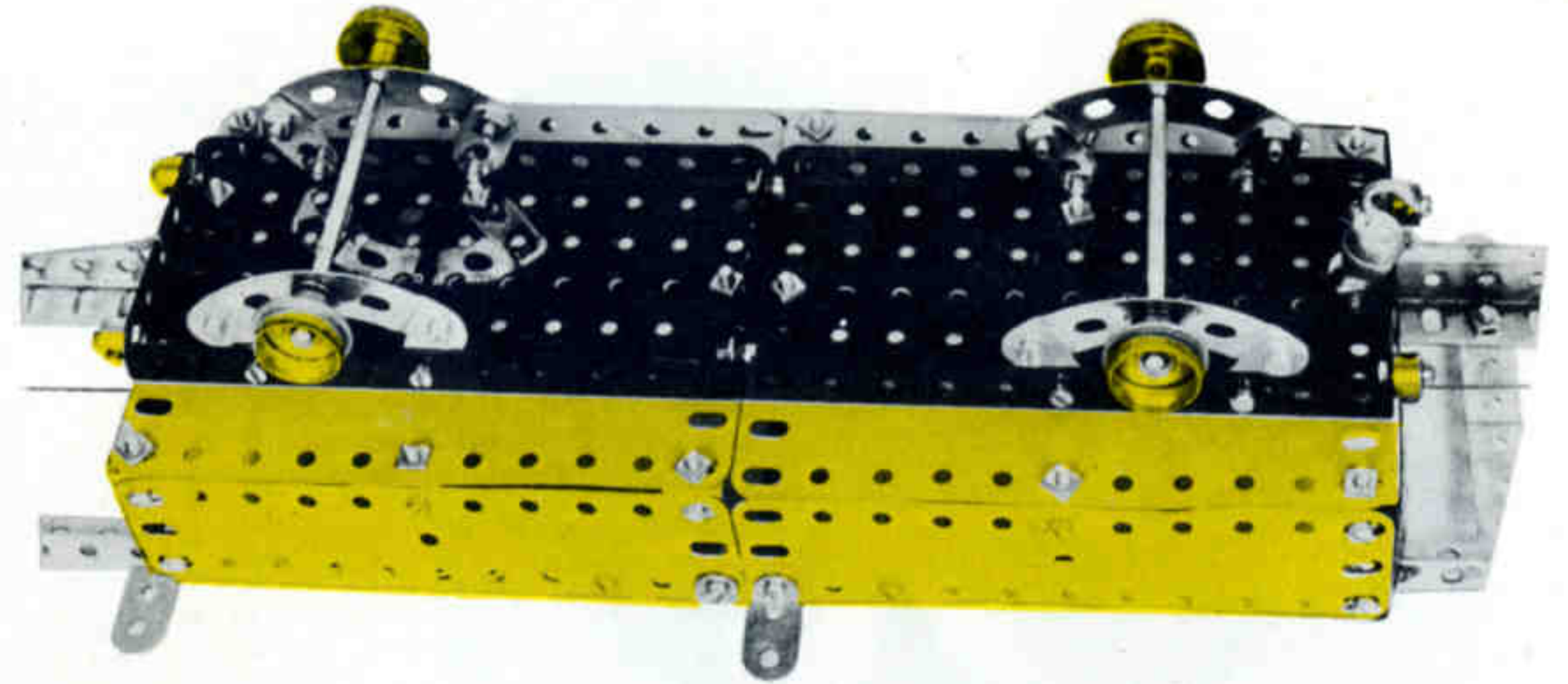
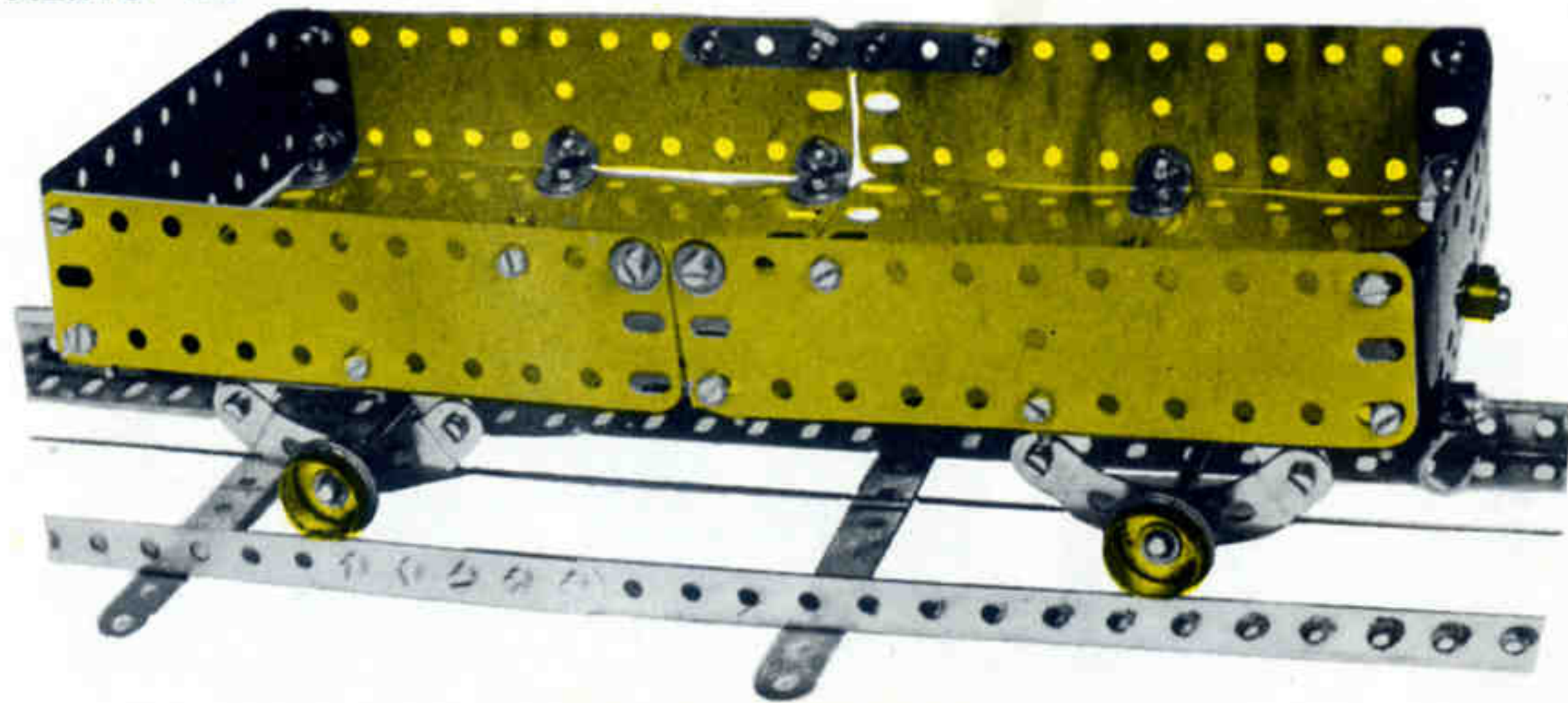

**NORIA 8 298**

12 - 1	1 - 26	1 - 91
18 - 2	1 - 32	1 - 92
6 - 3	16 - 35	2 - 99
2 - 4	204 - 37a	4 - 111c
14 - 5	195 - 37b	2 - 126a
4 - 6	23 - 38	1 - 164
4 - 6a	1 - 46	2 - 188
8 - 8	10 - 48a	2 - 190
12 - 10	2 - 48b	2 - 191
1 - 11	2 - 52	6 - 192
18 - 12	2 - 53a	4 - 221
4 - 12c	2 - 54	1 - 235
1 - 14	3 - 59	4 - 235a
4 - 16	2 - 62	63 - 374
1 - 19	1 - 80c	
2 - 24	8 - 90	

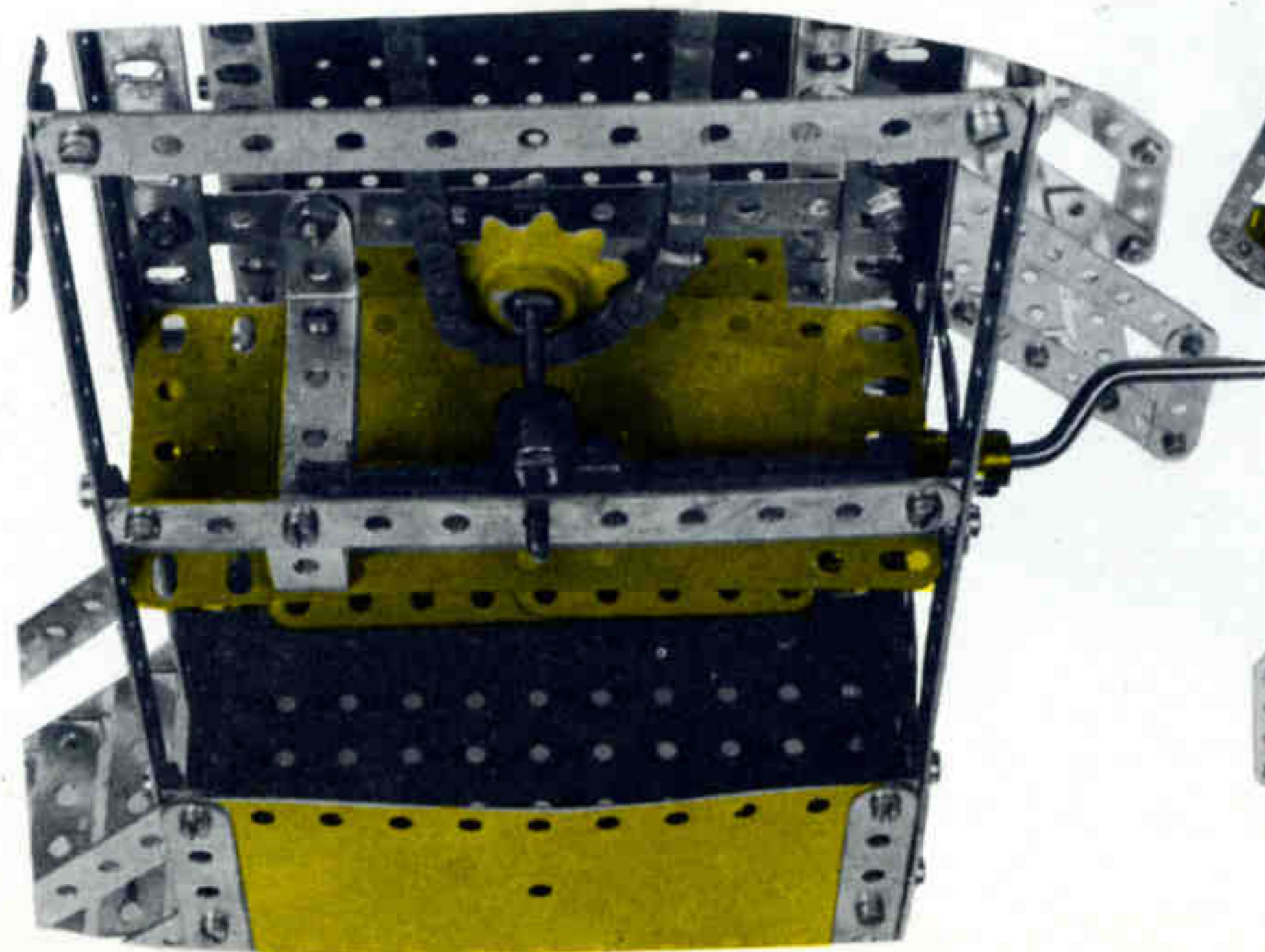
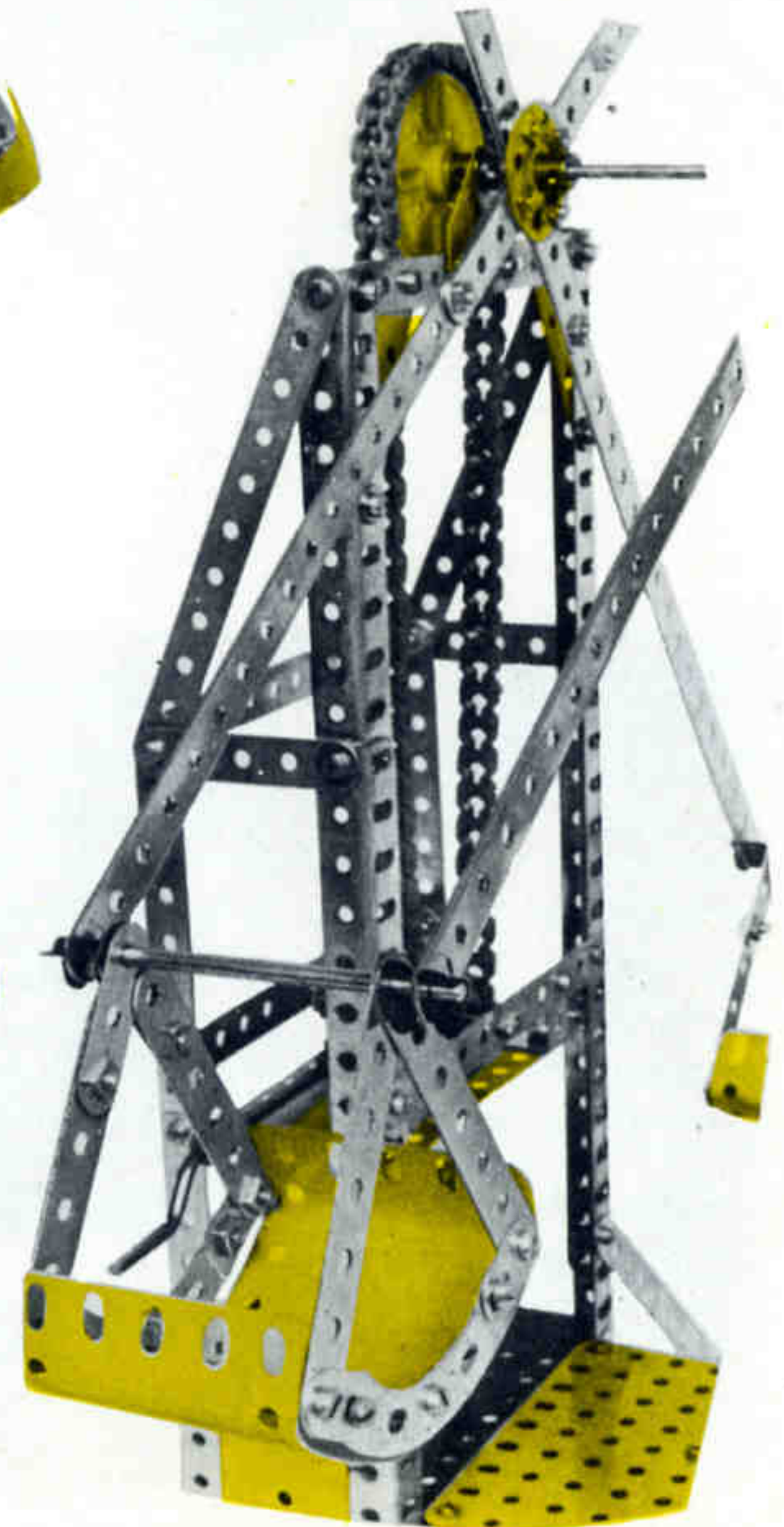
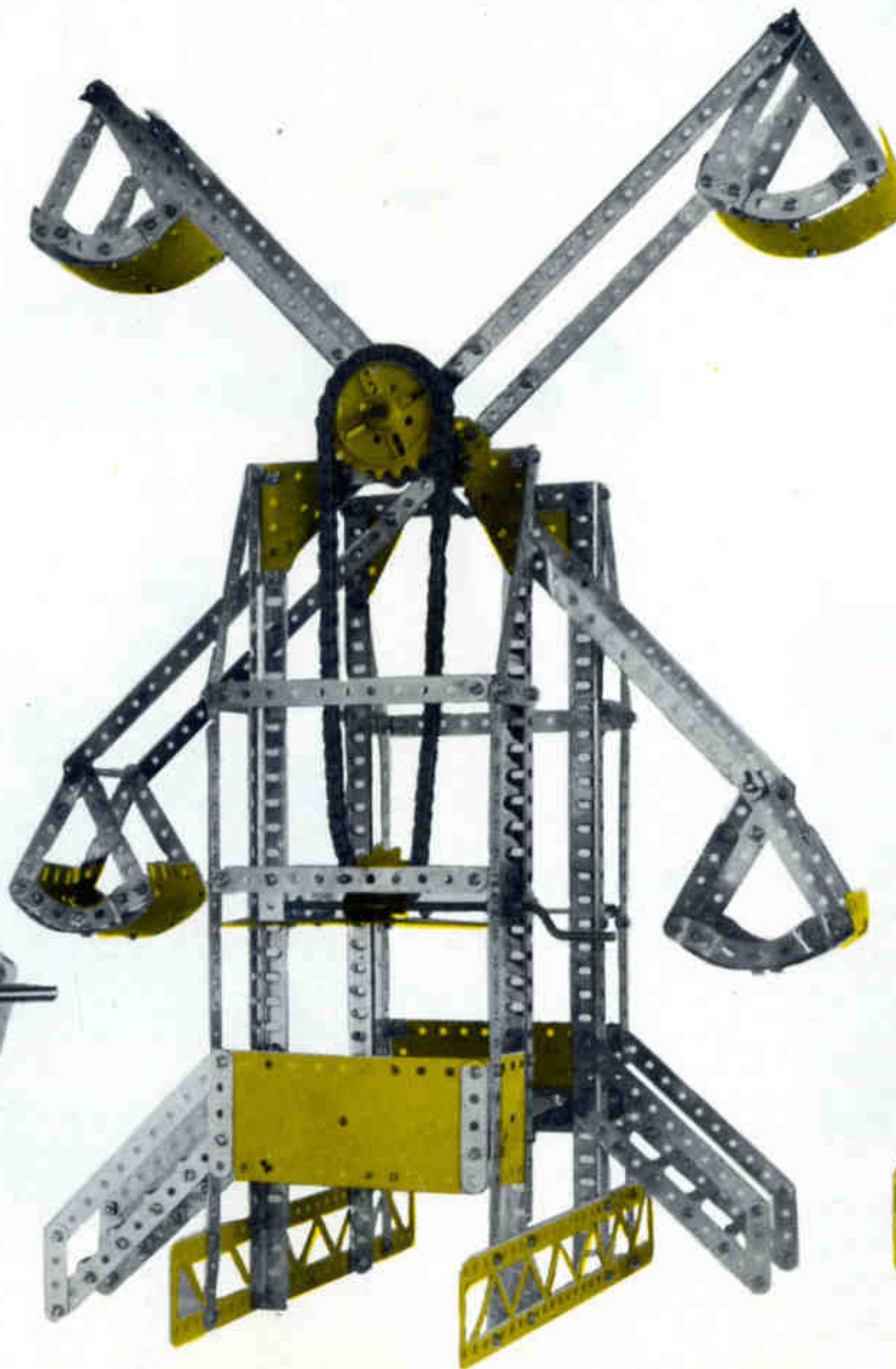

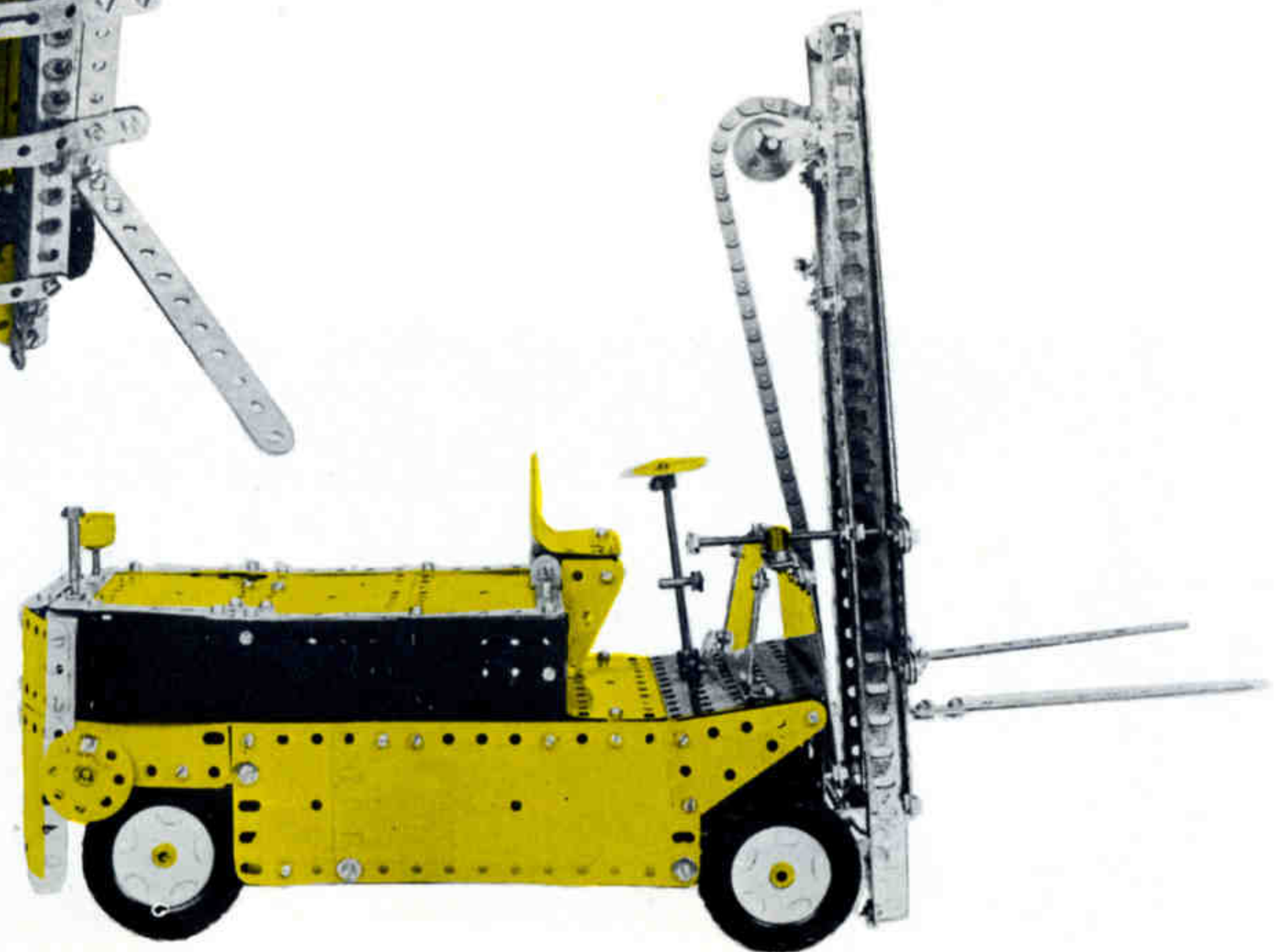
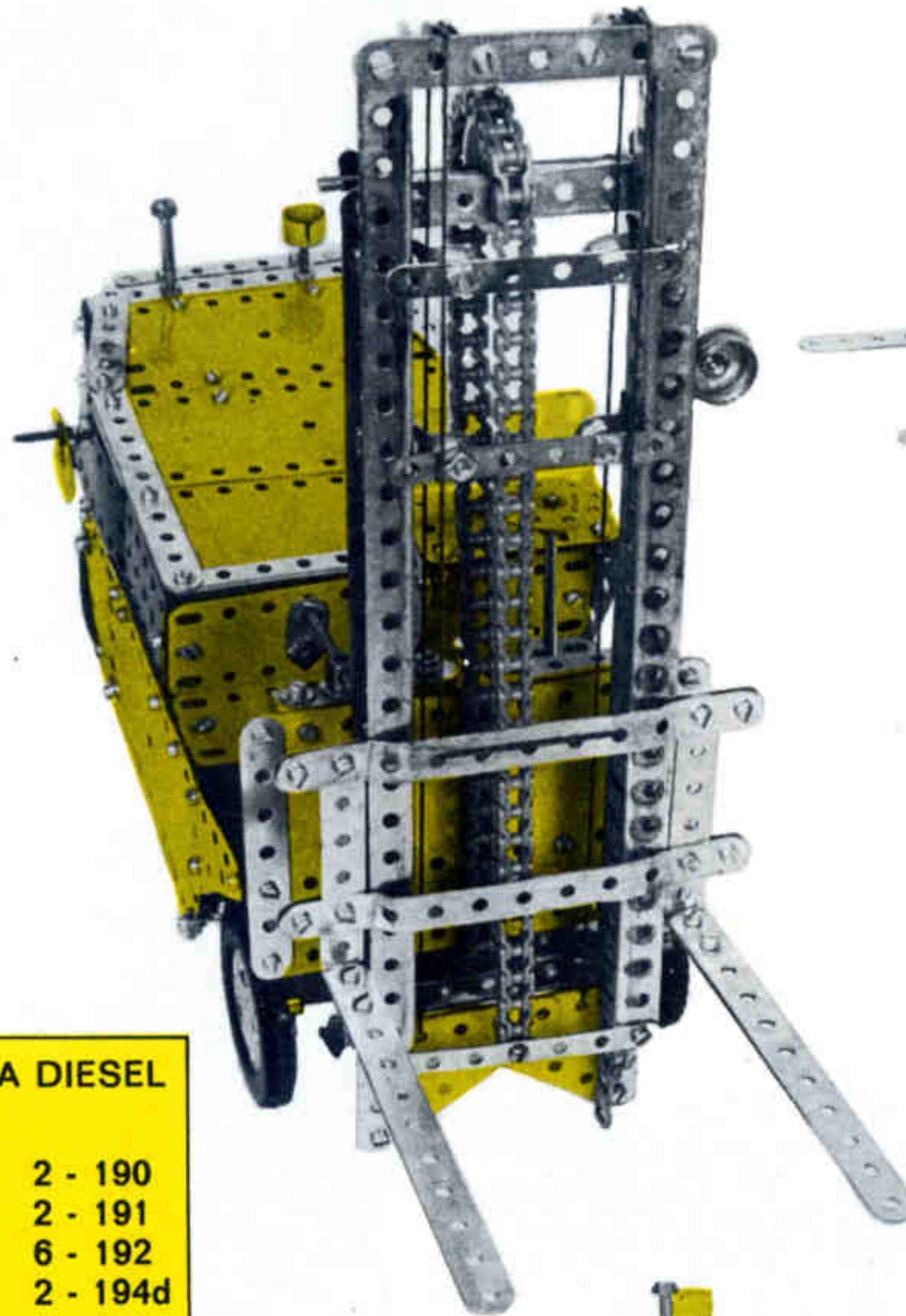

**CARRETILLA ELEVADORA HIDRAULICA DIESEL**

8 / 299

18 - 2	1 - 15b	32 - 38	2 - 111	2 - 190
6 - 3	3 - 16	1 - 40	2 - 111a	2 - 191
2 - 4	1 - 17	1 - 45	6 - 111c	6 - 192
10 - 5	2 - 18a	1 - 46	2 - 115	2 - 194d
4 - 6	1 - 20b	1 - 48	4 - 125	1 - 199
4 - 6a	1 - 22a	5 - 48a	1 - 126	4 - 221
7 - 8	1 - 23	2 - 48b	2 - 126a	2 - 222
6 - 10	1 - 23a	1 - 51	1 - 147b	3 - 235a
2 - 11	2 - 24	2 - 52	1 - 155	4 - 235b
17 - 12	1 - 26	2 - 53	1 - 164	70 - 374
2 - 12a	1 - 27a	6 - 59	1 - 176	
2 - 12c	8 - 35	2 - 62	4 - 187	
2 - 15	197 - 37a	1 - 80c	2 - 188	
1 - 15a	163 - 37b	1 - 91	4 - 189	

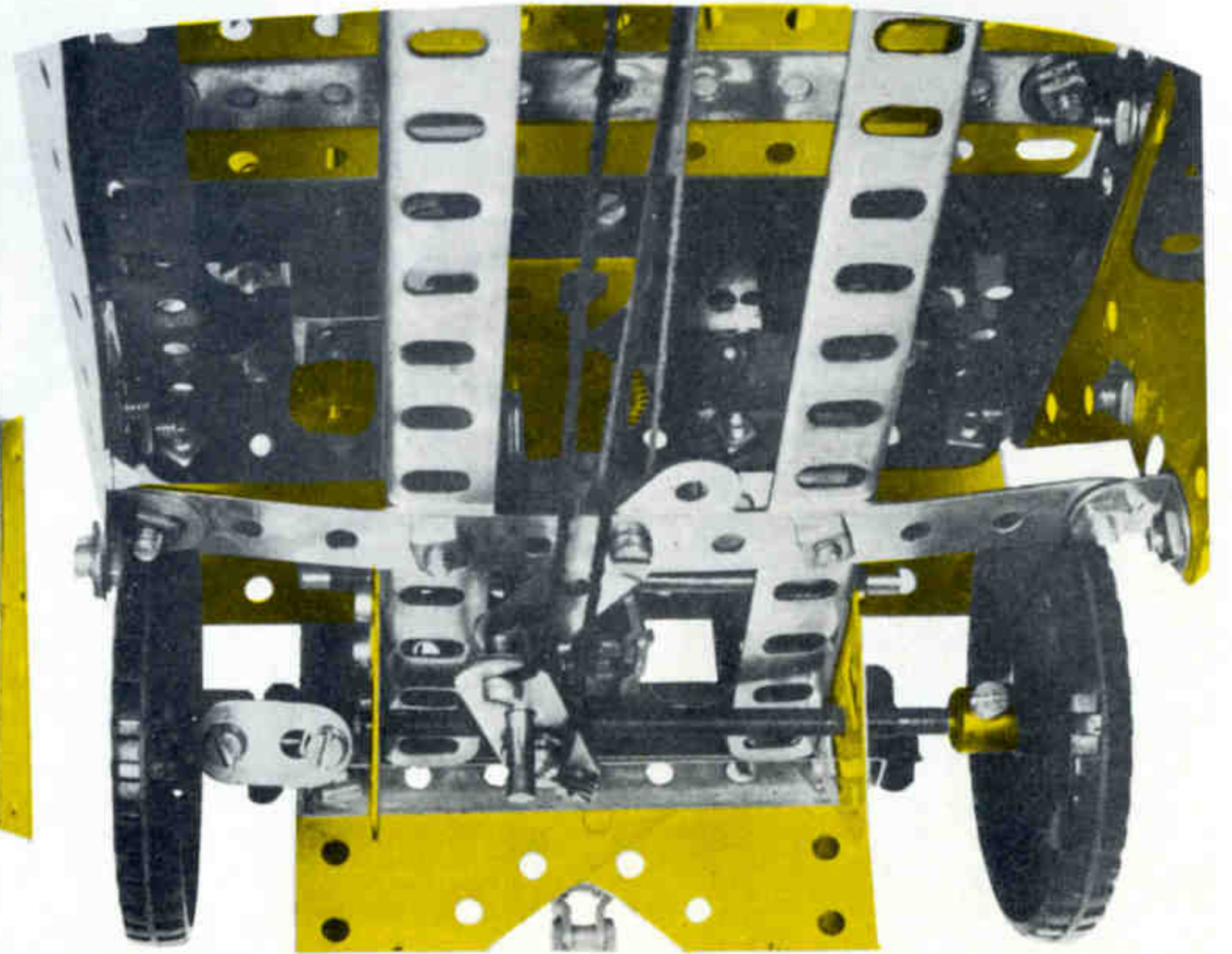
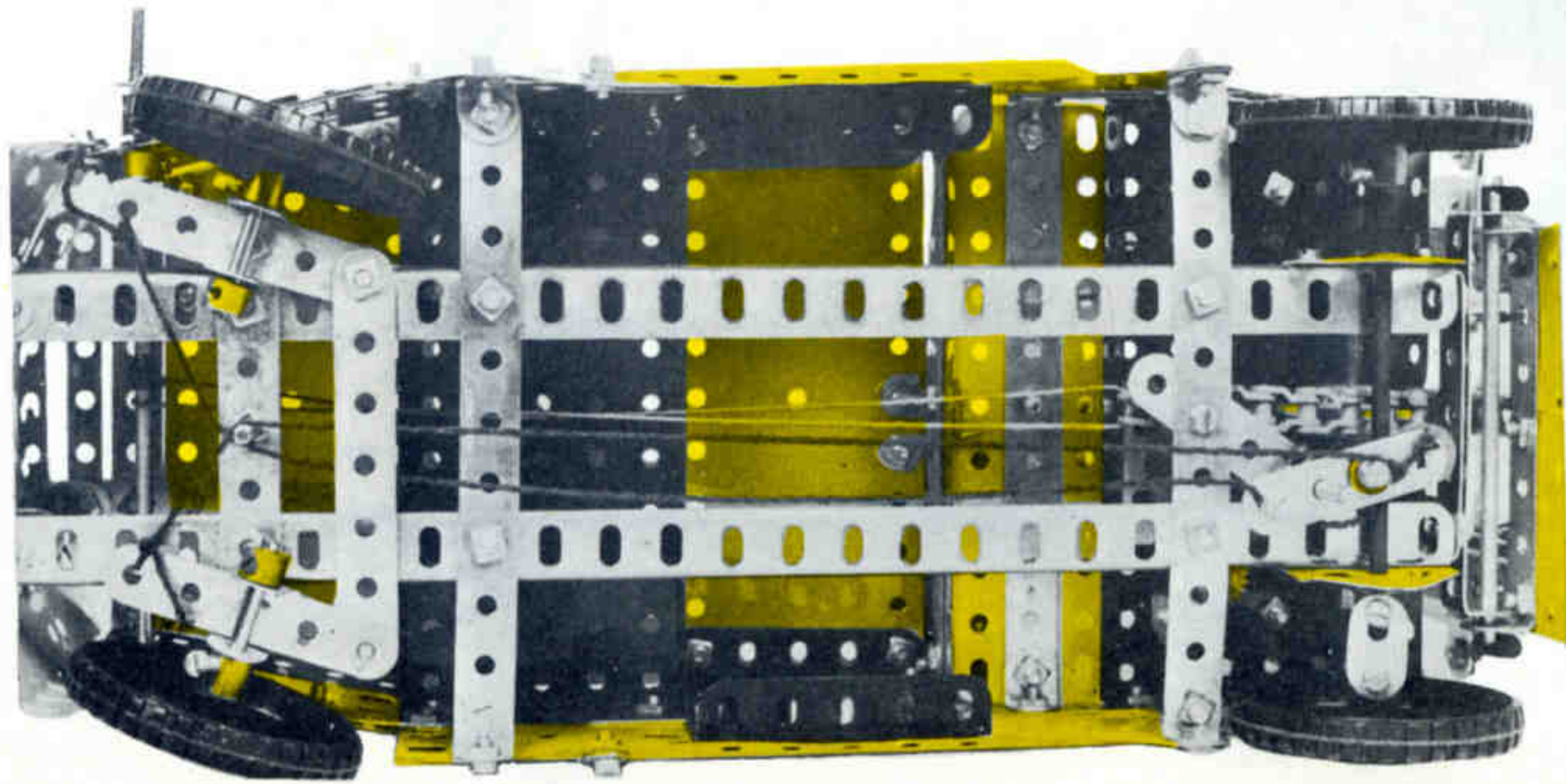
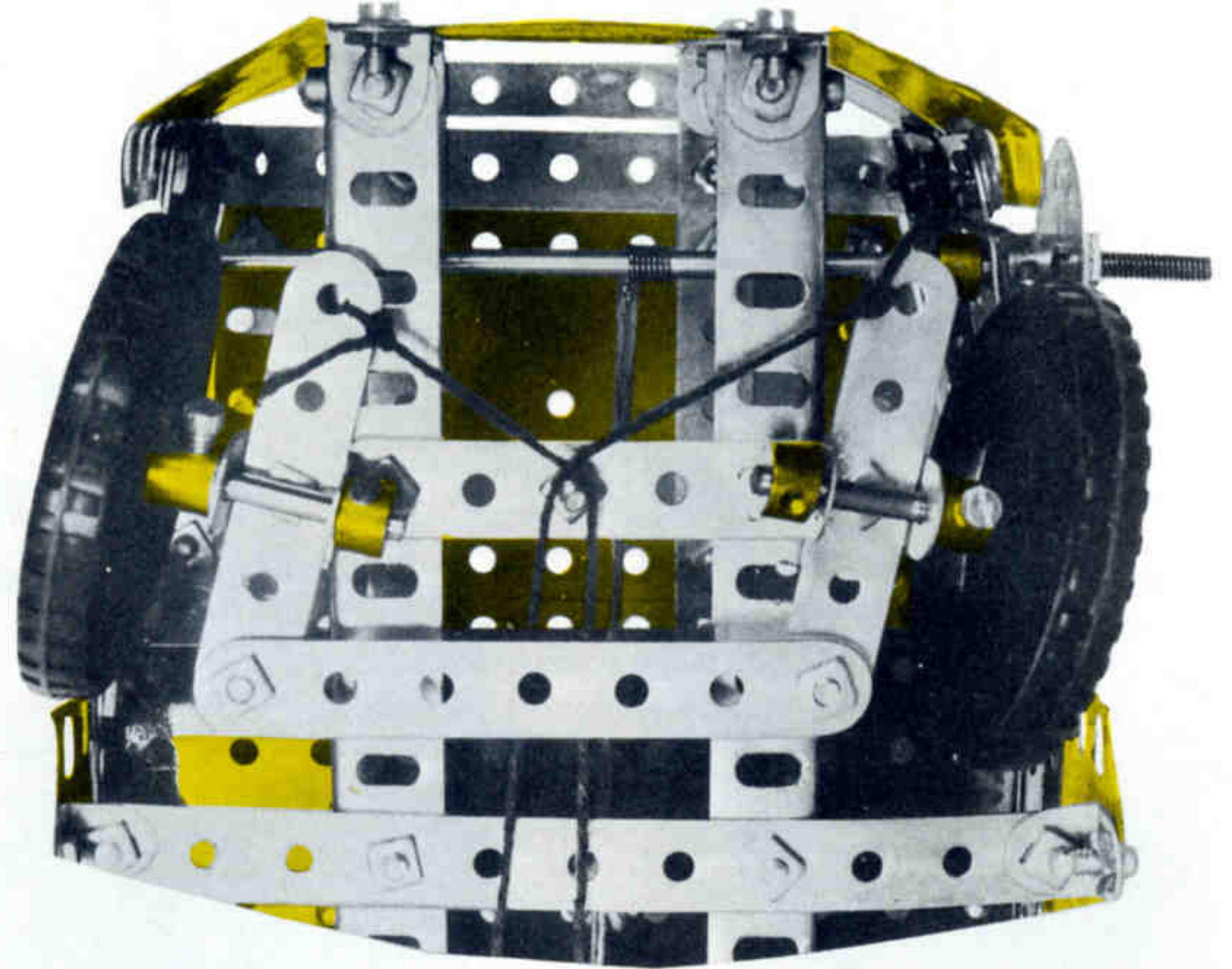
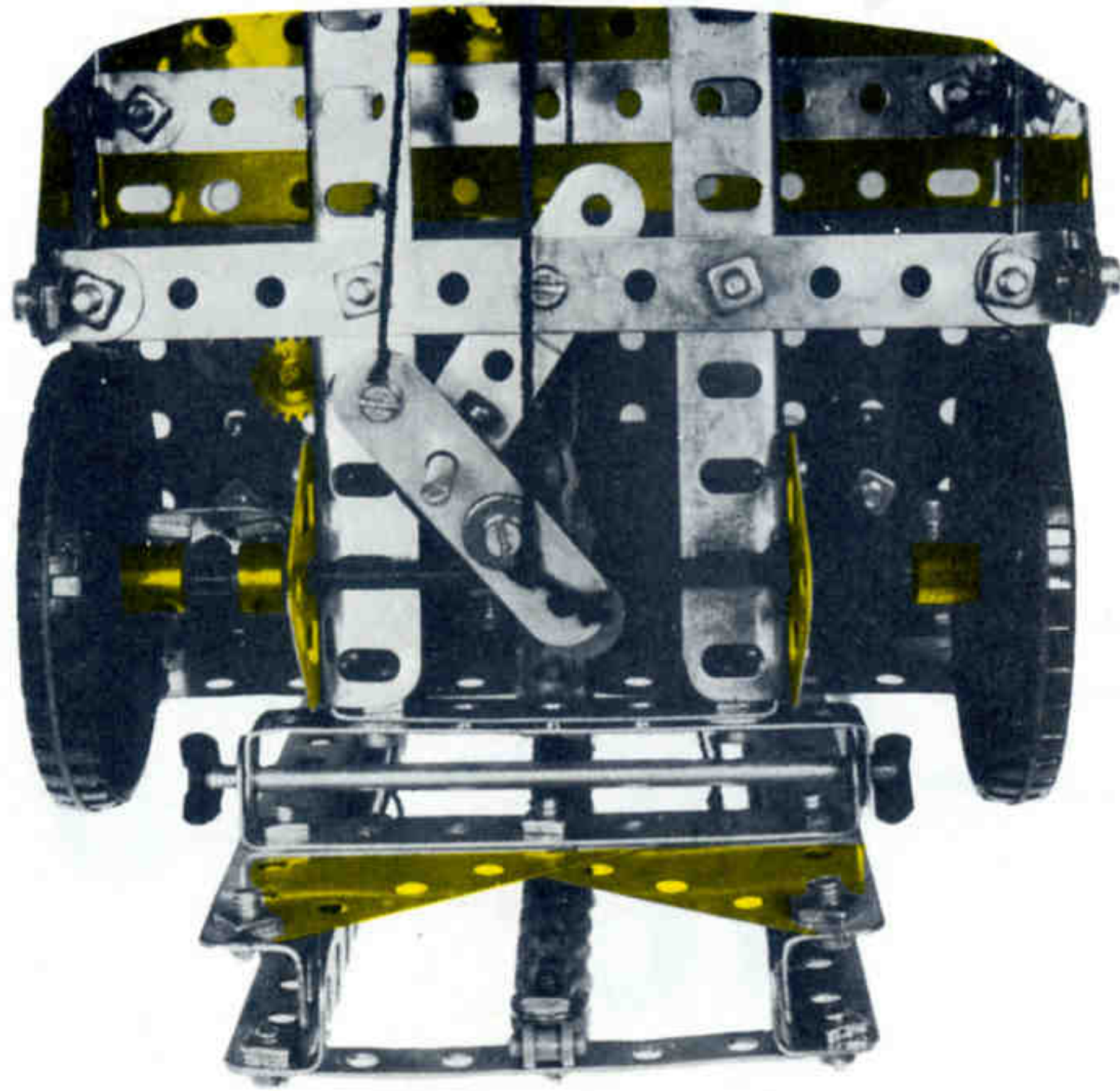



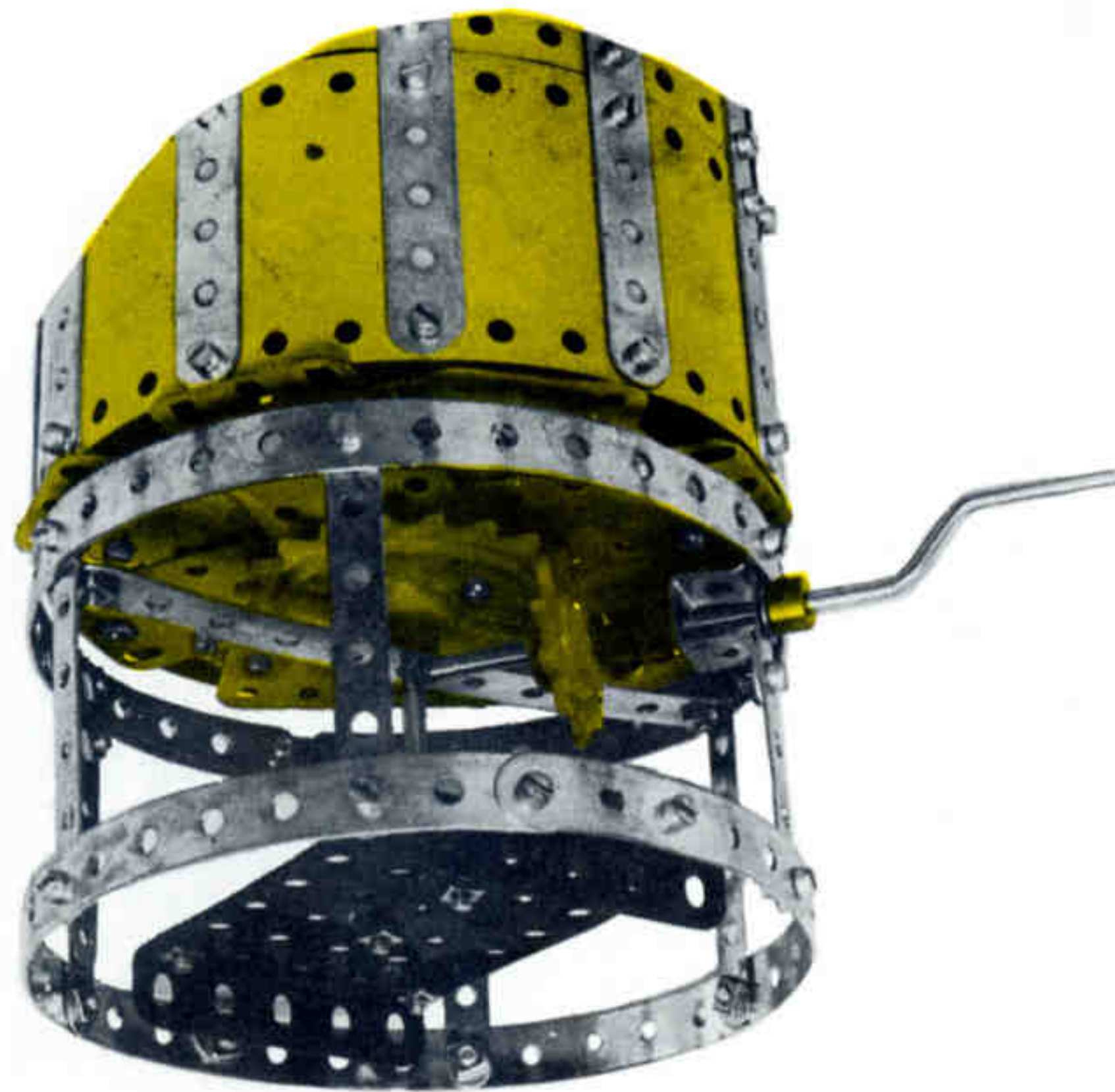

**SATELITE DE COMUNICACIONES  
INTELSAT IV TIPO SYNCOM 8/301**

2 - 1	1 - 19	2 - 62	2 - 194
18 - 2	1 - 20a	1 - 63	2 - 194a
6 - 3	4 - 20b	2 - 80c	2 - 194d
2 - 4	1 - 24	8 - 90a	2 - 197
12 - 5	1 - 32	1 - 91	2 - 214
2 - 10	2 - 35	1 - 92	4 - 221
10 - 12	190 - 37a	2 - 111a	4 - 235
2 - 12a	180 - 37b	6 - 188	4 - 235a
1 - 13	14 - 38	4 - 189	2 - 235b
1 - 15	1 - 45	4 - 190	
2 - 17	1 - 53	2 - 191	
2 - 19b	3 - 59	6 - 192	

**INSTRUMENTO  
AGRICOLA 8/300**

4 - 5	1 - 24	1 - 91
4 - 10	16 - 37a	1 - 92
4 - 12	15 - 37b	1 - 111a
1 - 15	16 - 38	2 - 111c
2 - 16	1 - 46	1 - 155
1 - 17	2 - 48a	2 - 235
2 - 19b	1 - 59	1 - 235b
1 - 22	1 - 63	

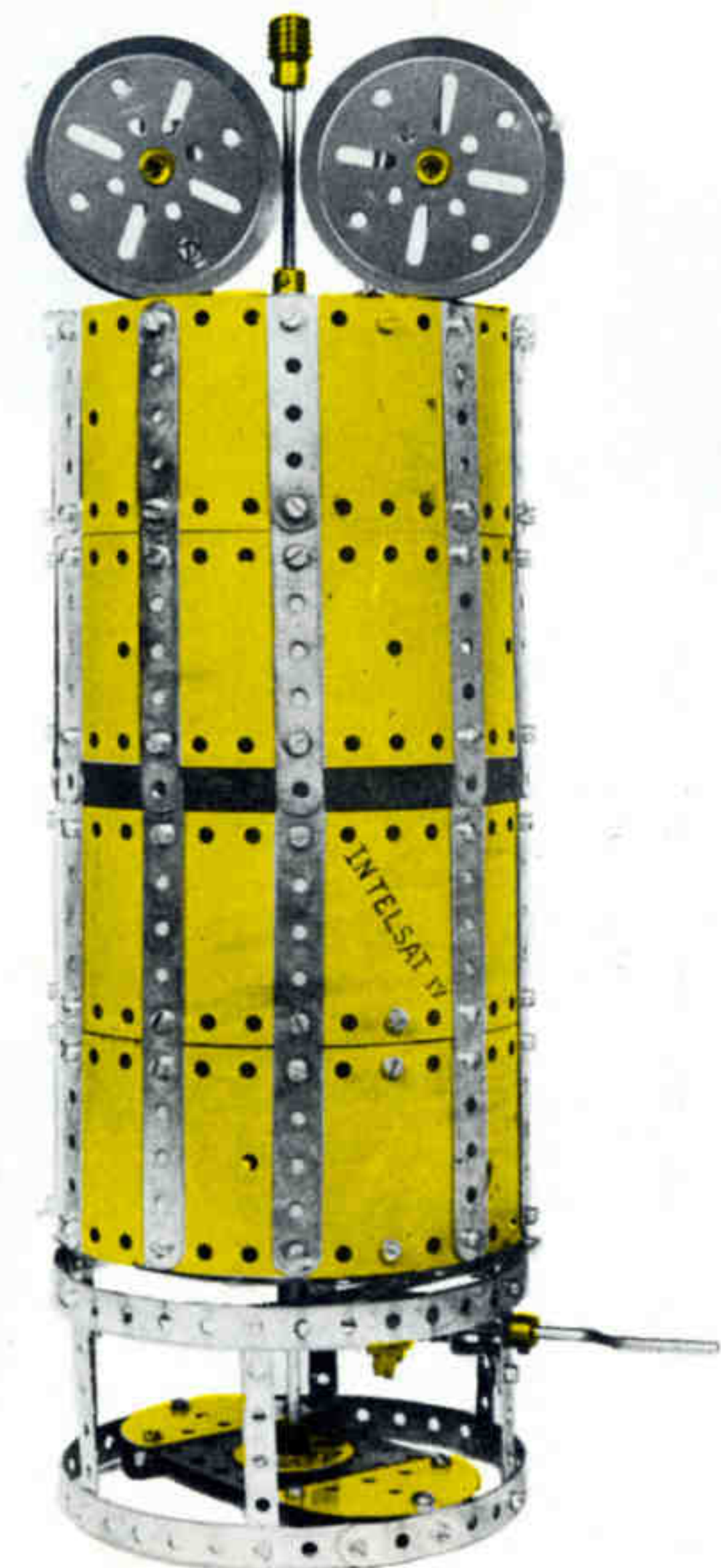
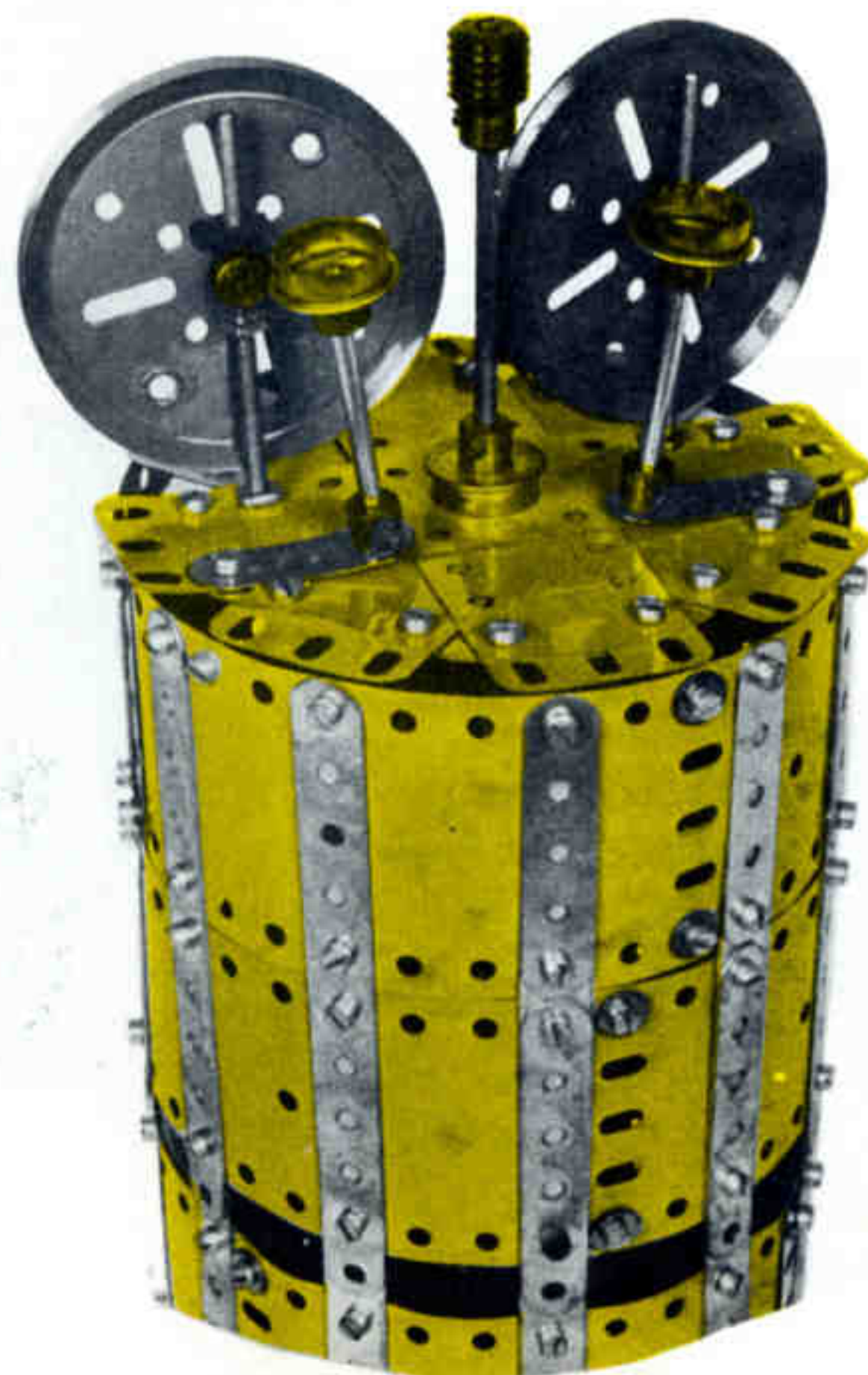
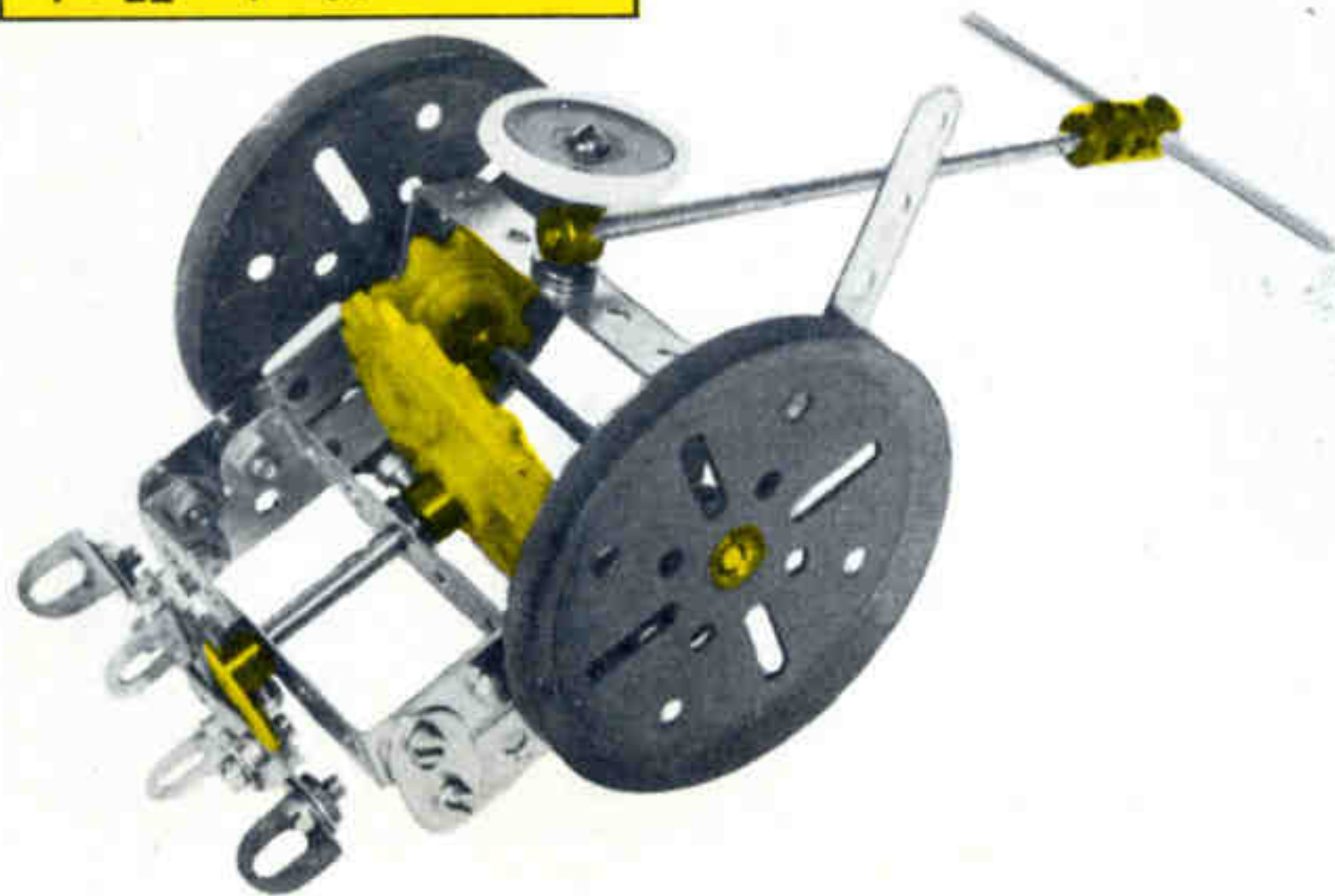

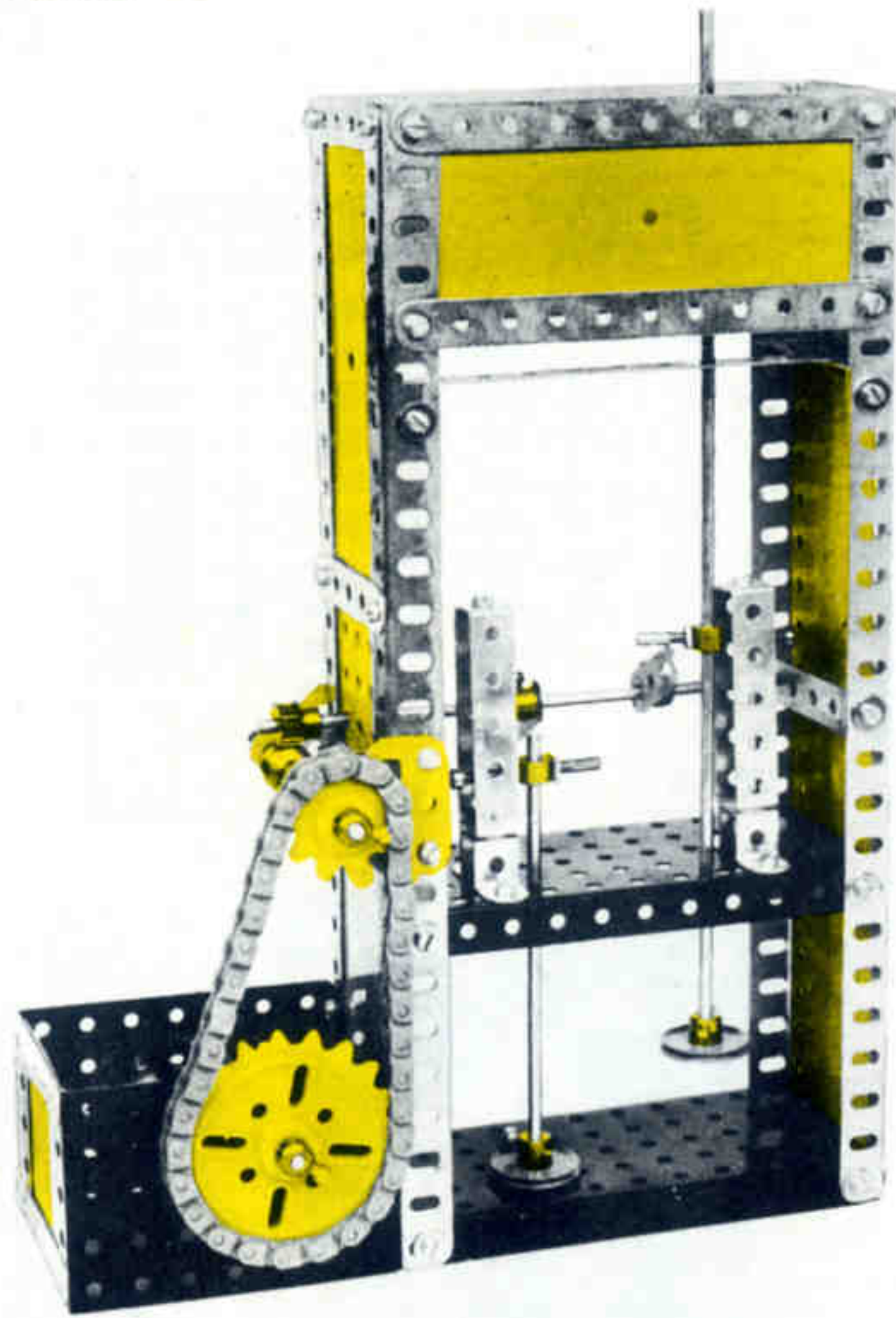

**MARTILLOS  
DE FORJA 8/302**

5 - 2	7 - 48a
7 - 5	2 - 52
4 - 8	2 - 53
1 - 13	1 - 53a
1 - 14	6 - 59
2 - 15	2 - 62
2 - 15b	1 - 91
1 - 19	1 - 92
2 - 22	2 - 111
1 - 23a	2 - 115
2 - 26	2 - 126a
1 - 27a	1 - 190
1 - 32	4 - 192
54 - 37a	1 - 197
54 - 37b	1 - 213
21 - 38	34 - 374
2 - 45	

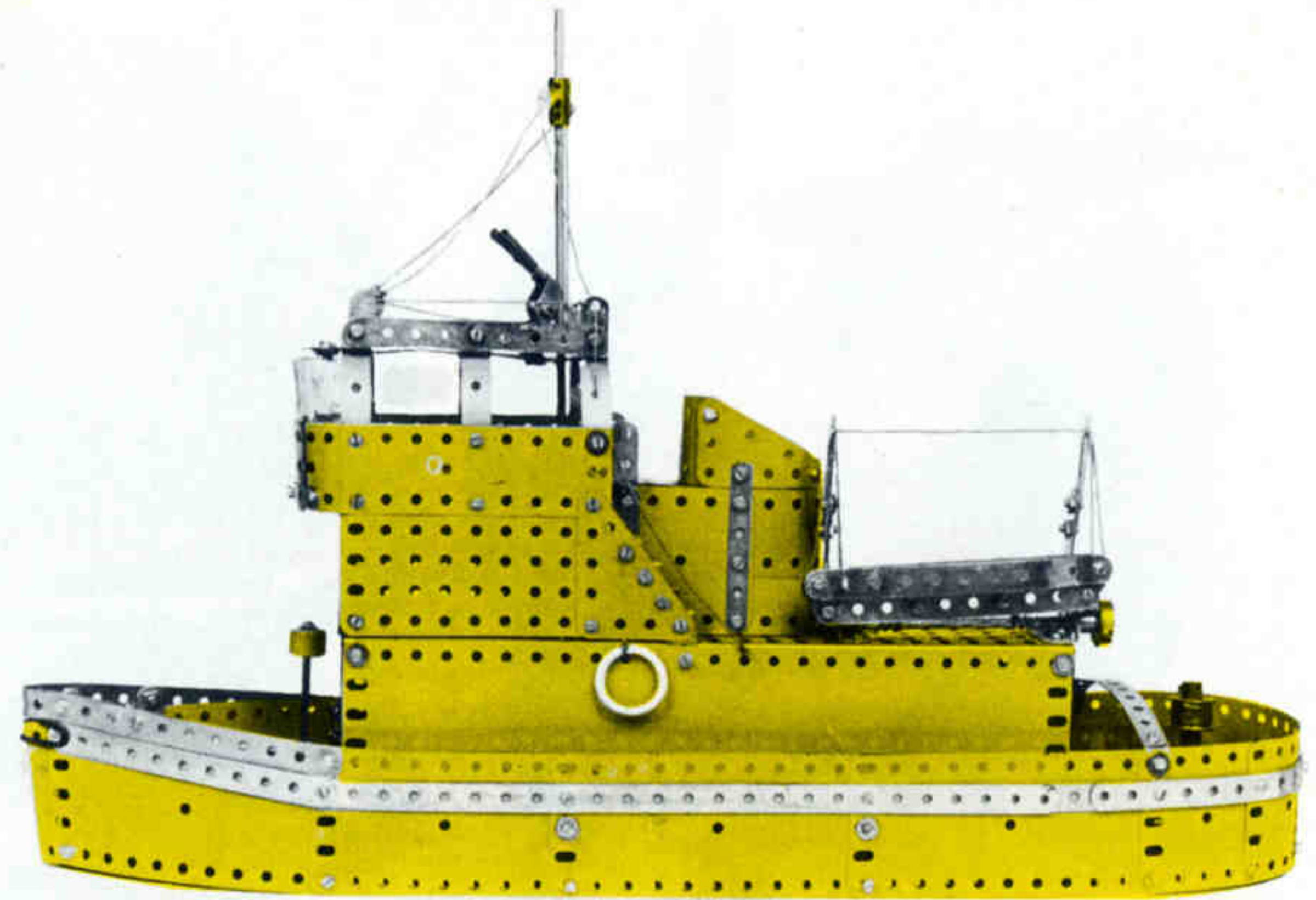
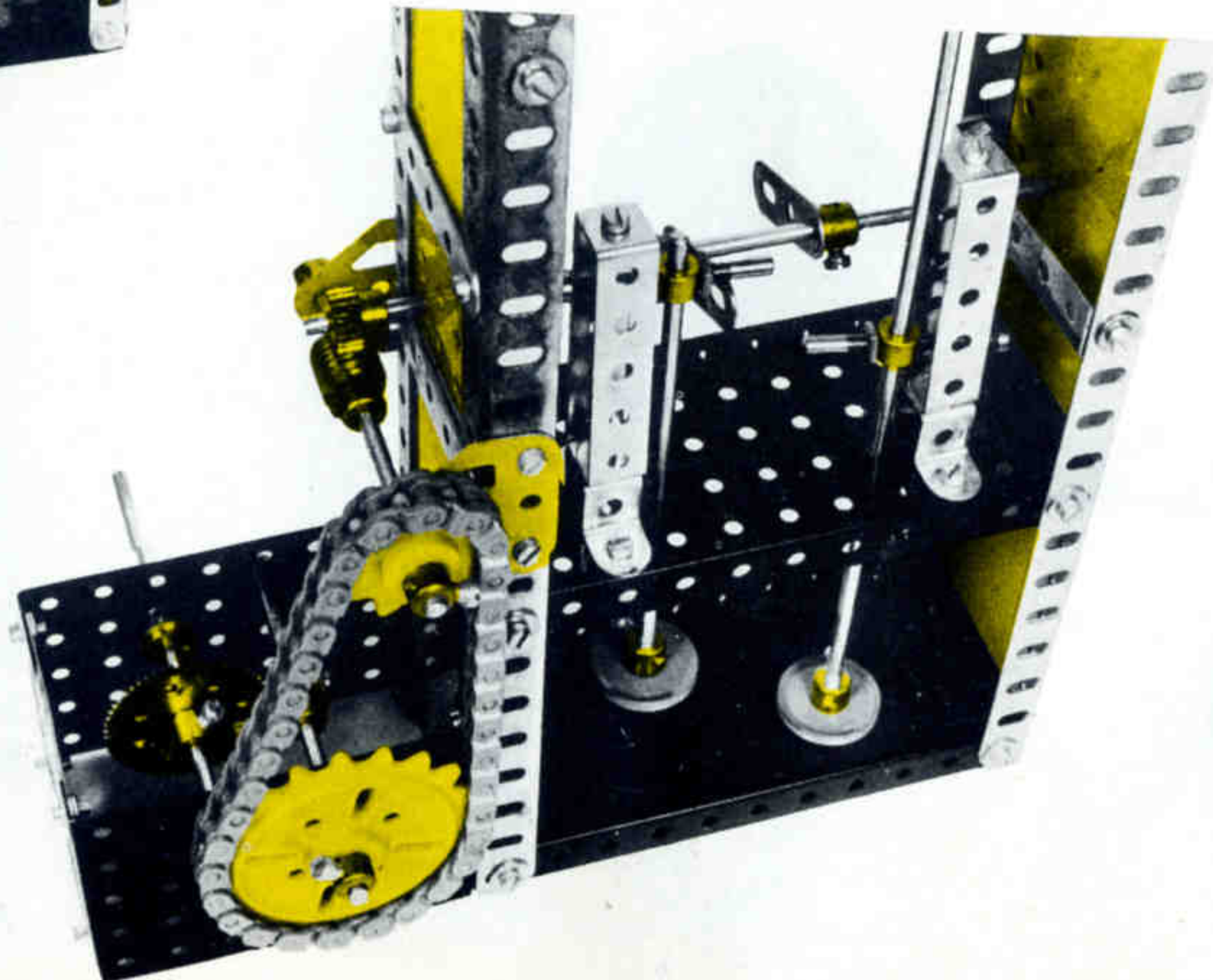

**REMOLCADOR (DE PUERTO)  
8/303**

12 - 1	1 - 40	1 - 186
14 - 2	2 - 45	2 - 188
6 - 3	1 - 46	4 - 189
13 - 5	2 - 48	8 - 190
4 - 8	4 - 48a	2 - 191
12 - 10	2 - 48b	6 - 192
4 - 11	1 - 51	1 - 193d
1 - 11a	2 - 52	1 - 194
12 - 12	3 - 53	2 - 194a
2 - 12a	2 - 53a	1 - 194c
2 - 12c	2 - 54	2 - 194d
1 - 13	4 - 59	2 - 197
1 - 15	1 - 63	1 - 199
2 - 17	1 - 80c	1 - 200
4 - 18a	2 - 90	2 - 212
1 - 18b	4 - 90a	2 - 212a
3 - 20b	5 - 111c	2 - 213
1 - 23a	2 - 115	2 - 214
2 - 24	2 - 126	6 - 215
1 - 26	1 - 126a	4 - 221
205 - 37a	2 - 155	2 - 222
191 - 37b	1 - 164	4 - 235a
19 - 38	2 - 176	3 - 235b

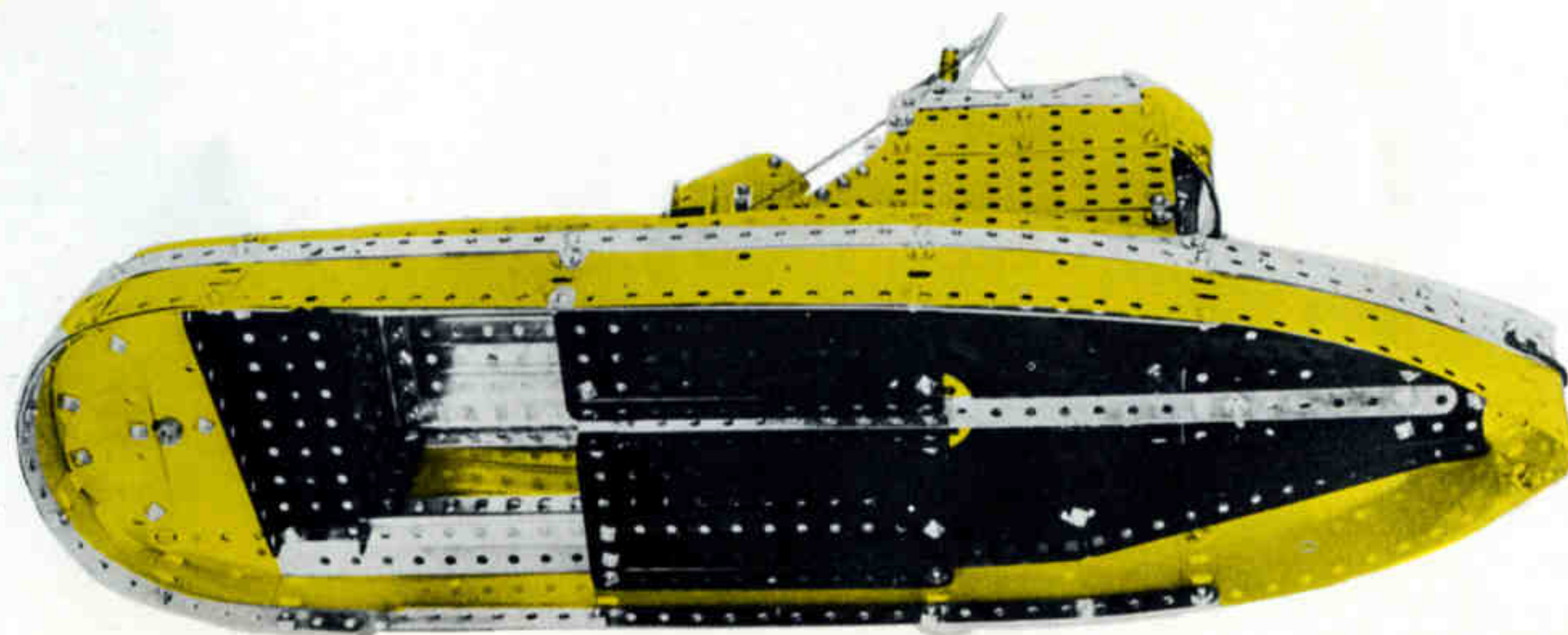
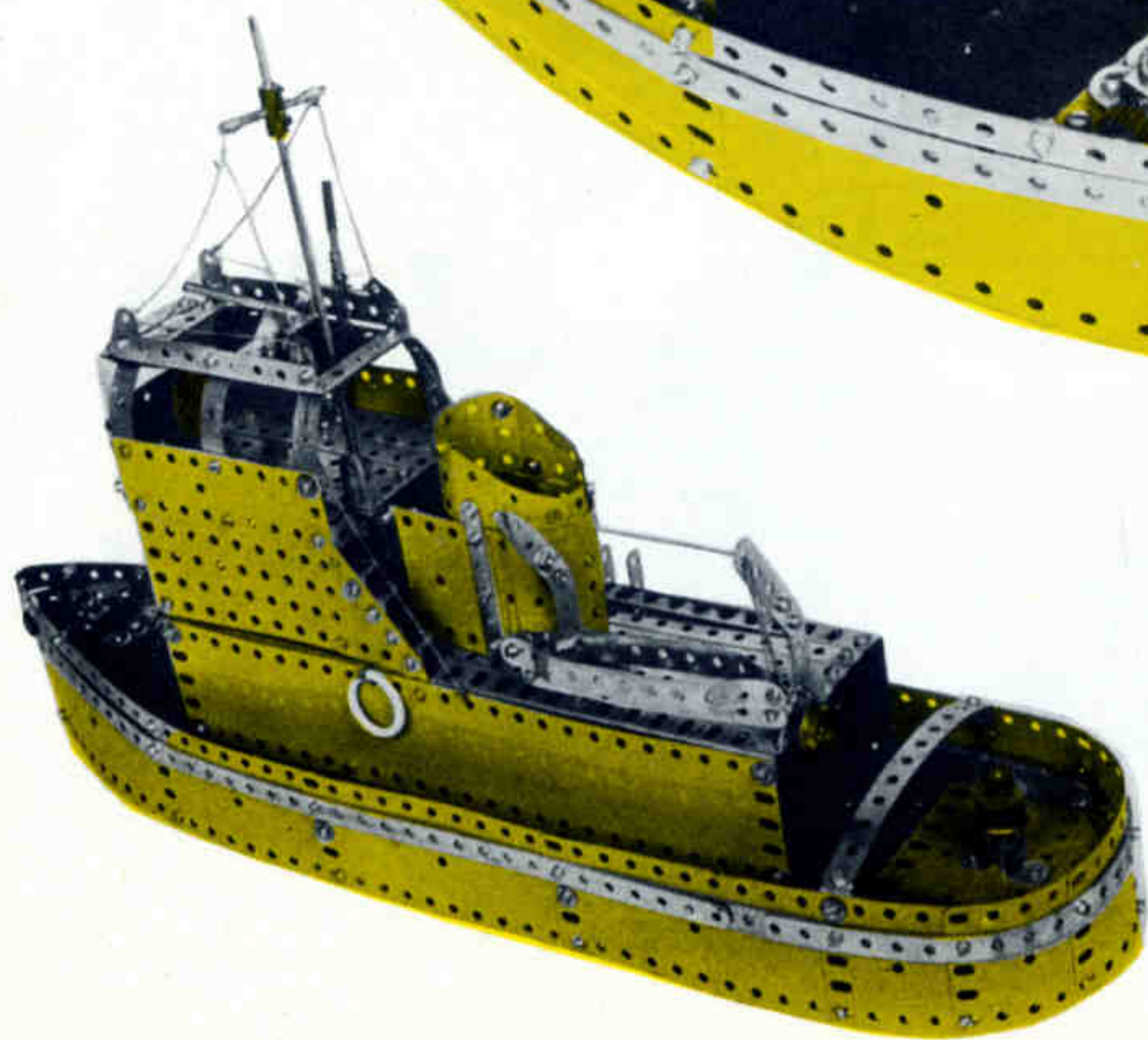
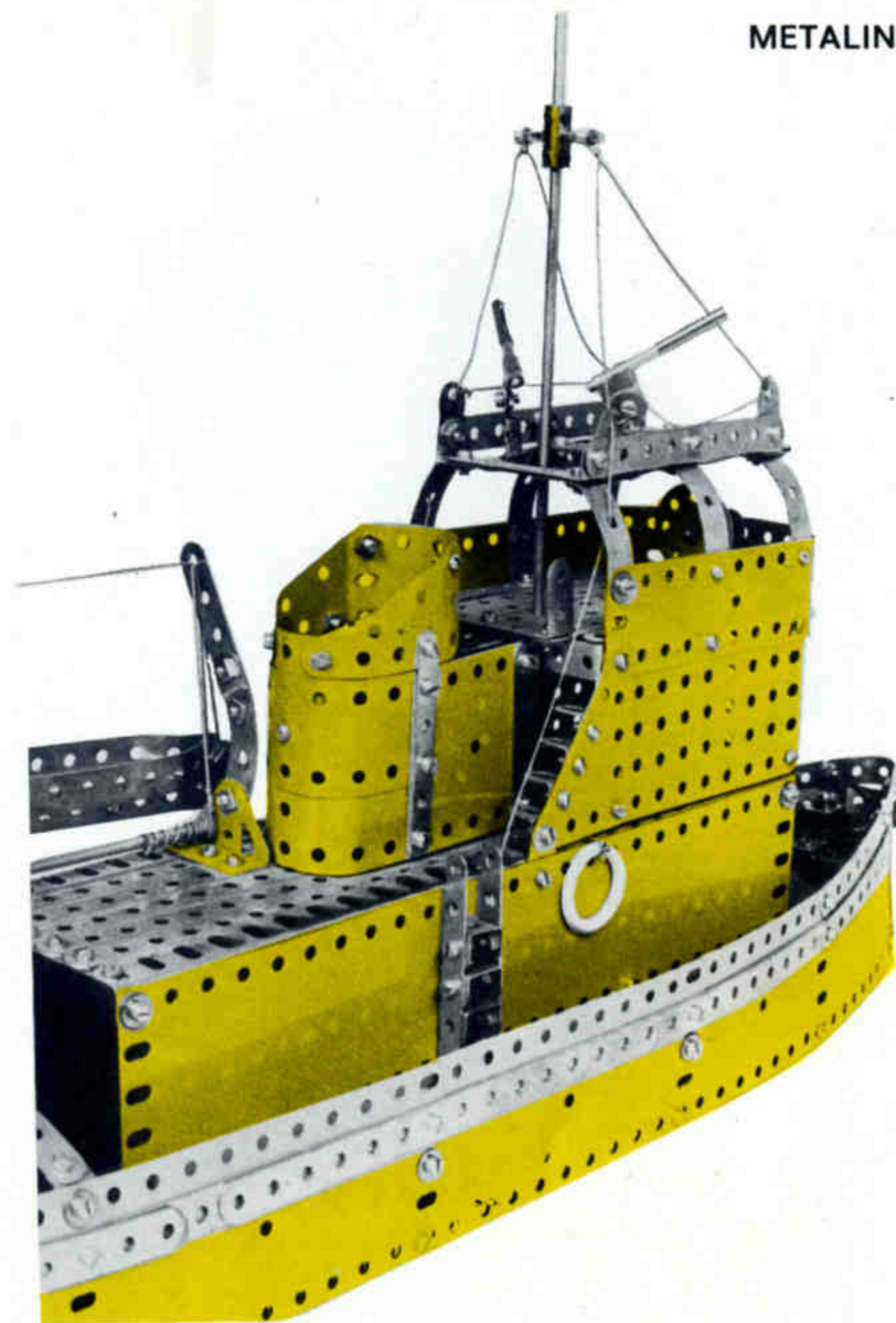
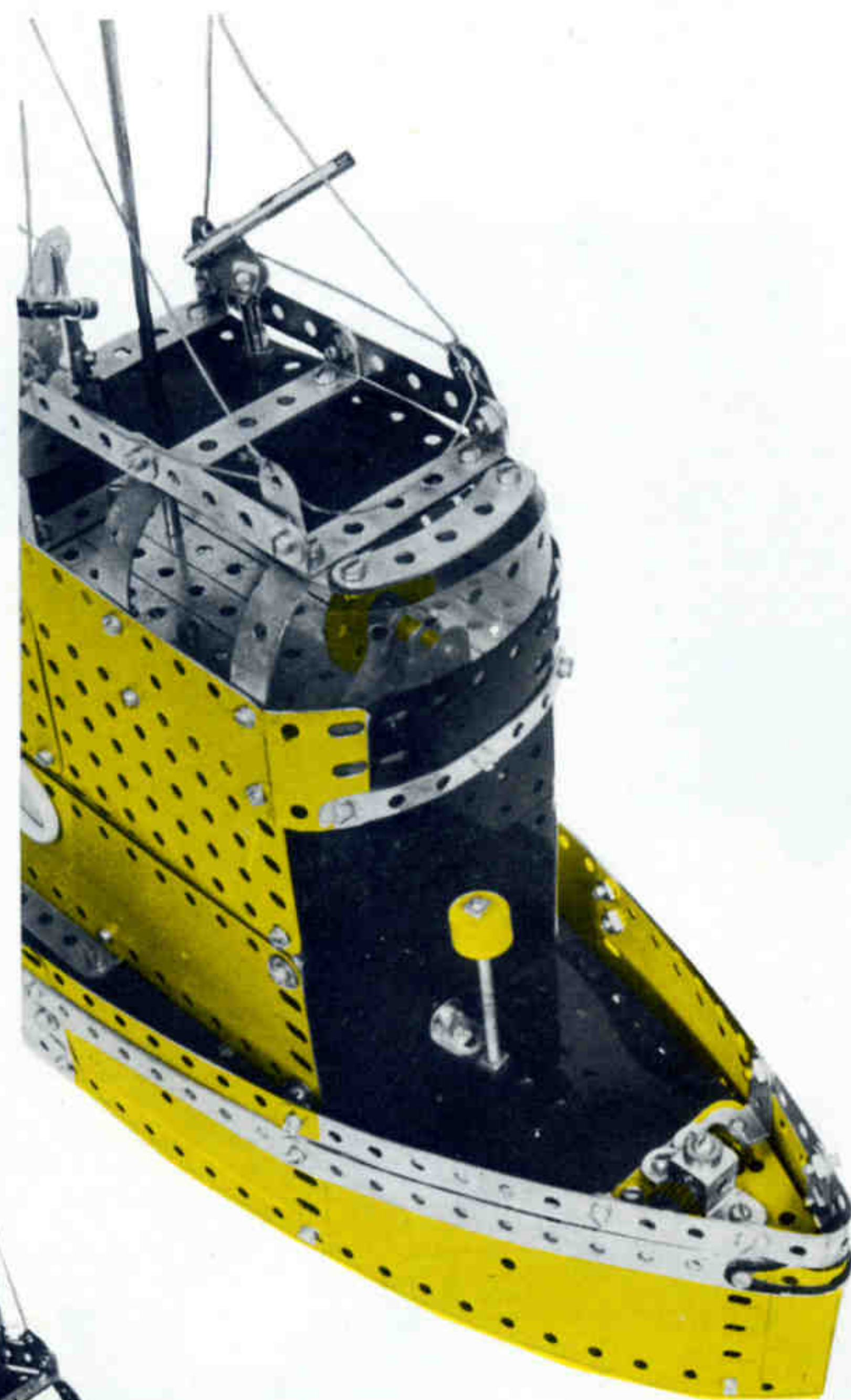

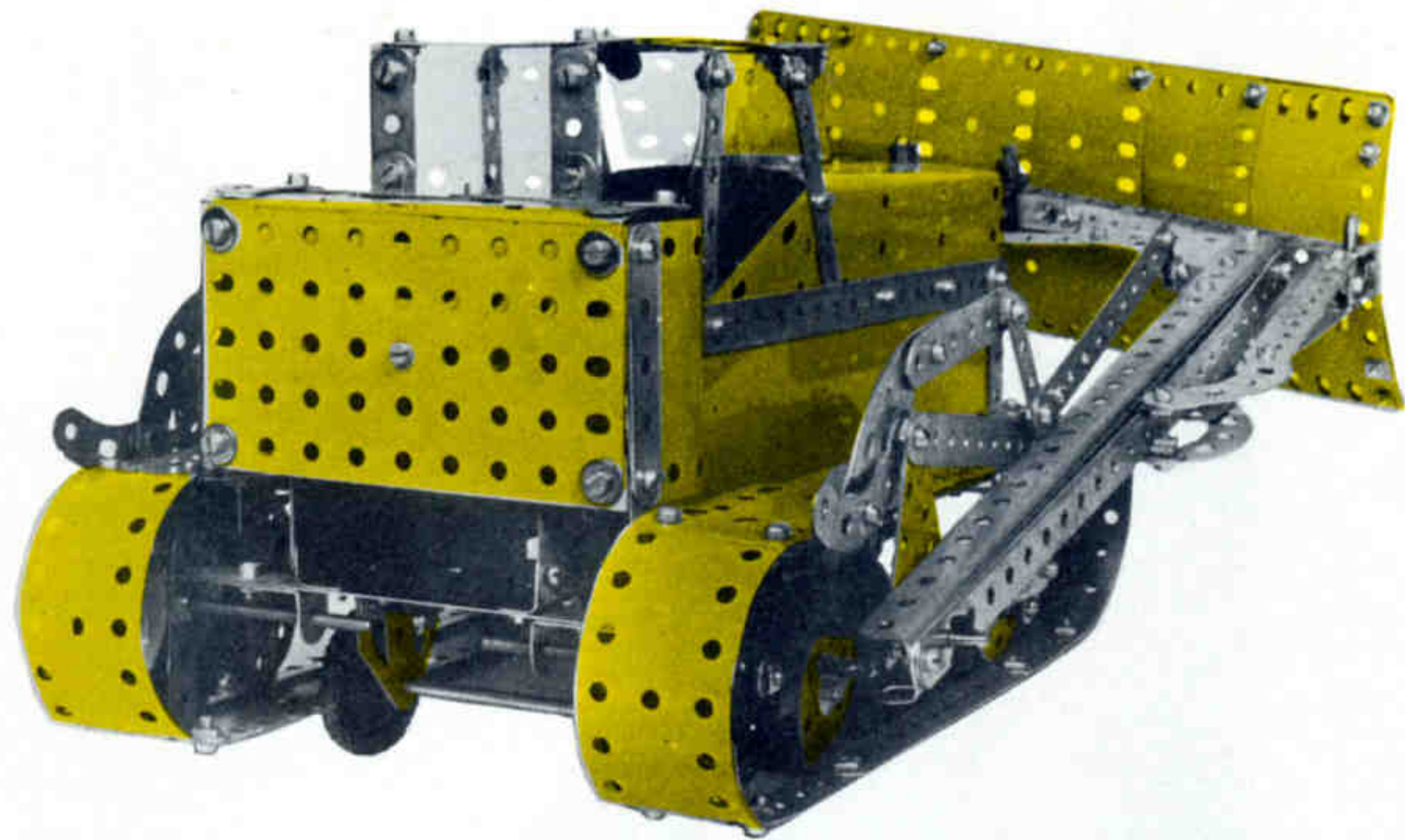
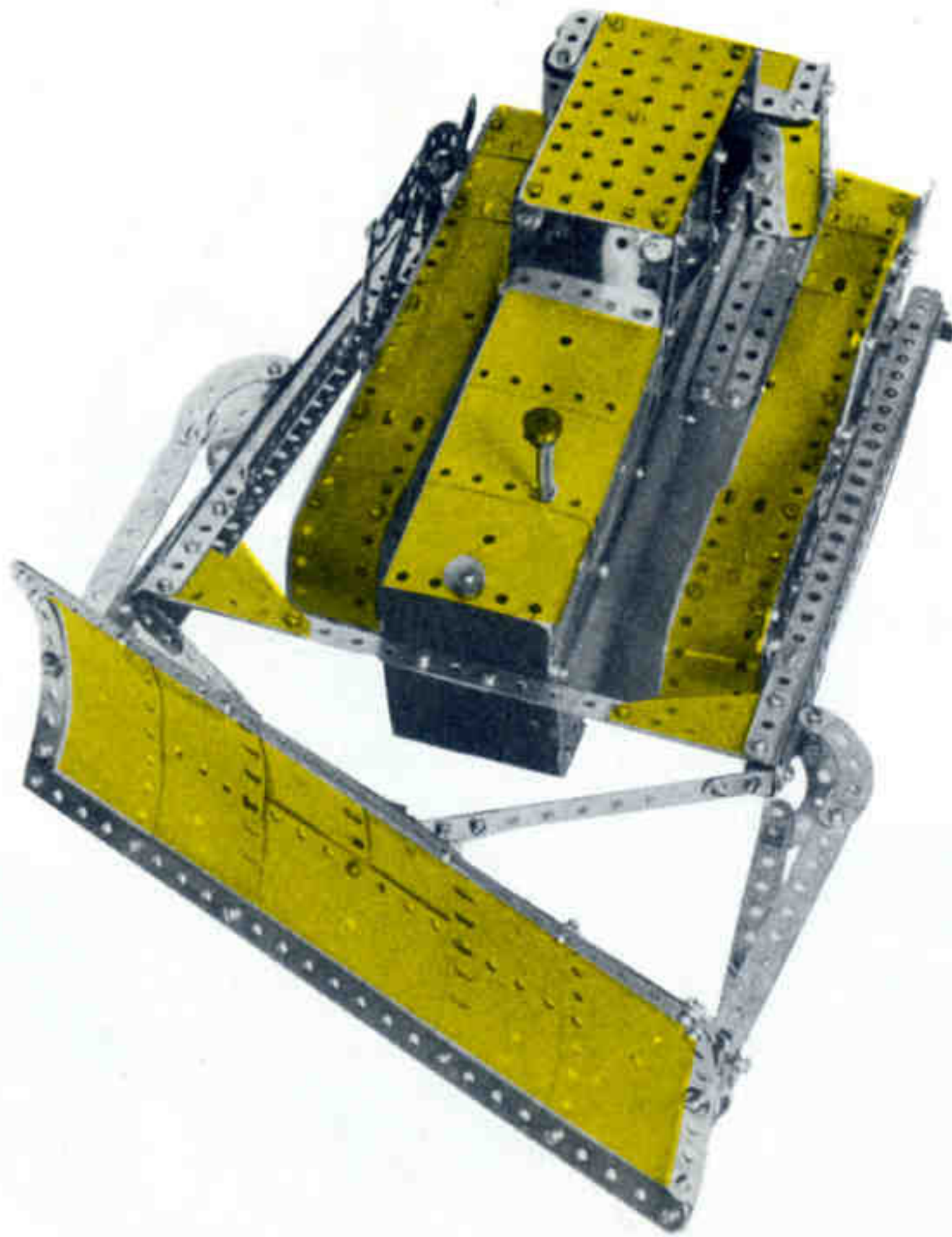

BULLDOZER 8,304				
8 - 1	2 - 15b	2 - 48	2 - 115	2 - 197
18 - 2	2 - 16	10 - 48a	4 - 125	1 - 199
5 - 3	1 - 17	2 - 48b	2 - 126	1 - 200
2 - 4	4 - 18a	1 - 51	3 - 126a	2 - 212
13 - 5	4 - 22	2 - 53	4 - 142c	2 - 212a
4 - 6	1 - 23a	2 - 53a	4 - 187	2 - 213
4 - 6a	2 - 24	4 - 59	6 - 188	1 - 215
7 - 8	2 - 24c	2 - 62	4 - 189	4 - 221
12 - 10	2 - 26	1 - 63	8 - 190	2 - 222
4 - 11	223 - 37a	2 - 80c	2 - 191	2 - 223
1 - 11a	198 - 37b	2 - 90	6 - 192	4 - 235
18 - 12	26 - 38	8 - 90a	2 - 193	4 - 235a
4 - 12a	2 - 38d	2 - 111	2 - 193a	2 - 235b
6 - 12c	1 - 45	2 - 111a	2 - 194	
2 - 15	1 - 46	5 - 111c	2 - 194d	

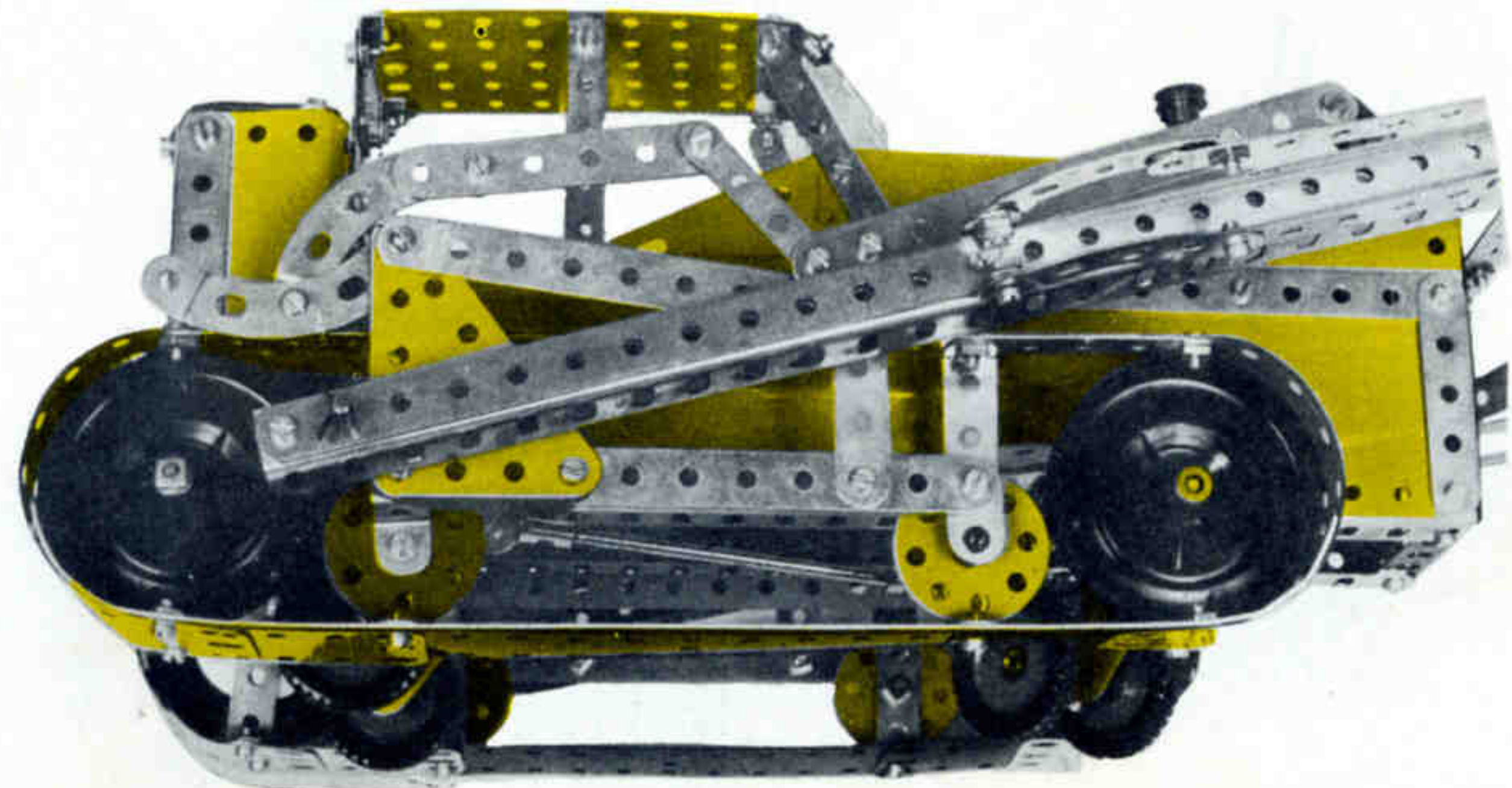

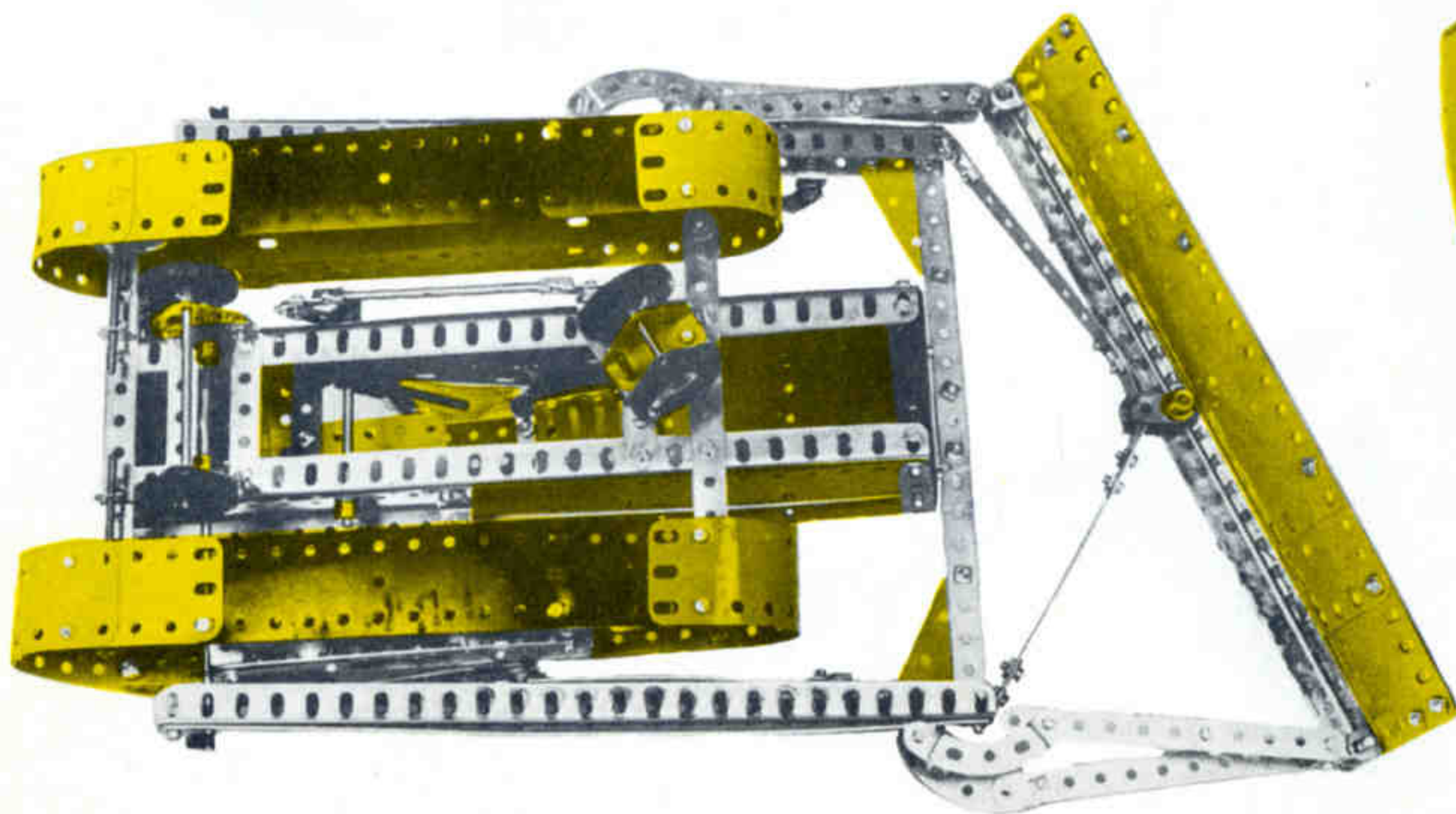
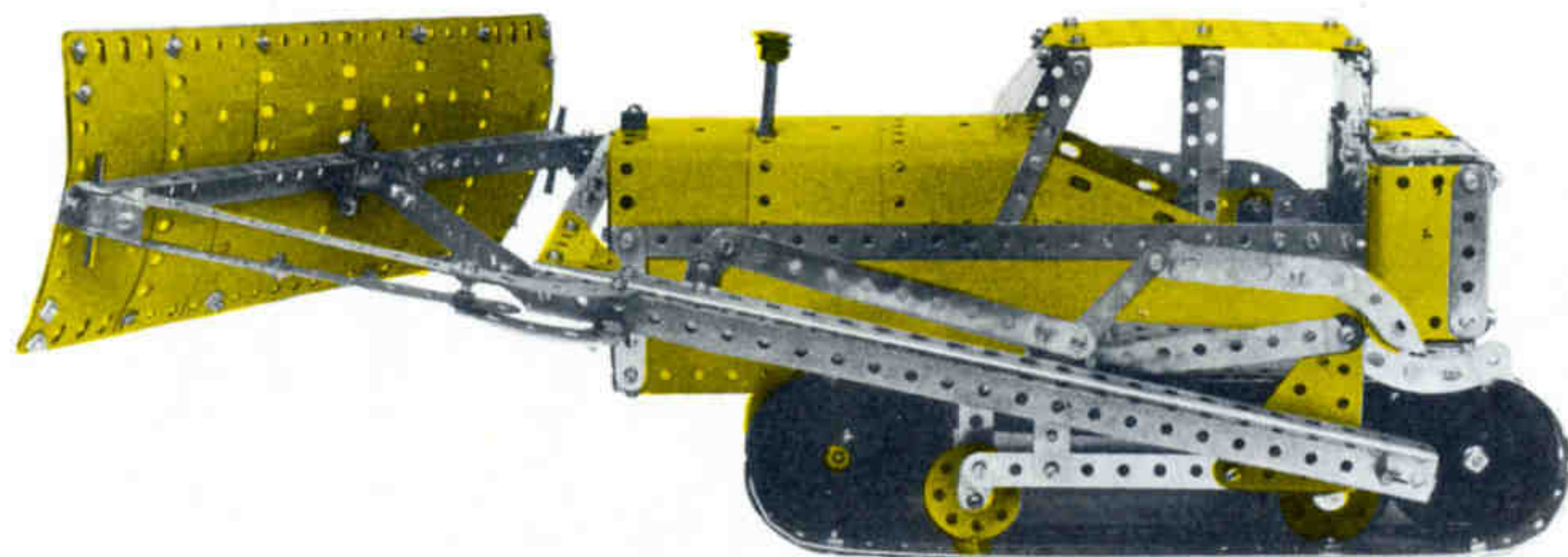

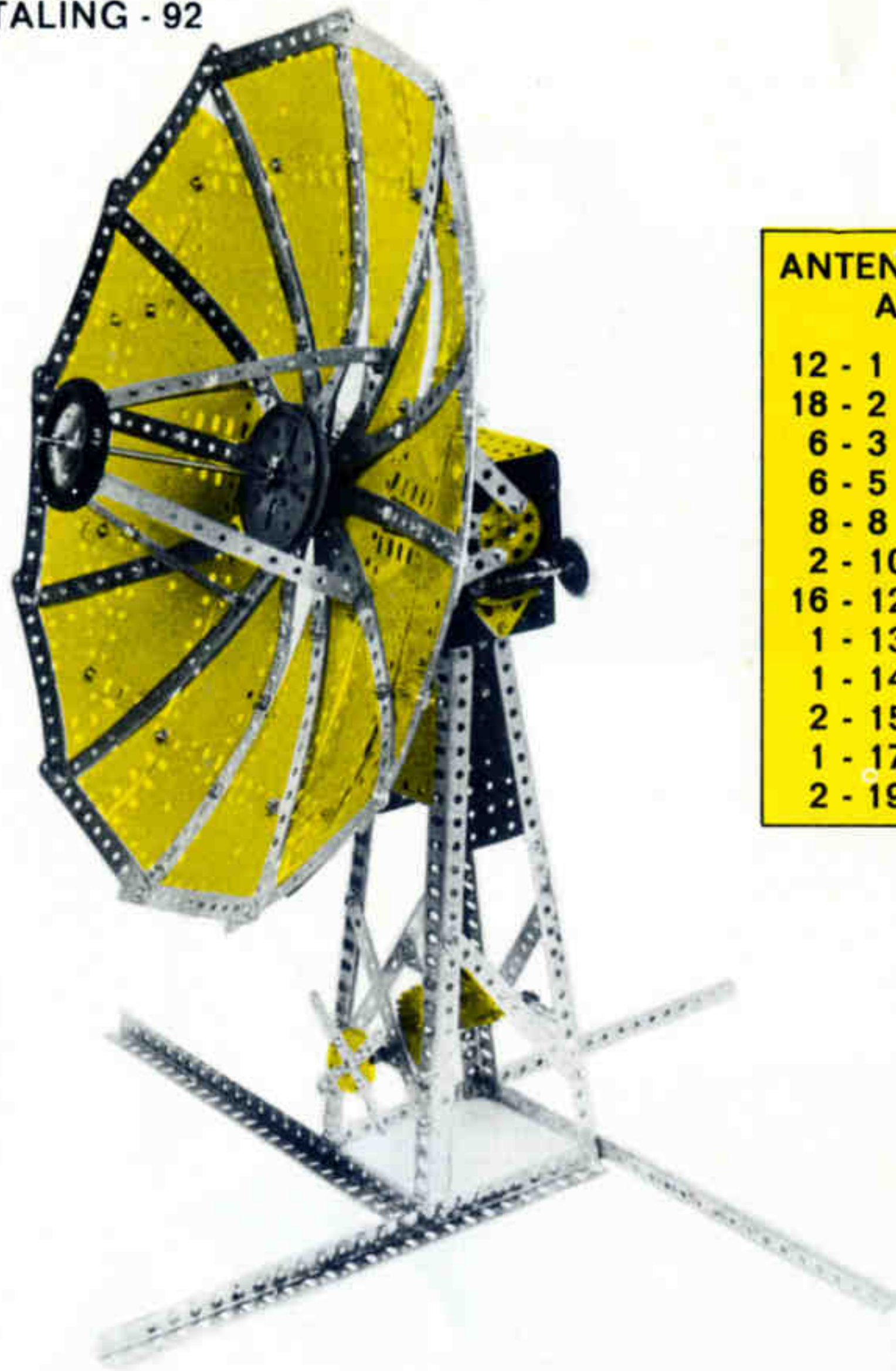

**ANTENA DE RADAR DE SEGUIMIENTO  
AUTOMATICO BEARN 8 305**

12 - 1	1 - 20b	2 - 53	4 - 189
18 - 2	1 - 22	2 - 53a	6 - 190
6 - 3	1 - 23a	2 - 54	2 - 191
6 - 5	2 - 24	4 - 59	6 - 192
8 - 8	2 - 24c	1 - 63	2 - 194c
2 - 10	1 - 27a	1 - 91	2 - 194d
16 - 12	1 - 32	1 - 92	2 - 197
1 - 13	159 - 37a	4 - 111c	4 - 221
1 - 14	154 - 37b	1 - 126	2 - 222
2 - 15	6 - 38	1 - 155	2 - 223
1 - 17	1 - 48a	1 - 187	4 - 235a
2 - 19b	1 - 48b	4 - 188	4 - 235b

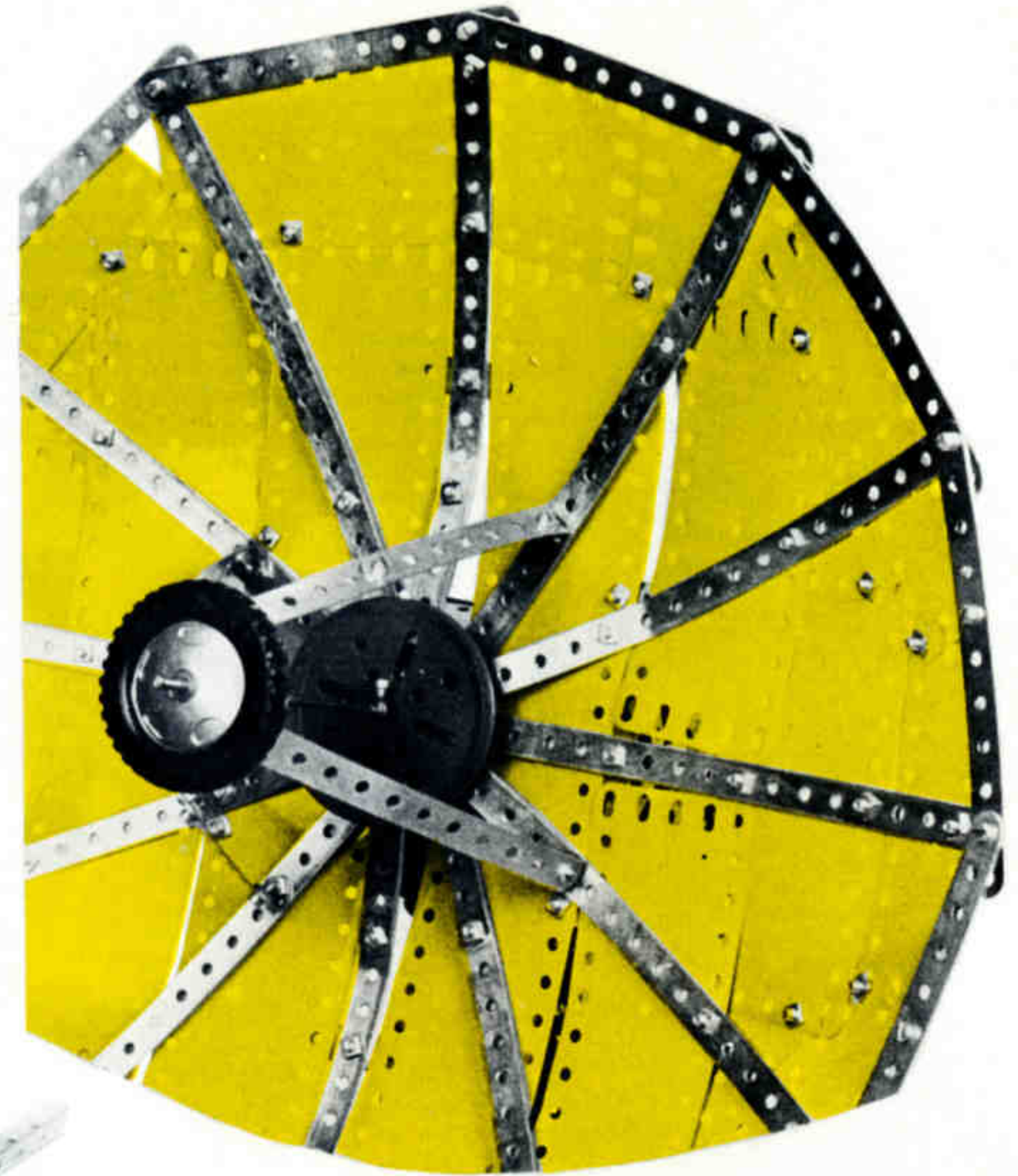
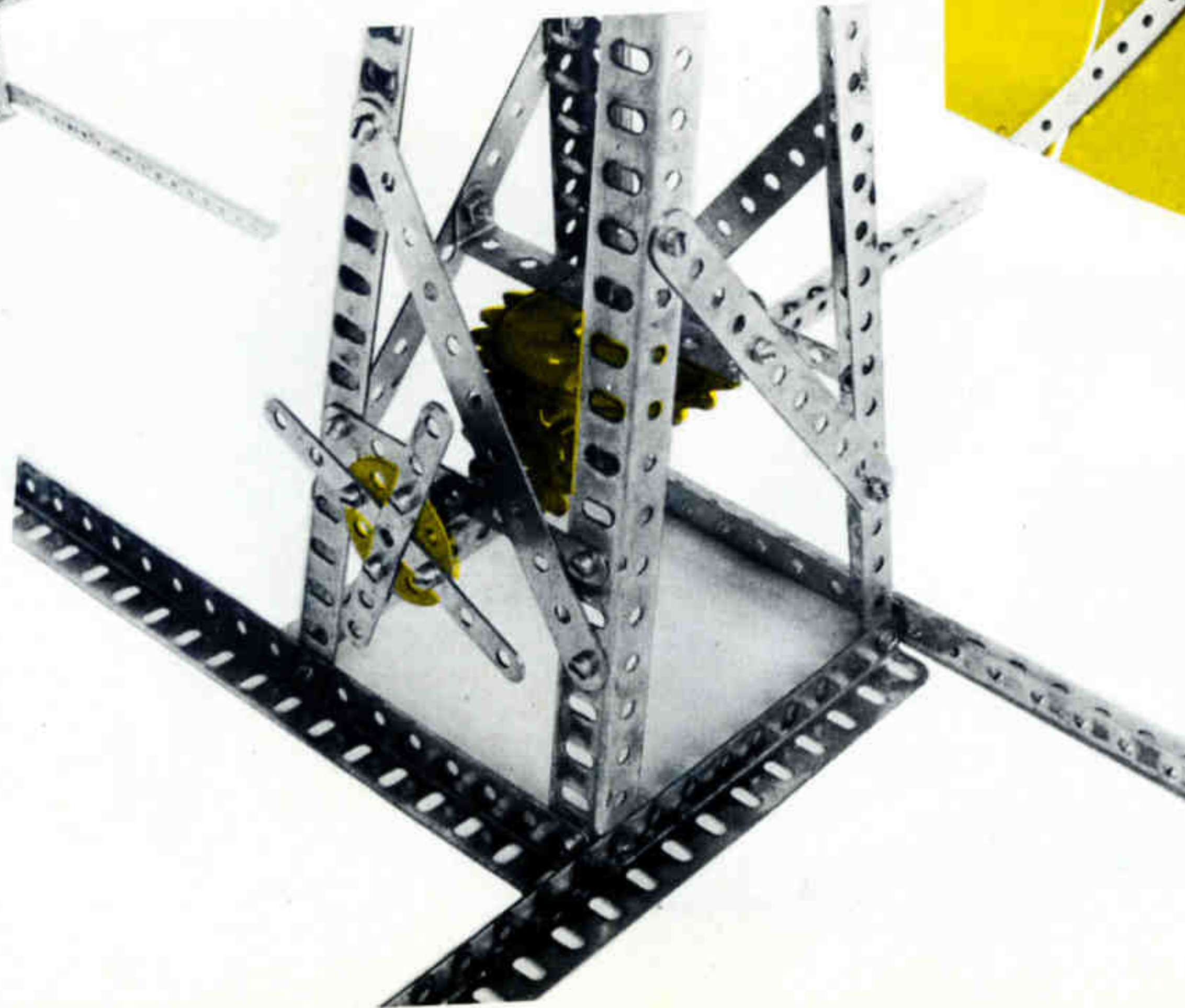

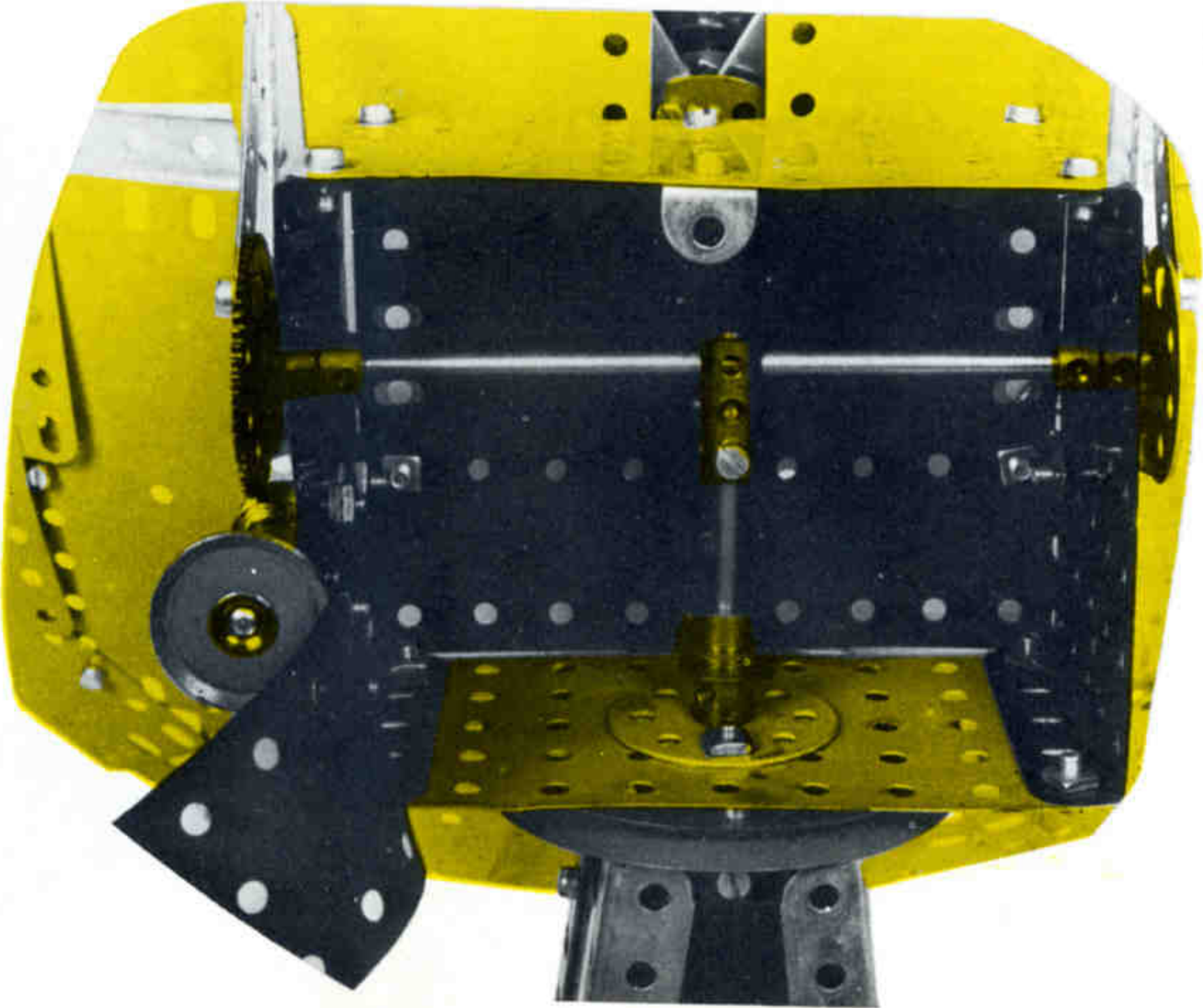
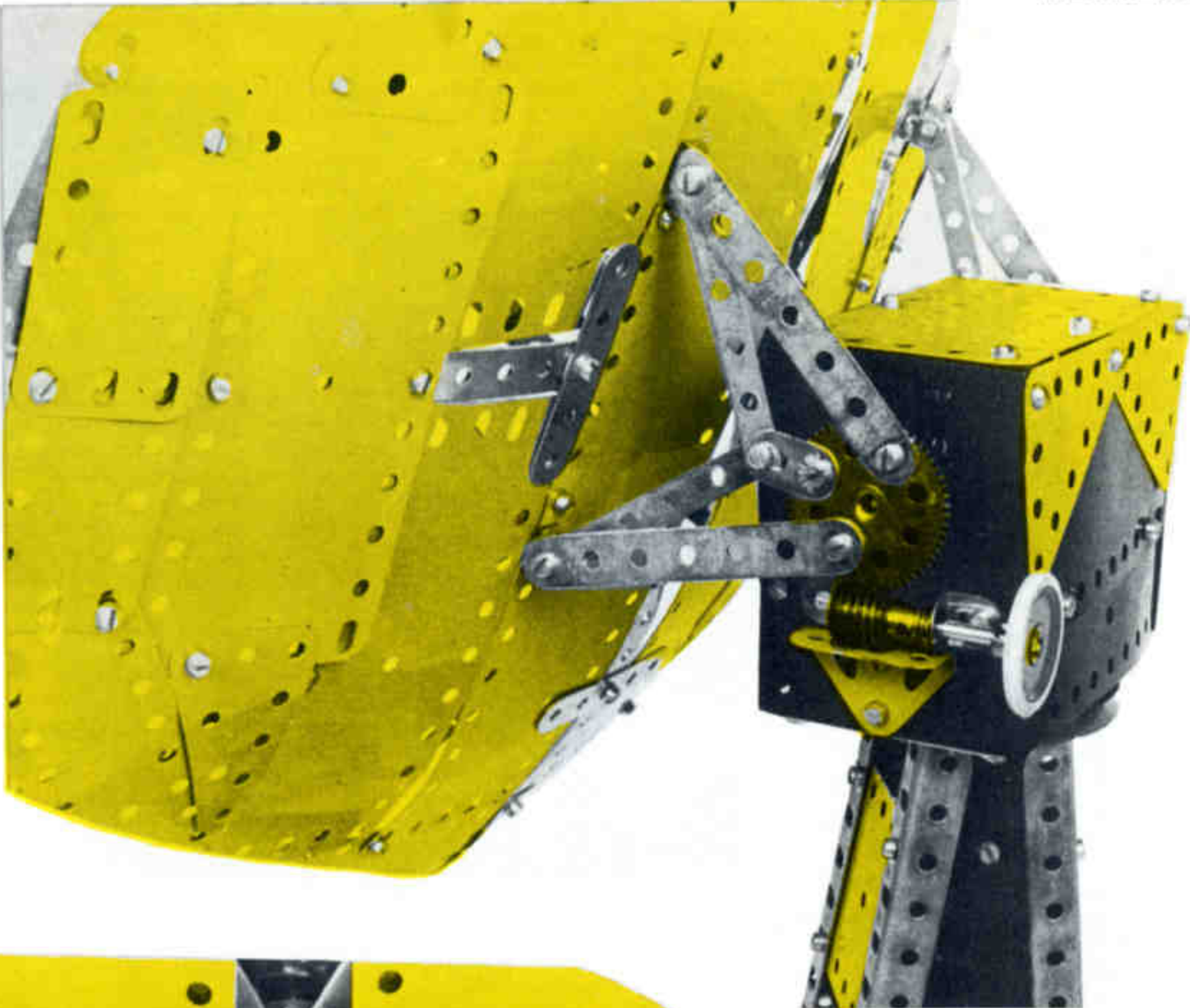
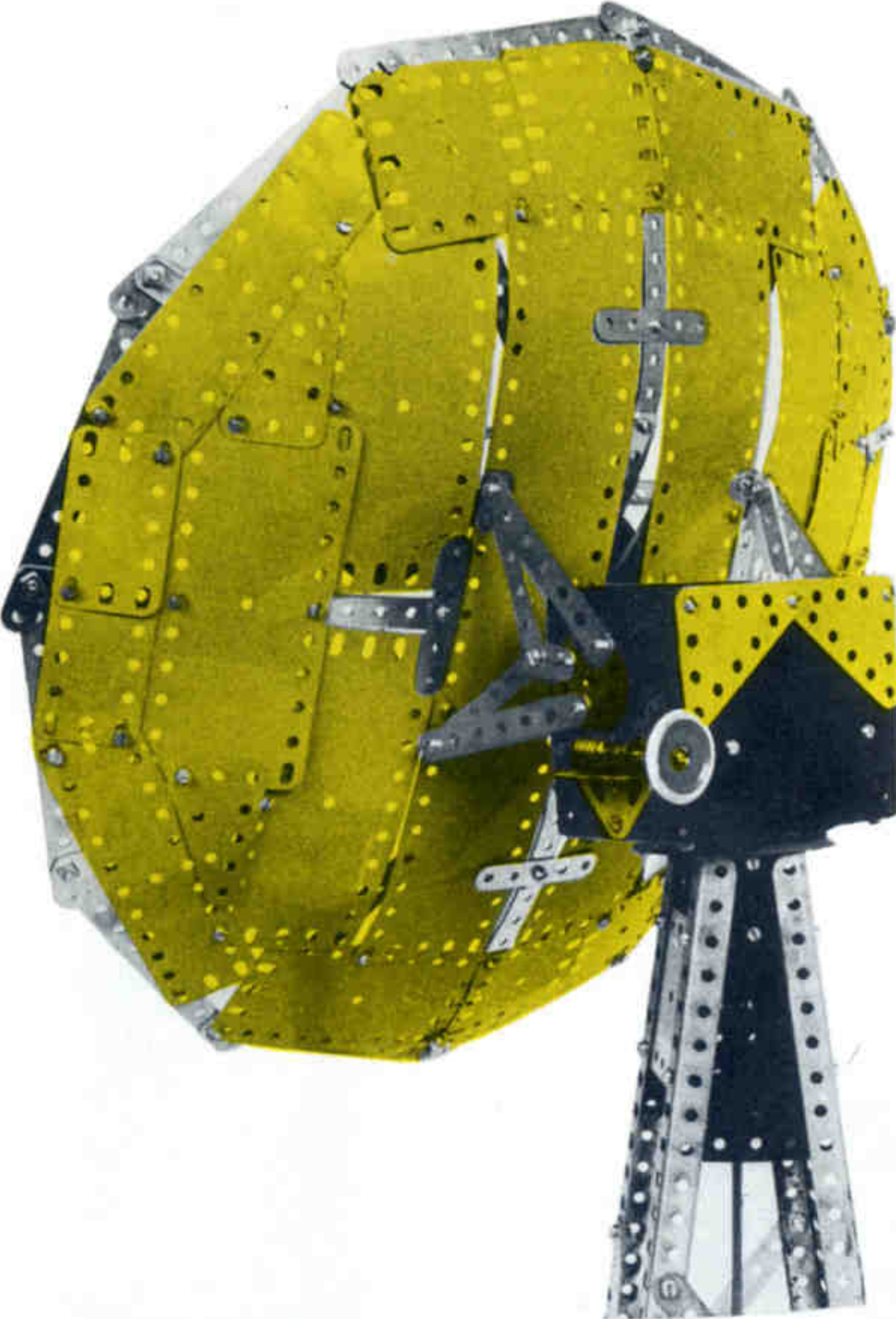

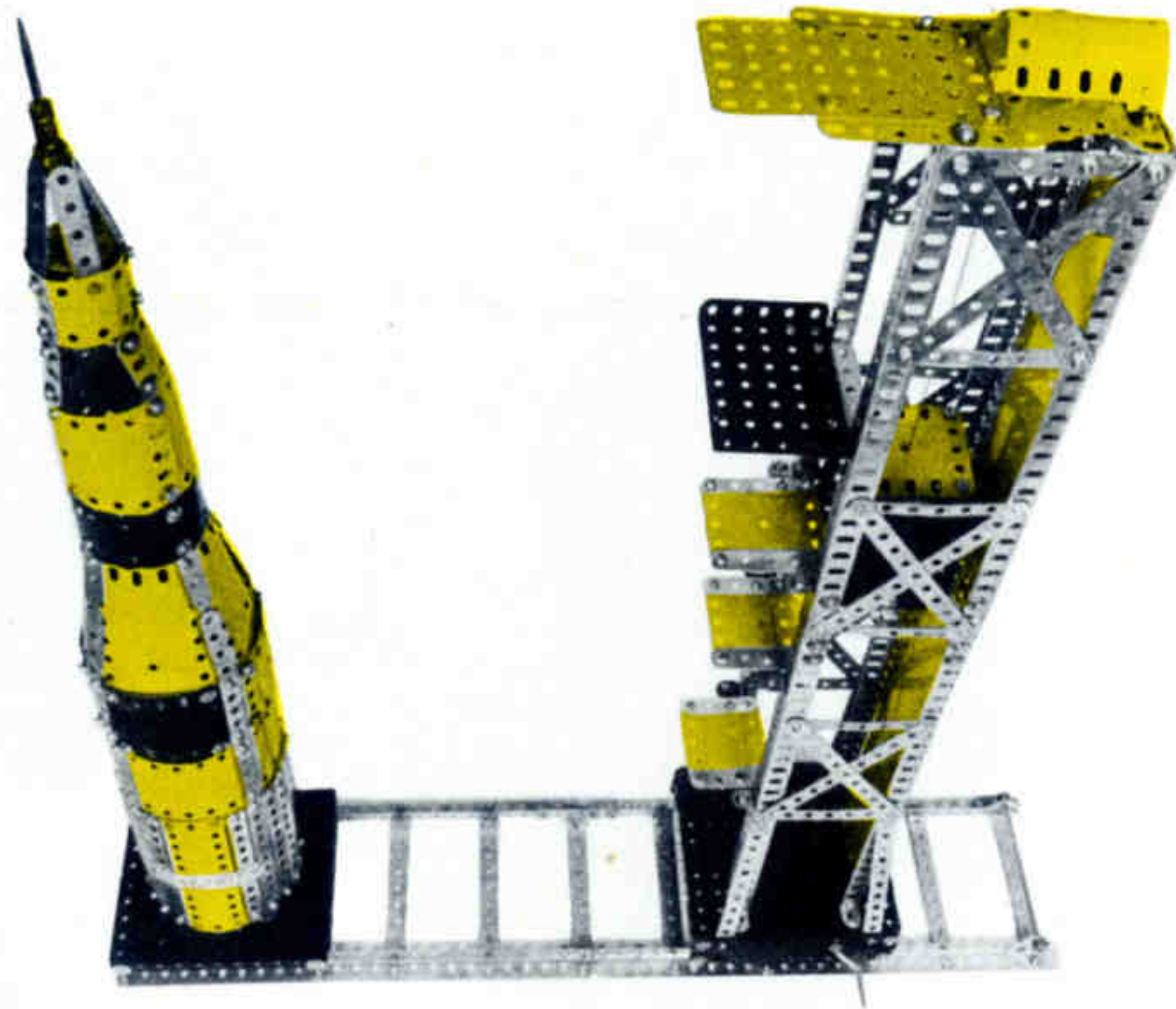

COHETE SATURNO  
CON APOLO XII  
8 / 306

8 - 1	2 - 59
18 - 2	1 - 63
5 - 3	4 - 90a
7 - 5	6 - 111c
4 - 8	4 - 125
1 - 10	2 - 126
4 - 12	5 - 188
1 - 15	4 - 189
4 - 20b	2 - 190
1 - 22	2 - 191
1 - 23	4 - 192
1 - 23a	1 - 193
1 - 24	2 - 194a
1 - 36c	3 - 194d
153 - 37a	1 - 197
152 - 37b	2 - 214
34 - 38	4 - 235b
2 - 52	

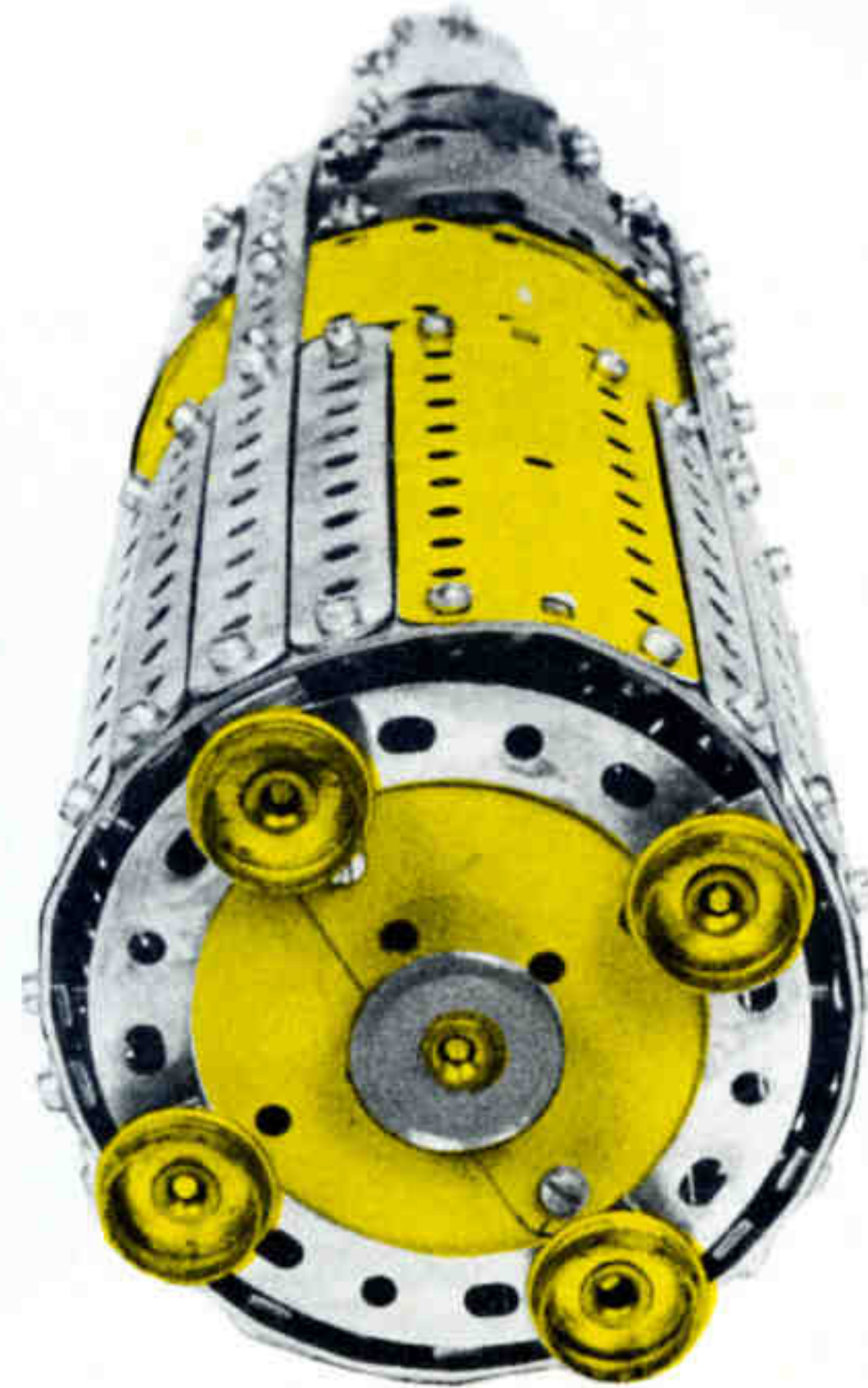



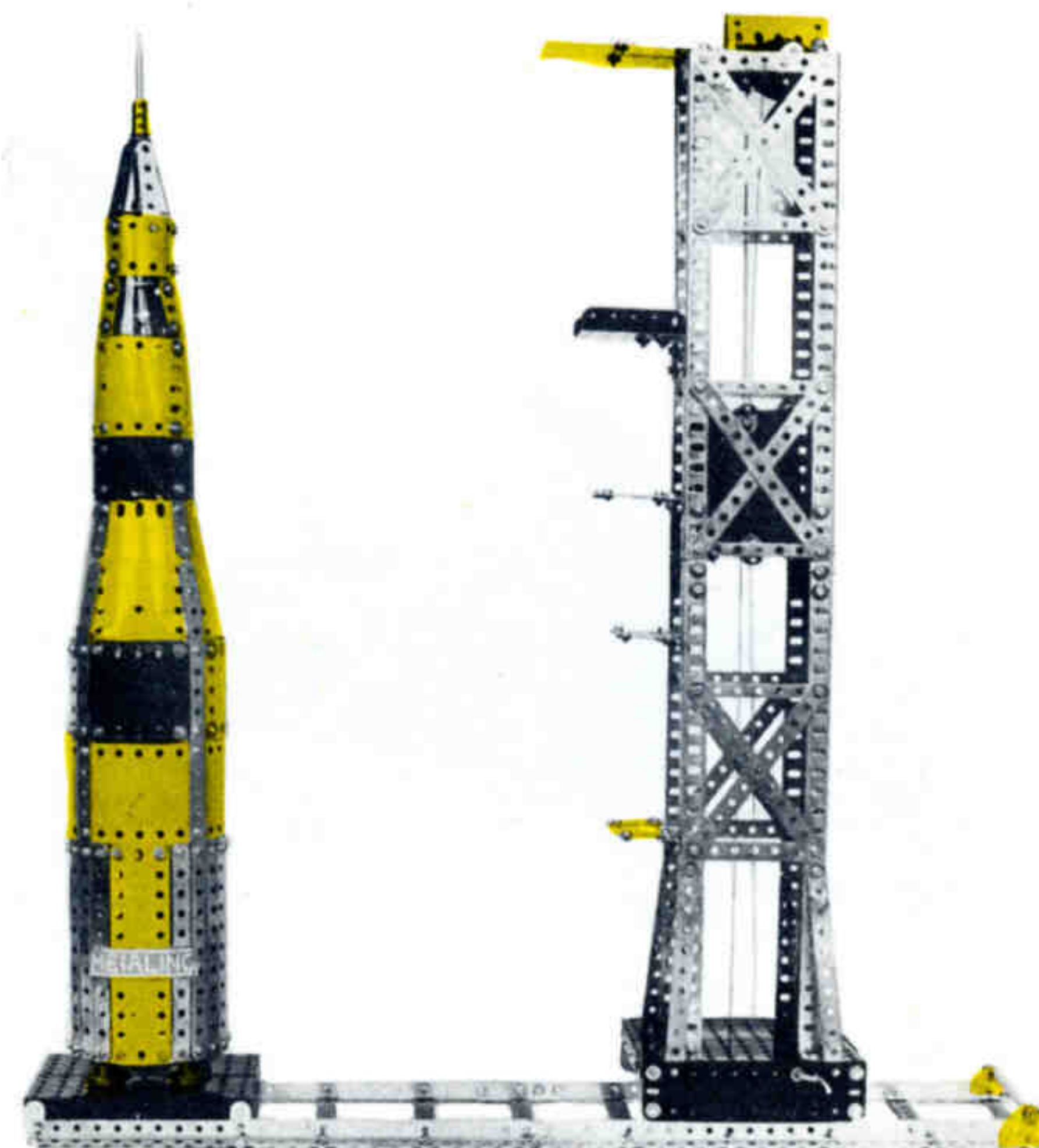

**TORRE MOVIL DE LANZAMIENTO  
DE COHETES 8/307**

4 - 1	2 - 12a	26 - 38	3 - 190
18 - 2	6 - 12c	1 - 40	2 - 194d
6 - 3	2 - 15b	2 - 48b	2 - 197
2 - 4	1 - 16	2 - 52	1 - 199
4 - 5	2 - 18a	3 - 53	1 - 213
4 - 6	1 - 19	1 - 53a	4 - 235a
4 - 6a	1 - 20a	4 - 59	4 - 235b
8 - 8	4 - 20b	1 - 63	
10 - 10	140 - 37a	5 - 188	
16 - 12	140 - 37b	2 - 189	

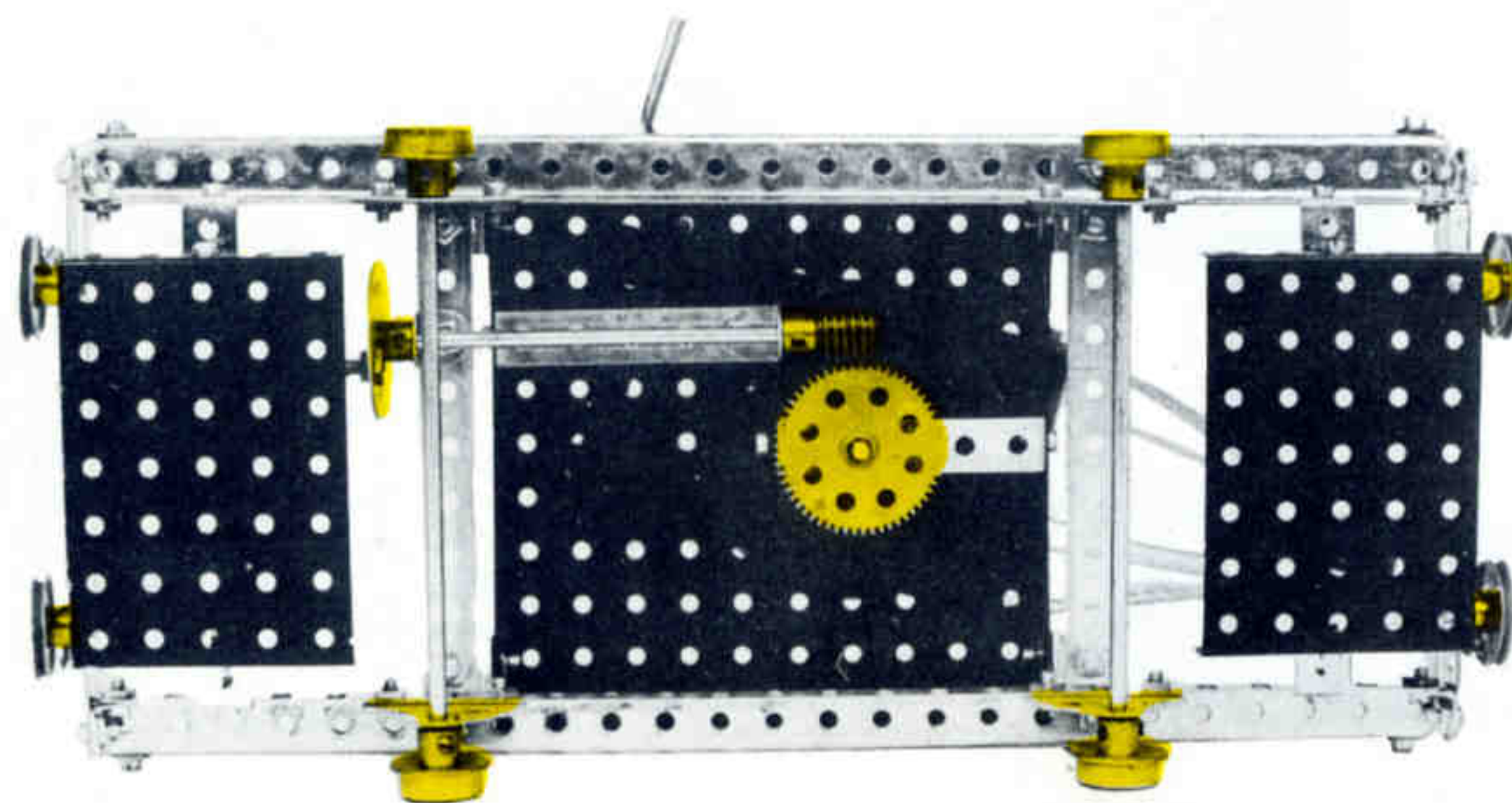
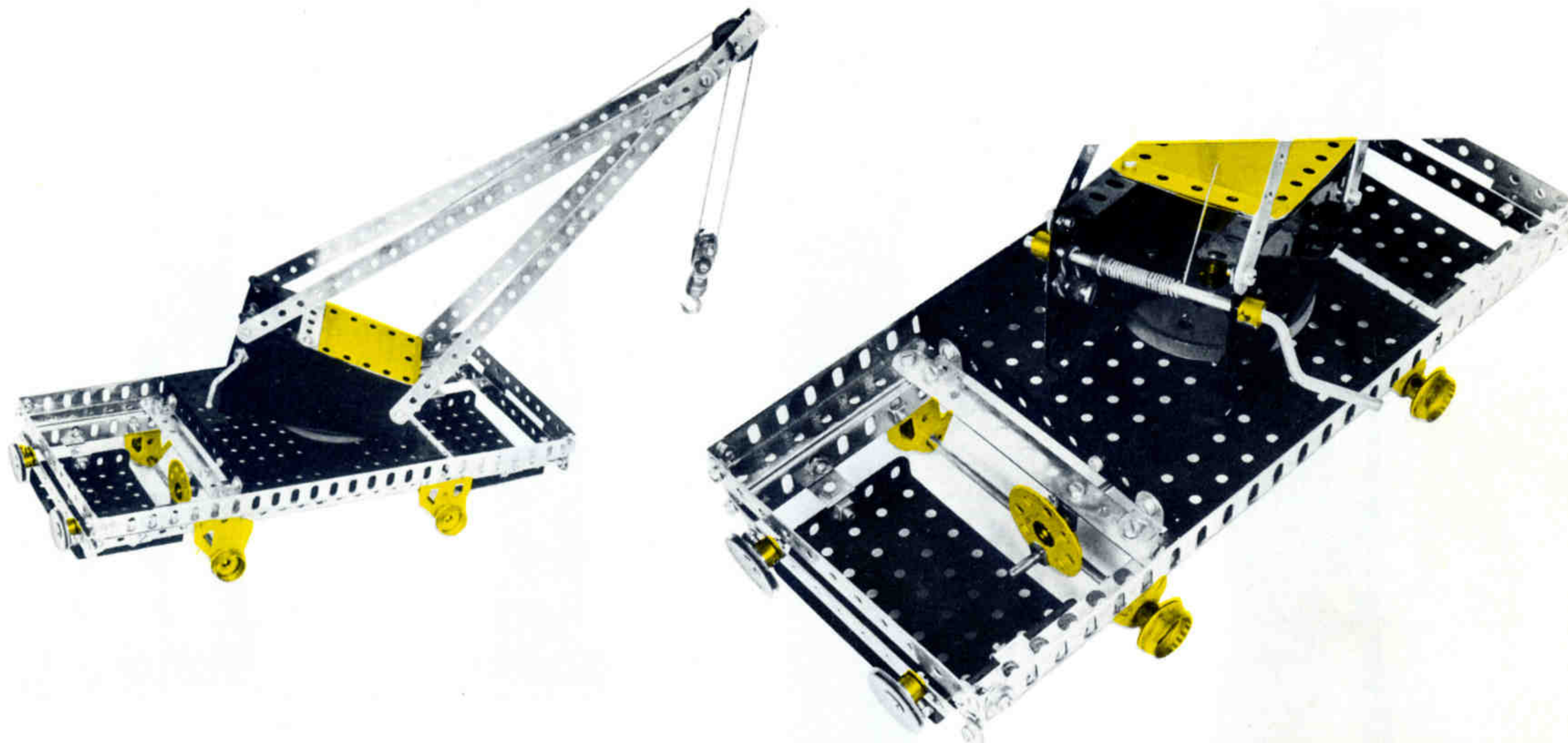

**GRUA DE FF. CC. 8 / 308**

4 - 1	1 - 19b	2 - 48a
6 - 2	4 - 20b	2 - 52
1 - 5	4 - 22	2 - 53
4 - 8	1 - 22a	2 - 54
2 - 10	1 - 23	1 - 57
1 - 11	1 - 24	4 - 59
14 - 12	1 - 27a	1 - 115
2 - 15	1 - 32	4 - 125
1 - 15a	2 - 35	4 - 126a
1 - 17	66 - 37a	1 - 147b
1 - 18a	70 - 37b	1 - 176
1 - 18b	6 - 38	1 - 186
1 - 19	1 - 40	1 - 192





Con su catálogo,  
construirás **308** modelos  
¡Tú inventarás muchos  
más!



Com o seu catálogo,  
construirás **308**  
modelos.  
Tu inventarás ainda  
muitos mais!

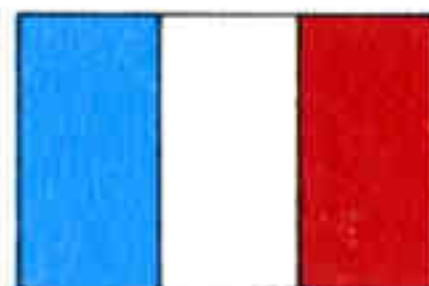

Avec son catalogue,  
tu construiras **308**  
modèles.  
Tu en inventeras bien  
d'autres encore!



With its catalogue  
you will  
make **308** models.  
You will invent  
many more  
of your own!



Con il suo catalogo  
ne costruirai **308**  
modelli,  
¡Tu ne inventerai  
molti di più!



Mit seinem Katalog  
kannst Du **308**  
Modelle erbauen;  
Du kannst noch  
viele hinzuerfinden!

MEDIO SIGLO DE EXPERIENCIA EN LA FABRICACION DE JUGUETES CONSTRUCTIVOS METALICOS

© 1970 NOVEDADES POCH, S. A. - BARCELONA - SPAIN

**Poch**